



SGS-CSTC Standards Technical Services (Shanghai) Co., Ltd.

588 West Jindu Road, Songjiang District, Shanghai, China
Telephone: +86 (0) 21 6191 5666
Fax: +86 (0) 21 6191 5678
ee.shanghai@sgs.com

Report No.: SHEM150100013102
Page: 1 of 91

1 Cover Page

RF TEST REPORT

Application No.:	SHEM1501000131CR
Applicant:	iHealth Lab Inc.
FCC ID:	SLRHS5S
Equipment Under Test (EUT):	NOTE: The following sample(s) submitted was/were identified on behalf of the client as
Product Name:	Vista
Model No.(EUT):	HS5S
Standards:	FCC PART 15 Subpart C: 2014
Date of Receipt:	January 15, 2015
Date of Test:	January 22, 2015 to January 26, 2015
Date of Issue:	February 09, 2015
Test Result:	Pass*

*In the configuration tested, the EUT detailed in this report complied with the standards specified above.



Parlam Zhan
E&E Section Manager

SGS-CSTC (Shanghai) Co., Ltd.



The manufacturer should ensure that all products in series production are in conformity with the product sample detailed in this report. If the product in this report is used in any configuration other than that detailed in the report, the manufacturer must ensure the new system complies with all relevant standards.

The report must not be used by the client to claim product certification, approval, or endorsement by NVLAP, NIST, or any agency of the federal government. All test results in this report can be traceable to National or International Standards.

This document is issued by the Company subject to its General Conditions of Service printed overleaf, available on request or accessible at www.sgs.com/terms_and_conditions.htm and, for electronic format documents, subject to Terms and Conditions for Electronic Documents at www.sgs.com/terms_e-document.htm. Attention is drawn to the limitation of liability, indemnification and jurisdiction issues defined therein. Any holder of this document is advised that information contained hereon reflects the Company's findings at the time of its intervention only and within the limits of Client's instructions, if any. The Company's sole responsibility is to its Client and this document does not exonerate parties to a transaction from exercising all their rights and obligations under the transaction documents. This document cannot be reproduced except in full, without prior written approval of the Company. Any unauthorized alteration, forgery or falsification of the content or appearance of this document is unlawful and offenders may be prosecuted to the fullest extent of the law. Unless otherwise stated the results shown in this test report refer only to the sample(s) tested and such sample(s) are retained for 90 days only.

2 Version

Revision Record				
Version	Chapter	Date	Modifier	Remark
00	/	February 09, 2015	/	Original

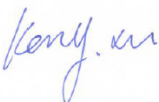
Authorized for issue by:			
Engineer		Eddy Zong _____ Print Name	 _____ Print Name
Clerk		Susie Liu _____ Print Name	 _____ Print Name
Reviewer		Kenx Xu _____ Print Name	 _____ Print Name



3 Test Summary

Test Item	FCC Requirement	Test method	Result
Antenna Requirement	FCC Part 15, Subpart C Section 15.203/15.247 (c)	---	PASS
AC Power Line Conducted Emission	FCC Part 15, Subpart C Section 15.207	ANSI C63.10 (2009) Section 6.2	N/A
Minimum 6dB Bandwidth	FCC Part 15, Subpart C Section 15.247 (a)(2)	ANSI C63.10 (2009) Section 6.9.1	PASS
Conducted Peak Output Power	FCC Part 15, Subpart C Section 15.247 (b)(3)	ANSI C63.10 (2009) Section 6.10.2	PASS
Power Spectrum Density	FCC Part 15, Subpart C Section 15.247 (e)	ANSI C63.10 (2009) Section 6.11.2	PASS
RF Conducted Spurious Emissions and Band-edge	FCC Part 15, Subpart C Section 15.247(d)	ANSI C63.10 (2009) Section 7.7.9&7.7.10	PASS
Radiated Spurious Emissions and Band-edge	FCC Part 15, Subpart C Section 15.209&15.205	ANSI C63.10 (2009) Section 6.5&6.6&6.7	PASS

N/A: Not applicable, please refer to Section 7.3 of this report for details.

4 Contents

	Page
1 COVER PAGE	1
2 VERSION	2
3 TEST SUMMARY	3
4 CONTENTS.....	4
5 GENERAL INFORMATION	5
5.1 CLIENT INFORMATION.....	5
5.2 GENERAL DESCRIPTION OF E.U.T.....	5
5.3 TECHNICAL SPECIFICATIONS.....	5
5.4 TEST MODE.....	5
5.5 DESCRIPTION OF SUPPORT UNITS.....	6
5.6 TEST CHANNEL	6
5.7 TEST LOCATION	7
5.8 TEST FACILITY	7
5.9 DEVIATION FROM STANDARDS.....	7
5.10 MEASUREMENT UNCERTAINTY	8
6 EQUIPMENTS USED DURING TEST.....	9
7 TEST RESULTS	10
7.1 E.U.T. TEST CONDITIONS	10
7.2 ANTENNA REQUIREMENT.....	11
7.3 CONDUCTED EMISSIONS ON MAINS TERMINALS	12
7.4 6dB OCCUPIED BANDWIDTH.....	14
7.5 CONDUCTED PEAK OUTPUT POWER	22
7.6 PEAK POWER SPECTRAL DENSITY.....	28
7.7 CONDUCTED SPURIOUS EMISSIONS AND BAND-EDGE	42
7.7.1 <i>Conducted spurious emission</i>	43
7.7.2 <i>Conducted Band-edge</i>	55
7.8 RADIATED SPURIOUS EMISSIONS AND BAND-EDGE.....	59
7.8.1 <i>Radiated Spurious Emissions</i>	62
7.8.2 <i>Radiated Band edge</i>	69
7.9 99% OCCUPIED BANDWIDTH	84
8 TEST SETUP PHOTOGRAPHS.....	91
9 EUT CONSTRUCTIONAL DETAILS.....	91

5 General Information

5.1 Client Information

Applicant: iHealth
 Address of Applicant: 719 N.Shoreline Blvd, Mountain View, CA94043
 Manufacturer: Andon Health Co. Ltd
 Address of Manufacturer: No. 3 JinPing Street YaAn Road Nankai District Tianjin, China
 Factory: Andon Health Co. Ltd
 Address of Factory: No. 3 JinPing Street YaAn Road Nankai District Tianjin, China

5.2 General Description of E.U.T.

Brand Name: iHealth
 Product Description: Mobile Product with WiFifunction
 Power Supply: DC 6V 4*AA Batteries Size

5.3 Technical Specifications

Operation Frequency: 802.11b/g/n20: 2412MHz~2462MHz
 802.11n40: 2422MHz~2452MHz
 Modulation Technique: 802.11 b DSSS(CCK, DQPSK, DBPSK)
 802.11 g/n20/n40 OFDM(64QAM, 16QAM, QPSK, BPSK)
 Data Rate: 802.11b: 1/2/5.5/11Mbps,
 802.11g: 6/9/12/18/24/36/48/54Mbps
 802.11 n20/n40: MCS0 - MCS7
 Number of Channel: 11 Channels (802.11b,g,n20)
 7 Channels (802.11 n40)
 Antenna Type: PIFA
 Antenna Gain: 0dBi

5.4 Test Mode

Test Mode	Description of Test Mode
Engineering mode	Using test software to control EUT working in continuous transmitting and select channel and modulation type.

5.5 Description of Support Units

The EUT has been tested with support equipments as below.

Description	Manufacturer	Model No.	Supplied By
Laptop	Lenovo	ThinkPad X 100e	SGS

Software name	Manufacturer	Version	Supplied By
sscom3.2	/	/	Client

Description of connection

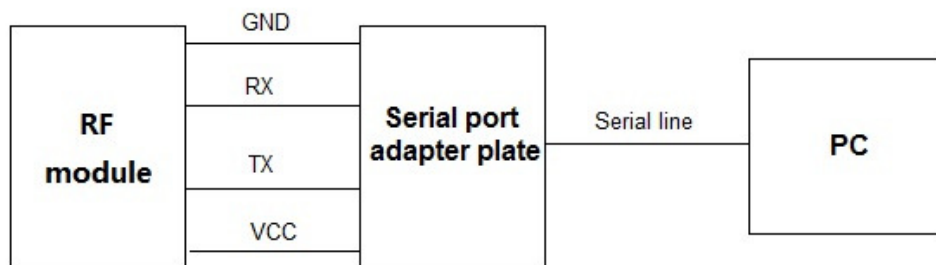

5.6 Test Channel

Preliminary tests were performed in all tests in different data rate and antenna configurations at Lowest channel, the data rates of worse case as below were chosen for final test.

Modulation Type	Channel	Frequency	Data rate
802.11 b	The Lowest channel(CH1)	2412MHz	1Mbps
	The middle channel(CH6)	2437MHz	1Mbps
	The Highest channel(CH11)	2462MHz	1Mbps
802.11 g	The Lowest channel(CH1)	2412MHz	6Mbps
	The middle channel(CH6)	2437MHz	6Mbps
	The Highest channel(CH11)	2462MHz	6Mbps
802.11 n20	The Lowest channel(CH1)	2412MHz	MCS0
	The middle channel(CH6)	2437MHz	MCS0
	The Highest channel(CH11)	2462MHz	MCS0
802.11 n40	The Lowest channel(CH1)	2422MHz	MCS0
	The middle channel(CH4)	2437MHz	MCS0
	The Highest channel(CH7)	2452MHz	MCS0

5.7 Test Location

All tests were performed at:

SGS-CSTC Standards Technical Services (Shanghai) Co., Ltd.
No.588 West Jindu Road, Songjiang District, Shanghai, China.201612.
Tel: +86 21 6191 5666
Fax: +86 21 6191 5678

5.8 Test Facility

The test facility is recognized, certified, or accredited by the following organizations:

- **CNAS (No. CNAS L0599)**

CNAS has accredited SGS-CSTC Standards Technical Services (Shanghai) Co., Ltd. to ISO/IEC 17025:2005 General Requirements for the Competence of Testing and Calibration Laboratories (CNAS-CL01 Accreditation Criteria for the Competence of Testing and Calibration Laboratories) for the competence in the field of testing. Date of expiry: 2017-07-14.

- **FCC – Registration No.: 402683**

SGS-CSTC Standards Technical Services (Shanghai) Co., Ltd. has been registered and fully described in a report filed with the Federal Communications Commission (FCC). The acceptance letter from the FCC is maintained in our files. Registration No.: 402683, Expiry Date: 2017-09-16.

- **Industry Canada (IC) – IC Assigned Code: 8617A**

The 3m Semi-anechoic chamber of SGS-CSTC Standards Technical Services (Shanghai) Co., Ltd. has been registered by Certification and Engineering Bureau of Industry Canada for radio equipment testing with Registration No.: 8617A-1. Expiry Date: 2017-06-18.

- **VCCI (Member No.: 3061)**

The 3m Semi-anechoic chamber and Shielded Room of SGS-CSTC Standards Technical Services (Shanghai) Co., Ltd. has been registered in accordance with the Regulations for Voluntary Control Measures with Registration No.: R-3868 ,C-4336,T-2221,G-830 respectively. Date of Expiry: 2017-11-16.

5.9 Deviation from Standards

For Radiated Spurious Emissions test, we use the test setup reference ANSI C63.10:2013 with EUT height 1.5m for emission above 1GHz.

5.10 Measurement Uncertainty

No.	Parameter	Measurement Uncertainty
1	Radio Frequency	$< \pm 1 \times 10^{-5}$
2	Total RF power, conducted	$< \pm 1.5$ dB
3	RF power density, conducted	$< \pm 3$ dB
4	Spurious emissions, conducted	$< \pm 3$ dB
5	All emissions, radiated	$< \pm 6$ dB (30MHz – 1GHz) $< \pm 6$ dB (above 1GHz)
6	Temperature	$< \pm 1^{\circ}\text{C}$
7	Humidity	$< \pm 5$ %
8	DC and low frequency voltages	$< \pm 3$ %

6 Equipments Used during Test

Item	Test Equipment	Manufacturer	Model No.	Serial No.	Cal. Date	Cal. Due date
1	EMI test receiver	Rohde & Schwarz	ESCS30	100086	2014-02-13	2015-02-12
2	Line impedance stabilization network	SCHWARZBECK	NSLK8127	8127490	2014-02-13	2015-02-12
3	Line impedance stabilization network	ETS	3816/2	00034161	2014-02-13	2015-02-12
4	Spectrum Analyzer	Rohde & Schwarz	FSP-30	2705121009	2014-02-13	2015-02-12
5	EMI test receiver	Rohde & Schwarz	ESU40	100109	2014-02-13	2015-02-12
6	Active Loop Antenna (9kHz to 30MHz)	Rohde & Schwarz	FMZB 1519	1519-034	2014-03-19	2015-03-18
7	Broadband UHF-VHF ANTENNA (25MHz to 2GHz)	SCHWARZBECK	VULB9168	9168-313	2014-02-13	2015-02-12
8	Ultra broadband antenna (25MHz to 3GHz)	Rohde & Schwarz	HL562	100227	2014-08-30	2015-08-29
9	Horn Antenna (1GHz to 18GHz)	Rohde & Schwarz	HF906	100284	2014-02-13	2015-02-12
10	Horn Antenna (1GHz to 18GHz)	SCHWARZBECK	BBHA9120D	9120D-679	2014-02-13	2015-02-12
11	Horn Antenna (14GHz to 40GHz)	SCHWARZBECK	BBHA 9170	BBHA9170373	2014-02-13	2015-02-12
12	Pre-amplifier (9KHz – 2GHz)	LNA6900	TESEQ	71033	2014-02-13	2015-02-12
13	Pre-amplifier (1GHz – 26.5GHz)	Rohde & Schwarz	SCU-F0118-G40-BZ4-CSS(F)	10001	2014-02-13	2015-02-12
14	Pre-amplifier (14GHz – 40GHz)	Rohde & Schwarz	SCU-F1840-G35-BZ3-CSS(F)	10001	2014-02-13	2015-02-12
15	Tunable Notch Filter	Wainwright instruments GmbH	WRCT800.0/880.0-0.2/40-5SSK	9170397	2014-06-02	2015-06-01
16	High pass Filter	FSCW	HP 12/2800-5AA2	19A45-02	2014-06-02	2015-06-01
17	High-low temperature cabinet	Suzhou Zhihe	TL-40	50110050	2014-09-11	2015-09-10
18	AC power stabilizer	WOCEN	6100	51122	2014-06-02	2015-06-01
19	DC power	QJE	QJ30003SII	611145	2014-06-02	2015-06-01
20	Signal Generator (Interferer)	Agilent	SMR40	100555	2014-02-14	2015-02-13
21	Signal Generator (Blocker)	Rohde & Schwarz	SMJ100A	02.20.360.142	2014-02-13	2015-02-12
22	Splitter	Anritsu	MA1612A	M12265	/	/
23	Coupler	e-meca	803-S-1	900-M01	/	/

7 Test Results

7.1 E.U.T. test conditions

Test Power: DC 6V

Requirements: 15.31(e) For intentional radiators, measurements of the variation of the input power or the radiated signal level of the fundamental frequency component of the emission, as appropriate, shall be performed with the supply voltage varied between 85% and 115% of the nominal rated supply voltage. For battery operated equipment, the equipment tests shall be performed using a new battery.

Operating Environment:

Temperature:	20.0 -25.0 °C
Humidity:	35-75 % RH
Atmospheric Pressure:	99.2 -102.0 kPa

Test frequencies: According to the 15.31(m) Measurements on intentional radiators or receivers, other than TV broadcast receivers, shall be performed and, if required, reported for each band in which the device can be operated with the device operating at the number of frequencies in each band specified in the following table:

Frequency range over which device operates	Number of frequencies	Location in the range of operation
1 MHz or less	1	Middle
1 to 10 MHz	2	1 near top and 1 near bottom
More than 10 MHz	3	1 near top, 1 near middle and 1 near bottom

Pursuant to Part 15.31(c) For swept frequency equipment, measurements shall be made with the frequency sweep stopped at those frequencies chosen for the measurements to be reported.

7.2 Antenna Requirement

Standard requirement:

15.203 requirement:

An intentional radiator shall be designed to ensure that no antenna other than that furnished by the responsible party shall be used with the device. The use of a permanently attached antenna or of an antenna that uses a unique coupling to the intentional radiator, the manufacturer may design the unit so that a broken antenna can be replaced by the user, but the use of a standard antenna jack or electrical connector is prohibited

15.247(b) (4) requirement:

The conducted output power limit specified in paragraph (b) of this section is based on the use of antennas with directional gains that do not exceed 6 dBi. Except as shown in paragraph (c) of this section, if transmitting antennas of directional gain greater than 6 dBi are used, the conducted output power from the intentional radiator shall be reduced below the stated values in paragraphs (b)(1), (b)(2), and (b)(3) of this section, as appropriate, by the amount in dB that the directional gain of the antenna exceeds 6 dBi.

EUT Antenna:

The antenna is PCB antenna. The gain of the antenna is less than 0 dBi.

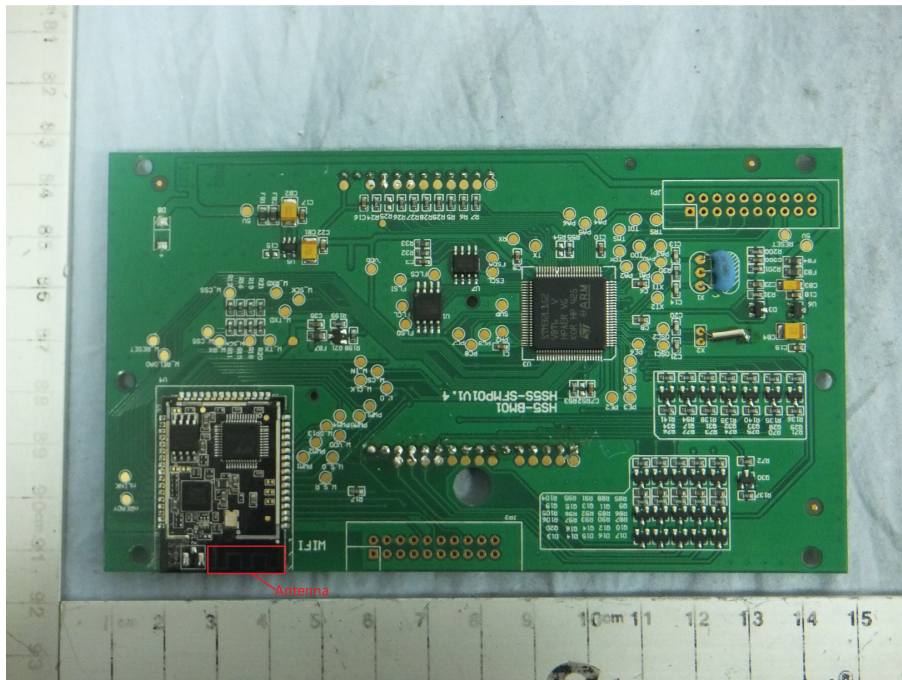

7.3 Conducted Emissions on Mains Terminals

Frequency Range: 150 KHz to 30 MHz

Class/Severity: Class B

Limit:

Frequency range MHz	Class B Limits: dB (µV)	
	Quasi-peak	Average
0.15 to 0.50	66 to 56	56 to 46
0.50 to 5	56	46
5 to 30	60	50

Note1: The limit decreases linearly with the logarithm of the frequency in the range 0.15 MHz to 0.50MHz.

Note2: The lower limit is applicable at the transition frequency.

Test site/setup:

Test instrumentation set-up:

Frequency Range	Detector	RBW	VBW
9KHz to 150Hz	Quasi-peak	200Hz	500Hz
150KHz to 30MHz	Quasi-peak	9kHz	30kHz

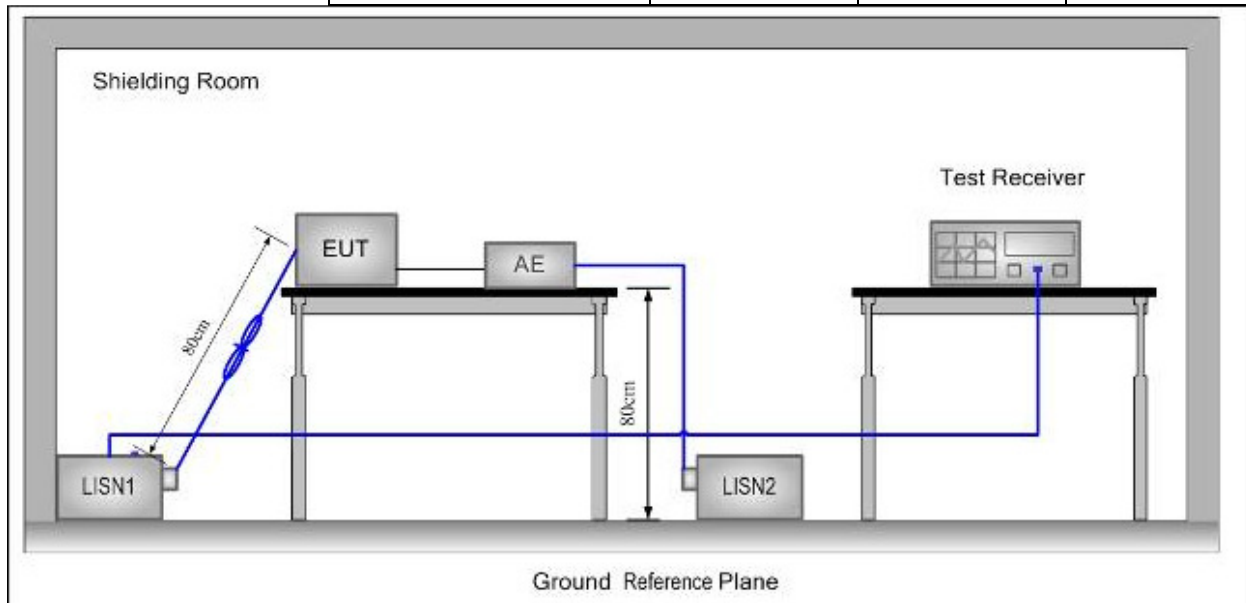

Test Procedure:

1. The mains terminal disturbance voltage was measured with the EUT in a shielded room.
2. The EUT was connected to AC power source through a LISN 1 (Line Impedance Stabilization Network) which provides 50Ω/50µH + 5Ω linear impedance. The power cables of all other units of the EUT were connected to a second LISN, which was bonded to the ground reference plane in the same way as the LISN for the unit being measured. A multiple socket outlet strip was used to connect multiple power cables to a single LISN provided the rating of the LISN was not exceeded
3. The tabletop EUT was placed upon a non-metallic table 0.8m above the ground reference plane.

And for floor-standing arrangement, the EUT was placed on the horizontal ground reference plane, but separated from metallic contact with the ground reference plane by 0.1m of insulation.

4. The test was performed with a vertical ground reference plane. The rear of the EUT shall be 0.4 m from the vertical ground reference plane. The vertical ground reference plane was bonded to the horizontal ground reference plane. The LISN was placed 0.8 m from the boundary of the unit under test and bonded to a ground reference plane for LISN mounted on top of the ground reference plane. This distance was between the closest points of the LISN and the EUT. The mains lead of EUT excess 0.8m was folded back and forth parallel to the lead so as to form a horizontal bundle with a length between 0.3m and 0.4m. All other units of the EUT and associated equipment were at least 0.8 m from the LISN.

Remark: Pre-scan was performed with peak detected on all ports, Quasi-peak & average measurements were performed at the frequencies at which maximum peak emission level were detected. Pretest under all modes; choose the worst case mode (802.11b in Middle channel) record on the report. Please see the attached Quasi-peak and Average test results.

Test Result: N/A

Test Data:

This EUT is powered by battery only; therefore the AC Conducted Emission test is not applicable.

7.4 6dB Occupied Bandwidth

Test Configuration:

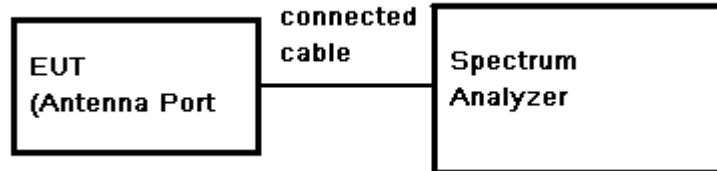

Test Procedure:

1. Place the EUT on the table and set it in transmitting mode.
2. Remove the antenna from the EUT and then connect a low loss RF cable from the antenna port to the spectrum analyzer.
3. Set the spectrum analyzer as RBW=300KHz, VBW \geq 3* RBW, Span=30/50MHz, Sweep=auto
4. Mark the peak frequency and -6dB (upper and lower) frequency.
5. Repeat above procedures until all frequency measured was complete.

Limit: \geq 500 kHz

Test Result: Pass

Test Data:

Test mode: 802.11b

CH	Frequency (MHz)	Bandwidth (MHz)	Limit Bandwidth (KHz)	Result
Low	2412	10.20	500	PASS
Mid	2437	10.08	500	PASS
High	2462	10.14	500	PASS

Test mode: 802.11g

CH	Frequency (MHz)	Bandwidth (MHz)	Limit Bandwidth (KHz)	Result
Low	2412	16.50	500	PASS
Mid	2437	16.56	500	PASS
High	2462	16.50	500	PASS

Test mode: 802.11n20

CH	Frequency (MHz)	Bandwidth (MHz)	Limit Bandwidth (KHz)	Result
Low	2412	17.58	500	PASS
Mid	2437	17.64	500	PASS
High	2462	17.58	500	PASS

Test mode: 802.11n40

CH	Frequency (MHz)	Bandwidth (MHz)	Limit Bandwidth (KHz)	Result
Low	2422	35.68	500	PASS
Mid	2437	36.00	500	PASS
High	2452	36.16	500	PASS

Test plot as follows:

Test mode:	802.11b	Channel:	Lowest
-------------------	----------------	-----------------	---------------

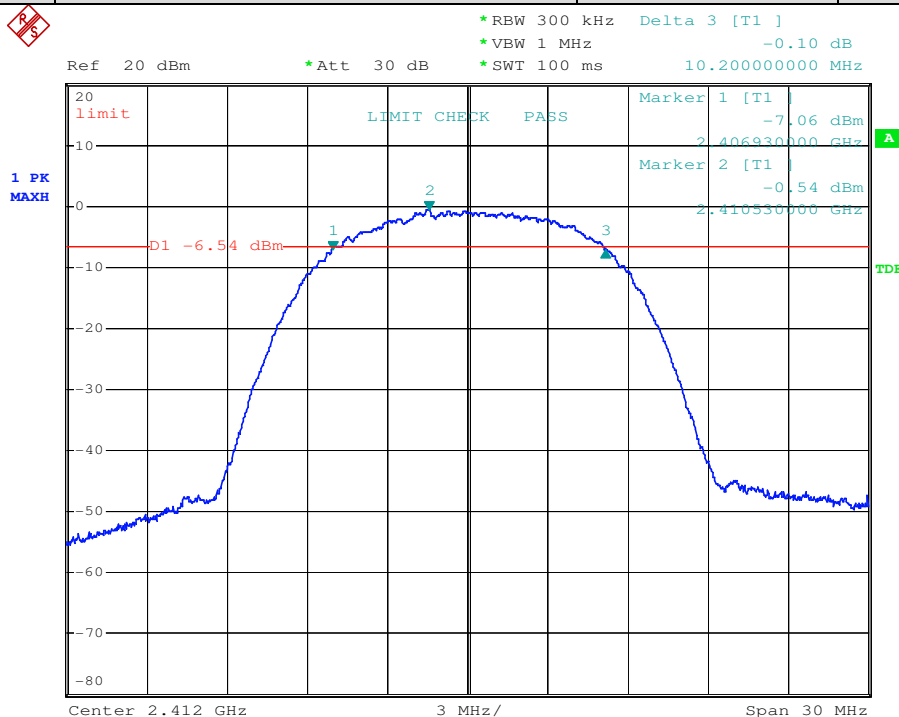

Test mode:	802.11b	Channel:	Middle
-------------------	----------------	-----------------	---------------

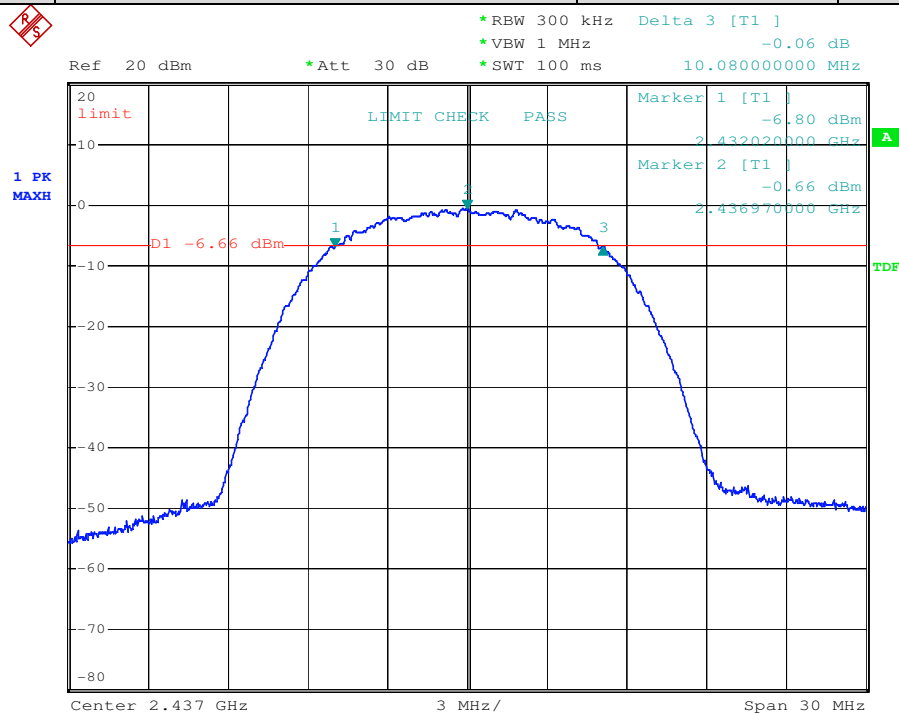



Test mode:	802.11b	Channel:	Highest
-------------------	----------------	-----------------	----------------

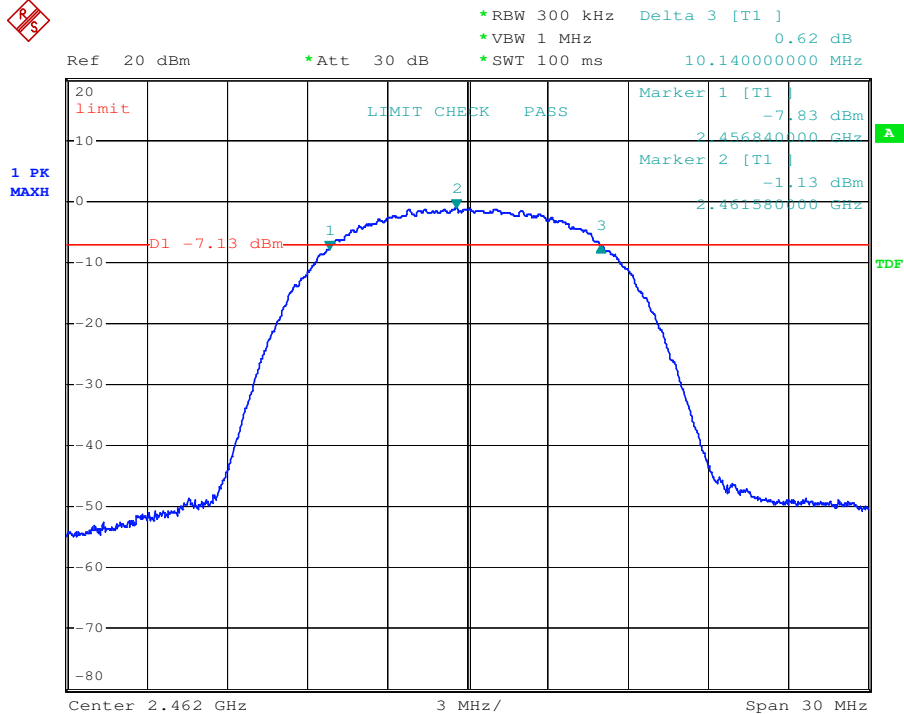

Test mode:	802.11g	Channel:	Lowest
-------------------	----------------	-----------------	---------------

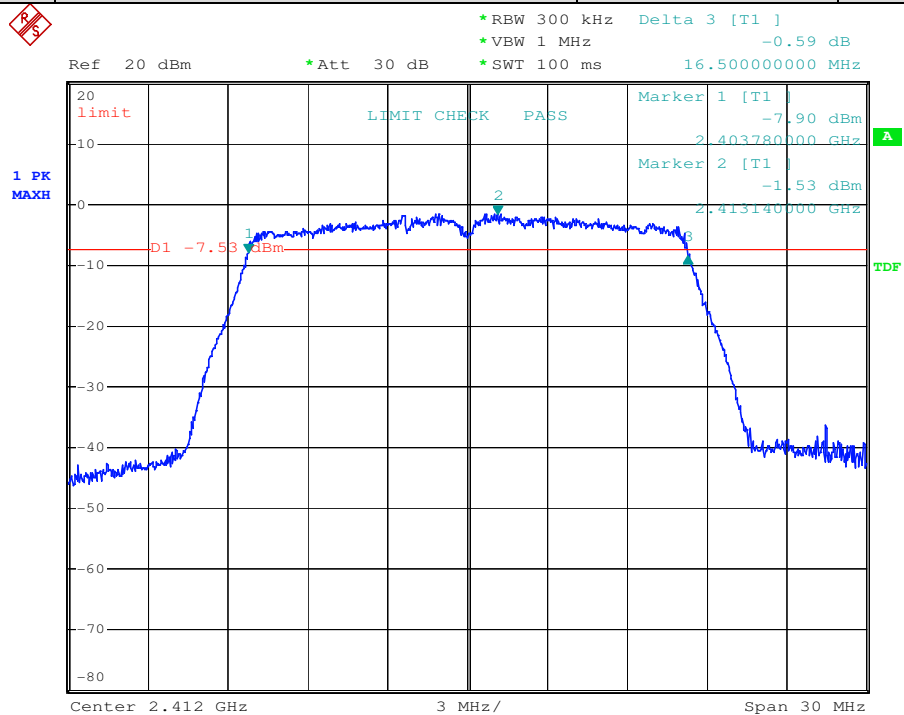

This document is issued by the Company subject to its General Conditions of Service printed overleaf, available on request or accessible at www.sgs.com/terms_and_conditions.htm and, for electronic format documents, subject to Terms and Conditions for Electronic Documents at www.sgs.com/terms_e-document.htm. Attention is drawn to the limitation of liability, indemnification and jurisdiction issues defined therein. Any holder of this document is advised that information contained hereon reflects the Company's findings at the time of its intervention only and within the limits of Client's instructions, if any. The Company's sole responsibility is to its Client and this document does not exonerate parties to a transaction from exercising all their rights and obligations under the transaction documents. This document cannot be reproduced except in full, without prior written approval of the Company. Any unauthorized alteration, forgery or falsification of the content or appearance of this document is unlawful and offenders may be prosecuted to the fullest extent of the law. Unless otherwise stated the results shown in this test report refer only to the sample(s) tested and such sample(s) are retained for 90 days only



Test mode:	802.11g	Channel:	Middle
-------------------	----------------	-----------------	---------------

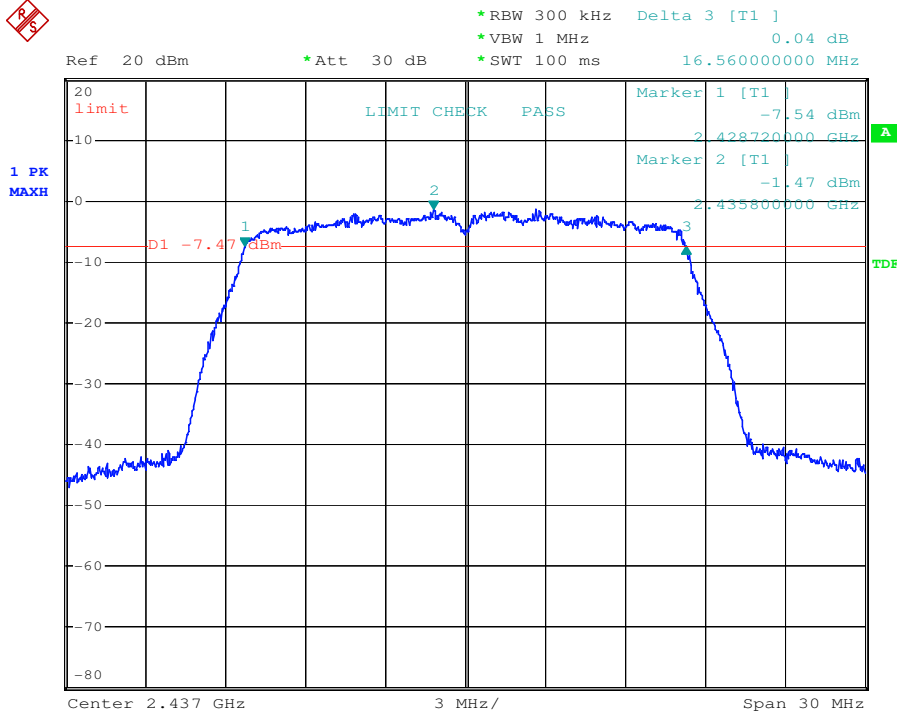

Test mode:	802.11g	Channel:	Highest
-------------------	----------------	-----------------	----------------

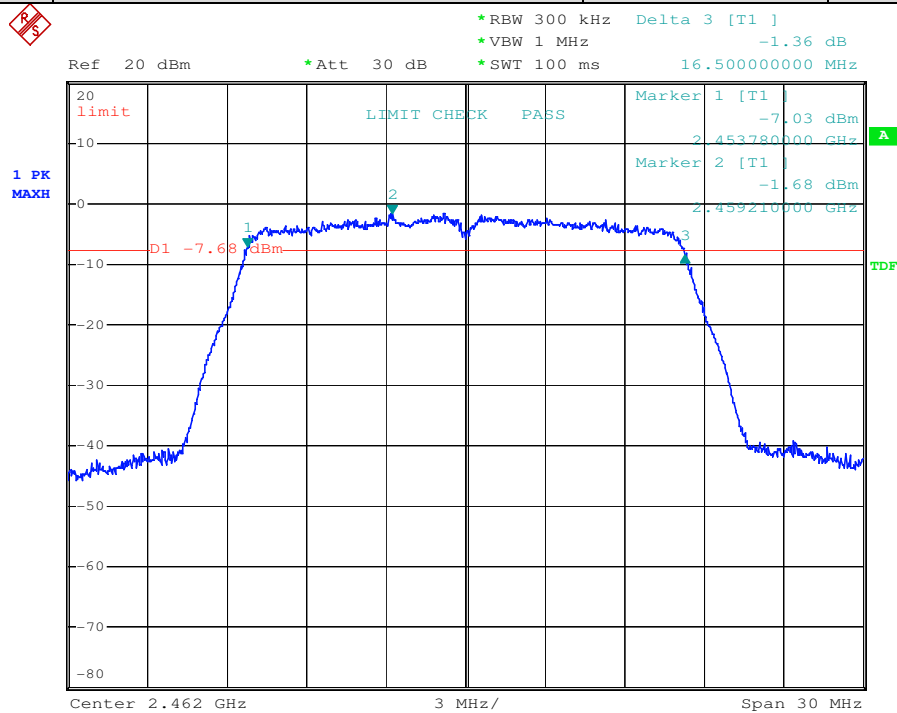

This document is issued by the Company subject to its General Conditions of Service printed overleaf, available on request or accessible at www.sgs.com/terms_and_conditions.htm and, for electronic format documents, subject to Terms and Conditions for Electronic Documents at www.sgs.com/terms_e-document.htm. Attention is drawn to the limitation of liability, indemnification and jurisdiction issues defined therein. Any holder of this document is advised that information contained hereon reflects the Company's findings at the time of its intervention only and within the limits of Client's instructions, if any. The Company's sole responsibility is to its Client and this document does not exonerate parties to a transaction from exercising all their rights and obligations under the transaction documents. This document cannot be reproduced except in full, without prior written approval of the Company. Any unauthorized alteration, forgery or falsification of the content or appearance of this document is unlawful and offenders may be prosecuted to the fullest extent of the law. Unless otherwise stated the results shown in this test report refer only to the sample(s) tested and such sample(s) are retained for 90 days only

Test mode:	802.11n20	Channel:	Lowest
-------------------	------------------	-----------------	---------------

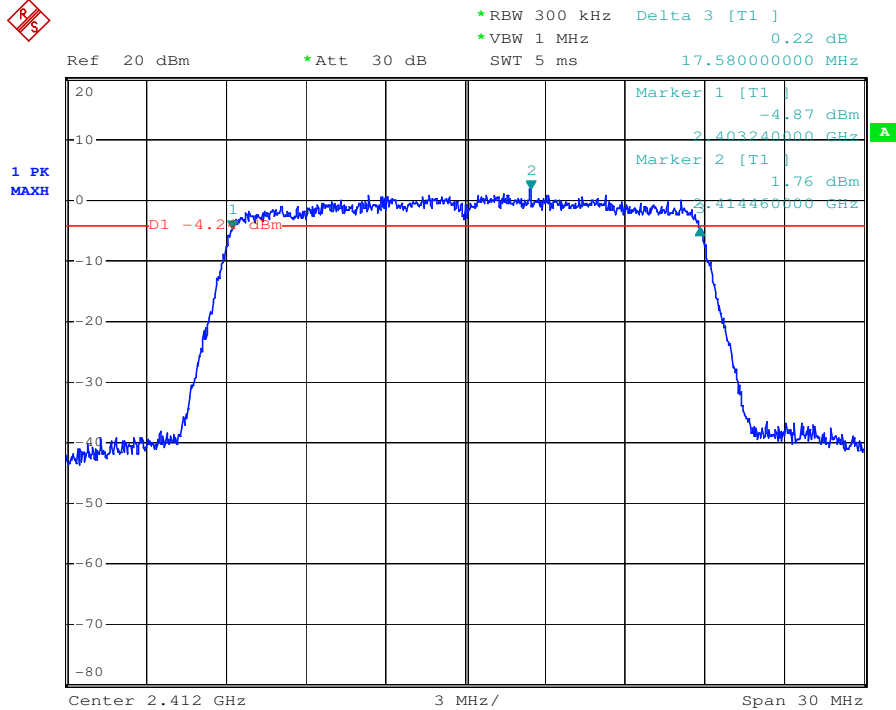

Test mode:	802.11n20	Channel:	Middle
-------------------	------------------	-----------------	---------------

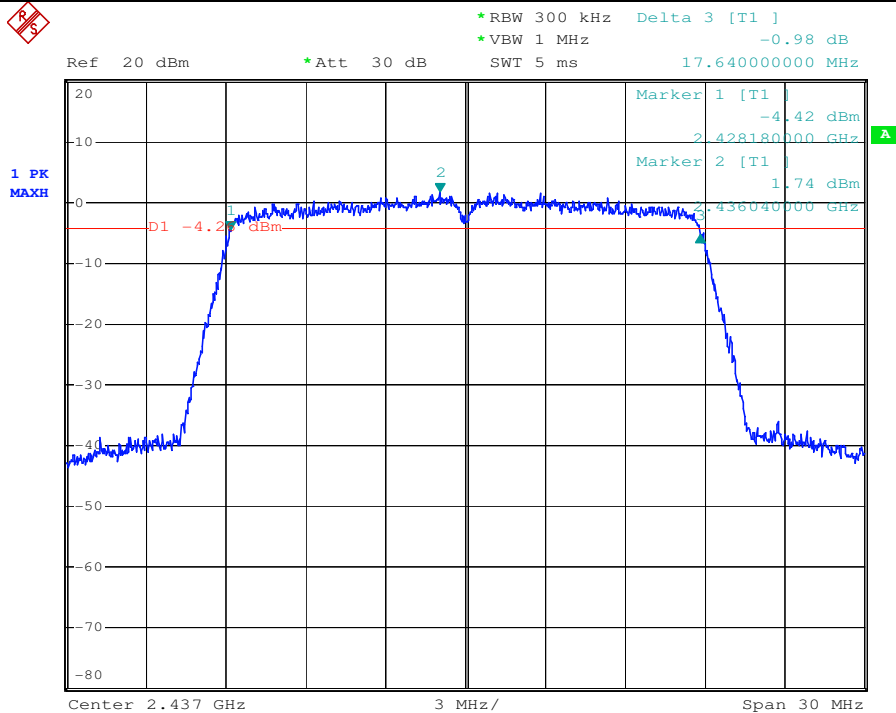

Test mode:	802.11n20	Channel:	Highest
-------------------	------------------	-----------------	----------------

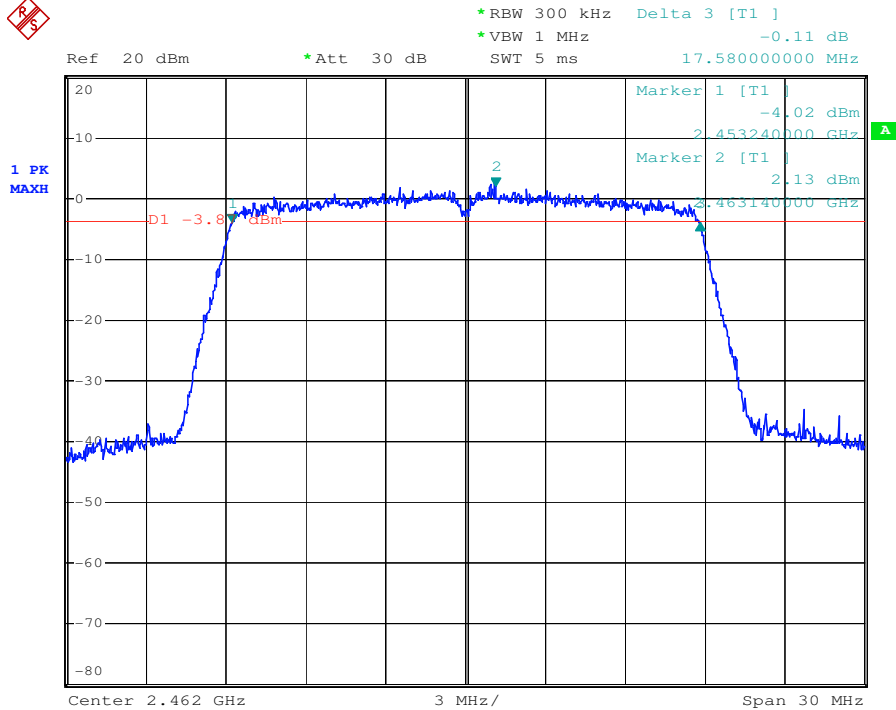

Test mode:	802.11n40	Channel:	Lowest
-------------------	------------------	-----------------	---------------

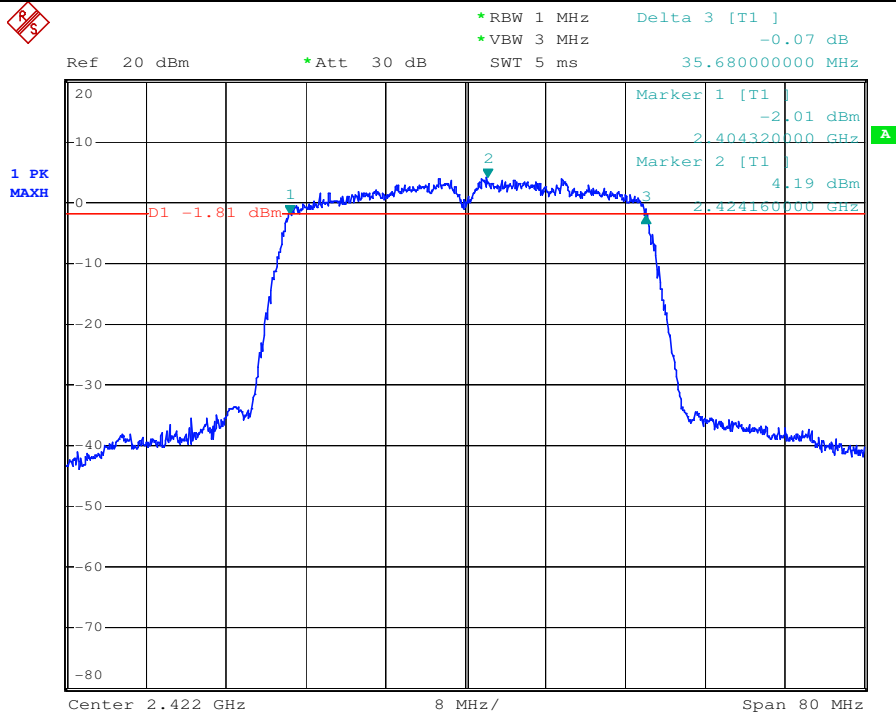

Test mode:	802.11n40	Channel:	Middle
-------------------	------------------	-----------------	---------------

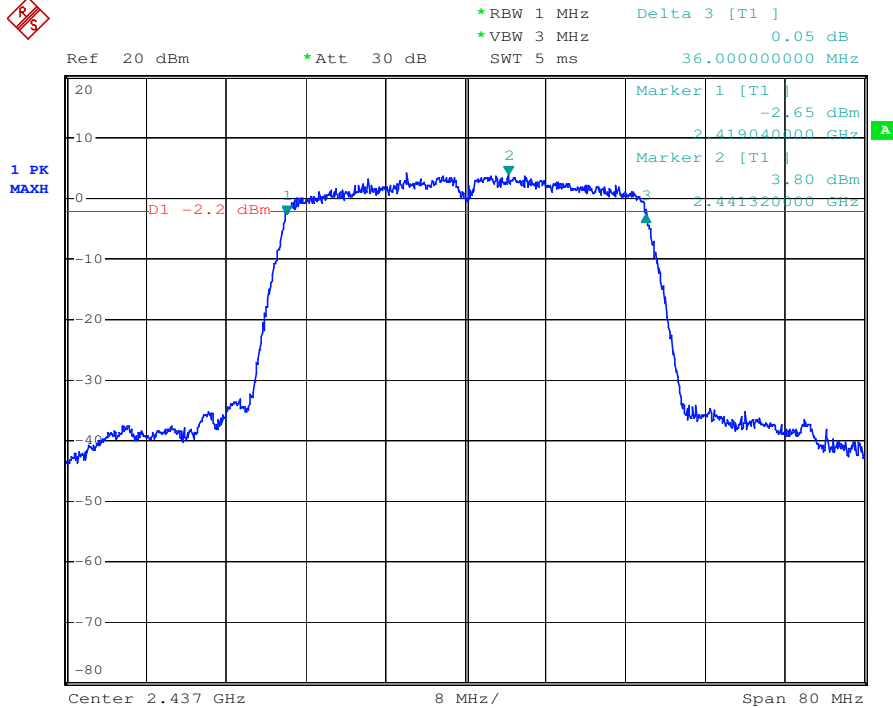

Test mode:	802.11n40	Channel:	Highest
-------------------	------------------	-----------------	----------------

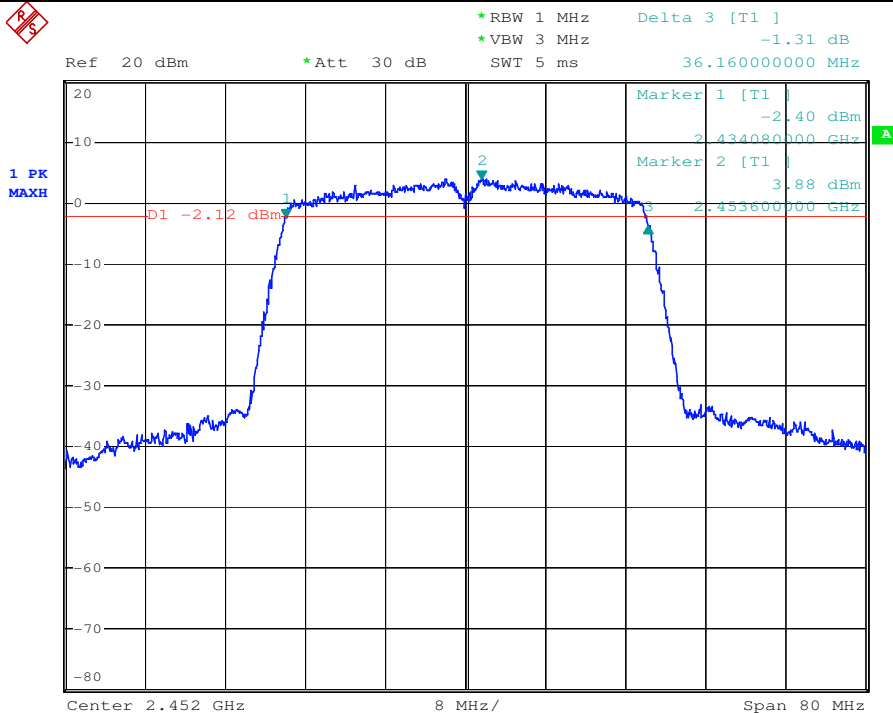

7.5 Conducted Peak Output Power

Test Configuration:

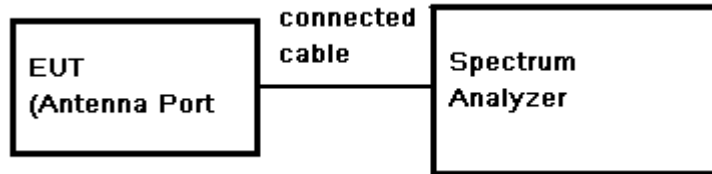

Test Procedure:

1. Place the EUT on the table and set it in transmitting mode.
2. Remove the antenna from the EUT and then connect a low loss RF cable from the antenna port to the spectrum.
3. Set the occur band to the entire emission 6dB bandwidth of the signal.
4. Record the max. Power channel reading.
5. Repeat above procedures until all the frequency measured were complete.

Test Limit: 30dBm

Test Result: Pass

Test Data:

Test mode	Test Channel	Reading Power (dBm)	Cable Loss (dB)	Output Power (dBm)	Output Power (mW)	Power Limit (dBm)	Result
802.11b	Lowest	14.71	0.5	15.21	33.19	30	PASS
	Middle	14.57	0.5	15.07	32.14	30	PASS
	Highest	14.75	0.5	15.25	33.50	30	PASS
802.11g	Lowest	17.39	0.5	17.89	61.52	30	PASS
	Middle	17.46	0.5	17.96	62.52	30	PASS
	Highest	17.35	0.5	17.85	60.95	30	PASS
802.11n20	Lowest	17.16	0.5	17.66	58.34	30	PASS
	Middle	17.26	0.5	17.76	59.70	30	PASS
	Highest	17.25	0.5	17.75	59.57	30	PASS
802.11n40	Lowest	17.15	0.5	17.65	58.21	30	PASS
	Middle	17.22	0.5	17.72	59.16	30	PASS
	Highest	17.27	0.5	17.77	59.84	30	PASS

Remark: Output Peak Power = Reading Peak Power + Cable loss

Test result plot as follows:

Test mode:	802.11b	Channel:	Lowest
-------------------	----------------	-----------------	---------------

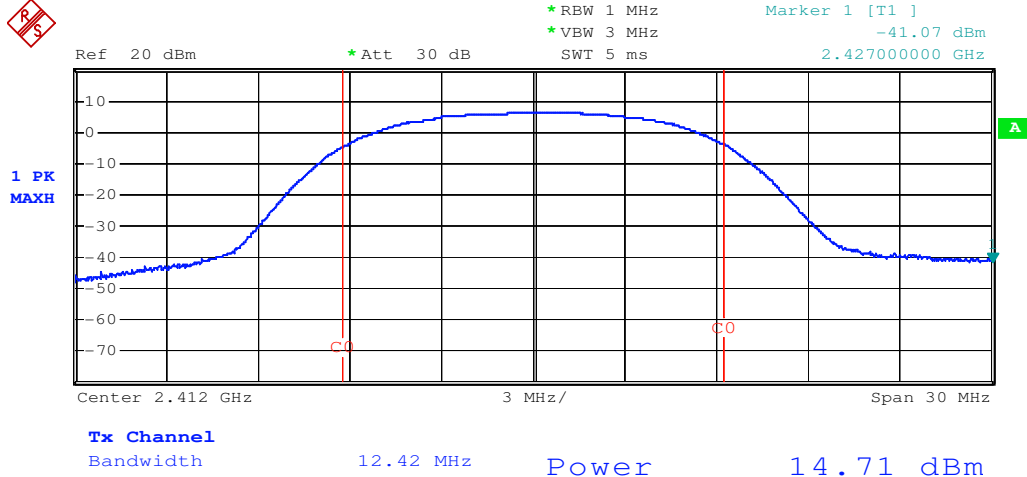

Test mode:	802.11b	Channel:	Middle
-------------------	----------------	-----------------	---------------

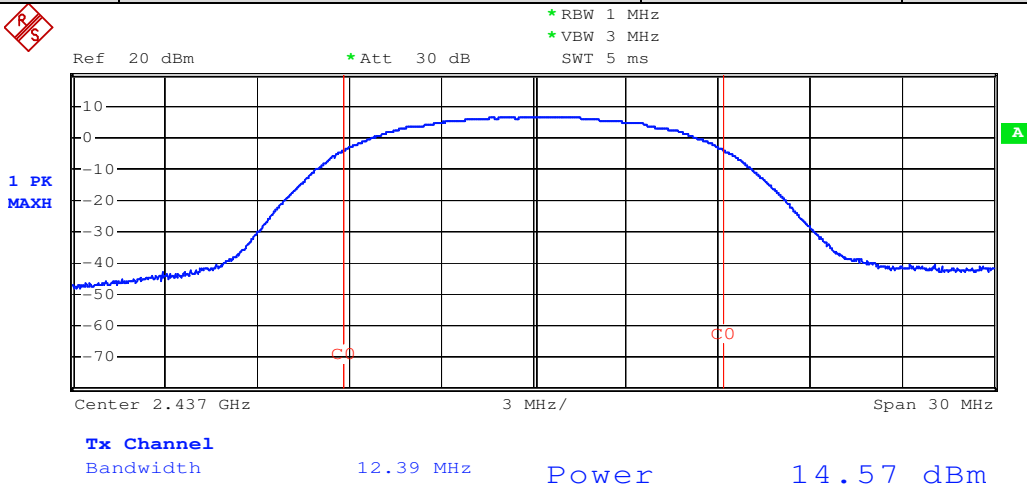

Test mode:	802.11b	Channel:	Highest
-------------------	----------------	-----------------	----------------

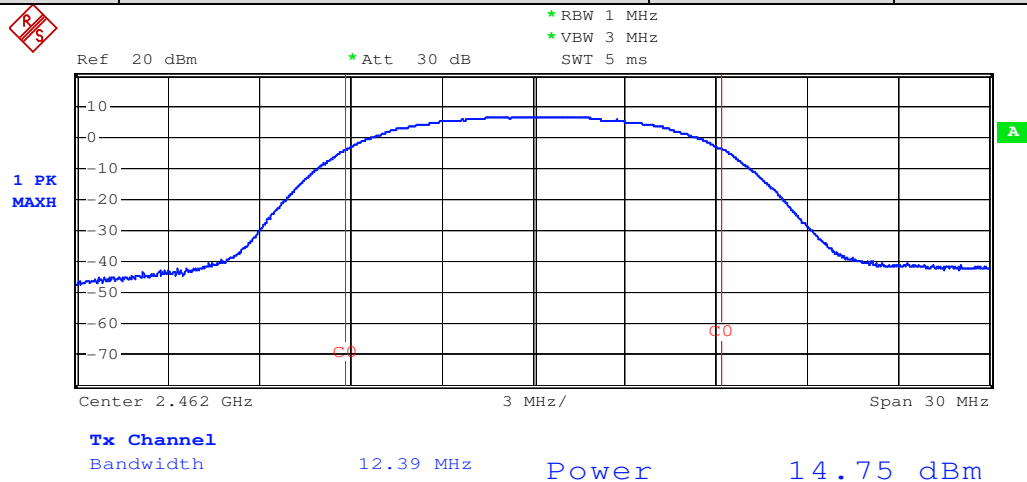

Test mode:	802.11g	Channel:	Lowest
-------------------	----------------	-----------------	---------------

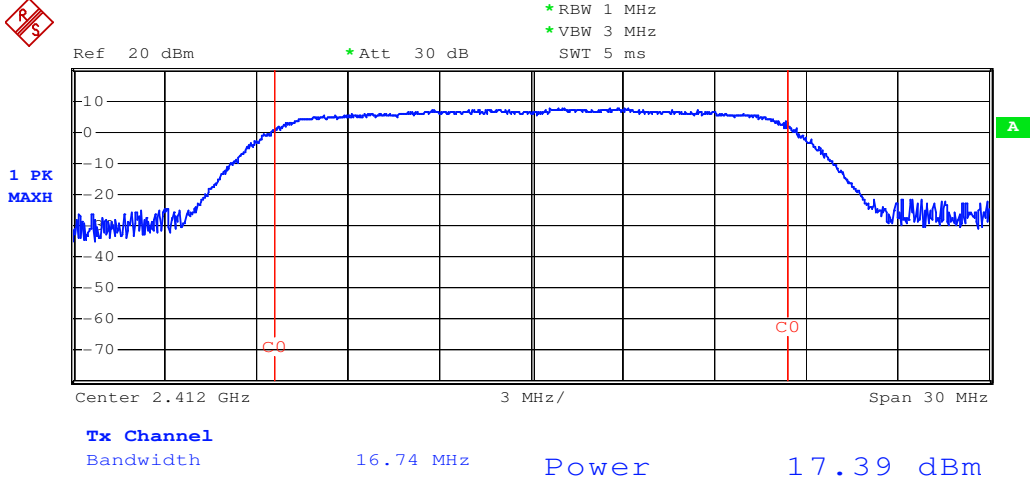

Test mode:	802.11g	Channel:	Middle
-------------------	----------------	-----------------	---------------

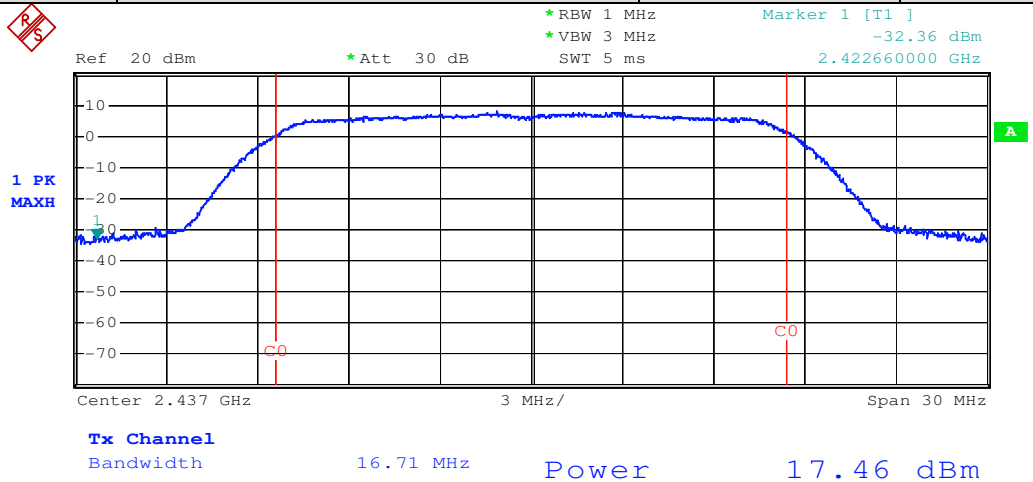

Test mode:	802.11g	Channel:	Highest
-------------------	----------------	-----------------	----------------

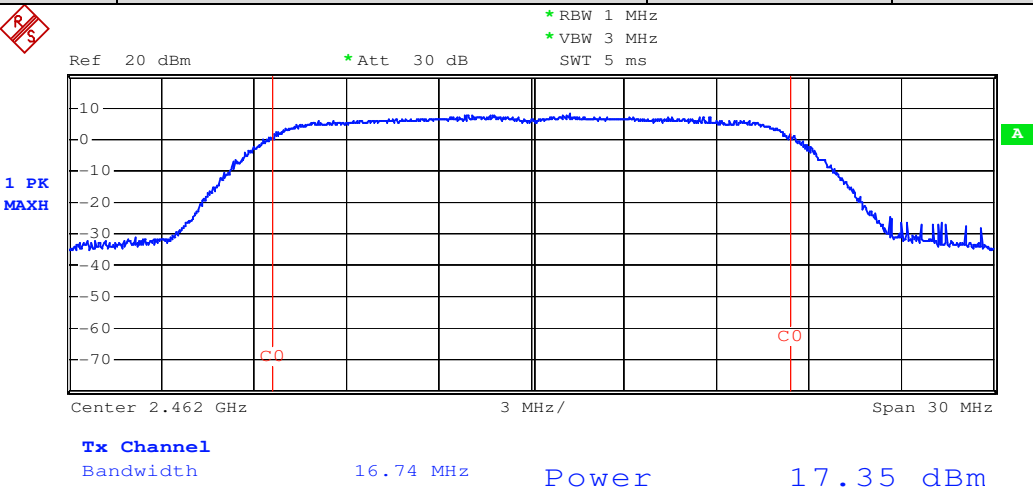

This document is issued by the Company subject to its General Conditions of Service printed overleaf, available on request or accessible at www.sgs.com/terms_and_conditions.htm and, for electronic format documents, subject to Terms and Conditions for Electronic Documents at www.sgs.com/terms_e-document.htm. Attention is drawn to the limitation of liability, indemnification and jurisdiction issues defined therein. Any holder of this document is advised that information contained hereon reflects the Company's findings at the time of its intervention only and within the limits of Client's instructions, if any. The Company's sole responsibility is to its Client and this document does not exonerate parties to a transaction from exercising all their rights and obligations under the transaction documents. This document cannot be reproduced except in full, without prior written approval of the Company. Any unauthorized alteration, forgery or falsification of the content or appearance of this document is unlawful and offenders may be prosecuted to the fullest extent of the law. Unless otherwise stated the results shown in this test report refer only to the sample(s) tested and such sample(s) are retained for 90 days only

Test mode:	802.11n20	Channel:	Lowest
-------------------	------------------	-----------------	---------------

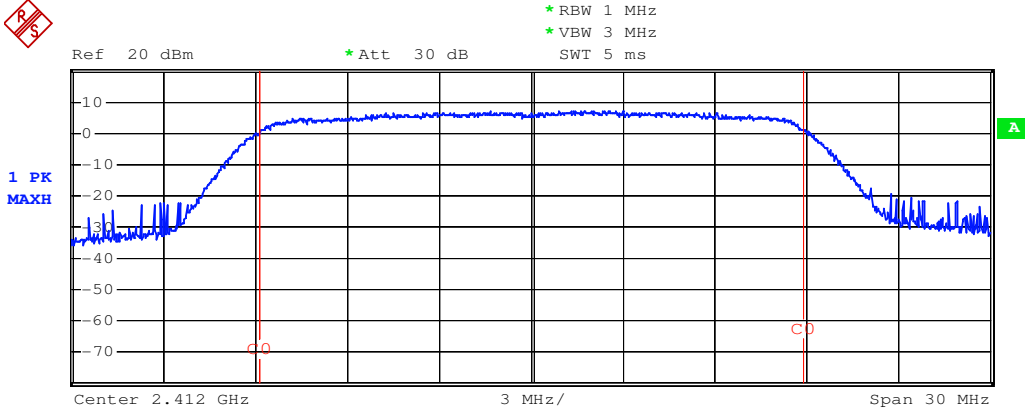

Test mode:	802.11n20	Channel:	Middle
-------------------	------------------	-----------------	---------------

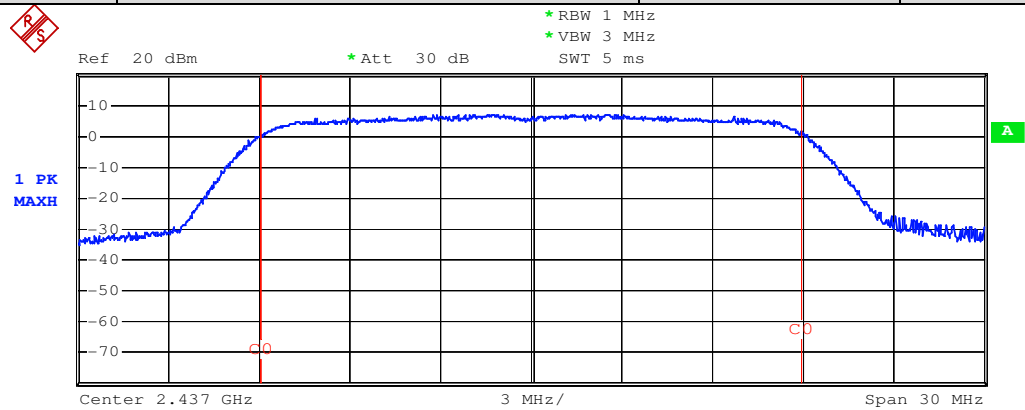

Test mode:	802.11n20	Channel:	Highest
-------------------	------------------	-----------------	----------------

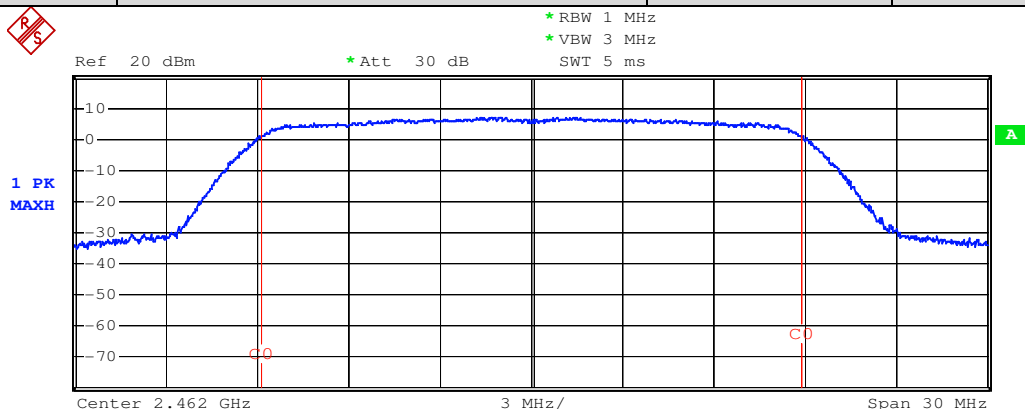

Test mode:	802.11n40	Channel:	Lowest
-------------------	------------------	-----------------	---------------

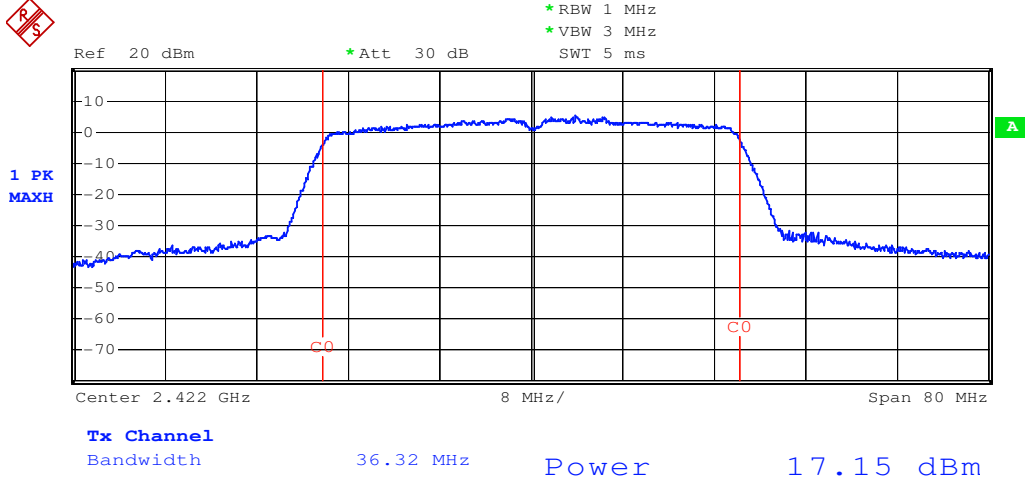

Test mode:	802.11n40	Channel:	Middle
-------------------	------------------	-----------------	---------------

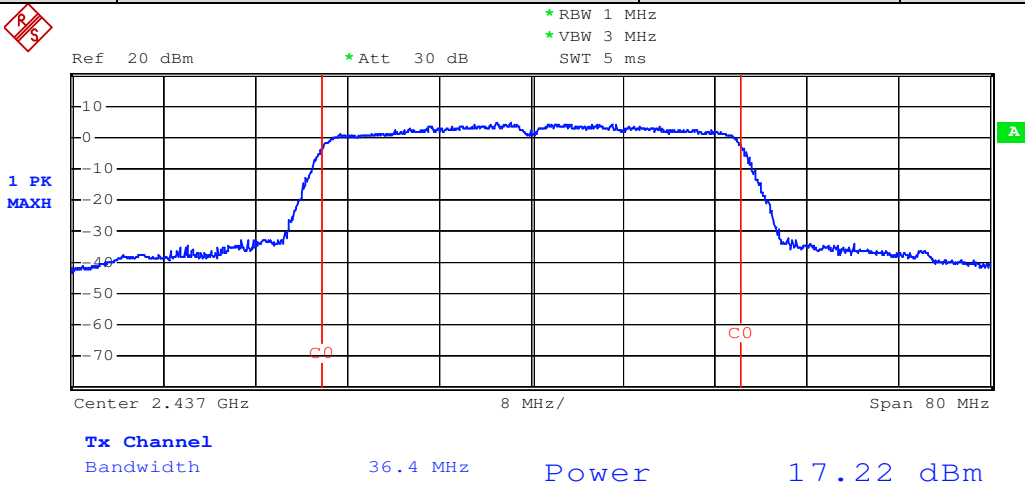

Test mode:	802.11n40	Channel:	Highest
-------------------	------------------	-----------------	----------------

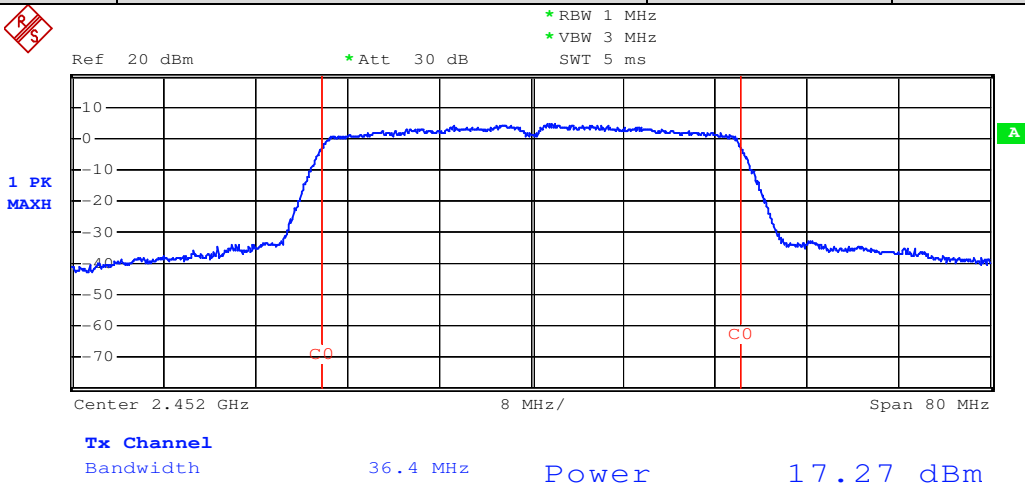

This document is issued by the Company subject to its General Conditions of Service printed overleaf, available on request or accessible at www.sgs.com/terms_and_conditions.htm and, for electronic format documents, subject to Terms and Conditions for Electronic Documents at www.sgs.com/terms_e_document.htm. Attention is drawn to the limitation of liability, indemnification and jurisdiction issues defined therein. Any holder of this document is advised that information contained hereon reflects the Company's findings at the time of its intervention only and within the limits of Client's instructions, if any. The Company's sole responsibility is to its Client and this document does not exonerate parties to a transaction from exercising all their rights and obligations under the transaction documents. This document cannot be reproduced except in full, without prior written approval of the Company. Any unauthorized alteration, forgery or falsification of the content or appearance of this document is unlawful and offenders may be prosecuted to the fullest extent of the law. Unless otherwise stated the results shown in this test report refer only to the sample(s) tested and such sample(s) are retained for 90 days only

7.6 Peak Power Spectral Density

Test Configuration:

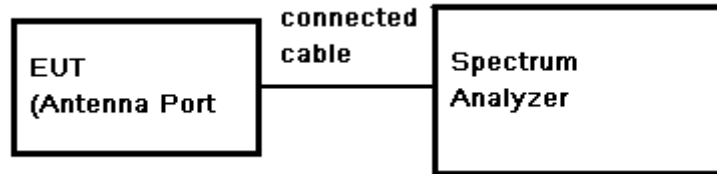

Test Procedure:

1. Remove the antenna from the EUT and then connect a low RF cable from the antenna port to the spectrum.
2. Set the spectrum analyzer: Center Frequency= Channel Frequency, RBW = 3 kHz VBW = 10 kHz. Span= fully encompass the bandwidth, Sweep = auto; Detector Function = Peak Trace mode=max hold,
3. Set MKR=Center Frequency, Trace=Clear Write.
4. Adjust the Span = 300 kHz, Sweep Time=100s, Trace=Max Hold, MKR=Peak Search.
5. Record the marker level for the particular mode.
6. Repeat these steps for other channel and device modes.

Test Limit:

8dBm/3kHz

Test Result:

Pass

Test Data:

Test mode: 802.11b

CH	Frequency (MHz)	Reading (dBm)	Cable Loss (dB)	RF Power Density (dBm)	Limit (dBm)	Result
LOW	2412	-16.94	0.5	-16.44	8	PASS
MID	2437	-15.05	0.5	-14.55	8	PASS
HIGH	2462	-16.23	0.5	-15.73	8	PASS

Test mode: 802.11g

CH	Frequency (MHz)	Reading (dBm)	Cable Loss (dB)	RF Power Density (dBm)	Limit (dBm)	Result
LOW	2412	-18.00	0.5	-17.50	8	PASS
MID	2437	16.71	0.5	17.21	8	PASS
HIGH	2462	-16.53	0.5	-16.03	8	PASS

Test mode: 802.11n20

CH	Frequency (MHz)	Reading (dBm)	Cable Loss (dB)	RF Power Density (dBm)	Limit (dBm)	Result
LOW	2412	-15.77	0.5	-15.27	8	PASS
MID	2437	-17.20	0.5	-16.70	8	PASS
HIGH	2462	-17.52	0.5	-17.02	8	PASS

Test mode: 802.11n40

CH	Frequency (MHz)	Reading (dBm)	Cable Loss (dB)	RF Power Density (dBm)	Limit (dBm)	Result
LOW	2422	-22.21	0.5	-21.71	8	PASS
MID	2437	-20.40	0.5	-19.90	8	PASS
HIGH	2452	-21.96	0.5	-21.46	8	PASS

Remark: RF Power Density = Reading + Cable loss + Antenna Gain

Test result plot as follows:

Test mode:	802.11b	Channel:	Lowest
------------	---------	----------	--------



Ref 20 dBm *Att 30 dB *RBW 3 kHz Marker 1 [T1] -16.76 dBm
 *VBW 10 kHz 2.410240000 GHz
 *SWT 2.25 s

1 PK
MAXH

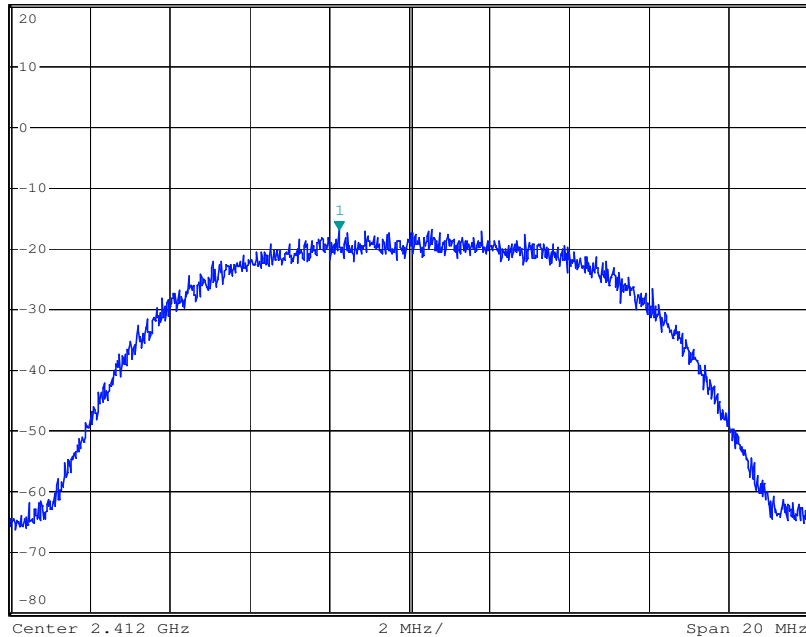

Ref 20 dBm *Att 30 dB *RBW 3 kHz Marker 1 [T1] -16.94 dBm
 *VBW 10 kHz 2.410235200 GHz
 *SWT 100 s

1 PK
MAXH

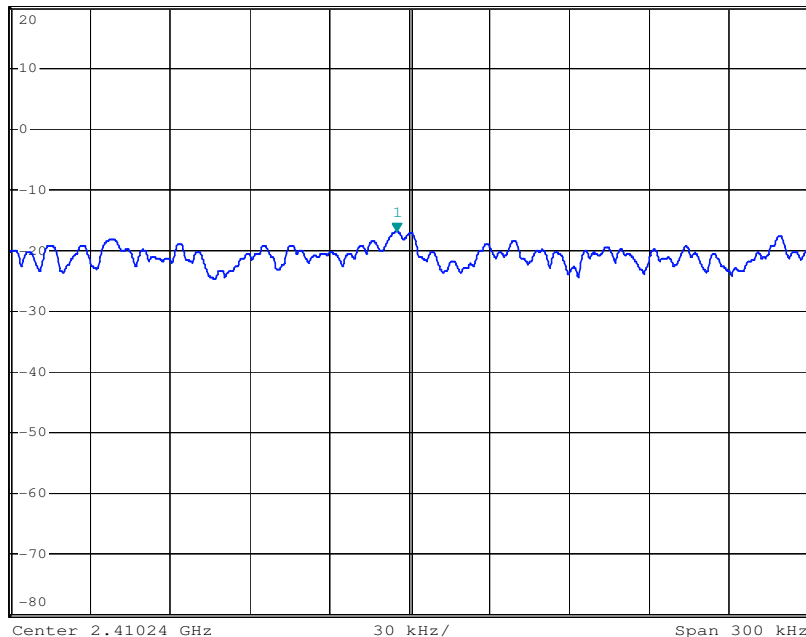

Test mode:	802.11b	Channel:	Middle
-------------------	----------------	-----------------	---------------



*RBW 3 kHz Marker 1 [T1]
 *VBW 10 kHz -15.27 dBm
 Ref 20 dBm *Att 30 dB SWT 2.25 s 2.43850000 GHz

1 PK
MAXH

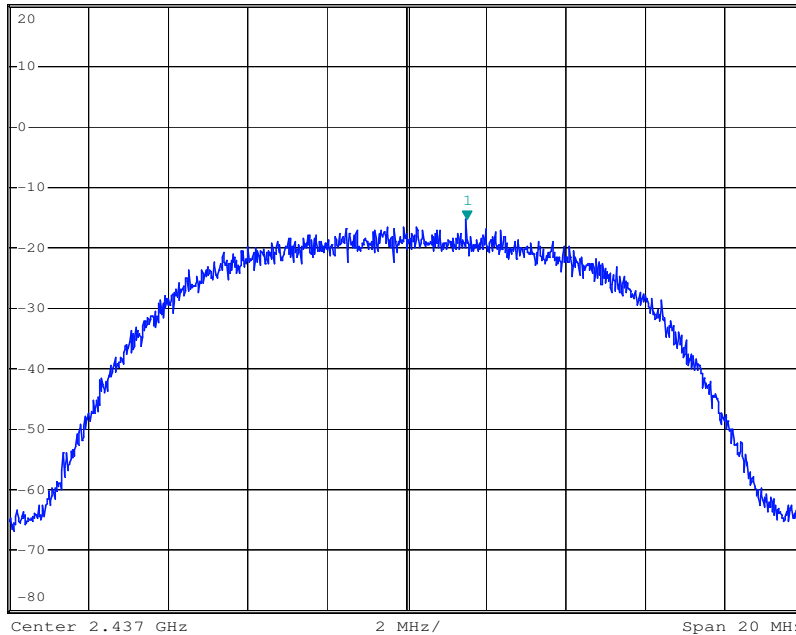

Center 2.437 GHz 2 MHz/ Span 20 MHz



*RBW 3 kHz Marker 1 [T1]
 *VBW 10 kHz -15.05 dBm
 Ref 20 dBm *Att 30 dB *SWT 100 s 2.438495500 GHz

1 PK
MAXH

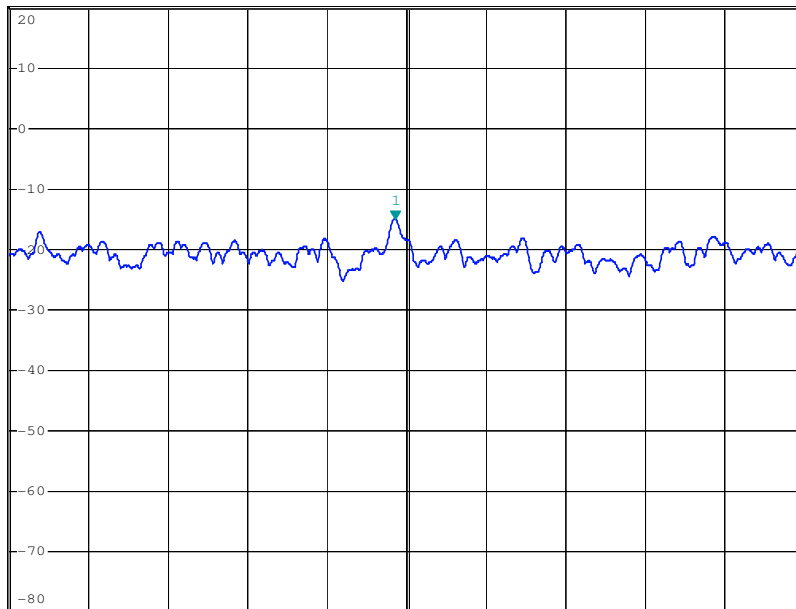

Center 2.4385 GHz 30 kHz/ Span 300 kHz

Test mode:	802.11b	Channel:	Highest
-------------------	----------------	-----------------	----------------



Ref 20 dBm *Att 30 dB *RBW 3 kHz Marker 1 [T1]
 *VBW 10 kHz -15.65 dBm
 SWT 2.25 s 2.461640000 GHz

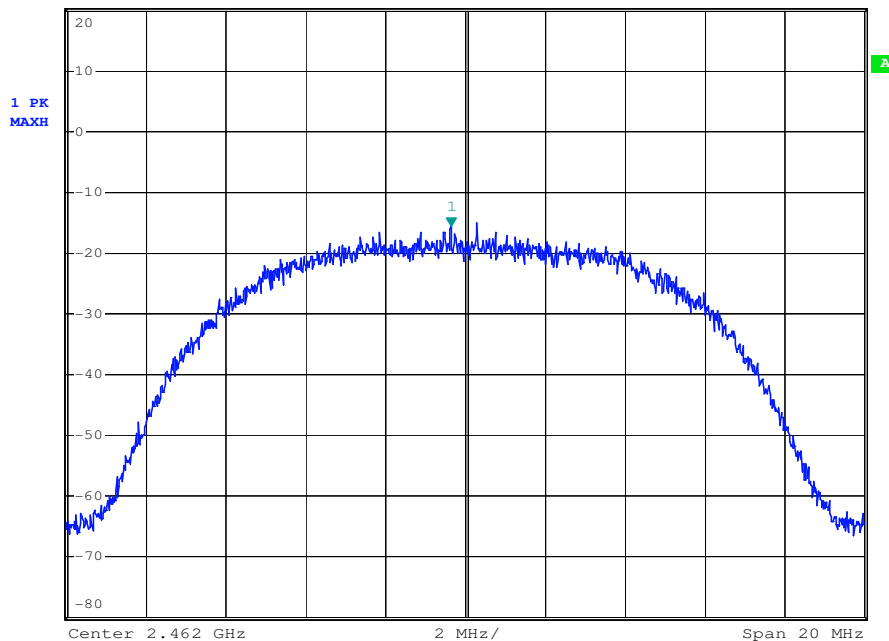

Ref 20 dBm *Att 30 dB *RBW 3 kHz Marker 1 [T1]
 *VBW 10 kHz -16.23 dBm
 *SWT 100 s 2.461629800 GHz

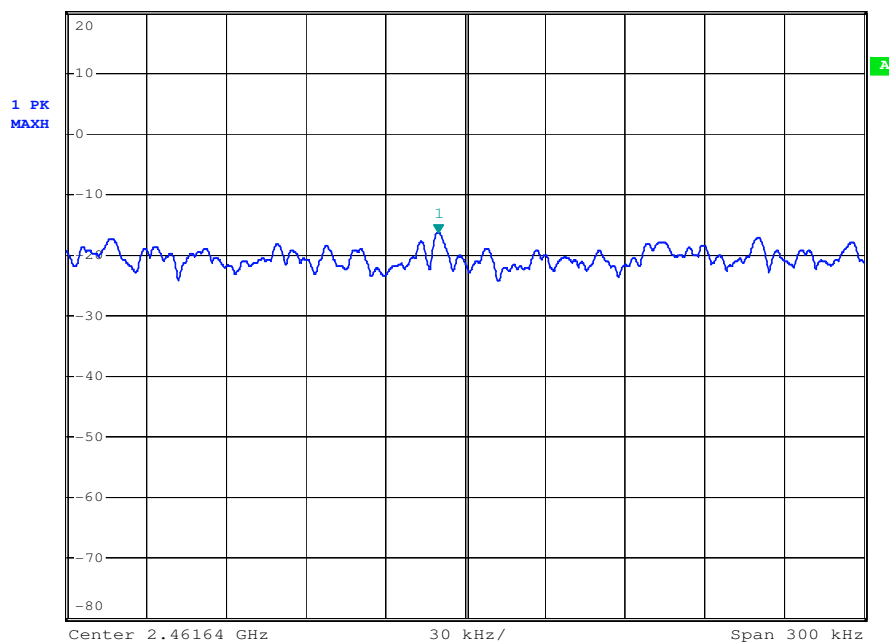

Test mode:	802.11g	Channel:	Lowest
-------------------	----------------	-----------------	---------------



Ref 20 dBm *Att 30 dB *RBW 3 kHz Marker 1 [T1] -18.66 dBm
 *VBW 10 kHz 2.412580000 GHz
 *SWT 2.25 s

1 PK
MAXH

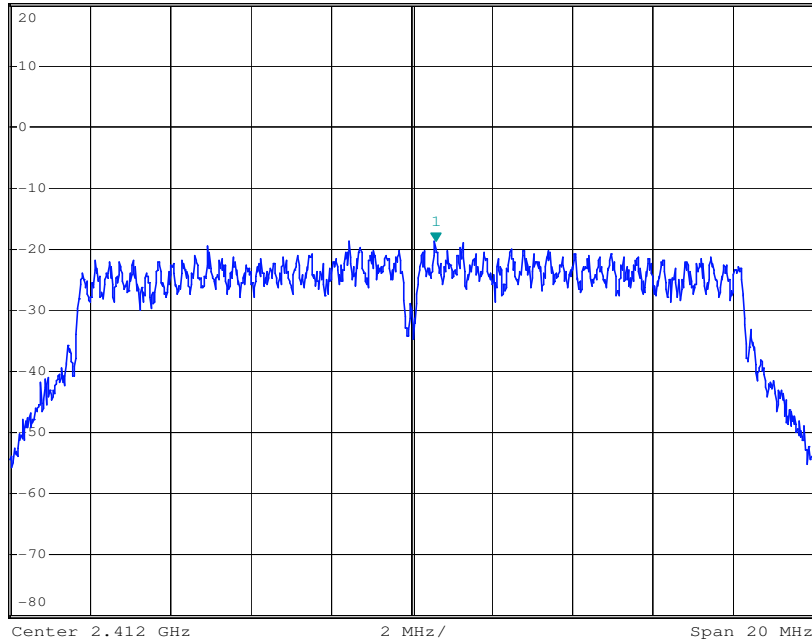

Ref 20 dBm *Att 30 dB *RBW 3 kHz Marker 1 [T1] -18.00 dBm
 *VBW 10 kHz 2.412579100 GHz
 *SWT 100 s

1 PK
MAXH

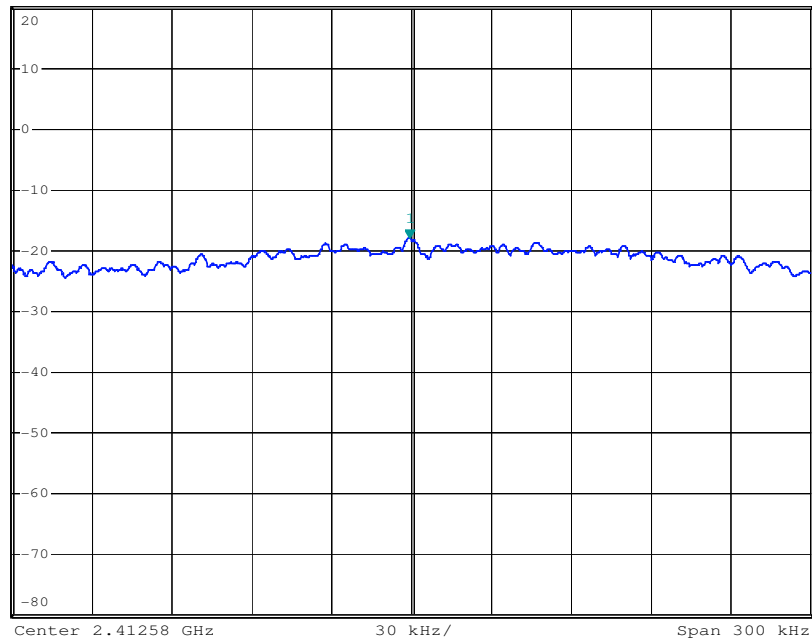

Test mode:	802.11g	Channel:	Middle
-------------------	----------------	-----------------	---------------



*RBW 3 kHz Marker 1 [T1]
 *VBW 10 kHz -18.81 dBm
 Ref 20 dBm *Att 30 dB SWT 2.25 s 2.435720000 GHz

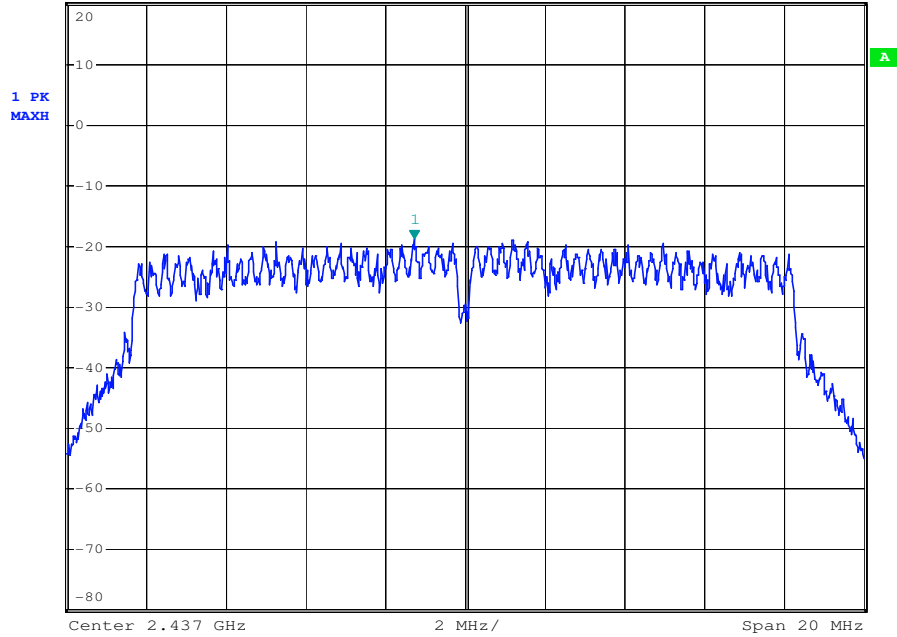

*RBW 3 kHz Marker 1 [T1]
 *VBW 10 kHz -16.71 dBm
 Ref 20 dBm *Att 30 dB *SWT 100 s 2.435728100 GHz

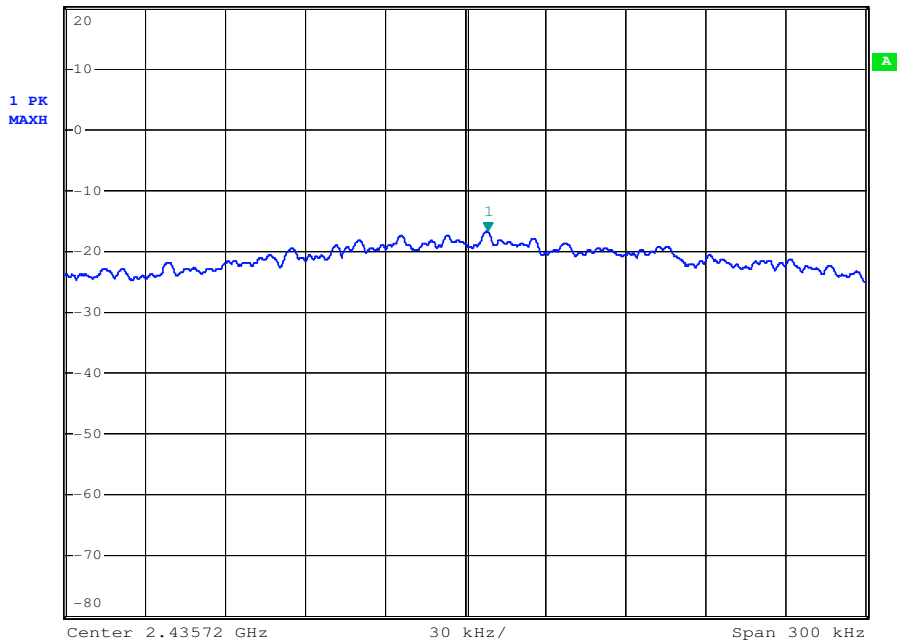

Test mode:	802.11g	Channel:	Highest
-------------------	----------------	-----------------	----------------



*RBW 3 kHz Marker 1 [T1]
 *VBW 10 kHz -18.45 dBm
 Ref 20 dBm *Att 30 dB SWT 2.25 s 2.463240000 GHz

1 PK
MAXH

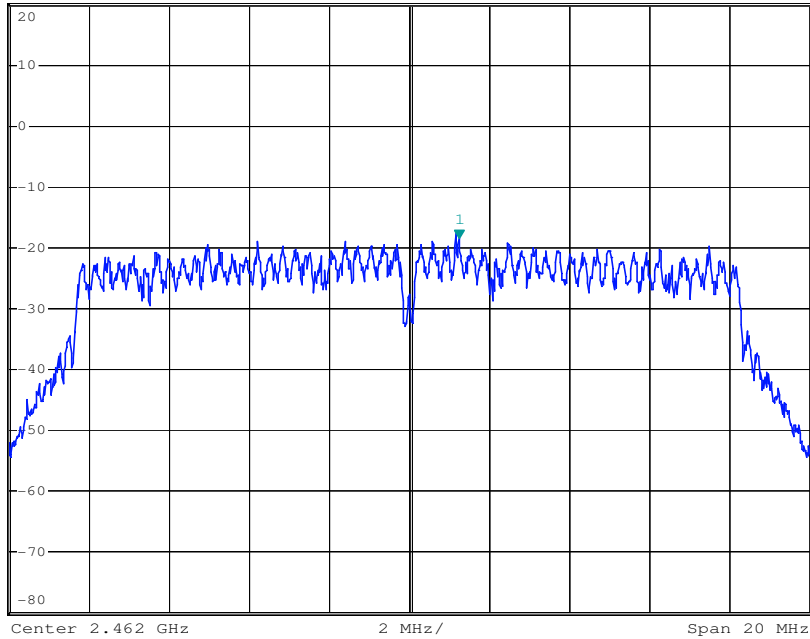

*RBW 3 kHz Marker 1 [T1]
 *VBW 10 kHz -16.53 dBm
 Ref 20 dBm *Att 30 dB *SWT 100 s 2.463157800 GHz

1 PK
MAXH

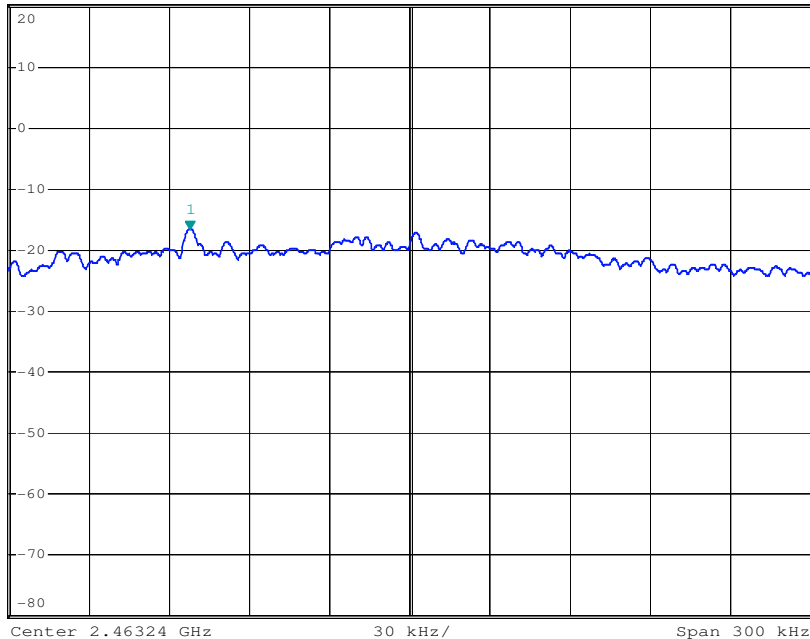

Test mode:	802.11n20	Channel:	Lowest
-------------------	------------------	-----------------	---------------



Ref 20 dBm *Att 30 dB *RBW 3 kHz Marker 1 [T1] -18.08 dBm
 *VBW 10 kHz 2.41072000 GHz
 *SWT 2.25 s

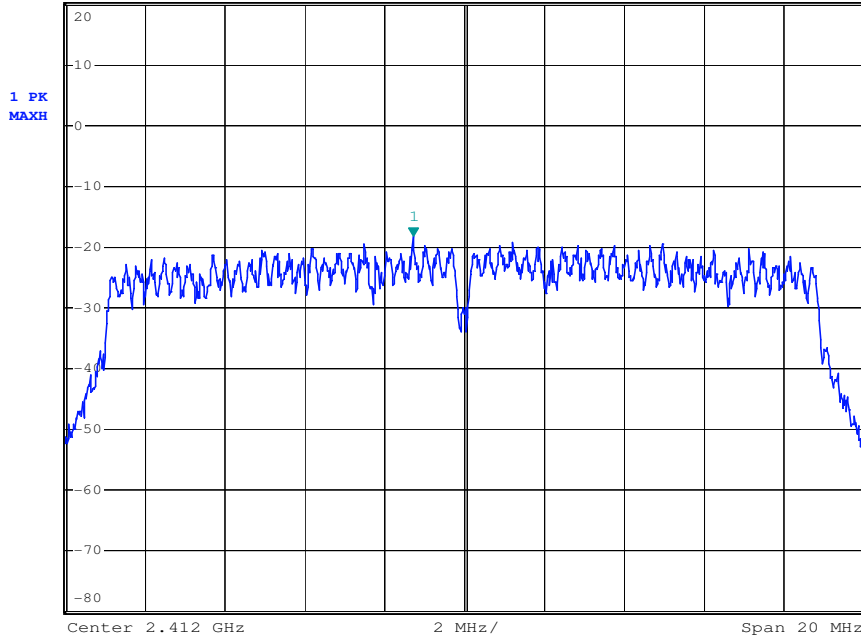

Ref 20 dBm *Att 30 dB *RBW 3 kHz Marker 1 [T1] -15.77 dBm
 *VBW 10 kHz 2.410723300 GHz
 *SWT 100 s

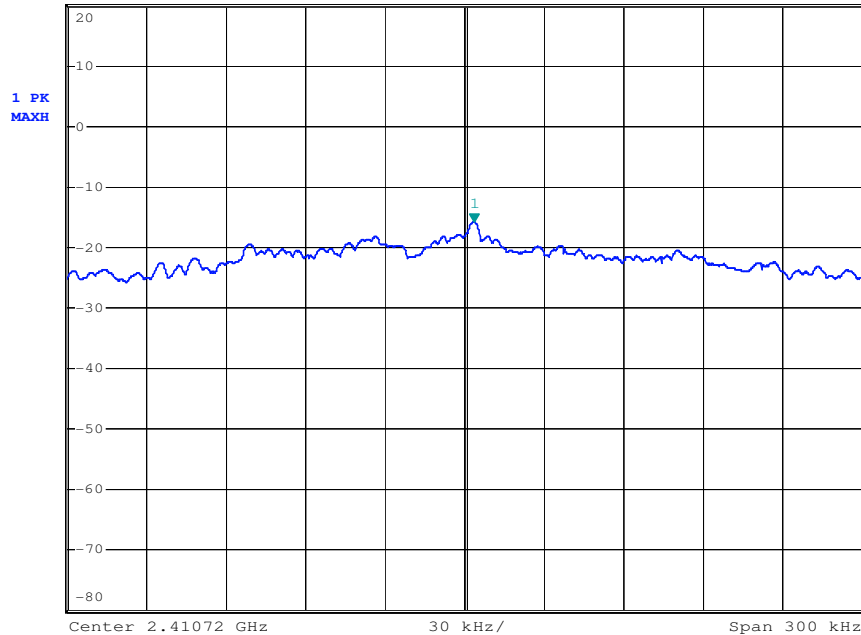

Test mode:	802.11n20	Channel:	Middle
-------------------	------------------	-----------------	---------------



Ref 20 dBm *Att 30 dB *RBW 3 kHz Marker 1 [T1] -18.28 dBm
 *VBW 10 kHz 2.435720000 GHz
 SWT 2.25 s

1 PK
MAXH

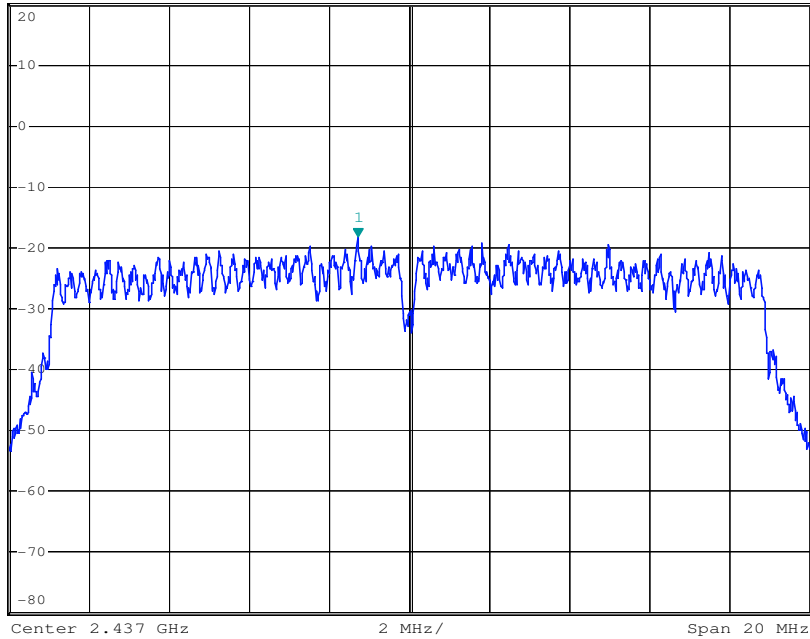

Ref 20 dBm *Att 30 dB *RBW 3 kHz Marker 1 [T1] -17.20 dBm
 *VBW 10 kHz 2.435718200 GHz
 *SWT 100 s

1 PK
MAXH

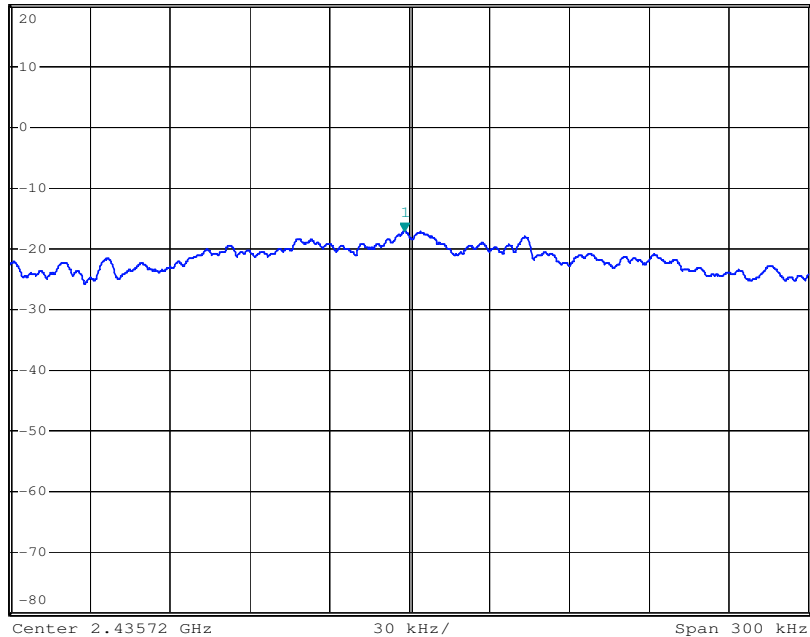

Test mode:	802.11n20	Channel:	Highest
-------------------	------------------	-----------------	----------------



*RBW 3 kHz Marker 1 [T1]
 *VBW 10 kHz -19.98 dBm
 Ref 20 dBm *Att 30 dB SWT 2.25 s 2.460680000 GHz

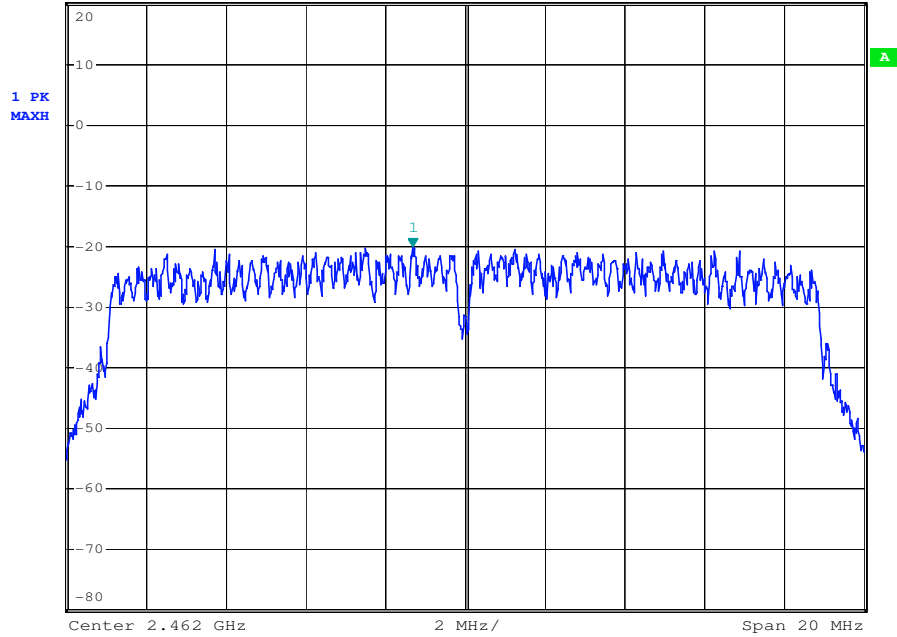

*RBW 3 kHz Marker 1 [T1]
 *VBW 10 kHz -17.52 dBm
 Ref 20 dBm *Att 30 dB *SWT 100 s 2.460714800 GHz

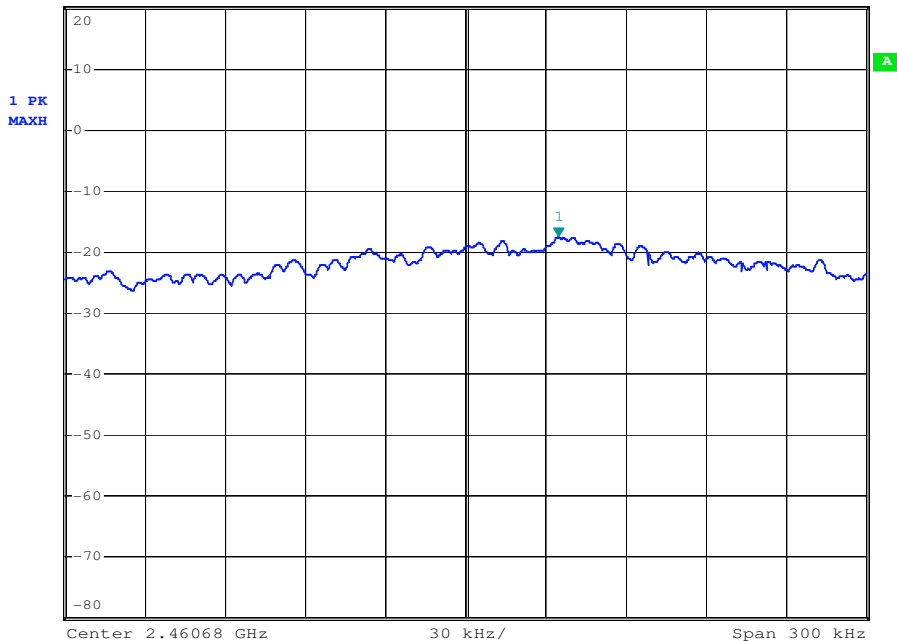

Test mode:	802.11n40	Channel:	Lowest
-------------------	------------------	-----------------	---------------



*RBW 3 kHz Marker 1 [T1]
 *VBW 10 kHz -22.81 dBm
 Ref 20 dBm *Att 30 dB SWT 5.6 s 2.419450000 GHz

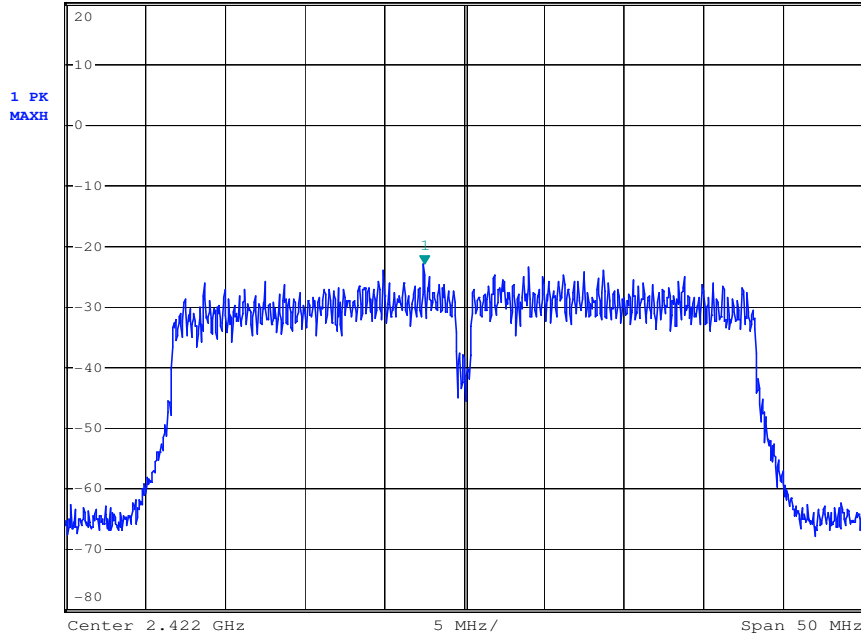

*RBW 3 kHz Marker 1 [T1]
 *VBW 10 kHz -22.21 dBm
 Ref 20 dBm *Att 30 dB *SWT 100 s 2.419463200 GHz

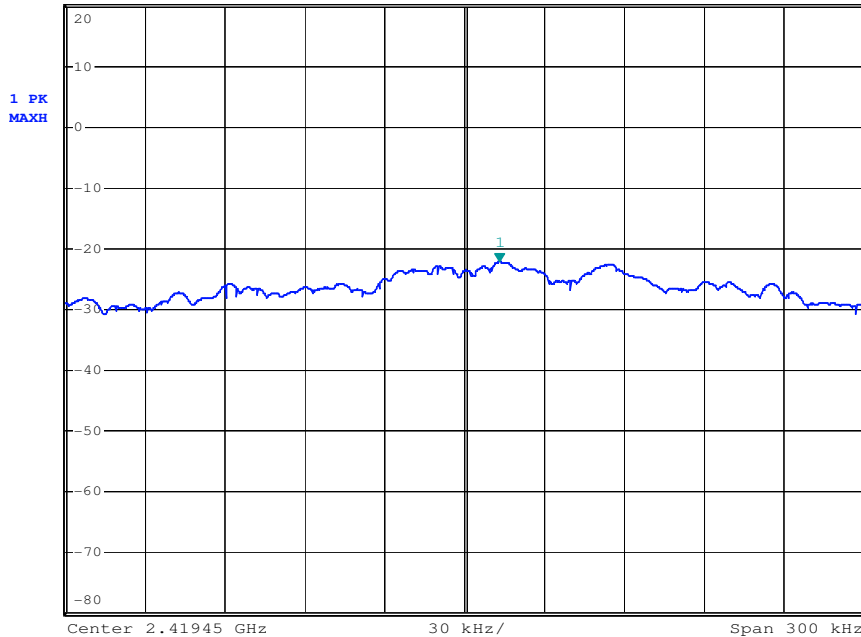



Test mode:	802.11n40	Channel:	Middle
------------	-----------	----------	--------



Ref 20 dBm *Att 30 dB *RBW 3 kHz Marker 1 [T1] -23.74 dBm
*VBW 10 kHz 2.43200000 GHz
SWT 5.6 s

1 PK
MAXH

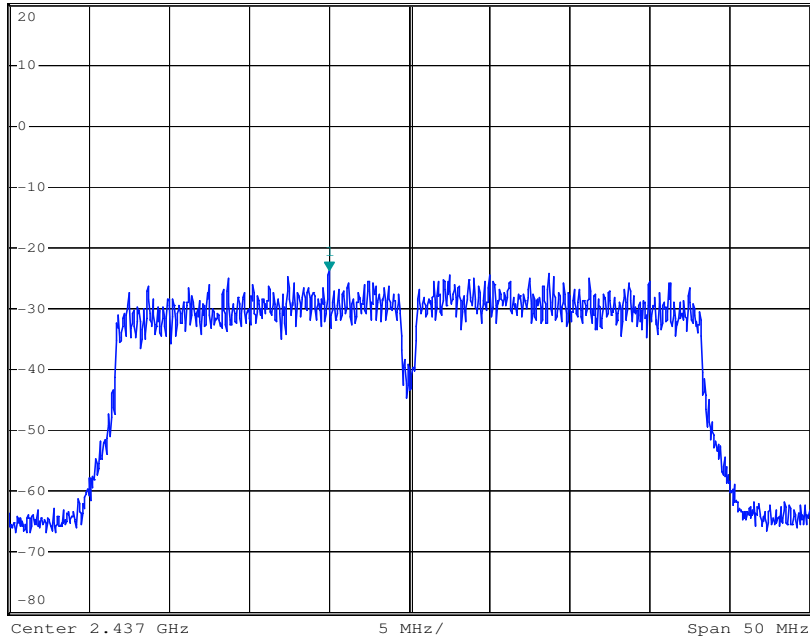

Ref 20 dBm *Att 30 dB *RBW 3 kHz Marker 1 [T1] -20.40 dBm
*VBW 10 kHz 2.431968800 GHz
*SWT 100 s

1 PK
MAXH

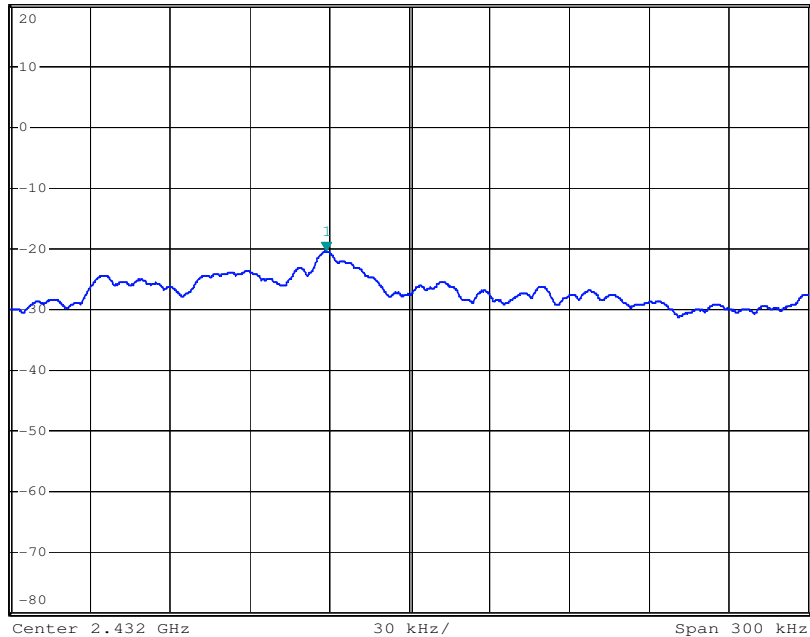

Test mode:	802.11n40	Channel:	Highest
-------------------	------------------	-----------------	----------------



*RBW 3 kHz Marker 1 [T1]
 *VBW 10 kHz -23.23 dBm
 Ref 20 dBm *Att 30 dB SWT 5.6 s 2.446950000 GHz

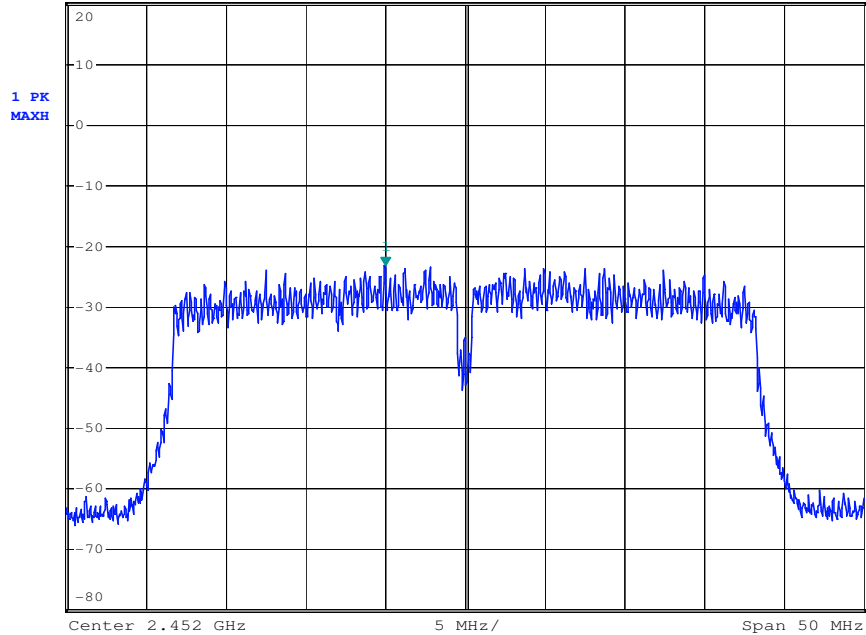

*RBW 3 kHz Marker 1 [T1]
 *VBW 10 kHz -21.96 dBm
 Ref 20 dBm *Att 30 dB *SWT 100 s 2.446976100 GHz

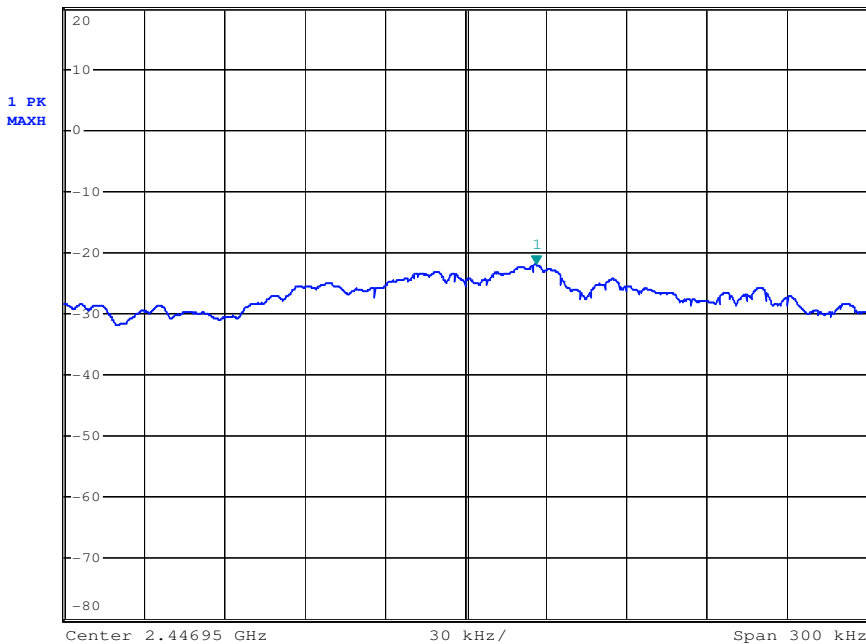

7.7 Conducted Spurious Emissions and Band-edge

Test Configuration:

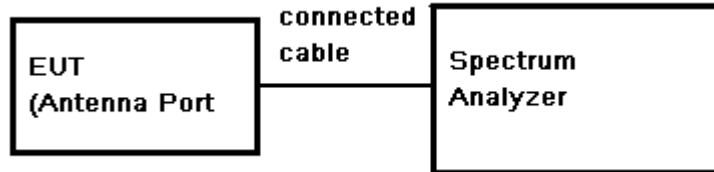

Test Procedure:

1. Remove the antenna from the EUT and then connect a low RF cable from the antenna port to the spectrum.
2. Set the spectrum analyzer: RBW = 100KHz. VBW >= RBW. Sweep = auto; Detector Function = Peak (Max. hold).

Limit:

(d) In any 100 kHz bandwidth outside the frequency band in which the spread spectrum or digitally modulated intentional radiator is operating, the radio frequency power that is produced by the intentional radiator shall be at least 20 dB below that in the 100 kHz bandwidth within the band that contains the Highest level of the desired power, based on either an RF conducted or a radiated measurement, provided the transmitter demonstrates compliance with the peak conducted power limits.

Test Result:

Pass

7.7.1 Conducted spurious emission

Test plot as follows:

Test mode:	802.11b	Channel:	Lowest
-------------------	----------------	-----------------	---------------

30MHz-3GHz:

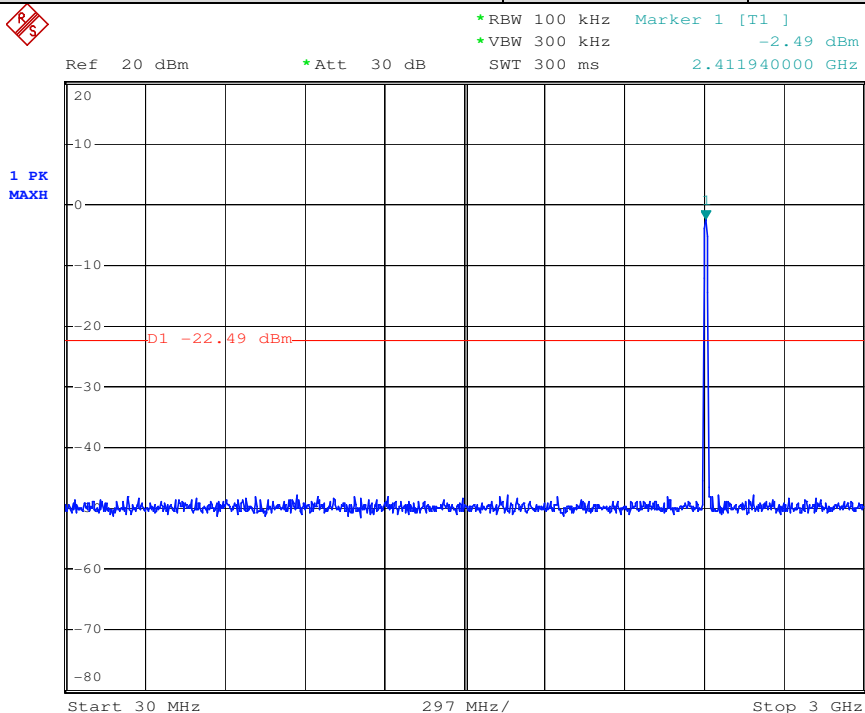

3GHz-25GHz:

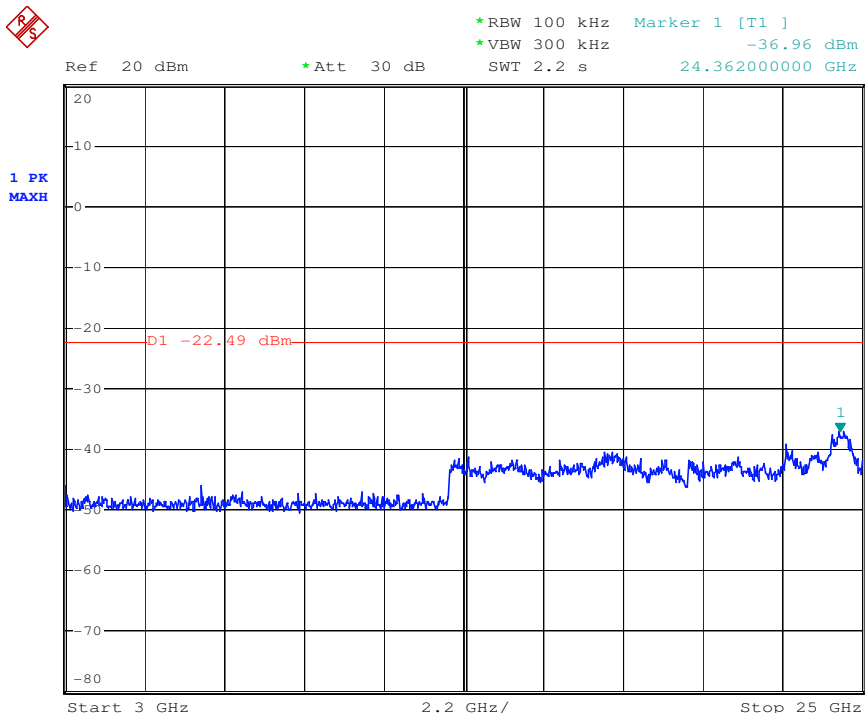

Test mode:	802.11b	Channel:	Middle
-------------------	----------------	-----------------	---------------

30MHz-3GHz:



1 PK
MAXH

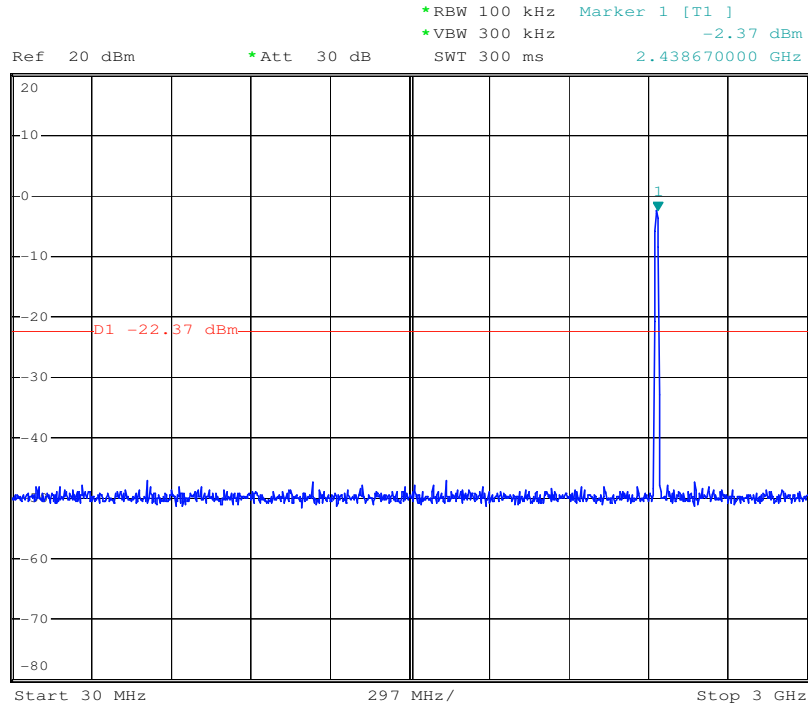

3GHz-25GHz:



1 PK
MAXH

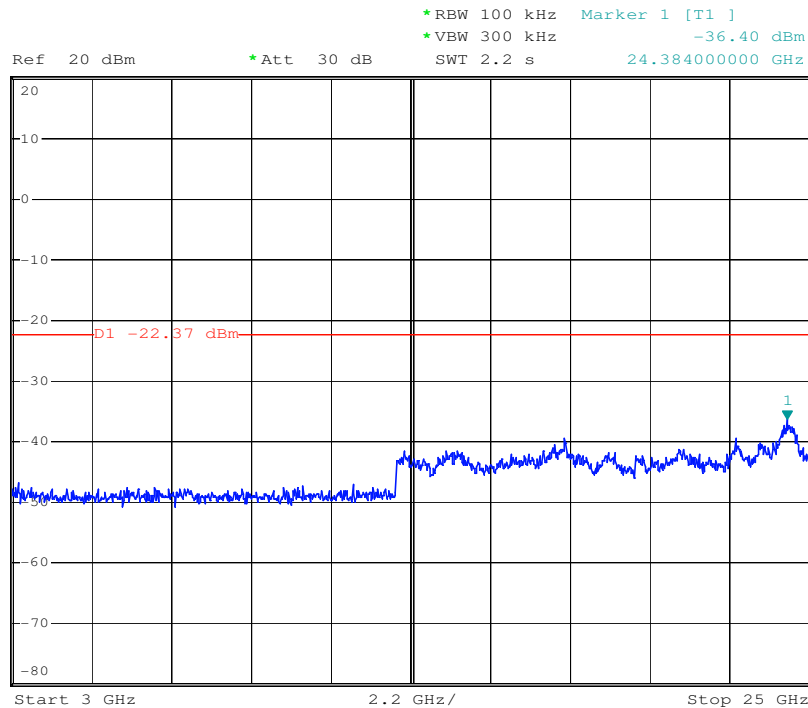

Test mode:	802.11b	Channel:	Highest
-------------------	----------------	-----------------	----------------

30MHz-3GHz:

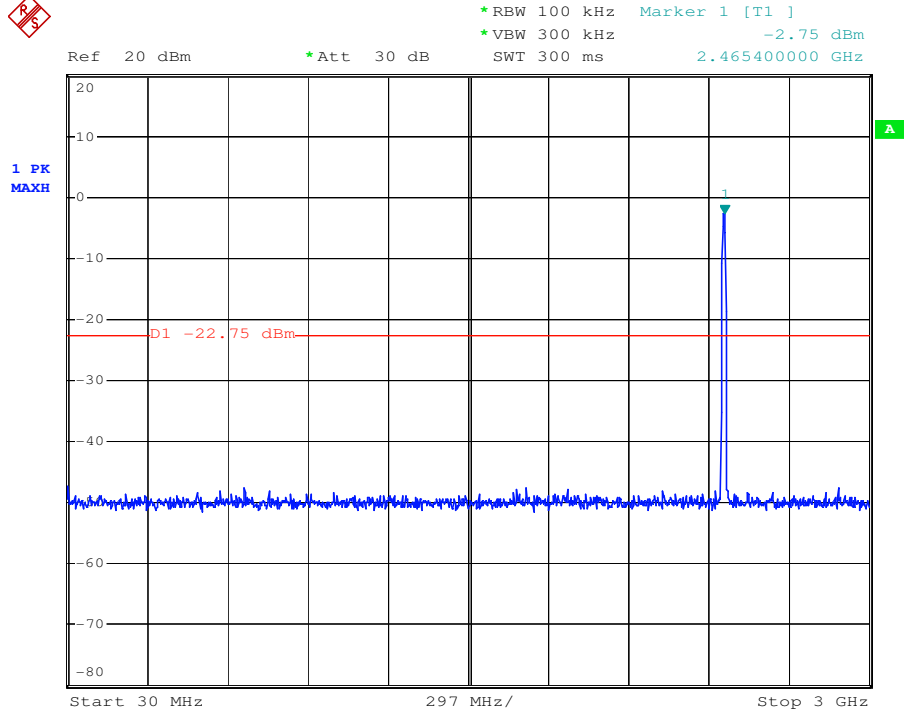

3GHz-25GHz:

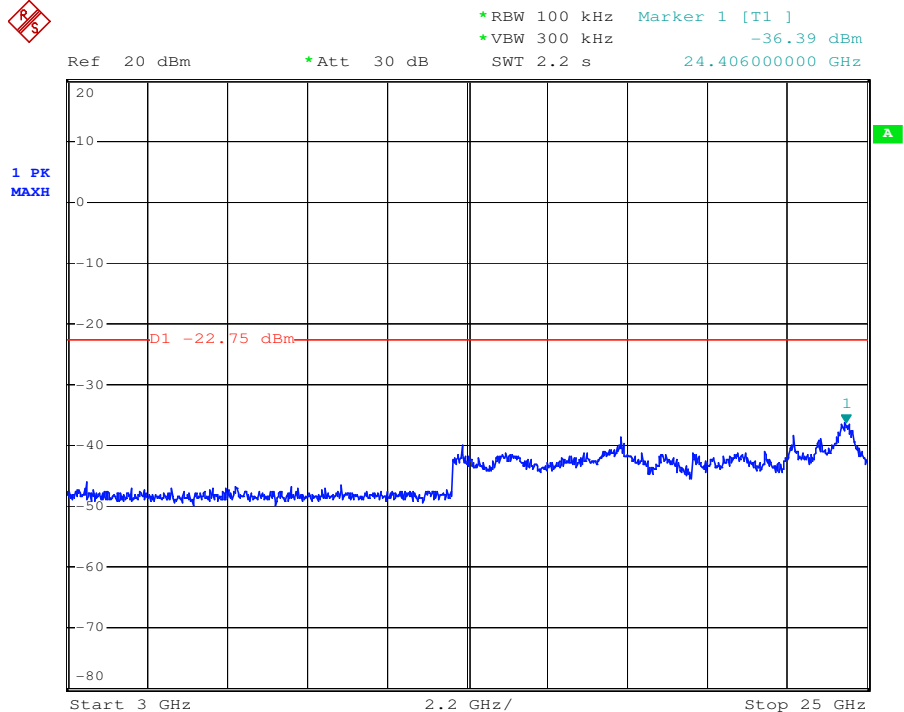

Test mode:	802.11g	Channel:	Lowest
-------------------	----------------	-----------------	---------------

30MHz-3GHz:



1 PK
MAXH

Ref 20 dBm *Att 30 dB *RBW 100 kHz Marker 1 [T1] -4.08 dBm
*VBW 300 kHz 2.417880000 GHz
SWT 300 ms

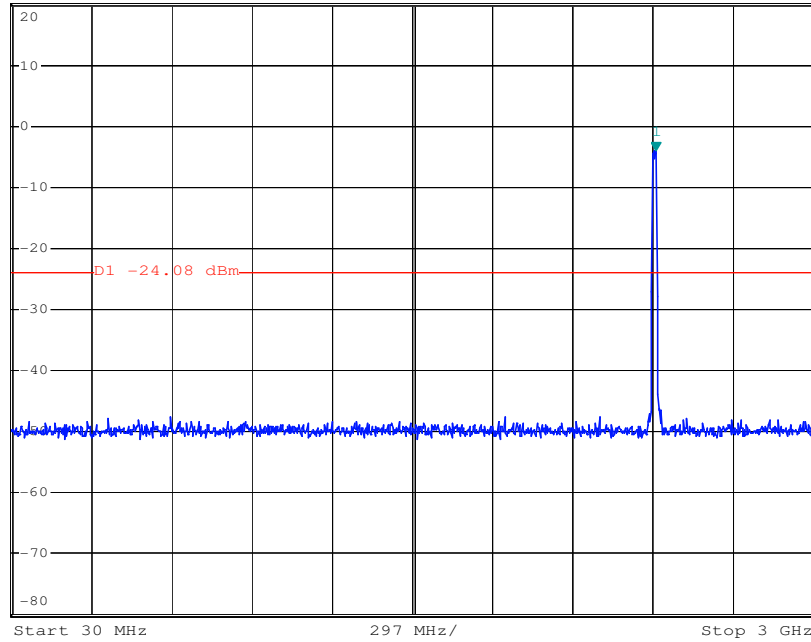

3GHz-25GHz:



1 PK
MAXH

Ref 20 dBm *Att 30 dB *RBW 100 kHz Marker 1 [T1] -36.31 dBm
*VBW 300 kHz 24.560000000 GHz
SWT 2.2 s

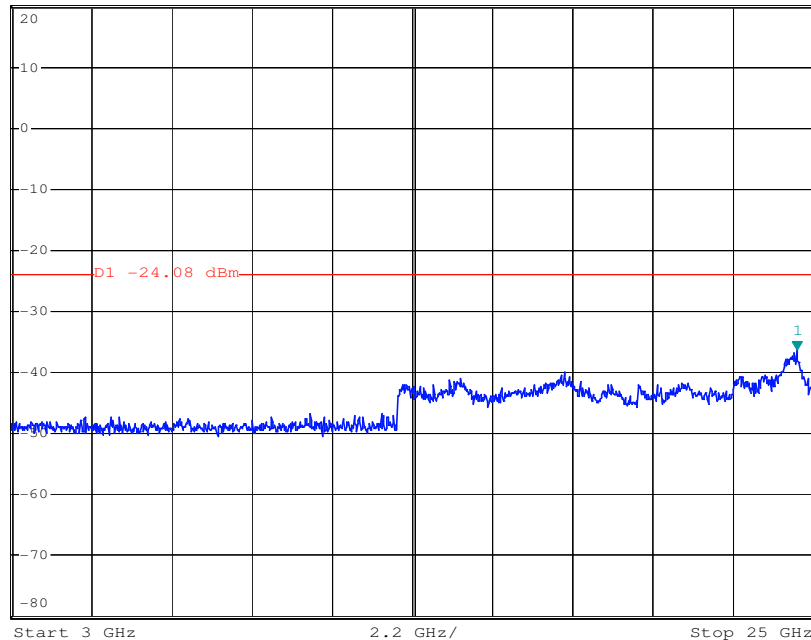

Test mode:	802.11g	Channel:	Middle
-------------------	----------------	-----------------	---------------

30MHz-3GHz:



Ref 20 dBm * Att 30 dB * RBW 100 kHz Marker 1 [T1]
 * VBW 300 kHz -3.43 dBm
 SWT 300 ms 2.438670000 GHz

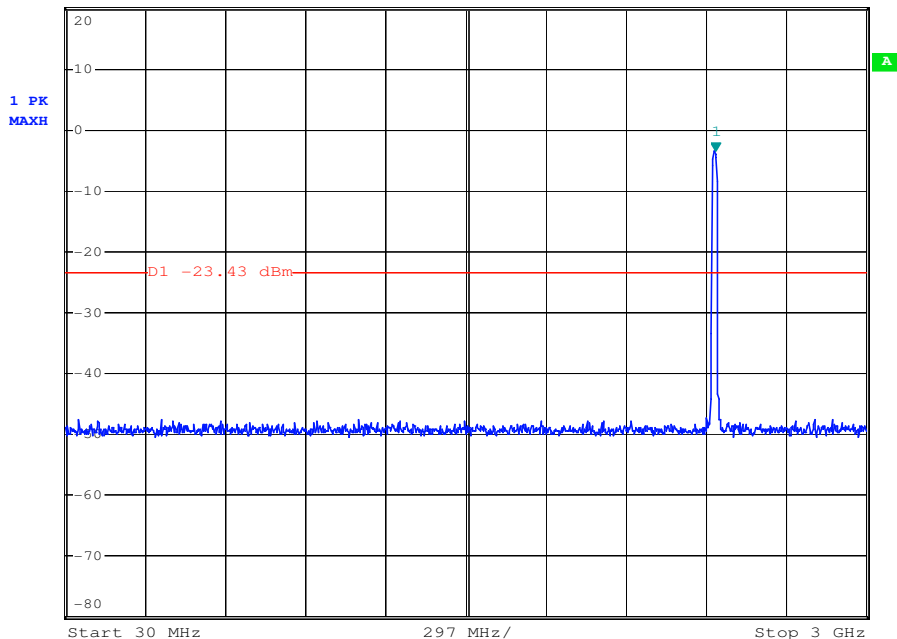

3GHz-25GHz:



Ref 20 dBm * Att 30 dB * RBW 100 kHz Marker 1 [T1]
 * VBW 300 kHz -36.53 dBm
 SWT 2.2 s 24.450000000 GHz

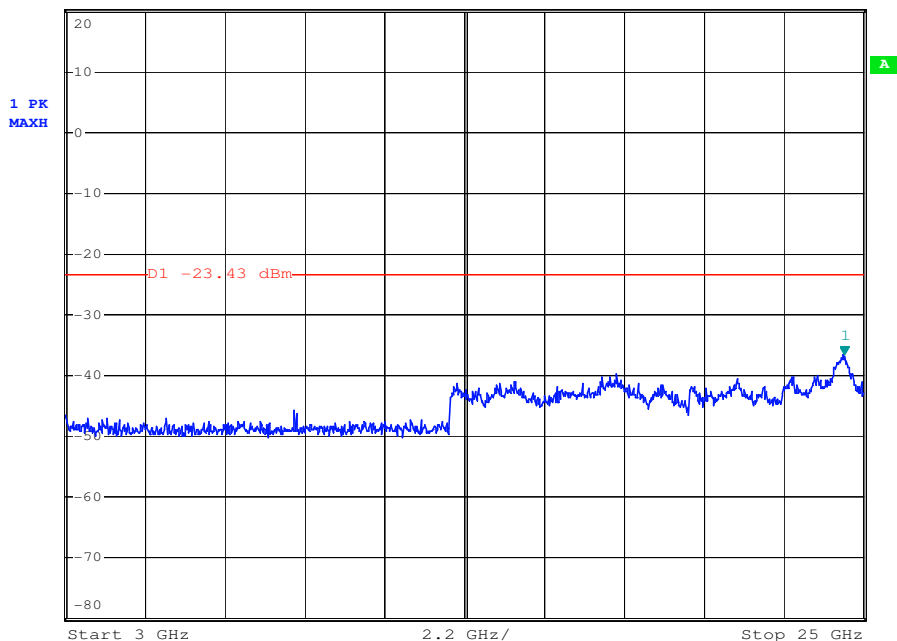

Test mode:	802.11g	Channel:	Highest
-------------------	----------------	-----------------	----------------

30MHz-3GHz:

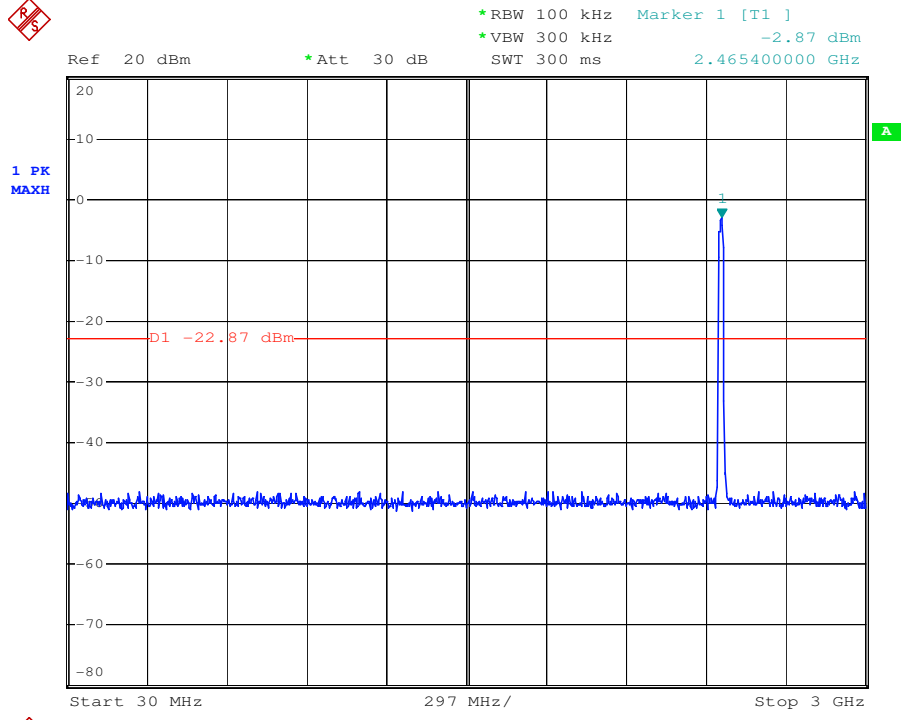

3GHz-25GHz:

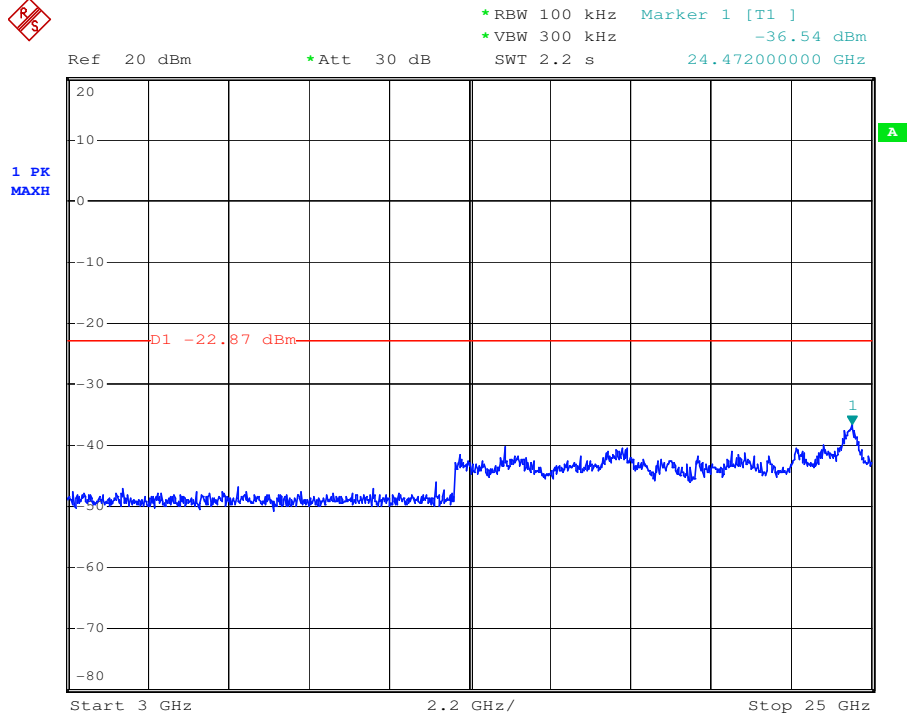

Test mode:	802.11n20	Channel:	Lowest
-------------------	------------------	-----------------	---------------

30MHz-3GHz:



1 PK
MAXH

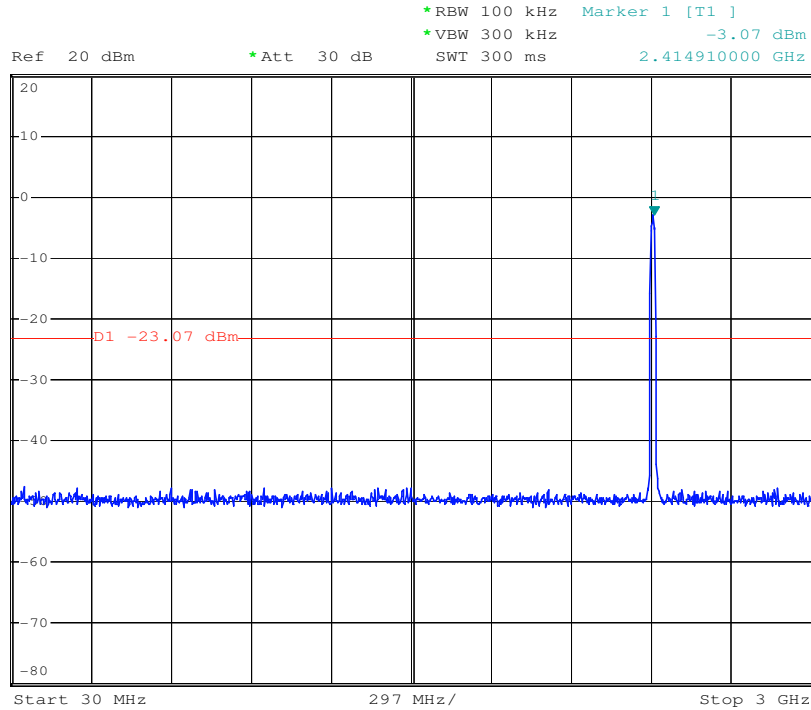

3GHz-25GHz:



1 PK
MAXH

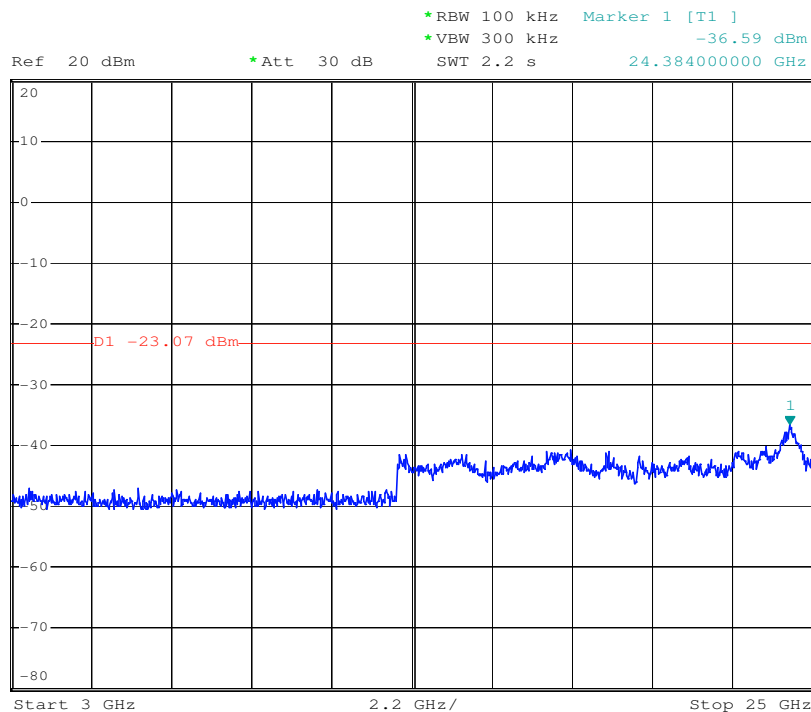

Test mode:	802.11n20	Channel:	Middle
-------------------	------------------	-----------------	---------------

30MHz-3GHz:

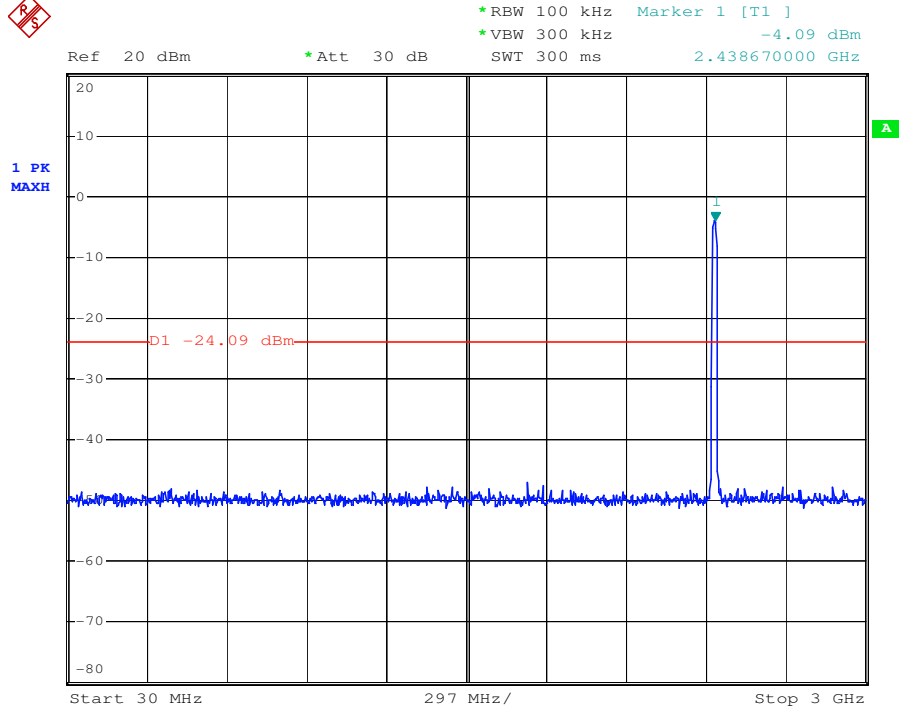

3GHz-25GHz:

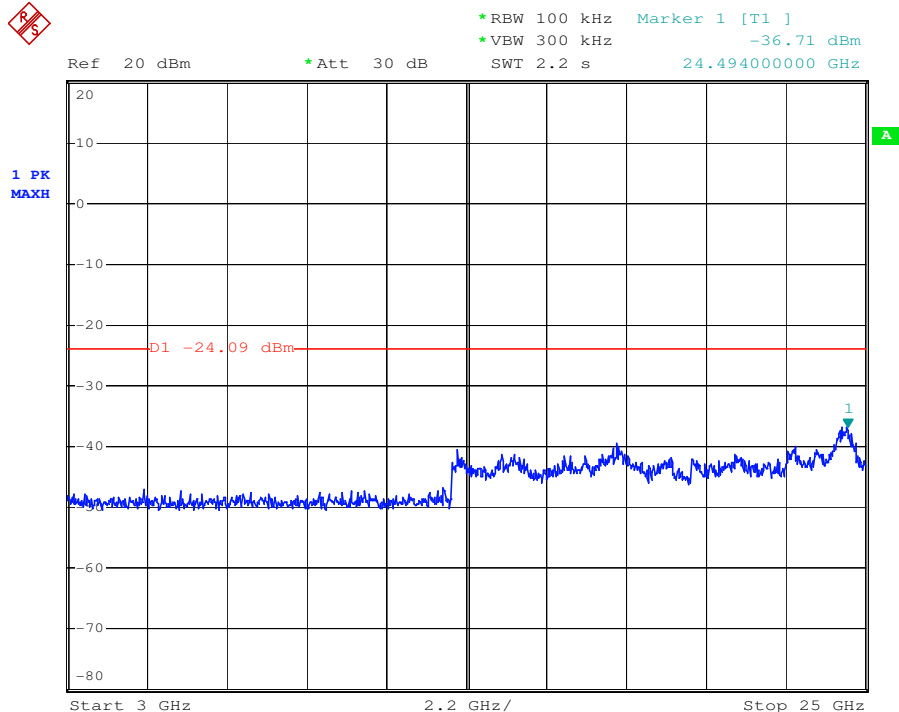

Test mode:	802.11n20	Channel:	Highest
-------------------	------------------	-----------------	----------------

30MHz-3GHz:

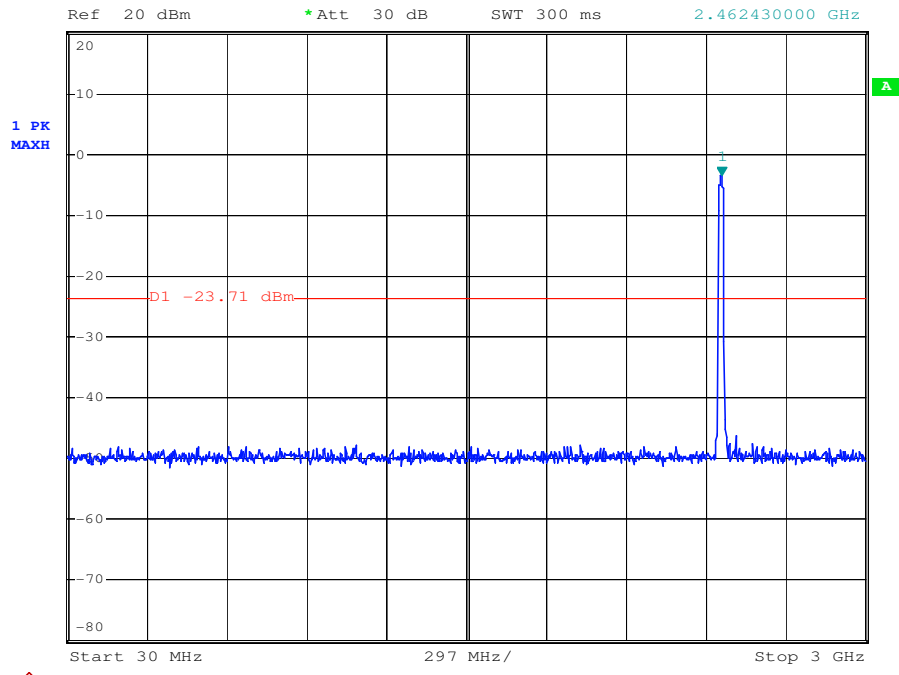

3GHz-25GHz:

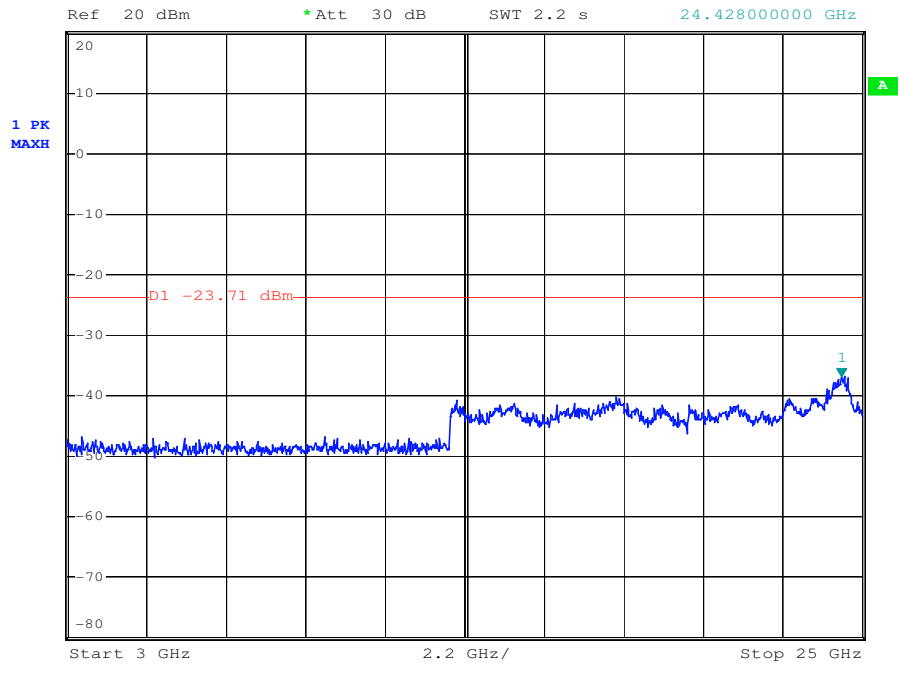

Test mode:	802.11n40	Channel:	Lowest
-------------------	------------------	-----------------	---------------

30MHz-3GHz:



1 PK
MAXH

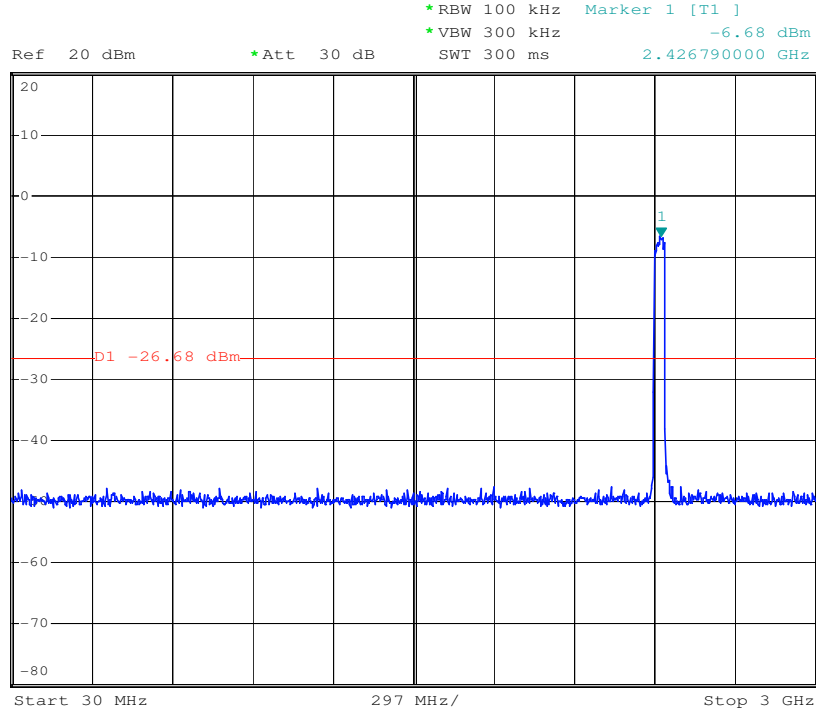

3GHz-25GHz:



1 PK
MAXH

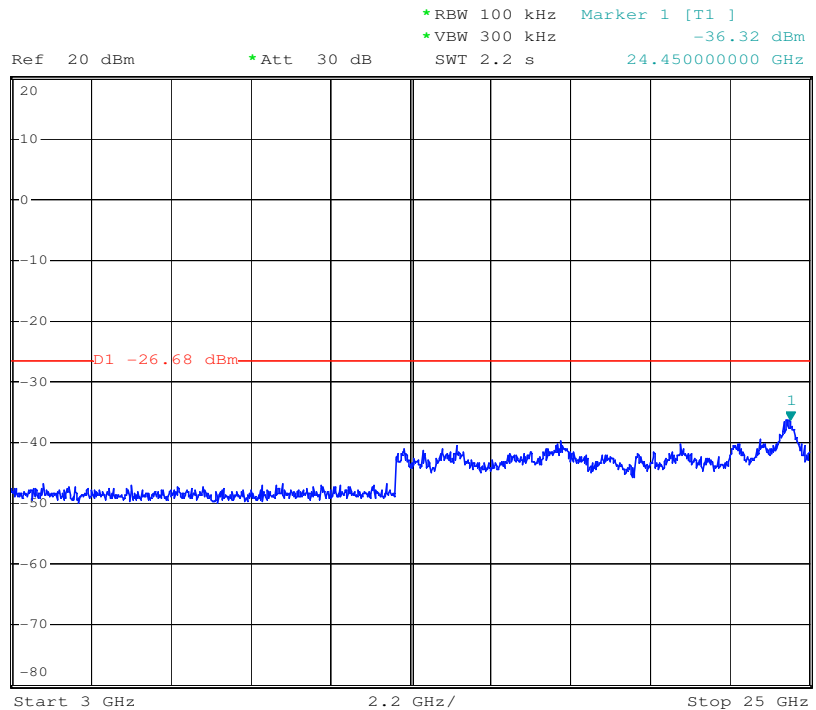

Test mode:	802.11n40	Channel:	Middle
-------------------	------------------	-----------------	---------------

30MHz-3GHz:



Ref 20 dBm *Att 30 dB *RBW 100 kHz Marker 1 [T1] -6.81 dBm
*VBW 300 kHz 2.441640000 GHz
SWT 300 ms

1 PK
MAXH

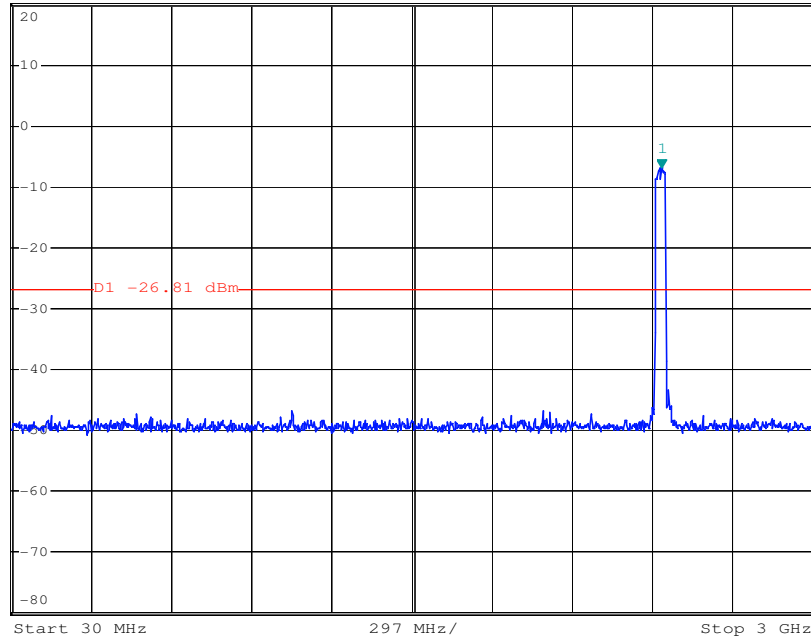

3GHz-25GHz:



Ref 20 dBm *Att 30 dB *RBW 100 kHz Marker 1 [T1] -36.97 dBm
*VBW 300 kHz 24.362000000 GHz
SWT 2.2 s

1 PK
MAXH

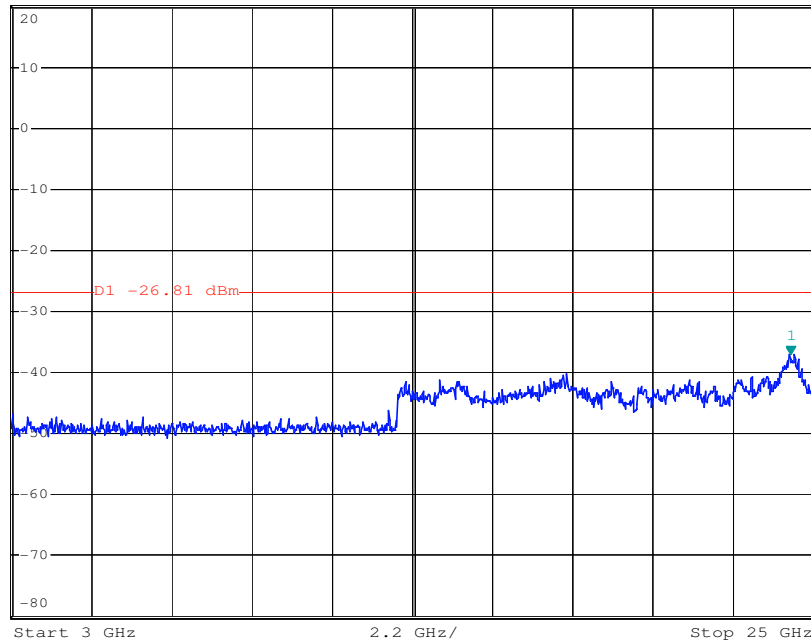

Test mode:	802.11n40	Channel:	Highest
-------------------	------------------	-----------------	----------------

30MHz-3GHz:



1 PK
MAXH

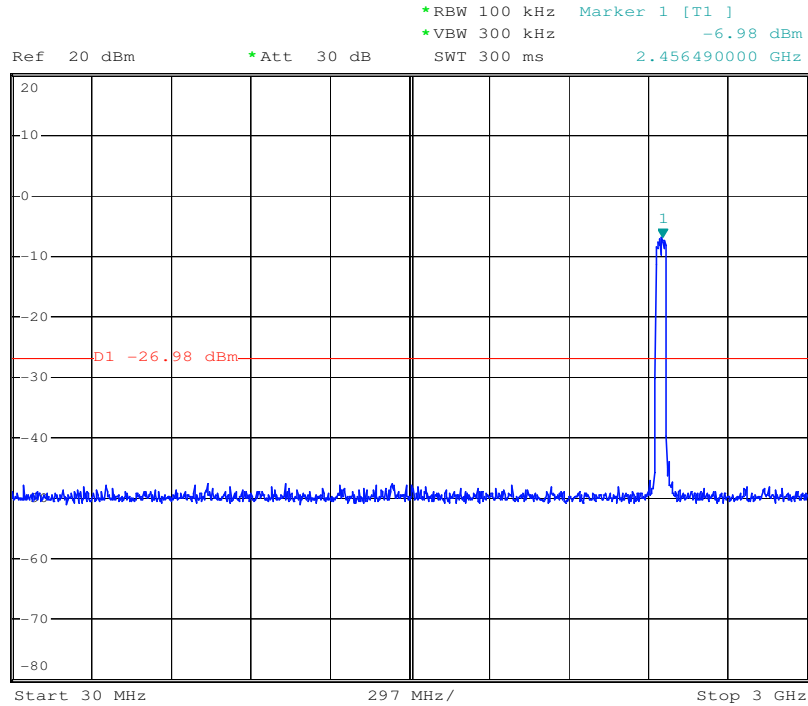

3GHz-25GHz:



1 PK
MAXH

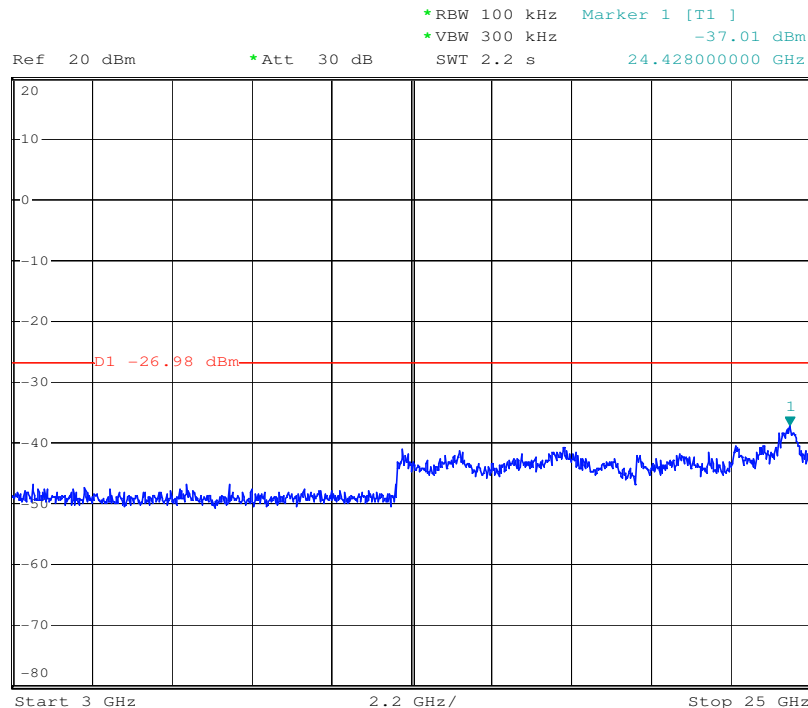

7.7.2 Conducted Band-edge

Test plot as follows:

Test mode:	802.11b	Channel:	Lowest
-------------------	----------------	-----------------	---------------

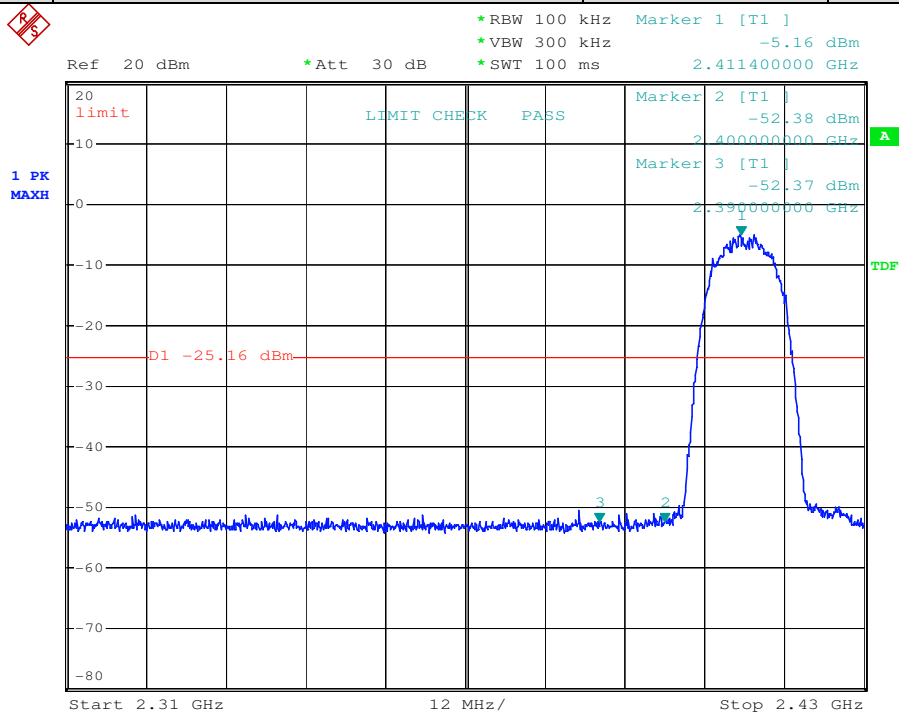

Test mode:	802.11b	Channel:	Highest
-------------------	----------------	-----------------	----------------

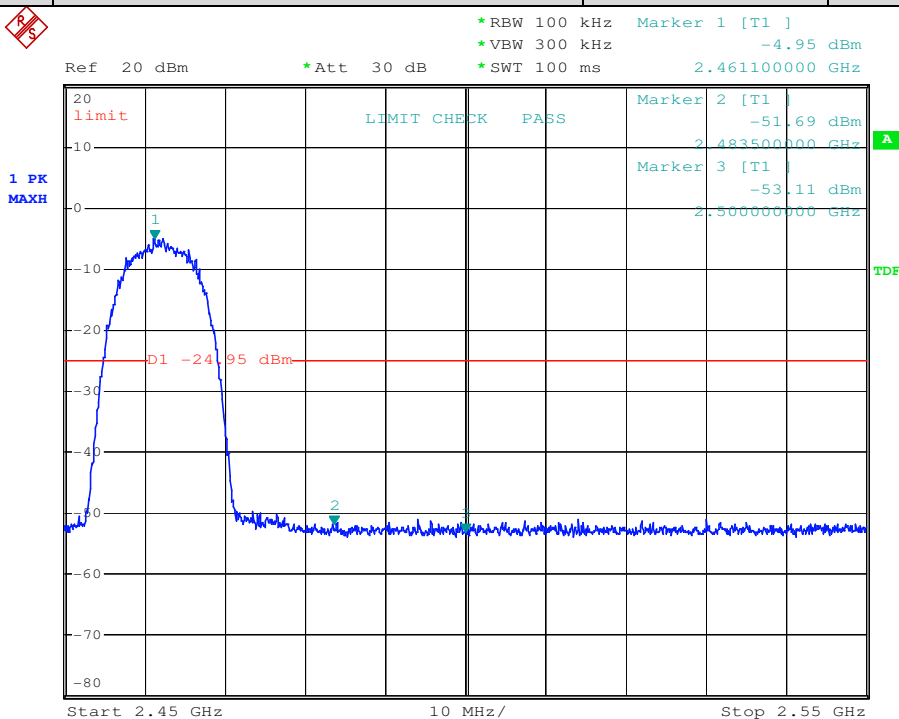

This document is issued by the Company subject to its General Conditions of Service printed overleaf, available on request or accessible at www.sgs.com/terms_and_conditions.htm and, for electronic format documents, subject to Terms and Conditions for Electronic Documents at www.sgs.com/terms_e-document.htm. Attention is drawn to the limitation of liability, indemnification and jurisdiction issues defined therein. Any holder of this document is advised that information contained hereon reflects the Company's findings at the time of its intervention only and within the limits of Client's instructions, if any. The Company's sole responsibility is to its Client and this document does not exonerate parties to a transaction from exercising all their rights and obligations under the transaction documents. This document cannot be reproduced except in full, without prior written approval of the Company. Any unauthorized alteration, forgery or falsification of the content or appearance of this document is unlawful and offenders may be prosecuted to the fullest extent of the law. Unless otherwise stated the results shown in this test report refer only to the sample(s) tested and such sample(s) are retained for 90 days only



Test mode:	802.11g	Channel:	Lowest
------------	---------	----------	--------



1 PK
MAXH

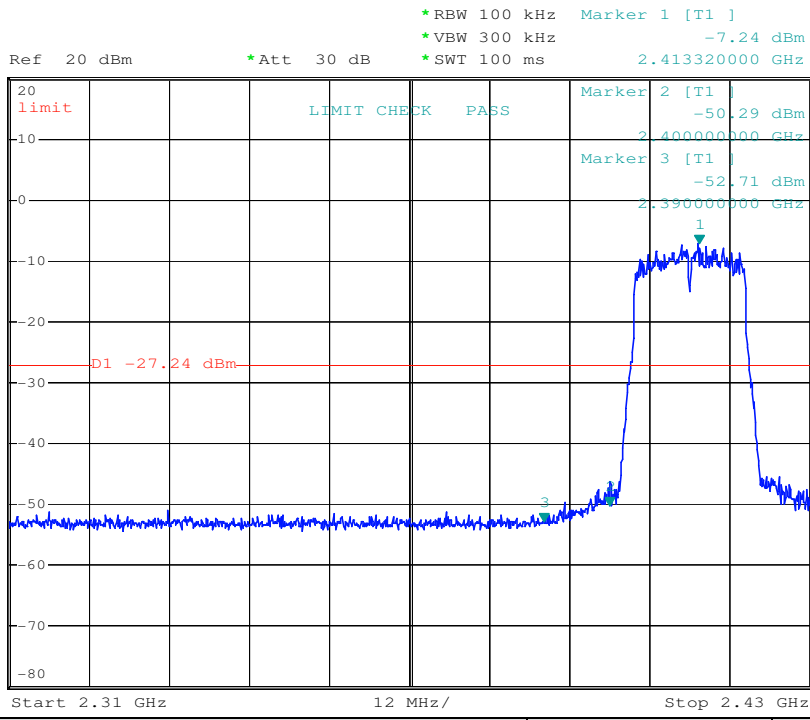

Test mode:	802.11g	Channel:	Highest
------------	---------	----------	---------



1 PK
MAXH

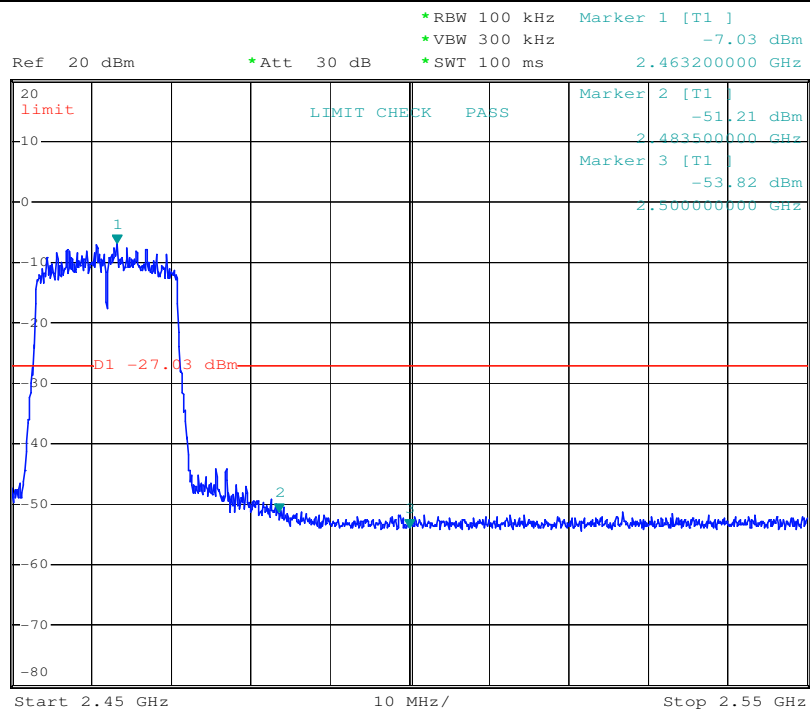



Test mode:	802.11n20	Channel:	Lowest
------------	-----------	----------	--------

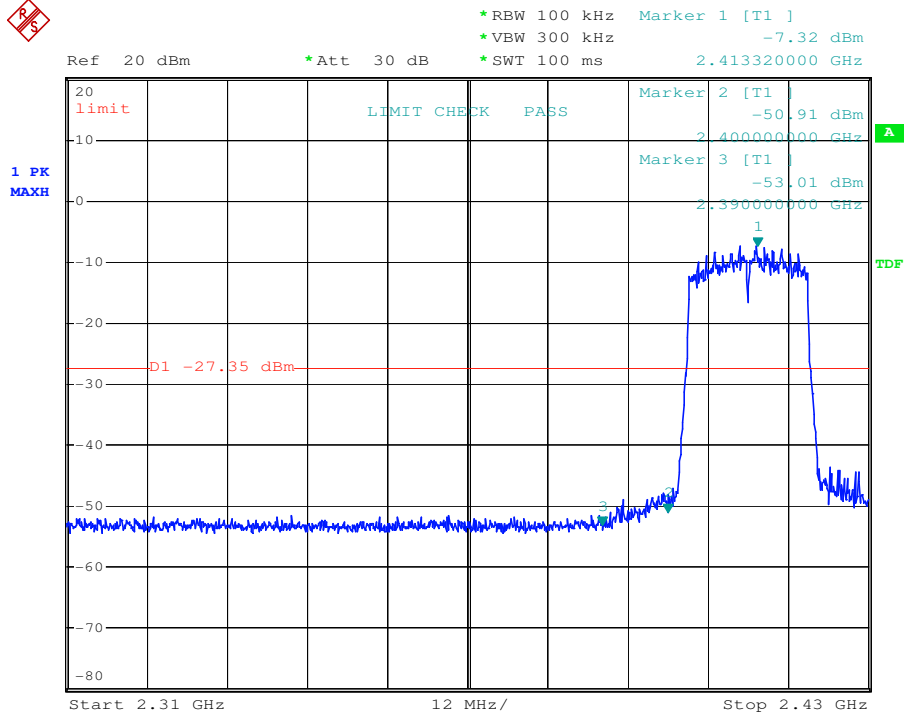

Test mode:	802.11n20	Channel:	Highest
------------	-----------	----------	---------

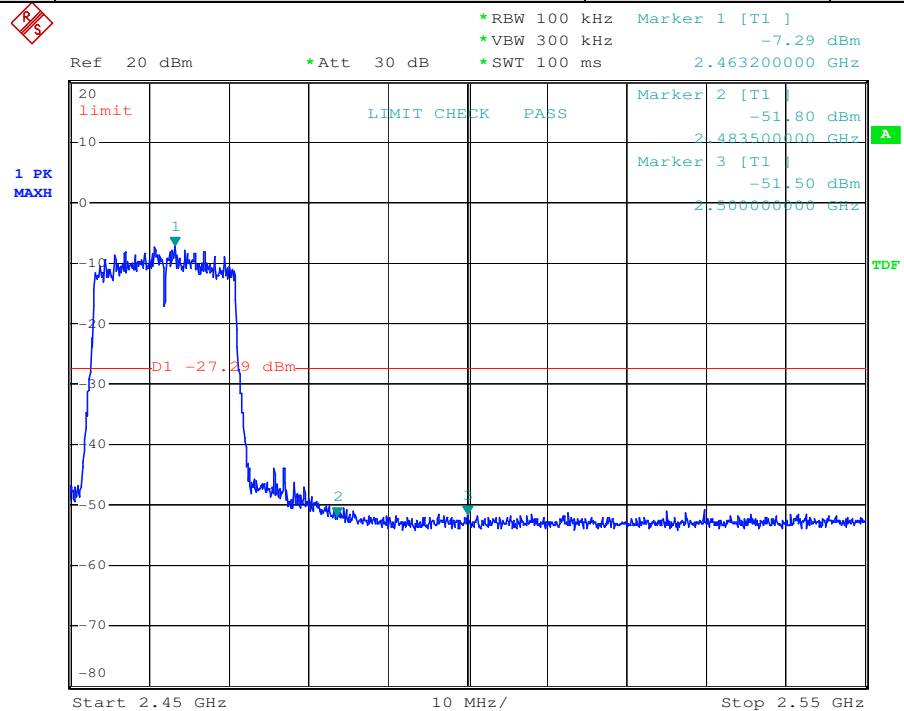

Test mode:	802.11n40	Channel:	Lowest
-------------------	------------------	-----------------	---------------



*RBW 100 kHz Marker 1 [T1]
 *VBW 300 kHz -10.43 dBm
 *SWT 100 ms 2.425830000 GHz
 Ref 20 dBm *Att 30 dB

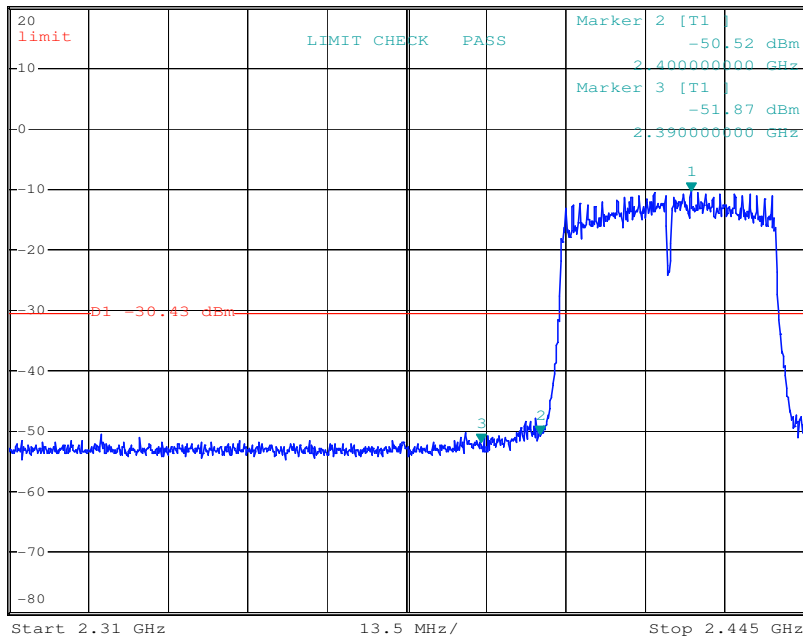

Test mode:	802.11n40	Channel:	Highest
-------------------	------------------	-----------------	----------------



*RBW 100 kHz Marker 1 [T1]
 *VBW 300 kHz -10.39 dBm
 *SWT 100 ms 2.449440000 GHz
 Ref 20 dBm *Att 30 dB

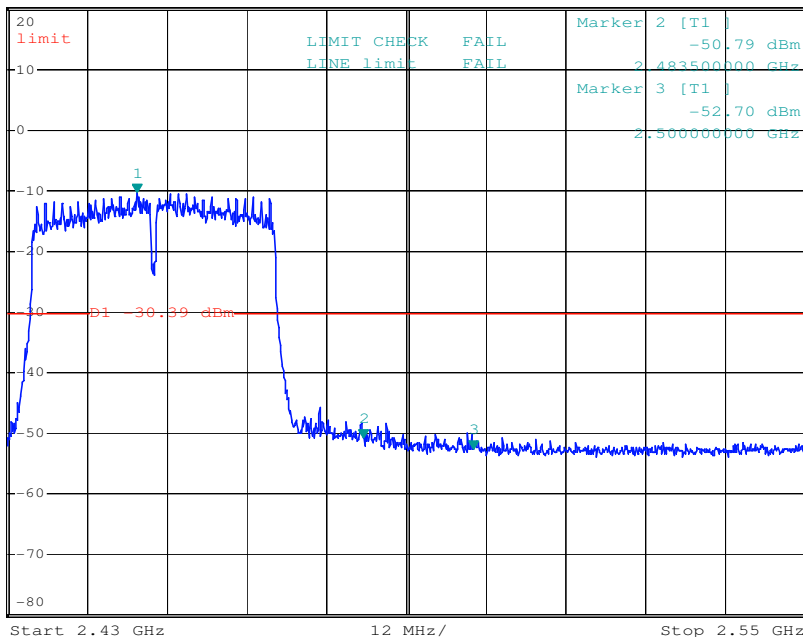

7.8 Radiated Spurious Emissions and Band-edge

Frequency Range: 9KHz to 25GHz

Test site/setup: Measurement Distance: 3m (Semi-Anechoic Chamber)
Test instrumentation set-up:

Frequency Range	Detector	RBW	VBW
0.009MHz-0.090MHz	Peak	10kHz	30kHz
0.009MHz-0.090MHz	Average	10kHz	30kHz
0.090MHz-0.110MHz	Quasi-peak	10kHz	30kHz
0.110MHz-0.490MHz	Peak	10kHz	30kHz
0.110MHz-0.490MHz	Average	10kHz	30kHz
0.490MHz -30MHz	Quasi-peak	10kHz	30kHz
30MHz-1GHz	Quasi-peak	100kHz	300kHz
Above 1GHz	Peak	RBW=1MHz	VBW≥RBW
	Average		VBW=10Hz

Sweep=Auto

15.209 Limit:

Frequency	Limit (dBuV/m)
0.009MHz-0.490MHz	128.5 ~ 93.8
0.490MHz-1.705MHz	73.8 ~63.0
1.705MHz-30MHz	69.5
30MHz-88MHz	40.0
88MHz-216MHz	43.5
216MHz-960MHz	46.0
960MHz-1GHz	54.0
Above 1GHz	54.0

Note: 15.35(b), Unless otherwise specified, the limit on peak radio frequency emissions is 20dB above the maximum permitted average emission limit applicable to the equipment under test. This peak limit applies to the total peak emission level radiated by the device.

Test Configuration:

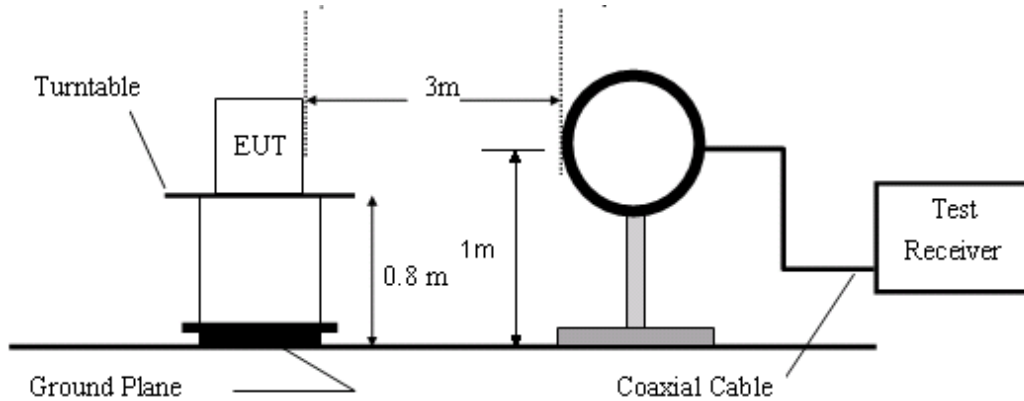

Figure1. Below 30MHz radiated emissions test configuration

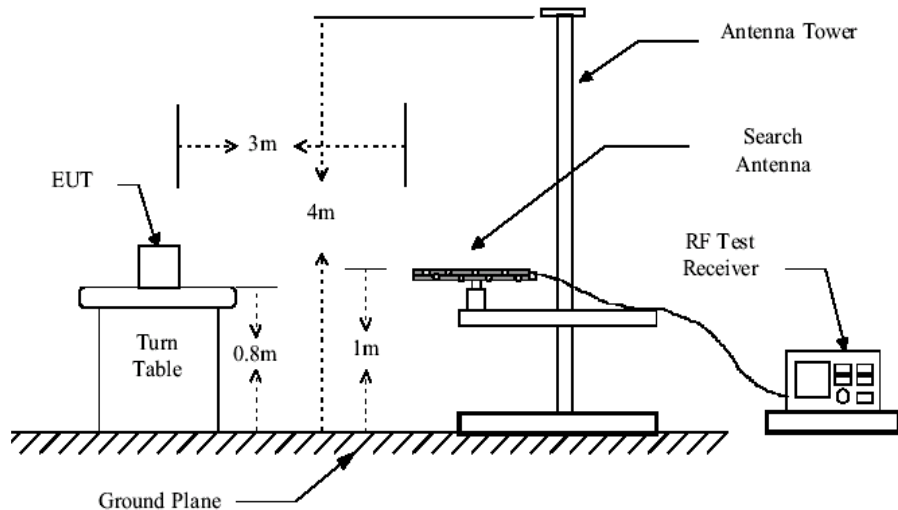

Figure2. 30MHz to 1GHz radiated emissions test configuration

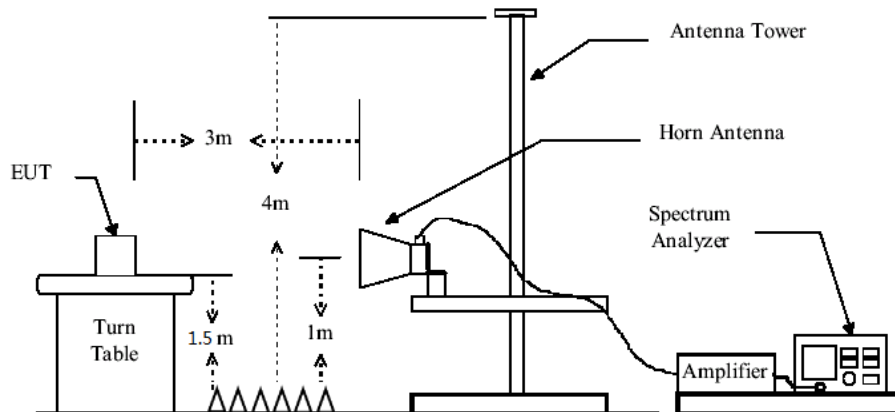

Figure3. Above 1GHz radiated emissions test configuration

- Test Procedure:**
- 1) The procedure used was ANSI Standard C63.10 The receiver was scanned from 9KHz to 25GHz. When an emission was found, the table was rotated to produce the maximum signal strength. An initial pre-scan was performed for in peak detection mode using the receiver. The EUT was measured for both the Horizontal and Vertical polarities and performed a pre-test three orthogonal planes. For intentional radiators, measurements of the variation of the input power or the radiated signal level of the fundamental frequency component of the emission, as appropriate, shall be performed with the supply voltage varied between 85% and 115% of the nominal rated supply voltage. The worst case emissions were reported.
 - 2) Low noise amplifier was used below 1GHz, High pass Filter was used above 3GHz.
 - a) Between 1G and 3GHz, we did not use any amplifier or filter.
 - b) Pre-test was performed on Antenna A and Antenna B mode, Compliance test was performed on worse case (Antenna A mode).
 - 3) Test were performed for their spatial orthogonal(X, Y, Z), the worst test data (X orthogonal) was submitted.
 - a) For this intentional radiator operates below 25 GHz. the spectrum shall be investigated to the tenth harmonic of the highest fundamental frequency. And above the third harmonic of this intentional radiator, the disturbance is very low. So the test result only displays to 5rd harmonic.
 - b) As shown in Section, for frequencies above 1000MHz. the above field strength limits are based on average limits. However, the peak field strength of any emission shall not exceed the maximum permitted average limits specified above by more than 20 dB under any condition of modulation.
 - 4) Pretest under all modes below 1GHz; choose the worst case mode (802.11b) record on the report.
 - 5) The test only perform the EUT in transmitting status since the test frequencies were over 1GHz only required transmitting status.

Test Result: Pass

7.8.1 Radiated Spurious Emissions

30MHz-1GHz:

Lowest Channel

Item	Freq.	Read Level	Antenna Factor	Pream p Factor	Cable Loss	Result Level	Limit Line	Over Limit	Detector	Polarization
(Mark)	(MHz)	(dBμV)	(dB/m)	(dB)	(dB)	(dBμV/m)	(dBμV/m)	(dB)		
1	40.988	21.49	13.10	23.70	0.27	11.16	40.00	-28.84	QP	Horizontal
2	43.353	21.81	13.10	23.70	0.31	11.52	40.00	-28.48	QP	Horizontal
3	51.843	21.94	12.48	23.69	0.43	11.16	40.00	-28.84	QP	Horizontal
4	145.861	21.93	12.07	23.64	1.16	11.52	43.50	-31.98	QP	Horizontal
5	160.909	22.22	12.29	23.63	1.22	12.10	43.50	-31.40	QP	Horizontal
6	459.114	21.67	16.14	23.72	2.33	16.42	46.00	-29.58	QP	Horizontal
1	36.637	22.27	12.77	23.71	0.22	11.55	40.00	-28.45	QP	Vertical
2	39.024	21.91	13.01	23.71	0.25	11.46	40.00	-28.54	QP	Vertical
3	51.481	21.82	12.51	23.69	0.43	11.07	40.00	-28.93	QP	Vertical
4	141.826	22.05	11.81	23.64	1.13	11.35	43.50	-32.15	QP	Vertical
5	160.346	22.65	12.30	23.63	1.22	12.54	43.50	-30.96	QP	Vertical
6	174.424	22.84	12.16	23.63	1.31	12.68	43.50	-30.82	QP	Vertical

Middle Channel

Item	Freq.	Read Level	Antenna Factor	Pream p Factor	Cable Loss	Result Level	Limit Line	Over Limit	Detector	Polarization
(Mark)	(MHz)	(dBμV)	(dB/m)	(dB)	(dB)	(dBμV/m)	(dBμV/m)	(dB)		
1	33.095	39.63	12.56	23.71	0.15	28.63	40.00	-11.37	QP	Horizontal
2	121.976	48.67	11.18	23.65	1.04	37.24	43.50	-6.26	QP	Horizontal
3	204.955	47.25	9.19	23.62	1.41	34.23	43.50	-9.27	QP	Horizontal
4	519.065	44.93	16.88	23.75	2.48	40.54	46.00	-5.46	QP	Horizontal
5	543.274	45.34	17.25	23.77	2.56	41.38	46.00	-4.62	QP	Horizontal
6	711.673	40.69	20.55	23.88	2.99	40.35	46.00	-5.65	QP	Horizontal
1	32.749	43.30	12.56	23.71	0.15	32.30	40.00	-7.70	QP	Vertical
2	264.746	39.35	10.79	23.65	1.66	28.15	46.00	-17.85	QP	Vertical
3	519.065	41.51	16.88	23.75	2.48	37.12	46.00	-8.88	QP	Vertical
4	663.473	43.38	19.88	23.85	2.87	42.28	46.00	-3.72	QP	Vertical
5	711.673	42.76	20.55	23.88	2.99	42.42	46.00	-3.58	QP	Vertical
6	734.491	42.71	20.95	23.89	3.06	42.83	46.00	-3.17	QP	Vertical

Highest Channel

Item	Freq.	Read Level	Antenna Factor	Preamp Factor	Cable Loss	Result Level	Limit Line	Over Limit	Detector	Polarization
(Mark)	(MHz)	(dBμV)	(dB/m)	(dB)	(dB)	(dBμV/m)	(dBμV/m)	(dB)		
1	32.864	39.83	12.56	23.71	0.15	28.83	40.00	-11.17	QP	Horizontal
2	122.404	48.60	11.17	23.65	1.04	37.16	43.50	-6.34	QP	Horizontal
3	144.335	43.79	11.96	23.64	1.16	33.27	43.50	-10.23	QP	Horizontal
4	264.746	46.30	10.79	23.65	1.66	35.10	46.00	-10.90	QP	Horizontal
5	519.065	45.54	16.88	23.75	2.48	41.15	46.00	-4.85	QP	Horizontal
6	663.473	42.30	19.88	23.85	2.87	41.20	46.00	-4.80	QP	Horizontal
1	33.562	38.13	12.57	23.71	0.16	27.15	40.00	-12.85	QP	Vertical
2	207.123	39.87	9.15	23.62	1.43	26.83	43.50	-16.67	QP	Vertical
3	361.714	37.58	13.65	23.69	2.01	29.55	46.00	-16.45	QP	Vertical
4	494.198	44.20	16.20	23.73	2.42	39.09	46.00	-6.91	QP	Vertical
5	663.473	43.40	19.88	23.85	2.87	42.30	46.00	-3.70	QP	Vertical
6	734.491	42.44	20.95	23.89	3.06	42.56	46.00	-3.44	QP	Vertical

Result Level = Read Level + Antenna Factor + Cable loss - Preamp Factor

Below is the plot of worst case on Lowest channel:
Vertical:

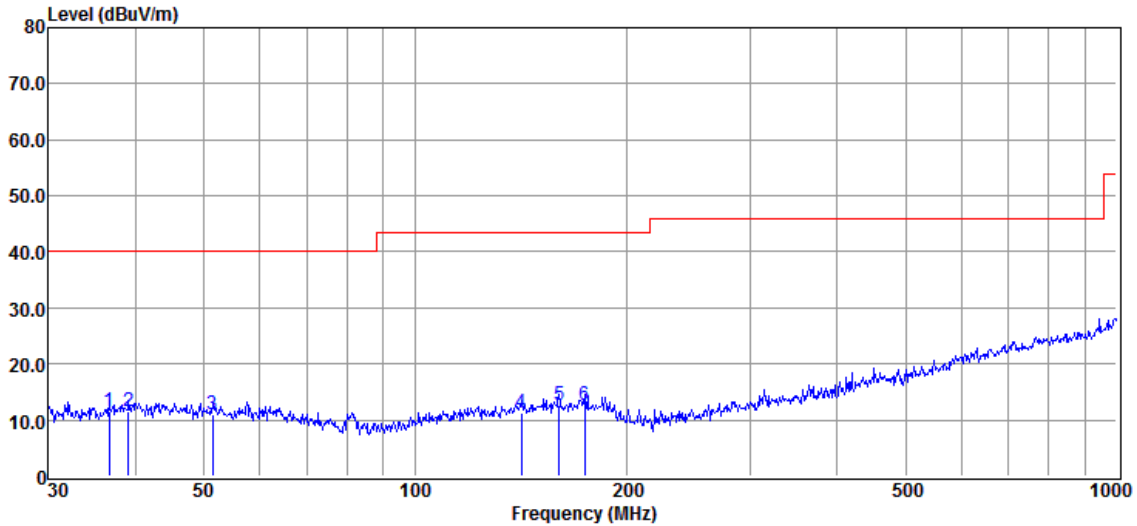

Horizontal:

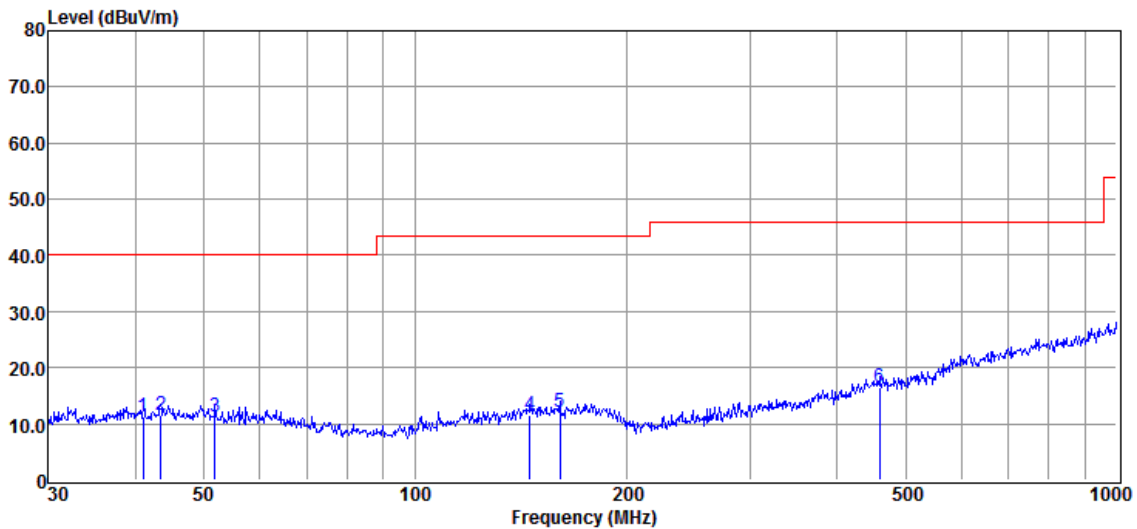

Above 1GHz:

Test mode: 802.11b

Channel: Lowest

Mark	Frequency (MHz)	Reading (dBuV)	Factor (dB)	Emission (dBuV/m)	Limit (dBuV/m)	Over Limit (dB)	Detector	Polarization
1	4824	45.20	6.34	51.54	54	-2.46	peak	Horizontal
2	7236	40.11	10.76	50.87	54	-3.13	peak	Horizontal
3	9648	35.68	14.37	50.05	54	-3.95	peak	Horizontal
4	4824	41.39	6.40	47.79	54	-6.21	peak	Vertical
5	7236	41.71	10.76	52.47	54	-1.53	peak	Vertical
6	9648	38.42	14.37	52.79	54	-1.21	peak	Vertical

Test mode: 802.11b

Channel: Middle

Mark	Frequency (MHz)	Reading (dBuV)	Factor (dB)	Emission (dBuV/m)	Limit (dBuV/m)	Over Limit (dB)	Detector	Polarization
1	4874	36.43	7.02	43.45	54	-10.55	peak	Horizontal
2	7311	40.57	11.15	51.72	54	-2.28	peak	Horizontal
3	9748	37.21	14.36	51.57	54	-2.43	peak	Horizontal
4	4874	38.37	7.02	45.39	54	-8.61	peak	Vertical
5	7311	40.83	11.15	51.98	54	-2.02	peak	Vertical
6	9748	38.56	14.36	52.92	54	-1.08	peak	Vertical

Test mode: 802.11b

Channel: Highest

Mark	Frequency (MHz)	Reading (dBuV)	Factor (dB)	Emission (dBuV/m)	Limit (dBuV/m)	Over Limit (dB)	Detector	Polarization
1	4924	40.02	7.41	47.43	54	-6.57	peak	Horizontal
2	7386	38.55	11.54	50.09	54	-3.91	peak	Horizontal
3	9848	36.01	14.39	50.40	54	-3.60	peak	Horizontal
4	4924	41.92	7.41	49.33	54	-4.67	peak	Vertical
5	7386	38.97	11.54	50.51	54	-3.49	peak	Vertical
6	9848	37.72	14.39	52.11	54	-1.89	peak	Vertical

Test mode: 802.11g

Channel: Lowest

Mark	Frequency (MHz)	Reading (dBuV)	Factor (dB)	Emission (dBuV/m)	Limit (dBuV/m)	Over Limit (dB)	Detector	Polarization
1	4824	44.61	5.74	50.35	54	-3.65	peak	Horizontal
2	7236	43.03	9.66	52.69	54	-1.31	peak	Horizontal
3	9648	40.12	13.5	53.62	54	-0.38	peak	Horizontal
4	4824	43.34	5.74	49.08	54	-4.92	peak	Vertical
5	7236	42.21	9.66	51.87	54	-2.13	peak	Vertical
6	9648	40.42	13.5	53.92	54	-0.08	peak	Vertical

Test mode: 802.11g

Channel: Middle

Mark	Frequency (MHz)	Reading (dBuV)	Factor (dB)	Emission (dBuV/m)	Limit (dBuV/m)	Over Limit (dB)	Detector	Polarization
1	4874	42.85	6.17	49.02	54	-4.98	peak	Horizontal
2	7311	43.26	9.76	53.02	54	-0.98	peak	Horizontal
3	9748	40.03	13.53	53.56	54	-0.44	peak	Horizontal
4	4874	42.17	6.17	48.34	54	-5.66	peak	Vertical
5	7311	42.84	9.76	52.60	54	-1.40	peak	Vertical
6	9748	40.03	13.53	53.56	54	-0.44	peak	Vertical

Test mode: 802.11g

Channel: Highest

Mark	Frequency (MHz)	Reading (dBuV)	Factor (dB)	Emission (dBuV/m)	Limit (dBuV/m)	Over Limit (dB)	Detector	Polarization
1	4924	44.03	6.21	50.24	54	-3.76	peak	Horizontal
2	7386	42.64	9.93	52.57	54	-1.43	peak	Horizontal
3	9848	39.15	13.57	52.72	54	-1.28	peak	Horizontal
4	4924.5	43.75	6.21	49.96	54	-4.04	peak	Vertical
5	7386	43.42	9.93	53.35	54	-0.65	peak	Vertical
6	9848	40.11	13.57	53.68	54	-0.32	peak	Vertical

Test mode: 802.11n20

Channel: Lowest

Mark	Frequency (MHz)	Reading (dBuV)	Factor (dB)	Emission (dBuV/m)	Limit (dBuV/m)	Over Limit (dB)	Detector	Polarization
1	4824	40.25	6.40	46.65	54	-7.35	peak	Horizontal
2	7236	39.71	10.76	50.47	54	-3.53	peak	Horizontal
3	9648	35.94	14.37	50.31	54	-3.69	peak	Horizontal
4	4824	33.25	6.40	39.65	54	-14.35	peak	Vertical
5	7236	31.99	10.76	42.75	54	-11.25	peak	Vertical
6	9648	31.29	14.37	45.66	54	-8.34	peak	Vertical

Test mode: 802.11n20

Channel: Middle

Mark	Frequency (MHz)	Reading (dBuV)	Factor (dB)	Emission (dBuV/m)	Limit (dBuV/m)	Over Limit (dB)	Detector	Polarization
1	4874	40.59	6.92	47.51	54	-6.49	peak	Horizontal
2	7311	41.81	11.08	52.89	54	-1.11	peak	Horizontal
3	9748	36.81	14.36	51.17	54	-2.83	peak	Horizontal
4	4874	32.90	6.92	39.82	54	-14.18	peak	Vertical
5	7311	33.74	11.08	44.82	54	-9.18	peak	Vertical
6	9748	32.35	14.36	46.71	54	-7.29	peak	Vertical

Test mode: 802.11n20

Channel: Highest

Mark	Frequency (MHz)	Reading (dBuV)	Factor (dB)	Emission (dBuV/m)	Limit (dBuV/m)	Over Limit (dB)	Detector	Polarization
1	4924	41.68	7.31	48.99	54	-5.01	peak	Horizontal
2	7386	40.30	11.41	51.71	54	-2.29	peak	Horizontal
3	9848	36.18	14.38	50.56	54	-3.44	peak	Horizontal
4	4924	33.29	7.31	40.60	54	-13.40	peak	Vertical
5	7386	34.04	11.41	45.45	54	-8.55	peak	Vertical
6	9848	32.39	14.38	46.77	54	-7.23	peak	Vertical

Test mode: 802.11n40

Channel: Lowest

Mark	Frequency (MHz)	Reading (dBuV)	Factor (dB)	Emission (dBuV/m)	Limit (dBuV/m)	Over Limit (dB)	Detector	Polarization
1	4844	40.30	6.60	46.90	54	-7.10	peak	Horizontal
2	7266	38.66	10.89	49.55	54	-4.45	peak	Horizontal
3	9688	34.67	14.35	49.02	54	-4.98	peak	Horizontal
4	4844	33.01	6.60	39.61	54	-14.39	peak	Vertical
5	7266	33.13	10.89	44.02	54	-9.98	peak	Vertical
6	9688	32.80	14.35	47.15	54	-6.85	peak	Vertical

Test mode: 802.11n40

Channel: Middle

Mark	Frequency (MHz)	Reading (dBuV)	Factor (dB)	Emission (dBuV/m)	Limit (dBuV/m)	Over Limit (dB)	Detector	Polarization
1	4874	36.59	6.92	43.51	54	-10.49	peak	Horizontal
2	7311	37.98	11.08	49.06	54	-4.94	peak	Horizontal
3	9748	35.91	14.36	50.27	54	-3.73	peak	Horizontal
4	4874	32.11	6.92	39.03	54	-14.97	peak	Vertical
5	7311	34.11	11.08	45.19	54	-8.81	peak	Vertical
6	9748	31.29	14.36	45.65	54	-8.35	peak	Vertical

Test mode: 802.11n40

Channel: Highest

Mark	Frequency (MHz)	Reading (dBuV)	Factor (dB)	Emission (dBuV/m)	Limit (dBuV/m)	Over Limit (dB)	Detector	Polarization
1	4904	37.98	7.22	45.20	54	-8.80	peak	Horizontal
2	7356	37.63	11.28	48.91	54	-5.09	peak	Horizontal
3	9808	35.36	14.37	49.73	54	-4.27	peak	Horizontal
4	4904	33.58	7.22	40.80	54	-13.20	peak	Vertical
5	7356	33.77	11.28	45.05	54	-8.95	peak	Vertical
6	9808	32.24	14.37	46.61	54	-7.39	peak	Vertical

- Remark: 1. Test Level =Receiver Reading + Antenna Factor + Cable Loss –Preamplifier Factor.
 2. No any other emissions level which are attenuated less than 20dB below the limit. According to 15.31(o), the amplitude of spurious emissions from intentional radiators and emissions from unintentional radiators which are attenuated more than 20 dB below the permissible value need not be reported unless specifically required elsewhere in this Part. Hence there no other emissions have been reported.
 3. If the Peak value below the AV Limit, the AV test doesn't perform for this submission.

7.8.2 Radiated Band edge

Test Mode: 802.11b

Channel: Lowest

MK.	Frequency (MHz)	Reading (dBuV/m)	Corrected factor(dB)	Result (dBuV/m)	Limit (dBuV/m)	Over Limit (dB)	Detector	Polarization
1	2390	47.65	-3.89	43.76	54	-10.24	Peak	Horizontal
2	2411.76	106.30	-3.93	102.37	54	48.37	Peak	Horizontal
1	2390	47.83	-3.89	43.94	54	-10.06	Peak	Vertical
2	2411.52	104.60	-3.93	100.67	54	46.67	Peak	Vertical

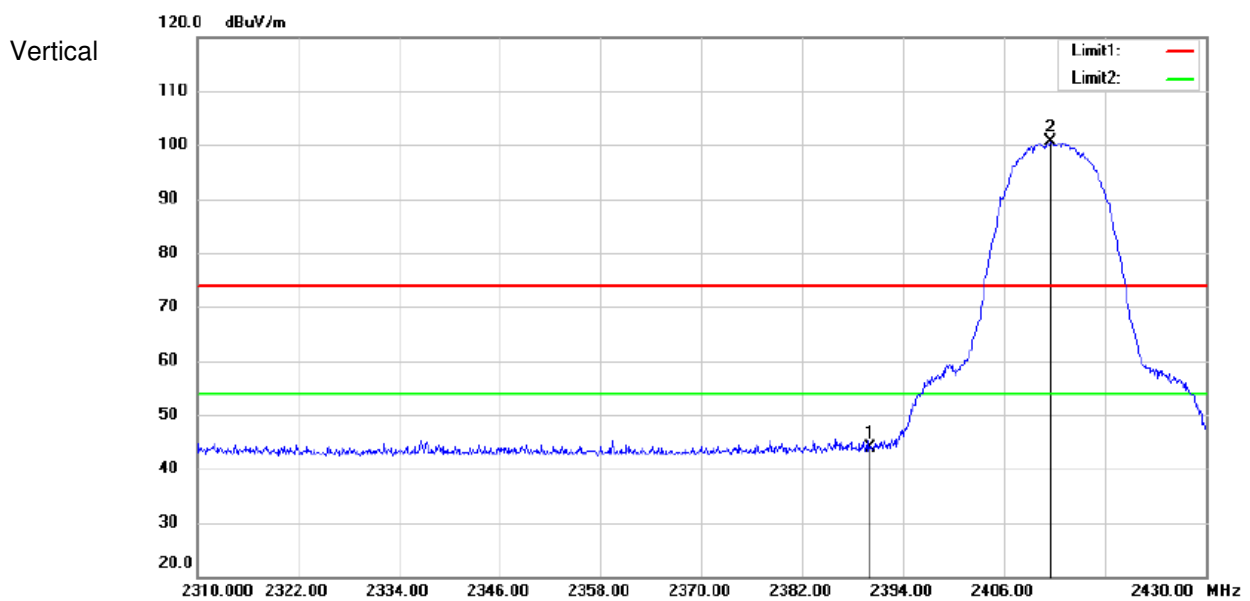
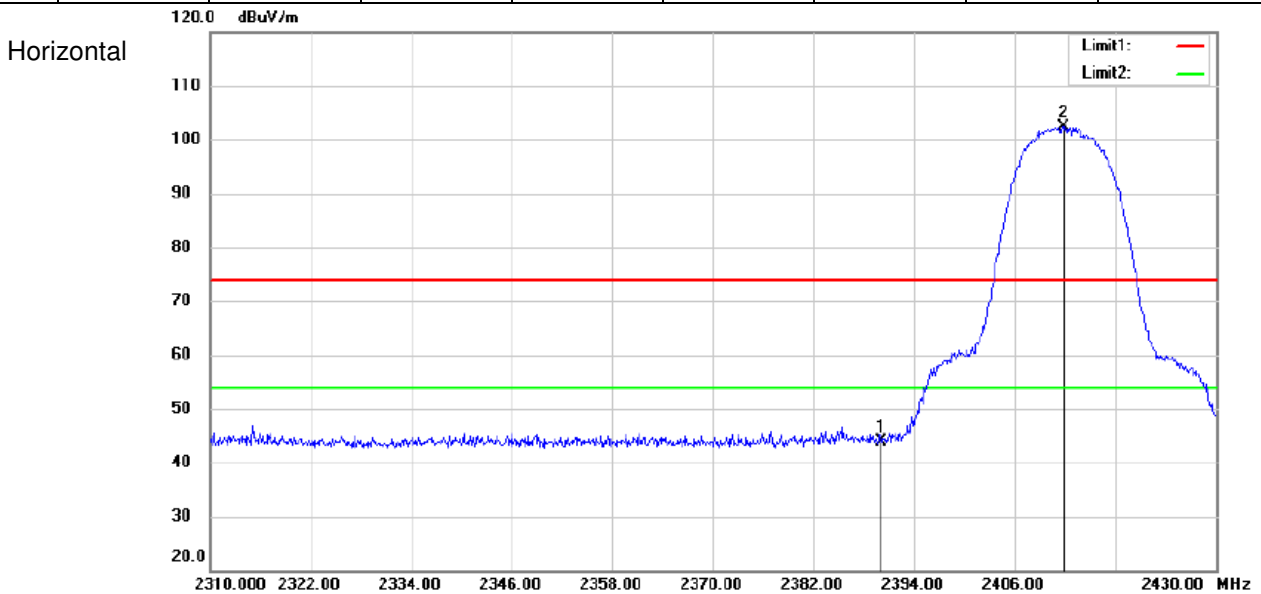

Test Mode: 802.11b

Channel: Highest

MK.	Frequency (MHz)	Reading (dBuV/m)	Corrected factor(dB)	Result (dBuV/m)	Limit (dBuV/m)	Over Limit (dB)	Detector	Polarization
1	2461.9	102.60	-3.99	98.61	54	44.61	Peak	Horizontal
2	2483.5	48.95	-4.01	44.94	54	-9.06	Peak	Horizontal
3	2500	46.73	-4.03	42.70	54	-11.30	Peak	Horizontal
1	2461.5	103.85	-3.99	99.86	54	45.86	Peak	Vertical
2	2483.5	49.80	-4.01	45.79	54	-8.21	Peak	Vertical
3	2500	46.63	-4.03	42.60	54	-11.40	Peak	Vertical

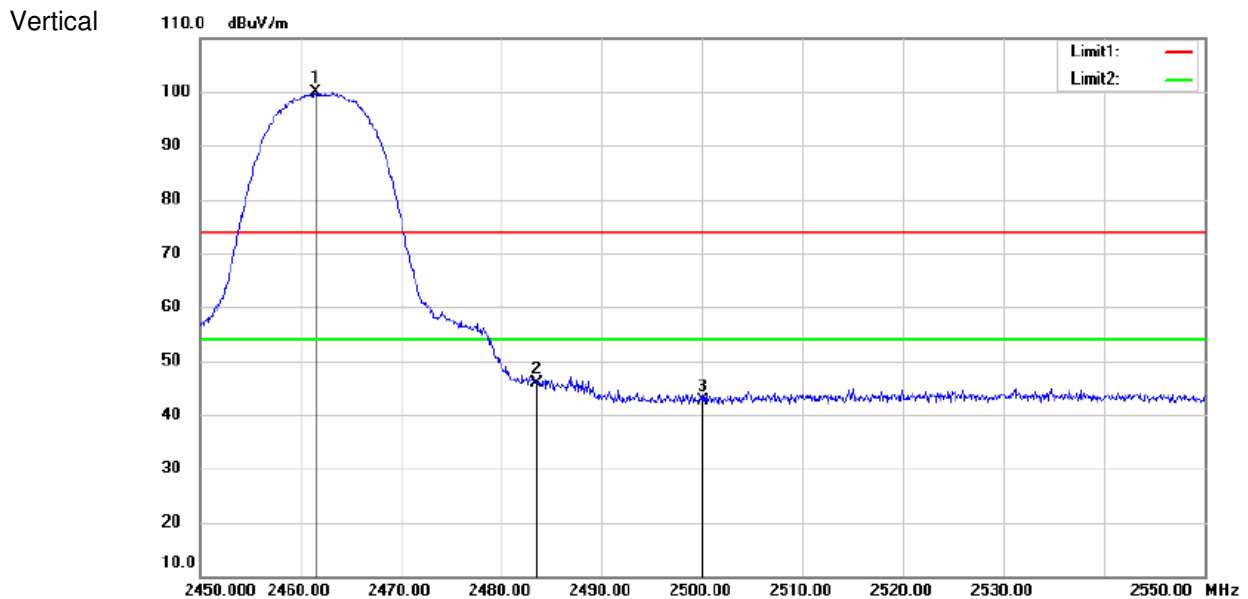
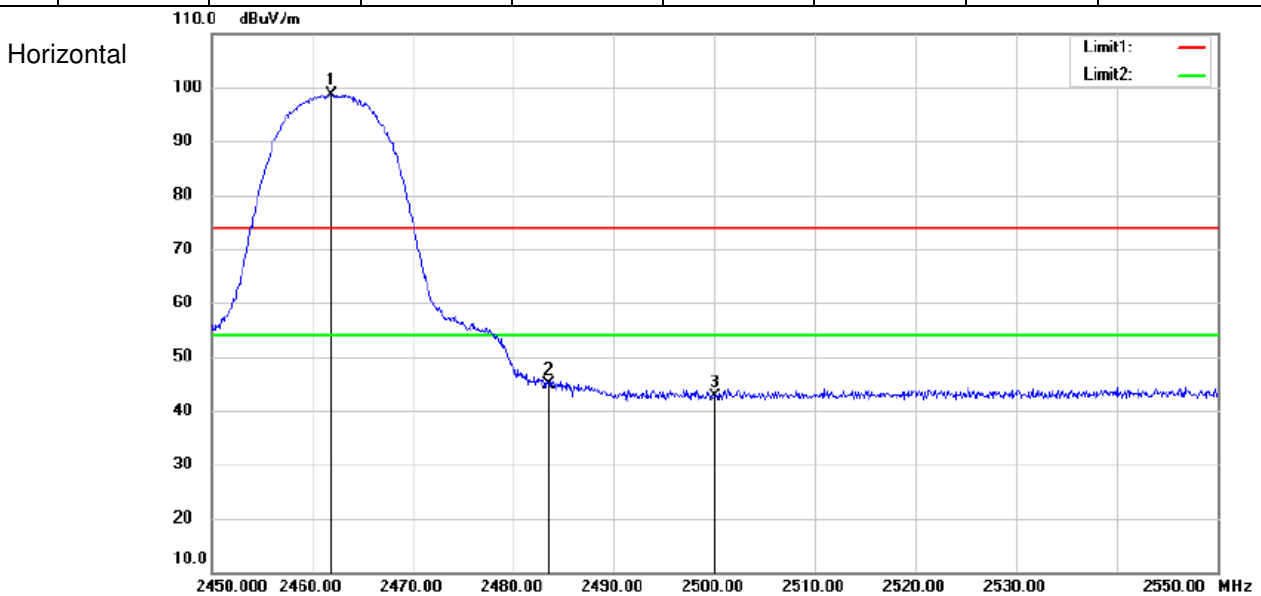

Test Mode: 802.11g

Channel: Lowest

MK.	Frequency (MHz)	Reading (dBuV/m)	Corrected factor(dB)	Result (dBuV/m)	Limit (dBuV/m)	Over Limit (dB)	Detector	Polarization
1	2390	65.65	-3.89	61.76	74	-12.24	Peak	Horizontal
2	2408.28	104.08	-3.93	100.15	74	26.15	Peak	Horizontal
1	2390	41.88	-3.89	37.99	54	-16.01	Average	Horizontal
2	2405.52	82.52	-3.93	78.59	54	24.59	Average	Horizontal

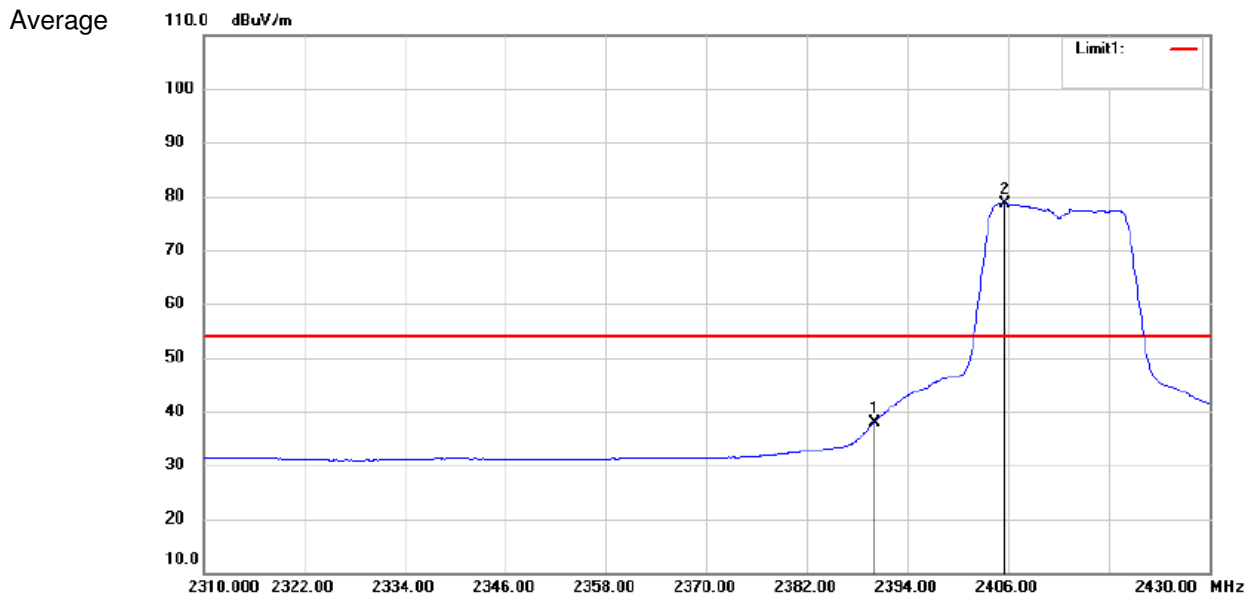
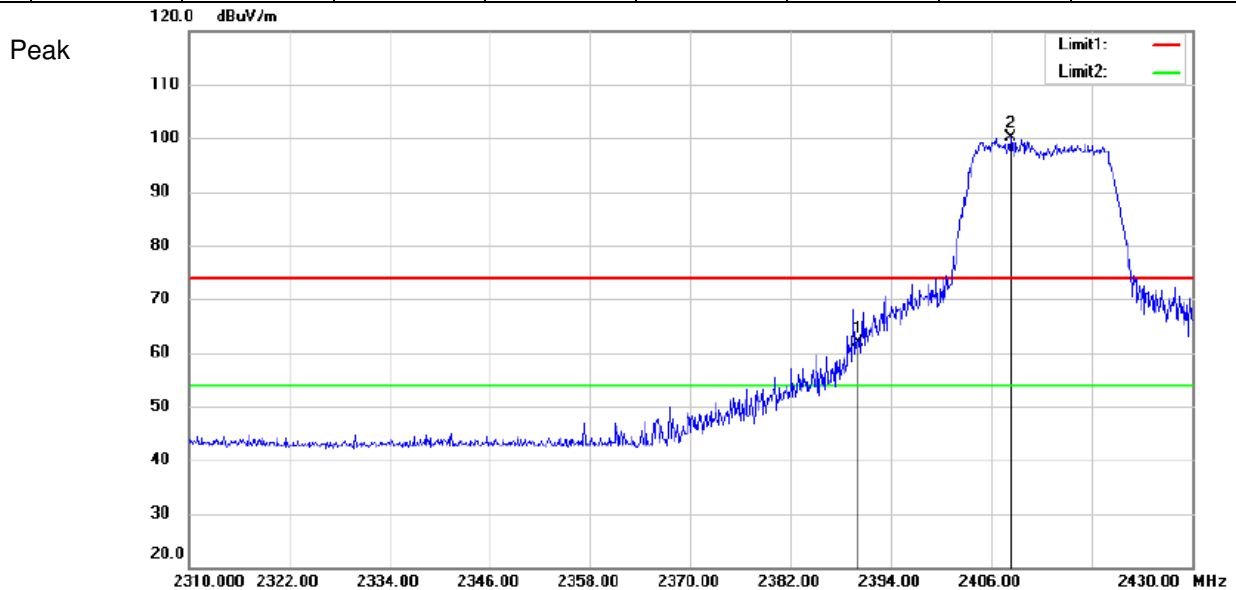

Test Mode: 802.11g

Channel: Lowest

MK.	Frequency (MHz)	Reading (dBuV/m)	Corrected factor(dB)	Result (dBuV/m)	Limit (dBuV/m)	Over Limit (dB)	Detector	Polarization
1	2390	66.62	-3.89	62.73	74	-11.27	Peak	Vertical
2	2404.56	102.78	-3.92	98.86	74	24.86	Peak	Vertical
1	2390	35.74	-3.89	31.85	54	-22.15	Average	Vertical
2	2410.8	73.94	-3.92	70.02	54	16.02	Average	Vertical

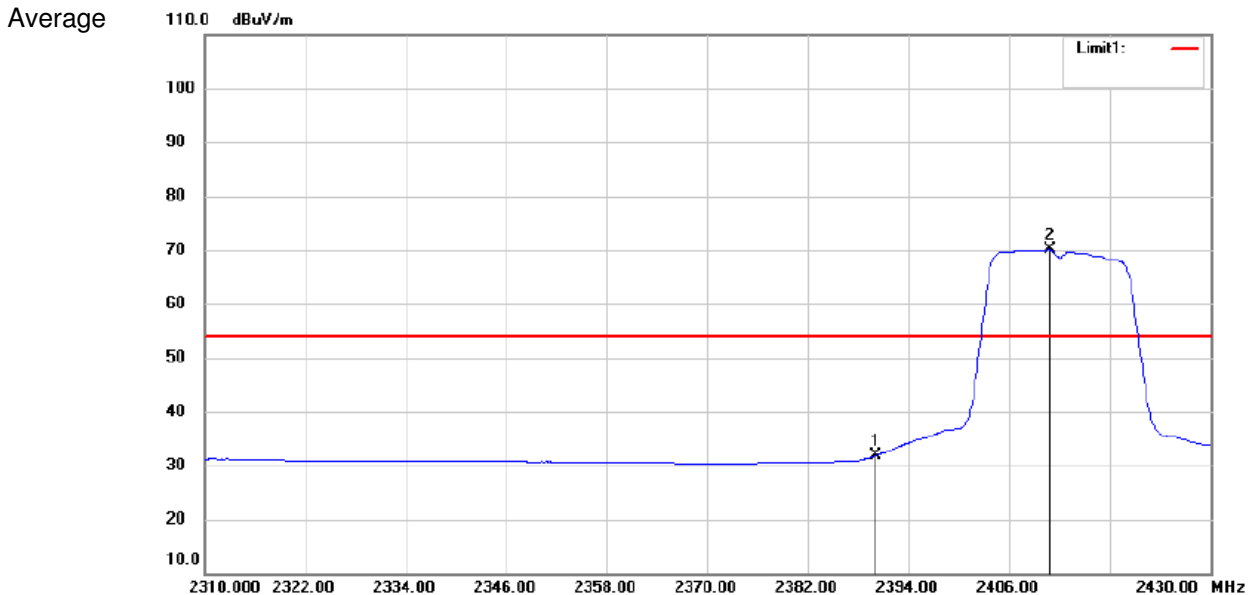
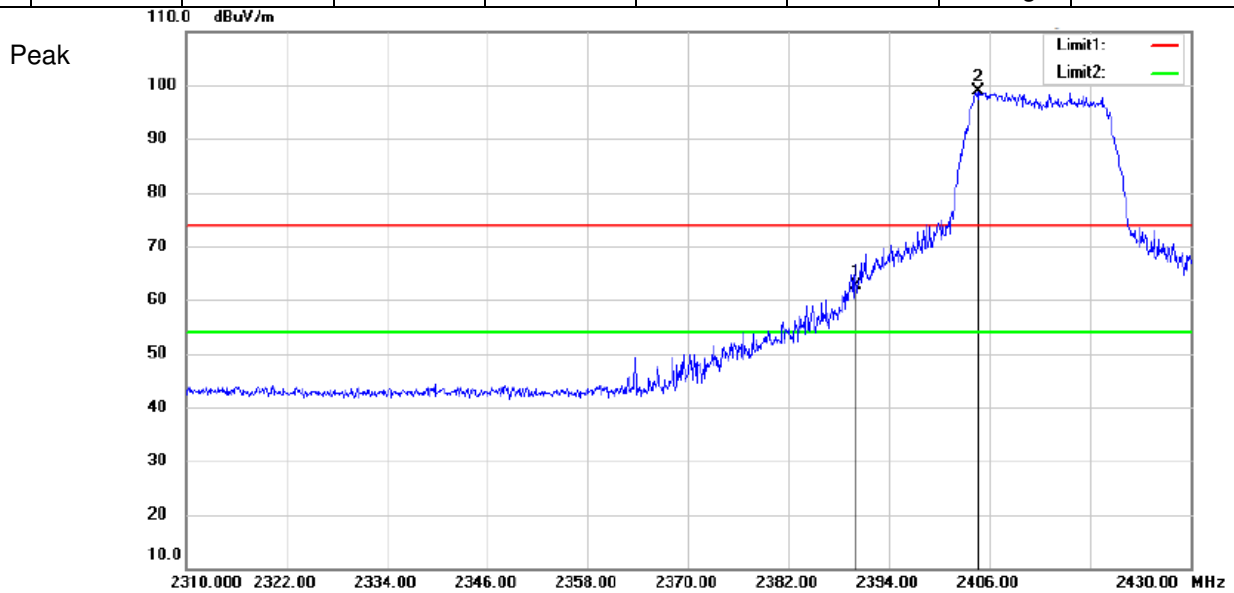

Test Mode: 802.11g

Channel: Highest

MK.	Frequency (MHz)	Reading (dBuV/m)	Corrected factor(dB)	Result (dBuV/m)	Limit (dBuV/m)	Over Limit (dB)	Detector	Polarization
1	2457.6	101.01	-3.98	97.03	74	23.03	Peak	Horizontal
2	2483.5	66.07	-4.01	62.06	74	-11.94	Peak	Horizontal
3	2500	59.77	-4.03	55.74	74	-18.26	Peak	Horizontal
1	2456.8	80.45	-3.98	76.47	54	22.47	Average	Horizontal
2	2483.5	42.93	-4.01	38.92	54	-15.08	Average	Horizontal
3	2500	35.9	-4.03	31.87	54	-22.13	Average	Horizontal

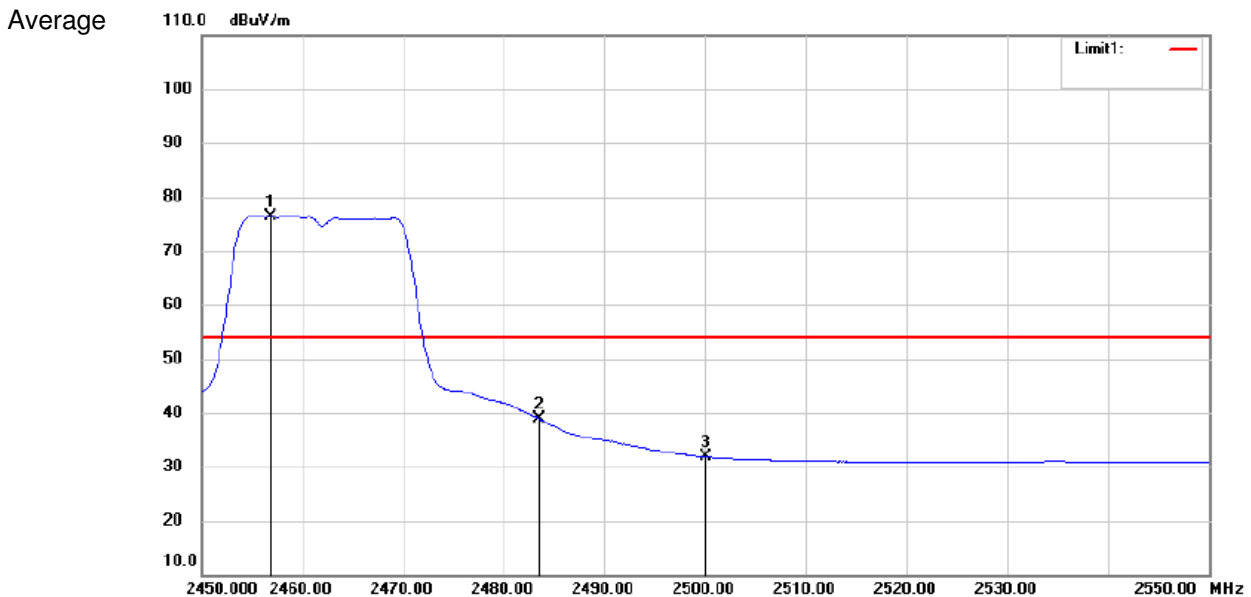
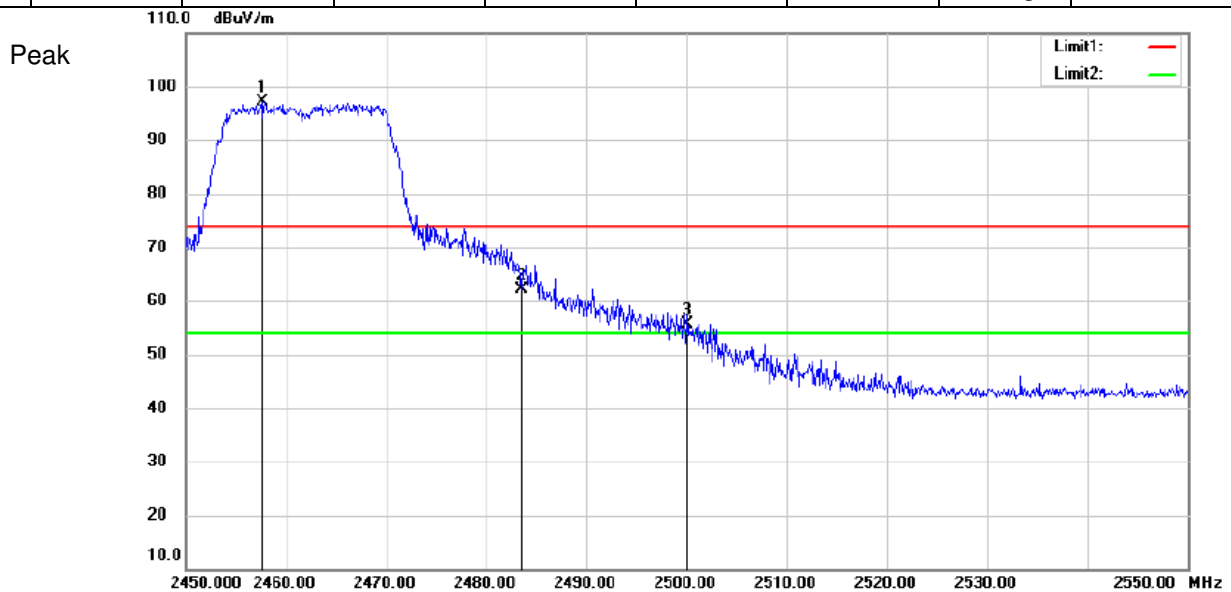

Test Mode: 802.11g

Channel: Highest

MK.	Frequency (MHz)	Reading (dBuV/m)	Corrected factor(dB)	Result (dBuV/m)	Limit (dBuV/m)	Over Limit (dB)	Detector	Polarization
1	2464.7	103.75	-3.99	99.76	74	25.76	Peak	Vertical
2	2483.5	71.04	-4.01	67.03	74	-6.97	Peak	Vertical
2	2500	61.99	-4.03	57.96	74	-16.04	Peak	Vertical
1	2466.9	82.43	-3.99	78.44	54	24.44	Average	Vertical
2	2483.5	44.07	-4.01	40.06	54	-13.94	Average	Vertical
3	2500	35.45	-4.03	31.42	54	-22.58	Average	Vertical

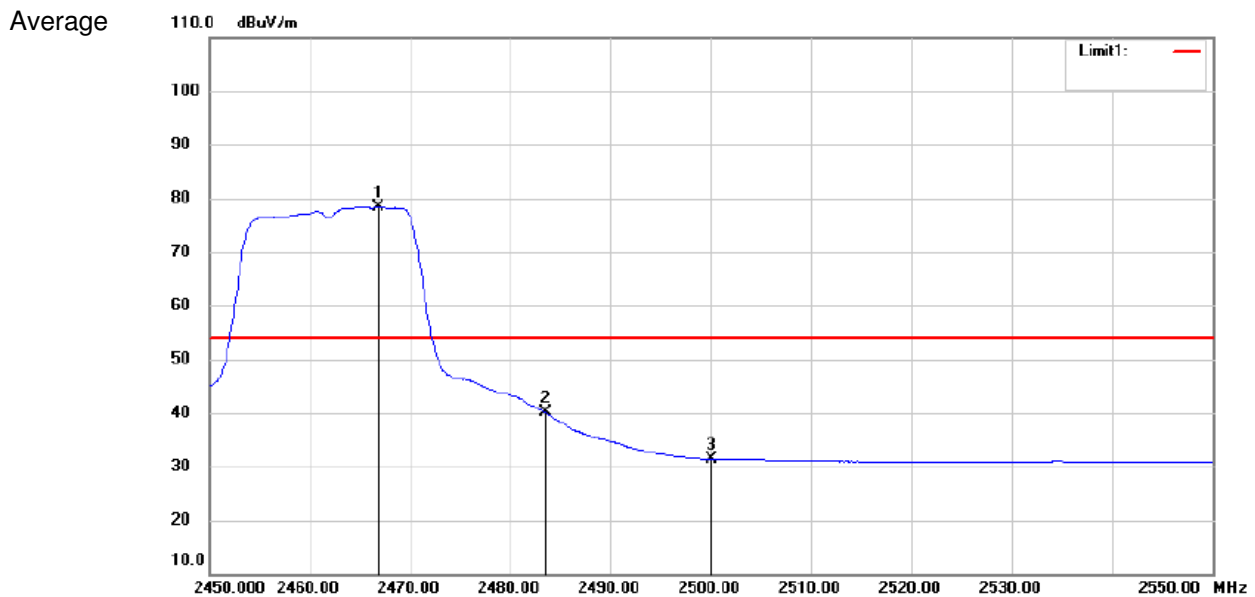
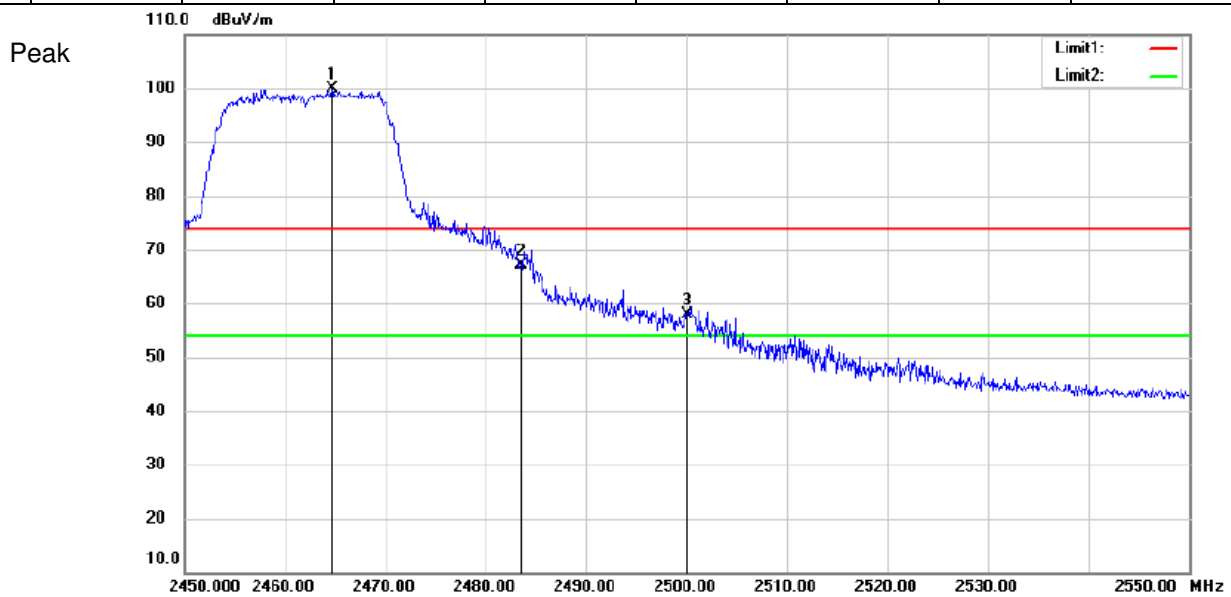

Test Mode: 802.11n20

Channel: Lowest

MK.	Frequency (MHz)	Reading (dBUV/m)	Corrected factor(dB)	Result (dBUV/m)	Limit (dBUV/m)	Over Limit (dB)	Detector	Polarization
1	2390	64.81	-3.89	60.92	74	-13.08	Peak	Horizontal
2	2410.8	102.87	-3.92	98.95	74	24.95	Peak	Horizontal
1	2390	40.96	-3.89	37.07	54	-16.93	Average	Horizontal
2	2410.68	81.77	-3.93	77.84	54	23.84	Average	Horizontal

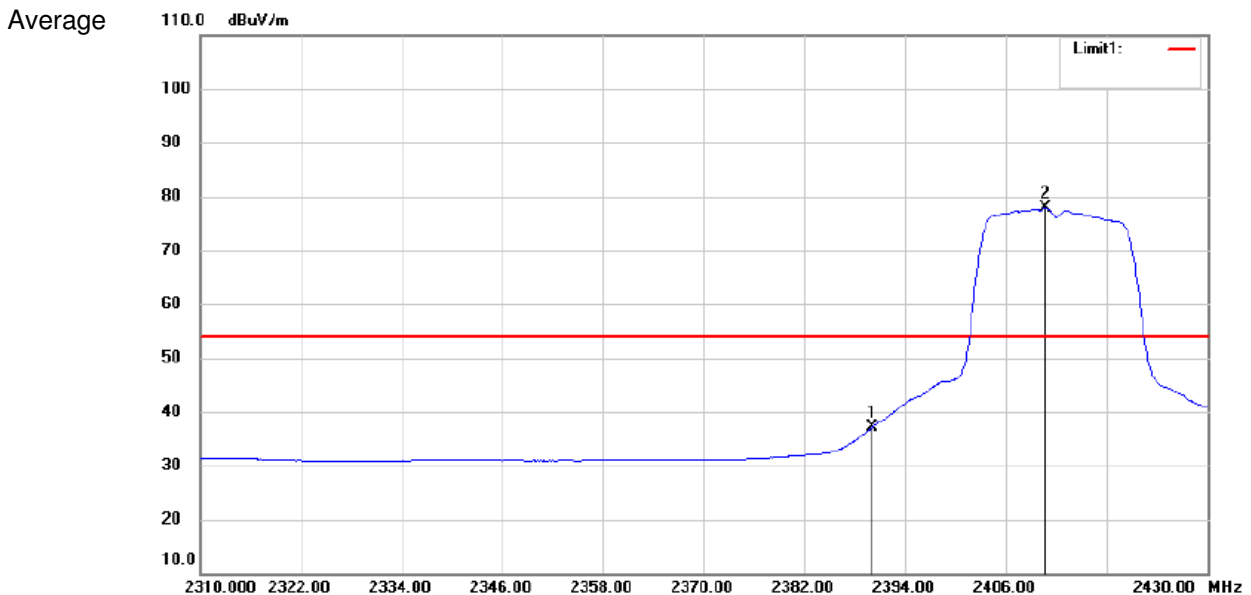
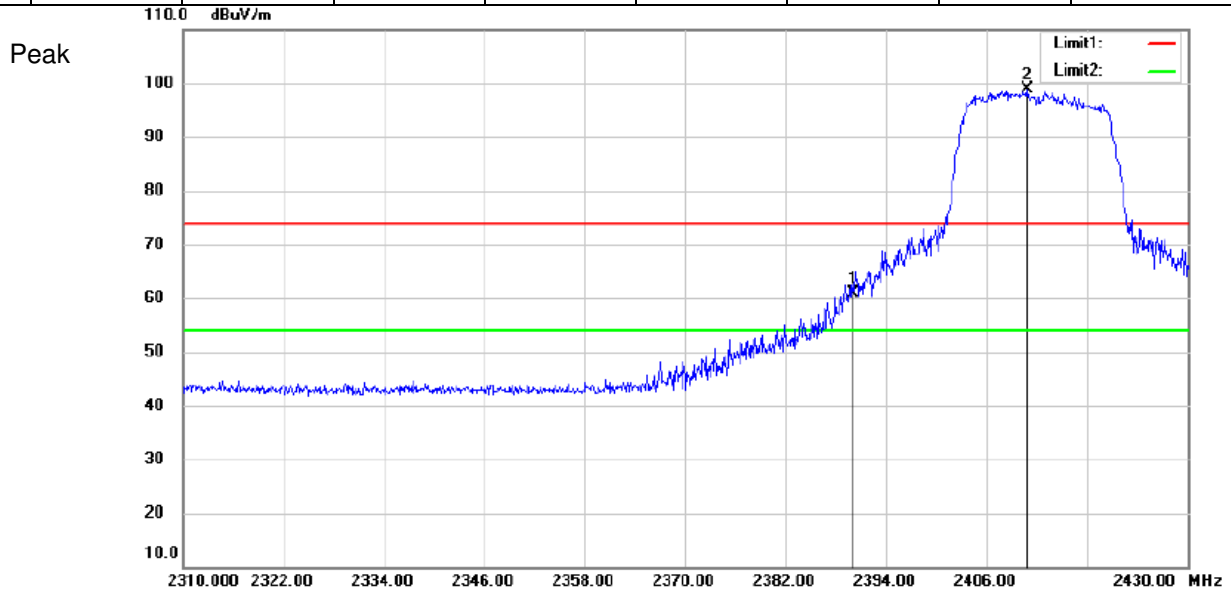

Test Mode: 802.11n20

Channel: Lowest

MK.	Frequency (MHz)	Reading (dBuV/m)	Corrected factor(dB)	Result (dBuV/m)	Limit (dBuV/m)	Over Limit (dB)	Detector	Polarization
1	2390	67.29	-3.89	63.40	74	-10.60	Peak	Vertical
2	2413.44	103.09	-3.93	99.16	74	25.16	Peak	Vertical
1	2390	40.65	-3.89	36.76	54	-17.24	Average	Vertical
2	2410.8	81.60	-3.92	77.68	54	23.68	Average	Vertical

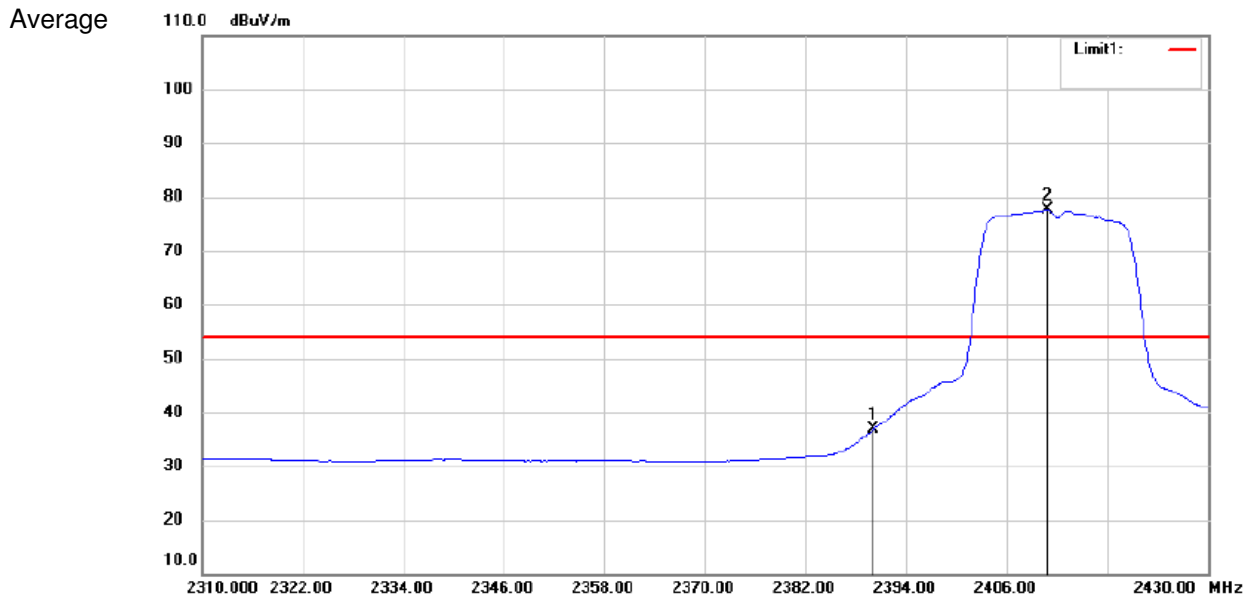
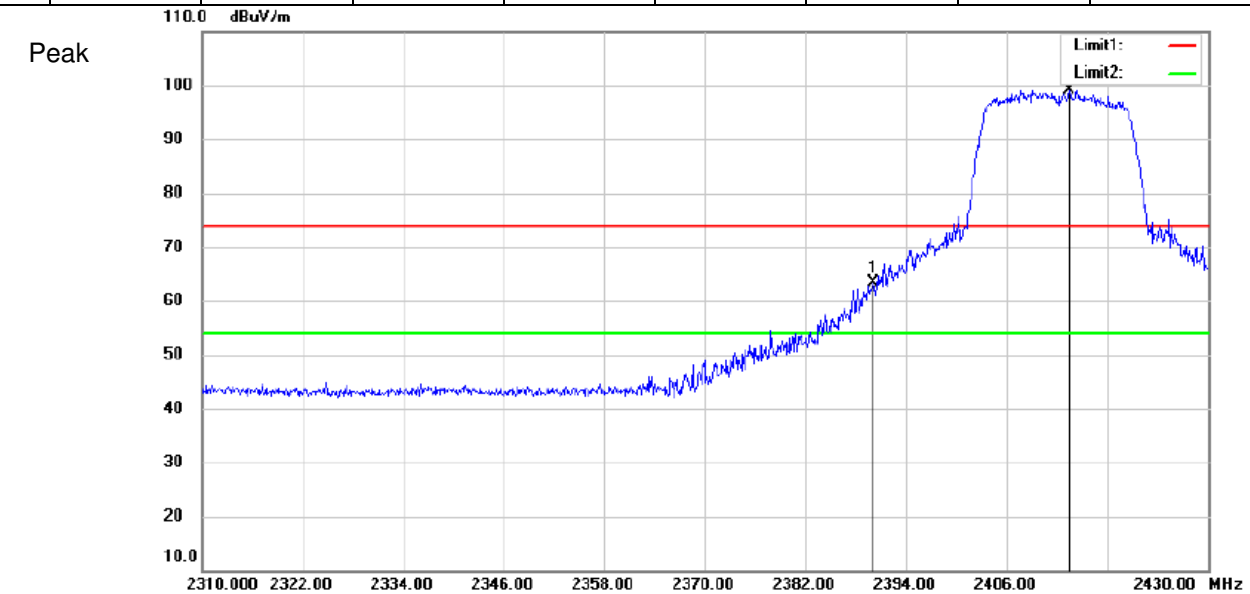

Test Mode: 802.11n20

Channel: Highest

MK.	Frequency (MHz)	Reading (dBuV/m)	Corrected factor(dB)	Result (dBuV/m)	Limit (dBuV/m)	Over Limit (dB)	Detector	Polarization
1	2460.1	102.71	-3.98	98.73	74	24.73	Peak	Horizontal
2	2483.5	70.63	-4.01	66.62	74	-7.38	Peak	Horizontal
3	2500	58.40	-4.03	54.37	74	-19.63	Peak	Horizontal
1	2460.7	81.63	-3.99	77.64	54	23.64	Average	Horizontal
2	2483.5	43.88	-4.01	39.87	54	-14.13	Average	Horizontal
3	2500	35.83	-4.03	31.80	54	-22.20	Average	Horizontal

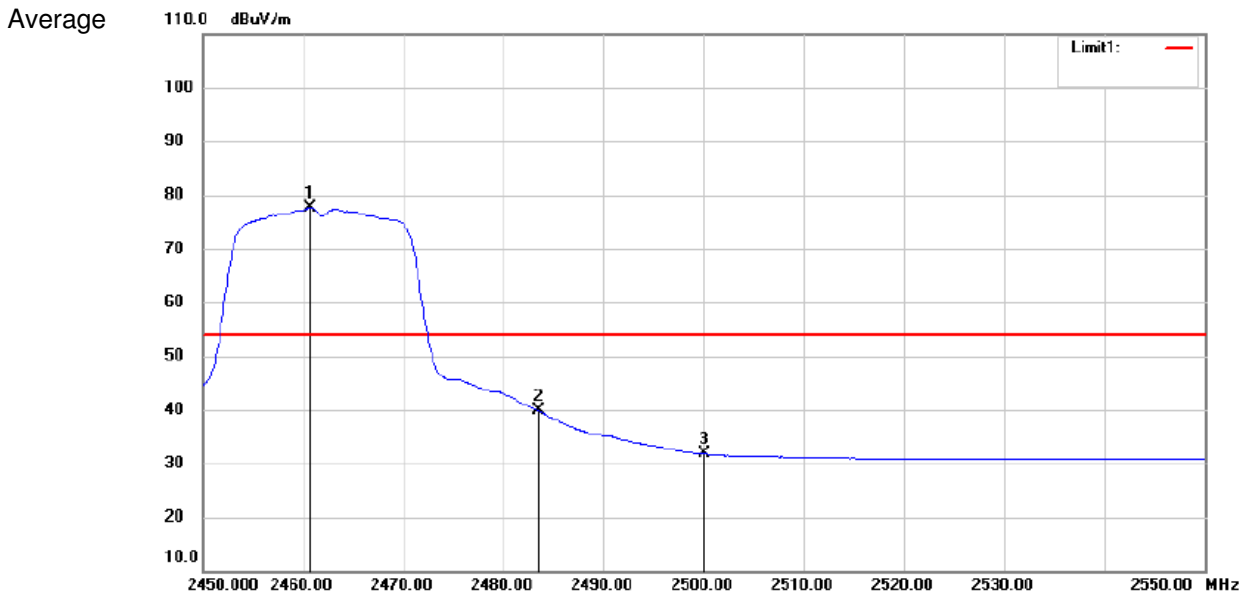
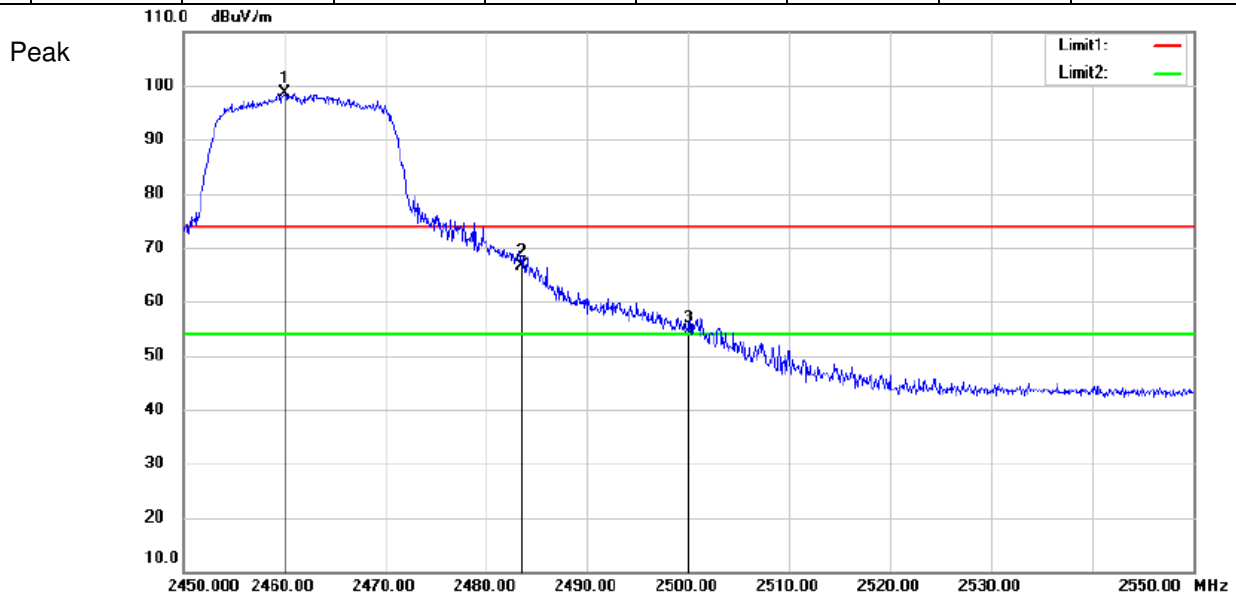

Test Mode: 802.11n20

Channel: Highest

MK.	Frequency (MHz)	Reading (dBuV/m)	Corrected factor(dB)	Result (dBuV/m)	Limit (dBuV/m)	Over Limit (dB)	Detector	Polarization
1	2465.2	102.86	-4.00	98.86	74	24.86	Peak	Vertical
2	2483.5	71.08	-4.01	67.07	74	-6.93	Peak	Vertical
3	2500	58.27	-4.03	54.24	74	-19.76	Peak	Vertical
1	2463.3	81.78	-3.98	77.80	54	23.80	Average	Vertical
2	2483.5	43.66	-4.01	39.65	54	-14.35	Average	Vertical
3	2500	34.64	-4.03	30.61	54	-23.39	Average	Vertical

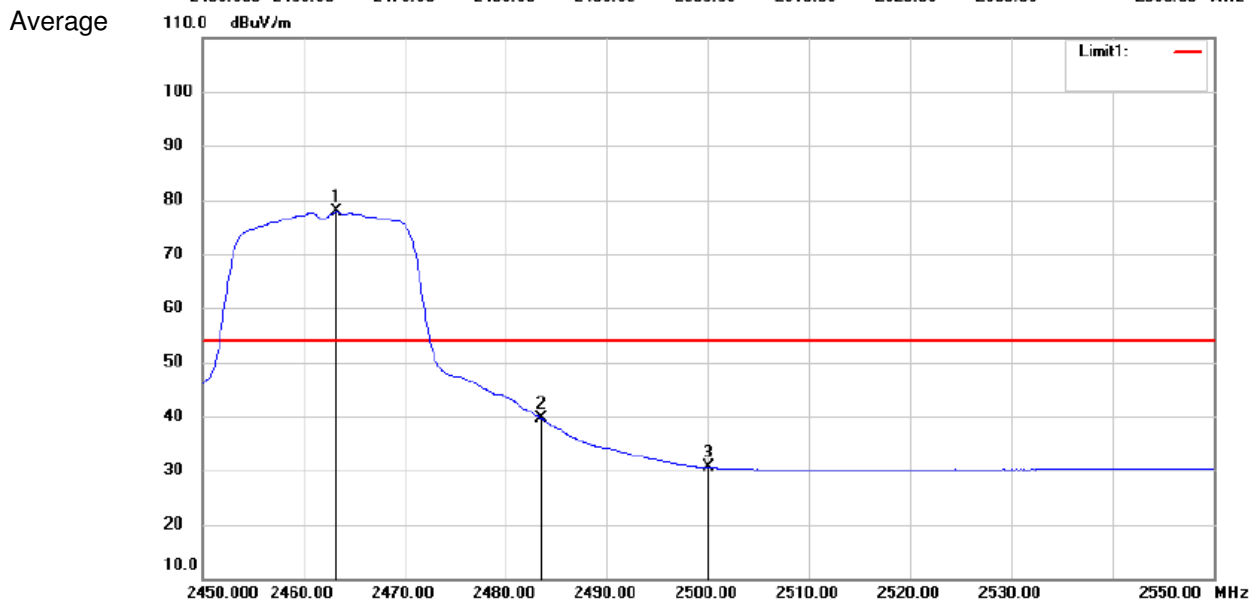
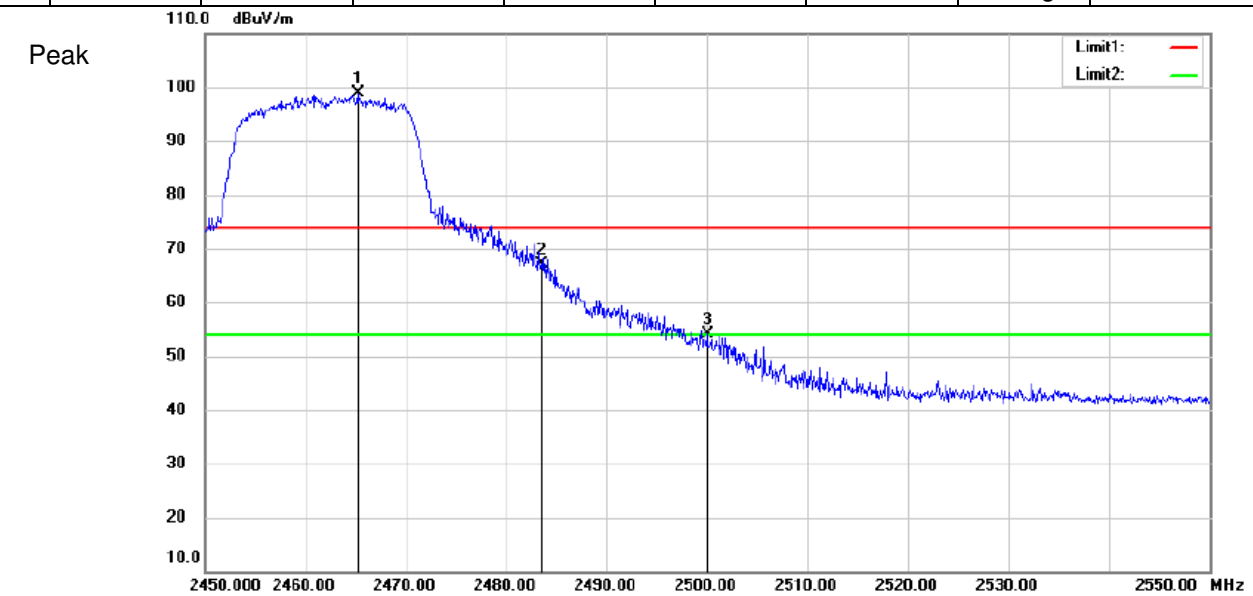

Test Mode: 802.11n40

Channel: Lowest

MK.	Frequency (MHz)	Reading (dBuV/m)	Corrected factor(dB)	Result (dBuV/m)	Limit (dBuV/m)	Over Limit (dB)	Detector	Polarization
1	2390	69.51	-3.89	65.62	74	-8.38	Peak	Horizontal
2	2412.76	98.15	-3.93	94.22	74	20.22	Peak	Horizontal
1	2390	43.89	-3.89	40.00	54	-14.00	Average	Horizontal
2	2408.14	74.44	-3.93	70.51	54	16.51	Average	Horizontal

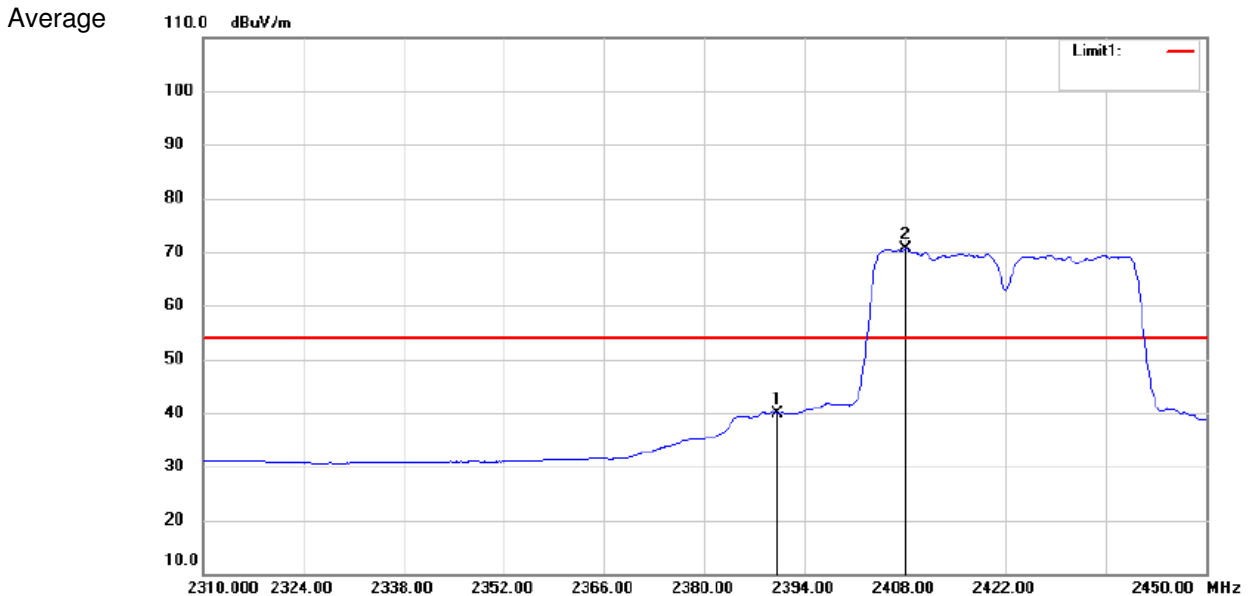
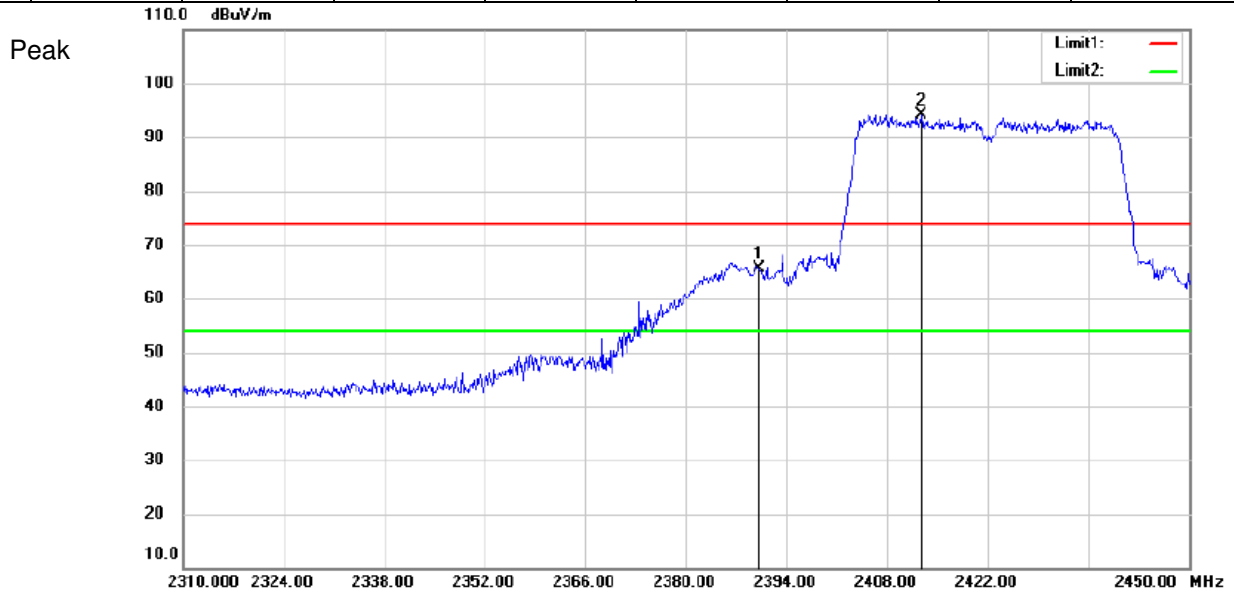

Test Mode: 802.11n40

Channel: Lowest

MK.	Frequency (MHz)	Reading (dBuV/m)	Corrected factor(dB)	Result (dBuV/m)	Limit (dBuV/m)	Over Limit (dB)	Detector	Polarization
1	2390	70.04	-3.89	66.15	74	-7.85	Peak	Vertical
2	2409.54	98.35	-3.93	94.42	74	20.42	Peak	Vertical
1	2390	44.11	-3.89	40.22	54	-13.78	Average	Vertical
2	2408.28	74.57	-3.93	70.64	54	16.64	Average	Vertical

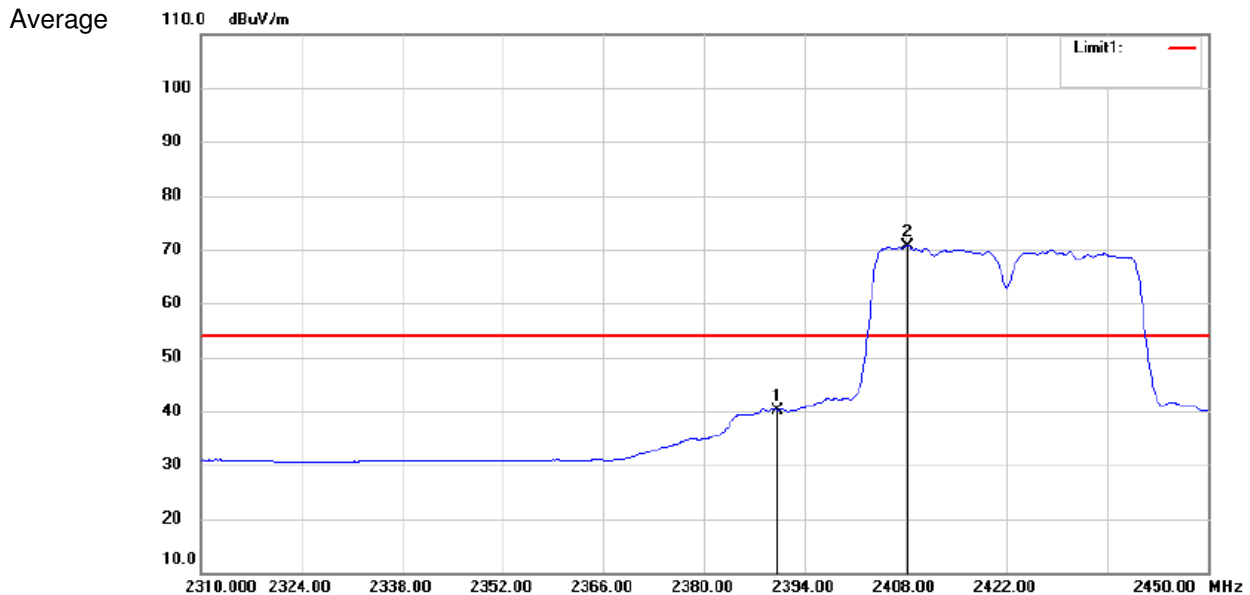
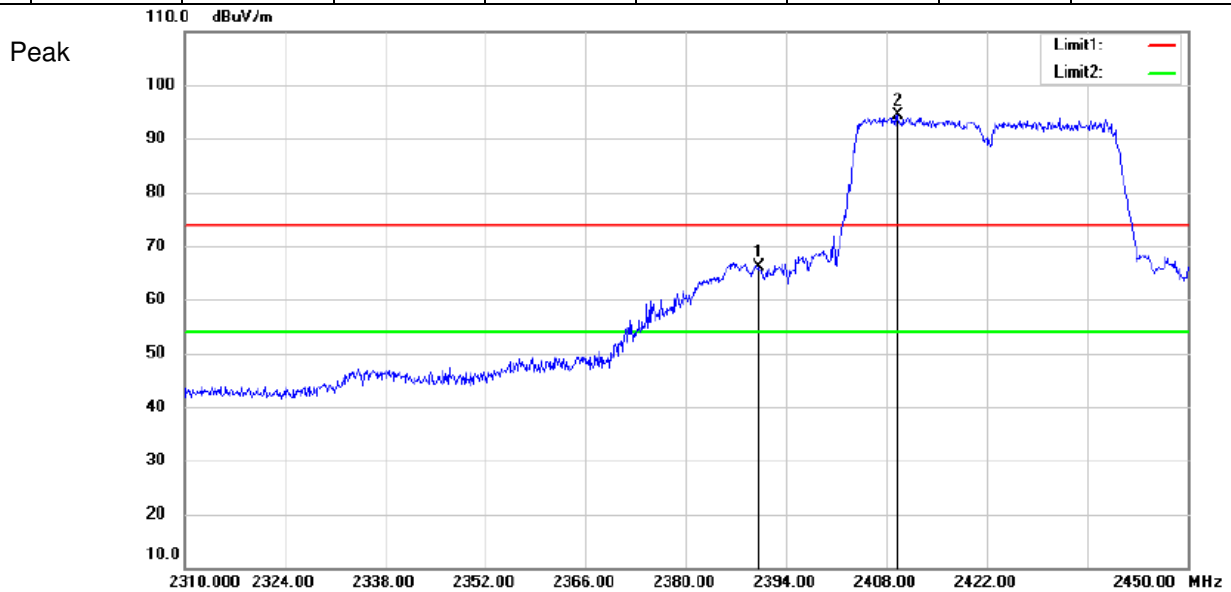

Test Mode: 802.11n40

Channel: Highest

MK.	Frequency (MHz)	Reading (dBuV/m)	Corrected factor(dB)	Result (dBuV/m)	Limit (dBuV/m)	Over Limit (dB)	Detector	Polarization
1	2441.4	98.95	-3.97	94.98	74	20.98	Peak	Horizontal
2	2483.5	73.59	-4.01	69.58	74	-4.42	Peak	Horizontal
3	2500	65.53	-4.03	61.50	74	-12.50	Peak	Horizontal
1	2445.6	73.76	-3.97	69.79	54	15.79	Average	Horizontal
2	2483.5	43.39	-4.01	39.38	54	-14.62	Average	Horizontal
3	2500	38.08	-4.03	34.05	54	-19.95	Average	Horizontal

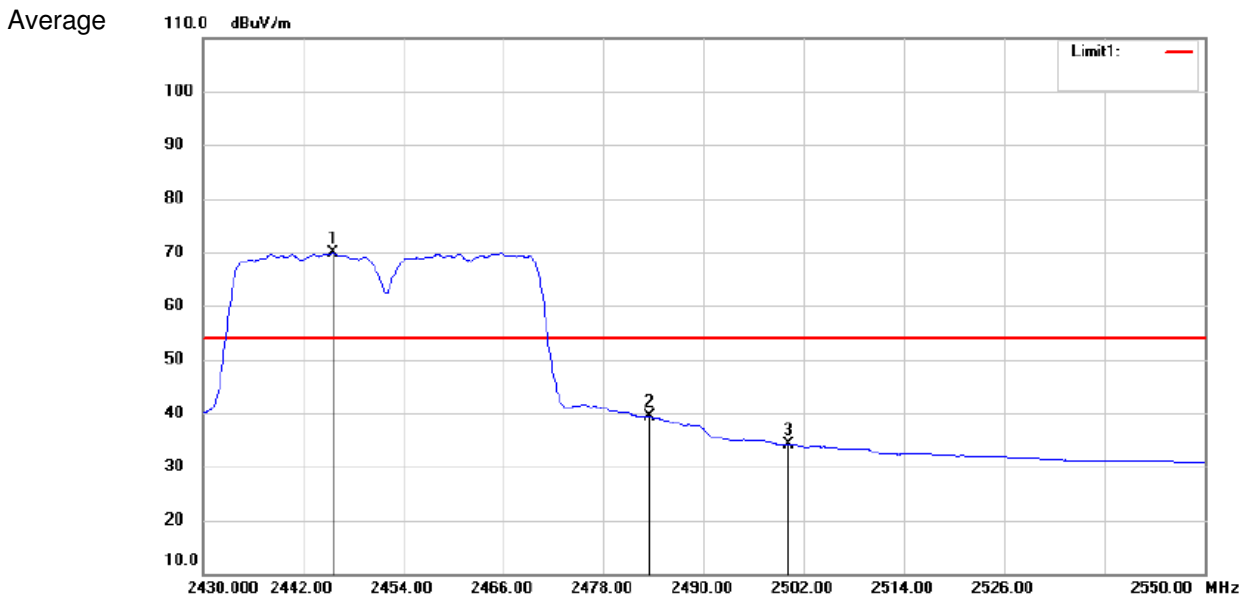
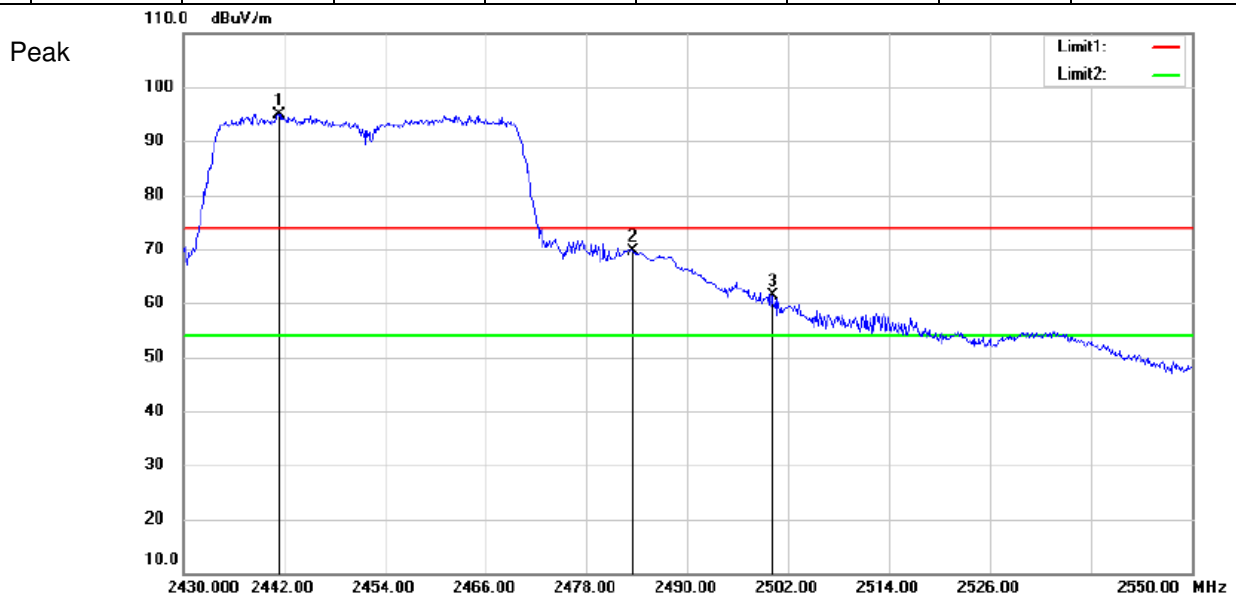

Test Mode: 802.11n40

Channel: Highest

MK.	Frequency (MHz)	Reading (dBuV/m)	Corrected factor(dB)	Result (dBuV/m)	Limit (dBuV/m)	Over Limit (dB)	Detector	Polarization
1	2463	99.52	-3.99	95.53	74	21.53	Peak	Vertical
2	2483.5	74.61	-4.01	70.60	74	-3.40	Peak	Vertical
3	2500	62.04	-4.03	58.01	74	-15.99	Peak	Vertical
1	2460.72	74.93	-3.98	70.95	54	16.95	Average	Vertical
2	2483.5	44.76	-4.01	40.75	54	-13.25	Average	Vertical
3	2500	37.47	-4.03	33.44	54	-20.56	Average	Vertical

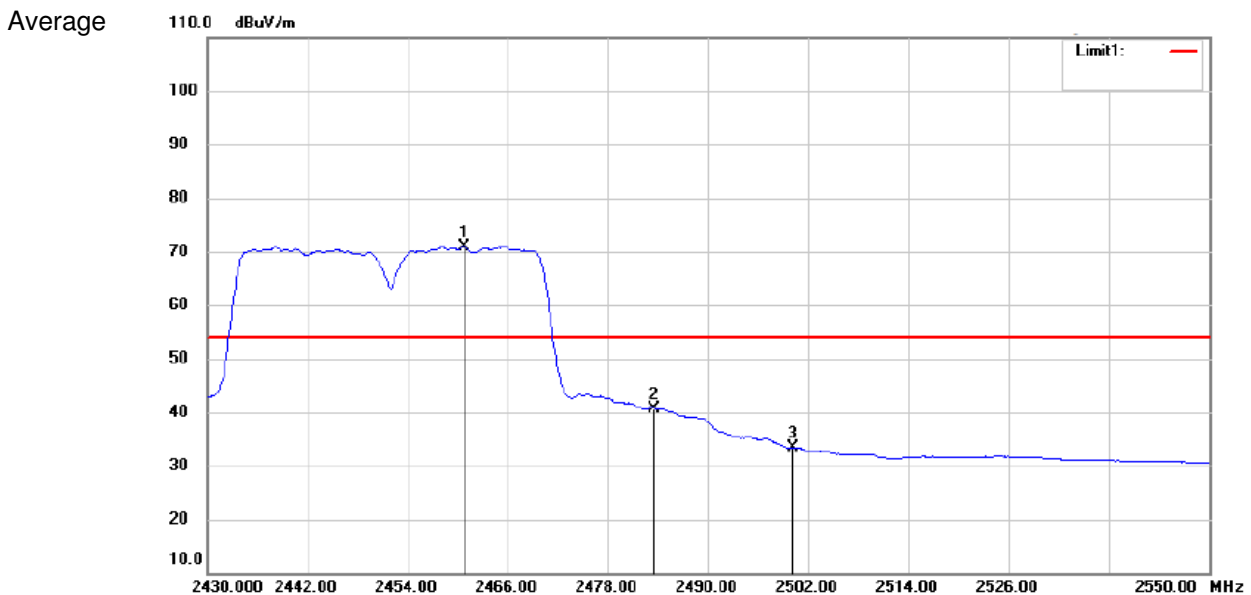
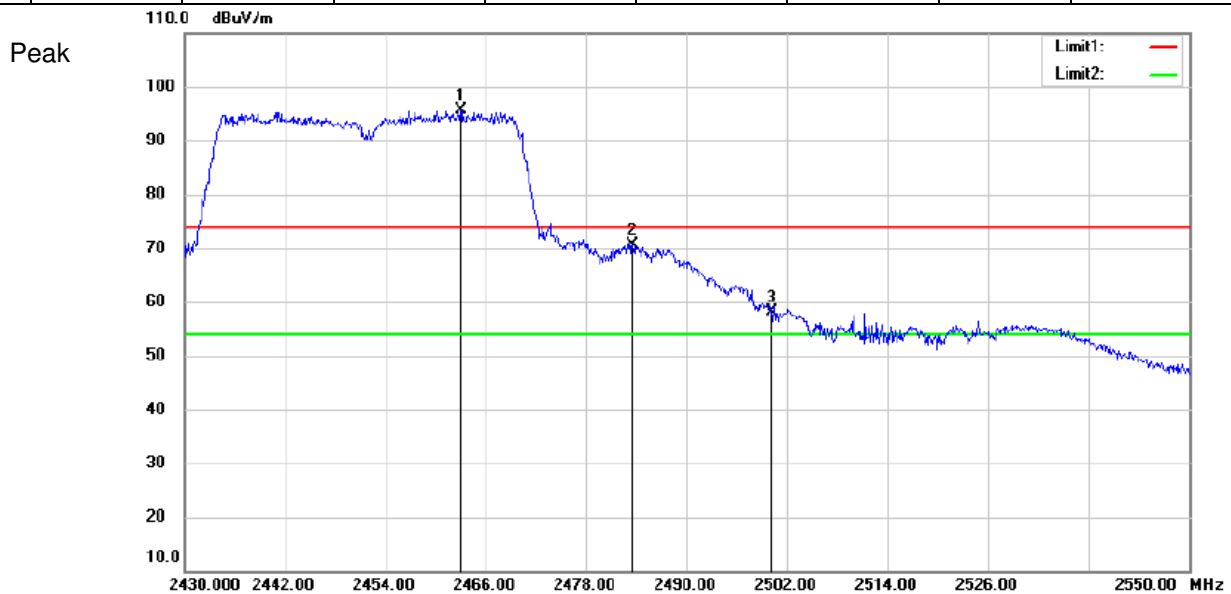

- Remark: 1. Test Level = Receiver Reading + Antenna Factor + Cable Loss- Preamplifier Factor
2. No any other emission which falls in restricted bands can be detected and be reported.
3. If the Peak value below the AV Limit, the AV test doesn't perform for this submission.

All frequencies within the "Restricted bands" have been evaluated to compliance. Section 15.205
Restricted bands of operation.

Except as shown in paragraph (d) of this section, only spurious emissions are permitted in any of the
frequency bands listed below:

MHz	MHz	MHz	GHz
0.090 - 0.110	16.42 - 16.423	399.9 - 410	4.5 - 5.15
¹ 0.495 - 0.505	16.69475 - 16.69525	608 - 614	5.35 - 5.46
2.1735 - 2.1905	16.80425 - 16.80475	960 - 1240	7.25 - 7.75
4.125 - 4.128	25.5 - 25.67	1300 - 1427	8.025 - 8.5
4.17725 - 4.17775	37.5 - 38.25	1435 - 1626.5	9.0 - 9.2
4.20725 - 4.20775	73 - 74.6	1645.5 - 1646.5	9.3 - 9.5
6.215 - 6.218	74.8 - 75.2	1660 - 1710	10.5 - 12.7
6.26775 - 6.26825	108 - 121.94	1718.8 - 1722.2	13.25 - 13.4
6.31175 - 6.31225	123 - 138	2200 - 2300	14.47 - 14.5
8.291 - 8.294	149.9 - 150.05	2310 - 2390	15.35 - 16.2
8.362 - 8.366	156.52475 - 156.52525	2483.5 - 2500	17.7 - 21.4
8.37625 - 8.38675	156.7 - 156.9	2655 - 2900	22.01 - 23.12
8.41425 - 8.41475	162.0125 - 167.17	3260 - 3267	23.6 - 24.0
12.29 - 12.293	167.72 - 173.2	3332 - 3339	31.2 - 31.8
12.51975 - 12.52025	240 - 285	3345.8 - 3358	36.43 - 36.5
12.57675 - 12.57725	322 - 335.4	3600 - 4400	
13.36 - 13.41			

7.9 99% Occupied Bandwidth

Test Configuration:

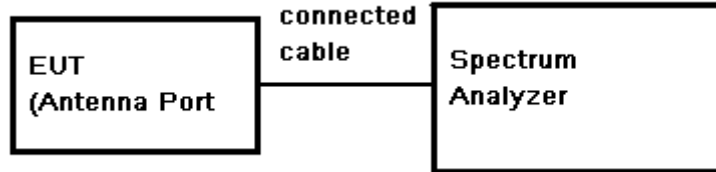

Test Procedure:

1. Remove the antenna from the EUT and then connect a low RF cable from the antenna port to the spectrum;
2. Set the spectrum analyzer: Span = approximately 2 to 3 times the 20dB bandwidth, centred on the hopping channel;
3. Set the spectrum analyzer: RBW \geq 1% of the 20dB bandwidth (set 1MHz). VBW \geq RBW. Sweep = auto; Detector Function = Peak. Trace = Max Hold.
4. Mark the peak frequency and -20dB points.

Test Result:

Pass

Test Date:

Test Mode	Channel (MHz)	Bandwidth (MHz)
802.11b	Lowest (2412)	12.42
	Middle (2437)	12.39
	Highest (2462)	12.39
802.11g	Lowest (2412)	16.74
	Middle (2437)	16.71
	Highest (2462)	16.74
802.11n20	Lowest (2412)	17.73
	Middle (2437)	17.79
	Highest (2462)	17.76
802.11n40	Lowest (2422)	36.32
	Middle (2437)	36.40
	Highest (2452)	36.40

Test plot as follows:

Test Mode:	802.11b	Channel:	Lowest
-------------------	----------------	-----------------	---------------

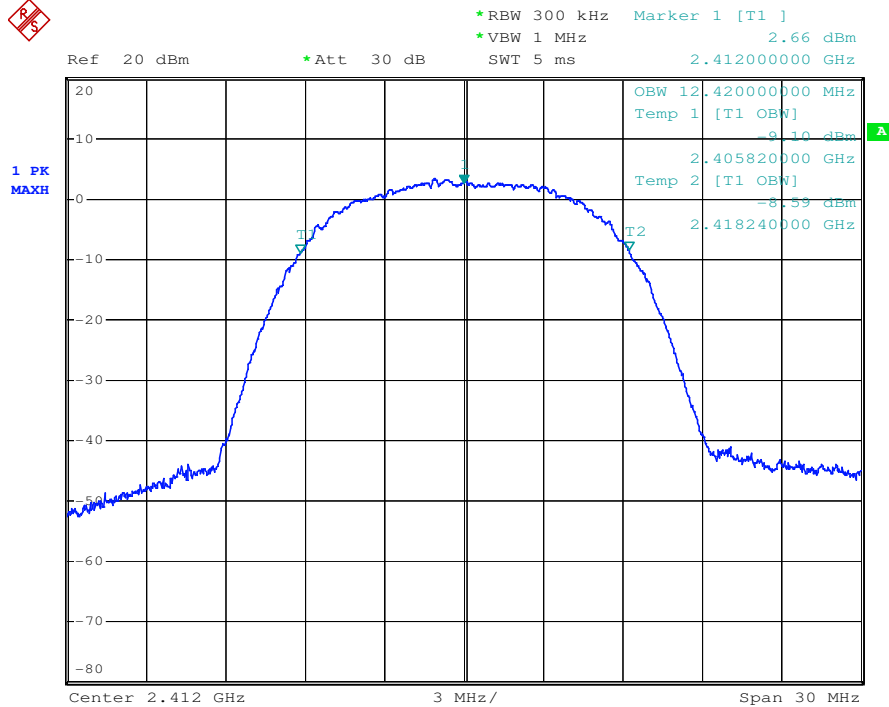

Test Mode:	802.11b	Channel:	Middle
-------------------	----------------	-----------------	---------------

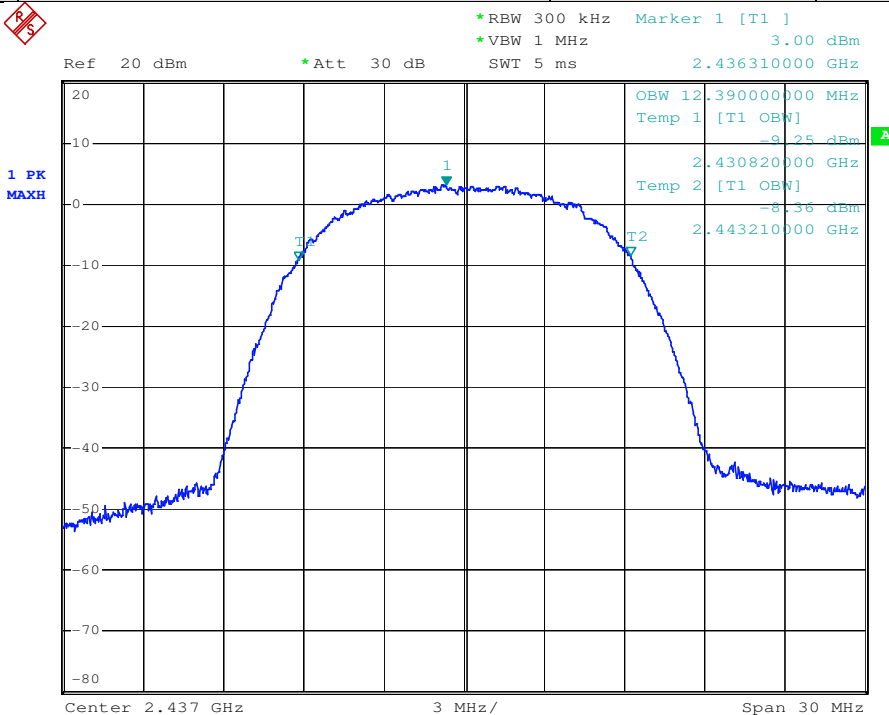



Test Mode:	802.11b	Channel:	Highest
------------	---------	----------	---------

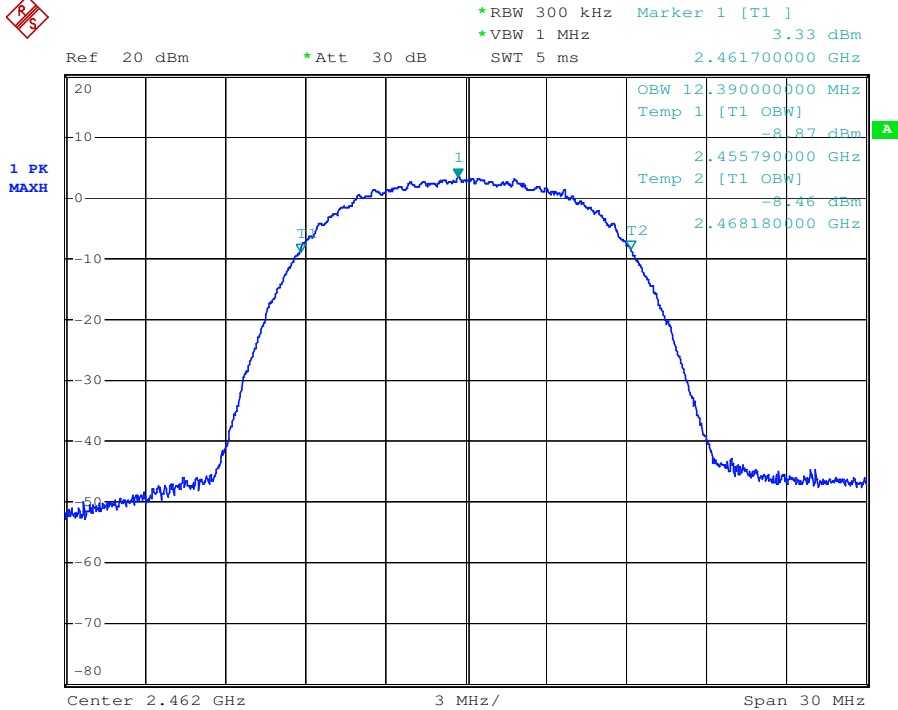

Test Mode:	802.11g	Channel:	Lowest
------------	---------	----------	--------

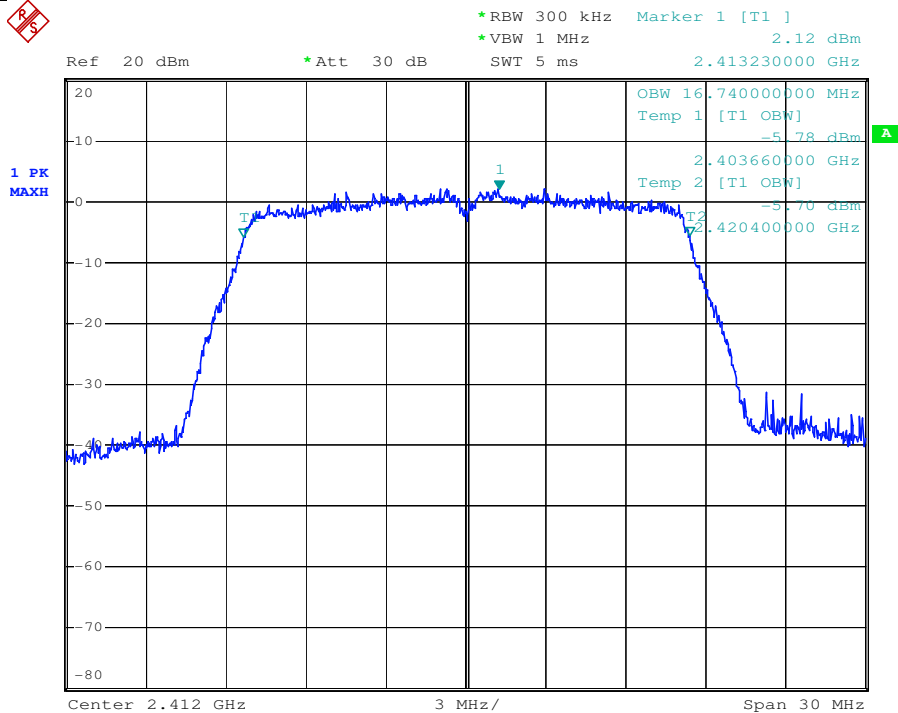



Test Mode:	802.11g	Channel:	Middle
------------	---------	----------	--------

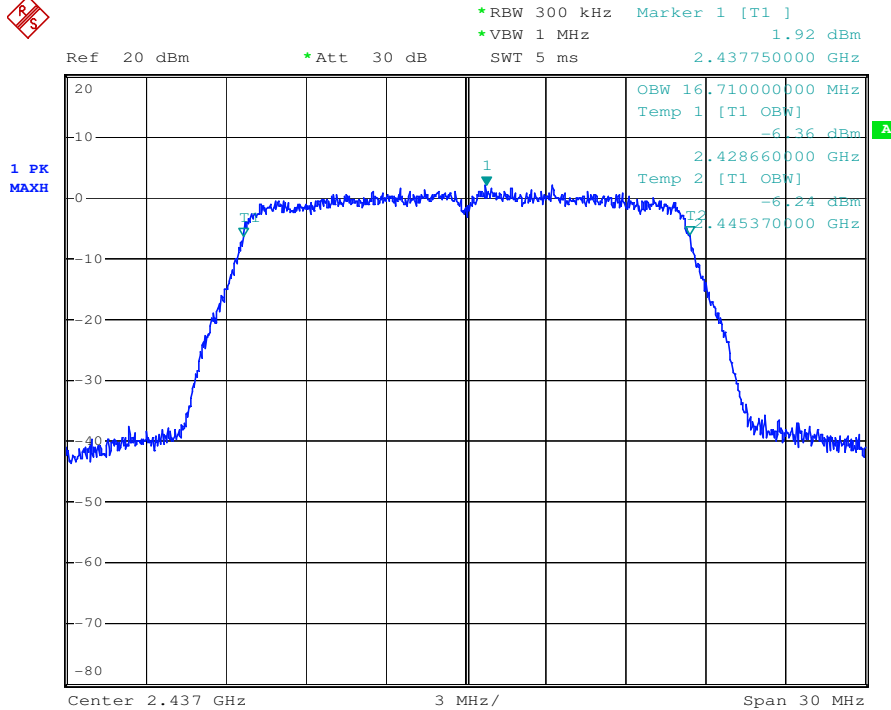

Test Mode:	802.11g	Channel:	Highest
------------	---------	----------	---------

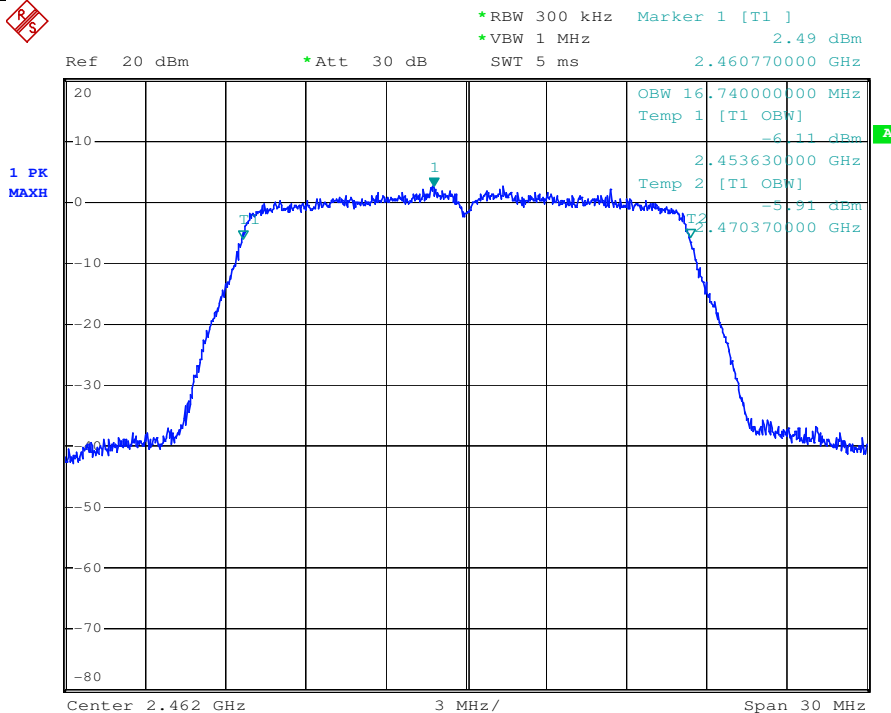

Test Mode:	802.11n20	Channel:	Lowest
-------------------	------------------	-----------------	---------------

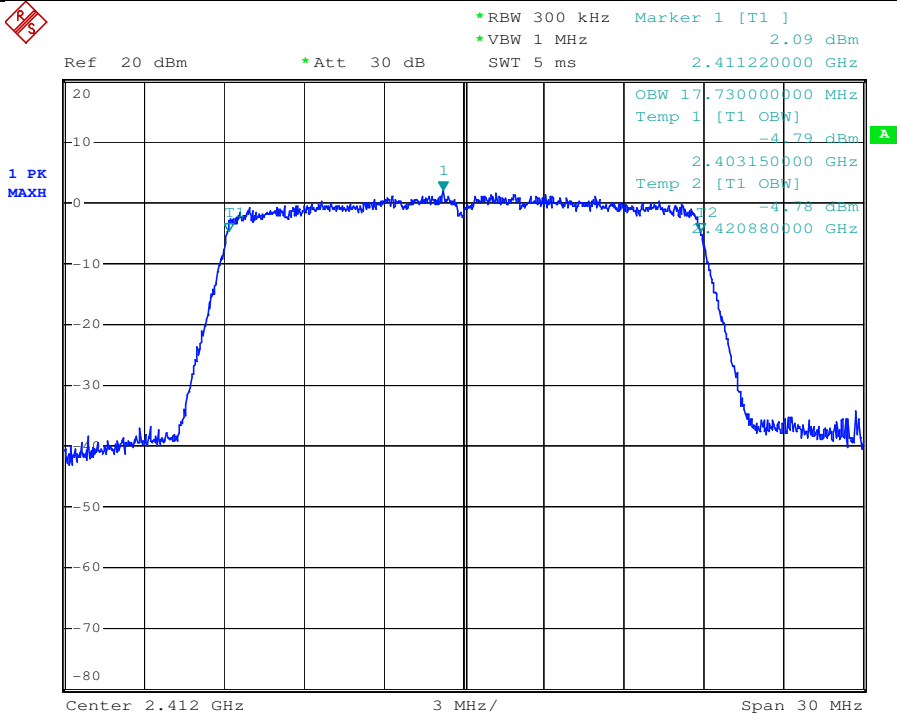

Test Mode:	802.11n20	Channel:	Middle
-------------------	------------------	-----------------	---------------

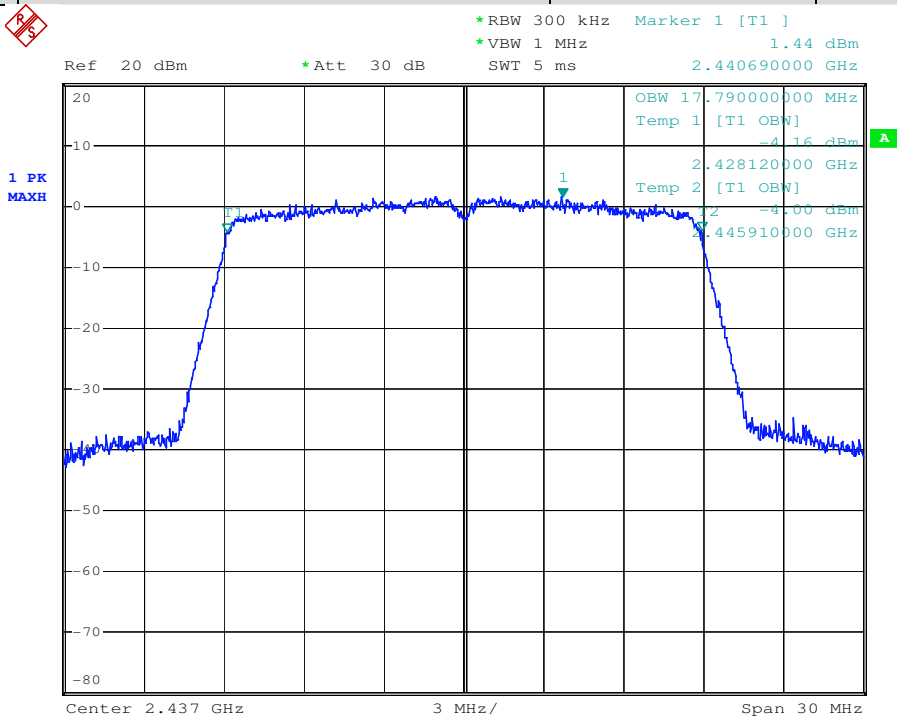

Test Mode:	802.11n20	Channel:	Highest
-------------------	------------------	-----------------	----------------

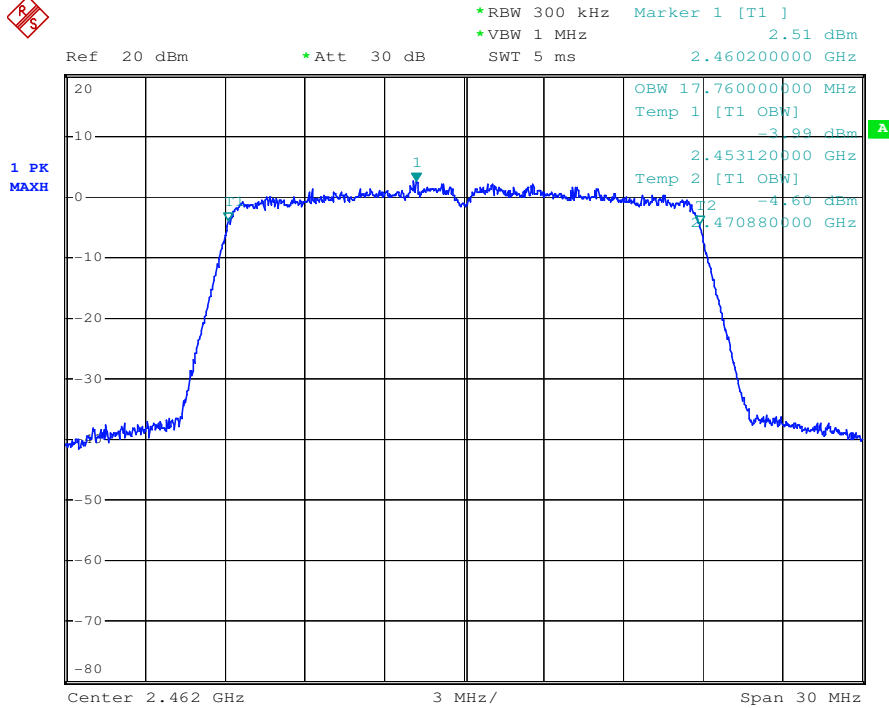

Test Mode:	802.11n40	Channel:	Lowest
-------------------	------------------	-----------------	---------------

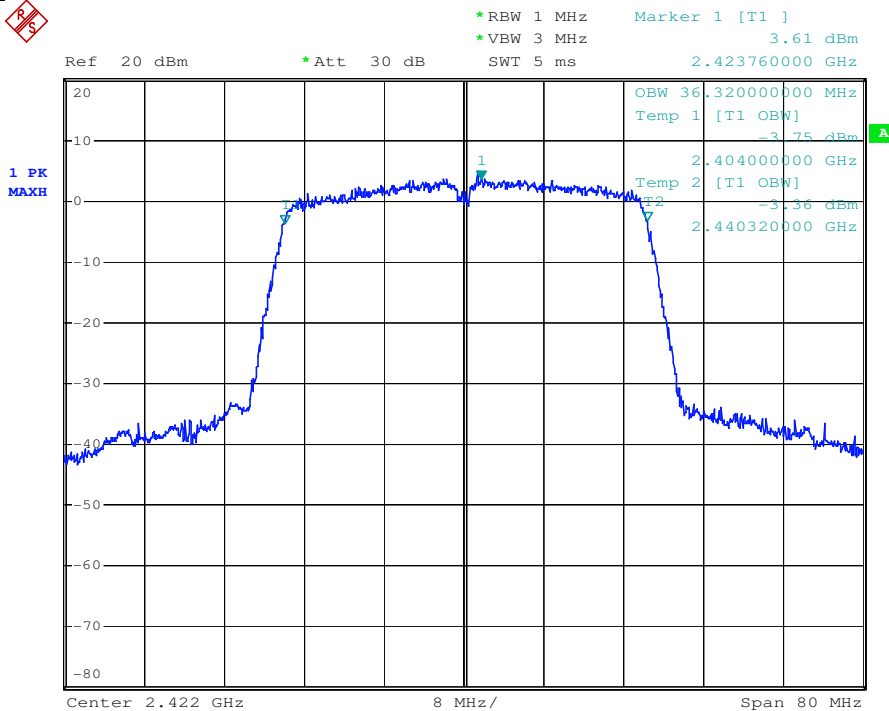

Test Mode:	802.11n40	Channel:	Middle
-------------------	------------------	-----------------	---------------

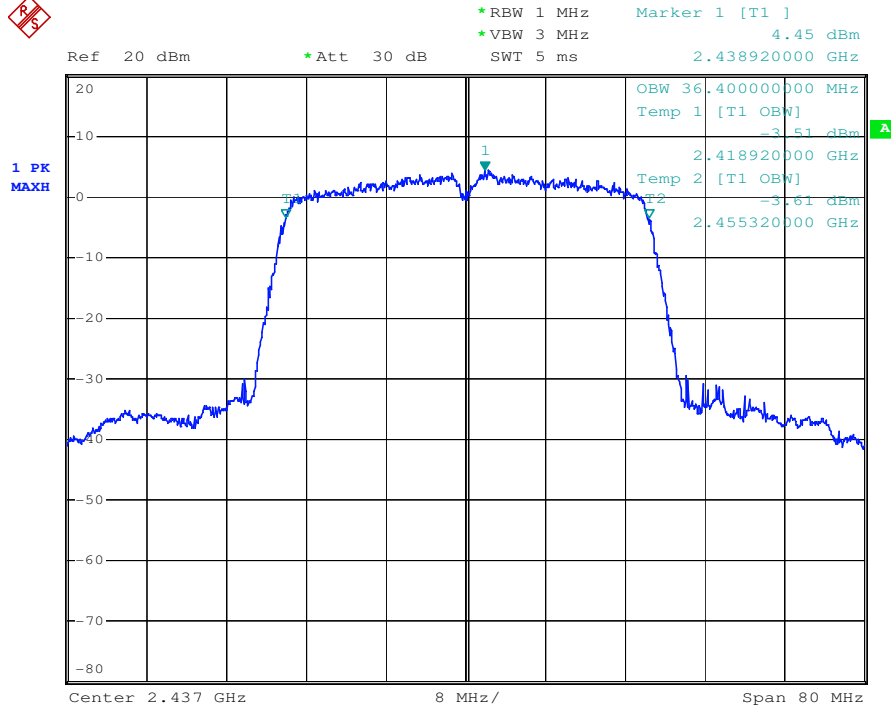

Test Mode:	802.11n40	Channel:	Highest
-------------------	------------------	-----------------	----------------

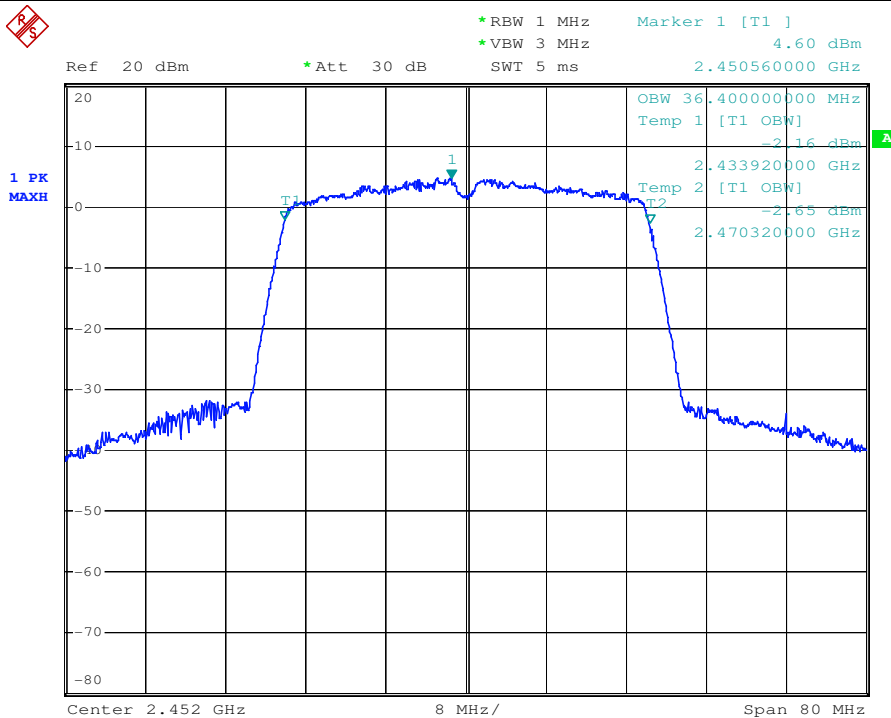

8 Test Setup Photographs

Refer to the < HS5S _Test Setup photos-FCC>.

9 EUT Constructional Details

Refer to the < HS5S _External Photos-FCC > & < HS5S_Internal Photos-FCC>.

--End of the Report--