

# **Moxa IEEE 802.11a/b/g/n MiniPCI Module**

---

## **WAPN001 User's Manual**

***www.moxa.com***

**First Edition, July 2010**

**MOXA<sup>®</sup>**

© 2009 Moxa Inc. All rights reserved.  
Reproduction without permission is prohibited.

# WAPN001 User's Manual

The hardware and software described in this manual is furnished under a license agreement and may be used only in accordance with the terms of that agreement.

## Copyright Notice

Copyright © 2009 Moxa Inc.  
All rights reserved.  
Reproduction without permission is prohibited.

## Trademarks

MOXA is a registered trademark of Moxa Inc.  
All other trademarks or registered marks in this manual belong to their respective manufacturers.

## Disclaimer

Information in this document is subject to change without notice and does not represent a commitment on the part of Moxa.

Moxa provides this document “as is,” without warranty of any kind, either expressed or implied, including, but not limited to, its particular purpose. Moxa reserves the right to make improvements and/or changes to this manual, or to the products and/or the programs described in this manual, at any time.

Information provided in this manual is intended to be accurate and reliable. However, Moxa assumes no responsibility for its use, or for any infringements on the rights of third parties that may result from its use.

This product might include unintentional technical or typographical errors. Changes are periodically made to the information herein to correct such errors, and these changes are incorporated into new editions of the publication.

## Technical Support Contact Information

**[www.moxa.com/support](http://www.moxa.com/support)**

### Moxa Americas:

Toll-free: 1-888-669-2872

Tel: +1-714-528-6777

Fax: +1-714-528-6778

### Moxa China (Shanghai office):

Toll-free: 800-820-5036

Tel: +86-21-5258-9955

Fax: +86-10-6872-3958

### Moxa Europe:

Tel: +49-89-3 70 03 99-0

Fax: +49-89-3 70 03 99-99

### Moxa Asia-Pacific:

Tel: +886-2-8919-1230

Fax: +886-2-8919-1231

# Table of Contents

## **Chapter 1 Introduction**

Overview  
Features  
Specification

## **Chapter 2 Getting Started**

Module Layout  
Block Diagram  
Hardware Installation  
Software Installation

# 1

## Introduction

---

The following topics are covered in this chapter:

D **Overview**

D

D Features

D **Specifications**

## Overview

WAPN001 Mini-PCI Module is designed to provide wireless communication for all wireless device based systems. It communicates via the standard 802.11a/b/g/n protocols. The WAPN001 uses the AR9220 wireless chipset from Atheros. This module is connected to the PCI bus through a Mini-PCI connector and special circuitry to allow for compatibility with either 3.3V or 5V PCI signaling.

## Features

- Dynamic frequency selection (DFS) in required 5-GHz bands
- All-CMOS MIMO solution interoperable with IEEE 802.11a/b/g/n WLANs
- 2x2 MIMO technology improves effective throughput and range over existing 802.11a/b/g products
- Supports spatial multiplexing, cyclic-delay diversity (CDD), and maximal ratio combining (MRC)
- 2.4/5 GHz WLAN MAC/BB processing
- BPSK, QPSK, 16 QAM, 64 QAM, DBPSK, DQPSK, and CCK modulation schemes
- Data rates of up to 144.4 Mbps for 20 MHz channels and 300 Mbps for 40 MHz channels
- Wireless multimedia enhancements quality of service support (QoS)
- 802.11e-compatible bursting
- WEP, TKIP, and AES hardware encryption
- 337-pin, 12 mm x 12 mm BGA package
- Case temperature 85°C

## Specification

Features	WAPN001
Chipset	Atheros AR9220
Baseband Processor (BBP)	<ul style="list-style-type: none"><li>· DSS with DBPSK, DQPSK, CCK</li><li>· OFDM with BPSK, QPSK, 16QAM, 64QAM</li><li>· 802.11b: CCK@11/5.5 Mbps, DQPSK@2 Mbps, DBPSK@11 Mbps</li><li>· 802.11a/g: 64QAM@54/48 Mbps, 16QAM@36/24 Mbps, QPSK@18/12 Mbps</li><li>· BPSK@9/6 Mbps</li><li>· 802.11n: 64QAM@300 to BPSK@6.5 Mbps (multiple rates supported)</li></ul>
security engine	WEP64, WEP128, WEP256, AES-CCM, TKIP, WPS
Bus Interface	Mini PCI standard bus complaint
Connectors	Defined BTB connector is using 2x40 pins header, and Support Mini-PCI standard.
Power requirement	1.2V +/-5% 1.8V +/-5% 3.3V +/-10%
Dimension	50mm x 49mm x 1.2mm
Weight	15g
Operating Temperature	-40 to +80 °C
Storage Temperature:	-40 to +150°C

# 2

## Getting Started

---

This chapter covers the module layout, and block diagram, hardware installation of the WAPN001. Software installation is covered in the next chapter.

The following topics are covered:

- D **Module Layout**
- D **Block Diagram**
- D **Hardware Installation**
- D **Software Installation**

## Module Layout

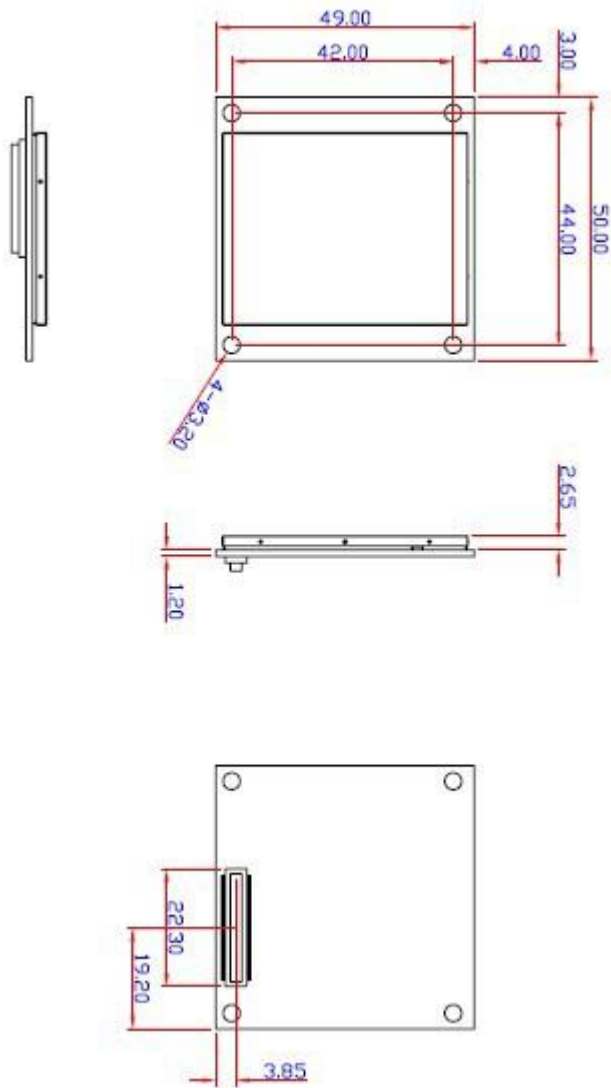



## Block Diagram

Below is a block diagram of the WAPN001. Primary board components are in bold, while external connections are italicized.

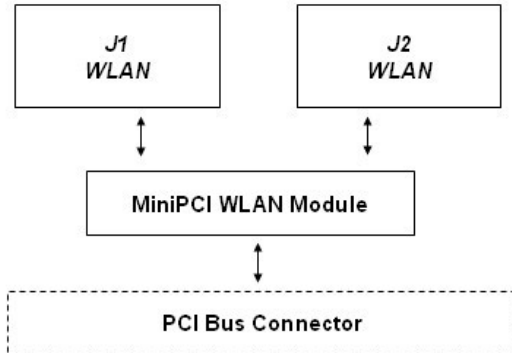

## Connector Locations

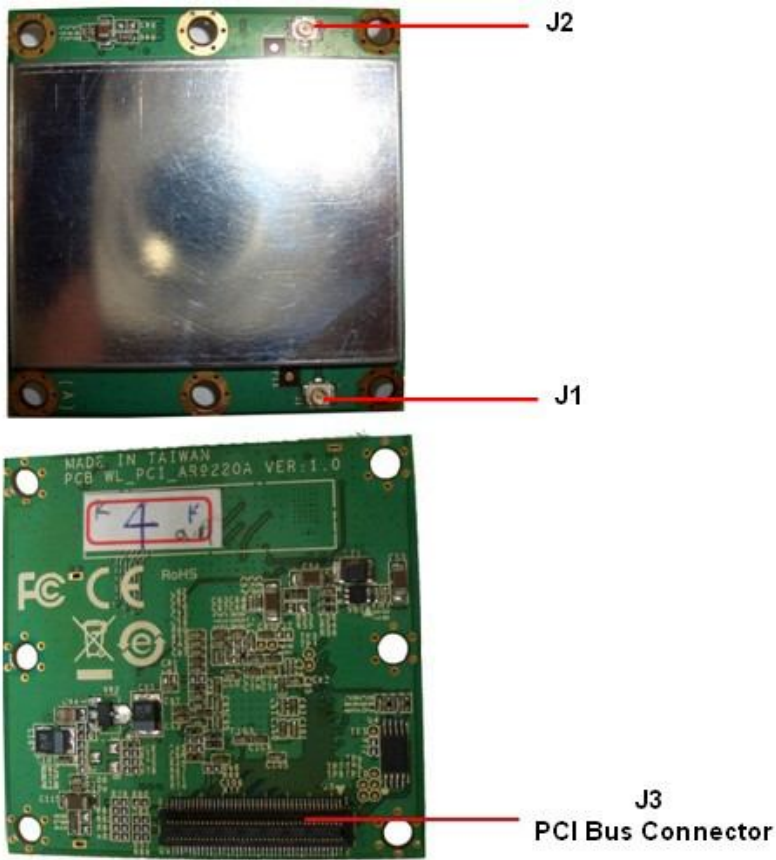

# MiniPCI Bus Connector PIN Assignments

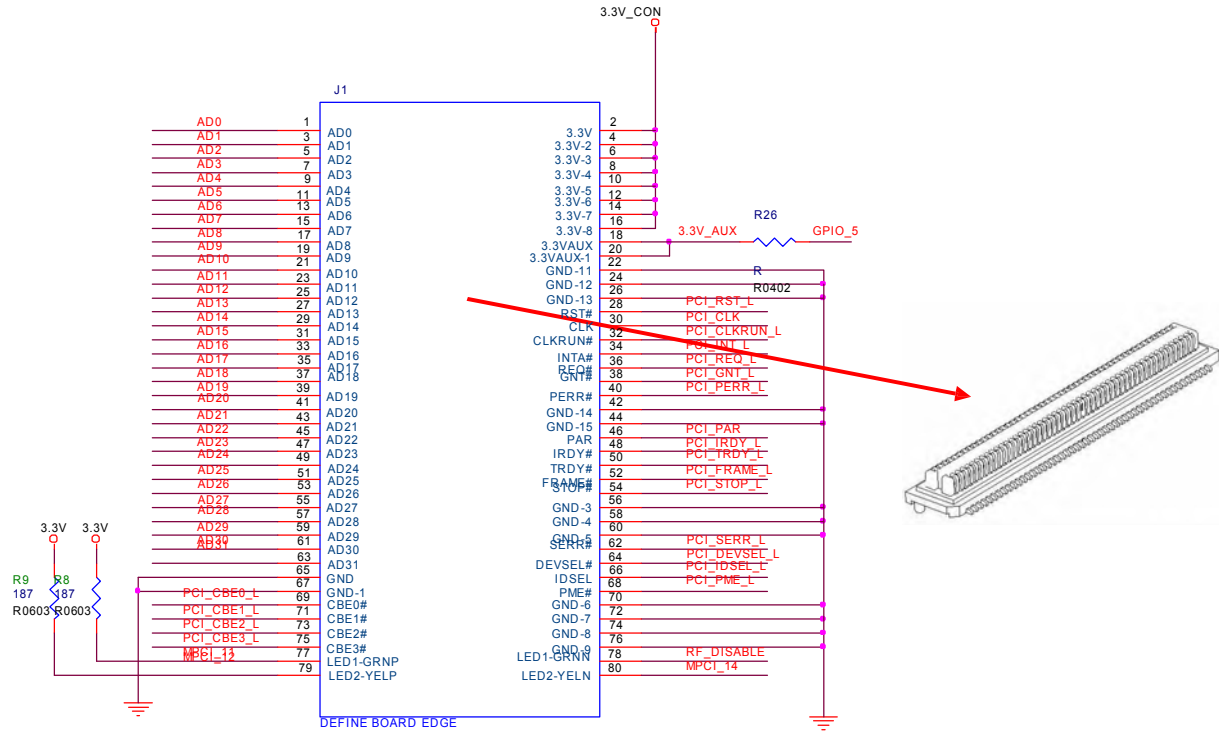

## Hardware Installation

The WAPN001 can be installed into all Moxa wireless system board series. It can be located below the CPU.

### Step for Installation

1. Attach the WLAN antenna to connector J1.
2. If using 2nd WLAN antenna, attach it to connector J2.
3. Install the WAPN001 miniPCI card on the system board. Apply pressure to both bus connectors and gently press the board onto the stack. The board should slide into the matching bus connectors. Do not attempt to force the board, as this can lead to bent/broken pins.
4. Screw on the WAPN001 miniPCI card.
5. If any power boards are to be stacked above the WAPN001, install them.
6. Screw on the all the necessary chassis.

## Software Installation

After physically installing the WAPN001, your operating system must be configured to recognize the new system board.

### Step for Installation

1. Apply power to the system board.
2. Connect system board and PC with Ethernet cable.
3. Open a browser and type: 192.168.127.253 to open the system login webpage.
4. Login the webpage with default password: root in order to verify that all of the hardware is install properly.

## Federal Communication Commission Interference Statement

This equipment has been tested and found to comply with the limits for a Class B digital device, pursuant to Part 15 of the FCC Rules. These limits are designed to provide reasonable protection against harmful interference in a residential installation. This equipment generates, uses and can radiate radio frequency energy and, if not installed and used in accordance with the instructions, may cause harmful interference to radio communications.

However, there is no guarantee that interference will not occur in a particular installation. If this equipment does cause harmful interference to radio or television reception, which can be determined by turning the equipment off and on, the user is encouraged to try to correct the interference by one of the following measures:

- Reorient or relocate the receiving antenna.
- Increase the separation between the equipment and receiver.
- Connect the equipment into an outlet on a circuit different from that to which the receiver is connected.
- Consult the dealer or an experienced radio/TV technician for help.

### FCC Caution:

To assure continued compliance, (example - use only shielded interface cables when connecting to computer or peripheral devices) any changes or modifications not expressly approved by the party responsible for compliance could void the user's authority to operate this equipment.

This device complies with Part 15 of the FCC Rules. Operation is subject to the following two conditions:

- (1) This device may not cause harmful interference, and
- (2) This device must accept any interference received, including interference that may cause undesired operation.

### IMPORTANT NOTE:

This module is restricted to mobile configuration. To comply with FCC RF exposure compliance requirements, the antenna used for this transmitter must be installed to provide a separation distance of at least 20 cm from all persons and must not be co-located or operating in conjunction with any other antenna or transmitter. This transmitter module must not be co-located or operating in conjunction with any other antenna or transmitter

### CAUTION:

Any changes or modifications not expressly approved by the grantee of this device could void the user's authority to operate the equipment.

### End Product Labeling

This transmitter module is authorized only for use in device where the antenna may be installed such that 20cm may be maintained between the antenna and users. The final end product must be labeled in a visible area with the following: "Contains FCC ID: SLE-WAPN001 "