

<b>Specification</b>	
<b>Electrical</b>	
<b>Test Environment</b>	With Housing
<b>Frequency Range</b>	2400~2500MHz / 4900~5900MHz
<b>VSWR</b>	<2 (max)
<b>Input Impedance</b>	50 ohm
<b>Isolation</b>	<-20dB
<b>Polarization</b>	Vertical / Vertical
<b>Gain(Peak gain)</b>	2.4G _7dBi
	5G _8dBi
<b>Efficiency</b>	>50%
<b>Half Power Beam Width (HPBW)</b>	2.4G
	50±10 deg @ Vertical Cut
	90±10 deg @ Horizontal Cut
	5G
	30±10 deg @ Vertical Cut
	120±10 deg @ Horizontal Cut

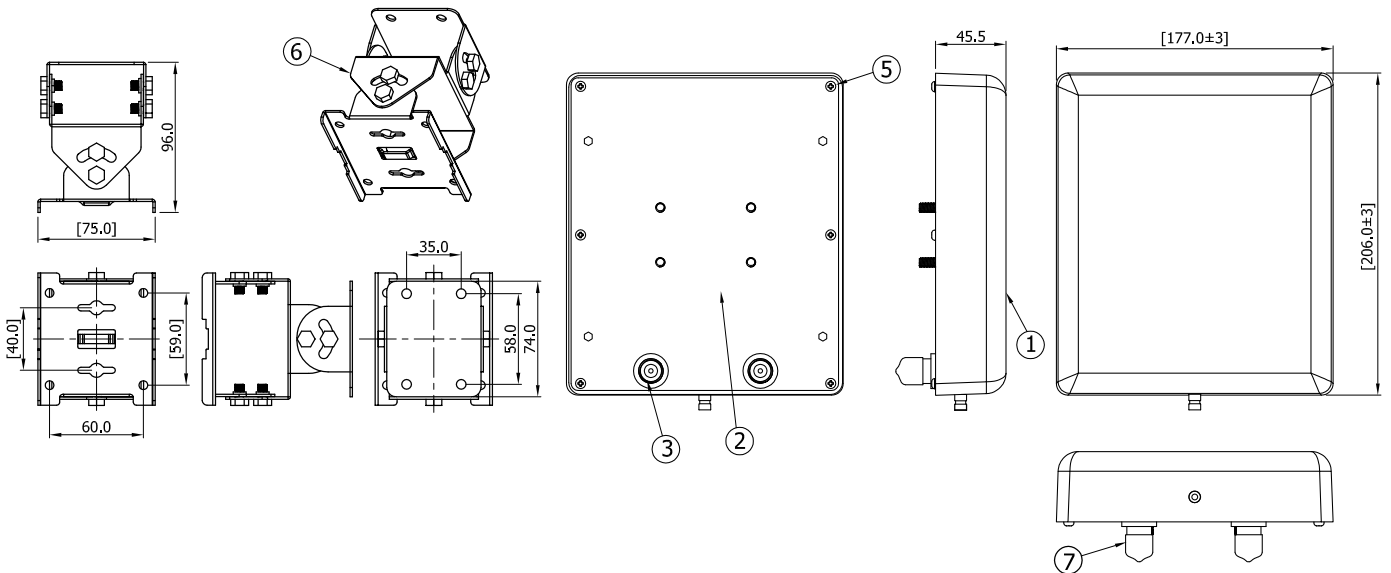

### 3.3 2D Patterns (Port 1)

#### X-Z Plane

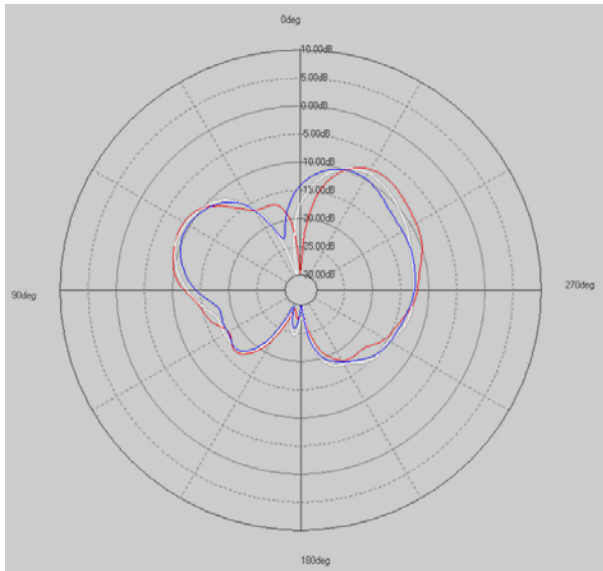

Cross pattern

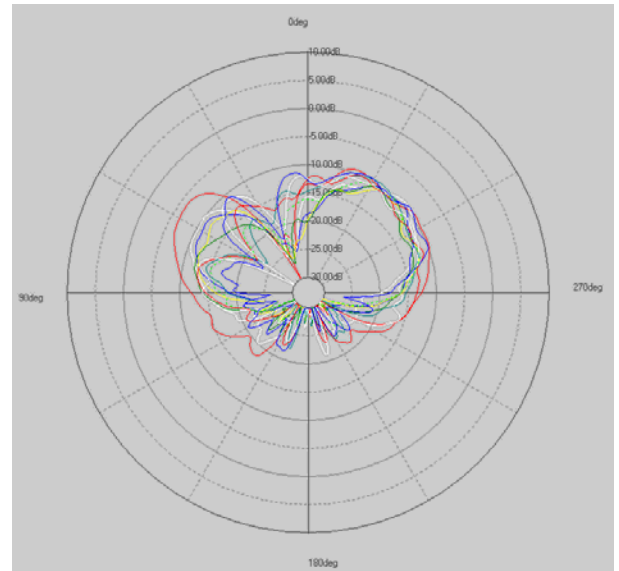
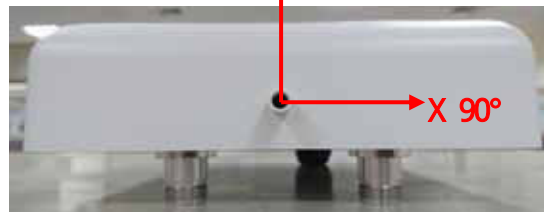

Cross pattern

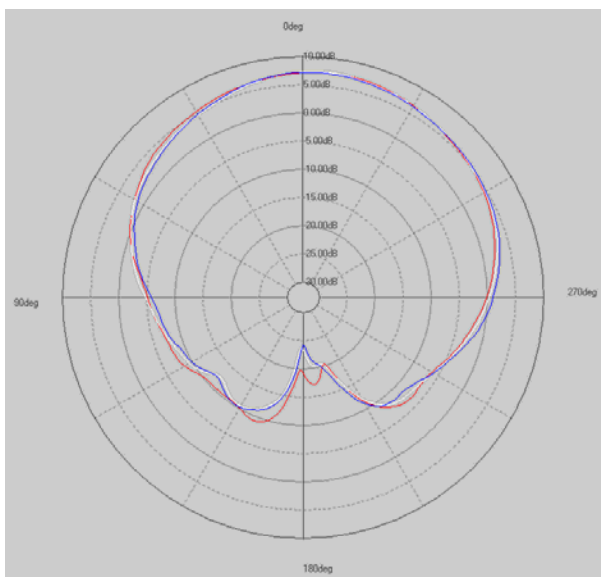
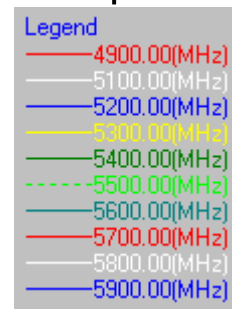

Co pattern

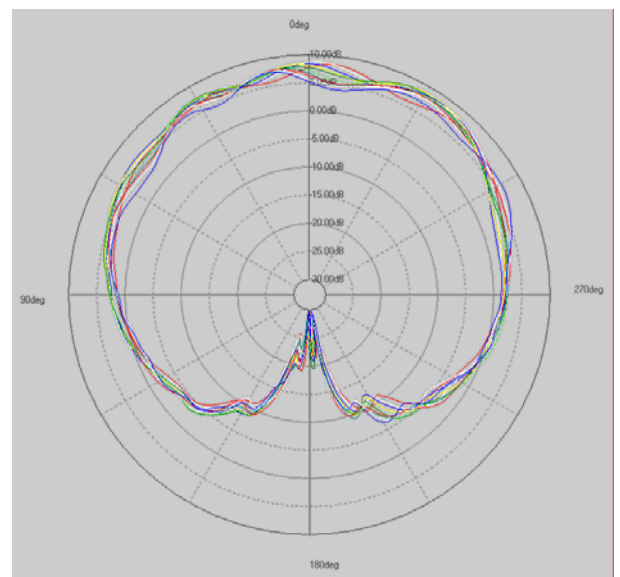

Co pattern

## Y-Z Plane

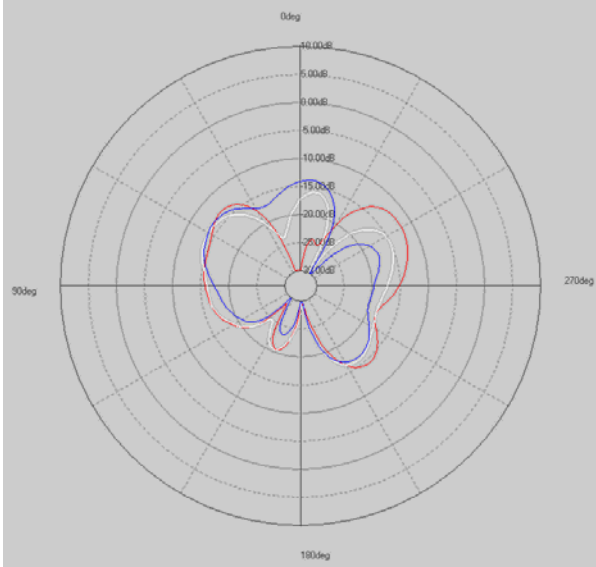

Cross pattern

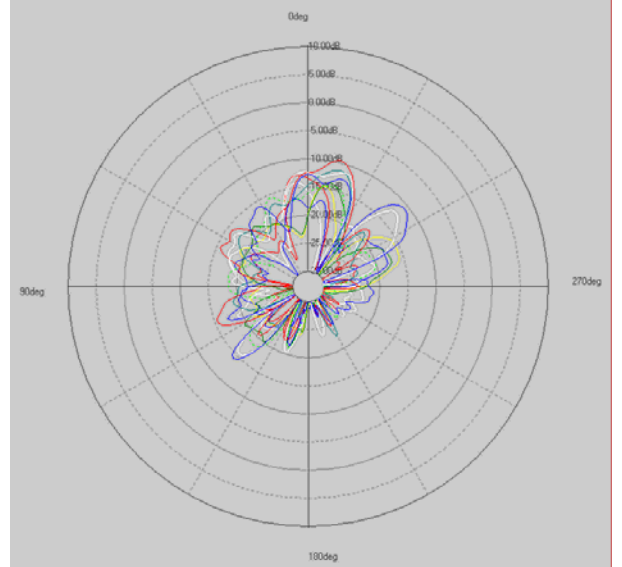
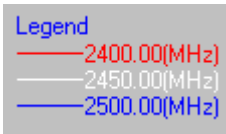

Cross pattern

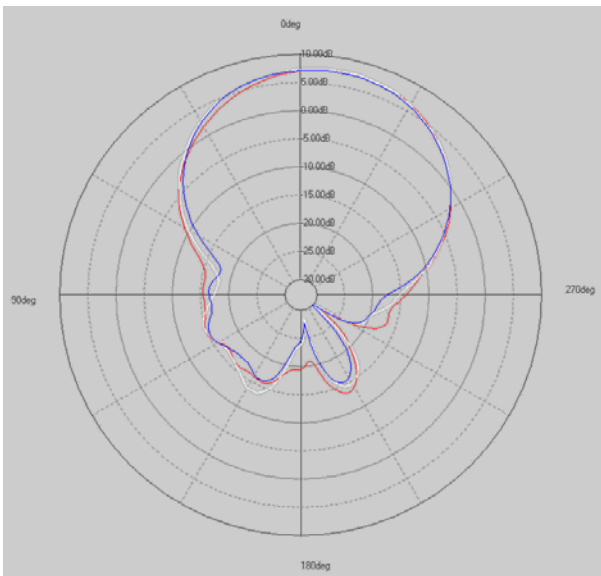
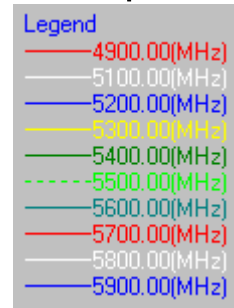

Co pattern

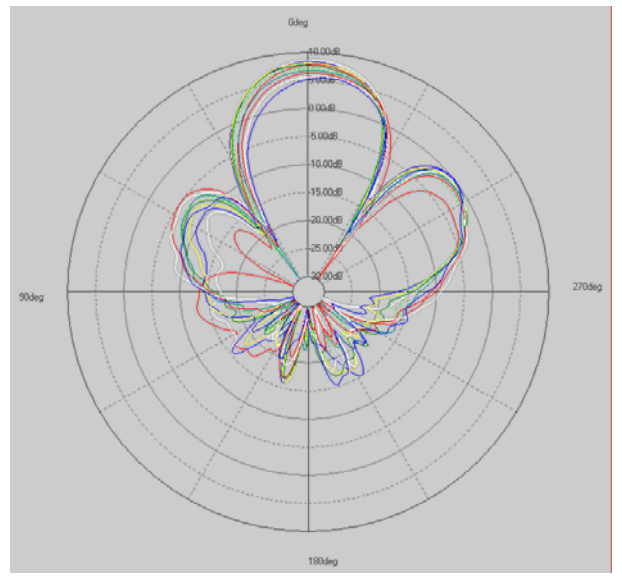

Co pattern

## X-Y Plane

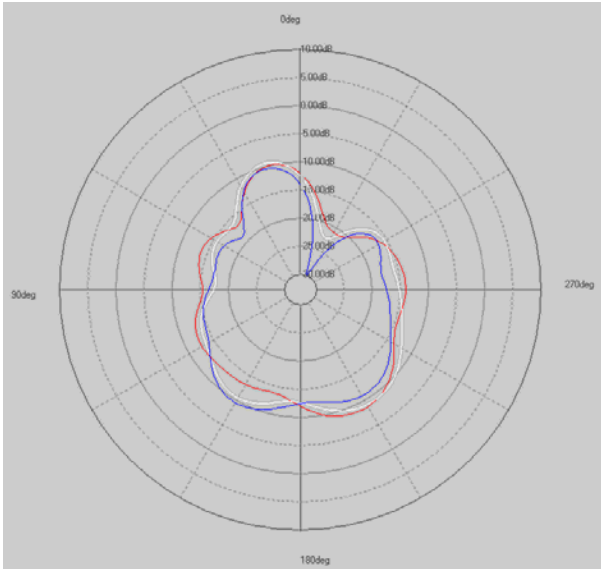

**Cross pattern**

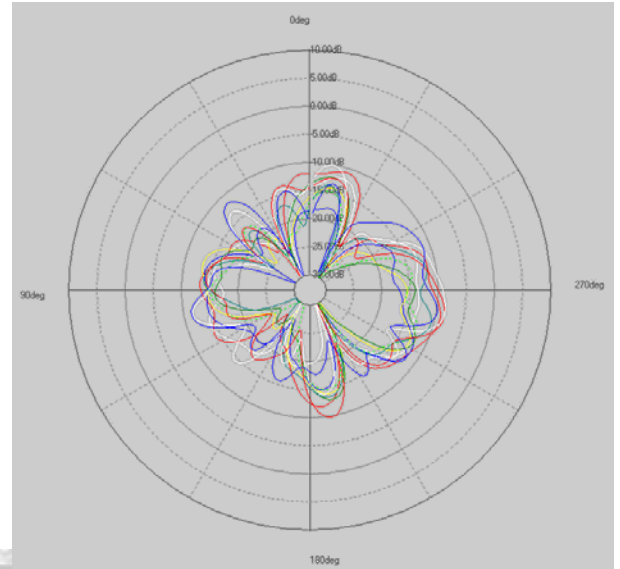
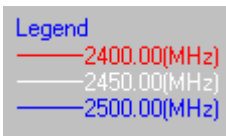

**Cross pattern**

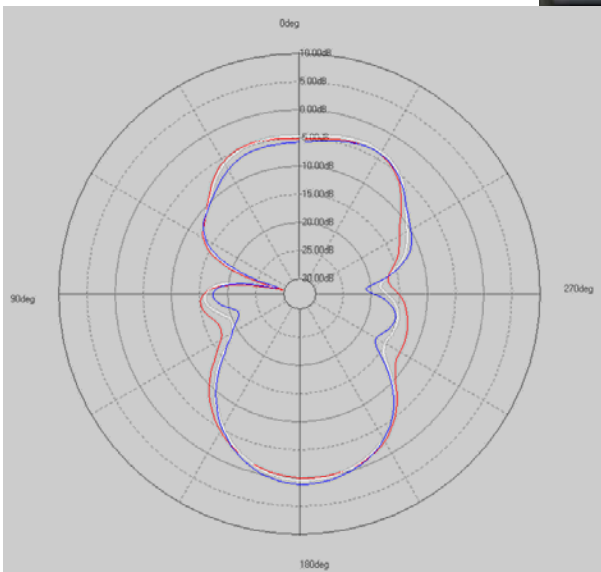
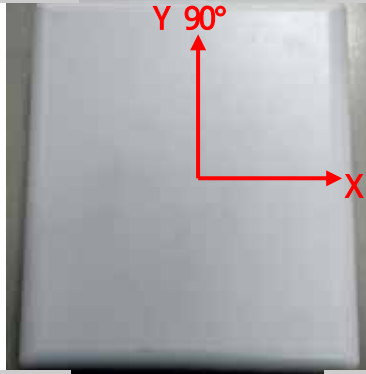
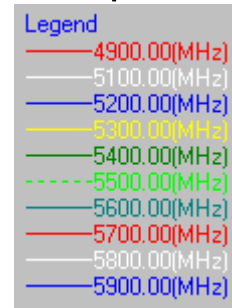

**Co pattern**

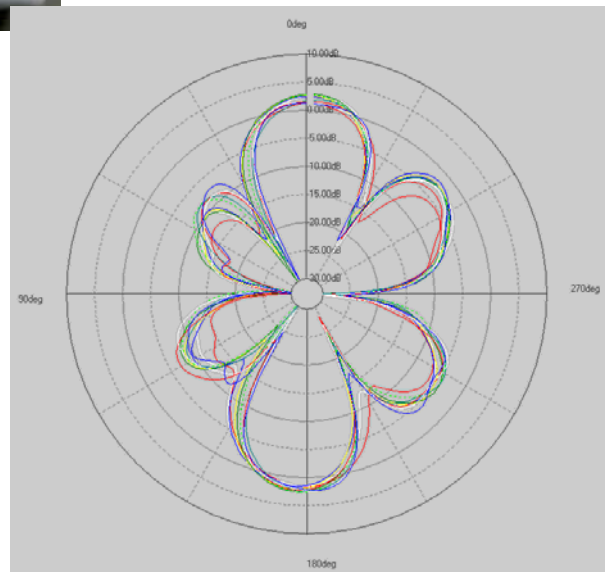

**Co pattern**

### 3.4 2D Patterns (Port 2)

#### X-Z Plane

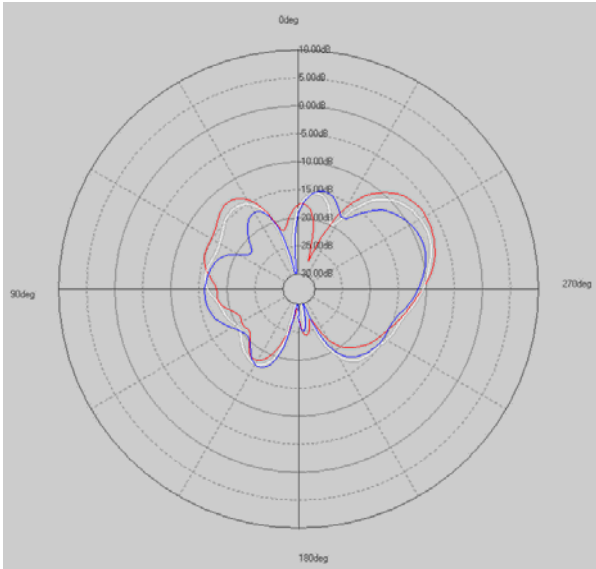

**Cross pattern**

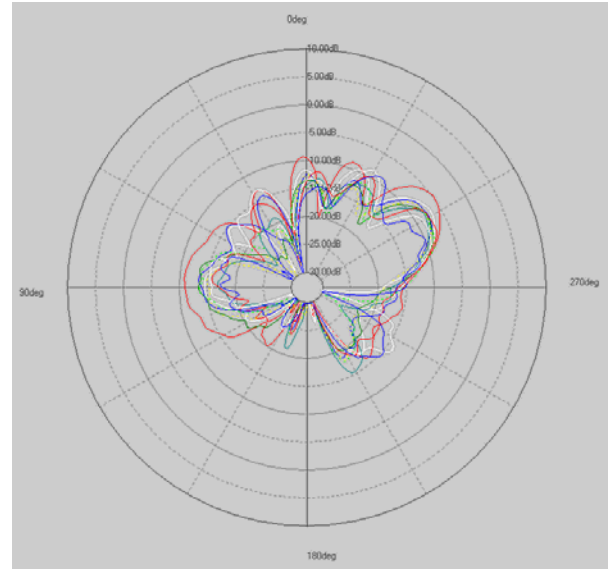
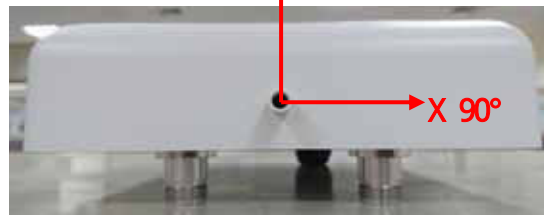
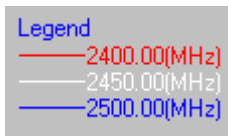

**Cross pattern**

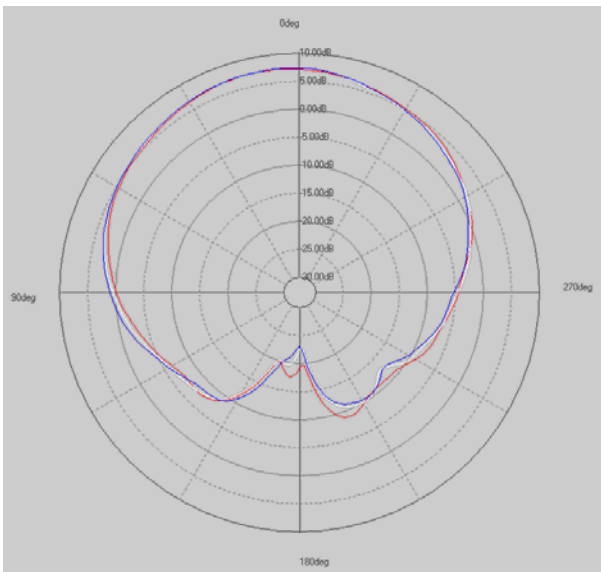
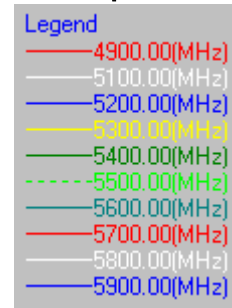

**Co pattern**

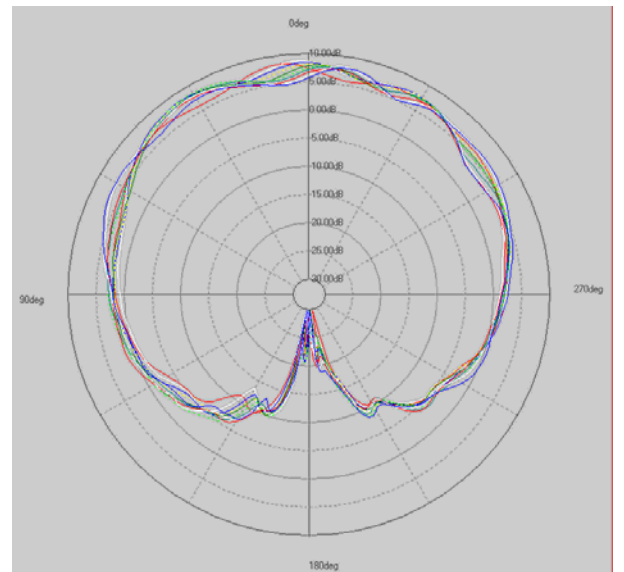

**Co pattern**

## Y-Z Plane

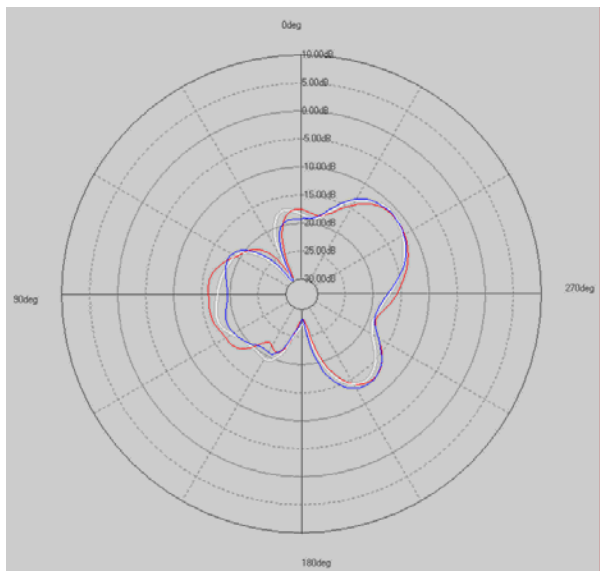

**Cross pattern**

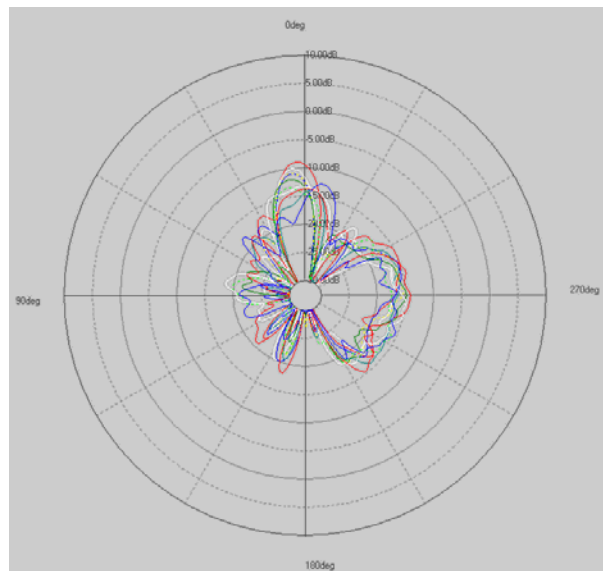
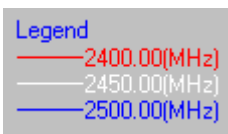

**Cross pattern**

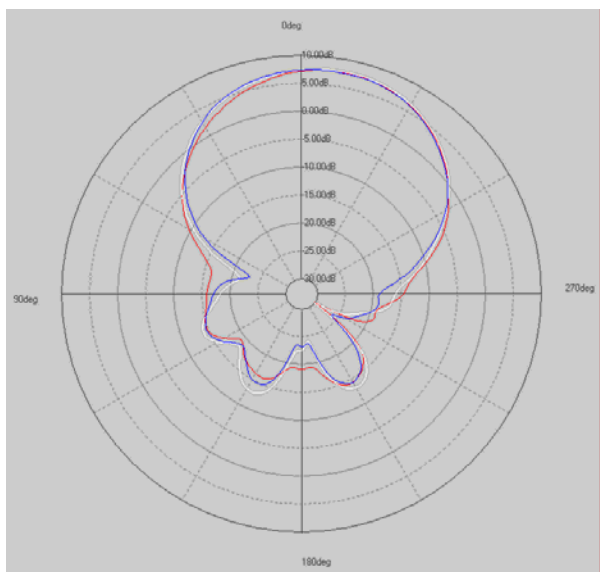
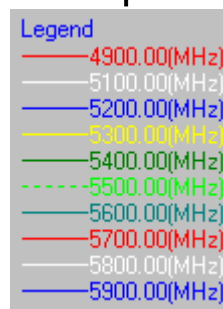

**Co pattern**

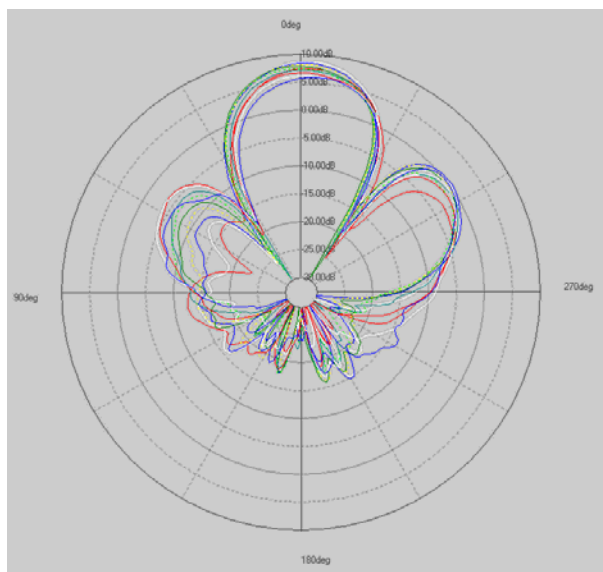

**Co pattern**

## X-Y Plane

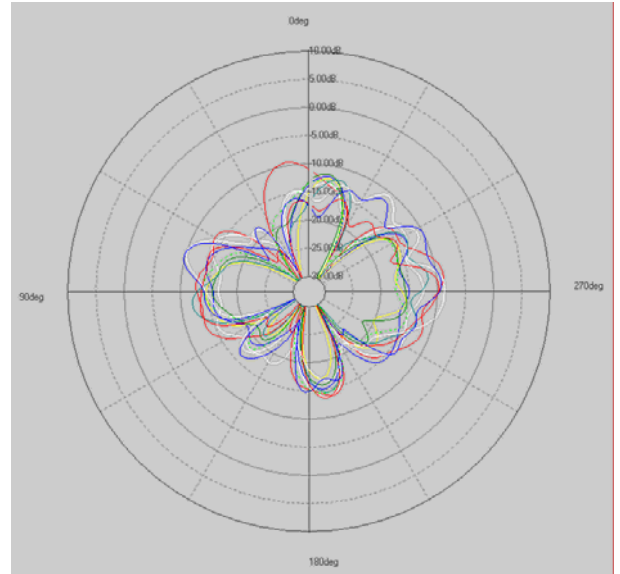
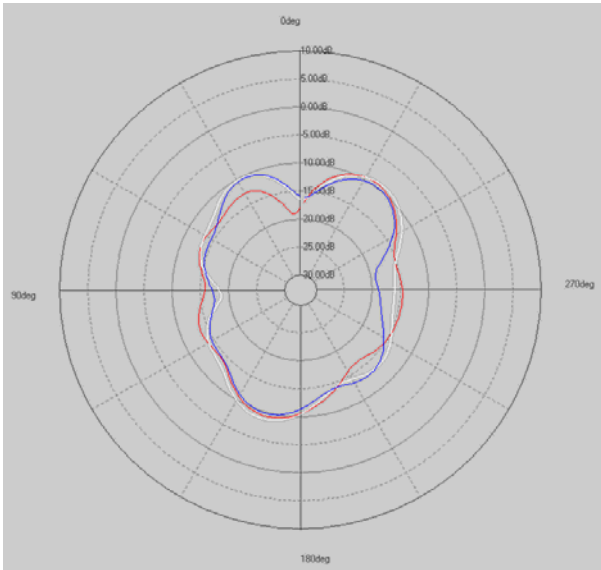

**Cross pattern**

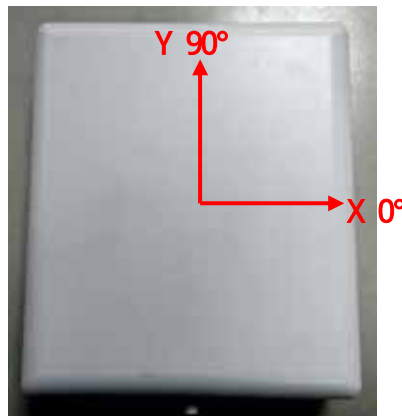
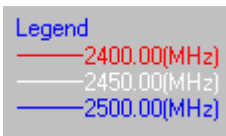

**Cross pattern**

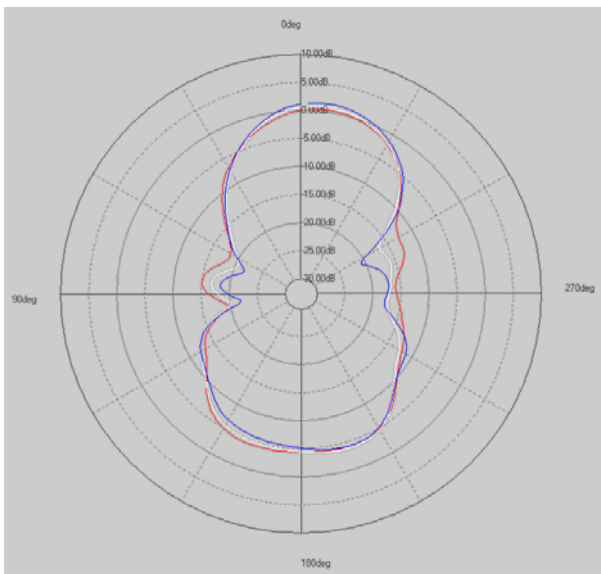
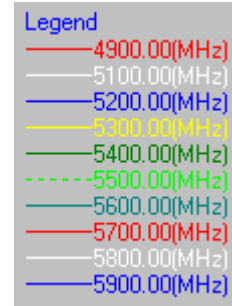

**Co pattern**

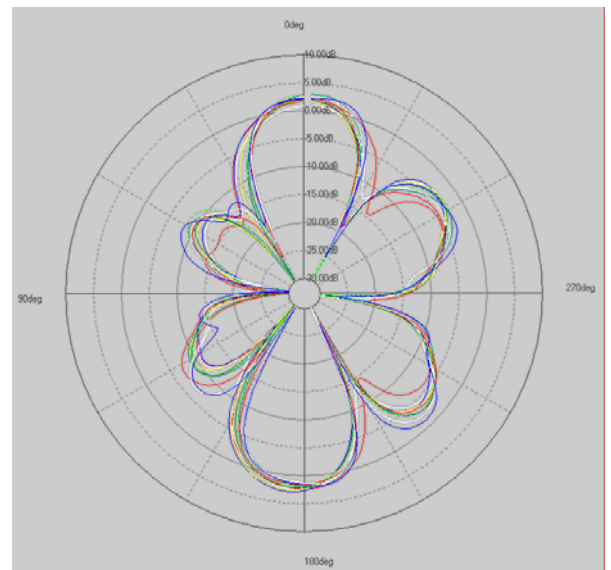

**Co pattern**

Frequency (MHz)	Port 1				Port 2			
	Peak Gain (dBi)	Efficiency	HPBW (deg)		Peak Gain (dBi)	Efficiency	HPBW (deg)	
			Vertical	Horizontal			Vertical	Horizontal
2400	7.63	86%	56	106	7.59	84%	55	107
2450	7.54	86%	61	100	7.61	87%	61	103
2500	7.29	82%	62	104	7.43	84%	61	102
4900	8.52	66%	30	117	8.45	67%	30	119
5100	8.66	71%	30	116	8.65	70%	30	121
5200	8.59	69%	31	119	8.48	71%	30	125
5300	8.77	70%	32	118	8.35	66%	31	122
5400	8.50	69%	33	116	8.32	63%	32	118
5500	8.25	65%	34	111	8.61	67%	33	110
5600	8.36	62%	34	116	8.48	66%	34	111
5700	8.18	64%	33	114	7.86	61%	34	112
5800	7.76	64%	34	118	8.11	67%	35	115
5900	7.53	60%	31	114	7.98	67%	32	114