

## Partial FCC Test Report

### (PART 24)

**Report No.:** RFBBNT-WTW-P21040204A-1

**FCC ID:** SLE-UC8200

**Test Model:** UC-8220-T-LX

**Received Date:** Nov. 30, 2021

**Test Date:** Nov. 30, 2021 ~ Apr. 21, 2022

**Issued Date:** Jun. 24, 2022

**Applicant:** Moxa Inc.

**Address:** No. 1111, Heping Rd., Bade Dist., Taoyuan City 334004, Taiwan

**Issued By:** Bureau Veritas Consumer Products Services (H.K.) Ltd., Taoyuan Branch  
Lin Kou Laboratories

**Lab Address:** No. 47-2, 14th Ling, Chia Pau Vil., Lin Kou Dist., New Taipei City, Taiwan

**Test Location:** No. 70, Wenming Rd., Guishan Dist., Taoyuan City 333, Taiwan (R.O.C.)

**FCC Registration /  
Designation Number:** 281270 / TW0032



This report is governed by, and incorporates by reference, the Conditions of Testing as posted at the date of issuance of this report at <http://www.bureauveritas.com/home/about-us/our-business/cps/about-us/terms-conditions/>, and is intended for your exclusive use. Any copying or replication of this report to or for any other person or entity, or use of our name or trademark, is permitted only with our prior written permission. This report sets forth our findings solely with respect to the test samples identified herein. The results set forth in this report are not indicative or representative of the quality or characteristics of the lot from which a test sample was taken or any similar or identical product unless specifically and expressly noted. Our report includes all of the tests requested by you and the results thereof based upon the information that you provided to us. Measurement uncertainty is only provided upon request for accredited tests. Statements of conformity are based on simple acceptance criteria without taking measurement uncertainty into account, unless otherwise requested in writing. You have 60 days from date of issuance of this report to notify us of any material error or omission caused by our negligence or if you require measurement uncertainty; provided, however, that such notice shall be in writing and shall specifically address the issue you wish to raise. A failure to raise such issue within the prescribed time shall constitute your unqualified acceptance of the completeness of this report, the tests conducted and the correctness of the report contents.

## Table of Contents

<b>Release Control Record .....</b>	<b>3</b>
<b>1 Certificate of Conformity .....</b>	<b>4</b>
<b>2 Summary of Test Results.....</b>	<b>5</b>
2.1 Measurement Uncertainty.....	5
2.2 Test Site and Instruments .....	6
<b>3 General Information .....</b>	<b>7</b>
3.1 General Description of EUT .....	7
3.2 Configuration of System under Test.....	8
3.2.1 Description of Support Units .....	8
3.3 Test Mode Applicability and Tested Channel Detail .....	9
3.4 EUT Operating Conditions .....	9
3.5 General Description of Applied Standards and references.....	9
<b>4 Test Types and Results .....</b>	<b>10</b>
4.1 Radiated Emission Measurement.....	10
4.1.1 Limits of Radiated Emission Measurement .....	10
4.1.2 Test Procedure .....	10
4.1.3 Deviation from Test Standard .....	10
4.1.4 Test Setup.....	11
4.1.5 Test Results .....	12
<b>5 Pictures of Test Arrangements.....</b>	<b>16</b>
<b>Appendix – Information of the Testing Laboratories .....</b>	<b>17</b>

### Release Control Record

Issue No.	Description	Date Issued
RFBNT-WTW-P21040204A-1	Original Release	Jun. 24, 2022

## 1 Certificate of Conformity

**Product:** Arm-based platform  
**Brand:** MOXA  
**Test Model:** UC-8220-T-LX  
**Sample Status:** Engineering Sample  
**Applicant:** Moxa Inc.  
**Test Date:** Nov. 30, 2021 ~ Apr. 21, 2022  
**Standards:** FCC Part 24, Subpart E

The above equipment has been tested by **Bureau Veritas Consumer Products Services (H.K.) Ltd., Taoyuan Branch**, and found compliance with the requirement of the above standards. The test record, data evaluation & Equipment Under Test (EUT) configurations represented herein are true and accurate accounts of the measurements of the sample's RF characteristics under the conditions specified in this report.

**Prepared by :** Gina Liu, **Date:** Jun. 24, 2022  
Gina Liu / Specialist

**Approved by :** Jeremy Lin, **Date:** Jun. 24, 2022  
Jeremy Lin / Project Engineer

## 2 Summary of Test Results

Applied Standard: FCC Part 24 & Part 2			
FCC Clause	Test Item	Result	Remarks
2.1046 24.232	Effective Isotropic Radiated Power	N/A	Refer to Note
2.1047	Modulation Characteristics	N/A	Refer to Note
24.232(d)	Peak to Average Ratio	N/A	Refer to Note
2.1055 24.235	Frequency Stability	N/A	Refer to Note
2.1049	Occupied Bandwidth	N/A	Refer to Note
24.238	Band Edge Measurements	N/A	Refer to Note
2.1051 24.238	Conducted Spurious Emissions	N/A	Refer to Note
2.1053 24.238	Radiated Spurious Emissions	Pass	Meet the requirement of limit. Minimum passing margin is -39.31 dB at 53.28 MHz.

### Note:

1. This report is a partial report, only test item of Radiated Spurious Emissions below 1GHz test was performed for this report. Other testing data please refer to SGS report no.: T190327W11-RP.
2. Determining compliance based on the results of the compliance measurement, not taking into account measurement instrumentation uncertainty.

### 2.1 Measurement Uncertainty

Where relevant, the following measurement uncertainty levels have been estimated for tests performed on the EUT as specified in CISPR 16-4-2:

Measurement	Frequency	Expanded Uncertainty (k=2) ( $\pm$ )
Radiated Emissions up to 1 GHz	9 kHz ~ 30 MHz	3.00 dB
	30 MHz ~ 200 MHz	2.91 dB
	200 MHz ~ 1000 MHz	2.92 dB

## 2.2 Test Site and Instruments

Description & Manufacturer	Model No.	Serial No.	Cal. Date	Cal. Due
Test Receiver Rohde & Schwarz	ESR3	102579	Jul. 05, 2021	Jul. 04, 2022
Spectrum Analyzer KEYSIGHT	N9020B	MY60110462	Dec. 18, 2020	Dec. 17, 2021
			Dec. 21, 2021	Dec. 20, 2022
BILOG Antenna SCHWARZBECK	VULB9168	9168-995	Oct. 28, 2021	Oct. 27, 2022
HORN Antenna SCHWARZBECK	BBHA 9120 D	9120D-404	Nov. 14, 2021	Nov. 13, 2022
HORN Antenna SCHWARZBECK	BBHA 9170	995	Nov. 14, 2021	Nov. 13, 2022
Loop Antenna EMCI	EM-6879	269	Sep. 16, 2021	Sep. 15, 2022
Loop Antenna TESEQ	HLA 6121	45745	Jul. 21, 2021	Jul. 20, 2022
Preamplifier EMCI	EMC330N	980783	Jan. 12, 2021	Jan. 11, 2022
			Jan. 17, 2022	Jan. 16, 2023
Preamplifier EMCI	EMC118A45SE	980810	Jan. 12, 2021	Jan. 11, 2022
			Dec. 30, 2021	Dec. 29, 2022
Preamplifier EMCI	EMC184045SE	980787	Jan. 12, 2021	Jan. 11, 2022
			Jan. 17, 2022	Jan. 16, 2023
RF signal cable EMCI	EMC104-SM-SM- (9000+2000+1000)	201230+ 201242+ 210101	Jan. 12, 2021	Jan. 11, 2022
			Jan. 17, 2022	Jan. 16, 2023
RF signal cable EMCI	EMCCFD400-NM- NM- (9000+300+500)	201252+ 201250+ 201245	Jan. 12, 2021	Jan. 11, 2022
			Jan. 17, 2022	Jan. 16, 2023
RF signal cable EMCI	EMC101G-KM-KM- (5000+3000+2000)	201261+201258+ 201249	Jan. 12, 2021	Jan. 11, 2022
			Jan. 17, 2022	Jan. 16, 2023
Software BV CPS	ADT_Radiated_V7. 6.15.9.5	NA	NA	NA
Turn Table Max-Full	MFT-151SS-0.5T	NA	NA	NA
Turn Table Controller Max-Full	MF-7802BS	MF780208675	NA	NA
Antenna Tower KaiTuo	NA	NA	NA	NA
Antenna Tower Controller KaiTuo	KT-2000	NA	NA	NA
USB Wideband Power Sensor KEYSIGHT	U2021XA	MY55050005/MY55190 004/MY55190007/MY55 210005	Jul. 12, 2021	Jul. 11, 2022

- Note: 1. The calibration interval of the above test instruments is 12 months and the calibrations are traceable to NML/ROC and NIST/USA.  
2. The test was performed in WM Chamber 7.

### 3 General Information

#### 3.1 General Description of EUT

<b>Product</b>	Arm-based platform	
<b>Brand</b>	MOXA	
<b>Test Model</b>	UC-8220-T-LX	
<b>Status of EUT</b>	Engineering Sample	
<b>Power Supply Rating</b>	12Vdc from AC/DC Adapter	
<b>Modulation Type</b>	WCDMA	QPSK
	LTE	QPSK, 16QAM
<b>Frequency Range</b>	WCDMA	1852.4 ~ 1907.6 MHz
	LTE Band 2 (Channel Bandwidth: 1.4 MHz)	1850.7 ~ 1909.3 MHz
	LTE Band 2 (Channel Bandwidth: 3 MHz)	1851.5 ~ 1908.5 MHz
	LTE Band 2 (Channel Bandwidth: 5 MHz)	1852.5 ~ 1907.5 MHz
	LTE Band 2 (Channel Bandwidth: 10 MHz)	1855.0 ~ 1905.0 MHz
	LTE Band 2 (Channel Bandwidth: 15 MHz)	1857.5 ~ 1902.5 MHz
	LTE Band 2 (Channel Bandwidth: 20 MHz)	1860.0 ~ 1900.0 MHz
<b>Antenna Type</b>	Dipole Antenna with 2 dBi gain	
<b>Accessory Device</b>	N/A	
<b>Data Cable Supplied</b>	N/A	

Note:

1. This report is prepared for FCC class II permissive change. The difference compared with the original report (SGS report no.: T190327W11-RP) are changing duplexer (Band13), PA (Band17) and Firmware/Software update.

For change in duplexer and PA, it is meet section III. D of KDB 178919 D01 v06 requirements,

- The new chip component is pin-for-pin compatible.
- The new chip has the same basic function as the old chip.
- No change in radio parameters has occurred.

For Firmware/Software update, it is not impact in RF characteristics, for more detail please refer to operation description exhibit.

After engineering judgement, for WCDMA and LTE Band 2, only test item of radiated spurious emissions test was performed for this report. Other testing data please refer to original test report.

2. The above Antenna information is declared by manufacturer and for more detailed features description, please refer to the manufacturer's specifications, the laboratory shall not be held responsible.
3. The above EUT information is declared by manufacturer and for more detailed features description, please refers to the manufacturer's specifications or user's manual.

### 3.2 Configuration of System under Test

#### <Radiated Emission Test>

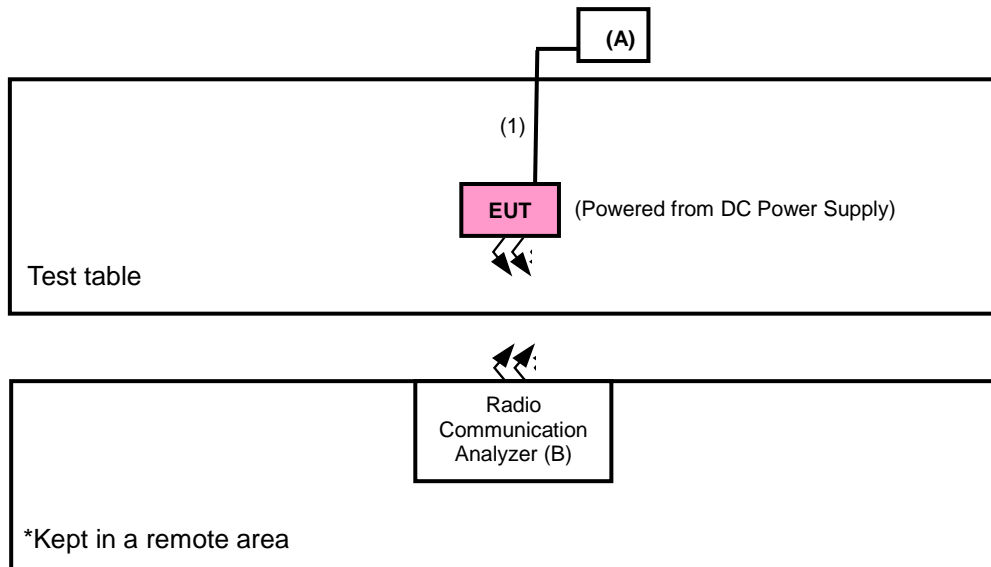

#### 3.2.1 Description of Support Units

The EUT has been tested as an independent unit together with other necessary accessories or support units. The following support units or accessories were used to form a representative test configuration during the tests.

No.	Product	Brand	Model No.	Serial No.	FCC ID
A	DC Power Supply	Topward	6306D	809760	NA
B	Radio Communication Analyzer	Anritsu	MT8820C	6201010284	NA

No.	Signal Cable Description Of The Above Support Units
1.	Power Cable: 1.8m

Note:

1. All power cords of the above support units are non-shielded (1.8m).



### 3.3 Test Mode Applicability and Tested Channel Detail

Pre-Scan has been conducted to determine the worst-case mode from all possible combinations between available modulations, data rates, XYZ axis, and antenna ports. The worst case was found when positioned on X-plane for LTE Band 2 according to original report.

#### WCDMA

EUT Configure Mode	Test Item	Available Channel	Tested Channel	Mode
-	Radiated Emission	9262 to 9538	9400	WCDMA

#### LTE Band 2

EUT Configure Mode	Test Item	Available Channel	Tested Channel	Channel Bandwidth	Modulation	Mode
-	Radiated Emission	18607 to 19193	19193	1.4 MHz	QPSK	1 RB / 0 RB Offset

#### Test Condition:

Test Item	Environmental Conditions	Input Power	Tested By
Radiated Emission	22 deg. C, 67 % RH	120 Vac, 60 Hz	Wade Huang, Luis Lee

### 3.4 EUT Operating Conditions

The EUT makes a call to the communication simulator. The communication simulator station system controlled a EUT to export maximum output power under transmission mode and specific channel frequency

### 3.5 General Description of Applied Standards and references

The EUT is a RF Product. According to the specifications of the manufacturer, it must comply with the requirements of the following standards and references:

#### Test Standard:

FCC 47 CFR Part 2

FCC 47 CFR Part 24

ANSI 63.26-2015

**NOTE:** All test items have been performed and recorded as per the above standards.

#### References Test Guidance:

KDB 971168 D01 Power Meas License Digital Systems v03r01

ANSI/TIA/EIA-603-E 2016

**NOTE:** All test items have been performed as a reference to the above KDB test guidance.

## 4 Test Types and Results

### 4.1 Radiated Emission Measurement

#### 4.1.1 Limits of Radiated Emission Measurement

The power of any emission outside of the authorized operating frequency ranges must be attenuated below the transmitting power (P) by a factor of at least  $43 + 10 \log(P)$  dB. The emission limit is equal to -13 dBm.

#### 4.1.2 Test Procedure

- a. In the semi-anechoic chamber, EUT placed on the 0.8m(below or equal 1GHz) and/or 1.5m(above 1GHz) height of Turn Table, rotated the table around 360 degrees to search the maximum radiation power and receiver antenna shall be rotated vertical and horizontal polarization and moved height from 1m to 4m to find the maximum polar radiated power. The "Read Value" is the spectrum reading the maximum power value.
- b. The height of antenna is varied from one meter to four meters above the ground to determine the maximum value of the field strength. Both horizontal and vertical polarizations of the antenna are set to make the measurement.
- c. Perform a field strength measurement and record the worse read value, is the field strength value via a spectrum reading obtained corrected for antenna factor, cable loss and pre-amplifier factor and then mathematically convert the measured field strength level to EIRP/ERP level.
- d. Following C63.26 section 5.5 and 5.2.7
  - $EIRP (dBm) = E (dB\mu V/m) + 20\log(D) - 104.8$ ; where D is the measurement distance (in the far field region) in m.
  - $ERP (dBm) = E (dB\mu V/m) + 20\log(D) - 104.8 - 2.15$ ; where D is the measurement distance (in the far field region) in m.

#### Note:

1. The resolution bandwidth and video bandwidth of test receiver/spectrum analyzer is 1MHz/3MHz.
2. The emission levels were against the limit of frequency range 9 kHz ~ 30 MHz:  
The amplitude of spurious emissions attenuated more than 20 dB below the permissible value is not required to be report.

#### 4.1.3 Deviation from Test Standard

No deviation.

4.1.4 Test Setup

<Radiated Emission below or equal 1 GHz>

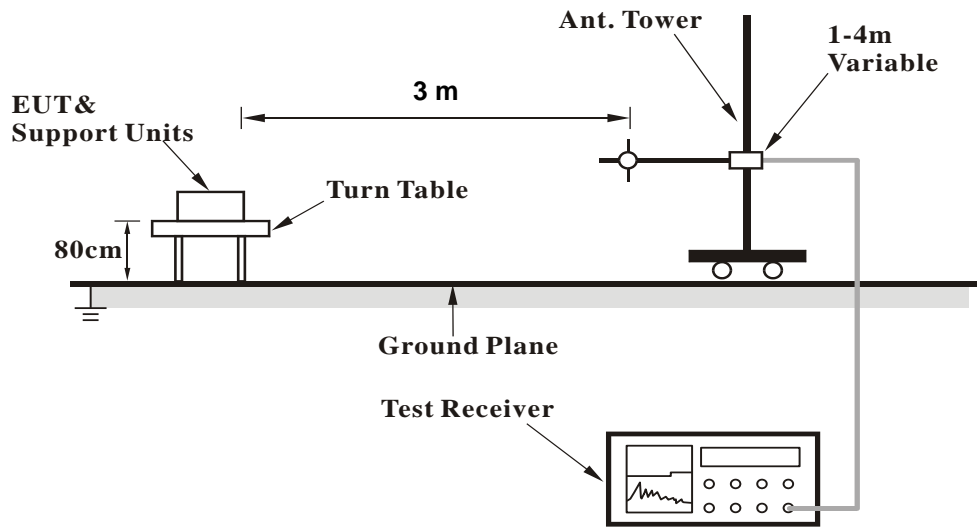

<Radiated Emission above 1 GHz>

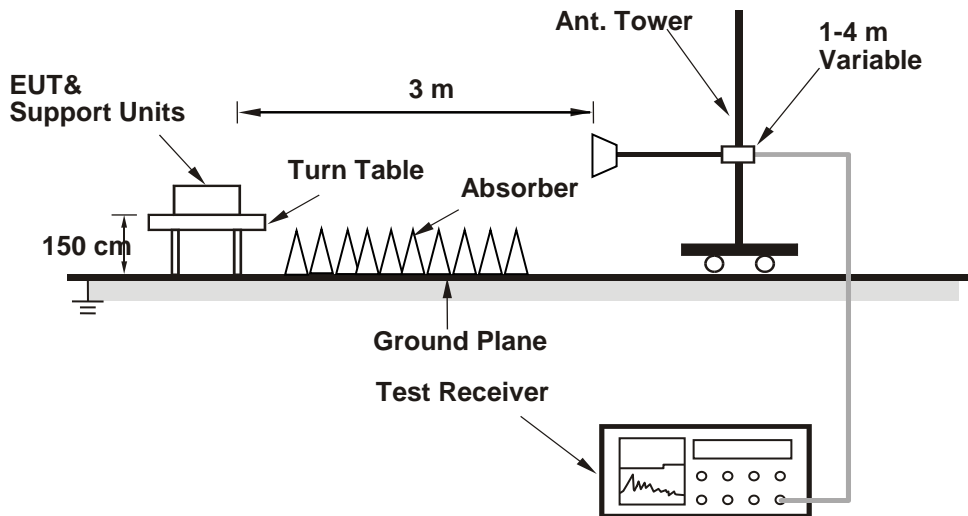

For the actual test configuration, please refer to the attached file (Test Setup Photo).

4.1.5 Test Results  
Below 1GHz  
WCDMA II

Mode	TX channel 9400 (1880MHz)	Frequency Range	Below 1000 MHz
Environmental Conditions	22deg. C, 67%RH	Input Power	120Vac, 60Hz
Tested By	Luis Lee		

Antenna Polarity & Test Distance : Horizontal at 3 m								
No	Frequency (MHz)	EIRP (dBm)	Limit (dBm)	Margin (dB)	Antenna Height (m)	Table Angle (Degree)	Raw Value (dBuV)	Correction Factor (dB/m)
1	78.50	-61.40	-13.00	-48.40	1.99 H	179	57.30	-118.70
2	159.98	-68.00	-13.00	-55.00	1.49 H	17	45.50	-113.50
3	301.60	-67.30	-13.00	-54.30	1.01 H	167	46.10	-113.40
4	353.01	-68.30	-13.00	-55.30	1.01 H	165	43.90	-112.20
5	584.84	-65.90	-13.00	-52.90	1.49 H	350	40.90	-106.80
6	624.61	-62.20	-13.00	-49.20	1.49 H	70	43.80	-106.00

**Remarks:**

1.  $EIRP(dBm) = Raw\ Value(dBuV) + Correction\ Factor(dB/m)$
2.  $Correction\ Factor(dB/m) = Antenna\ Factor(dB/m) + Cable\ Factor(dB) - Pre-Amplifier\ Factor(dB) + 20\log(D) - 104.8$
3. Margin value = EIRP – Limit value
4. The other EIRP levels were very low against the limit.

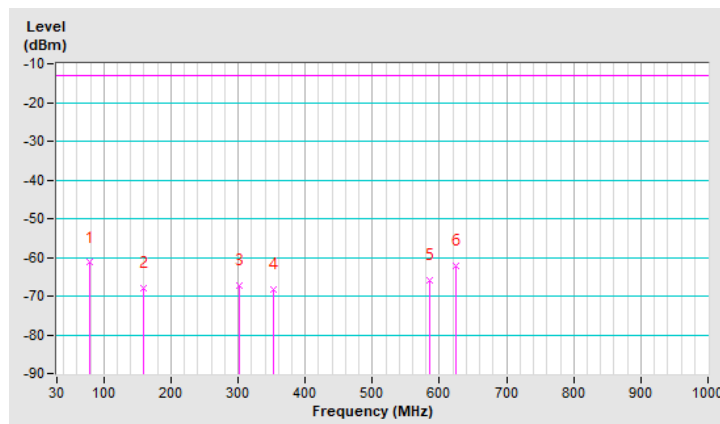

Mode	TX channel 9400 (1880MHz)	Frequency Range	Below 1000 MHz
Environmental Conditions	22deg. C, 67%RH	Input Power	120Vac, 60Hz
Tested By	Luis		

Antenna Polarity & Test Distance : Vertical at 3m								
No	Frequency (MHz)	EIRP (dBm)	Limit (dBm)	Margin (dB)	Antenna Height (m)	Table Angle (Degree)	Raw Value (dBuV)	Correction Factor (dB/m)
1	64.92	-56.40	-13.00	-43.40	1.01 V	270	59.30	-115.70
2	128.94	-69.60	-13.00	-56.60	1.01 V	147	45.30	-114.90
3	296.75	-70.00	-13.00	-57.00	1.51 V	124	43.50	-113.50
4	373.38	-70.50	-13.00	-57.50	1.01 V	199	40.90	-111.40
5	518.88	-66.60	-13.00	-53.60	1.51 V	134	41.60	-108.20
6	746.83	-63.30	-13.00	-50.30	1.99 V	125	40.60	-103.90

**Remarks:**

1.  $EIRP(dBm) = Raw\ Value(dBuV) + Correction\ Factor(dB/m)$
2.  $Correction\ Factor(dB/m) = Antenna\ Factor(dB/m) + Cable\ Factor(dB) - Pre-Amplifier\ Factor(dB) + 20\log(D) - 104.8$
3.  $Margin\ value = EIRP - Limit\ value$
4. The other EIRP levels were very low against the limit.

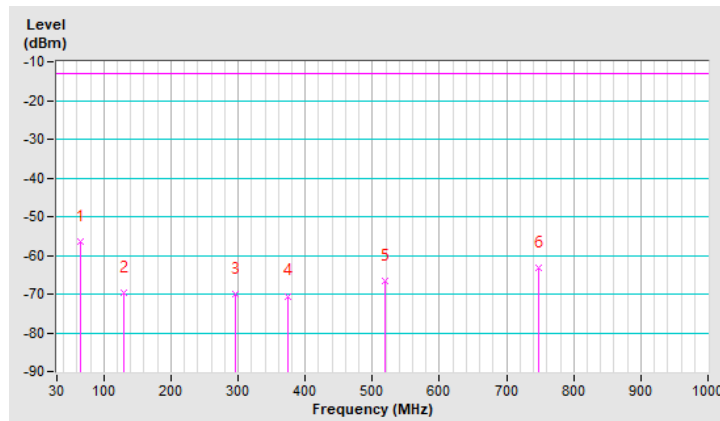

LTE Band 2, Channel Bandwidth: 1.4MHz

Mode	TX channel 19193 (1909.30MHz)	Frequency Range	Below 1000 MHz
Environmental Conditions	22deg. C, 67%RH	Input Power	120Vac, 60Hz
Tested By	Wade Huang		

Antenna Polarity & Test Distance : Horizontal at 3 m								
No	Frequency (MHz)	EIRP (dBm)	Limit (dBm)	Margin (dB)	Antenna Height (m)	Table Angle (Degree)	Raw Value (dBUV)	Correction Factor (dB/m)
1	52.31	-62.12	-13.00	-49.12	1.49 H	132	51.89	-114.01
2	68.80	-57.35	-13.00	-44.35	1.99 H	166	58.88	-116.23
3	138.64	-63.58	-13.00	-50.58	1.99 H	160	50.36	-113.94
4	236.61	-65.89	-13.00	-52.89	1.49 H	18	49.63	-115.52
5	322.94	-63.62	-13.00	-50.62	1.01 H	328	48.96	-112.58
6	421.88	-64.71	-13.00	-51.71	1.99 H	236	45.48	-110.19

**Remarks:**

1.  $EIRP(dBm) = Raw\ Value(dBuV) + Correction\ Factor(dB/m)$
2.  $Correction\ Factor(dB/m) = Antenna\ Factor(dB/m) + Cable\ Factor(dB) - Pre-Amplifier\ Factor(dB) + 20\log(D) - 104.8$
3.  $Margin\ value = EIRP - Limit\ value$
4. The other EIRP levels were very low against the limit.

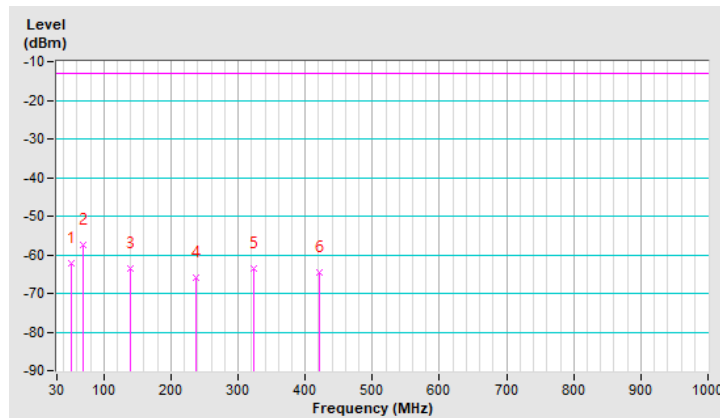

Mode	TX channel 19193 (1909.30MHz)	Frequency Range	Below 1000 MHz
Environmental Conditions	22deg. C, 67%RH	Input Power	120Vac, 60Hz
Tested By	Wade Huang		

Antenna Polarity & Test Distance : Vertical at 3m								
No	Frequency (MHz)	EIRP (dBm)	Limit (dBm)	Margin (dB)	Antenna Height (m)	Table Angle (Degree)	Raw Value (dBUV)	Correction Factor (dB/m)
1	53.28	-52.31	-13.00	-39.31	1.01 V	347	61.75	-114.06
2	143.49	-67.37	-13.00	-54.37	1.01 V	127	46.28	-113.65
3	209.45	-67.99	-13.00	-54.99	1.01 V	311	49.26	-117.25
4	237.58	-70.41	-13.00	-57.41	1.51 V	248	45.04	-115.45
5	333.61	-67.43	-13.00	-54.43	1.51 V	230	44.86	-112.29
6	428.67	-67.80	-13.00	-54.80	1.51 V	149	42.21	-110.01

**Remarks:**

1.  $EIRP(dBm) = Raw\ Value(dBuV) + Correction\ Factor(dB/m)$
2.  $Correction\ Factor(dB/m) = Antenna\ Factor(dB/m) + Cable\ Factor(dB) - Pre-Amplifier\ Factor(dB) + 20\log(D) - 104.8$
3.  $Margin\ value = EIRP - Limit\ value$
4. The other EIRP levels were very low against the limit.

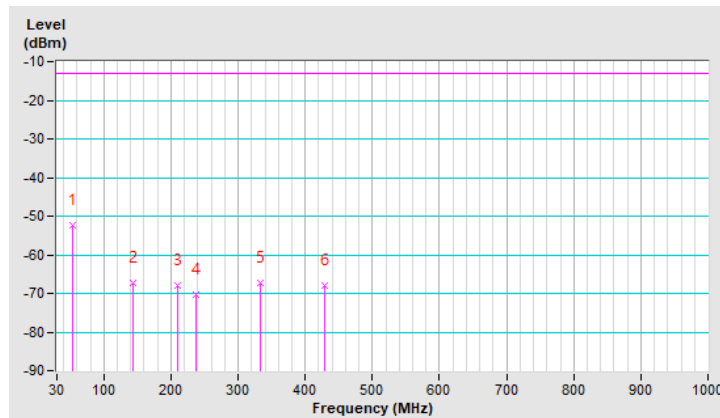

## 5 Pictures of Test Arrangements

Please refer to the attached file (Test Setup Photo).



## Appendix – Information of the Testing Laboratories

We, Bureau Veritas Consumer Products Services (H.K.) Ltd., Taoyuan Branch, were founded in 1988 to provide our best service in EMC, Radio, Telecom and Safety consultation. Our laboratories are FCC recognized accredited test firms and accredited according to ISO/IEC 17025.

If you have any comments, please feel free to contact us at the following:

**Lin Kou EMC/RF Lab**

Tel: 886-2-26052180

Fax: 886-2-26051924

**Hsin Chu EMC/RF/Telecom Lab**

Tel: 886-3-6668565

Fax: 886-3-6668323

**Hwa Ya EMC/RF/Safety Lab**

Tel: 886-3-3183232

Fax: 886-3-3270892

**Email:** [service.adt@tw.bureauveritas.com](mailto:service.adt@tw.bureauveritas.com)

**Web Site:** [www.bureauveritas-adt.com](http://www.bureauveritas-adt.com)

The address and road map of all our labs can be found in our web site also.

--- END ---