

FCC Test Report

Product Name	Wireless AP / Bridge / Client
Model No	AWK-3121B-xx-yy-z xx = US or JP or EU or blank yy = CT or blank z = T followed (KS-01) or blank, dash can be blank if without xx, yy, z
FCC ID	SLE-AWK-3121B

Applicant	Moxa Inc.
Address	No. 1111, Heping Rd., Bade Dist., Taoyuan City 334004, Taiwan

Date of Receipt	May 21, 2022
Issue Date	Dec. 07, 2022
Report No.	2250634R-RFUSWL2V01-A
Report Version	V2.0

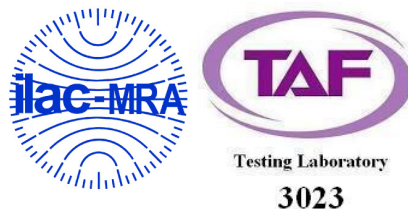

The test results relate only to the samples tested.

The test results shown in the test report are traceable to the national/international standard through the calibration report of the equipment and evaluated measurement uncertainty herein.

This report must not be used to claim product endorsement by TAF or any agency of the government.

The test report shall not be reproduced without the written approval of DEKRA Testing and Certification Co., Ltd.

Measurement uncertainties evaluated for each testing system and associated connections are given here to provide the system information for reference. Compliance determinations do not take into account measurement uncertainties for each testing system, but are based on the results of the compliance measurement.

Test Report

Issue Date: Dec. 07, 2022

Report No.: 2250634R-RFUSWL2V01-A



Product Name	Wireless AP / Bridge / Client
Applicant	Moxa Inc.
Address	No. 1111, Heping Rd., Bade Dist., Taoyuan City 334004, Taiwan
Manufacturer	Moxa Inc.
Model No.	AWK-3121B-xx-yy-z xx = US or JP or EU or blank yy = CT or blank z = T followed (KS-01) or blank, dash can be blank if without xx, yy, z
FCC ID	SLE-AWK-3121B
EUT Rated Voltage	DC 24V
EUT Test Voltage	DC 24V
Trade Name	KYOSAN
Applicable Standard	FCC CFR Title 47 Part 15 Subpart C ANSI C63.4: 2014, ANSI C63.10: 2013
Test Result	Complied

Documented By :

Jinn Chen

(Supervisor / Jinn Chen)

Tested By :

Ivan Chuang

(Senior Engineer / Ivan Chuang)

Approved By :

Alan Chen

(Senior Engineer / Alan Chen)

TABLE OF CONTENTS

Description	Page
1. GENERAL INFORMATION	6
1.1. EUT Description.....	6
1.2. Tested System Details.....	9
1.3. Configuration of Tested System	9
1.4. EUT Exercise Software	9
1.5. Test Facility	10
1.6. List of Test Item and Equipment	11
1.7. Uncertainty	12
2. Conducted Emission.....	13
2.1. Test Setup	13
2.2. Limits	13
2.3. Test Procedure	13
2.4. Test Result of Conducted Emission.....	14
3. Peak Power Output	15
3.1. Test Setup	15
3.2. Limits	15
3.3. Test Procedure	15
3.4. Test Result of Peak Power Output.....	16
4. Radiated Emission	28
4.1. Test Setup	28
4.2. Limits	29
4.3. Test Procedure	30
4.4. Test Result of Radiated Emission.....	32
5. RF antenna conducted test.....	42
5.1. Test Setup	42
5.2. Limits	42
5.3. Test Procedure	42
5.4. Test Result of RF antenna conducted test.....	43
6. Band Edge	49
6.1. Test Setup	49
6.2. Limits	50
6.3. Test Procedure	50
6.4. Test Result of Band Edge	52
7. 6dB Bandwidth	64
7.1. Test Setup	64
7.2. Limits	64
7.3. Test Procedure	64
7.4. Test Result of 6dB Bandwidth.....	65
8. Power Density	71
8.1. Test Setup	71

8.2.	Limits	71
8.3.	Test Procedure	71
8.4.	Test Result of Power Density	72
9.	Duty Cycle	78
9.1.	Test Setup	78
9.2.	Test Procedure	78
9.3.	Test Result of Duty Cycle.....	79
10.	EMI Reduction Method During Compliance Testing	82

Appendix 1: EUT Test Photographs

Appendix 2: Product Photos-Please refer to the file: 2250634R-Product Photos

Revision History

Report No.	Version	Description	Issued Date
2250634R-RFUSWL2V01-A	V1.0	Initial issue of report.	Aug. 17, 2022
2250634R-RFUSWL2V01-A	V2.0	Modify product name, model number, trade name and EUT Rated Voltage.	Dec. 07, 2022

1. GENERAL INFORMATION

1.1. EUT Description

Product Name	Wireless AP / Bridge / Client
Trade Name	KYOSAN
Model No.	AWK-3121B-xx-yy-z xx = US or JP or EU or blank yy = CT or blank z = T followed (KS-01) or blank, dash can be blank if without xx, yy, z
Test Sample	AWK-3121B-US-CT-T (KS-01)
FCC ID	SLE-AWK-3121B
Frequency Range	802.11g: 2412-2462MHz
Number of Channels	802.11g: 11CH
Data Rate	802.11g: 6-54Mbps
Channel Separation	802.11g: 5MHz
Type of Modulation	802.11g: OFDM, BPSK, QPSK, 16QAM, 64QAM
Channel Bandwidth	5/10/20MHz
Antenna Type	Dipole Antenna, Panel Antenna
Antenna Gain	Refer to the table "Antenna List"
Channel Control	Auto

Antenna List

No.	Manufacturer	Part No.	Antenna Type	Peak Gain
1	MOXA	ANT-WDB-ANM-0306	Dipole Antenna	3.80dBi for 2.4 GHz
2	MOXA	ANT-WDB-ANM-0502	Dipole Antenna	4.62dBi for 2.4 GHz
3	MOXA	MAT-WDB-PA-NF-2-0708	Panel Antenna	7.63dBi for 2.4 GHz
4	MOXA	ANT-WDB-PNF-1011	Panel Antenna	11.0dBi for 2.4 GHz
5	MOXA	ANT-WDB-ONM-0707	Dipole Antenna	7.10dBi for 2.4 GHz
6	MOXA	ANT-WDB-ONF-0709	Dipole Antenna	7.40dBi for 2.4 GHz
7	MOXA	ANT-WSB-PNF-12-02	Panel Antenna	12.34dBi for 2.4 GHz

Note:

- 1.The antenna of EUT is conforming to FCC 15.203.
- 2.Each antenna has been evaluated and only the worst case (higher gain antenna) is presented in the report.

802.11g-5/10/20MHz Center Frequency of Each Channel:

Channel	Frequency	Channel	Frequency	Channel	Frequency	Channel	Frequency
Channel 01:	2412 MHz	Channel 02:	2417 MHz	Channel 03:	2422 MHz	Channel 04:	2427 MHz
Channel 05:	2432 MHz	Channel 06:	2437 MHz	Channel 07:	2442 MHz	Channel 08:	2447 MHz
Channel 09:	2452 MHz	Channel 10:	2457 MHz	Channel 11:	2462 MHz		

Note:

1. The EUT is a Wireless AP / Bridge / Client with built-in WLAN (802.11g) transceiver.
2. This is to request a Class II permissive change.

The major change filed under this application is:

Change #1: The different of each model is shown as below:

Model Name	Model Differences
AWK-3121B-EU-CT-T (KS-01)	For Marketing Purpose
AWK-3121B-US-CT-T (KS-01)	For Marketing Purpose
AWK-3121B-JP-CT-T (KS-01)	For Marketing Purpose

Change #2: Modify product name, model number, trade name and EUT Rated Voltage.

3. Regarding to the operation frequency, the lowest, middle and highest frequency are selected to perform the test.
4. Lowest and highest data rates are tested in each mode. Only worst case is shown in the report.
5. These tests are conducted on a sample for the purpose of demonstrating compliance of transmitter with Part 15 Subpart C Paragraph 15.247 of spread spectrum devices.

Test Mode	Mode 1: SISO A Transmit (802.11g 6Mbps)_5M
	Mode 2: SISO A Transmit (802.11g 6Mbps)_10M
	Mode 3: SISO A Transmit (802.11g 6Mbps)_20M
	Mode 4: SISO B Transmit (802.11g 6Mbps)_5M
	Mode 5: SISO B Transmit (802.11g 6Mbps)_10M
	Mode 6: SISO B Transmit (802.11g 6Mbps)_20M

1.2. Summary of Test Item

Test Condition			Test Item					
			Conducted				Radiated Emission	
Antenna No.	Antenna Type	Antenna Gain	Conducted Power	Power Density	Occupied Bandwidth	Conducted Emission (20dBc)	Radiated Emission	Band Edge
1	Dipole	3.80 dBi						
2	Dipole	4.62 dBi						
3	Panel	7.63 dBi						
4	Panel	11.0 dBi						
5	Dipole	7.10 dBi						
6	Dipole	7.40 dBi	✓	✓	✓	✓	✓	✓
7	Panel	12.34 dBi	✓	✓	✓	✓	✓	✓

Note:

1. Transmitting antennas of directional gain greater than 6 dBi, the conducted output power from the intentional radiator shall be reduced below the limit.
2. Used exclusively for fixed, point-to-point operations the maximum conducted output power of the intentional radiator is reduced by 1 dB for every 3 dB that the directional gain of the antenna exceeds 6 dBi.

1.3. Tested System Details

The types for all equipment, plus descriptions of all cables used in the tested system (including inserted cards) are:

Product	Manufacturer	Model No.	Serial No.	Power Cord
1 Power Adapter	MW	GS60A24	N/A	N/A
2 Notebook PC	ASUS	P2438U	H1NXCV11U083025	N/A

Signal Cable Type	Signal cable Description
A Power Cable	Non-shielded, 2m
B Power Cable	Non-shielded, 1.7m
C LAN Cable	Shielded, 2m

1.4. Configuration of Tested System

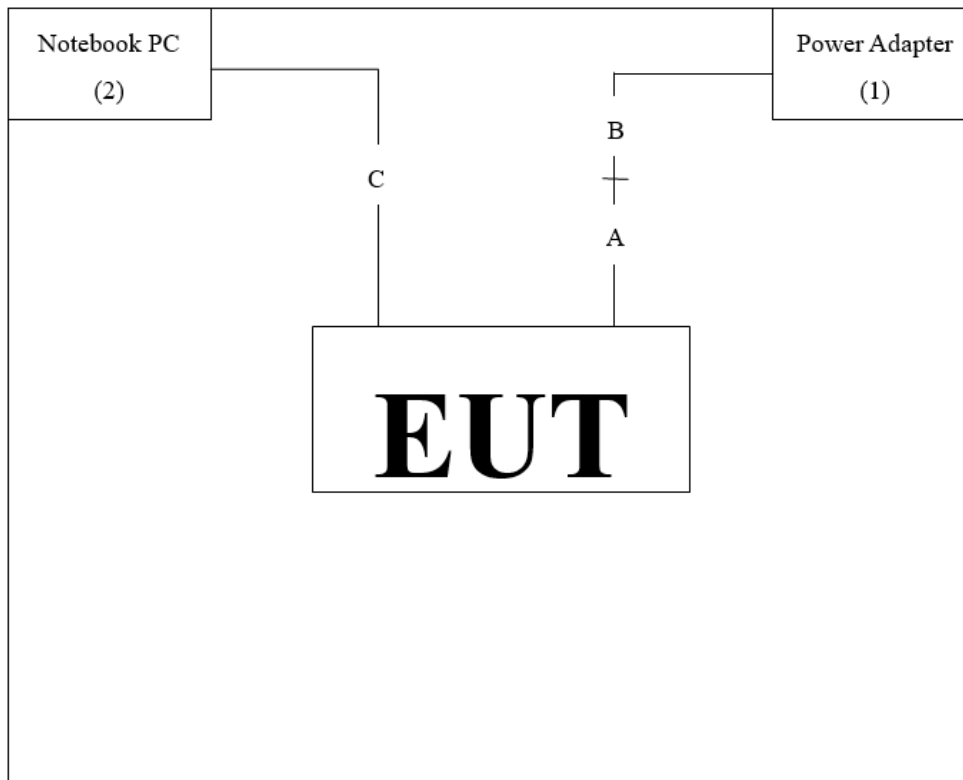

1.5. EUT Exercise Software

1. Setup the EUT as shown in Section 1.4.
2. Execute software “Google Chrome Version 103.0.5060.134” on the EUT.
3. Configure the test mode, the test channel, and the data rate.
4. Press “OK” to start the continuous Transmit.
5. Verify that the EUT works properly.

1.6. Test Facility

Ambient conditions in the laboratory:

Performed Item	Items	Required	Actual
Conducted Emission	Temperature (°C)	10~40 °C	27.3°C
	Humidity (%RH)	10~90 %	51.7%
Radiated Emission	Temperature (°C)	10~40 °C	24.2°C
	Humidity (%RH)	10~90 %	59.4%
Conductive	Temperature (°C)	10~40 °C	22°C
	Humidity (%RH)	10~90 %	55%

USA : FCC Registration Number: TW0033

Canada : CAB Identifier Number: TW3023 / Company Number: 26930

Site Description : Accredited by TAF
Accredited Number: 3023

Test Laboratory : DEKRA Testing and Certification Co., Ltd
Address : No. 5-22, Ruishukeng Linkou District, New Taipei City,
24451, Taiwan

Performed Location : No. 26, Huaya 1st Rd., Guishan Dist., Taoyuan City
333411, Taiwan, R.O.C.

Phone Number : +886-3-275-7255
Fax Number : +886-3-327-8031
Email Address : info.tw@dekra.com
Website : <http://www.dekra.com.tw>

1.7. List of Test Item and Equipment

For Conducted measurements /HY-SR01

	Equipment	Manufacturer	Model No.	Serial No.	Cal. Date	Due Date
X	EMI Test Receiver	R&S	ESR7	101601	2022.06.23	2023.06.22
X	Two-Line V-Network	R&S	ENV216	101306	2022.05.23	2023.05.22
	Two-Line V-Network	R&S	ENV216	101307	2022.07.04	2023.07.03
X	Coaxial Cable	SUHNER	RG400_BNC	RF001	2022.05.24	2023.05.23

Note:

1. All equipments are calibrated every one year.
2. The test instruments marked with "X" are used to measure the final test results.
3. Test Software version : E3 210616 dekra V9.

For Conducted measurements /HY-SR02

	Equipment	Manufacturer	Model No.	Serial No.	Cal. Date	Due Date
X	Spectrum Analyzer	R&S	FSV40	101895	2022.03.07	2023.03.06
X	Spectrum Analyzer	KEYSIGHT	N9010A	MY55150401	2021.09.11	2022.09.10
X	Peak Power Analyzer	KEYSIGHT	8900B	MY51000539	2022.05.27	2023.05.26
X	Power Sensor	KEYSIGHT	N1923A	MY59240002	2022.05.19	2023.05.18
X	Power Sensor	KEYSIGHT	N1923A	MY59240003	2022.05.19	2023.05.18

Note:

1. All equipments are calibrated every one year.
2. The test instruments marked with "X" are used to measure the final test results.
3. Test Software version : DEKRA Conduction Test System V9.0.5.

For Radiated measurements / HY-CB02

	Equipment	Manufacturer	Model No.	Serial No.	Cal. Date	Due Date
X	Loop Antenna	AMETEK	HLA6121	49611	2022.03.18	2023.03.17
X	Bi-Log Antenna	SCHWARZBECK	VULB9168	9168-675	2021.08.10	2022.08.09
X	Horn Antenna	RF SPIN	DRH18-E	210503A18ES	2022/06/08	2023/06/07
X	Horn Antenna	Com-Power	AH-840	101100	2021.10.04	2022.10.03
X	Pre-Amplifier	SGH	SGH0301-9	20211007-11	2022.02.22	2023.02.21
X	Pre-Amplifier	EMCI	EMC051845SE	980632	2021.09.07	2022.09.06
X	Pre-Amplifier	EMCI	EMC05820SE	980361	2021.12.16	2022.12.15
	Pre-Amplifier	EMCI	EMC184045SE	980369		
X	Coaxial Cable	EMCI	EMC102-KM-KM-600	1160314	2022.05.12	2023.05.11
	Coaxial Cable	EMCI	EMC102-KM-KM-7000	170242		
X	Filter	MICRO TRONICS	BRM50702	G251	2021.09.16	2022.09.15
	Filter	MICRO TRONICS	BRM50716	G188	2021.09.16	2022.09.15
X	Spectrum Analyzer	R&S	FSV3044	101113	2022.01.25	2023.02.24
X	EMI Test Receiver	R&S	ESR	102793	2021.12.15	2022.12.14
	Coaxial Cable	SGH	HA800	GD20110223-2		
X	Coaxial Cable	SGH	HA800	GD20110222-4	2022.03.17	2023.03.16
	Coaxial Cable	SGH	SGH18	2021005-2		
	Coaxial Cable	SGH	SGH18	202108-5		

Note:

1. All equipments are calibrated every one year.
2. The test instruments marked with "X" are used to measure the final test results.
3. Test Software version : E3 210616 dekra V9.

1.8. Uncertainty

Uncertainties have been calculated according to the DEKRA internal document.

The reported expanded uncertainties are based on a standard uncertainty multiplied by a coverage factor of $k=2$, providing a level of confidence of approximately 95%.

Measurement uncertainties evaluated for each testing system and associated connections are given here to provide the system information for reference. Compliance determinations do not take into account measurement uncertainties for each testing system, but are based on the results of the compliance measurement.

Test item	Uncertainty	
Conducted Emission	±3.42 dB	
Peak Power Output	±0.89 dB	
Radiated Emission	Under 1GHz ±4.05 dB	Above 1GHz ±3.73 dB
RF Antenna Conducted Test	±2.06 dB	
Band Edge	Under 1GHz ±4.05 dB	Above 1GHz ±3.73 dB
6dB Bandwidth	±1544.74 Hz	
Power Density	±2.06 dB	
Duty Cycle	±2.31 ms	

2. Conducted Emission

2.1. Test Setup

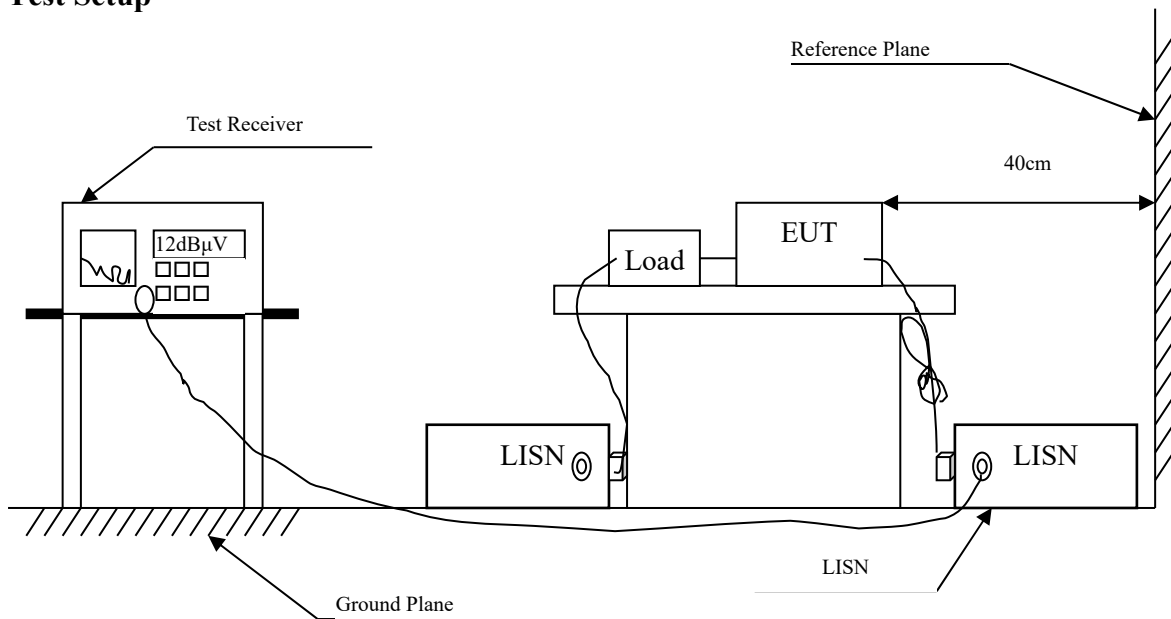

2.2. Limits

FCC Part 15 Subpart C Paragraph 15.207 (dB μ V) Limit		
Frequency MHz	Limits	
	QP	AVG
0.15 - 0.50	66-56	56-46
0.50-5.0	56	46
5.0 - 30	60	50

2.3. Test Procedure

The EUT and simulators are connected to the main power through a line impedance stabilization network (L.I.S.N.). This provides a 50 ohm /50uH coupling impedance for the measuring equipment. The peripheral devices are also connected to the main power through a LISN that provides a 50ohm /50uH coupling impedance with 50ohm termination. (Please refers to the block diagram of the test setup and photographs.)

Both sides of A.C. line are checked for maximum conducted interference. In order to find the maximum emission, the relative positions of equipment and all of the interface cables must be changed according to ANSI C63.4: 2014 on conducted measurement.

Conducted emissions were investigated over the frequency range from 0.15MHz to 30MHz using a receiver bandwidth of 9kHz.

2.4. Test Result of Conducted Emission

SISO A_Dipole

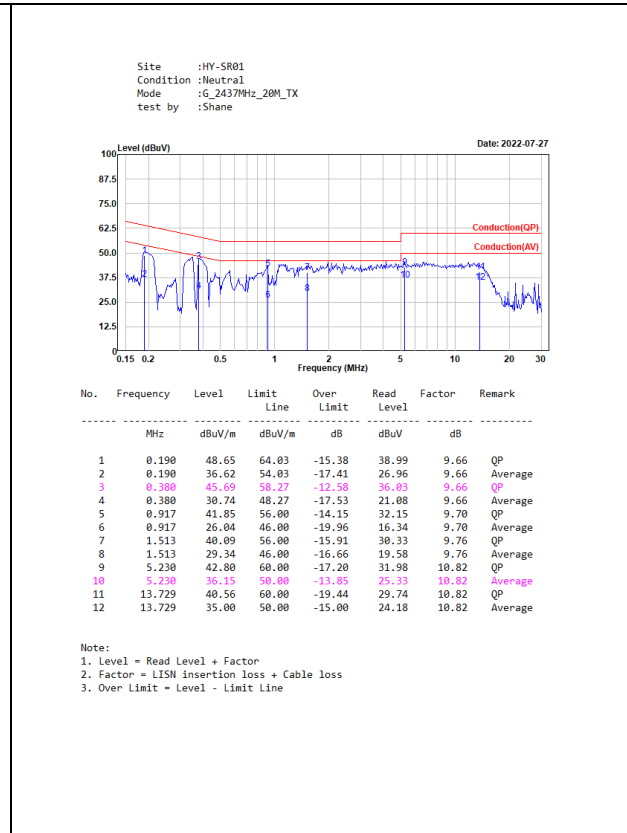
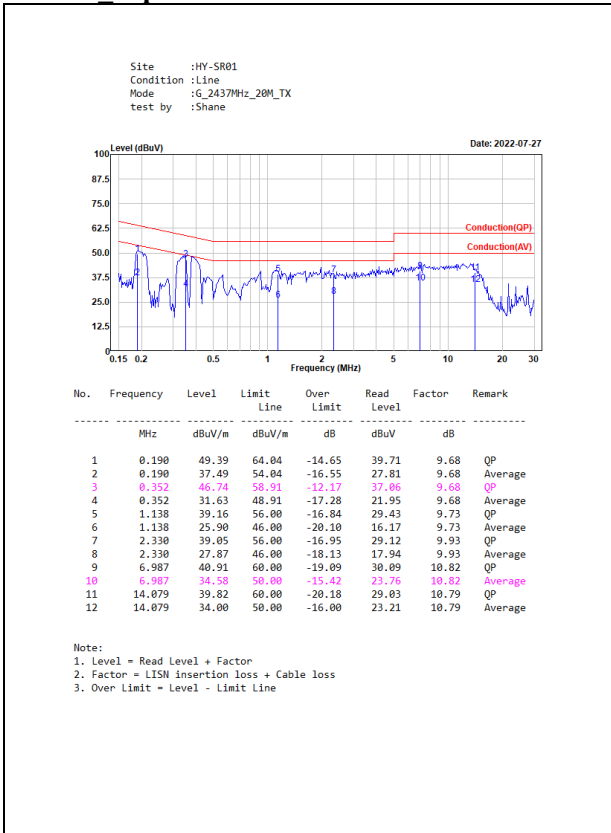

SISO A_Panel

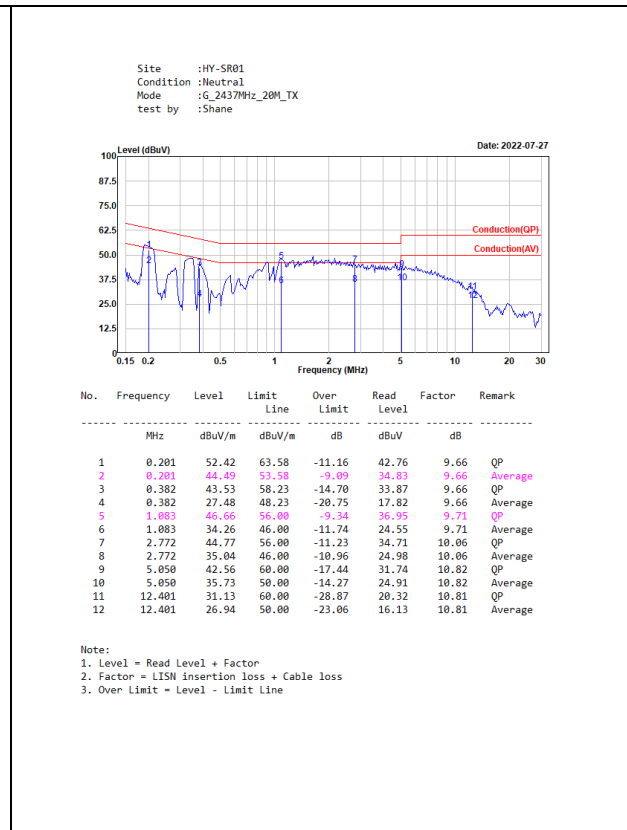
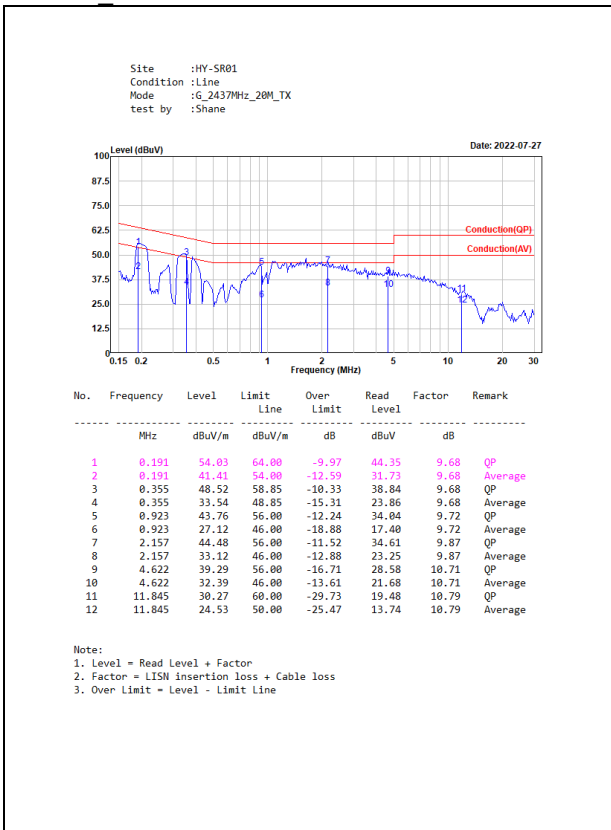

3. Peak Power Output

3.1. Test Setup



3.2. Limits

The maximum peak power shall be less 1 Watt.

3.3. Test Procedure

The EUT was tested according to C63.10:2013 for compliance to FCC 47CFR 15.247 requirements. The maximum peak conducted output power using C63.10:2013 Section 11.9.1.3 PKPM1 Peak power meter method. The maximum average conducted output power using C63.10:2013 Section 11.9.2.3 Measurement using a power meter (PM). (Measurement using a gated RF average-reading power meter).

3.4. Test Result of Peak Power Output

Product : Wireless AP / Bridge / Client
Test Item : Peak Power Output Data
Test Mode : Mode 1: SISO A Transmit (802.11g 6Mbps)_5M_Dipole
Test Date : 2022/06/06

Channel No.	Frequency (MHz)	Data Rate (Mbps)	Power (dBm)	Limit (dBm)	Result
1	2412	6	25.60	28.6	Pass
6	2437	6	25.12	28.6	Pass
11	2462	6	25.88	28.6	Pass

Note: Peak Power Output Value =Reading value on power meter + cable loss

Product : Wireless AP / Bridge / Client
Test Item : Peak Power Output Data
Test Mode : Mode 2: SISO A Transmit (802.11g 6Mbps)_10M_Dipole
Test Date : 2022/06/06

Channel No.	Frequency (MHz)	Data Rate (Mbps)	Power (dBm)	Limit (dBm)	Result
1	2412	6	25.25	28.6	Pass
6	2437	6	25.49	28.6	Pass
11	2462	6	25.50	28.6	Pass

Note: Peak Power Output Value =Reading value on power meter + cable loss

Product : Wireless AP / Bridge / Client
Test Item : Peak Power Output Data
Test Mode : Mode 3: SISO A Transmit (802.11g 6Mbps)_20M_Dipole
Test Date : 2022/06/06

Channel No.	Frequency (MHz)	Data Rate (Mbps)	Power (dBm)	Limit (dBm)	Result
1	2412	6	25.84	28.6	Pass
6	2437	6	25.85	28.6	Pass
11	2462	6	25.68	28.6	Pass

Note: Peak Power Output Value = Reading value on power meter + cable loss

Product : Wireless AP / Bridge / Client
Test Item : Peak Power Output Data
Test Mode : Mode 4: SISO B Transmit (802.11g 6Mbps)_5M_Dipole
Test Date : 2022/06/06

Channel No.	Frequency (MHz)	Data Rate (Mbps)	Power (dBm)	Limit (dBm)	Result
1	2412	6	25.59	28.6	Pass
6	2437	6	25.03	28.6	Pass
11	2462	6	25.79	28.6	Pass

Note: Peak Power Output Value = Reading value on power meter + cable loss

Product : Wireless AP / Bridge / Client
Test Item : Peak Power Output Data
Test Mode : Mode 5: SISO B Transmit (802.11g 6Mbps)_10M_Dipole
Test Date : 2022/06/06

Channel No.	Frequency (MHz)	Data Rate (Mbps)	Power (dBm)	Limit (dBm)	Result
1	2412	6	25.21	28.6	Pass
6	2437	6	24.59	28.6	Pass
11	2462	6	24.92	28.6	Pass

Note: Peak Power Output Value =Reading value on power meter + cable loss

Product : Wireless AP / Bridge / Client
Test Item : Peak Power Output Data
Test Mode : Mode 6: SISO B Transmit (802.11g 6Mbps)_20M_Dipole
Test Date : 2022/06/06

Channel No.	Frequency (MHz)	Data Rate (Mbps)	Power (dBm)	Limit (dBm)	Result
1	2412	6	25.83	28.6	Pass
6	2437	6	25.69	28.6	Pass
11	2462	6	25.62	28.6	Pass

Note: Peak Power Output Value = Reading value on power meter + cable loss

Product : Wireless AP / Bridge / Client
Test Item : Peak Power Output Data
Test Mode : Mode 1: SISO A Transmit (802.11g 6Mbps)_5M_Panel
Test Date : 2022/06/06

Channel No.	Frequency (MHz)	Data Rate (Mbps)	Power (dBm)	Limit (dBm)	Result
1	2412	6	25.60	28	Pass
6	2437	6	25.12	28	Pass
11	2462	6	25.88	28	Pass

Note: Peak Power Output Value = Reading value on power meter + cable loss

Product : Wireless AP / Bridge / Client
Test Item : Peak Power Output Data
Test Mode : Mode 2: SISO A Transmit (802.11g 6Mbps)_10M_Panel
Test Date : 2022/06/06

Channel No.	Frequency (MHz)	Data Rate (Mbps)	Power (dBm)	Limit (dBm)	Result
1	2412	6	25.25	28	Pass
6	2437	6	25.49	28	Pass
11	2462	6	25.50	28	Pass

Note: Peak Power Output Value =Reading value on power meter + cable loss

Product : Wireless AP / Bridge / Client
Test Item : Peak Power Output Data
Test Mode : Mode 3: SISO A Transmit (802.11g 6Mbps)_20M_Panel
Test Date : 2022/06/06

Channel No.	Frequency (MHz)	Data Rate (Mbps)	Power (dBm)	Limit (dBm)	Result
1	2412	6	25.84	28	Pass
6	2437	6	25.85	28	Pass
11	2462	6	25.68	28	Pass

Note: Peak Power Output Value = Reading value on power meter + cable loss

Product : Wireless AP / Bridge / Client
Test Item : Peak Power Output Data
Test Mode : Mode 4: SISO B Transmit (802.11g 6Mbps)_5M_Panel
Test Date : 2022/06/06

Channel No.	Frequency (MHz)	Data Rate (Mbps)	Power (dBm)	Limit (dBm)	Result
1	2412	6	25.59	28	Pass
6	2437	6	25.03	28	Pass
11	2462	6	25.79	28	Pass

Note: Peak Power Output Value = Reading value on power meter + cable loss

Product : Wireless AP / Bridge / Client
Test Item : Peak Power Output Data
Test Mode : Mode 5: SISO B Transmit (802.11g 6Mbps)_10M_Panel
Test Date : 2022/06/06

Channel No.	Frequency (MHz)	Data Rate (Mbps)	Power (dBm)	Limit (dBm)	Result
1	2412	6	25.21	28	Pass
6	2437	6	24.59	28	Pass
11	2462	6	24.92	28	Pass

Note: Peak Power Output Value =Reading value on power meter + cable loss

Product : Wireless AP / Bridge / Client
Test Item : Peak Power Output Data
Test Mode : Mode 6: SISO B Transmit (802.11g 6Mbps)_20M_Panel
Test Date : 2022/06/06

Channel No.	Frequency (MHz)	Data Rate (Mbps)	Power (dBm)	Limit (dBm)	Result
1	2412	6	25.83	28	Pass
6	2437	6	25.69	28	Pass
11	2462	6	25.62	28	Pass

Note: Peak Power Output Value = Reading value on power meter + cable loss

4. Radiated Emission

4.1. Test Setup

Radiated Emission Under 30MHz

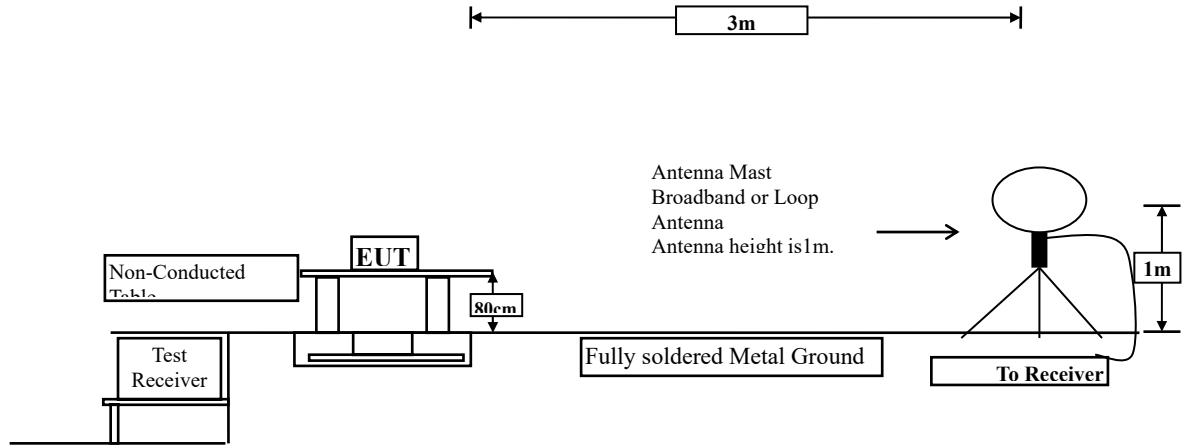

Radiated Emission Below 1GHz

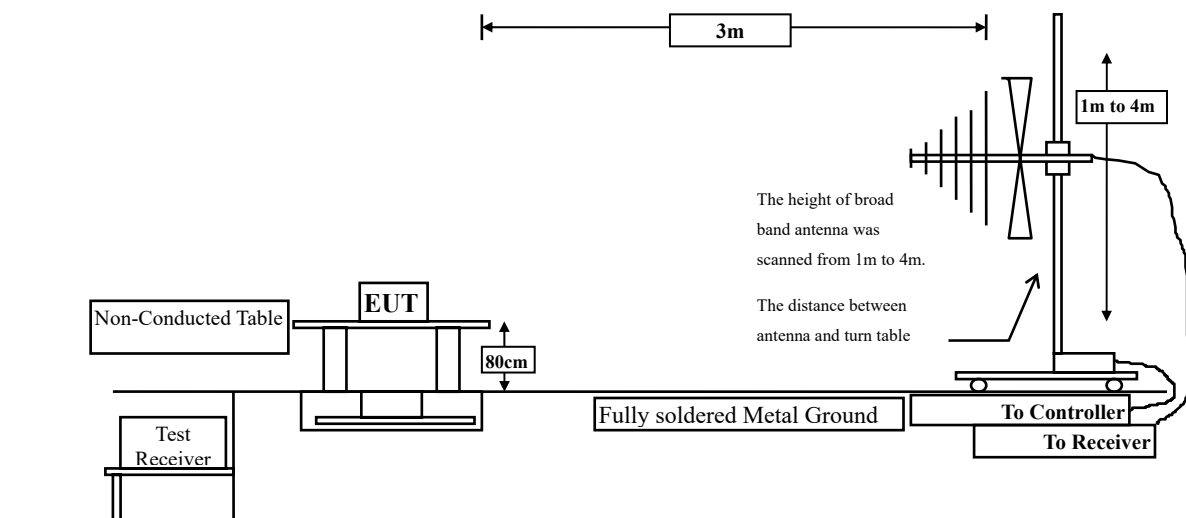

Radiated Emission Above 1GHz

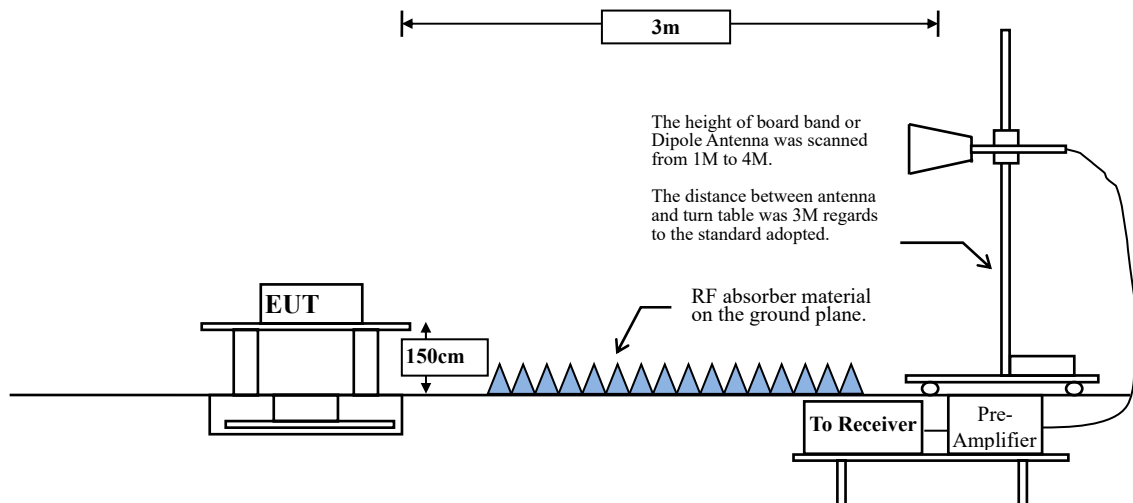

4.2. Limits

➤ General Radiated Emission Limits

Emissions radiated outside of the specified frequency bands, except for harmonics, shall be attenuated by at least 20dB below the level of the fundamental or to the general radiated emission limits in paragraph 15.209, whichever is the lesser attenuation.

FCC Part 15 Subpart C Paragraph 15.209 Limits		
Frequency MHz	Field strength (microvolts/meter)	Measurement distance (meter)
0.009-0.490	2400/F(kHz)	300
0.490-1.705	24000/F(kHz)	30
1.705-30	30	30
30-88	100	3
88-216	150	3
216-960	200	3
Above 960	500	3

- Remarks:
1. RF Voltage (dBuV) = 20 log RF Voltage (uV)
 2. In the Above Table, the tighter limit applies at the band edges.
 3. Distance refers to the distance in meters between the measuring instrument antenna and the closed point of any part of the device or system.

4.3. Test Procedure

The EUT was setup according to ANSI C63.10: 2013 and tested according to C63.10:2013 Section 11.12.1 for compliance to FCC 47CFR 15.247 requirements.

Measuring the frequency range below 1GHz, the EUT is placed on a turn table which is 0.8 meter above ground, when measuring the frequency range above 1GHz, the EUT is placed on a turn table which is 1.5 meter above ground.

The turn table is rotated 360 degrees to determine the position of the maximum emission level.

The EUT was positioned such that the distance from antenna to the EUT was 3 meters.

The antenna is scanned between 1 meter and 4 meters to find out the maximum emission level. This is repeated for both horizontal and vertical polarization of the antenna. In order to find the maximum emission, all of the interface cables were manipulated according to ANSI C63.10: 2013 on radiated measurement.

The resolution bandwidth below 30MHz setting on the field strength meter is 9kHz and 30MHz~1GHz is 120kHz and above 1GHz is 1MHz.

Radiated emission measurements below 30MHz are made using Loop Antenna and 30MHz~1GHz are made using broadband Bilog antenna and above 1GHz are made using Horn Antennas.

The measurement is divided into the Preliminary Measurement and the Final Measurement.

The suspected frequencies are searched for in Preliminary Measurement with the measurement antenna kept pointed at the source of the emission both in azimuth and elevation, with the polarization of the antenna oriented for maximum response. The antenna is pointed at an angle towards the source of the emission, and the EUT is rotated in both height and polarization to maximize the measured emission. The emission is kept within the illumination area of the 3 dB bandwidth of the antenna.

The measurement frequency range from 9kHz - 10th Harmonic of fundamental was investigated.

RBW and VBW Parameter setting:

According to C63.10 Section 11.12.2.4 Peak measurement procedure.

RBW = as specified in Table 1.

$VBW \geq 3 \times RBW$.

Table 1 —RBW as a function of frequency

Frequency	RBW
9-150 kHz	200-300 Hz
0.15-30 MHz	9-10 kHz
30-1000 MHz	100-120 kHz
> 1000 MHz	1 MHz

According to C63.10 Section 11.12.2.5 Average measurement procedure.

RBW = 1MHz.

VBW = 10Hz, when duty cycle $\geq 98\%$

$VBW \geq 1/T$, when duty cycle $< 98\%$

(T refers to the minimum transmission duration over which the transmitter is on and is transmitting at its maximum power control level for the tested mode of operation.)

2.4GHz band	Duty Cycle (%)	T (ms)	1/T (Hz)	VBW (Hz)
802.11 g 5M	95.07	1.2350	810	1000
802.11 g 10M	95.08	0.6190	1616	2000
802.11 g 20M	82.57	0.3080	3247	5000

4.4. Test Result of Radiated Emission

SISO A_Diople

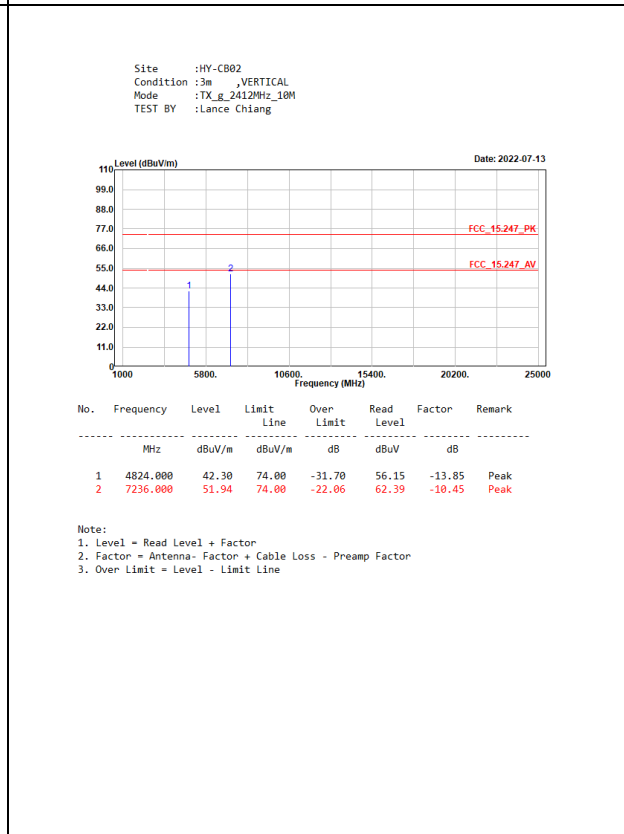
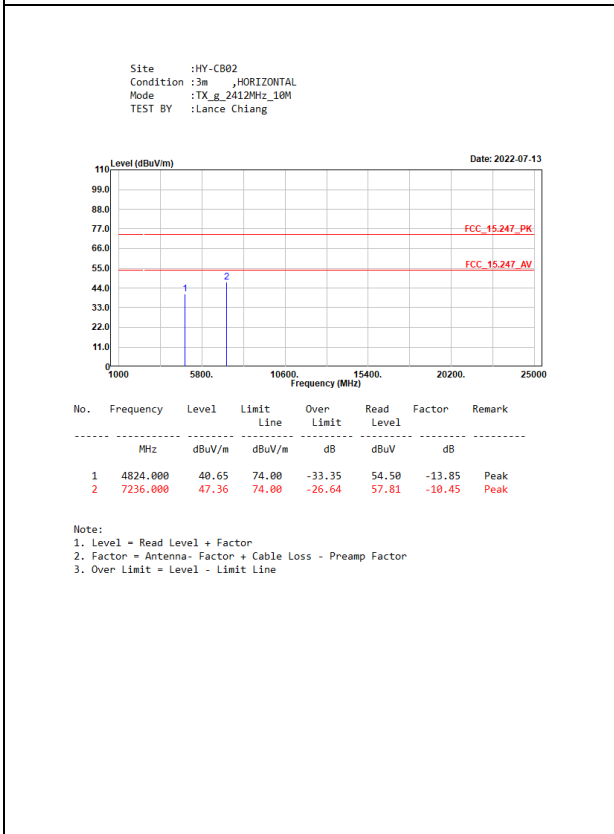
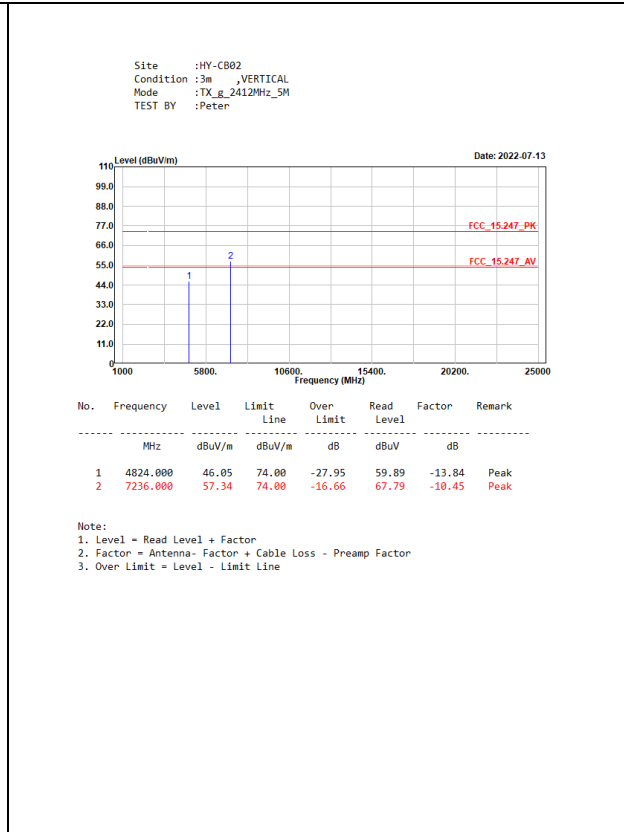
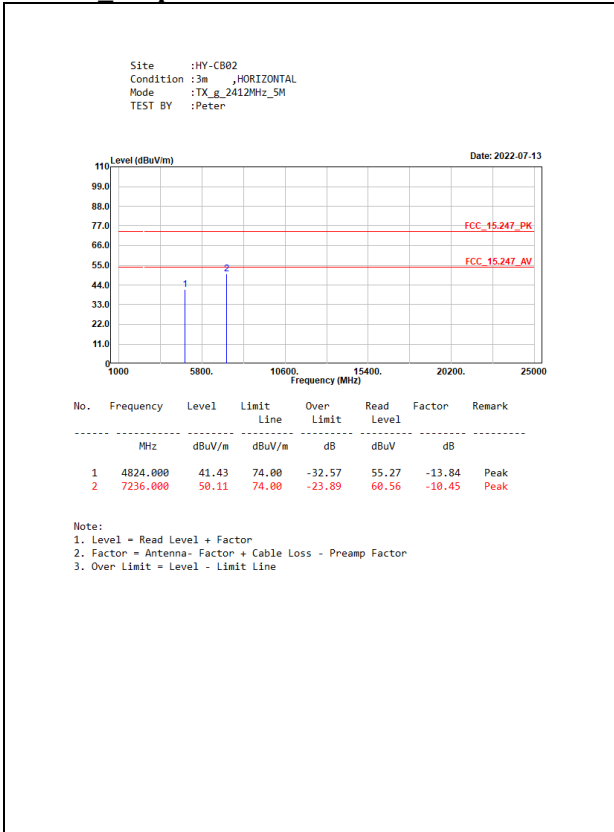

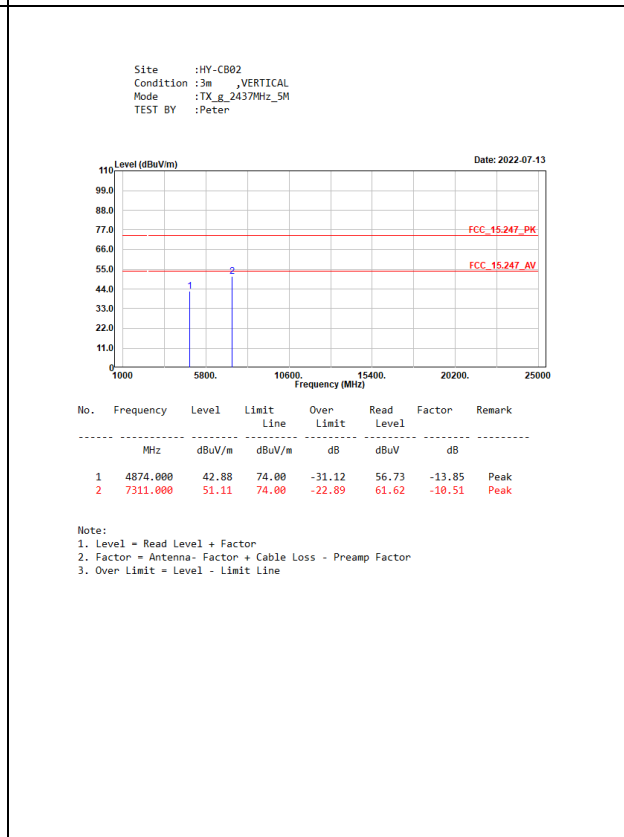
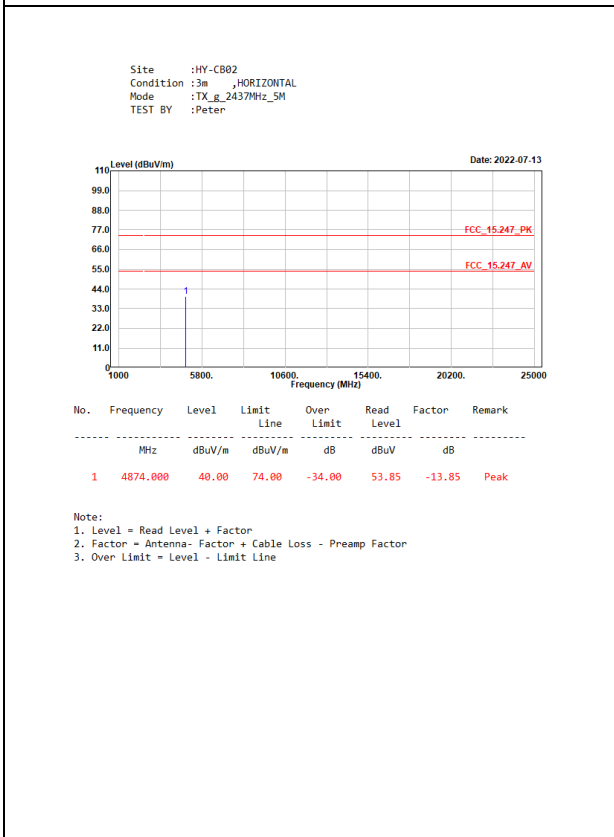
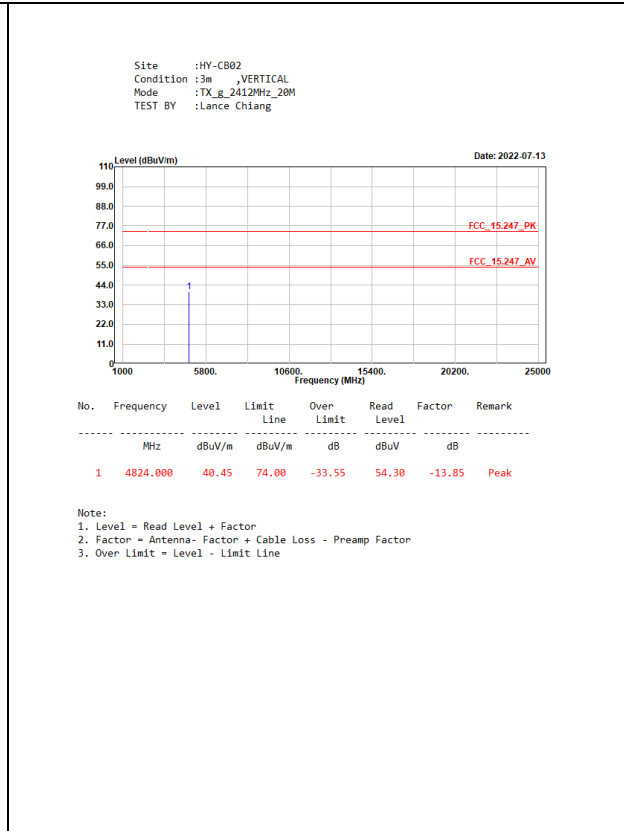
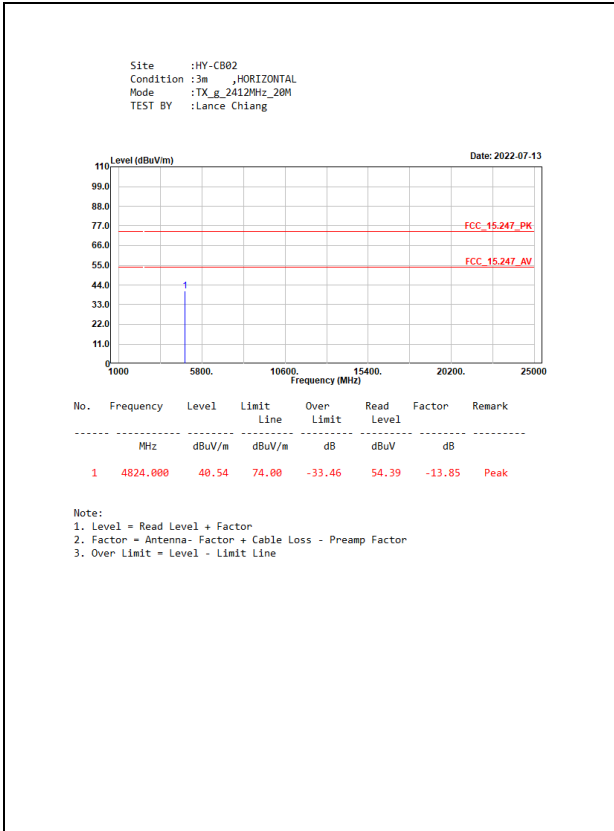

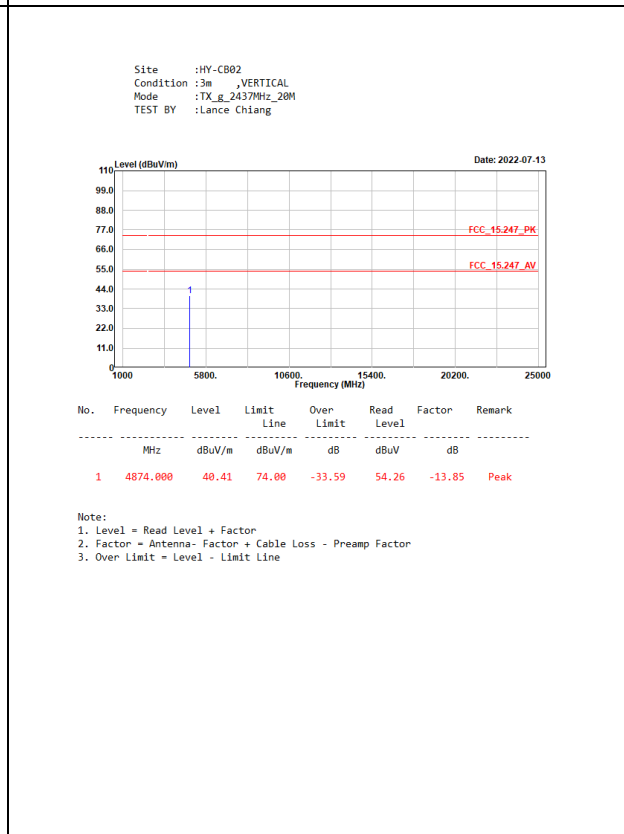
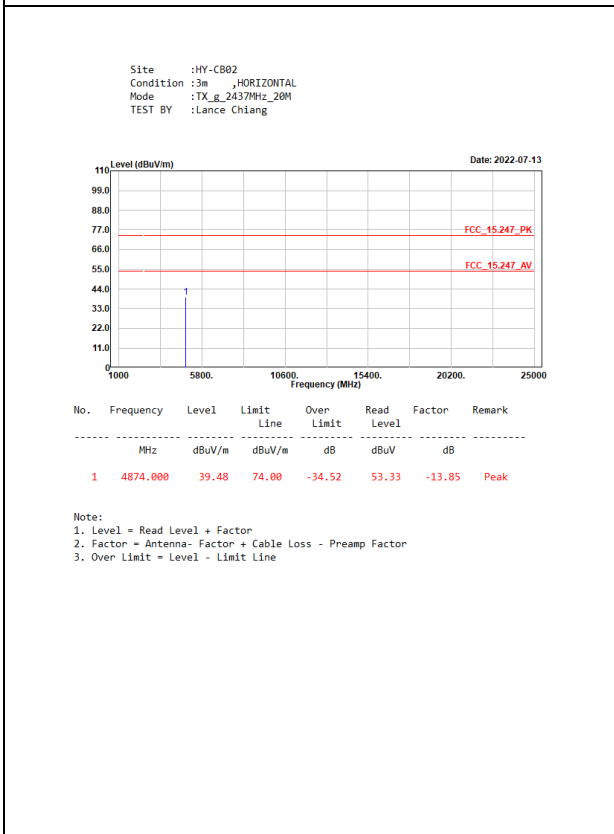
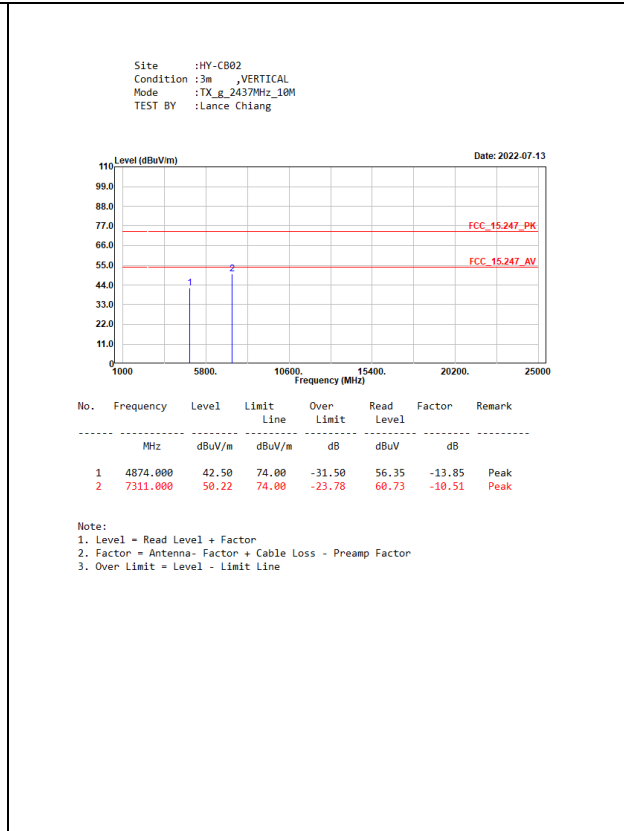
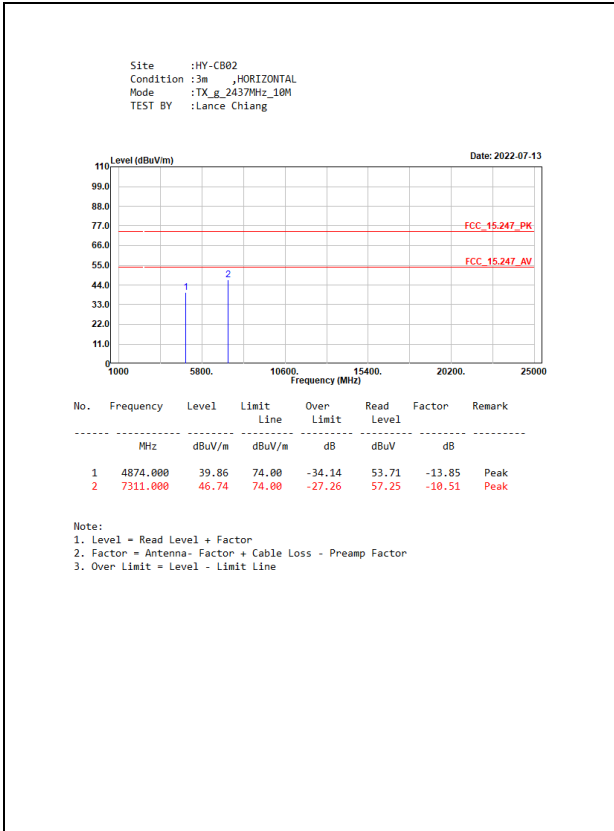

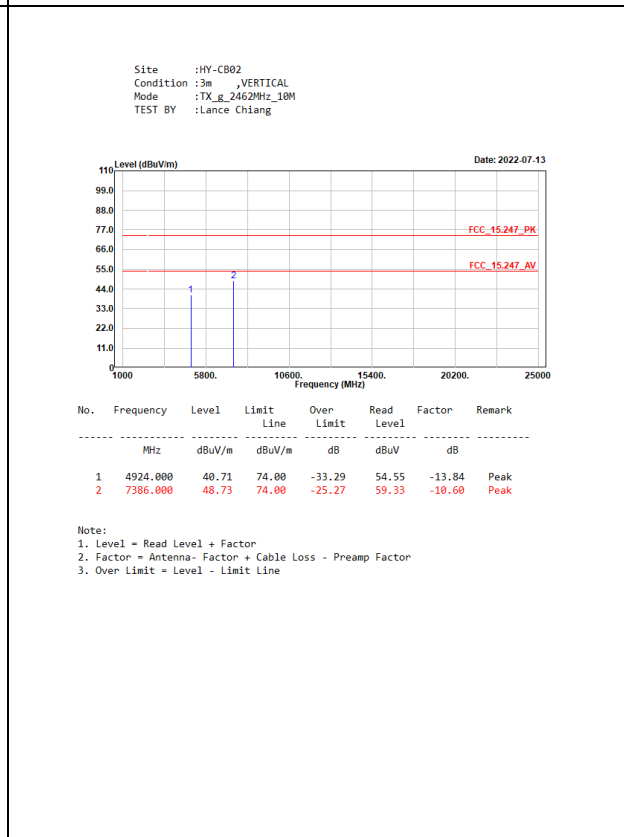
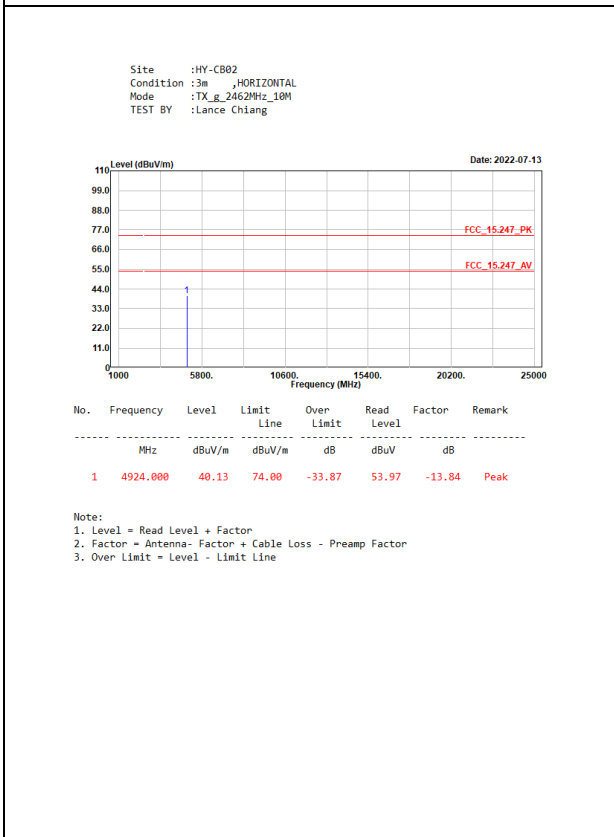
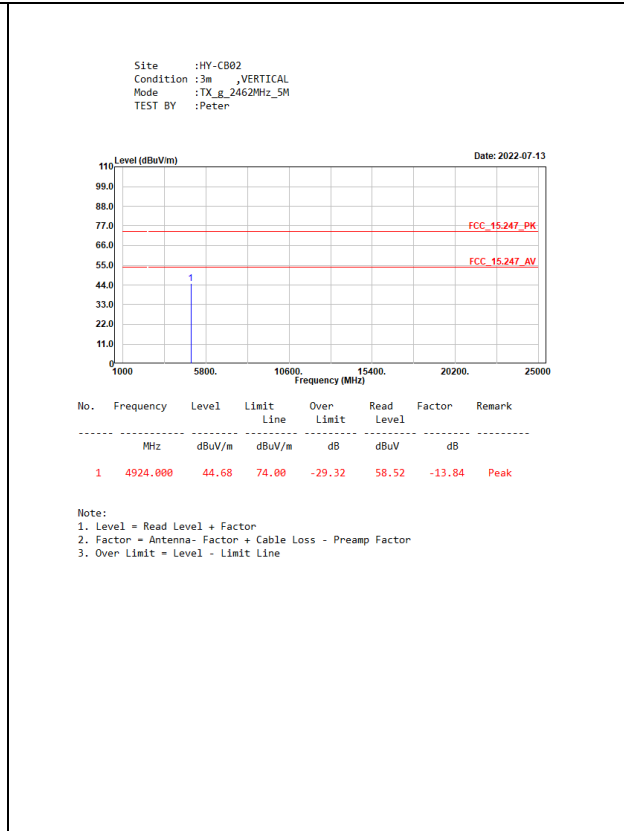
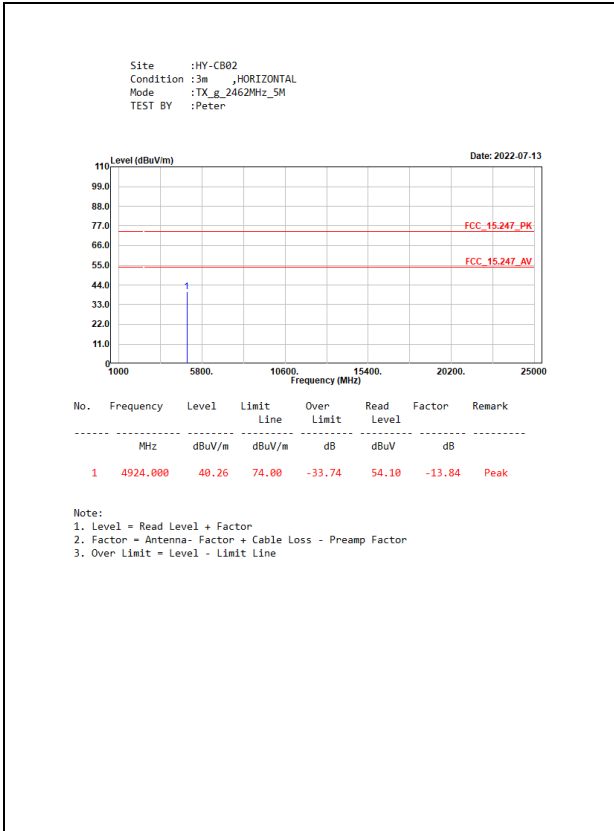

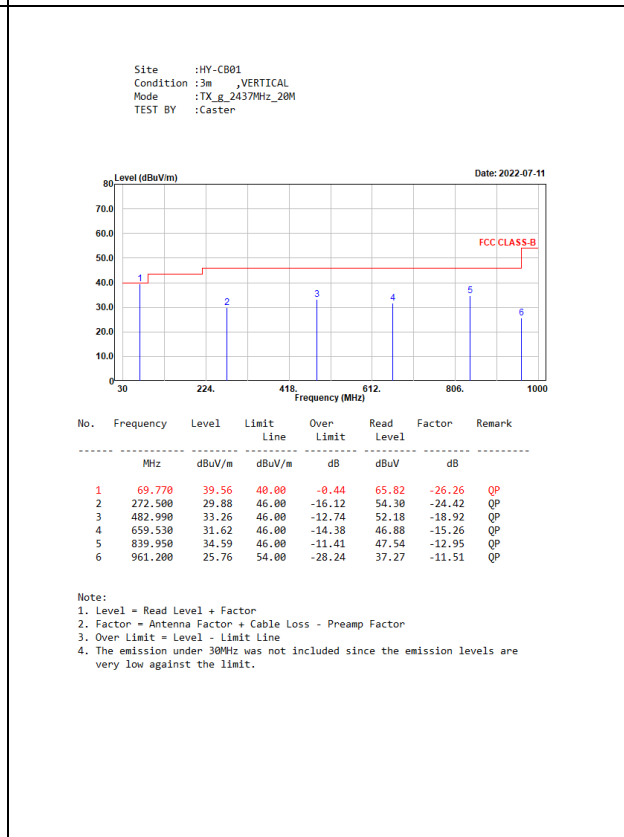
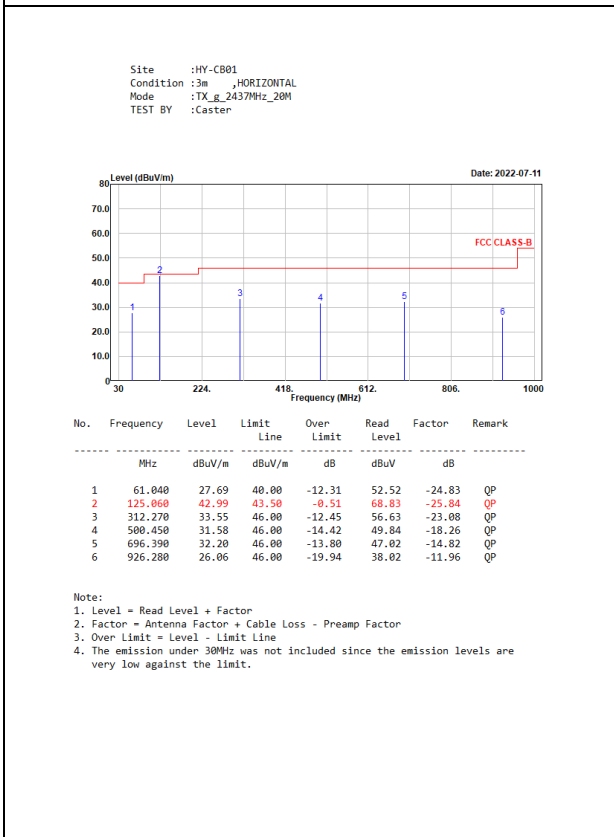
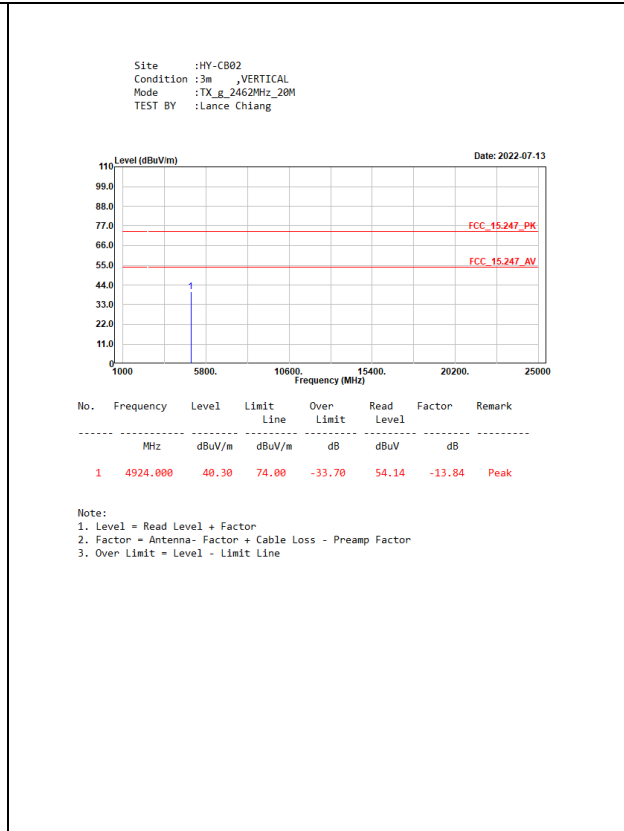
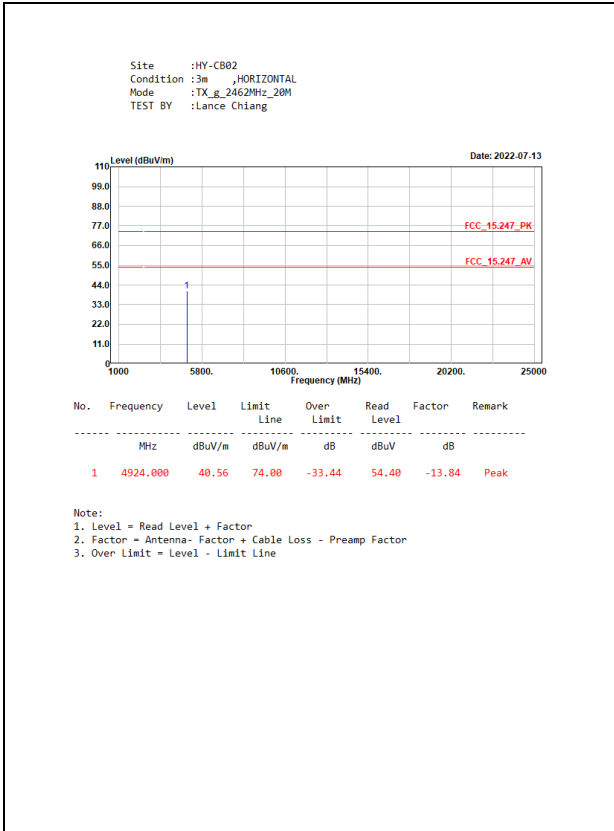

SISO A Panel

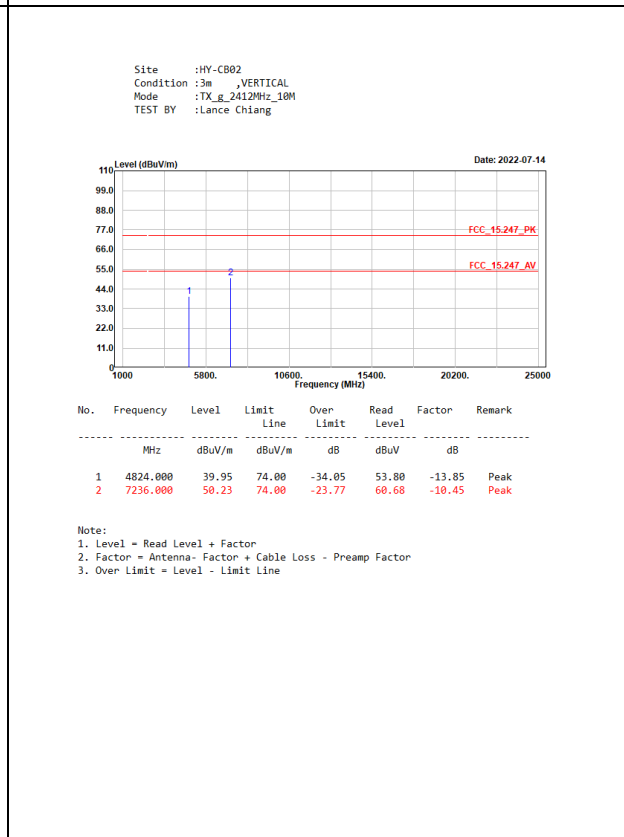
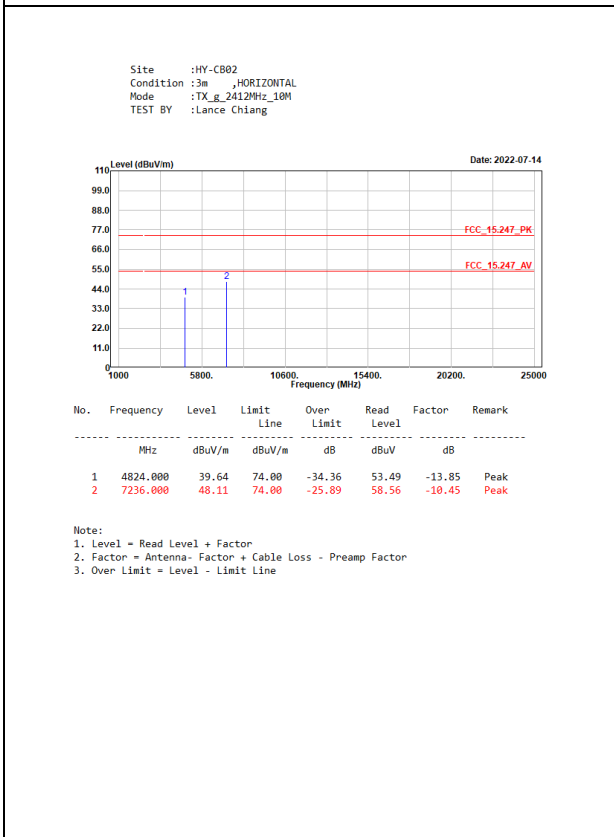
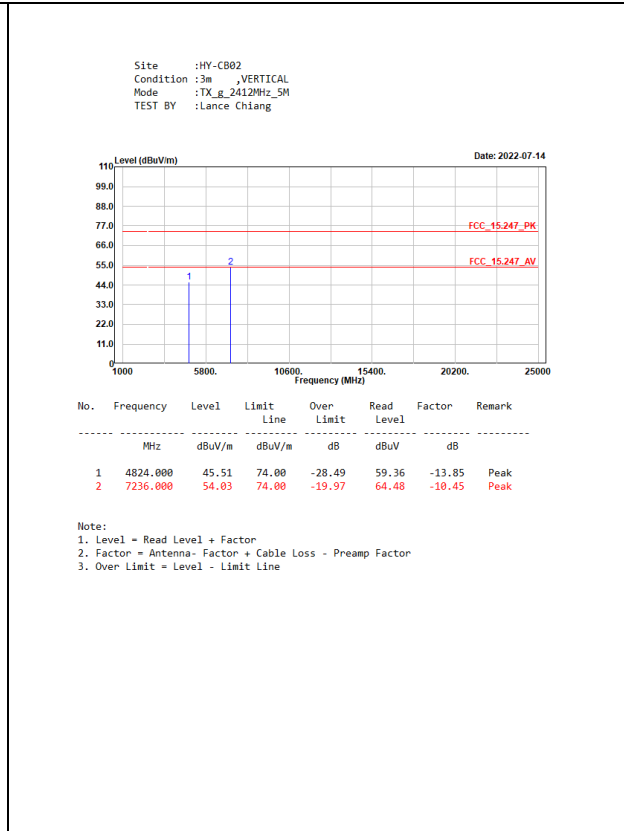
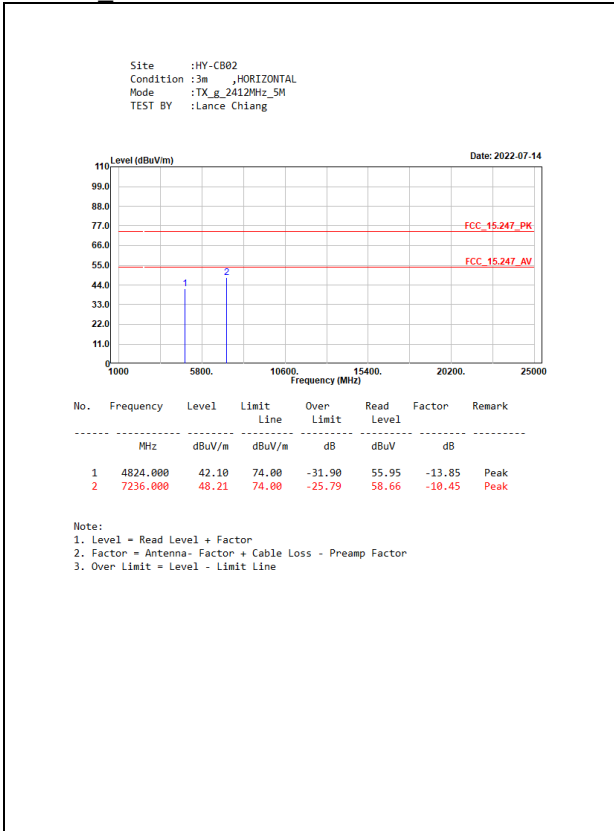

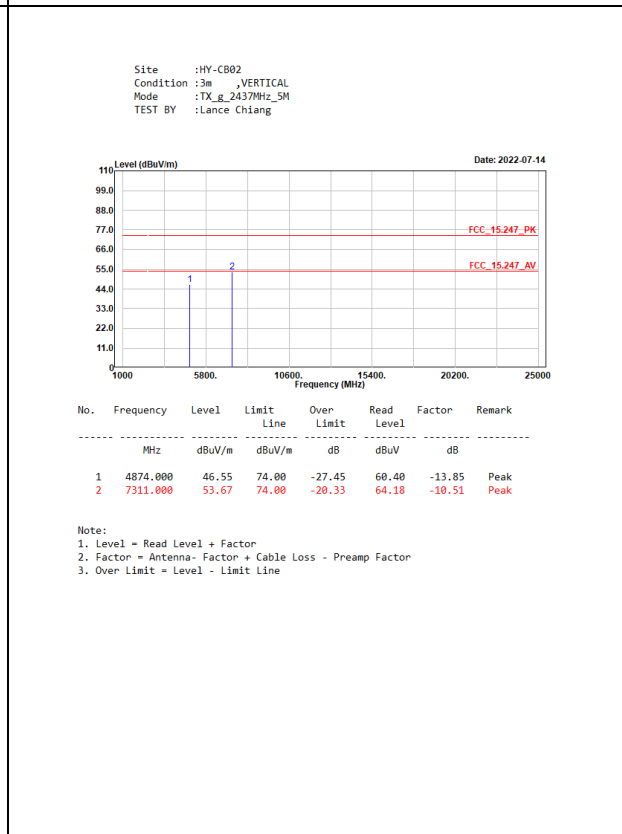
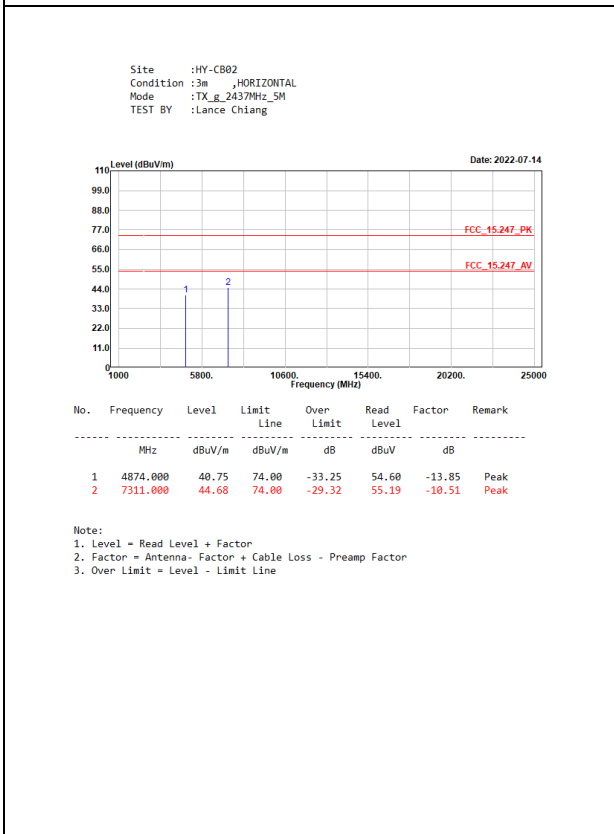
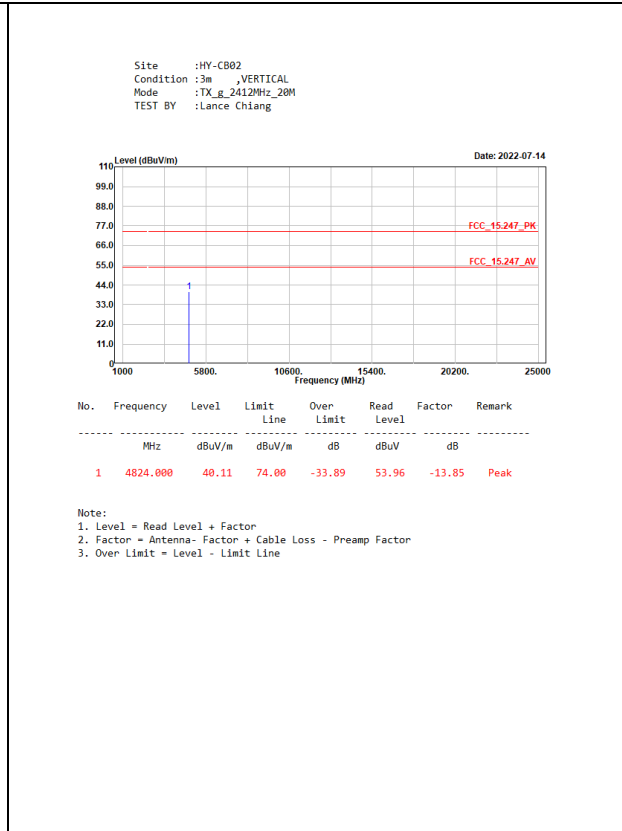
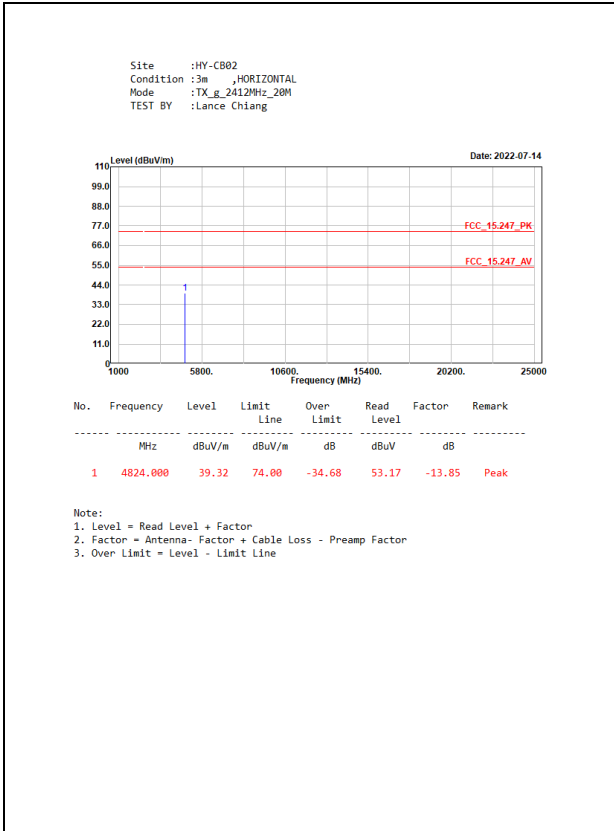

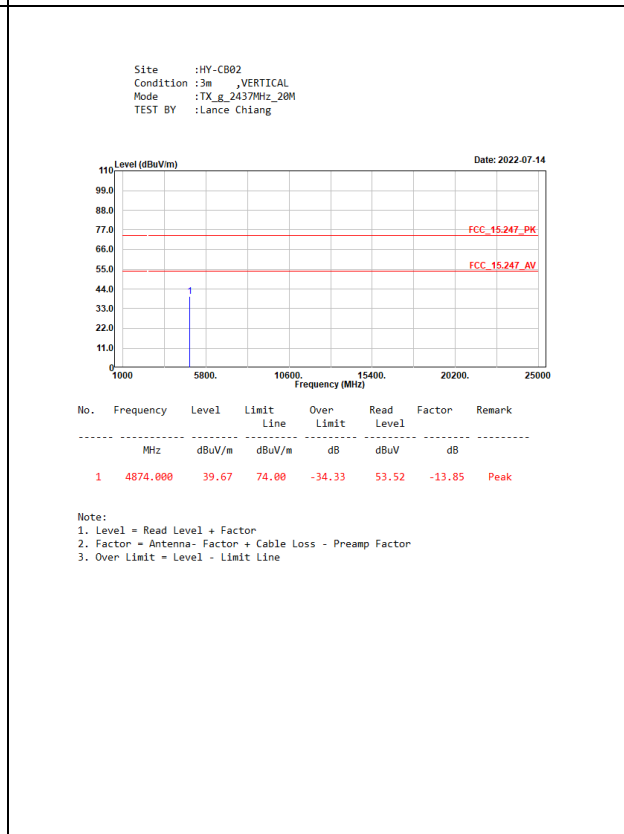
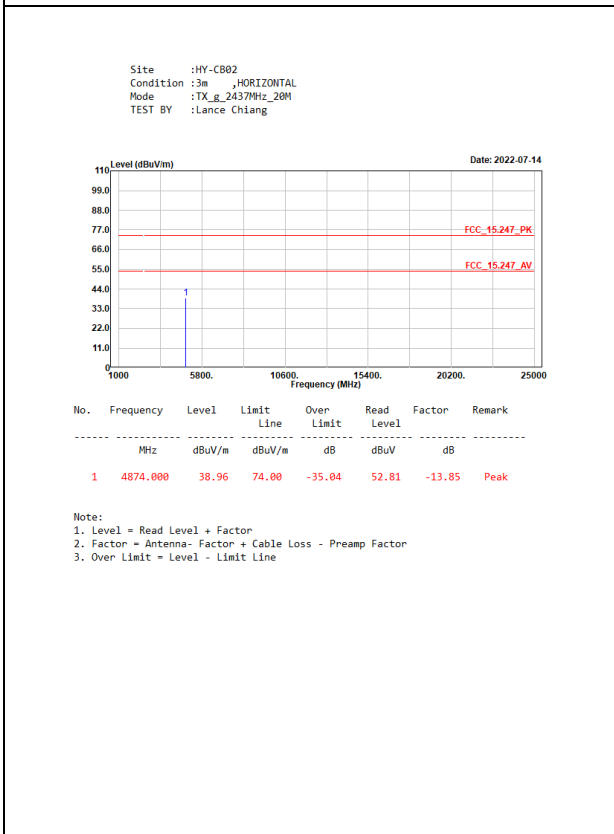
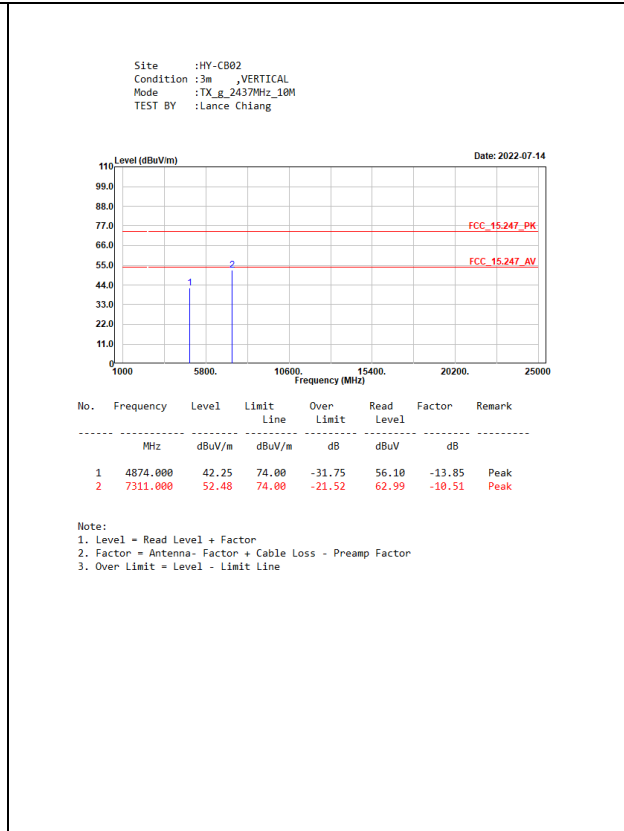
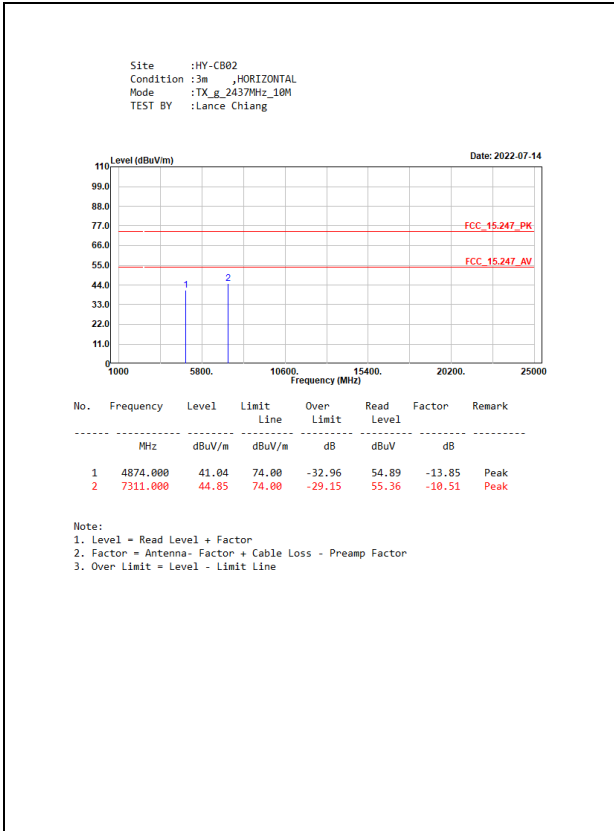

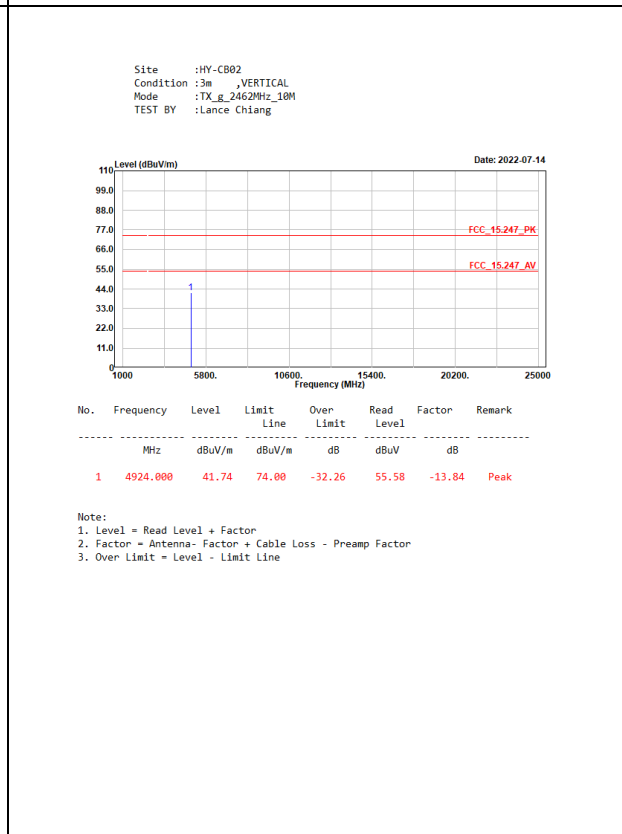
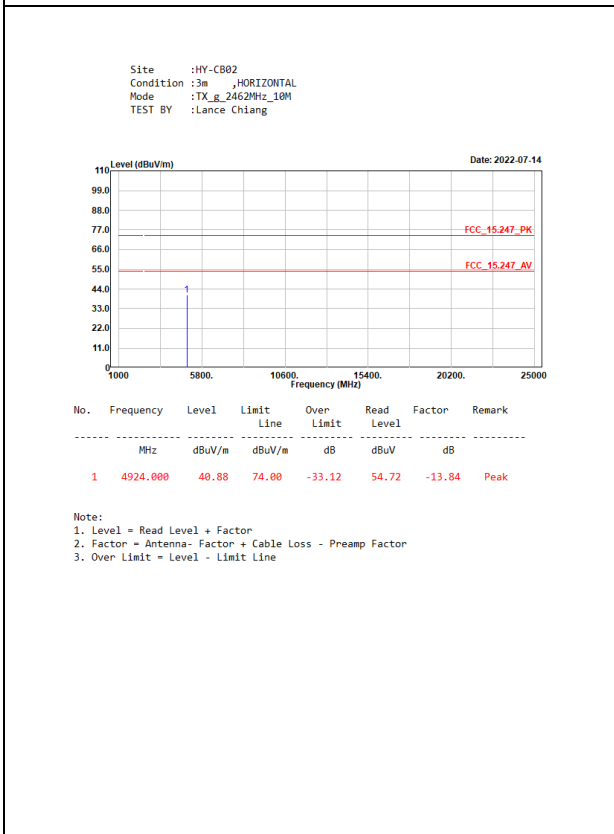
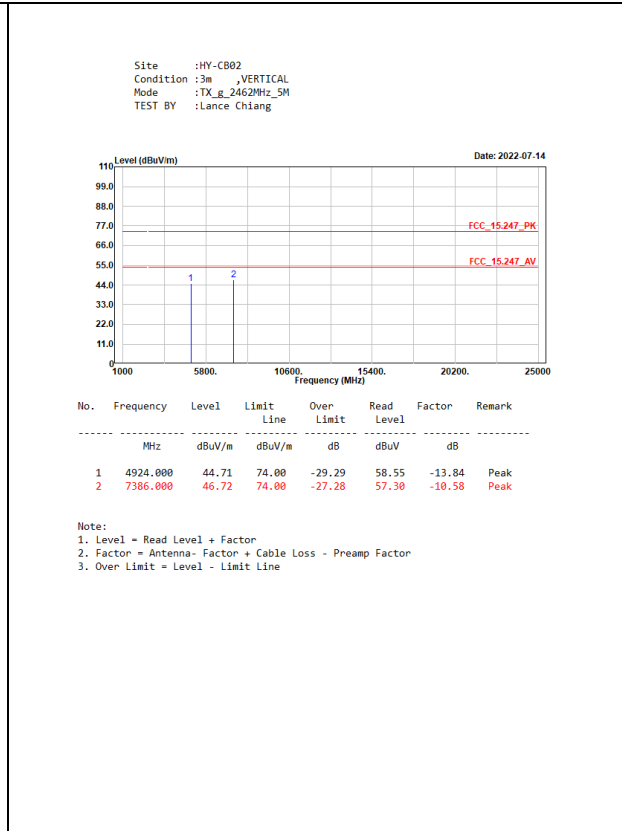
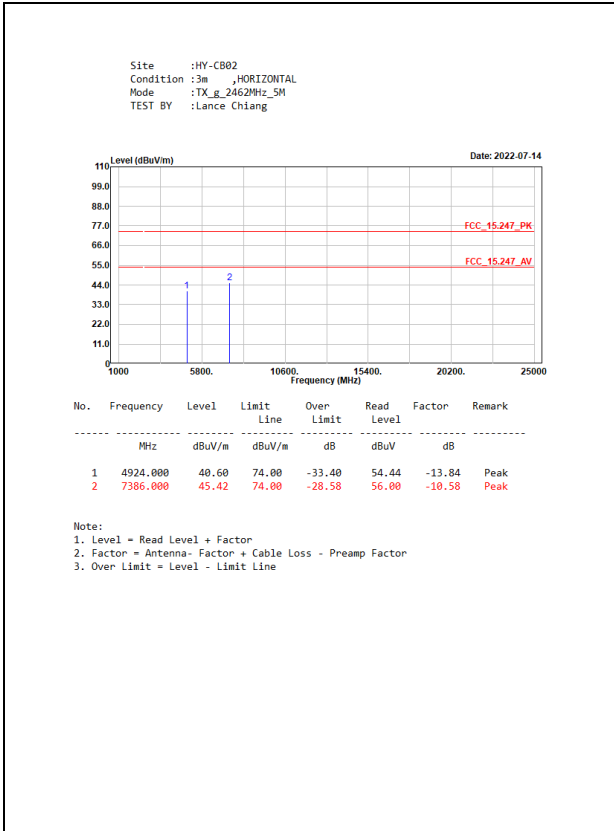

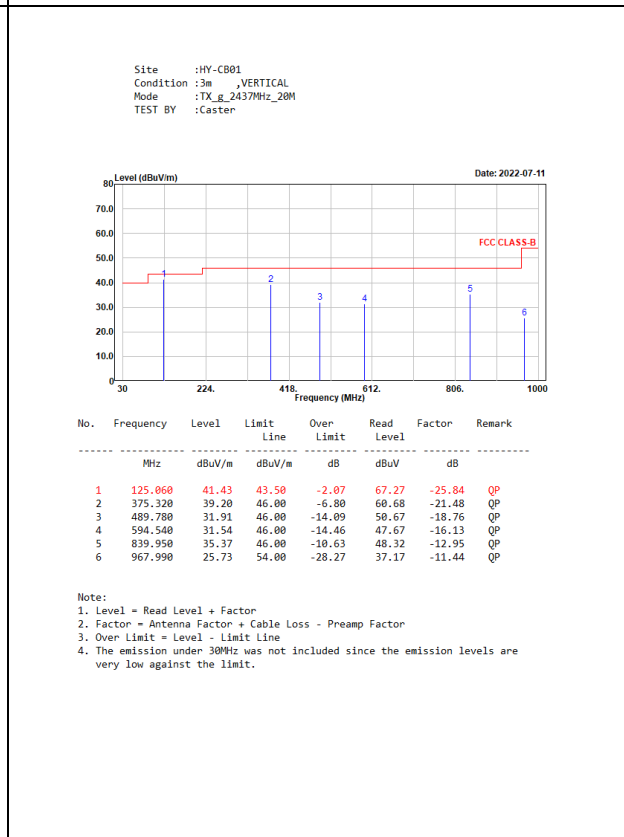
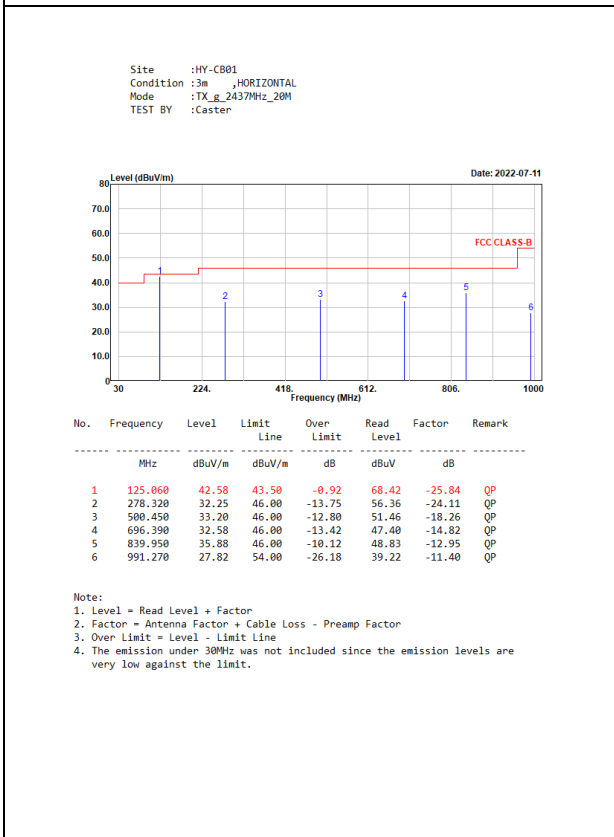
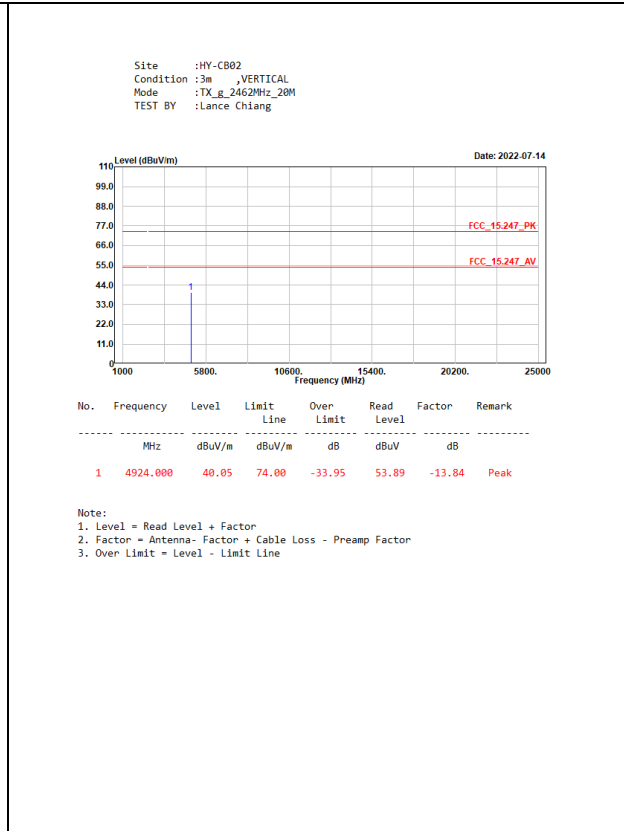
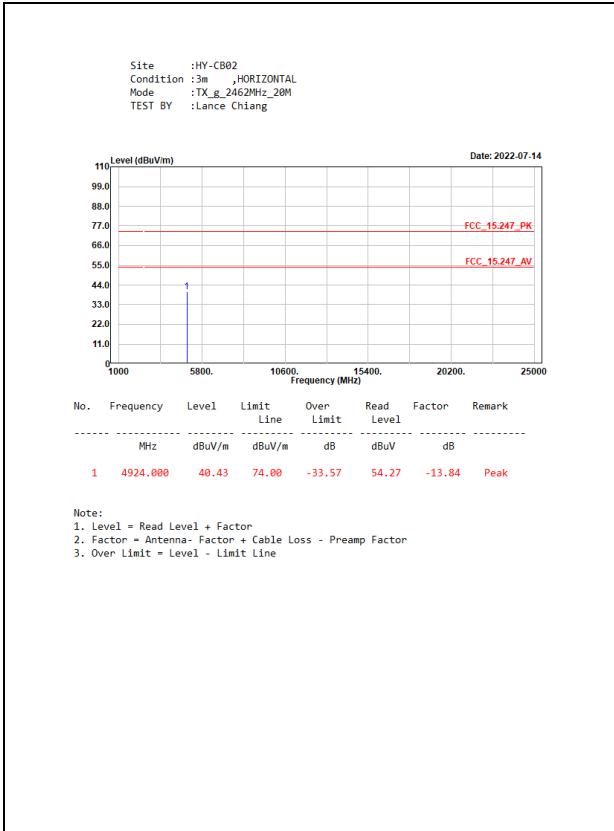

5. RF antenna conducted test

5.1. Test Setup

RF antenna Conducted Measurement:

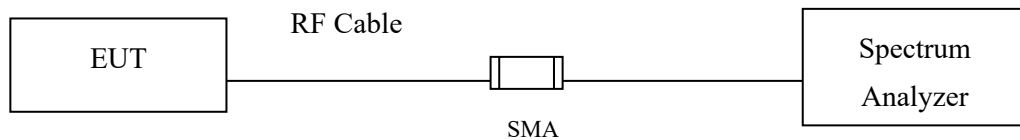

5.2. Limits

In any 100 kHz bandwidth outside the frequency band in which the spread spectrum intentional radiator is operating, the radio frequency power that is produced by the intentional radiator shall be at least 20 dB below that in the 100 kHz bandwidth within the band that contains the highest level of the desired power, based on either an RF conducted or a radiated measurement. Attenuation below the general limits specified in Section 15.209(a) is not required. In addition, radiated emissions which fall in the restricted bands, as defined in Section 15.205(a), must also comply with the radiated emission limits specified in Section 15.209(a) (see Section 15.205(c)).

5.3. Test Procedure

The EUT was tested according to C63.10:2013 Section 11.11 for compliance to FCC 47CFR 15.247 requirements.

Set RBW = 100 kHz, Set VBW > RBW, scan up through 10th harmonic.

5.4. Test Result of RF antenna conducted test

Product : Wireless AP / Bridge / Client
Test Item : RF antenna conducted test
Test Mode : Mode 1: SISO A Transmit (802.11g 6Mbps)_5M_Dipole
Test Date : 2022/06/07

Channel 11 (2462MHz)

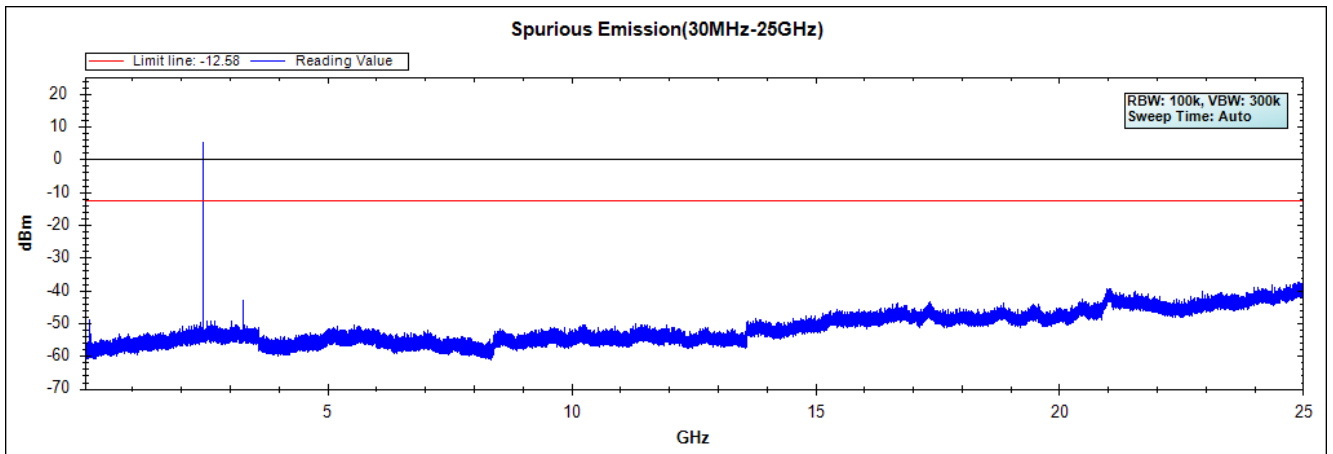

Product : Wireless AP / Bridge / Client
Test Item : RF Antenna Conducted Spurious
Test Mode : Mode 2: SISO A Transmit (802.11g 6Mbps)_10M_Dipole
Test Date : 2022/06/07

Channel 6 (2437MHz)

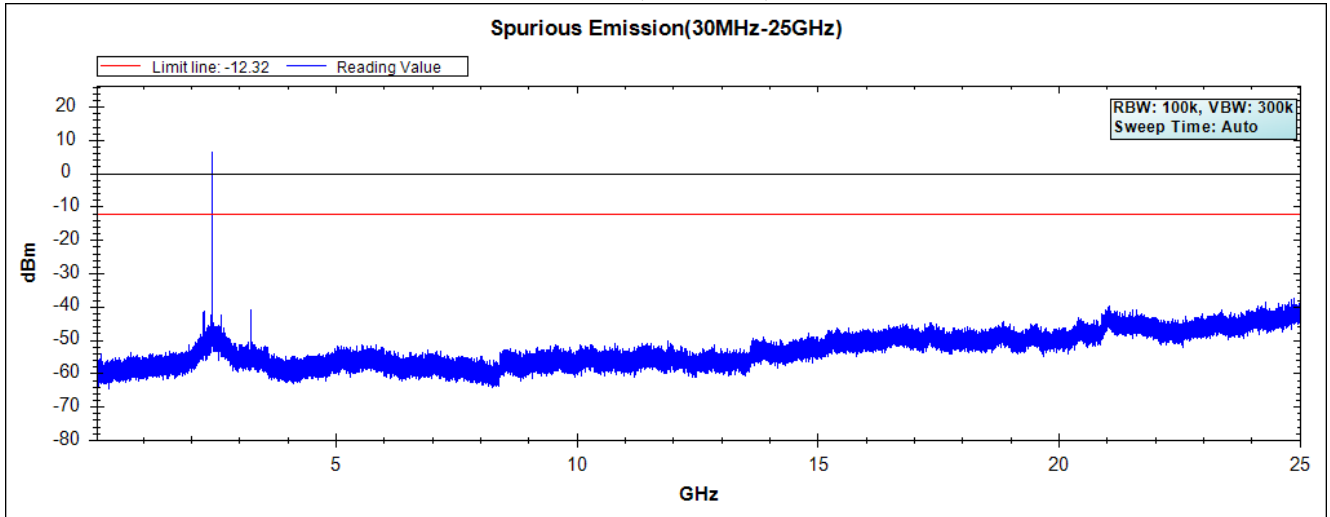

Product : Wireless AP / Bridge / Client
Test Item : RF Antenna Conducted Spurious
Test Mode : Mode 3: SISO A Transmit (802.11g 6Mbps)_20M_Dipole
Test Date : 2022/06/07

Channel 01 (2412MHz)

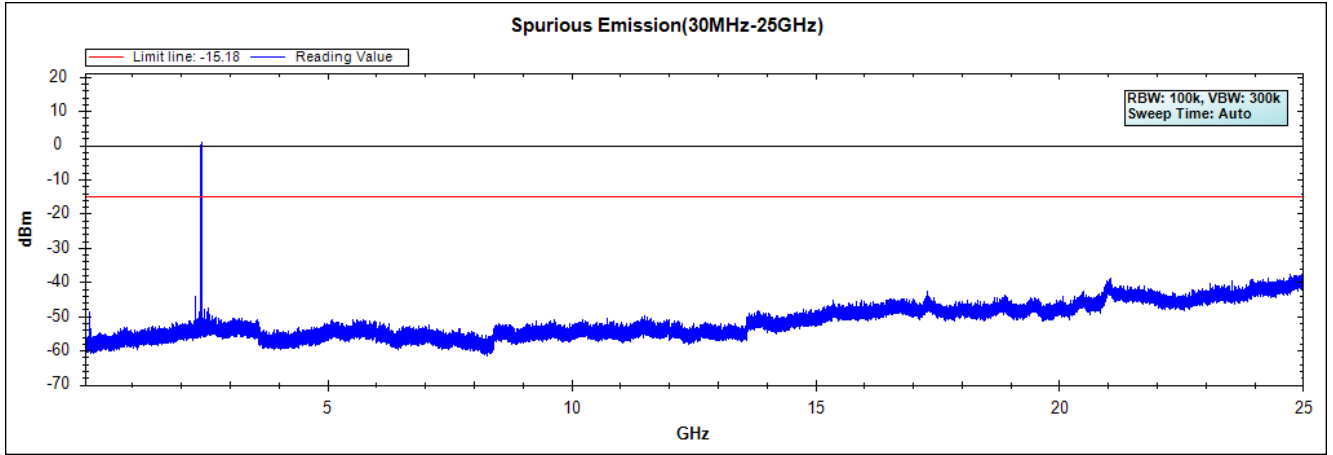

Product : Wireless AP / Bridge / Client
Test Item : RF antenna conducted test
Test Mode : Mode 1: SISO A Transmit (802.11g 6Mbps)_5M_Panel
Test Date : 2022/06/07

Channel 11 (2462MHz)

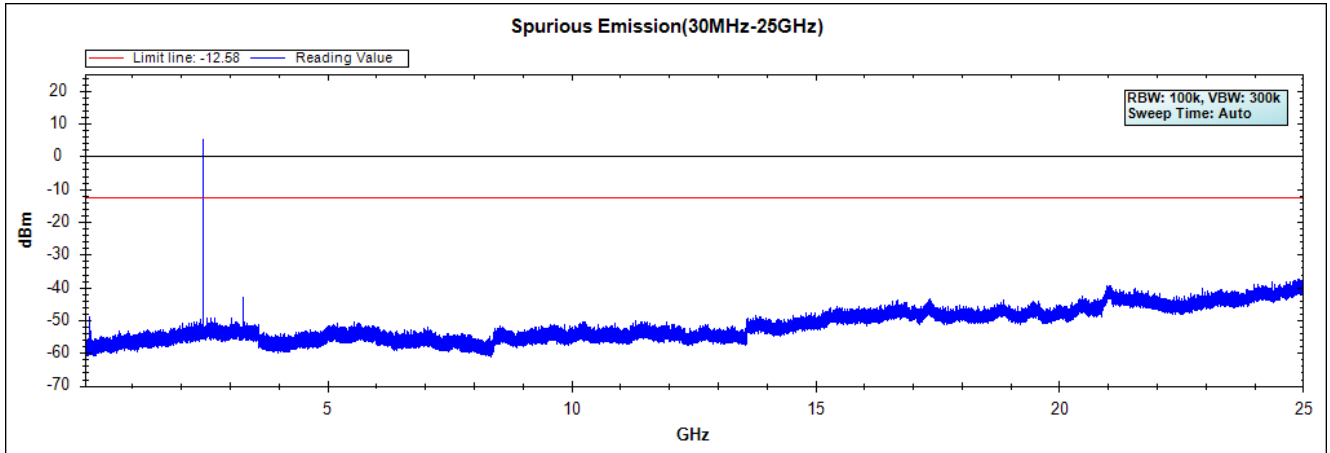

Product : Wireless AP / Bridge / Client
Test Item : RF Antenna Conducted Spurious
Test Mode : Mode 2: SISO A Transmit (802.11g 6Mbps)_10M_Panel
Test Date : 2022/06/07

hannel 6 (2437MHz)

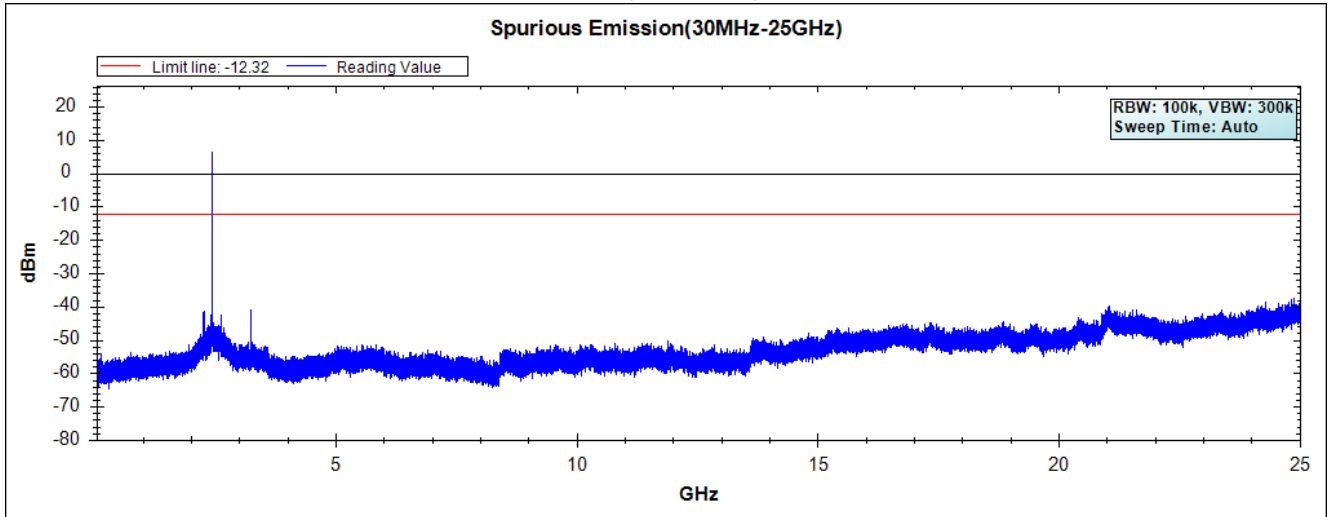

Product : Wireless AP / Bridge / Client
Test Item : RF Antenna Conducted Spurious
Test Mode : Mode 3: SISO A Transmit (802.11g 6Mbps)_20M_Panel
Test Date : 2022/06/07

Channel 01 (2412MHz)

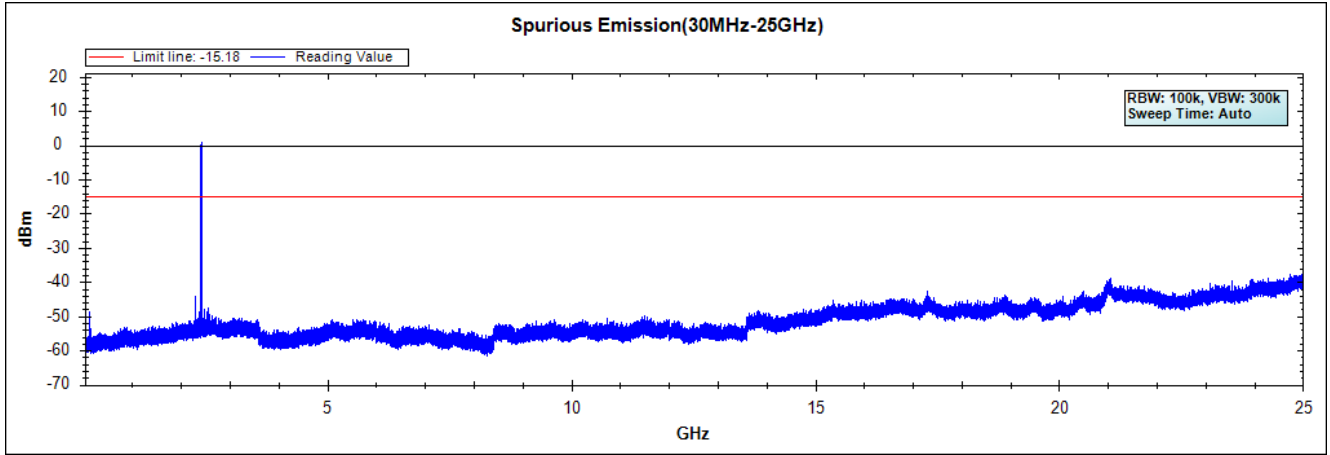

6. Band Edge

6.1. Test Setup

RF Conducted Measurement

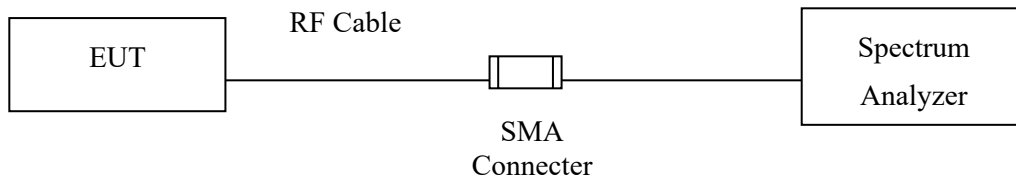

RF Radiated Measurement:

Above 1GHz

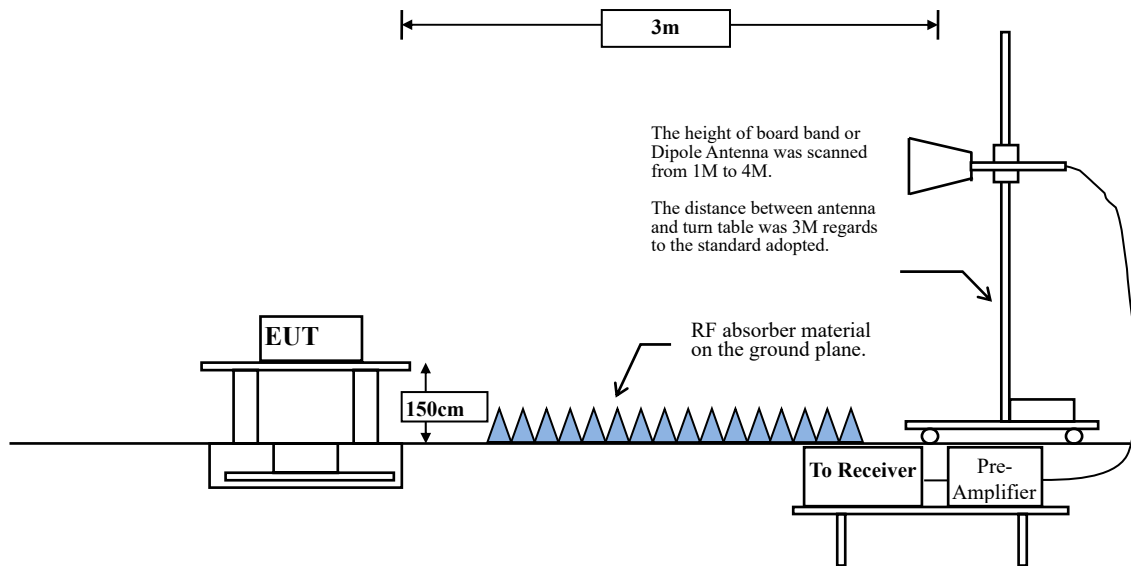

6.2. Limits

According to FCC Section 15.247(d). In any 100 kHz bandwidth outside the frequency band in which the spread spectrum or digitally modulated intentional radiator is operating, the radio frequency power that is produced by the intentional radiator shall be at least 20 dB below that in the 100 kHz bandwidth within the band that contains the highest level of the desired power, based on either an RF conducted or measurement, provided the transmitter demonstrates compliance with the peak conducted power limits. If the transmitter complies with the conducted power limits based on the use of RMS averaging over a time interval, the attenuation required under this paragraph shall be 30 dB instead of 20 dB. Attenuation below the general limits specified in Section 15.209(a) is not required. In addition, radiated emissions which fall in the restricted bands, as defined in Section 15.205(a), must also comply with the radiated emission limits specified in Section 15.209(a) (see Section 15.205(c)).

6.3. Test Procedure

The EUT was setup according to ANSI C63.10, 2013 and tested according to C63.10:2013 Section 11.12.1 for compliance to FCC 47CFR 15.247 requirements.

The EUT is placed on a turn table which is 1.5 meter above ground. The turn table is rotated 360 degrees to determine the position of the maximum emission level. The EUT was positioned such that the distance from antenna to the EUT was 3 meters.

The antenna is scanned from 1 meter to 4 meters to find out the maximum emission level. This is repeated for both horizontal and vertical polarization of the antenna. In order to find the maximum emission, all of the interface cables were manipulated according to ANSI C63.10:2013 on radiated measurement.

RBW and VBW Parameter setting:

According to C63.10 Section 11.12.2.4 Peak measurement procedure.

RBW = as specified in Table 1.

$VBW \geq 3 \times RBW$.

Table 1 —RBW as a function of frequency

Frequency	RBW
9-150 kHz	200-300 Hz
0.15-30 MHz	9-10 kHz
30-1000 MHz	100-120 kHz
> 1000 MHz	1 MHz

According to C63.10 Section 11.12.2.5 Average measurement procedure.

RBW = 1MHz.

VBW = 10Hz, when duty cycle $\geq 98 \%$

$VBW \geq 1/T$, when duty cycle $< 98 \%$

(T refers to the minimum transmission duration over which the transmitter is on and is transmitting at its maximum power control level for the tested mode of operation.)

2.4GHz band	Duty Cycle (%)	T (ms)	1/T (Hz)	VBW (Hz)
802.11 g 5M	95.07	1.2350	810	1000
802.11 g 10M	95.08	0.6190	1616	2000
802.11 g 20M	82.57	0.3080	3247	5000

6.4. Test Result of Band Edge

SISO A_Diople

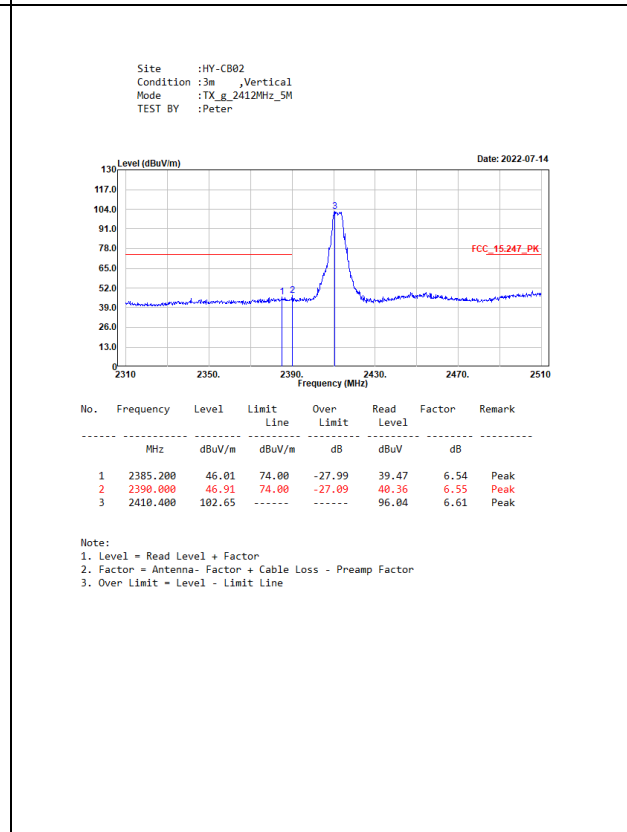
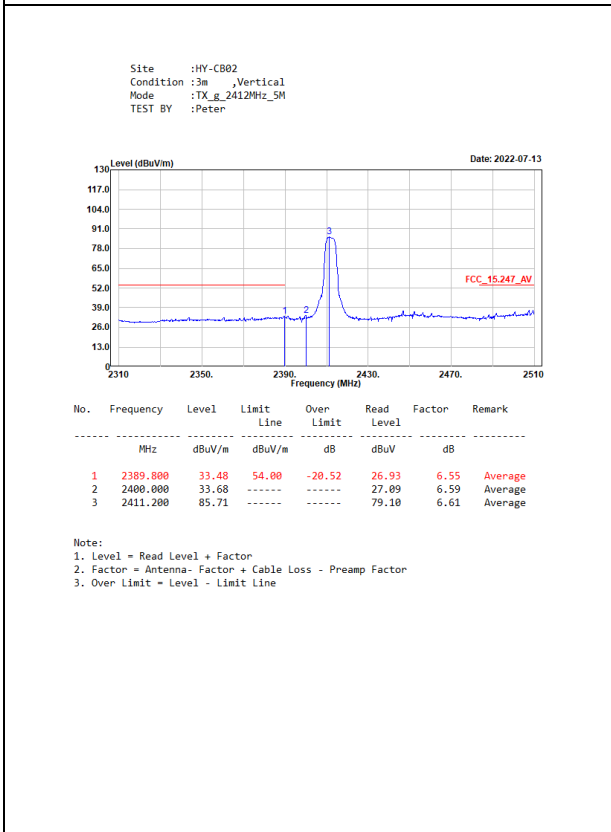
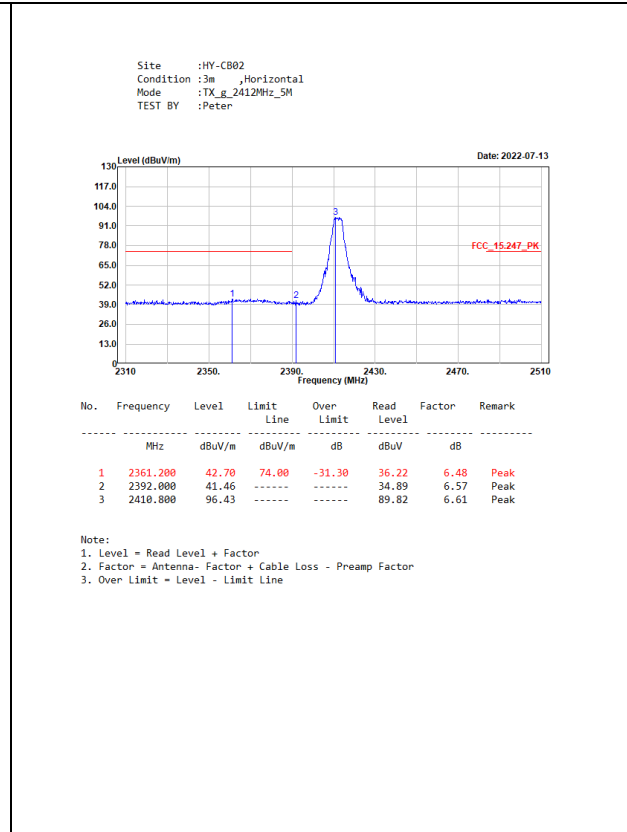
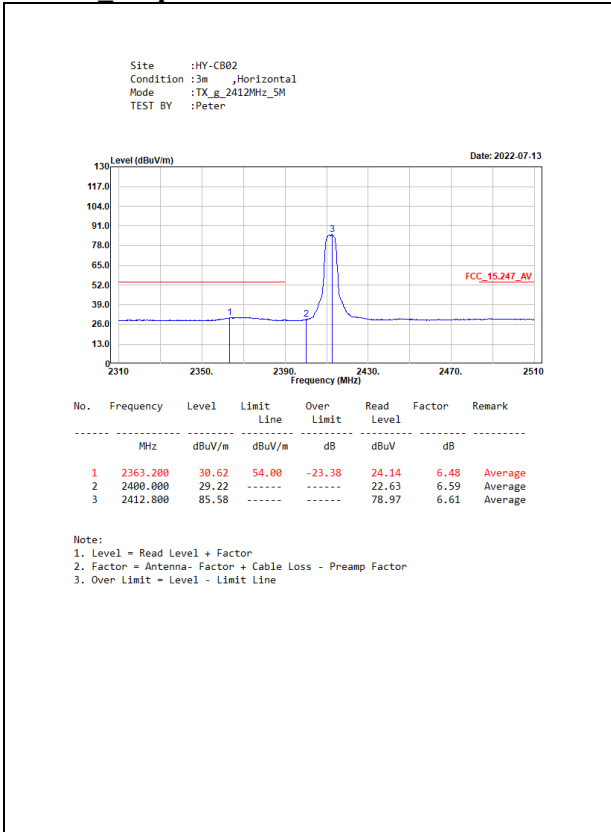

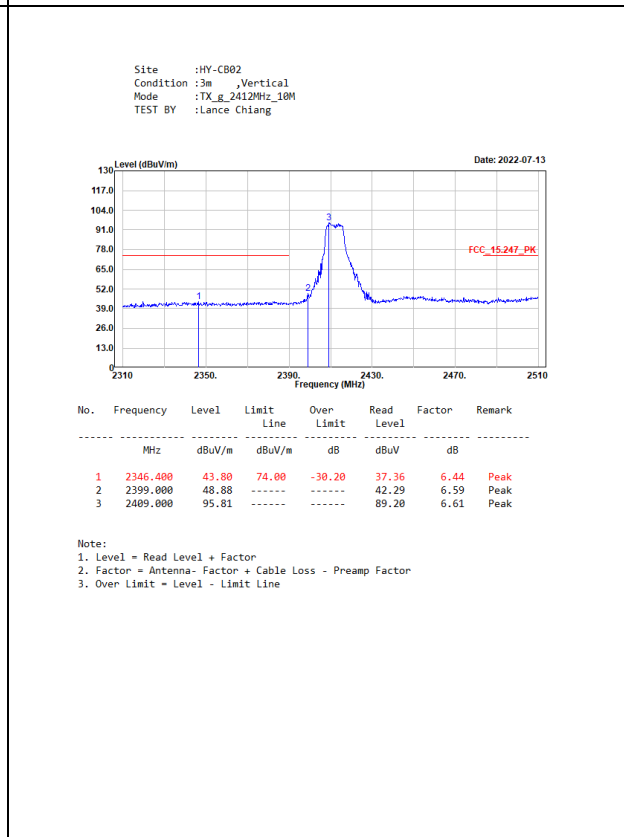
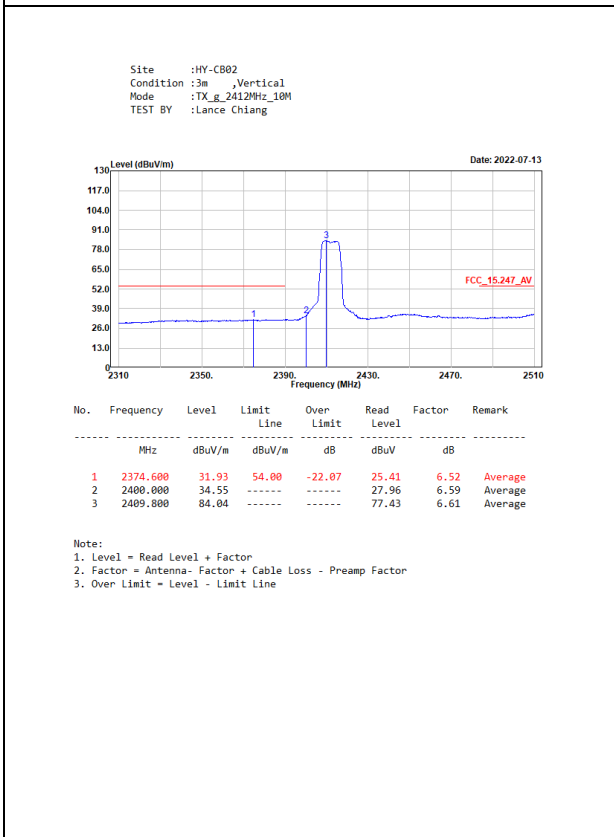
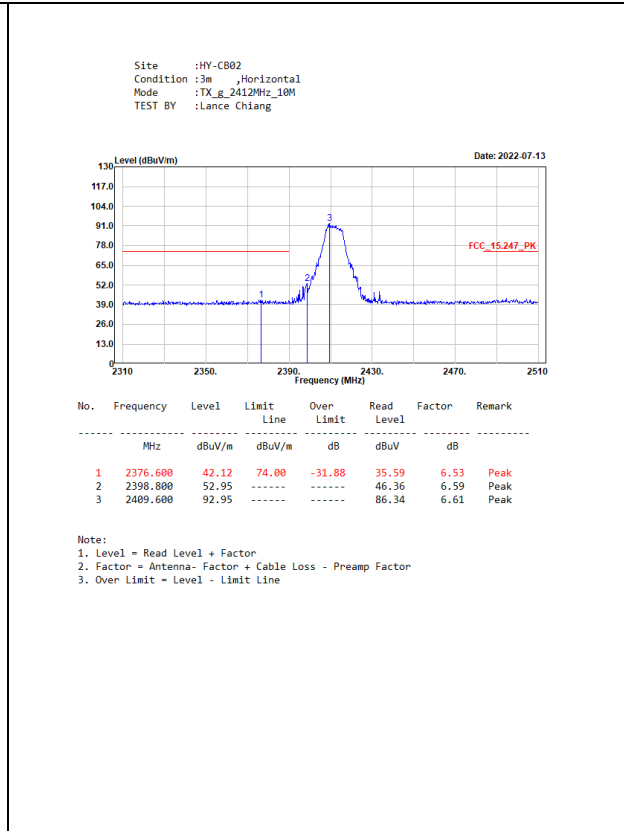
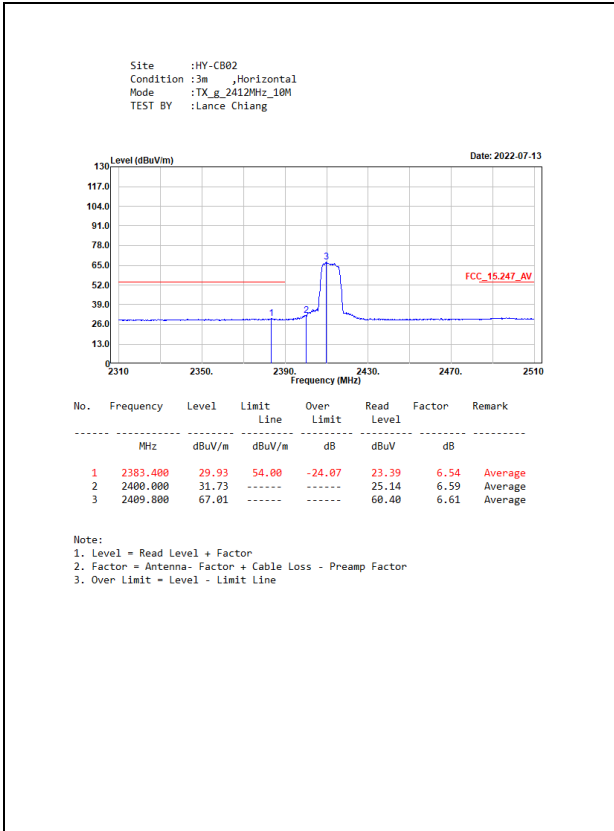

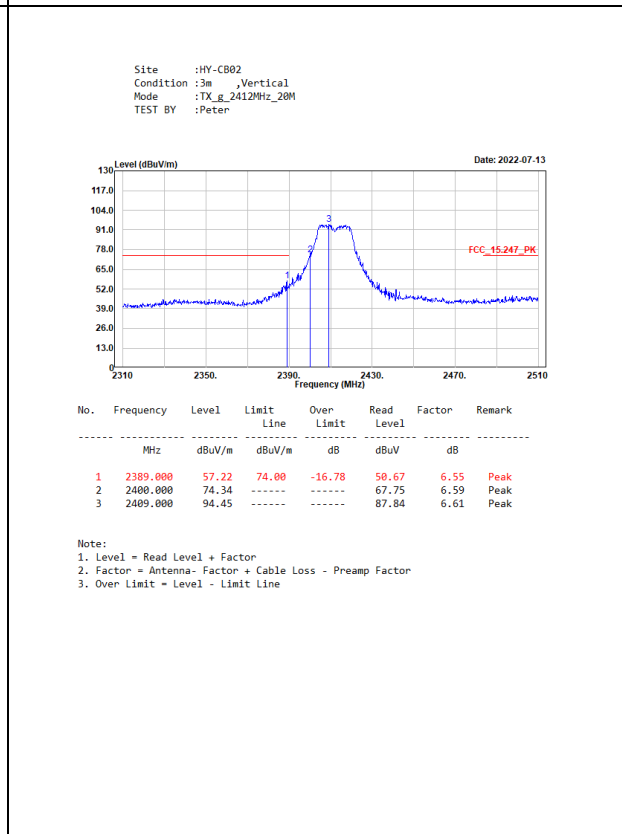
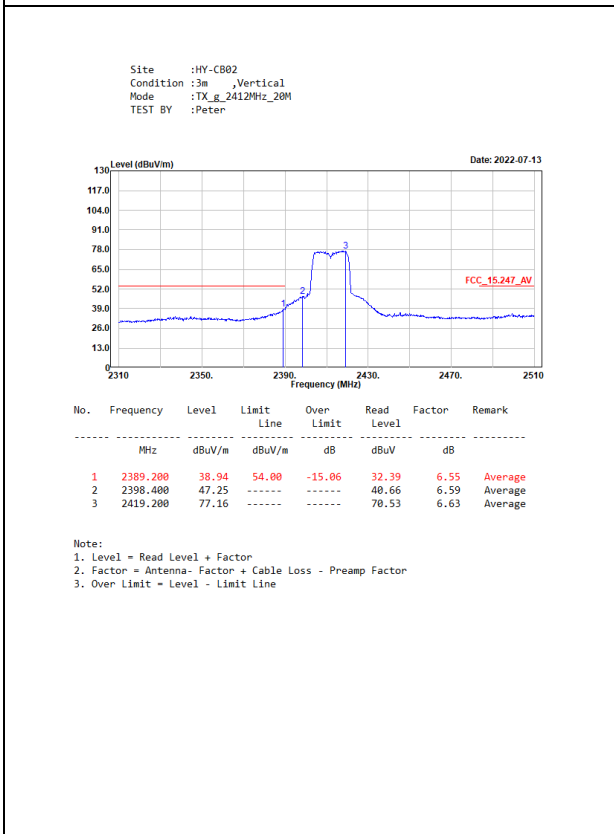
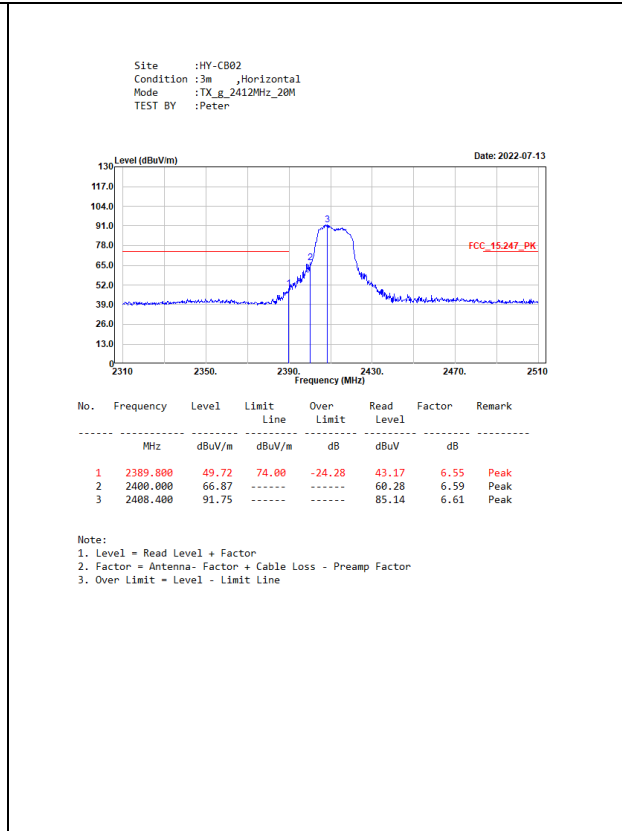
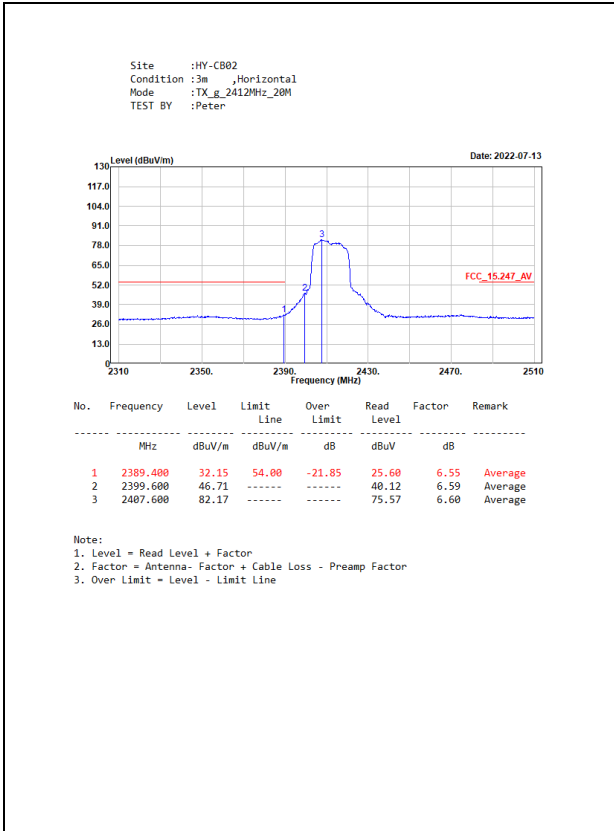

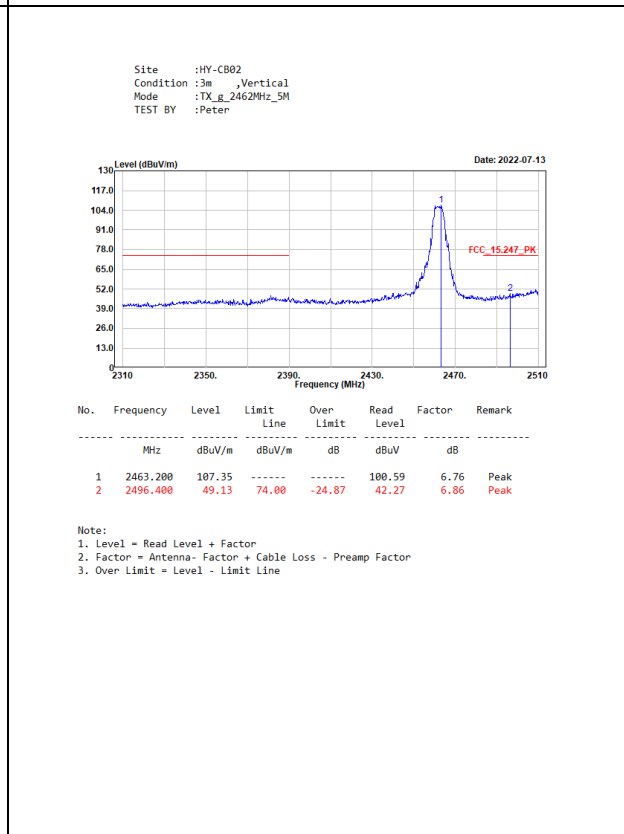
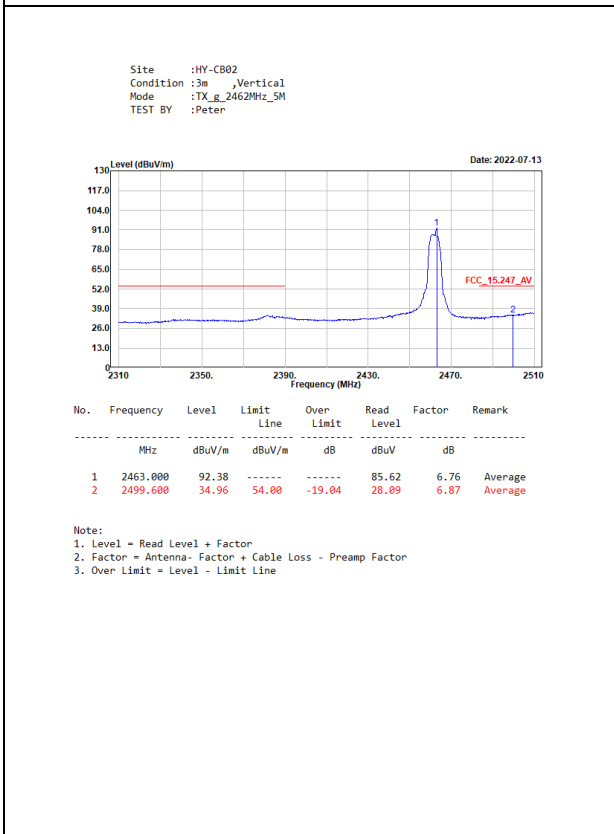
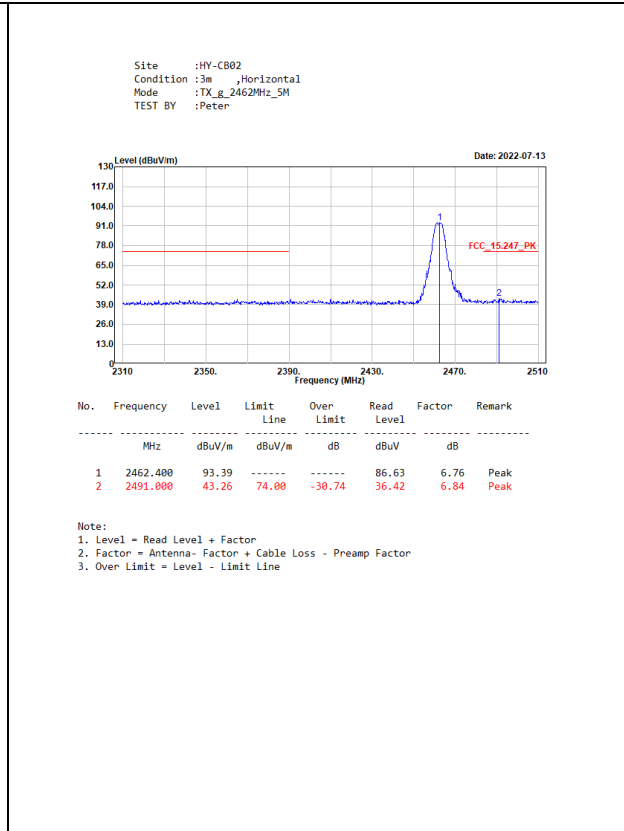
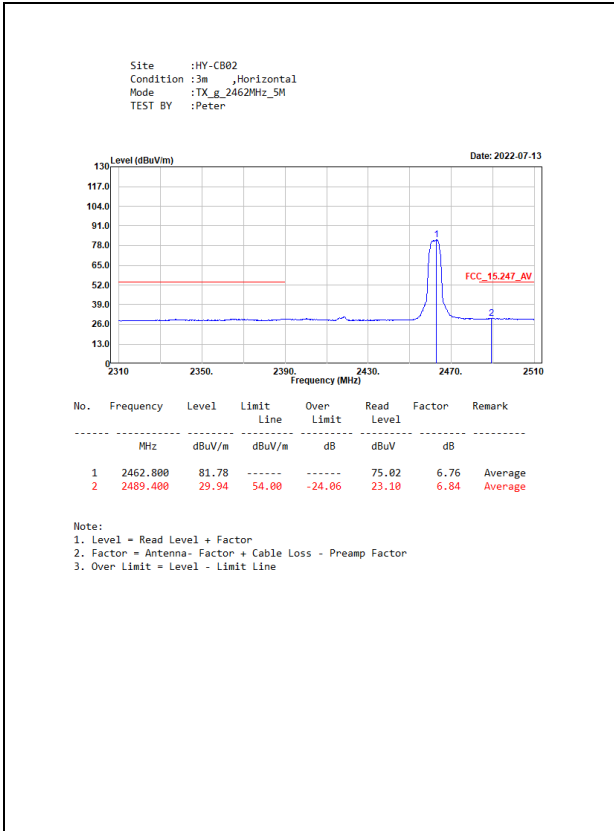

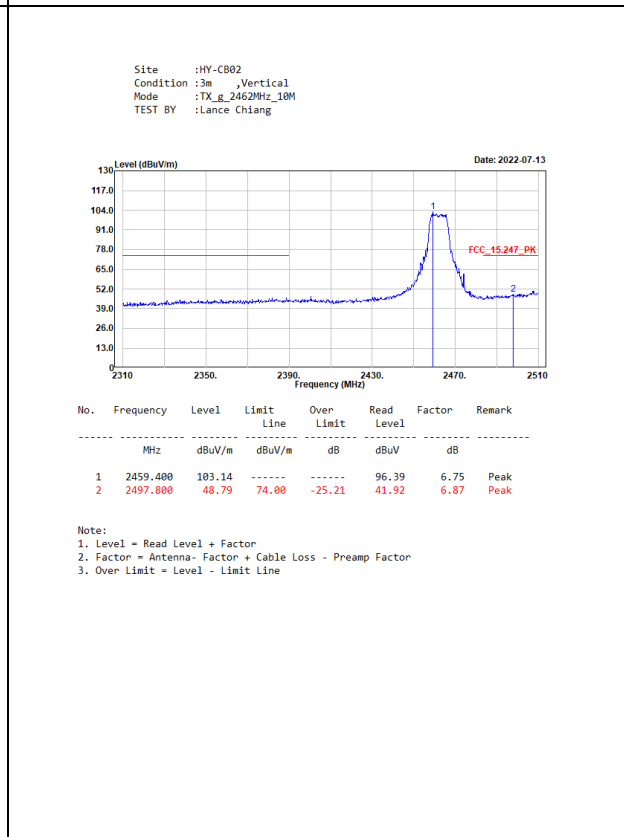
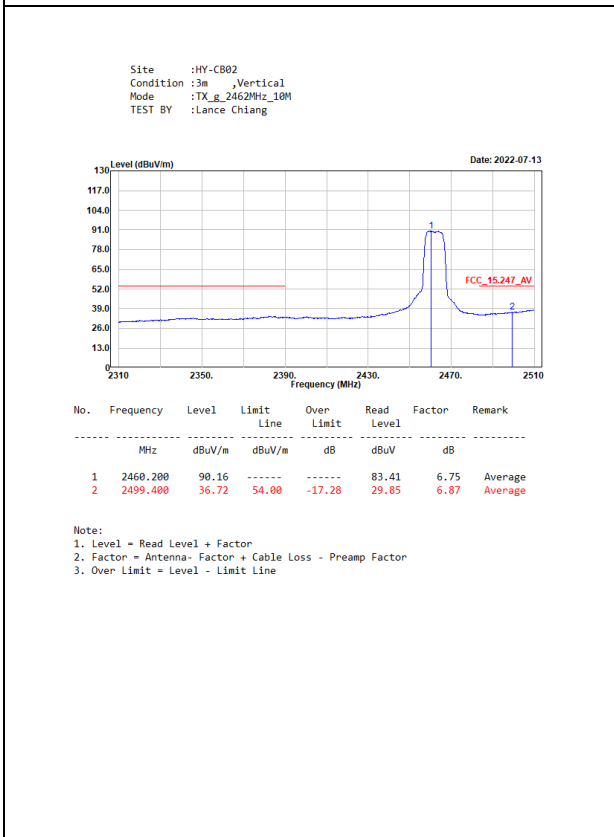
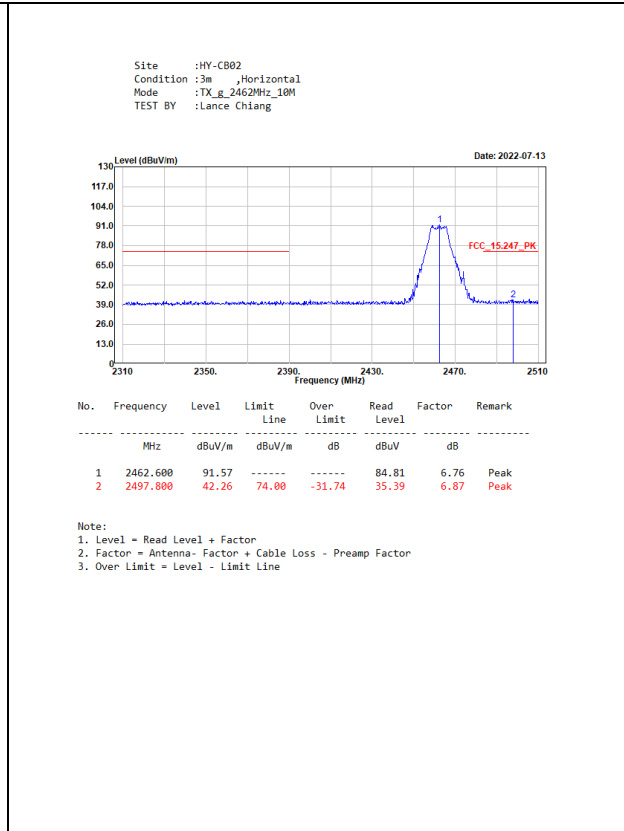
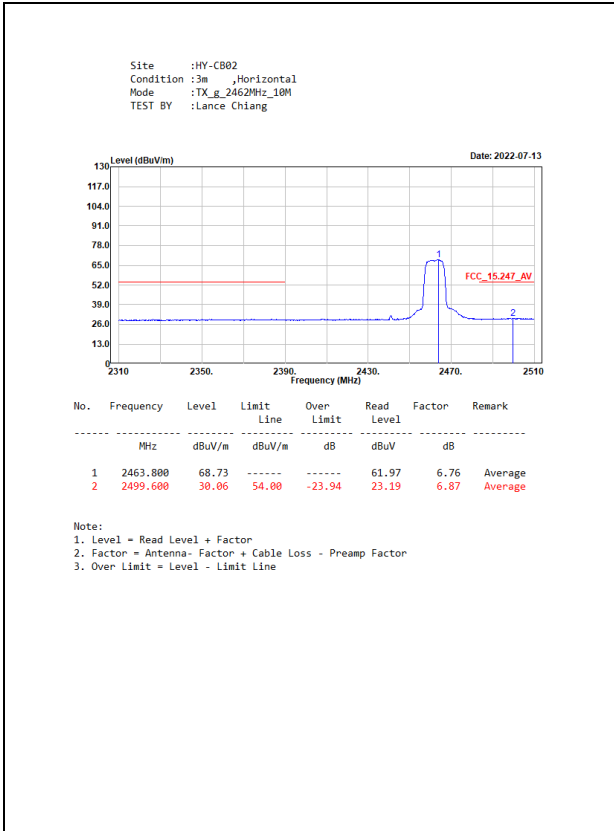

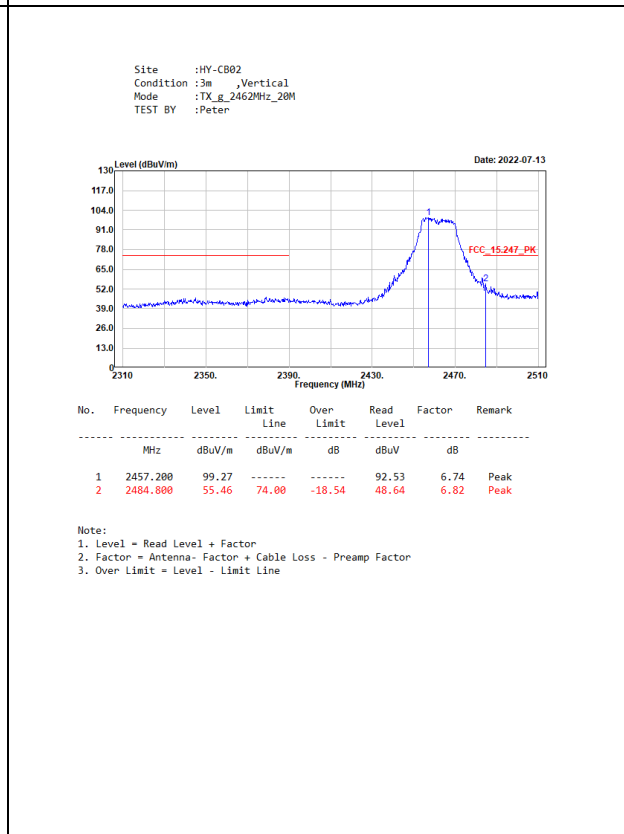
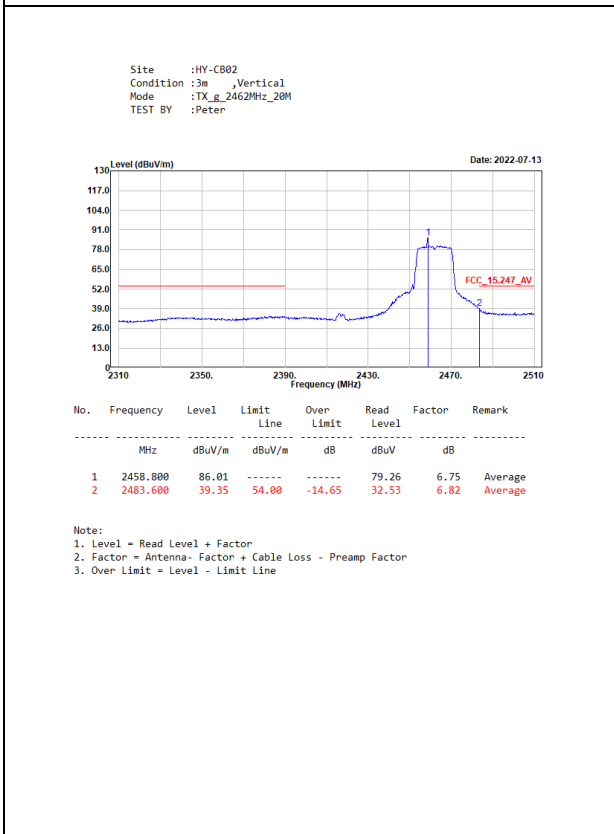
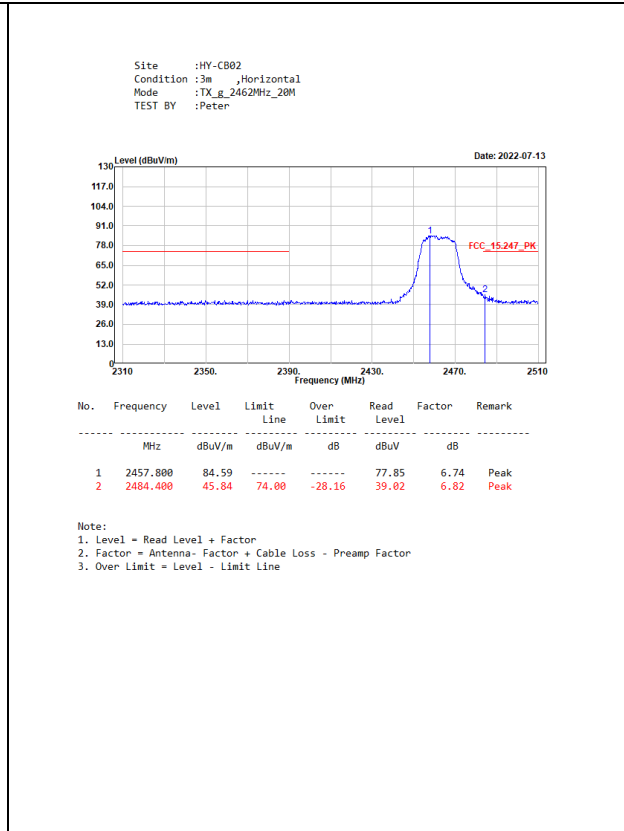
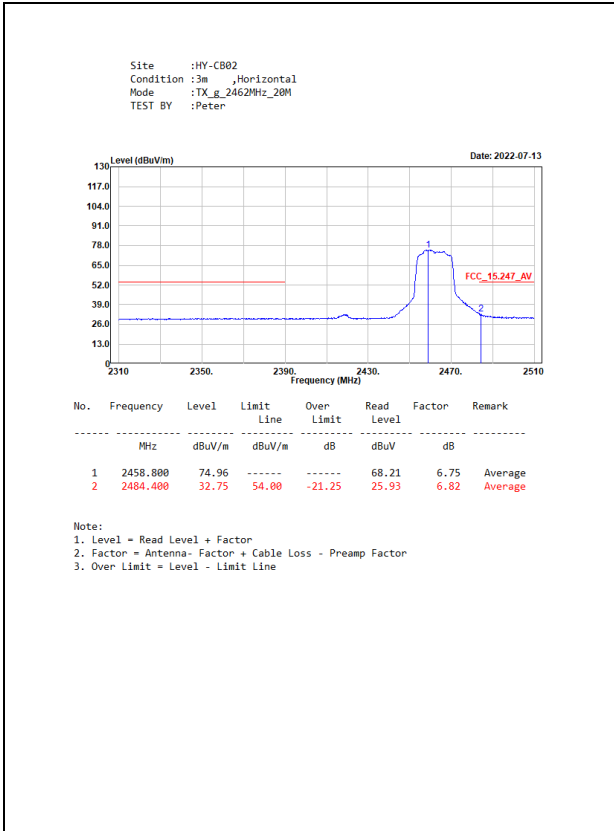

SISO A Panel

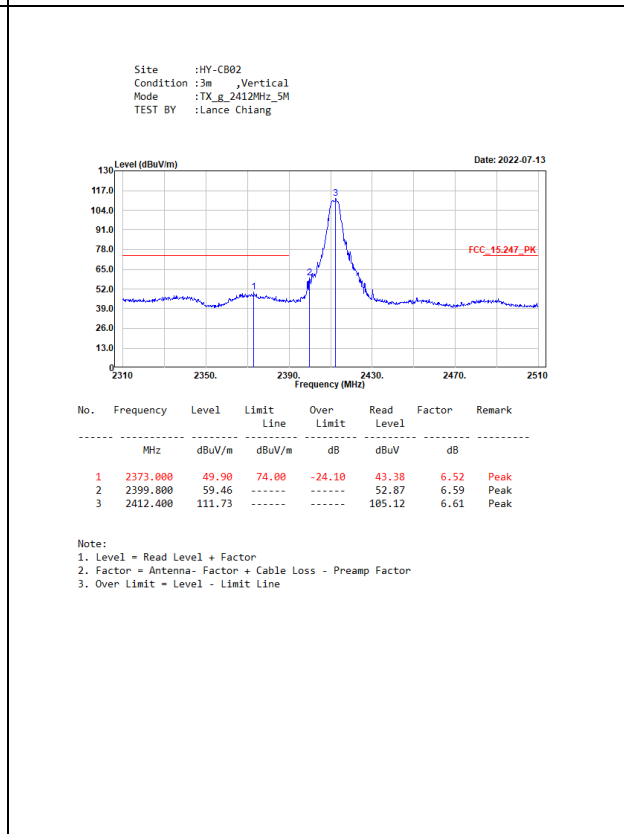
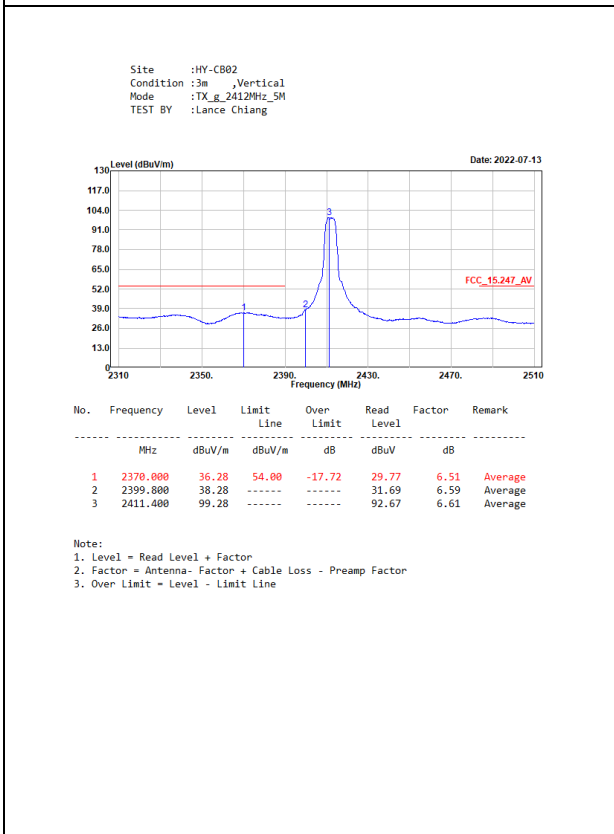
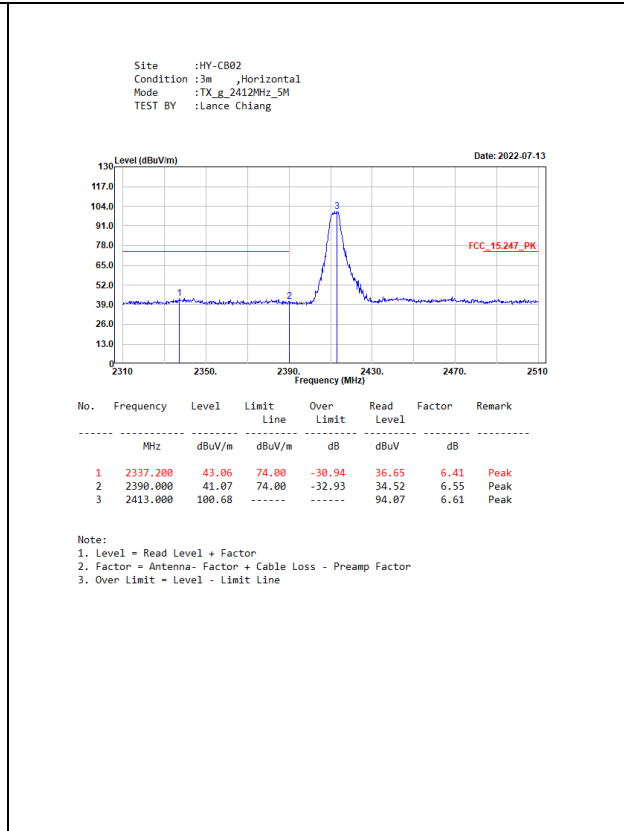
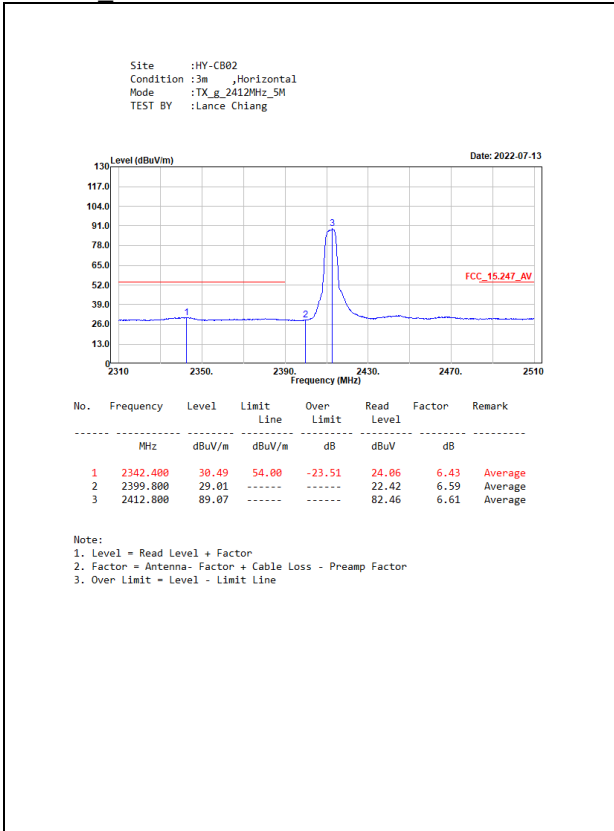

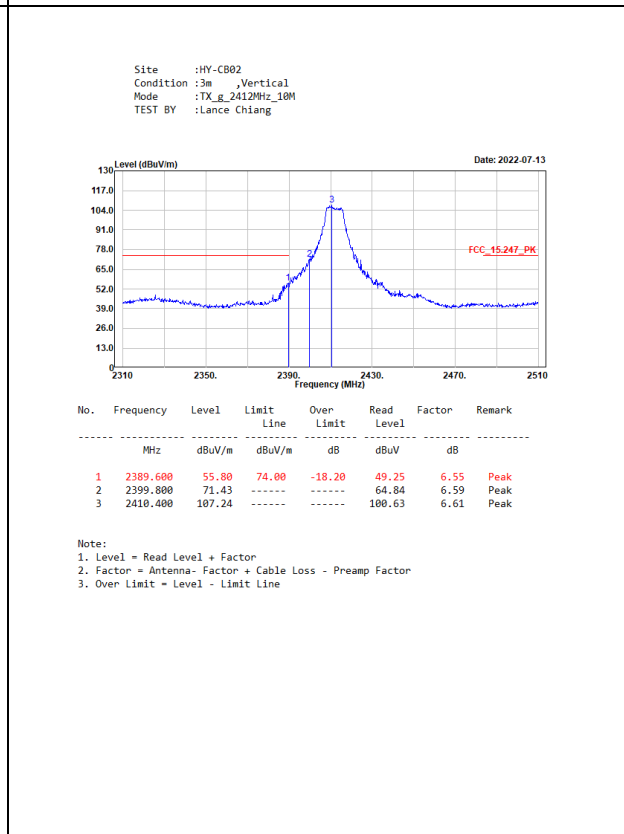
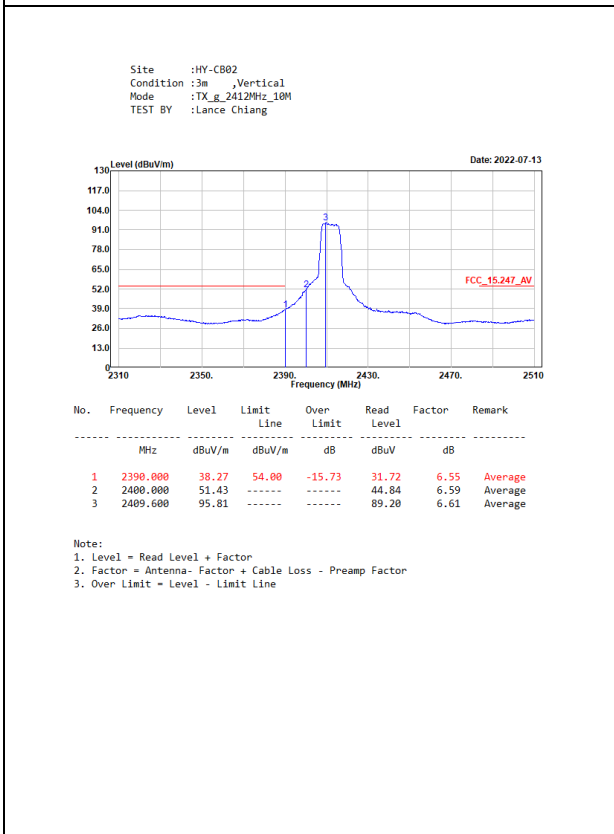
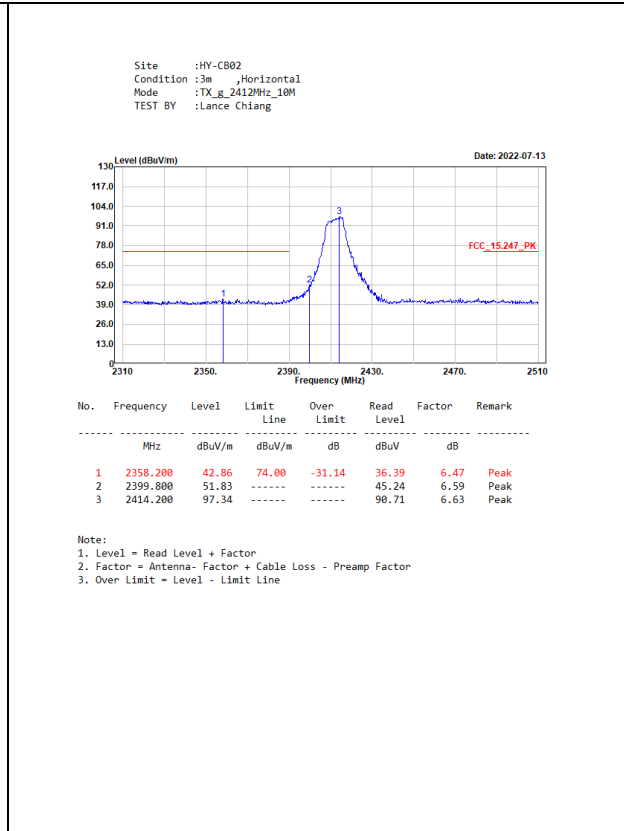
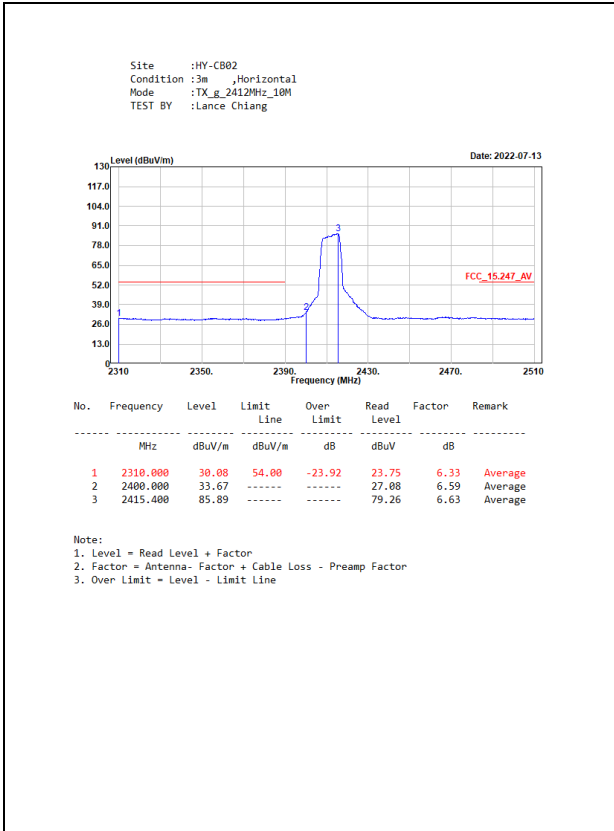

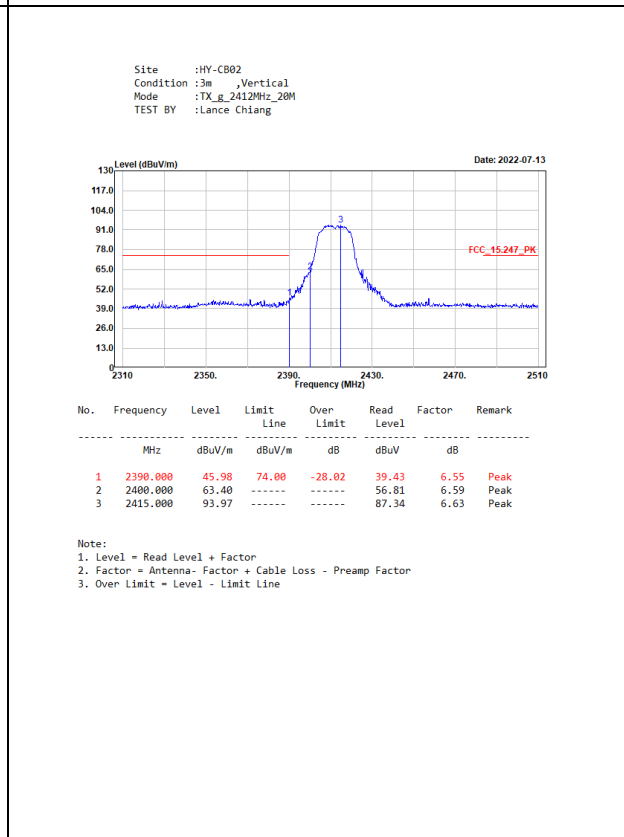
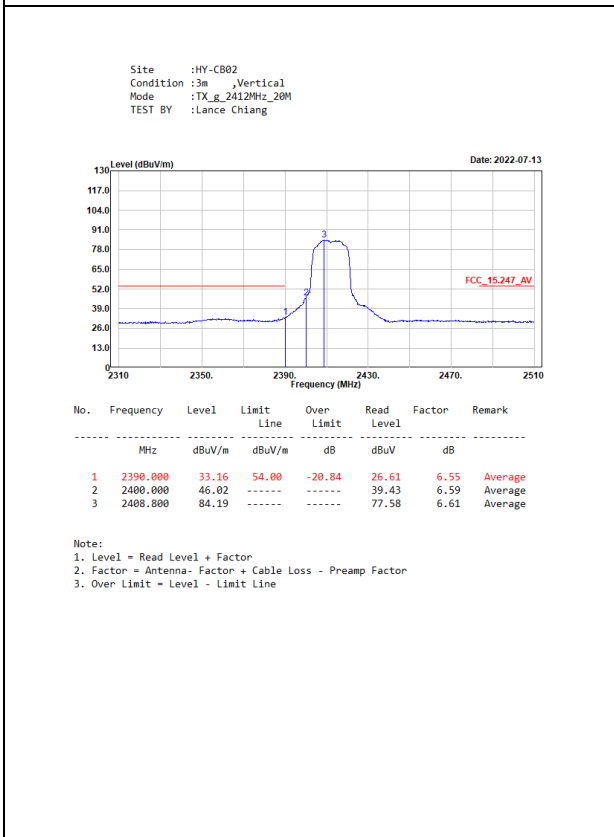
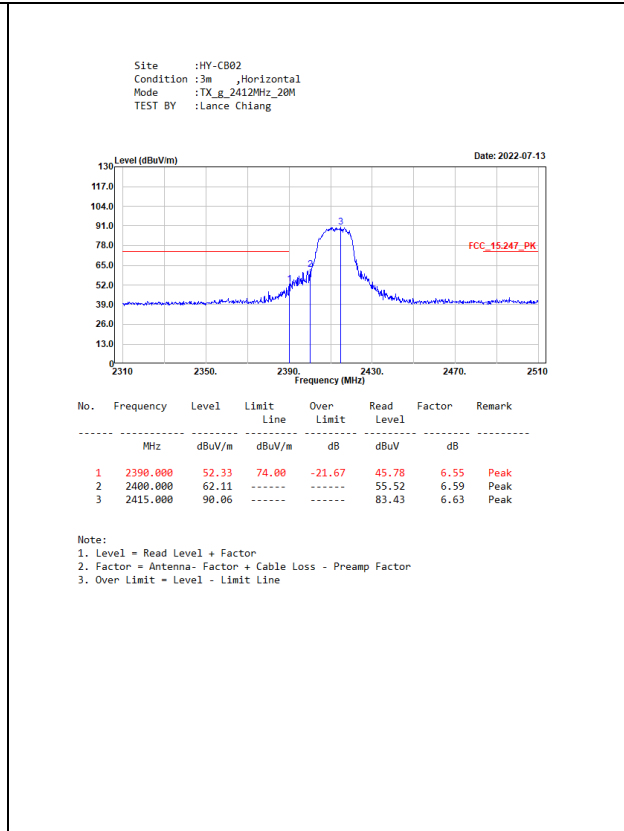
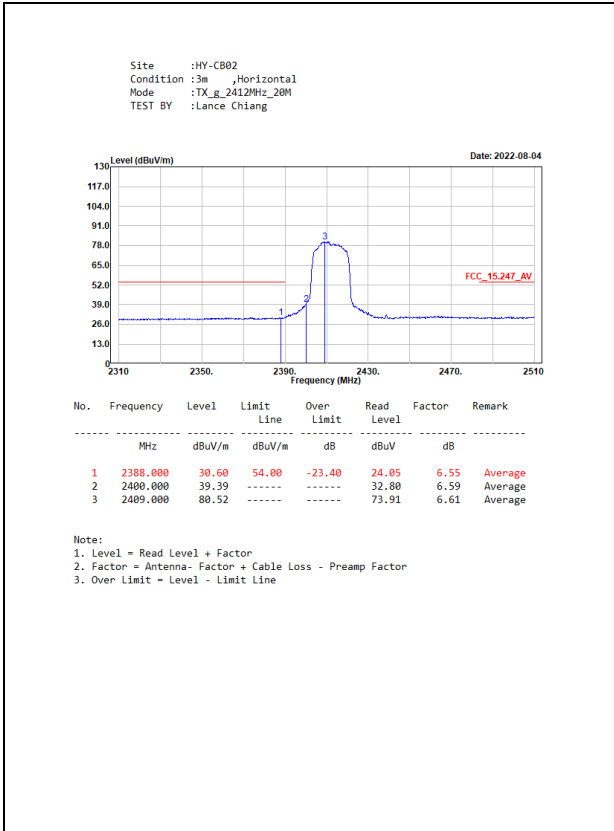

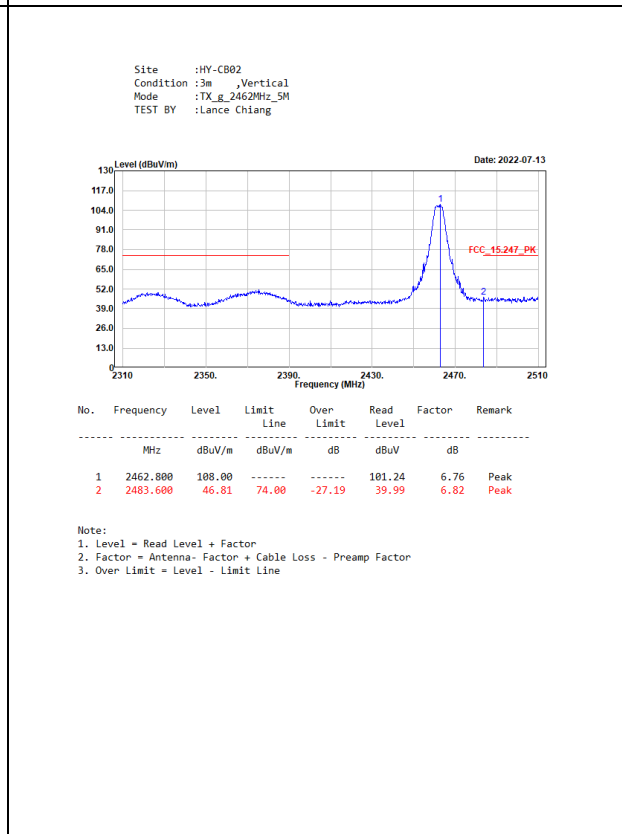
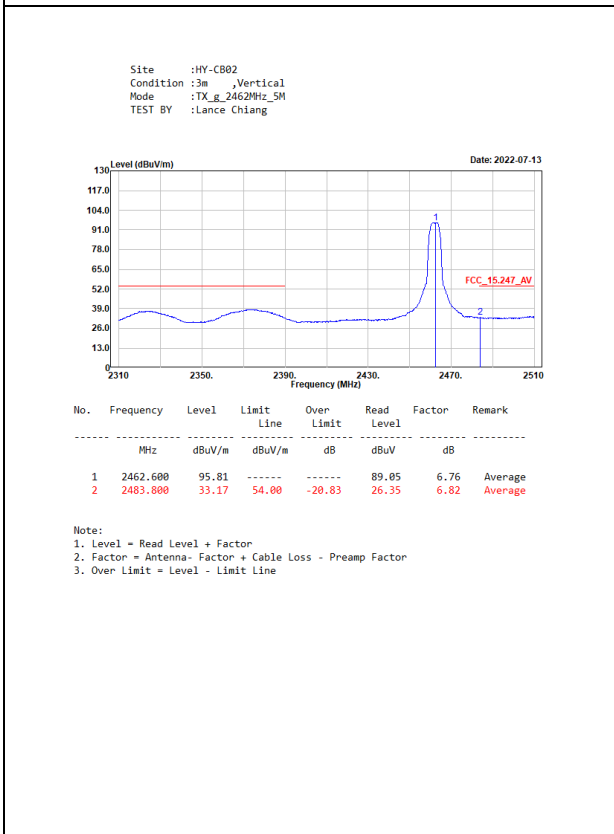
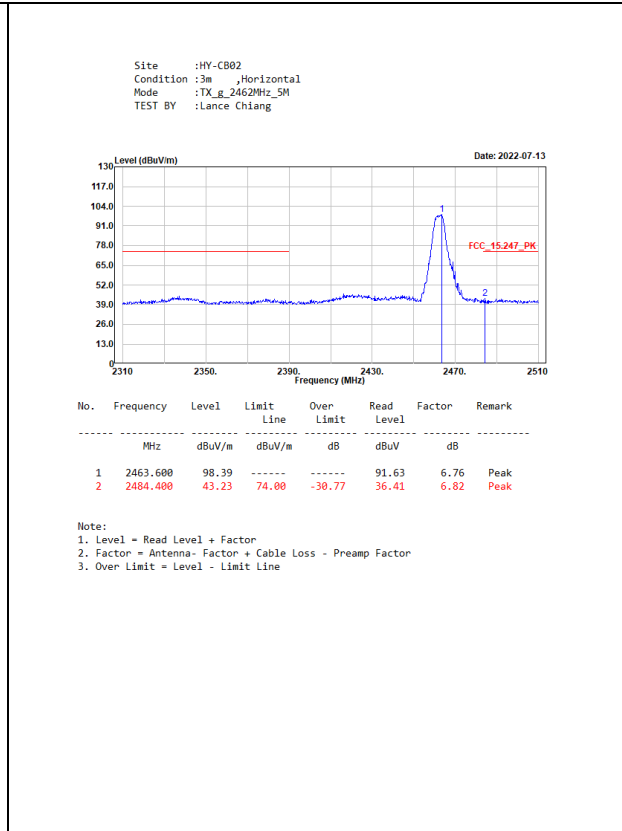
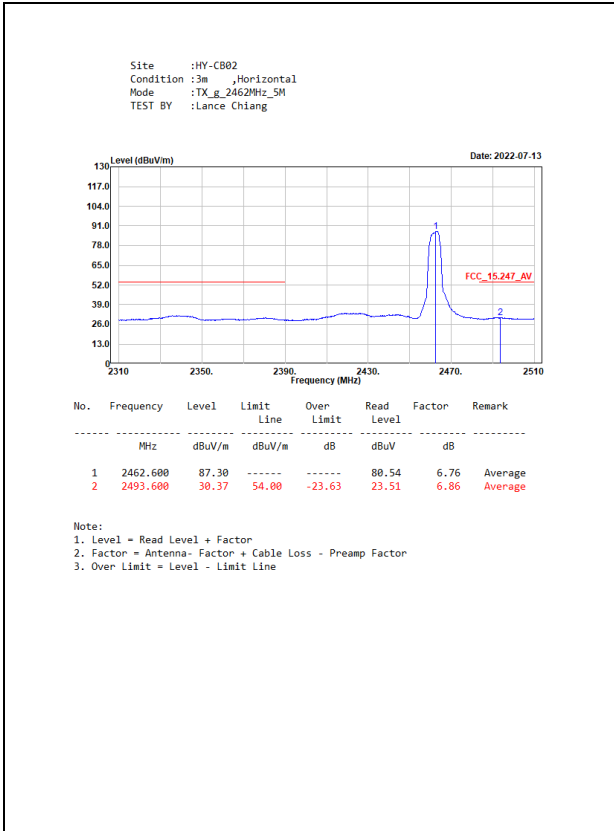

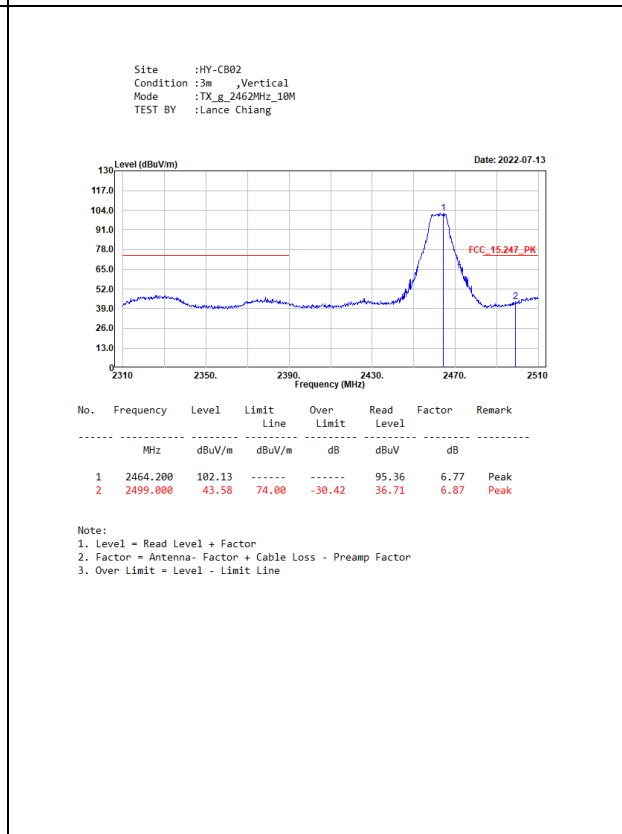
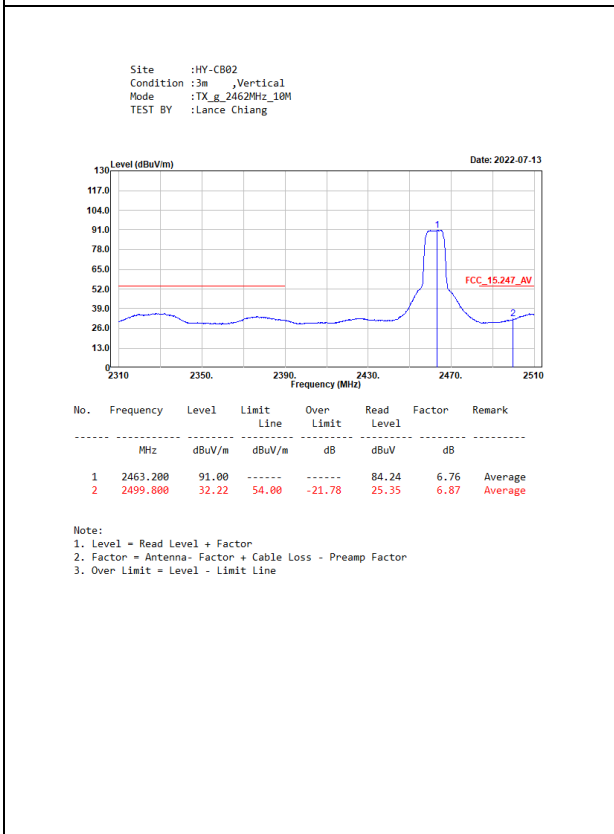
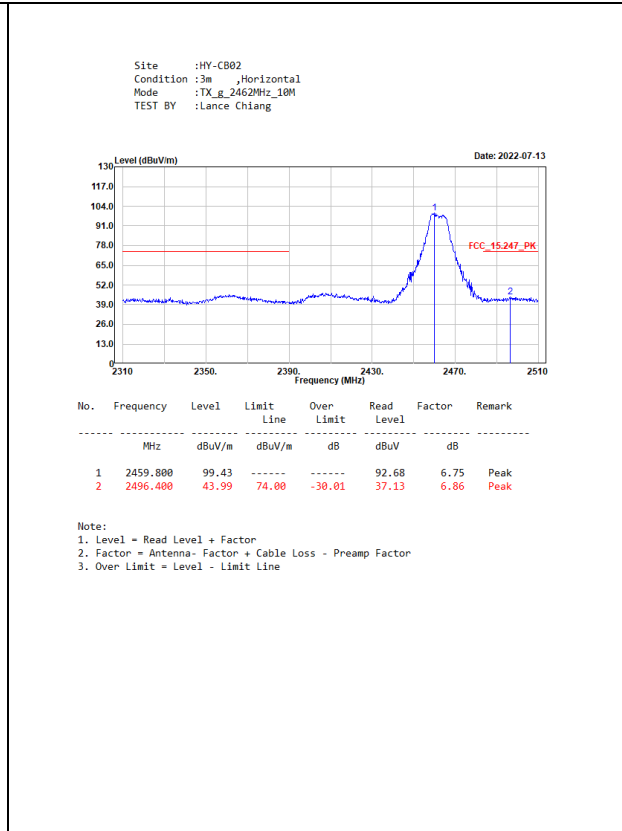
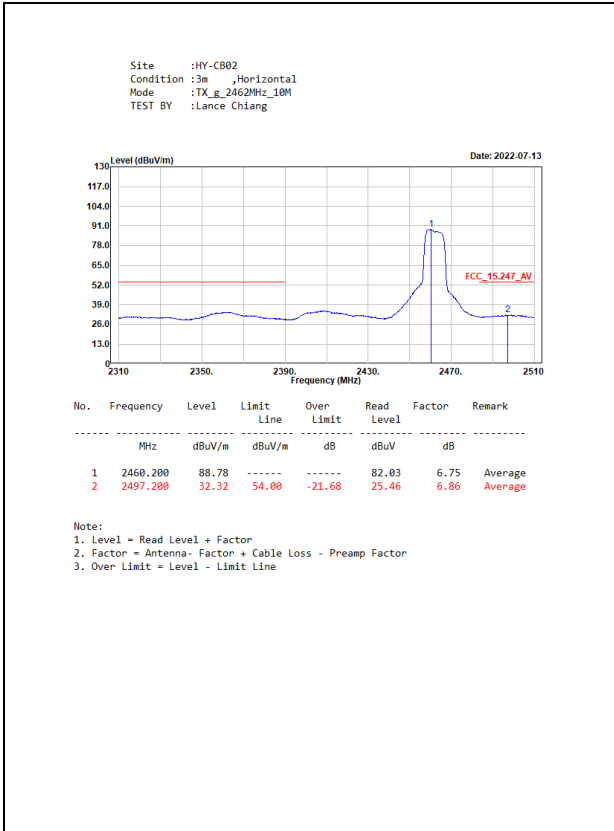

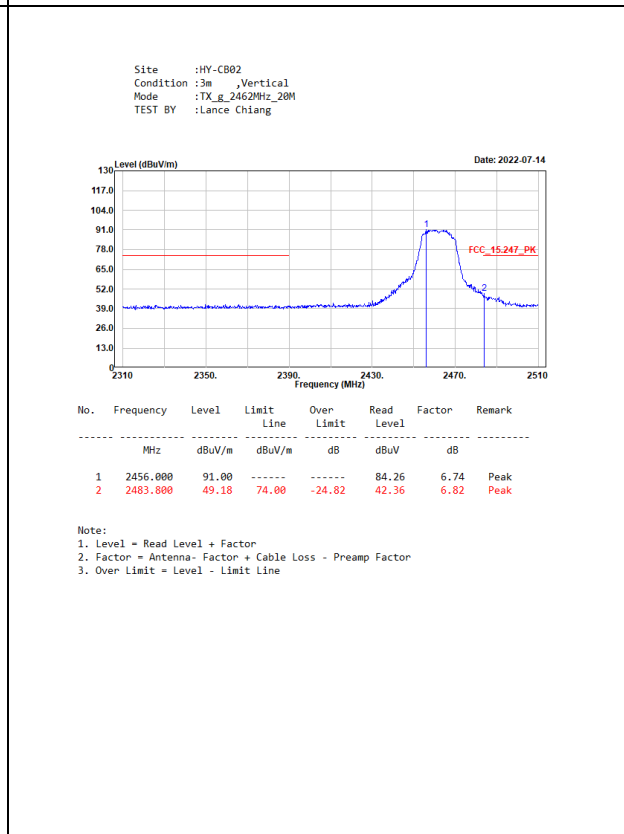
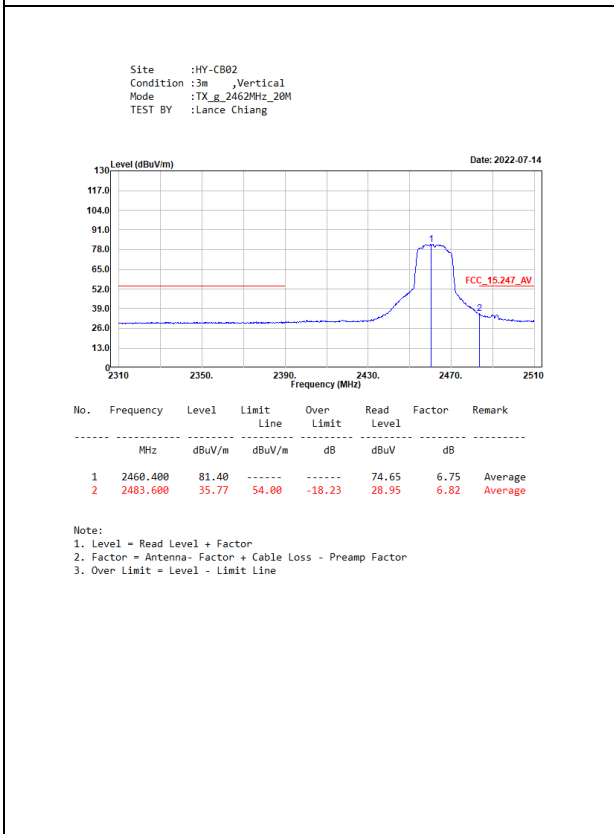
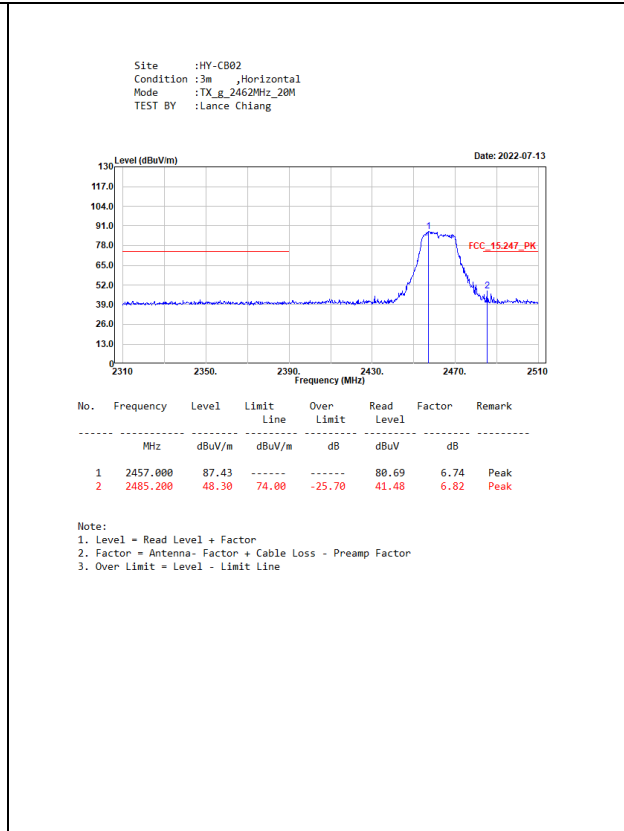
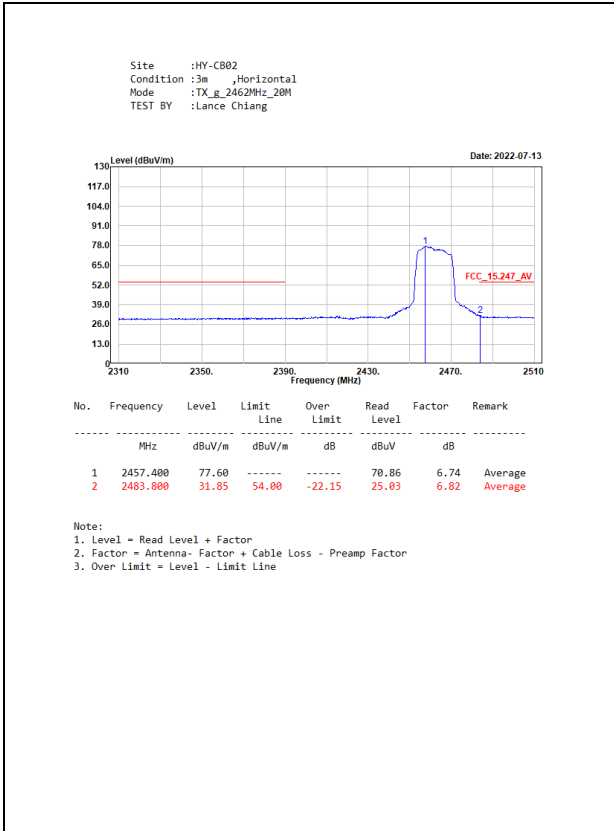

7. 6dB Bandwidth

7.1. Test Setup

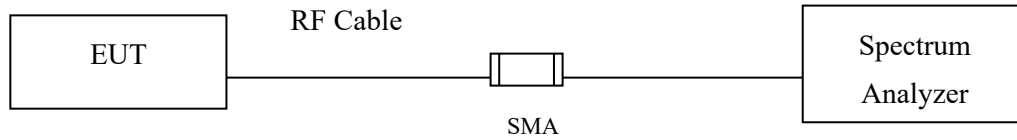

7.2. Limits

The minimum bandwidth shall be at least 500 kHz.

7.3. Test Procedure

The EUT was setup according to ANSI C63.4, 2014; tested according to ANSI C63.10 Section 11.8 for compliance to FCC 47CFR 15.247 requirements.

7.4. Test Result of 6dB Bandwidth

Product : Wireless AP / Bridge / Client
 Test Item : 6dB Bandwidth Data
 Test Mode : Mode 1: SISO A Transmit (802.11g 6Mbps)_5M_Dipole

Channel No.	Frequency (MHz)	Measurement Level (kHz)	Required Limit (kHz)	Result
01	2412	4200	>500	Pass
06	2437	4200	>500	Pass
11	2462	4250	>500	Pass

Figure Channel 01:

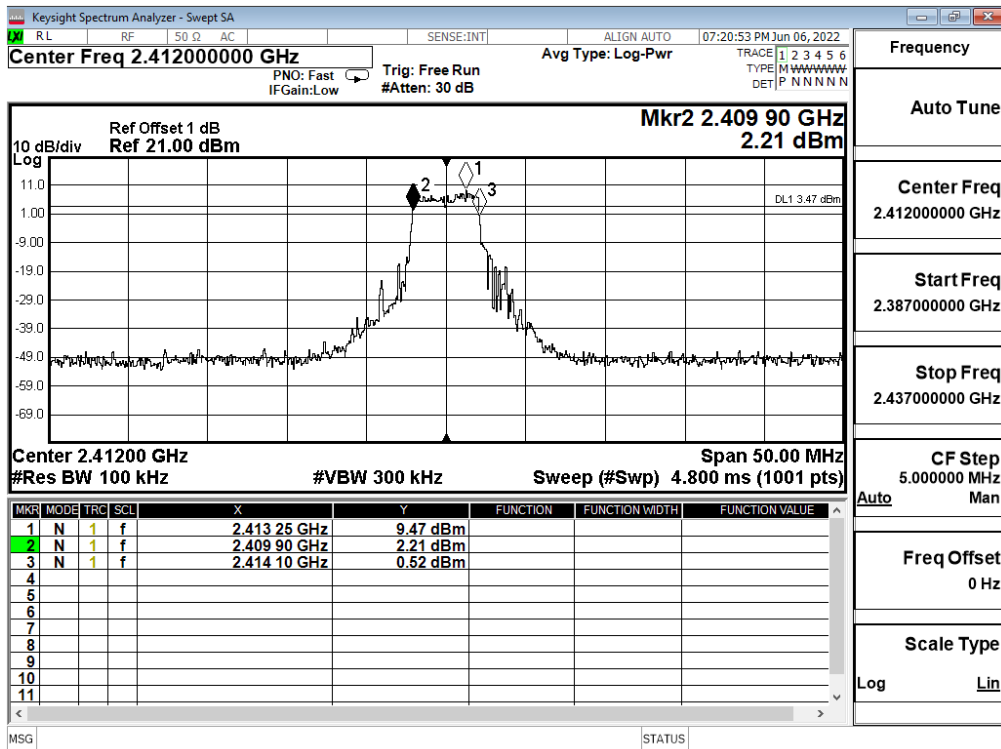

Product : Wireless AP / Bridge / Client
 Test Item : 6dB Bandwidth Data
 Test Mode : Mode 2: SISO A Transmit (802.11g 6Mbps)_10M_Dipole

Channel No.	Frequency (MHz)	Measurement Level (kHz)	Required Limit (kHz)	Result
01	2412	8300	>500	Pass
06	2437	8250	>500	Pass
11	2462	8300	>500	Pass

Figure Channel 06:

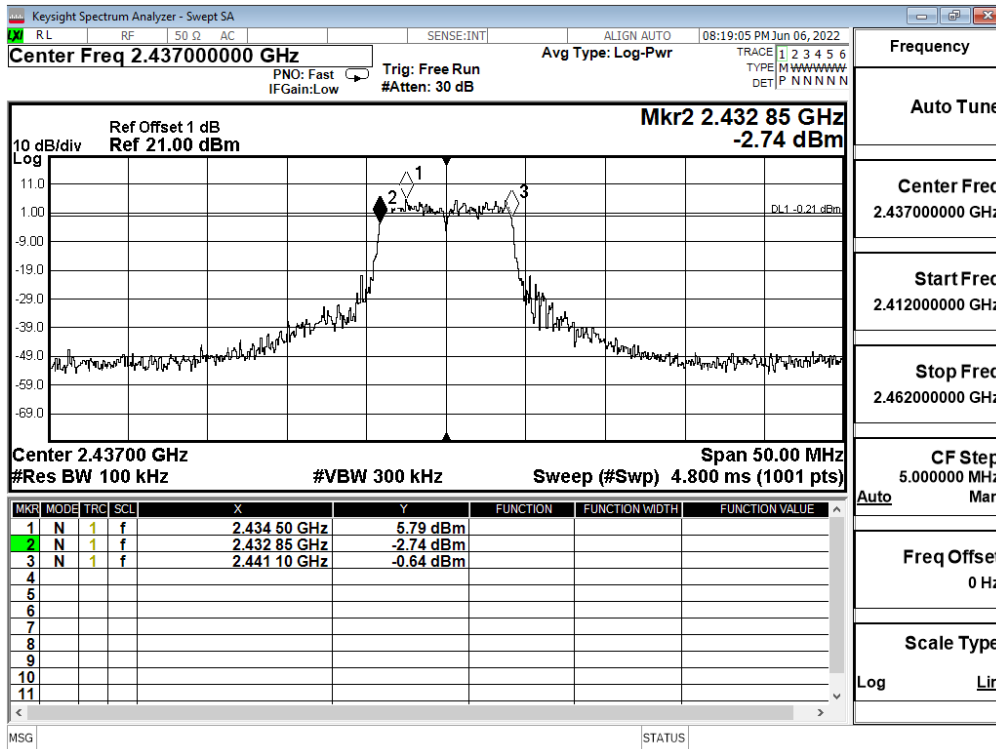

Product : Wireless AP / Bridge / Client
 Test Item : 6dB Bandwidth Data
 Test Mode : Mode 3: SISO A Transmit (802.11g 6Mbps)_20M_Dipole

Channel No.	Frequency (MHz)	Measurement Level (kHz)	Required Limit (kHz)	Result
01	2412	16150	>500	Pass
06	2437	16350	>500	Pass
11	2462	16400	>500	Pass

Figure Channel 01:

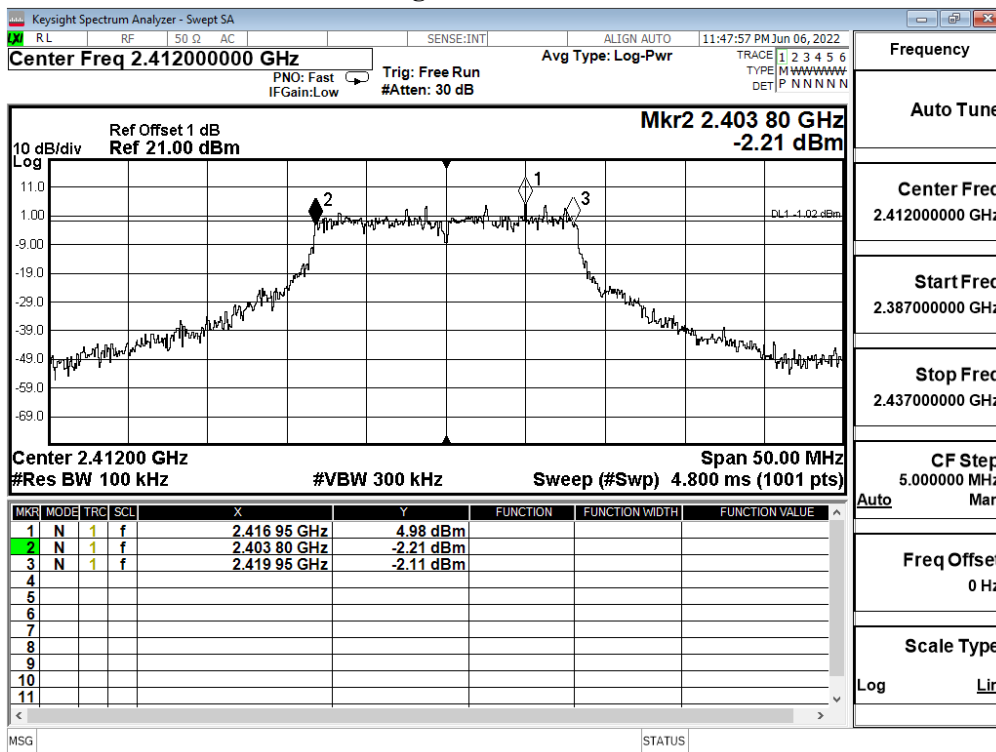

Product : Wireless AP / Bridge / Client
 Test Item : 6dB Bandwidth Data
 Test Mode : Mode 1: SISO A Transmit (802.11g 6Mbps)_5M_Panel

Channel No.	Frequency (MHz)	Measurement Level (kHz)	Required Limit (kHz)	Result
01	2412	4200	>500	Pass
06	2437	4200	>500	Pass
11	2462	4250	>500	Pass

Figure Channel 11:

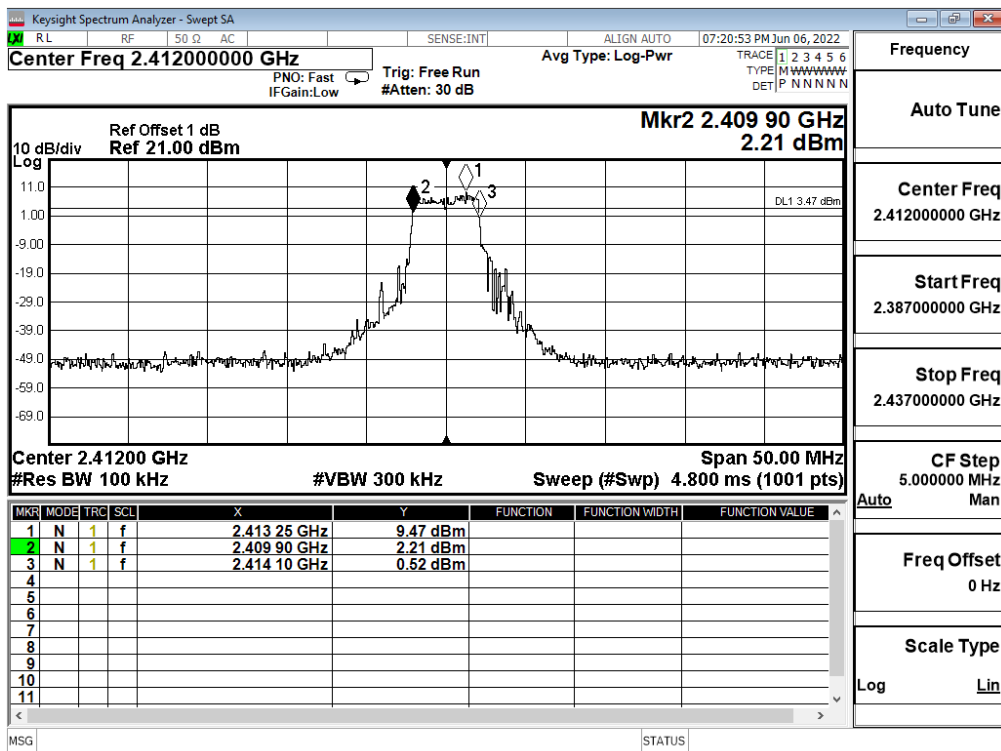

Product : Wireless AP / Bridge / Client
 Test Item : 6dB Bandwidth Data
 Test Mode : Mode 2: SISO A Transmit (802.11g 6Mbps)_10M_Panel

Channel No.	Frequency (MHz)	Measurement Level (kHz)	Required Limit (kHz)	Result
01	2412	8300	>500	Pass
06	2437	8250	>500	Pass
11	2462	8300	>500	Pass

Figure Channel 06:

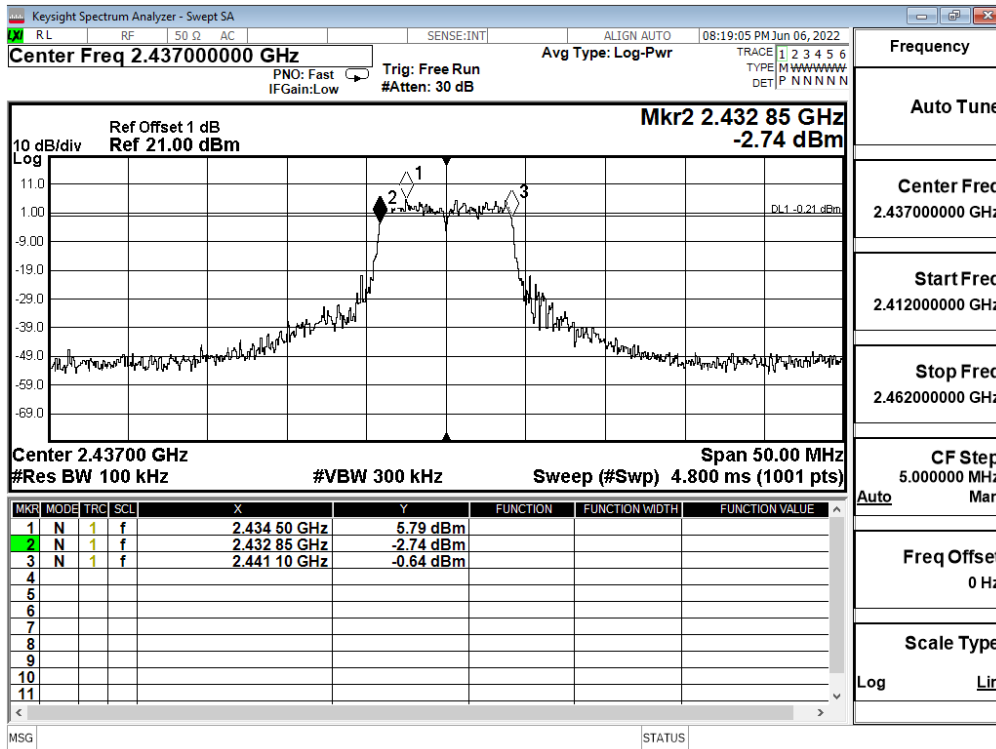

Product : Wireless AP / Bridge / Client
 Test Item : 6dB Bandwidth Data
 Test Mode : Mode 3: SISO A Transmit (802.11g 6Mbps)_20M_Panel

Channel No.	Frequency (MHz)	Measurement Level (kHz)	Required Limit (kHz)	Result
01	2412	16150	>500	Pass
06	2437	16350	>500	Pass
11	2462	16400	>500	Pass

Figure Channel 01:

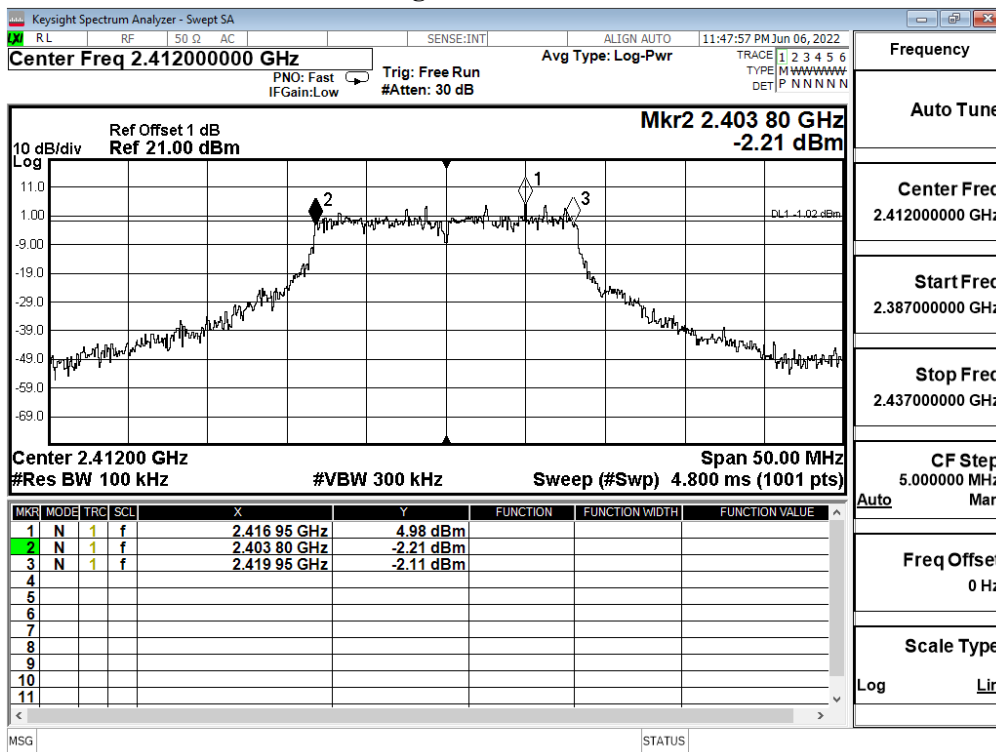

8. Power Density

8.1. Test Setup

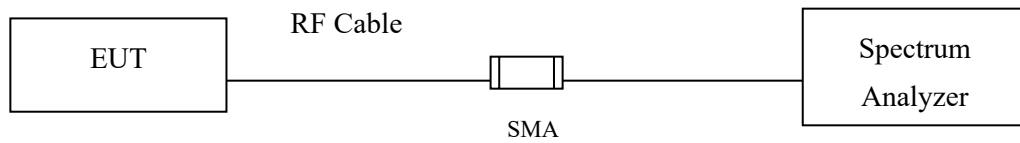

8.2. Limits

The transmitted power density averaged over any 1 second interval shall not be greater +8dBm in any 3kHz bandwidth.

8.3. Test Procedure

The EUT was setup according to ANSI C63.10, 2013; tested according to DTS test procedure of KDB 558074 for compliance to FCC 47CFR 15.247 requirements.

The maximum power spectral density using C63.10 Section 11.10.2 Method PKPSD (peak PSD)

8.4. Test Result of Power Density

Product : Wireless AP / Bridge / Client
 Test Item : Power Density Data
 Test Mode : Mode 1: SISO A Transmit (802.11g 6Mbps)_5M_Dipole

Channel No.	Frequency (MHz)	Measure Level (dBm)	Limit (dBm)	Result
01	2412	-2.177	≤ 6.6dBm	Pass
06	2437	-1.967	≤ 6.6dBm	Pass
11	2462	-1.475	≤ 6.6dBm	Pass

Figure Channel 11:

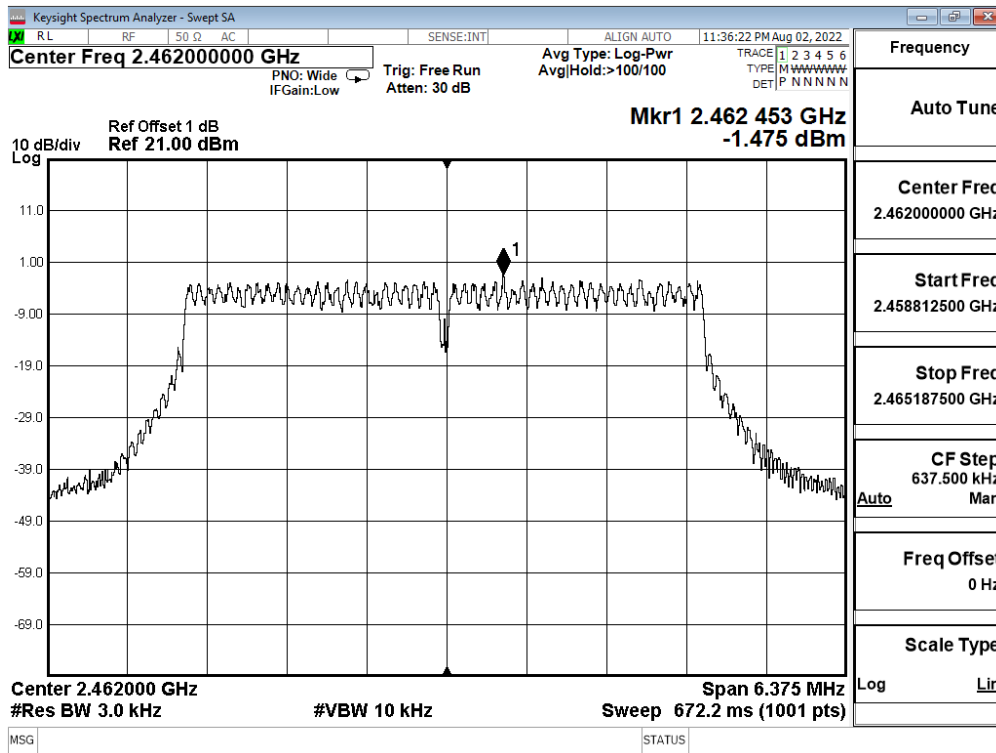

Product : Wireless AP / Bridge / Client
 Test Item : Power Density Data
 Test Mode : Mode 2: SISO A Transmit (802.11g 6Mbps)_10M_Dipole

Channel No.	Frequency (MHz)	Measure Level (dBm)	Limit (dBm)	Result
01	2412	-5.152	≤ 6.6dBm	Pass
06	2437	-4.846	≤ 6.6dBm	Pass
11	2462	-5.155	≤ 6.6dBm	Pass

Figure Channel 06:

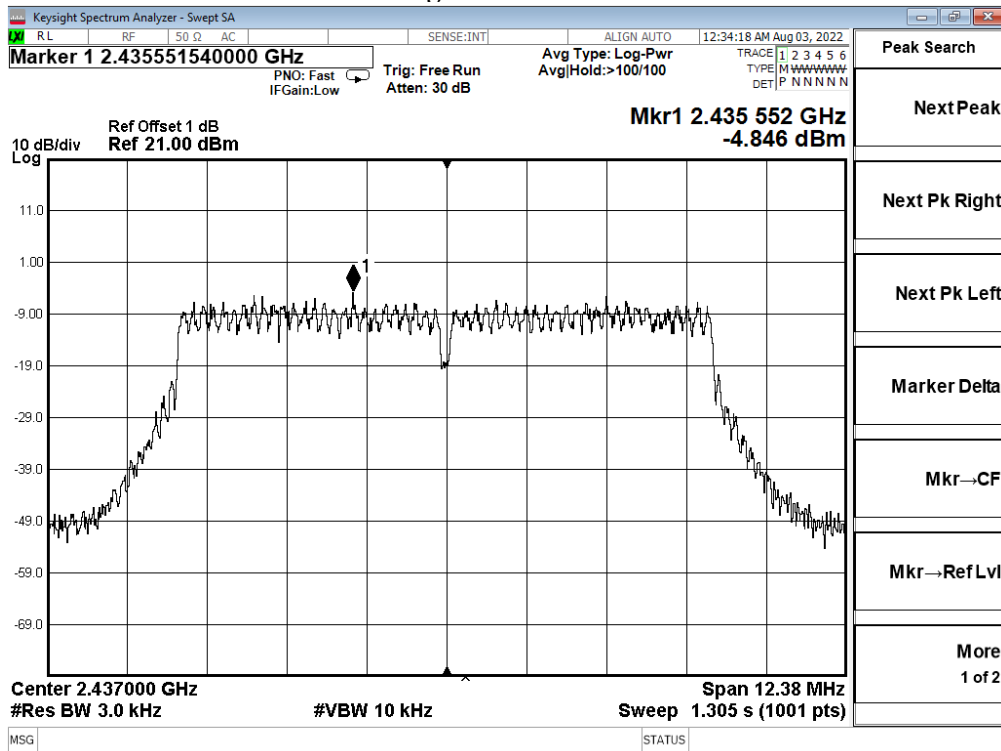

Product : Wireless AP / Bridge / Client
 Test Item : Power Density Data
 Test Mode : Mode 3: SISO A Transmit (802.11g 6Mbps)_20M_Dipole

Channel No.	Frequency (MHz)	Measure Level (dBm)	Limit (dBm)	Result
01	2412	4.820	≤ 6.6dBm	Pass
06	2437	4.800	≤ 6.6dBm	Pass
11	2462	4.130	≤ 6.6dBm	Pass

Figure Channel 01:

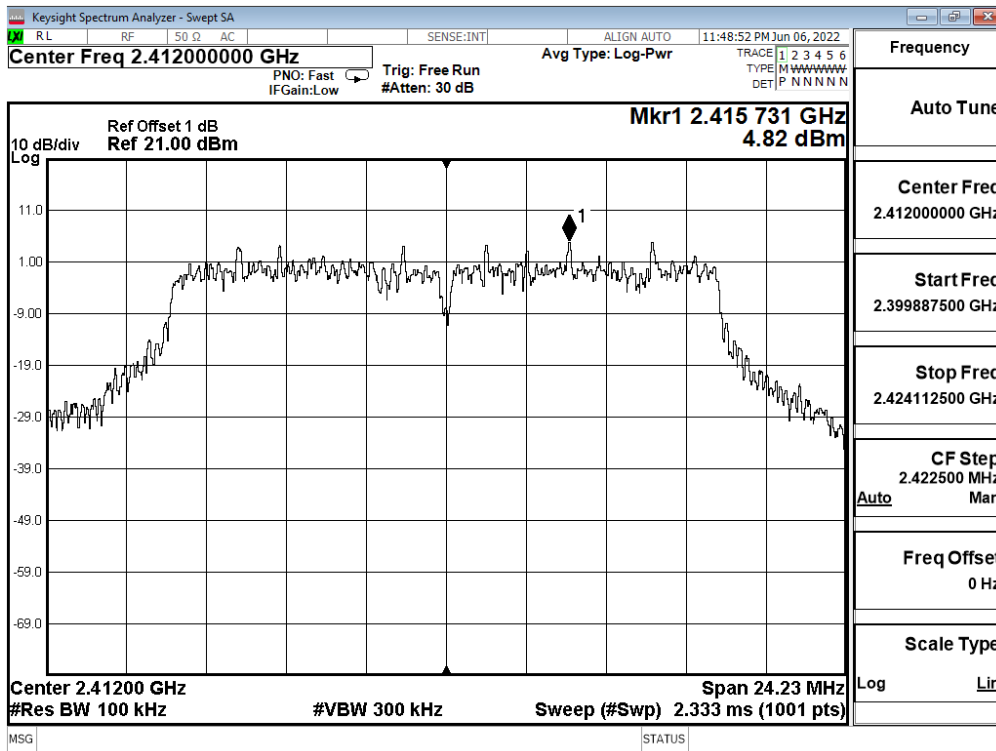

Product : Wireless AP / Bridge / Client
 Test Item : Power Density Data
 Test Mode : Mode 1: SISO A Transmit (802.11g 6Mbps)_5M_Panel

Channel No.	Frequency (MHz)	Measure Level (dBm)	Limit (dBm)	Result
01	2412	-2.177	≤ 6dBm	Pass
06	2437	-1.967	≤ 6dBm	Pass
11	2462	-1.475	≤ 6dBm	Pass

Figure Channel 11:

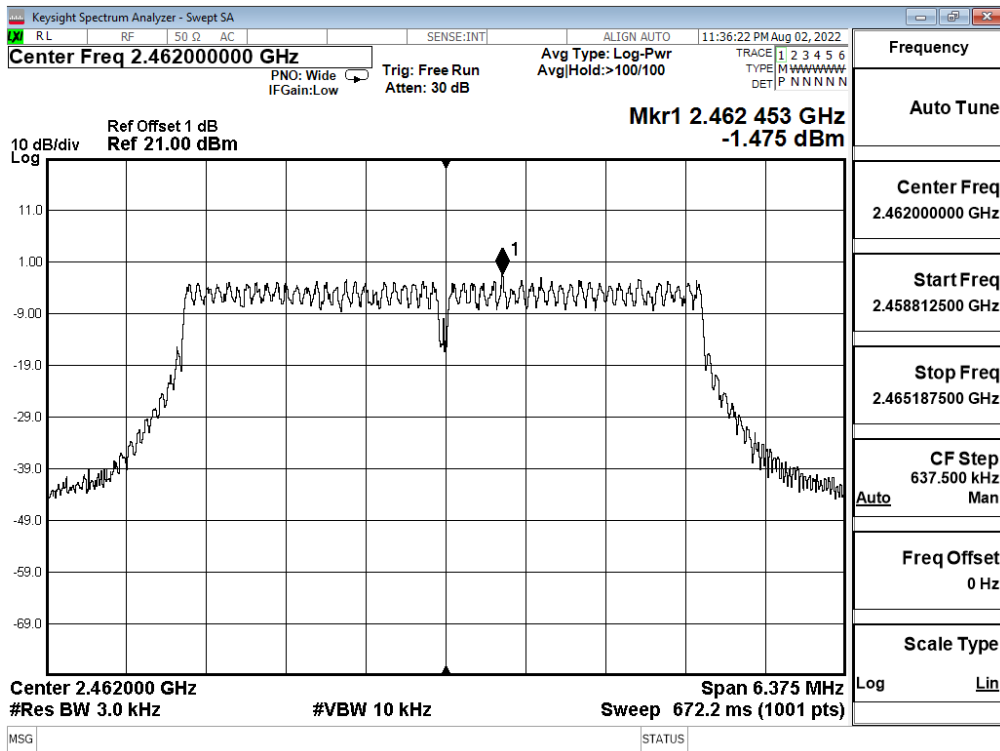

Product : Wireless AP / Bridge / Client
 Test Item : Power Density Data
 Test Mode : Mode 2: SISO A Transmit (802.11g 6Mbps)_10M_Panel

Channel No.	Frequency (MHz)	Measure Level (dBm)	Limit (dBm)	Result
01	2412	-5.152	≤ 6dBm	Pass
06	2437	-4.846	≤ 6dBm	Pass
11	2462	-5.155	≤ 6dBm	Pass

Figure Channel 06:

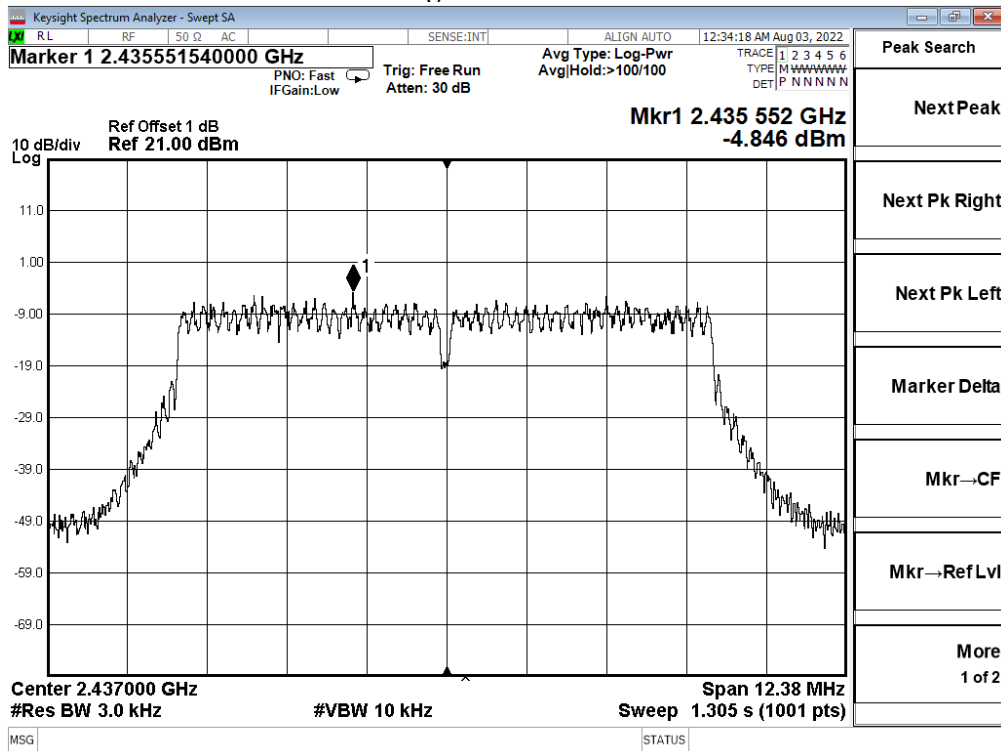

Product : Wireless AP / Bridge / Client
 Test Item : Power Density Data
 Test Mode : Mode 3: SISO A Transmit (802.11g 6Mbps)_20M_Panel

Channel No.	Frequency (MHz)	Measure Level (dBm)	Limit (dBm)	Result
01	2412	4.820	≤ 6dBm	Pass
06	2437	4.800	≤ 6dBm	Pass
11	2462	4.130	≤ 6dBm	Pass

Figure Channel 01:

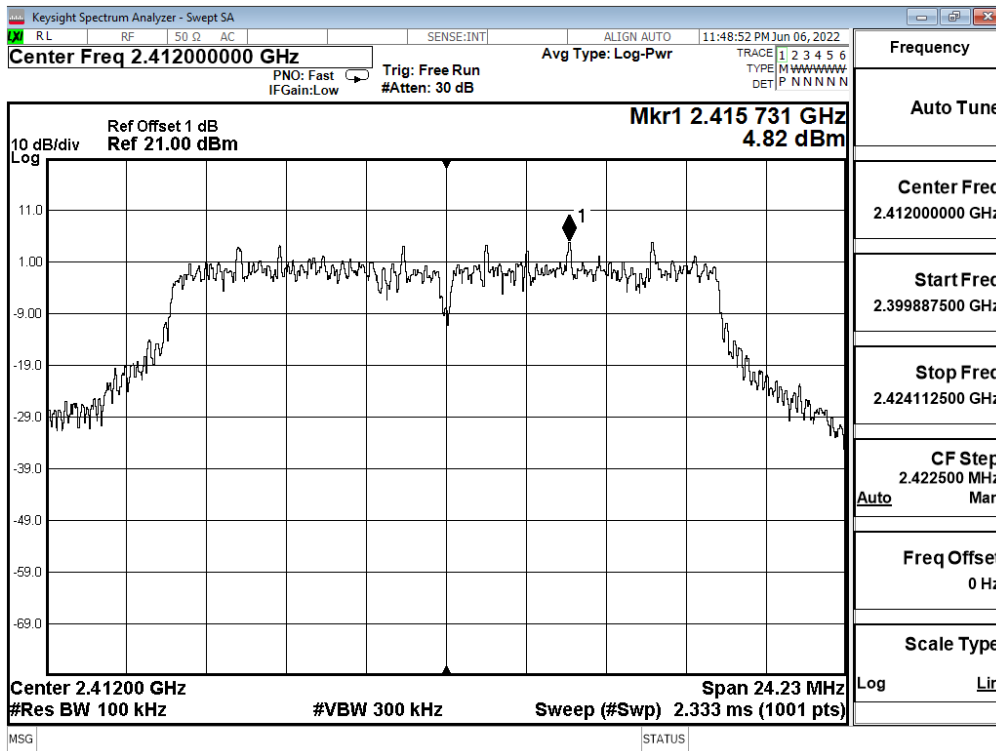

9. Duty Cycle

9.1. Test Setup

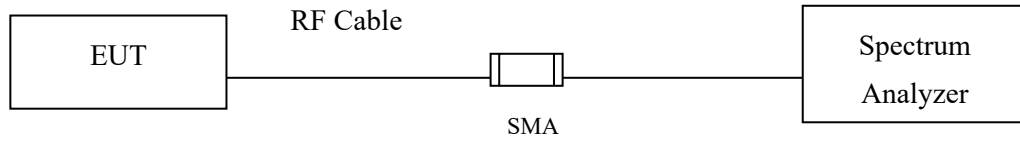

9.2. Test Procedure

The EUT was setup according to ANSI C63.10 2013; tested according to ANSI C63.10 2013 for compliance to FCC 47CFR 15.247 requirements.

9.3. Test Result of Duty Cycle

Product : Wireless AP / Bridge / Client
Test Item : Duty Cycle
Test Mode : Transmit

Duty Cycle Formula:

Duty Cycle = Ton / (Ton + Toff)

Duty Factor = 10 Log (1/Duty Cycle)

Results:

2.4GHz band	Ton (ms)	Ton + Toff (ms)	Duty Cycle (%)	Duty Factor (dB)
802.11 g 5M	1.2350	1.2990	95.07	0.22
802.11 g 10M	0.6190	0.6510	95.08	0.22
802.11 g 20M	0.3080	0.3730	82.57	0.83

802.11g 5M

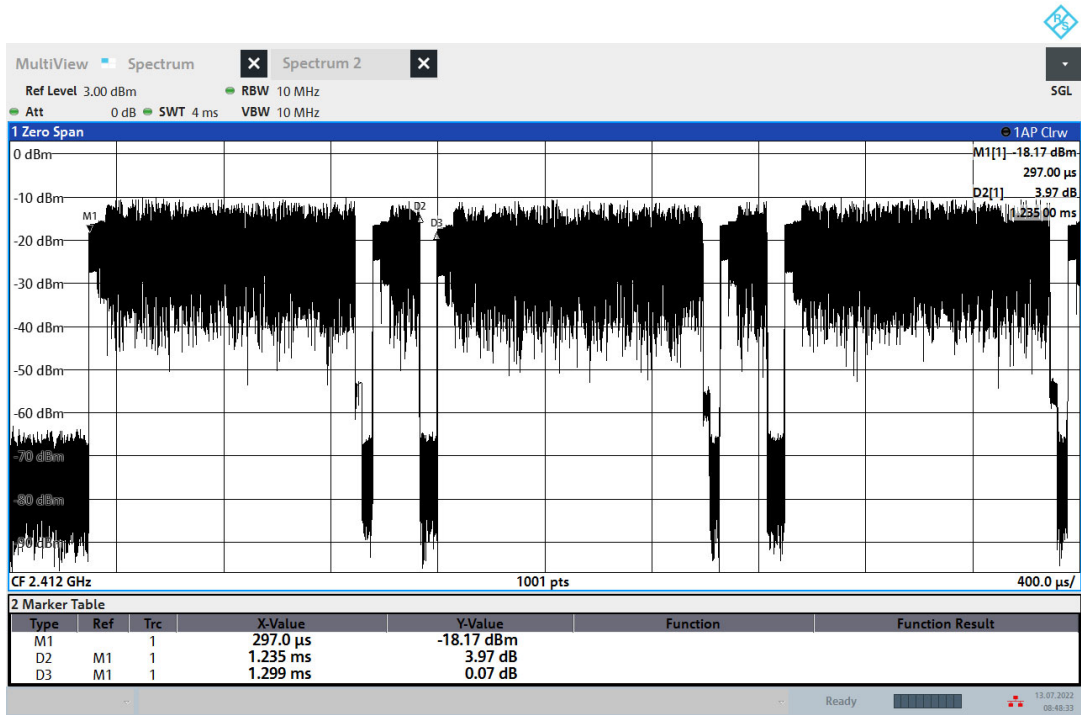

08:48:33 13.07.2022

802.11g 10M

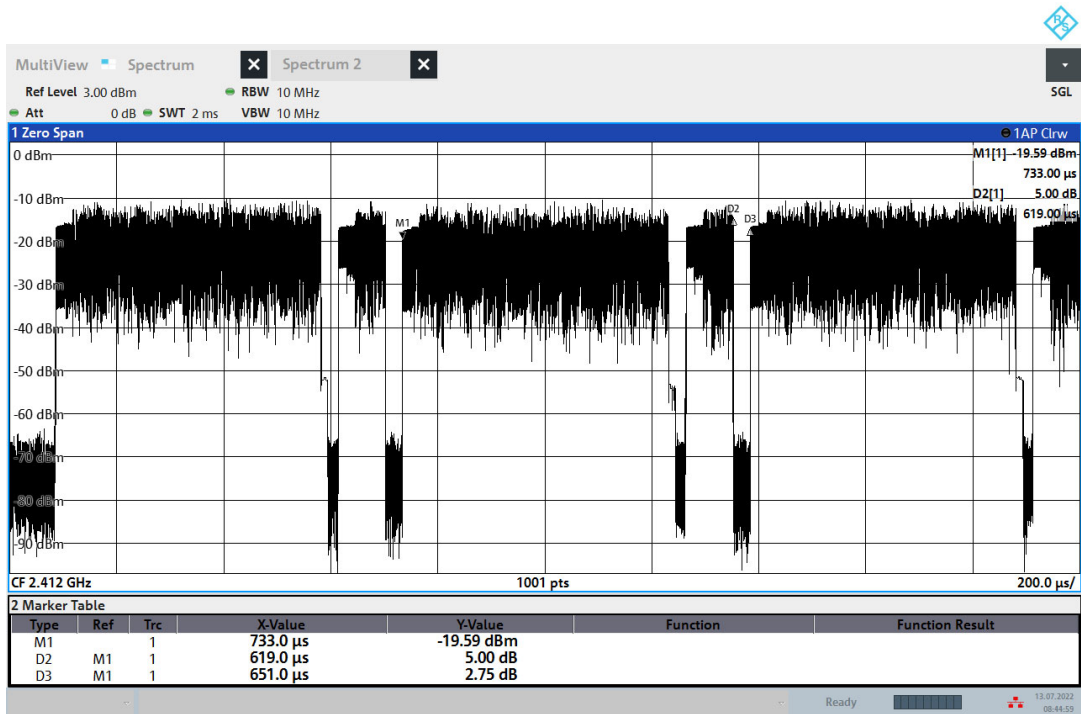

08:44:59 13.07.2022

802.11g 20M

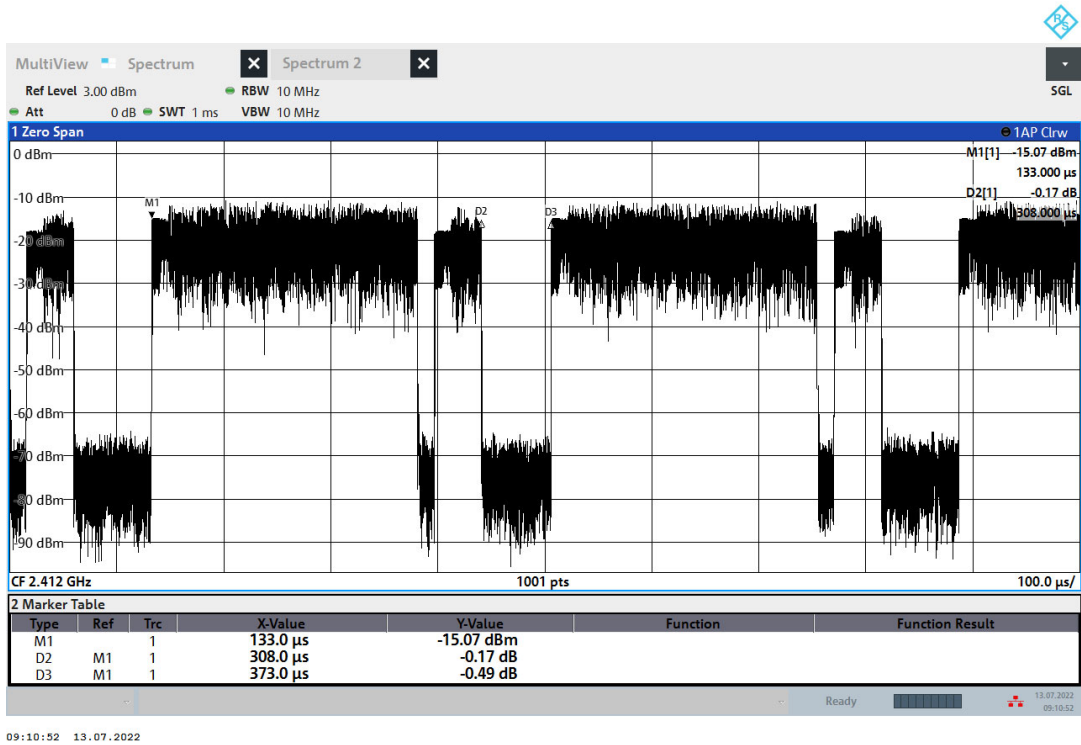

10. EMI Reduction Method During Compliance Testing

No modification was made during testing.