



Prüfbericht-Nr.: <i>Test Report No.:</i>	NN202S7E 001	Auftrags-Nr.: <i>Order No.:</i>	158219175	Seite 1 von 17 <i>Page 1 of 17</i>	
Kunden-Referenz-Nr.: <i>Client Reference No.:</i>	N/A	Auftragsdatum: <i>Order date:</i>	15.10.2020		
Auftraggeber: <i>Client:</i>	HID Global Corporation 611 Center Ridge Drive, Austin, TX 78753				
Prüfgegenstand: <i>Test item:</i>	BEEKS™ Combo Badge Beacon				
Bezeichnung / Typ-Nr.: <i>Identification / Type No.:</i>	BVCARD01				
Auftrags-Inhalt: <i>Order content:</i>	FCC and ISED Certification				
Prüfgrundlage: <i>Test specification:</i>	FCC Part 15 Subpart C, ANSI C63.10-2013 RSS-247 Issue 2, RSS-Gen Issue 5				
Wareneingangsdatum: <i>Date of receipt:</i>	14.08.2020				
Prüfmuster-Nr.: <i>Test sample No.:</i>	A002888609-001				
Prüfzeitraum: <i>Testing period:</i>	14.08.2020 - 20.10.2020				
Ort der Prüfung: <i>Place of testing:</i>	Hong Kong				
Prüflaboratorium: <i>Testing laboratory:</i>	TÜV Rheinland Hong Kong Ltd.				
Prüfergebnis*: <i>Test result*:</i>	Pass				
geprüft von / tested by:		kontrolliert von / reviewed by:			
					
Datum <i>Date</i>	Name / Stellung <i>Name / Position</i>	Unterschrift <i>Signature</i>	Datum <i>Date</i>	Name / Stellung <i>Name / Position</i>	Unterschrift <i>Signature</i>
23.11.2020	Benny Lau / Senior Project Manager		23.11.2020	Sharon Li / Senior Manager	
Sonstiges / Other:		FCC ID: SL6-BVCARD02 IC: 24824-BVCARD02			
Zustand des Prüfgegenstandes bei Anlieferung: <i>Condition of the test item at delivery:</i>		Prüfmuster vollständig und unbeschädigt <i>Test item complete and undamaged</i>			
* Legende:	1 = sehr gut P(ass) = entspricht o.g. Prüfgrundlage(n)	2 = gut F(ail) = entspricht nicht o.g. Prüfgrundlage(n)	3 = befriedigend N/A = nicht anwendbar	4 = ausreichend N/T = nicht getestet	5 = mangelhaft N/T = nicht getestet
Legend:	1 = very good P(ass) = passed a.m. test specification(s)	2 = good F(ail) = failed a.m. test specification(s)	3 = satisfactory N/A = not applicable	4 = sufficient N/T = not tested	5 = poor N/T = not tested
<p>Dieser Prüfbericht bezieht sich nur auf das o.g. Prüfmuster und darf ohne Genehmigung der Prüfstelle nicht auszugsweise vervielfältigt werden. Dieser Bericht berechtigt nicht zur Verwendung eines Prüfzeichens.</p> <p><i>This test report only relates to the a. m. test sample. Without permission of the test center this test report is not permitted to be duplicated in extracts. This test report does not entitle to carry any test mark.</i></p>					

Table of Content

	Page
Cover Page	1
Table of Content	2
Product information	4
Manufacturers declarations	4
Product function and intended use	4
Submitted documents.....	4
Independent Operation Modes	4
Related Submittal(s) Grants	4
Remark	4
Test Set-up and Operation Mode	5
Principle of Configuration Selection	5
Test Operation and Test Software	5
Special Accessories and Auxiliary Equipment	5
Countermeasures to achieve EMC Compliance	5
Test Methodology	6
Radiated Emission	6
Field Strength Calculation.....	6
Test Setup Diagram	7
Test Facility	9
Test Laboratory Information	9
List of Test and Measurement Instruments	10
Measurement Uncertainty	11
Results FCC Part 15 – Subpart C / RSS-247 Issue 2	12
FCC 15.203 – Antenna Requirement 1	Pass..... 12
FCC 15.204 – Antenna Requirement 2	Pass..... 12
RSS-Gen 6.3 – External Control.....	Pass..... 12
RSS-Gen 8.3 – Antenna Requirement	Pass..... 12
FCC 15.207/ RSS-Gen 8.8 – Conducted Emission on AC Mains	N/A..... 13
FCC 15.247 (a)(2) / RSS-247 5.2 – 6dB Bandwidth Measurement.....	Pass..... 13
RSS-Gen 6.6 – Occupied Bandwidth.....	Pass..... 13
FCC 15.247(b)(3) / RSS-247 5.4 – Maximum Peak Conducted Output Power	Pass..... 14

FCC 15.247(e) / RSS-247 5.2 – Power Spectral Density Pass..... 14

FCC 15.247(d) / RSS-247 5.5 – Spurious Conducted Emissions Pass..... 15

FCC 15.205/ RSS-Gen 8.9 – Radiated Emissions in Restricted Frequency Bands Pass..... 16

Appendix 1 – Test protocols 17 pages

Appendix 2 – Test setup 2 pages

Appendix 3 – EUT External Photos 2 pages

Appendix 4 – EUT Internal Photos 2 pages

Appendix 5 – RF exposure information 2 pages

Product information

Manufacturers declarations

	Transceiver
Operating frequency range	2402 - 2480 MHz
Type of modulation	GFSK
Number of channels	40
Channel separation	2 MHz
Type of antenna	Integral PCB Antenna
Antenna gain (dBi)	0 dBi
Power level	fix
Type of equipment	stand alone radio device
Connection to public utility power line	No
Nominal voltage	3.0VDC
Independent Operation Modes	Transmitting

Product function and intended use

The equipment under test (EUT) is a Bluetooth Low Energy Beacon card.

FCC ID: SL6-BVCARD02/ IC: 24824-BVCARD02

Models	Product description
BVCARD01	BEEKS™ Combo Badge Beacon

Submitted documents

Circuit Diagram
Block Diagram
Technical Description
User manual
Label

Independent Operation Modes

The basic operation modes are:

- Transmitting mode.

For further information refer to User Manual

Related Submittal(s) Grants

- This is a single application for certification of the Bluetooth Transmitter.

Remark

The test results in this test report are only relevant to the tested sample and does not involve any assessment in the production.

Test Set-up and Operation Mode

Principle of Configuration Selection

Emission: The equipment under test (EUT) was configured to measure its highest possible radiation level. The test modes were adapted accordingly in reference to the instructions for use.

Test Operation and Test Software

Test operation should refer to test methodology.

- A test mode sample is provided by the applicant to control the operating channel. The RF output power is fixed in the test mode sample. The setting of the RF output power used in the testing shall be fixed on the firmware of the final end product.

Special Accessories and Auxiliary Equipment

- None

Countermeasures to achieve EMC Compliance

- None

Test Methodology

Radiated Emission

The radiated emission measurements of the transmitter part were performed according to the procedures in ANSI C63.10-2013.

For measurement below 1GHz - the equipment under test (EUT) was placed at the middle of the 80 cm height turntable. For measurement above 1GHz - the EUT was placed at the middle of the 1.5 m height turntable and RF absorbing material was placed on ground plane between turntable and measuring antenna. During the testing, the EUT was operated standalone and arranged for maximum emissions. The EUT was tested in three orthogonal planes.

The investigation is performed with the EUT rotated 360°, the antenna height scanned between 1m/s and 4m, and the antenna rotated to repeat the measurements for both the horizontal and vertical antenna polarizations. Repeat the measurement steps until the maximum emissions were obtained.

All radiated tests were performed at an antenna to EUT with 3 meters distance, unless stated otherwise in particular parts of this test report.

Field Strength Calculation

The field strength at 3 m was established by adding the meter reading of the spectrum analyzer to the factors associated with antenna correction factor, cable loss, preamplifiers and filter attenuation.

The equation is expressed as follow:

$$FS = R + AF + CF + FA - PA$$

Where FS = Field Strength in dBuV/m at 3 meters.
R = Reading of Spectrum Analyzer in dBuV.
AF = Antenna Factor in dB.
CF = Cable Attenuation Factor in dB.
FA = Filter Attenuation Factor in dB.
PA = Preamplifier Factor in dB.

FA and PA are only be used for the measuring frequency above 1 GHz.

Test Setup Diagram

Diagram of Measurement Configuration for Radiation Test

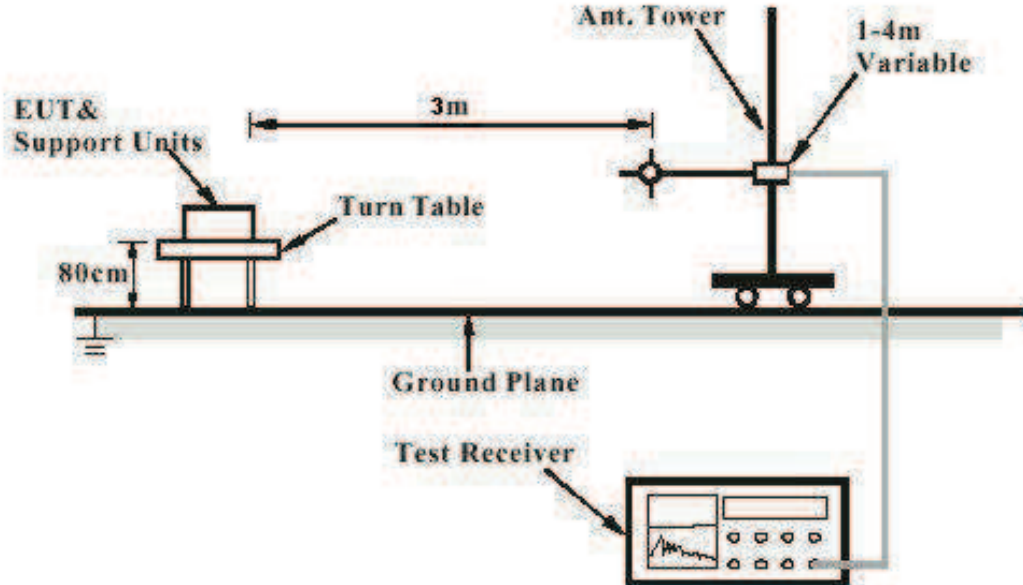

Note: Measurements above 1 GHz are done with a table height of 1.5m. In addition, there is RF absorbing material on the floor of the test site for above 1GHz measurement.

Diagram of Measurement Equipment Configuration for Mains Conduction Measurement (if applicable)

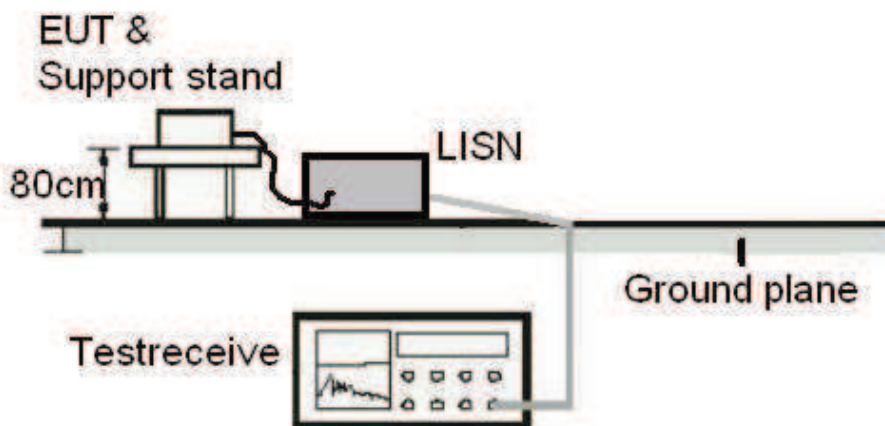
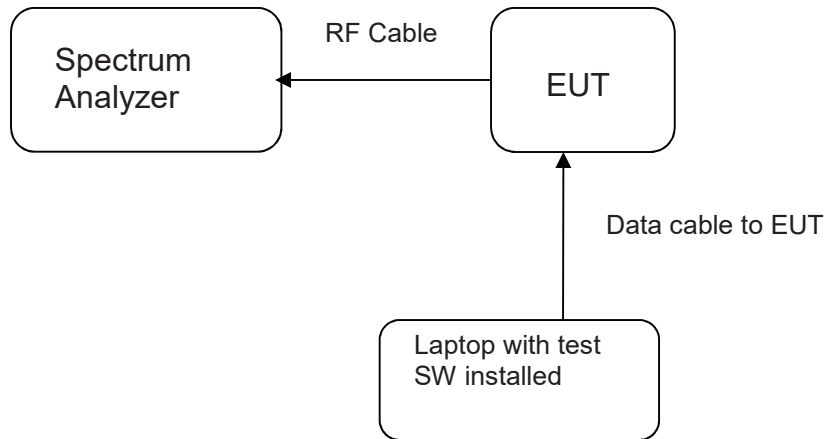

Diagram of Equipment Configuration for Antenna-port Conducted Measurement (if applicable)



Test Facility

Test Laboratory Information

TÜV Rheinland Hong Kong Ltd.

Address: 3-4, 11/F., Fou Wah Industrial Building, 10-16 Pun Shan Street, Tsuen Wan, N.T., Hong Kong

Tel.: +852 2192 1000

Fax: +852 2192 1001

Email service-gc@tuv.com

Web: www.tuv.com

The test facility is recognized or accredited by the following organizations:

FCC

Type	: Accredited Test Firm
Designation Number	: HK0013
Test Firm Registration Number	: 371735
Scope	: Intentional Radiators

Industry Canada

Type	: Accredited Test Firm
CAB identifier	: HK0013
ISED number	: 26152
Scope	: RSS-Gen, RSS-210, RSS-247

List of Test and Measurement Instruments

Radiated Emission

Equipment	Manufacturer	Type	Cal. Date	Due Date
Semi-anechoic Chamber (SiteVSWR)	Frankonia	Nil	16-May-20	16-May-21
Standard Gain Horn	ETS-Lindgren	3160-07	4-Sep-19	4-Sep-21
Standard Gain Horn	ETS-Lindgren	3160-08	26-Sep-19	26-Sep-21
Standard Gain Horn	ETS-Lindgren	3160-10	3-Oct-19	3-Oct-21
Double-Ridged Waveguide Horn	EMCO	3116	5-Oct-19	5-Oct-21
Double-Ridged Waveguide Horn	EMCO	3117	30-Aug-19	30-Aug-21
Test Receiver	R & S	ESU40	10-Oct-20	10-Oct-21
Coaxial cable	Huber+Suhner	CNM-NMCMILX800-473	4-Oct-19	4-Oct-21
Microwave Preamplifier	COM-POWER Corporation	PAM-118A	6-Mar-20	6-Mar-21
Preamplifier 18GHz to 40GHz with cable	A.H. Systems, Inc.	PAM-1840VH	30-Jan-20	30-Jan-21
High Pass Filter (cutoff freq. =1000MHz)	Trilithic	23042	30-Oct-19	30-Oct-21
High Frequency Cable	Pasternack	PE3VNA4001-3M	29-Jan-19	29-Jan-21

Radio Test

Equipment	Manufacturer	Type	Cal. Date	Due Date
Spectrum Analyzer	R & S	FSP40	17-Jan-20	17-Jan-21

Measurement Uncertainty

The estimated combined standard uncertainty for power-line conducted emissions measurements is ± 2.42 dB.

The estimated combined standard uncertainty for radiated emissions measurements is ± 4.81 dB (9kHz to 30MHz) and ± 4.62 dB (30MHz to 200MHz) and ± 5.67 dB (200MHz to 1000MHz) and is ± 5.07 dB (1GHz to 8.2GHz) and ± 4.58 dB (8.2GHz to 12.4GHz) and ± 4.78 dB (12.4GHz to 18GHz)

The estimated combined standard uncertainty for antenna conducted emission is ± 2.1 dB

The reported expanded uncertainty of measurement is stated as the standard uncertainty of measurement multiplied by the coverage factor of $k=2$, which for the level of confidence is approximately 95%.

Results FCC Part 15 – Subpart C / RSS-247 Issue 2

FCC 15.203 – Antenna Requirement 1		Pass
FCC Requirement:	No antenna other than that furnished by the responsible party shall be used with the device	
Results:	a) Antenna type:	Integral PCB antenna
	b) Manufacturer and model no:	N/A
	c) Peak Gain:	0 dBi
Verdict:	Pass	

FCC 15.204 – Antenna Requirement 2		Pass
FCC Requirement:	An intentional radiator may be operated only with the antenna with which it is authorized. If an antenna is marketed with the intentional radiator, it shall be of a type which is authorized with the intentional radiator.	
Results:	Only one integral antenna can be used.	
Verdict:	N/A	

RSS-Gen 6.3 – External Control		Pass
IC Requirement:	The device shall not have any external controls accessible to the user that enable it to be adjusted, selected or programmed to operate in violation of the limits prescribed in the applicable RSS.	
Results:	The device does not have any transmitter external controls accessible to the user that can be adjusted and operated in violation of the limits of this standard.	
Verdict:	Pass	

RSS-Gen 8.3 – Antenna Requirement		Pass
IC Requirement:	When a measurement at the antenna connector is used to determine RF output power, the effective gain of the device’s antenna shall be stated, based on measurement or on data from the antenna manufacturer.	
Results:	a) Antenna type:	Fixed Integral PCB antenna
	b) Manufacturer	N/A
	c) model no	N/A
	d) Gain with reference to an isotropic radiator:	0 dBi
Verdict:	Pass	

FCC 15.207/ RSS-Gen 8.8 – Conducted Emission on AC Mains	N/A
There is no AC power input or output ports on the EUT.	

FCC 15.247 (a)(2) / RSS-247 5.2 – 6dB Bandwidth Measurement	Pass
FCC/ IC Requirement: Systems using digital modulation techniques may operate in the 902 – 928 MHz, 2400 – 2483.5 MHz, and 5725 – 5850 MHz bands. The minimum 6dB bandwidth shall be at least 500kHz.	

Test Specification : ANSI C63.10 – 2013
 Test date : 20.10.2020
 Mode of operation : Tx mode
 Supply voltage : 3VDC
 Temperature : 25°C
 Humidity : 56%

Results: For test protocols please refer to Appendix 1

Channel frequency (MHz)	6 dB left (MHz)	6 dB right (MHz)	6dB bandwidth (kHz)	Limit (kHz)
2402	2404.590	2402.280	690	500
2440	2439.690	2440.380	690	500
2480	2479.690	2480.380	690	500

RSS-Gen 6.6 – Occupied Bandwidth	Pass
---	-------------

FCC/ IC Requirement: N/A

Test Specification : RSS-Gen
 Test date : 20.10.2020
 Mode of operation : Tx mode
 Supply voltage : 3VDC
 Temperature : 25°C
 Humidity : 56%

Results: Pre-scan has been conducted to determine the worst-case mode from all possible combinations between available modulations and packet types.

For test protocols refer to Appendix 1.

Frequency (MHz)	Left (MHz)	Right (MHz)	99% bandwidth (MHz)
2402	2401.550	2402.570	1.02
2440	2439.550	2440.570	1.02
2480	2479.540	2480.570	1.03

FCC 15.247(b)(3) / RSS-247 5.4 – Maximum Peak Conducted Output Power				Pass
FCC/ IC Requirement: For systems using digital modulation in the 902-928 MHz, 2400-2483.5 MHz, and 5725-5850MHz bands: 1 Watt (30dBm)				
Test Specification : ANSI C63.10 – 2013 Test date : 20.10.2020 Mode of operation : Tx mode Supply voltage : 3VDC Temperature : 25°C Humidity : 56%				
Results: For test protocols please refer to Appendix 1				
Frequency (MHz)	Cable loss (dB)	Measured Output Power (dBm)	Limit (dBm)	Verdict
2402	1.0	-0.53	30.0	Pass
2440	1.0	-1.45	30.0	Pass
2480	1.0	-2.47	30.0	Pass

FCC 15.247(e) / RSS-247 5.2 – Power Spectral Density				Pass
FCC/ IC Requirement: For digitally modulated systems, the power spectral density conducted from the intentional radiator to the antenna shall not be greater than 8 dBm in any 3 kHz band during any time interval of continuous transmission.				
Test Specification : ANSI C63.10 – 2013 Test date : 20.10.2020 Mode of operation : Tx mode Supply voltage : 3VDC Temperature : 25°C Humidity : 56%				
Results: For test protocols please refer to Appendix 1.				
Frequency (MHz)	Cable loss (dB)	Power density (dBm)	Limit (dBm)	Verdict
2402	1.0	-1.04	8.0	Pass
2440	1.0	-2.02	8.0	Pass
2480	1.0	-3.08	8.0	Pass

FCC 15.247(d) / RSS-247 5.5 – Spurious Conducted Emissions					Pass
Test Specification : ANSI C63.10 – 2013 Test date : 20.10.2020 Mode of operation : Tx mode Supply voltage : 3VDC Temperature : 25°C Humidity : 56%					
FCC/ IC Requirement: In any 100 kHz bandwidth outside the frequency band in which the spread spectrum or digitally modulated intentional radiator is operating, the radio frequency power that is produced by the intentional radiator shall be at least 20 dB below that in the 100 kHz bandwidth within the band that contains the highest level of the desired power, based on either an RF conducted or a radiated measurement.					
Results: Pre-scan has been conducted to determine the worst-case mode from all possible combinations between available modulations and data rate. Only the worst cases is shown below. For test protocols refer to Appendix 1					
Operating frequency (MHz)	Spurious frequency (MHz)	Spurious Level (dBm)	Reference value (dBm)	Delta (dB)	Verdict
2402	2400.000	-39.05	-2.04	37.01	Pass
2440	24616.000	-32.55	-3.02	29.53	Pass
2480	2483.500	-46.21	-4.08	42.13	Pass

FCC 15.205/ RSS-Gen 8.9 – Radiated Emissions in Restricted Frequency Bands		Pass
Test Specification : ANSI C63.10 – 2013 Test date : 26.10.2020 Mode of operation : Tx mode Frequency range : 9kHz – 25GHz Supply voltage : 3VDC Temperature : 23°C Humidity : 55%		
FCC/ IC Requirement: In any 100kHz bandwidth outside the frequency band at least 20dB below the highest level of the desired power. In addition, radiated emissions which fall in the restricted bands must also comply with the radiated emission general limits.		
Results: Pre-scan has been conducted to determine the worst-case mode from all possible combinations between available modulations and data rate. All three transmit frequency modes comply with the field strength within the restricted bands. There is no spurious found below 30MHz.		
Mode: 2402 MHz TX		Vertical Polarization
Freq MHz	Level dBuV/m	Limit/ Detector dBuV/m
2390.000	40.4	74.0 / PK
2390.000	22.3	54.0 / AV
7205.443	43.9	74.0 / PK
7205.443	31.3	54.0 / AV
Mode: 2402 MHz TX		Horizontal Polarization
Freq MHz	Level dBuV/m	Limit/ Detector dBuV/m
2390.000	54.1	74.0 / PK
2390.000	41.1	54.0 / AV
7205.439	51.7	74.0 / PK
7205.439	41.1	54.0 / AV
Mode: 2440 MHz TX		Vertical Polarization
Freq MHz	Level dBuV/m	Limit/ Detector dBuV/m
4880.000	47.0	74.0 / PK
4880.000	40.1	54.0 / AV
Mode: 2440 MHz TX		Horizontal Polarization
Freq MHz	Level dBuV/m	Limit/ Detector dBuV/m
4880.000	47.5	74.0 / PK
4880.000	43.1	54.0 / AV
Mode: 2480 MHz TX		Vertical Polarization
Freq MHz	Level dBuV/m	Limit/ Detector dBuV/m
2483.500	52.3	74.0 / PK
2483.500	23.4	54.0 / AV
4960.881	46.3	74.0 / PK
4960.881	34.9	54.0 / AV

Mode: 2480 MHz TX		Horizontal Polarization	
Freq MHz	Level dBuV/m	Limit/ Detector dBuV/m	
2483.500	64.8	74.0 / PK	
2483.500	29.9	54.0 / AV	
4960.572	47.5	74.0 / PK	
4960.572	35.6	54.0 / AV	

Appendix 1

Test Results

6 dB Bandwidth Measurement

TX frequency: 2402MHz

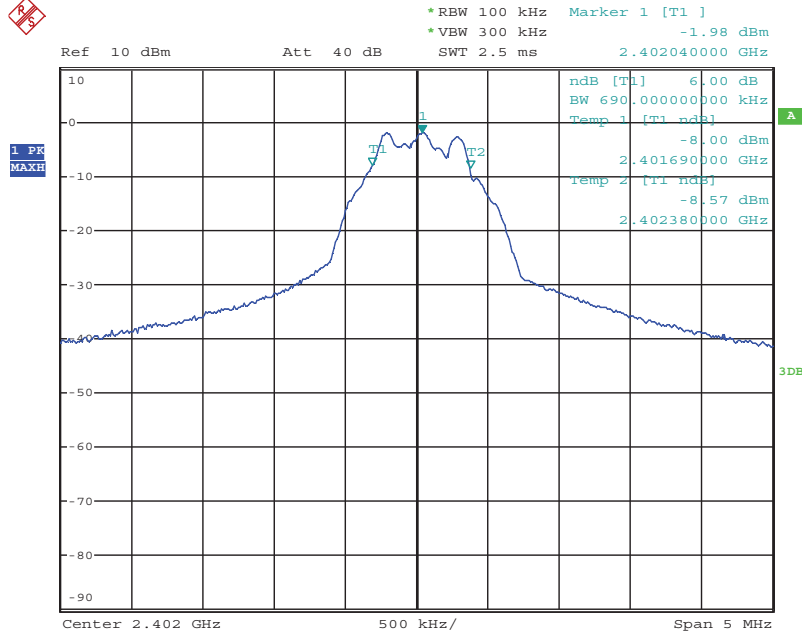

Date: 20.OCT.2020 08:01:35

TX frequency: 2440MHz

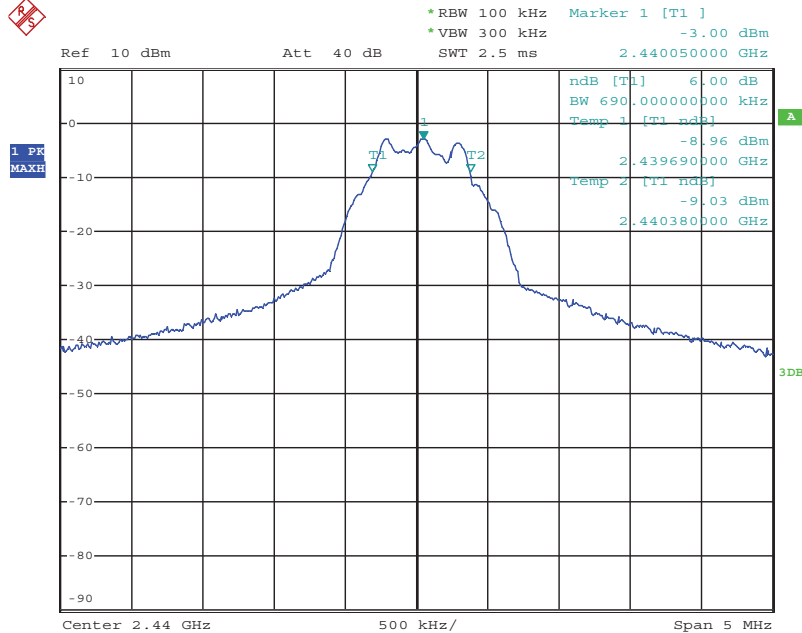

Date: 20.OCT.2020 08:02:31

TX frequency: 2480MHz

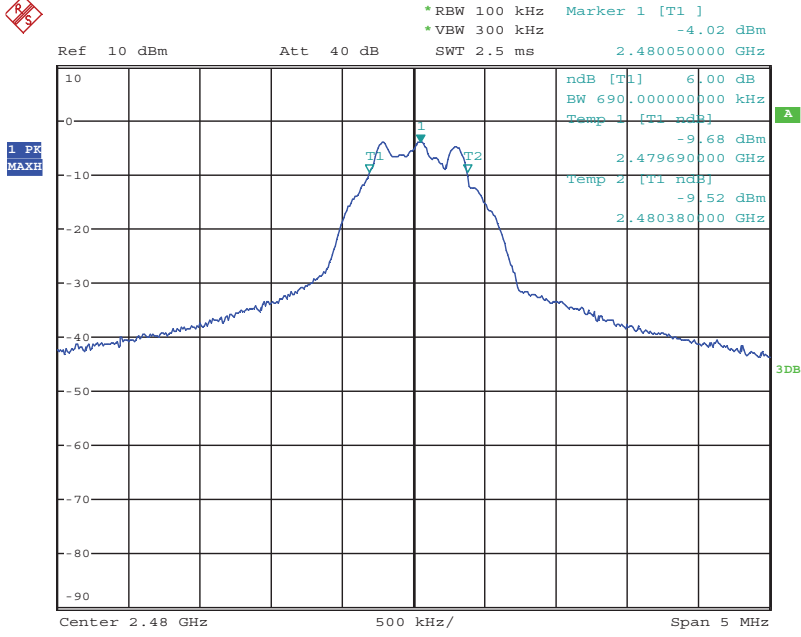

Date: 20.OCT.2020 08:03:14

Occupied Bandwidth Measurement

TX frequency: 2402MHz

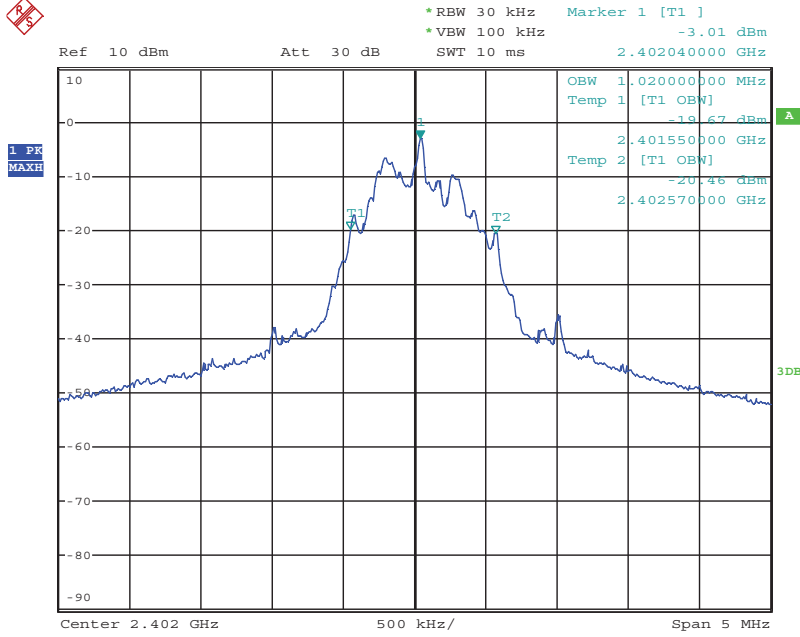

Date: 20.OCT.2020 08:30:08

TX frequency: 2440MHz

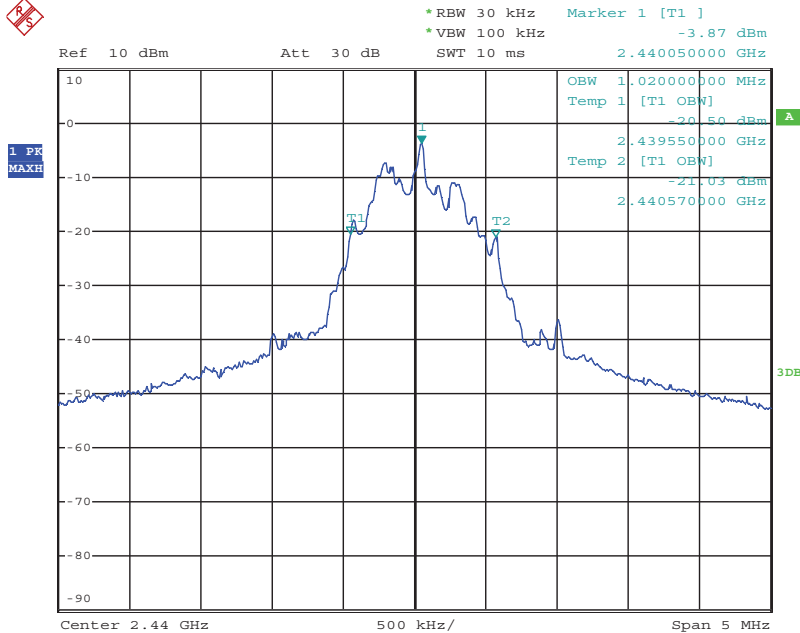

Date: 20.OCT.2020 08:29:23

TX frequency: 2480MHz

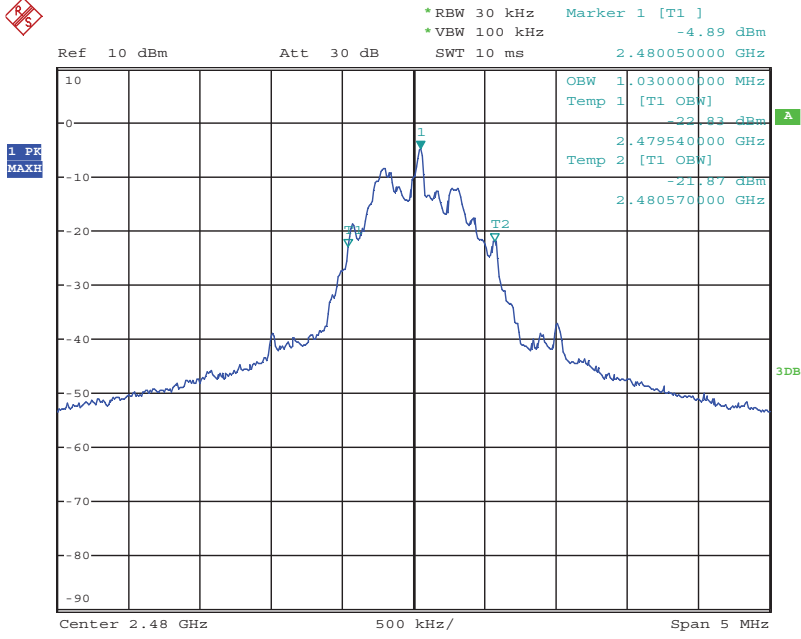

Date: 20.OCT.2020 08:30:47

Maximum Peak Conducted Output power

TX frequency: 2402MHz

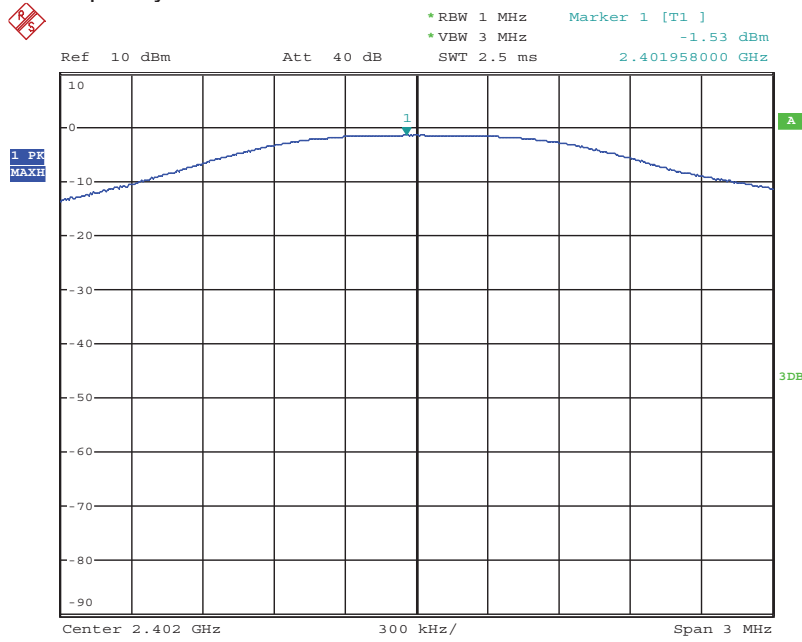

Date: 20.OCT.2020 08:05:43

TX frequency: 2440MHz

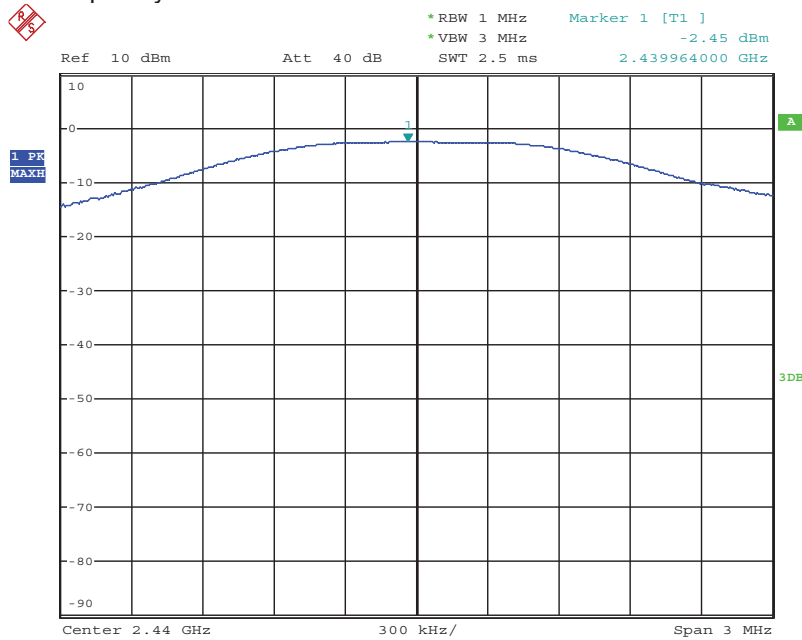

Date: 20.OCT.2020 08:05:11

TX frequency: 2480MHz

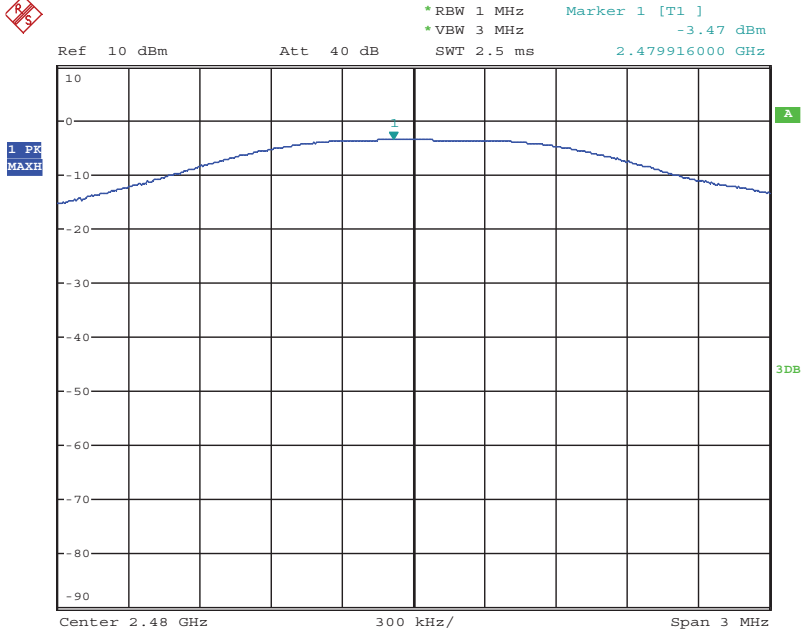

Date: 20.OCT.2020 08:04:32

Power Spectral Density

TX frequency: 2402MHz

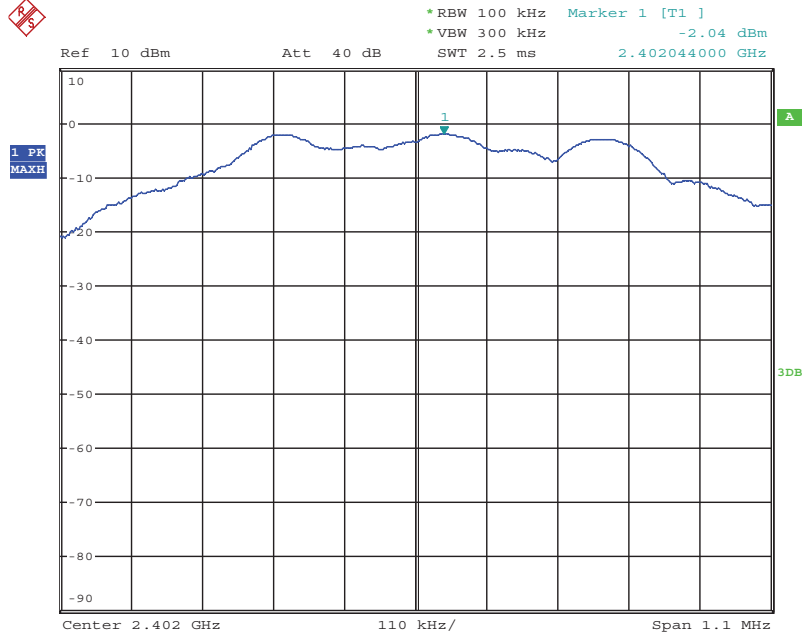

Date: 20.OCT.2020 08:06:36

TX frequency: 2440MHz

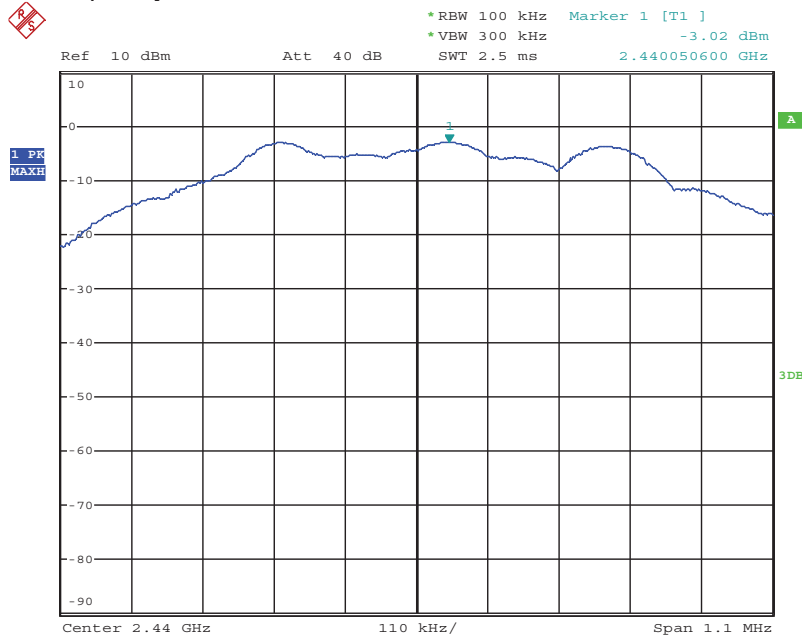

Date: 20.OCT.2020 08:07:08

TX frequency: 2480MHz

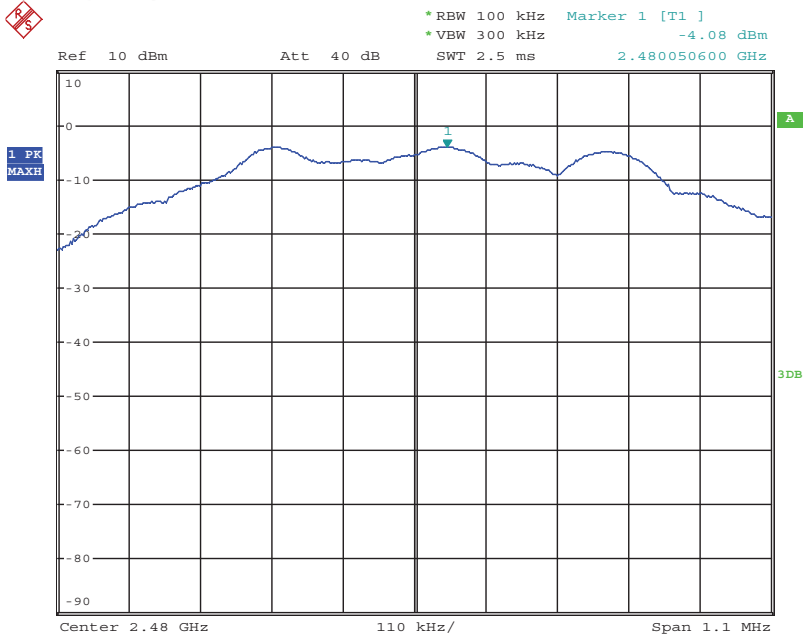

Date: 20.OCT.2020 08:07:46

Spurious Conducted Emissions

TX frequency: 2402MHz

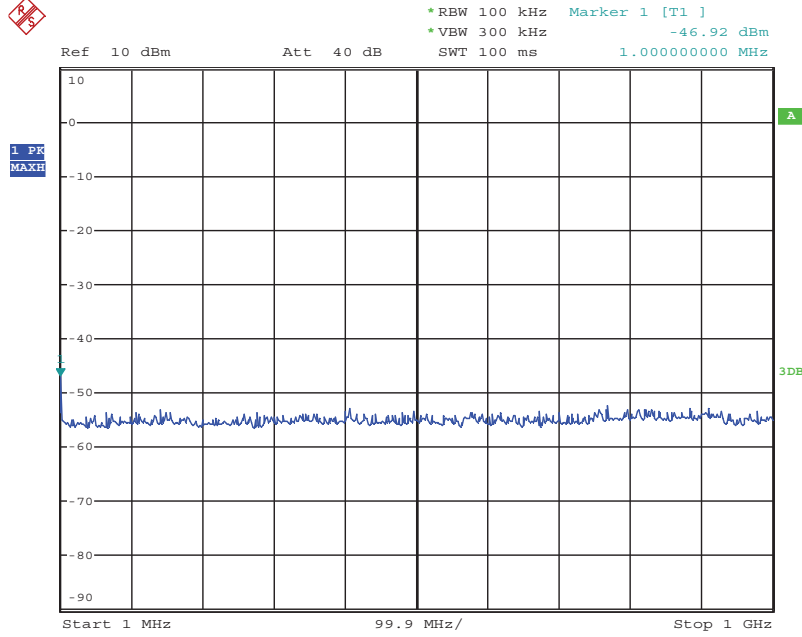

Date: 20.OCT.2020 08:12:56

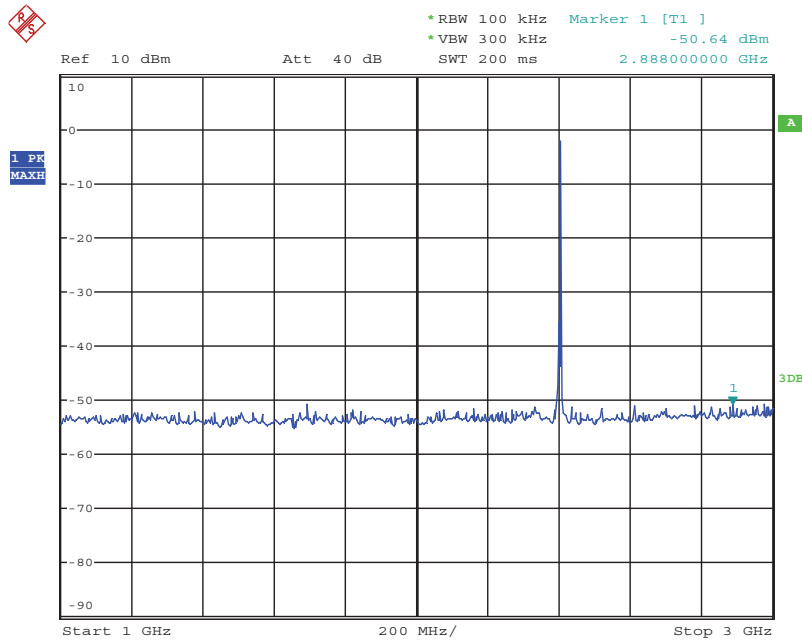

Date: 20.OCT.2020 08:13:28



*RBW 100 kHz Marker 1 [T1]
*VBW 300 kHz -42.61 dBm
Ref 10 dBm Att 40 dB SWT 1 s 7.440000000 GHz

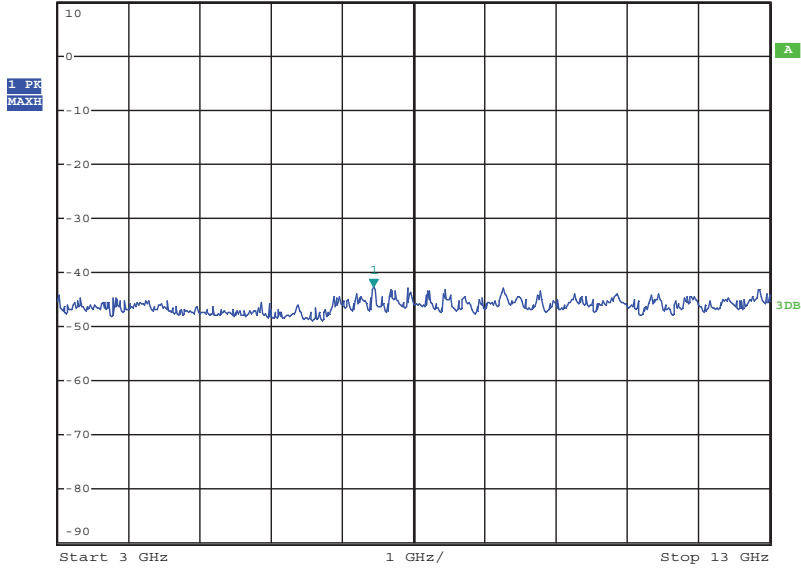

Date: 20.OCT.2020 08:13:58



*RBW 100 kHz Marker 1 [T1]
*VBW 300 kHz -31.94 dBm
Ref 10 dBm Att 40 dB SWT 1.2 s 23.032000000 GHz

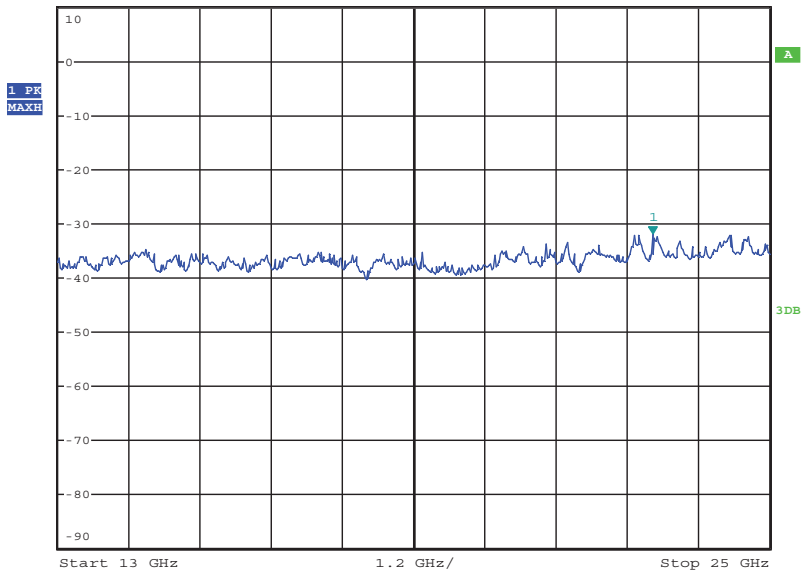

Date: 20.OCT.2020 08:11:18

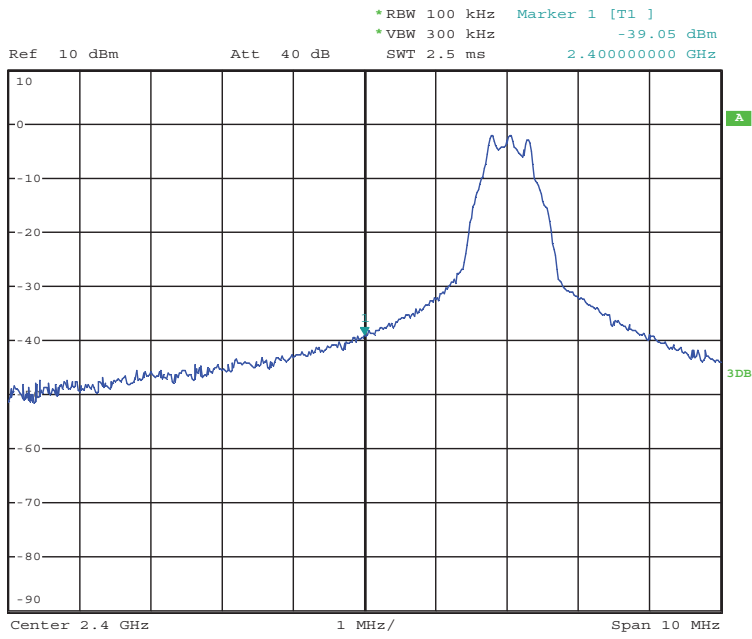

Date: 20.OCT.2020 08:12:25

TX frequency: 2440MHz

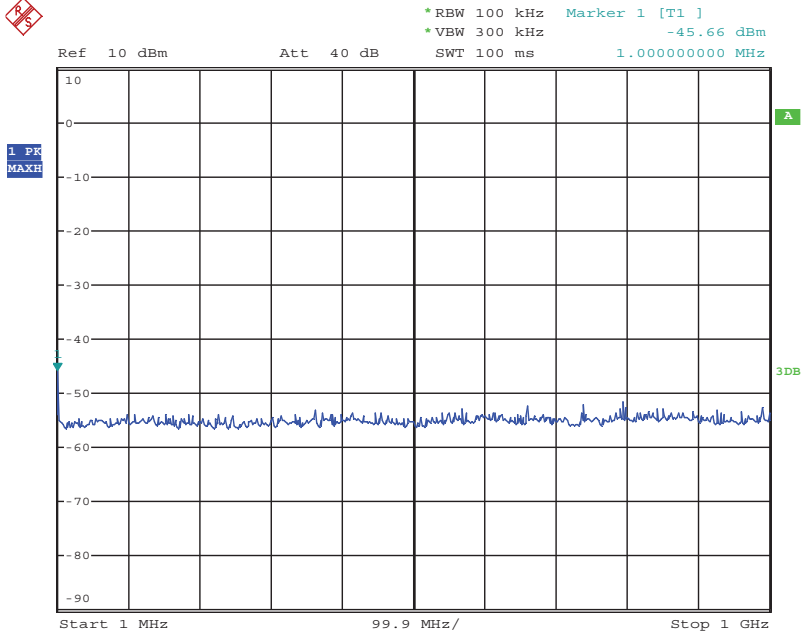

Date: 20.OCT.2020 08:15:06

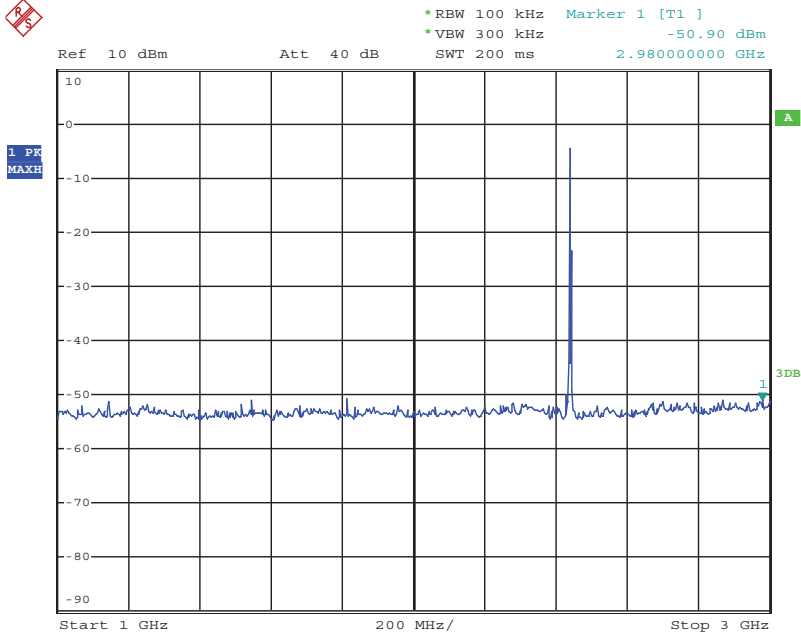

Date: 20.OCT.2020 08:15:42



*RBW 100 kHz Marker 1 [T1]
*VBW 300 kHz -42.63 dBm
Ref 10 dBm Att 40 dB SWT 1 s 9.280000000 GHz

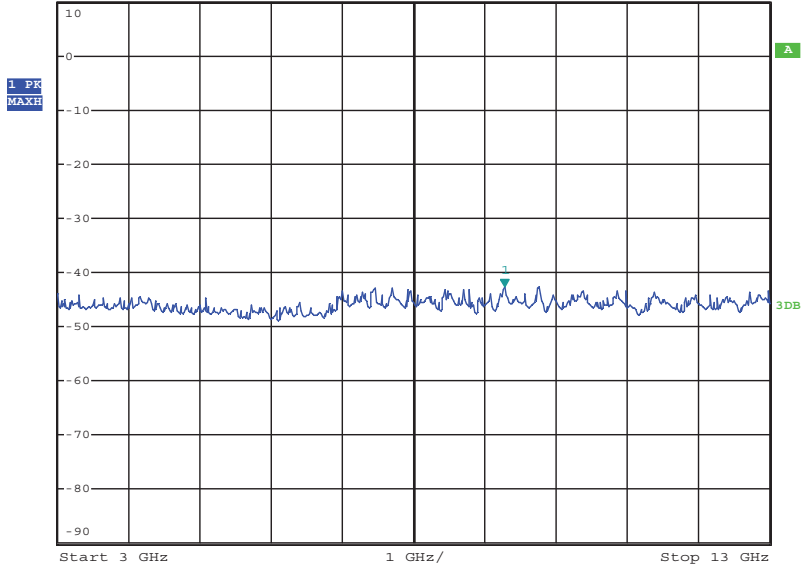

Date: 20.OCT.2020 08:14:37



*RBW 100 kHz Marker 1 [T1]
*VBW 300 kHz -32.55 dBm
Ref 10 dBm Att 40 dB SWT 1.2 s 24.616000000 GHz

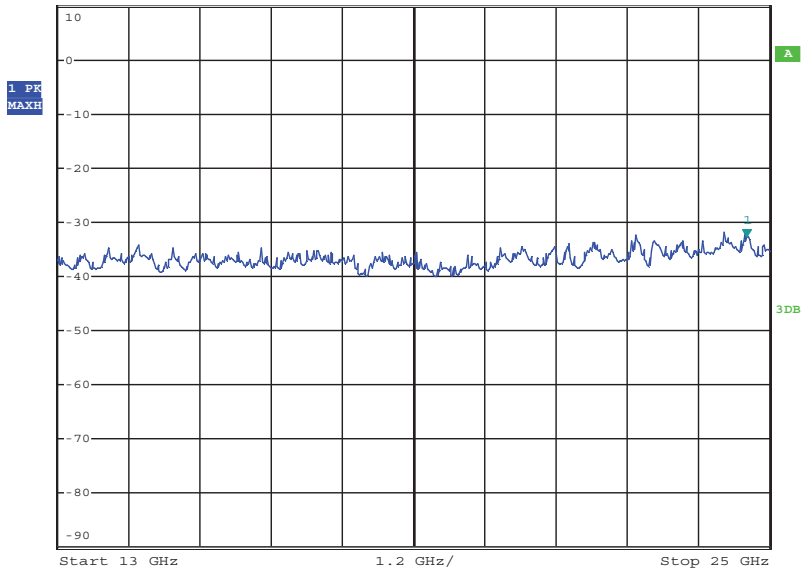

Date: 20.OCT.2020 08:16:09

TX frequency: 2480MHz

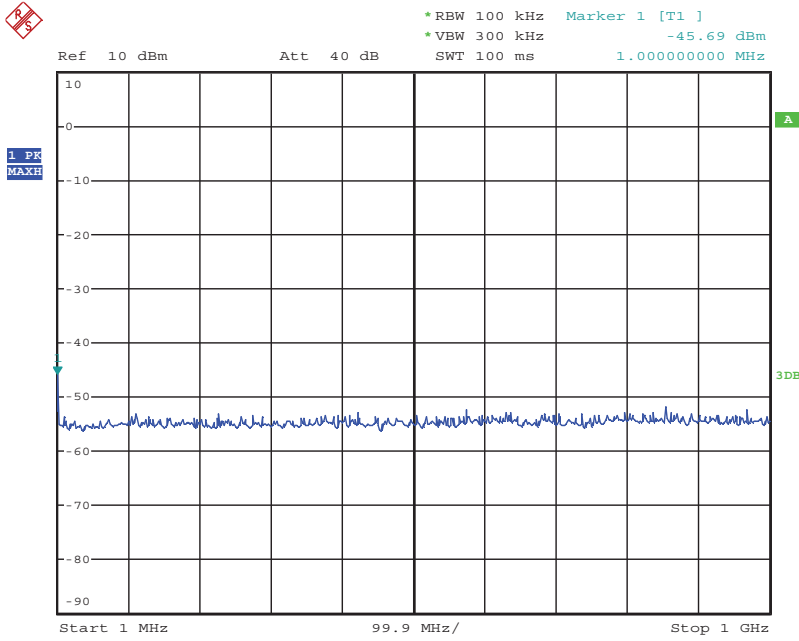

Date: 20.OCT.2020 08:09:28

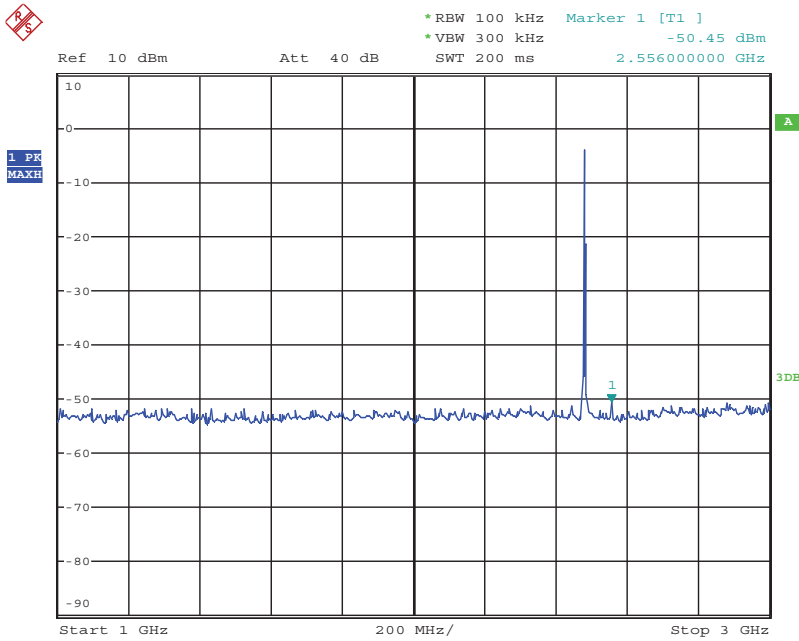

Date: 20.OCT.2020 08:10:17



*RBW 100 kHz Marker 1 [T1]
*VBW 300 kHz -41.87 dBm
Ref 10 dBm Att 40 dB SWT 1 s 9.780000000 GHz

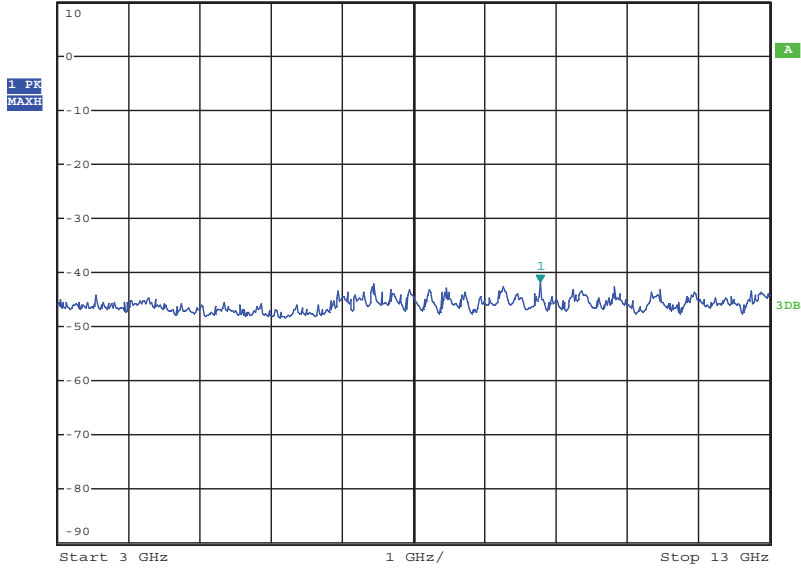

Date: 20.OCT.2020 08:10:49



*RBW 100 kHz Marker 1 [T1]
*VBW 300 kHz -31.94 dBm
Ref 10 dBm Att 40 dB SWT 1.2 s 23.032000000 GHz

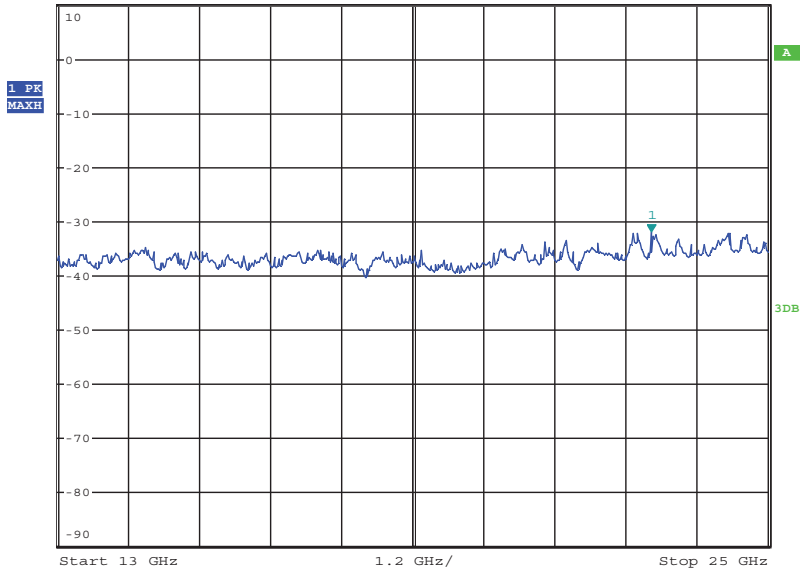

Date: 20.OCT.2020 08:11:18



Ref 10 dBm Att 40 dB RBW 100 kHz Marker 1 [T1]
VBW 300 kHz -46.21 dBm
SWT 2.5 ms 2.483530000 GHz

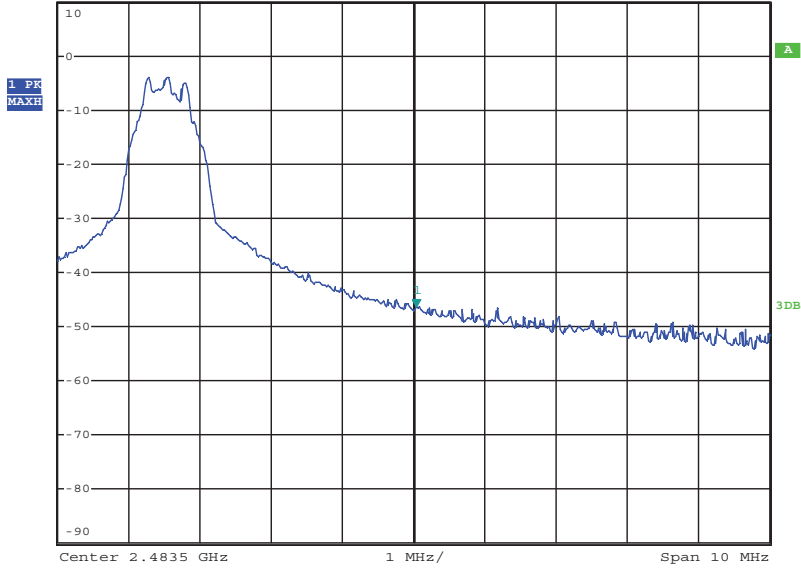

Date: 20.OCT.2020 08:08:51