



## **Certification Test Report**

**FCC ID: SK9SNIC1  
IC: 864G-SNIC1**

**FCC Rule Part: 1.1310  
ISED Canada Radio Standards Specification: RSS-102**

**Report Number: AT72133597-4P0**

**Manufacturer: Itron, Inc.  
Model: SNIC1**

**Test Begin Date: December 19, 2017  
Test End Date: December 19, 2017**

**Report Issue Date: February 23, 2018**



FOR THE SCOPE OF ACCREDITATION UNDER Certificate Number: AT-2021

This report must not be used by the client to claim product certification, approval, or endorsement by ANAB, NIST, or any agency of the Federal Government.

**Prepared by:**

A handwritten signature in black ink, appearing to read 'R McGann'.

**Ryan McGann  
Senior Engineer  
TÜV SÜD America Inc.**

**Reviewed by:**

A handwritten signature in black ink, appearing to read 'Steve O'Steen'.

**Steve O'Steen  
Service Line Manager, EMC  
TÜV SÜD America Inc.**

This test report shall not be reproduced except in full. This report may be reproduced in part with prior written consent of TÜV SÜD America Inc. The results contained in this report are representative of the sample(s) submitted for evaluation.

**This report contains 11 pages**

# TABLE OF CONTENTS

<b>1</b>	<b>GENERAL .....</b>	<b>3</b>
1.1	PURPOSE.....	3
1.2	MANUFACTURER INFORMATION.....	3
1.3	PRODUCT DESCRIPTION.....	3
1.4	TEST METHODOLOGY AND CONSIDERATIONS .....	4
<b>2</b>	<b>TEST FACILITIES.....</b>	<b>5</b>
2.1	LOCATION .....	5
2.2	LABORATORY ACCREDITATIONS/RECOGNITIONS/CERTIFICATIONS .....	5
2.3	RADIATED EMISSIONS TEST SITE DESCRIPTION .....	6
2.3.1	<i>Semi-Anechoic Chamber Test Site</i> .....	6
<b>3</b>	<b>APPLICABLE STANDARD REFERENCES.....</b>	<b>7</b>
<b>4</b>	<b>LIST OF TEST EQUIPMENT.....</b>	<b>7</b>
<b>5</b>	<b>SUPPORT EQUIPMENT.....</b>	<b>8</b>
<b>6</b>	<b>EQUIPMENT UNDER TEST SETUP BLOCK DIAGRAM .....</b>	<b>8</b>
<b>7</b>	<b>SUMMARY OF TESTS.....</b>	<b>9</b>
7.1	MAXIMUM PERMISSIBLE EXPOSURE – FCC: SECTION 1.1310; ISED CANADA: RSS-102 4.....	9
7.1.1	<i>Measurement Procedure</i> .....	9
7.1.2	<i>Measurement Results</i> .....	9
7.1.3	<i>Summation of MPE Ratios – Simultaneous Transmissions</i> .....	10
<b>8</b>	<b>ESTIMATION OF MEASUREMENT UNCERTAINTY .....</b>	<b>11</b>
<b>9</b>	<b>CONCLUSION.....</b>	<b>11</b>

## 1 GENERAL

### 1.1 Purpose

The purpose of this report is to demonstrate compliance with Part 1 Subpart I of the FCC's Code of Federal Regulations and Innovation, Science, and Economic Development Canada's Radio Standards Specification RSS-102 Certification for a Class II Permissive Change.

The purpose of this Class II Permissive Change is to add a new antenna and host combination.

### 1.2 Manufacturer Information

Itron, Inc.  
313 N Hwy 11  
West Union, SC 29696

### 1.3 Product Description

The Itron Smart Network Interface Card (model: SNIC1) module is built on Itron's IPv6 OpenWay platform, and includes the Adaptive Communications Technology (ACT). It can process, analyze, communicate and react in real-time. Adaptive communications enable devices to interact with each other while dynamically switching between Radio Frequency (RF) and Power Line Carrier (PLC) to ensure the fastest and most reliable communications path. The communication module utilizes 900 MHz radio frequency (RF), power line carrier (carrier current system) and 2.4 GHz Wi-Fi operation bands.

The purpose of this Class II Permissive Change is to add new antennas and host combination. For this Class II Permissive Change, the SNIC1 was integrated into the Itron, Inc. RN-ERT Gateway STAR (FCC ID: EO9ORRNA). The new 900MHz antenna is a PCTEL BOA9022NM-ITR used only with the RN-ERT Gateway STAR host. The 2.4 GHz antenna is an internal microstrip patch to the RN-ERT Gateway STAR host device.

This test report documents the compliance of the maximum permissible exposure for uncontrolled exposure of a fixed device.

#### 2.4GHz WiFi Technical Information:

Detail	Description
Frequency Range	2412 – 2462 MHz
Number of Channels	802.11b/g/n (HT 20): 11 802.11n (HT 40): 7
Modulation Format	802.11b: DSSS (DBPSK / DQPSK / CCK) 802.11g/n (HT 20/40): OFDM (BPSK / QPSK / 16QAM / 64QAM)
Data Rates	802.11b: 1 – 11 Mbps 802.11g: 6 – 54 Mbps 802.11n (HT 20): 6.5 – 72 Mbps 802.11n (HT 40): 13.5 – 150 Mbps
Number of Inputs/Outputs	1T1R
Operating Voltage	24 Vdc
Antenna Type / Gain	Micro Strip Patch Antenna / 3 dBi Micro Strip Patch Antenna / 2.15 dBi (new, in host)

## 900MHz FHSS Radio Technical Information:

Detail	Description
Frequency Range	902.2 – 927.8 MHz
Number of Channels	FSK 10kbps: 513 FSK 50kbps: 64 FSK 150kbps: 64 OFDM: 64 DSSS: 64
Modulation Format	FSK, OFDM, DSSS
Data Rates (kbps)	FSK: 10, 50, 150 OFDM: 200, 600 DSSS: 6.25, 12.5
Operating Voltage	24Vdc
Antenna Type(s) / Gain(s)	Micro Strip Patch Antenna / 2.5 dBi PCTEL BOA9022NM-ITR / 2.6 dBi (new)

## 900MHz Hybrid Radio Technical Information

Detail	Description
Frequency Range	902.8 – 926.8 MHz
Number of Channels	31
Modulation Format	OFDM
Data Rates	1200kbps
Operating Voltage	24Vdc
Antenna Type / Gain	Micro Strip Patch Antenna / 2.5 dBi PCTEL BOA9022NM-ITR / 2.6 dBi (new)

## 900MHz RN-ERT Gateway STAR Technical Information (FCC ID: EO9ORRN)

Detail	Description
Frequency Range	902 – 928 MHz ISM Band
Number of Channels	N/A
Modulation Format	N/A
Data Rates	N/A
Operating Voltage	120Vac / 60Hz
Antenna Type / Gain	Monopole (attached) / 5.15 dBi

Test Sample Serial Number: 630000C43E

Test Sample Condition: The test samples were provided in good working order with no visible defects.

#### 1.4 Test Methodology and Considerations

The data presented in this report represents the worst case where applicable. The worst-case data rate for the 2.4GHz WiFi radio was 802.11b mode at 5.5 MBPS. The worst-case data rate for the 900MHz radio was OFDM at 1200kbps. The EUT is not capable of operating in frequency hopping mode and the Hybrid mode simultaneously.

The maximum permissible exposure for the RN-ERT Gateway STAR was measured independent of the maximum permissible exposure of the SNIC1 evaluated in the host device. The measured maximum permissible exposure for the RN-ERT Gateway STAR is reported with the original certification of the RN-ERT Gateway STAR (FCC ID: EO9ORRNA). The worst case measured values of the host device were included in the summation of maximum permissible exposure ratios.

The EUT was evaluated for maximum permissible exposure in a typical host. The data presented in this report represents the worst-case mode of operation.

## **2 TEST FACILITIES**

### **2.1 Location**

The radiated and conducted emissions test sites are located at the following address:

TÜV SÜD America, Inc.  
5015 B.U. Bowman Drive  
Buford, GA 30518  
Phone: (770) 831-8048  
Fax: (770) 831-8598

### **2.2 Laboratory Accreditations/Recognitions/Certifications**

TÜV SÜD America, Inc. is accredited to ISO/IEC 17025 by the ANSI-ASQ National Accreditation Board/ANAB accreditation program, and has been issued certificate number AT-2021 in recognition of this accreditation. Unless otherwise specified, all tests methods described within this report are covered under the ISO/IEC 17025 scope of accreditation.

The Semi-Anechoic Chamber Test Site, Open Area Test Site (OATS) and Conducted Emissions Site have been fully described, submitted to, and accepted by the FCC, ISED Canada and the Japanese Voluntary Control Council for Interference by information technology equipment.

FCC Registration Number: 391271

ISED Canada Lab Code: IC 23597

VCCI Member Number: 1831

- VCCI OATS Registration Number R-1526
- VCCI Conducted Emissions Site Registration Number: C-1608

## 2.3 Radiated Emissions Test Site Description

### 2.3.1 Semi-Anechoic Chamber Test Site

The Semi-Anechoic Chamber Test Site consists of a 20' x 30' x 18' shielded enclosure. The chamber is lined with Toyo Ferrite Grid Absorber, model number FFG-1000. The ferrite tile grid is 101 x 101 x 19mm thick and weighs approximately 550 grams. These tiles are mounted on steel panels and installed directly on the inner walls of the chamber.

The turntable is 150cm in diameter and is located 160cm from the back wall of the chamber. The chamber is grounded via 1 - 8' copper ground rod, installed at the center of the back wall, it is bound to the ground plane using 3/4" stainless steel braided cable.

The turntable is all steel, flush mounted table installed in an all steel frame. The table is remotely operated from inside the control room located 25' from the range. The turntable is electrically bonded to the surrounding ground plane via steel fingers installed on the edge of the turn table. The steel fingers make constant contact with the ground plane during operation.

Behind the turntable is a 3' x 6' x 4' deep shielded pit used for support equipment if necessary. The pit is equipped with 1 - 4" PVC chases from the turntable to the pit that allow for cabling to the EUT if necessary. The underside of the turntable can be accessed from the pit so cables can be supplied to the EUT from the pit.

A diagram of the Semi-Anechoic Chamber Test Site is shown in Figure 2.3-1 below:

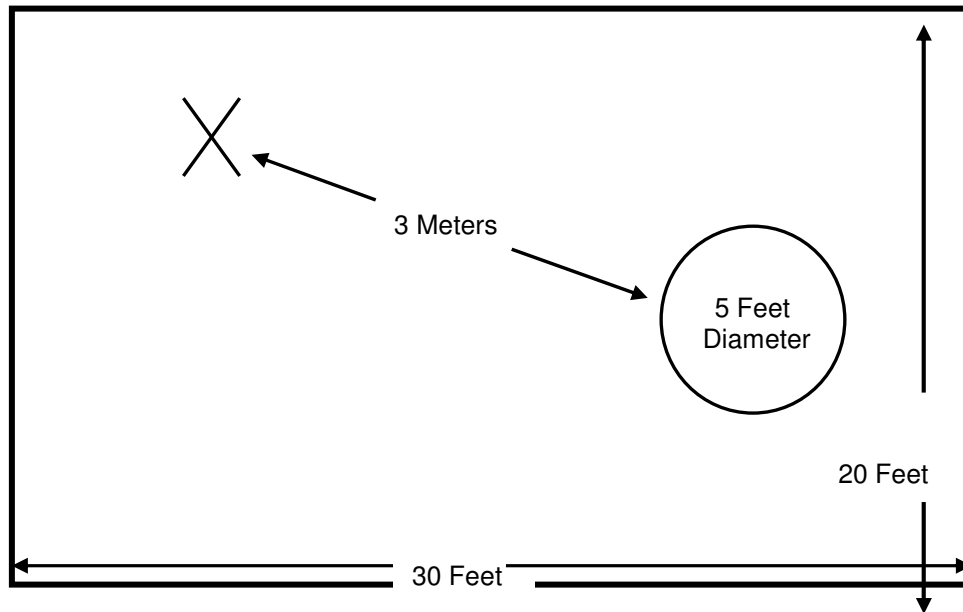

Figure 2.3-1: Semi-Anechoic Chamber Test Site

### 3 APPLICABLE STANDARD REFERENCES

The following standards were used:

- ❖ ANSI C63.4-2014: American National Standard for Methods of Measurement of Radio-Noise Emissions from Low-Voltage Electrical and Electronic Equipment in the Range of 9 kHz to 40 GHz.
- ❖ ANSI C63.10-2013: American National Standard of Procedures for Compliance Testing of Unlicensed Wireless Devices.
- ❖ IEEE C95.3-2002: IEEE Recommended Practice for Measurements and Computations of Radio Frequency Electromagnetic Fields with Respect to Human Exposure to Such Fields, 100 kHz to 300 GHz.
- ❖ US Code of Federal Regulations (CFR): Title 47, Part 1, Subpart I: Procedures Implementing the National Environmental Policy Act of 1969, 2017
- ❖ FCC KDB 447498 D01 General RF Exposure Guidance v06, Oct. 23, 2015.
- ❖ ISED Canada Radio Standards Specification: RSS-102 – Radio Frequency (RF) Exposure Compliance of Radiocommunications Apparatus (All Frequency Bands), Issue 5, March 2015.

### 4 LIST OF TEST EQUIPMENT

The calibration interval of test equipment is annually or the manufacturer's recommendations. Where the calibration interval deviates from the annual cycle based on the instrument manufacturer's recommendations, it shall be stated below.

**Table 4-1: Test Equipment**

AssetID	Manufacturer	Model #	Equipment Type	Serial #	Last Calibration Date	Calibration Due Date
RE137	ETS-Lindgren	HI-6005	Probes	23667	8/11/2017	8/11/2018

**NOTE: All test equipment was used only during active calibration cycles.**

## 5 SUPPORT EQUIPMENT

Table 5-1: Support Equipment

Item	Equipment Type	Manufacturer	Model/Part Number	Serial Number
1	Host Device	Itron, Inc.	RN-ERT Gateway STAR	320483111

Table 5-2: Cable Description

Cable	Cable Type	Length	Shield	Termination
A	AC Power Cable	1.75 m	No	Host Device to AC Mains
B	Ground Braid	1.75 m	No	Host Device – Reference Ground Plane

## 6 EQUIPMENT UNDER TEST SETUP BLOCK DIAGRAM

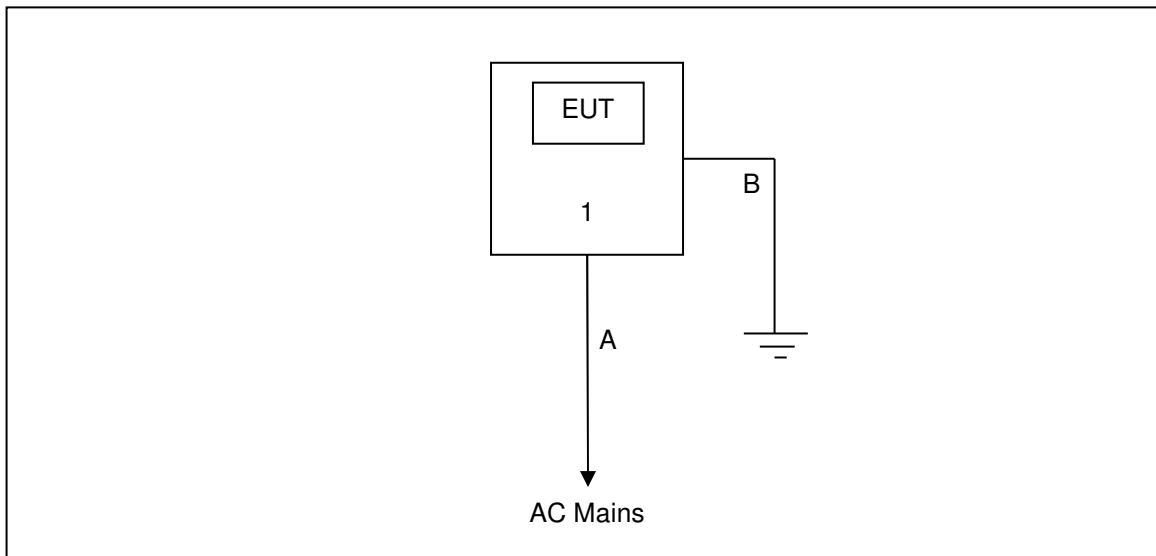

Figure 6-1: Test Setup Block Diagram



## 7 SUMMARY OF TESTS

Along with the tabular data shown below, plots were taken of all signals deemed important enough to document.

### 7.1 Maximum Permissible Exposure – FCC: Section 1.1310; ISED Canada: RSS-102 4

#### 7.1.1 Measurement Procedure

The EUT was placed on a non-conductive platform in the center of the turntable at a height of 1.5 meters above the ground plane. The measurement probe was located 20 centimeters away from the EUT on an adjustable antenna mast. The EUT was rotated through 360 degrees so that the maximum radiated emissions level would be detected. The mast was adjusted until the evaluated results are less than 10% of the applicable limit. Once a stable reading was obtained, the maximum was recorded. The azimuth and elevation leading to the direction of maximum exposure was identified. The evaluation points in the horizontal plane were along radials extending from the antenna axis 45 degrees apart starting from the direction of maximum exposure.

#### 7.1.2 Measurement Results

Performed by: Ryan McGann

**Table 7.1.2-1: Maximum Permissible Exposure – 900MHz Radio**

Frequency (MHz)	Distance cm	Azimuth degrees	Elevation cm	Probe Display V/m	Probe Factor	Field Strength V/m	Power Density mW/cm <sup>2</sup>	FCC Limit mW/cm <sup>2</sup>	ISED Canada Limit mW/cm <sup>2</sup>	Result
914.8	20	0	152	11.468	1.26	14.450	0.055	0.610	0.277	PASS
914.8	20	45	153	8.189	1.26	10.318	0.028	0.610	0.277	PASS
914.8	20	90	160	6.021	1.26	7.586	0.015	0.610	0.277	PASS
914.8	20	135	158	7.201	1.26	9.073	0.022	0.610	0.277	PASS
914.8	20	180	166	7.91	1.26	9.967	0.026	0.610	0.277	PASS
914.8	20	225	176	6.475	1.26	8.159	0.018	0.610	0.277	PASS
914.8	20	270	152	9.402	1.26	11.847	0.037	0.610	0.277	PASS
914.8	20	315	151	10.538	1.26	13.278	0.047	0.610	0.277	PASS

**Table 7.1.2-2: Maximum Permissible Exposure – 802.11 Radio**

Frequency (MHz)	Distance cm	Azimuth degrees	Elevation cm	Probe Display V/m	Probe Factor	Field Strength V/m	Power Density mW/cm <sup>2</sup>	FCC Limit mW/cm <sup>2</sup>	ISED Canada Limit mW/cm <sup>2</sup>	Result
2437	20	0	161	1.151	1.38	1.588	0.001	1.000	0.540	PASS
2437	20	45	172	0.741	1.38	1.023	0.000	1.000	0.540	PASS
2437	20	90	166	0.758	1.38	1.046	0.000	1.000	0.540	PASS
2437	20	135	165	0.718	1.38	0.991	0.000	1.000	0.540	PASS
2437	20	180	173	0.979	1.38	1.351	0.000	1.000	0.540	PASS
2437	20	225	151	0.675	1.38	0.932	0.000	1.000	0.540	PASS
2437	20	270	155	0.713	1.38	0.984	0.000	1.000	0.540	PASS
2437	20	315	103	0.881	1.38	1.216	0.000	1.000	0.540	PASS

**Table 7.1.2-3: Maximum Permissible Exposure – RN-ERT Gateway STAR**

Frequency (MHz)	Maximum Exposure mW/cm <sup>2</sup>	Maximum Exposure W/m <sup>2</sup>	FCC Limit mW/cm <sup>2</sup>	ISED Canada Limit W/m <sup>2</sup>
915	0.180	1.800	0.600	2.700

Note: The measured values from Table 7.1.2-3 were taken from the maximum permissible exposure report of the original filing of the RN-ERT Gateway STAR (FCC ID: EO9ORRNA). These values are included in this report for summation of maximum permissible exposure with the SNIC1 and were not measured during this evaluation.

### 7.1.3 Summation of MPE Ratios – Simultaneous Transmissions

Performed by: Ryan McGann

This device contains multiple transmitters which can operate simultaneously; therefore, the maximum RF exposure is determined by the summation of MPE ratios. The limit is such that the summation of MPE ratios is  $\leq 1.0$ .

**Table 7.1.3-1: Summation of MPE Ratios – FCC**

	Scenario 1
900MHz ISM	x
2.4GHz ISM	x
900 MHz ISM (RN-ERT Gateway STAR)	x
900MHz ISM MPE Ratio	0.0908
2.4GHz ISM MPE Ratio	0.0007
900 MHz ISM (RN-ERT Gateway STAR) MPE Ratio	0.2951
MPE Ratio Summation:	0.3865

**Table 7.1.3-2: Summation of MPE Ratios – ISED Canada**

	Scenario 1
900MHz ISM	x
2.4GHz ISM	x
900 MHz ISM (RN-ERT Gateway STAR)	x
900MHz ISM MPE Ratio	0.1983
2.4GHz ISM MPE Ratio	0.0012
900 MHz ISM (RN-ERT Gateway STAR) MPE Ratio	0.6506
MPE Ratio Summation:	0.8501

**8 ESTIMATION OF MEASUREMENT UNCERTAINTY**

The expanded laboratory measurement uncertainty figures ( $U_{\text{Lab}}$ ) provided below correspond to an expansion factor (coverage factor)  $k = 1.96$  which provide confidence levels of 95%.

Parameter	$U_{\text{lab}}$
Electric Field	39.12%

**9 CONCLUSION**

In the opinion of TÜV SÜD America, Inc. the SNIC1, manufactured by Itron, Inc. meets the requirements of FCC Part 1 subpart I and Innovation, Science, and Economic Development Canada's Radio Standards Specification RSS-102 for the tests documented in this test report.

**END REPORT**