

Certification Test Report

FCC ID: SK9PMCR2

IC: 864G-PMCR2

FCC Rule Part: 15.247

IC Radio Standards Specification: RSS-210

ACS Report Number: 10-0031.W04.11.A

Manufacturer: Itron Electricity Metering, Inc.

Model: PMCR2

Test Begin Date: February 3, 2010

Test End Date: February 4, 2010

Report Issue Date: February 8, 2010



FOR THE SCOPE OF ACCREDITATION UNDER LAB Code 200612-0

This report is not be used to claim certification, approval, or endorsement by NVLAP, NIST or any government agency.

Prepared by: _____

A handwritten signature in black ink, appearing to read "Kirby Munroe", is written over a horizontal line.

Kirby Munroe

Director, Wireless Certifications

ACS, Inc.

This test report shall not be reproduced except in full. This report may be reproduced in part with prior written consent of ACS, Inc. The results contained in this report are representative of the sample(s) submitted for evaluation.

This report contains 23 pages

TABLE OF CONTENTS

1	GENERAL	3
1.1	PURPOSE.....	3
1.2	PRODUCT DESCRIPTION	3
1.3	TEST METHODOLOGY AND CONSIDERATIONS	3
2	TEST FACILITIES	4
2.1	LOCATION	4
2.2	LABORATORY ACCREDITATIONS/RECOGNITIONS/CERTIFICATIONS	4
2.3	RADIATED EMISSIONS TEST SITE DESCRIPTION	5
2.3.1	<i>Semi-Anechoic Chamber Test Site</i>	5
2.3.2	<i>Open Area Tests Site (OATS)</i>	6
2.4	CONDUCTED EMISSIONS TEST SITE DESCRIPTION	7
3	APPLICABLE STANDARD REFERENCES	7
4	LIST OF TEST EQUIPMENT	8
5	SUPPORT EQUIPMENT	9
6	EQUIPMENT UNDER TEST SETUP BLOCK DIAGRAM	9
7	SUMMARY OF TESTS	10
7.1	PEAK OUTPUT POWER - FCC SECTION 15.247(B)(2) IC: RSS-210 A8.4(1).....	10
7.1.1	<i>Measurement Procedure (Conducted Method)</i>	10
7.1.2	<i>Measurement Results</i>	10
7.2	20dB / 99% BANDWIDTH - FCC: SECTION 15.247(A)(1)(i) IC: RSS-210 A8.1(c).....	12
7.2.1	<i>Measurement Procedure</i>	12
7.2.2	<i>Measurement Results</i>	12
7.3	BAND-EDGE COMPLIANCE AND SPURIOUS EMISSIONS-FCC 15.247D IC:RSS-210 2.6, A8.5	16
7.3.1	<i>Band-Edge Compliance of RF Conducted Emissions</i>	16
7.3.1.1	<i>Measurement Procedure</i>	16
7.3.1.2	<i>Measurement Results</i>	16
7.3.2	<i>RF Conducted Spurious Emissions</i>	19
7.3.2.1	<i>Measurement Procedure</i>	19
7.3.2.2	<i>Measurement Results</i>	19
7.3.3	<i>Radiated Spurious Emissions - FCC Section 15.205 IC: RSS-210 2.6</i>	23
7.3.3.1	<i>Measurement Procedure</i>	23
7.3.3.2	<i>Measurement Results</i>	23
8	CONCLUSION	23

1 GENERAL

1.1 Purpose

The purpose of this report is to demonstrate compliance with Part 15 Subpart C of the FCC's Code of Federal Regulations and Industry Canada's Radio Standards Specification RSS-210 for a Class II Permissive Change.

This Class II Permissive Change report is to address a new data rate of 153.6 kbps.

1.2 Product description

This product is a pole mountable version of Itron's OpenWay Cell Relay product with an Ethernet only backhaul. The PMCR2 is an ANSI C12.22 relay that routes meter data traffic from a proprietary 900 MHz RFLAN mesh network to a Collection Engine server via a wide area network IP backhaul. The PMCR2 performs C12.22 aptitle and routing translations on the data it is routing. The PMCR2 also contains two short range Zigbee radios that are used for wireless device configuration.

The PMCR2 also includes a pre-approved cellular modem FCC ID: N7NMC8790 / IC: 2417C-MC8790.

Manufacturer Information:
Itron Electricity Metering, Inc.
313 North Highway 11
West Union, SC 29696

Test Sample Serial Number(s): FCC Certification Unit

1.3 Test Methodology and Considerations

The EUT was tested in a configuration typical of normal use.

This device is considered a composite device by definition. The 900 MHz LAN and high power 2.4 GHz Zigbee radios operate under CFR 47 Part 15.247 and IC RSS-210. The low power 2.4 GHz Zigbee radio operates under CFR 47 Part 15.249 and IC RSS-210. The data rate change affects the 900 MHz LAN only therefore this report addresses Part 15.247 and RSS 210 for the 900 MHz radio portion only.

See test setup photographs for additional information.

2 TEST FACILITIES

2.1 Location

The radiated and conducted emissions test sites are located at the following address:

Advanced Compliance Solutions
5015 B.U. Bowman Drive
Buford, GA 30518
Phone: (770) 831-8048
Fax: (770) 831-8598

2.2 Laboratory Accreditations/Recognitions/Certifications

The Semi-Anechoic Chamber Test Site, Open Area Test Site (OATS) and Conducted Emissions Site have been fully described, submitted to, and accepted by the FCC, Industry Canada and the Japanese Voluntary Control Council for Interference by information technology equipment. In addition, ACS is compliant to ISO/IEC 17025 as certified by the National Institute of Standards and Technology under their National Voluntary Laboratory Accreditation Program. The following certification numbers have been issued in recognition of these accreditations and certifications:

FCC Registration Number: 894540

Industry Canada Lab Code: IC 4175A-1

VCCI Member Number: 1831

- VCCI OATS Registration Number R-1526
- VCCI Conducted Emissions Site Registration Number: C-1608

NVLAP Lab Code: 200612-0

2.3 Radiated Emissions Test Site Description

2.3.1 Semi-Anechoic Chamber Test Site

The Semi-Anechoic Chamber Test Site consists of a 20' x 30' x 18' shielded enclosure. The chamber is lined with Toyo Ferrite Grid Absorber, model number FFG-1000. The ferrite tile grid is 101 x 101 x 19mm thick and weighs approximately 550 grams. These tiles are mounted on steel panels and installed directly on the inner walls of the chamber.

The turntable is 150cm in diameter and is located 160cm from the back wall of the chamber. The chamber is grounded via 1 - 8' copper ground rod, installed at the center of the back wall, it is bound to the ground plane using 3/4" stainless steel braided cable.

The turntable is all steel, flush mounted table installed in an all steel frame. The table is remotely operated from inside the control room located 25' from the range. The turntable is electrically bonded to the surrounding ground plane via steel fingers installed on the edge of the turn table. The steel fingers make constant contact with the ground plane during operation.

Behind the turntable is a 3' x 6' x 4' deep shielded pit used for support equipment if necessary. The pit is equipped with 1 - 4" PVC chases from the turntable to the pit that allow for cabling to the EUT if necessary. The underside of the turntable can be accessed from the pit so cables can be supplied to the EUT from the pit.

A diagram of the Semi-Anechoic Chamber Test Site is shown in Figure 2.3-1 below:

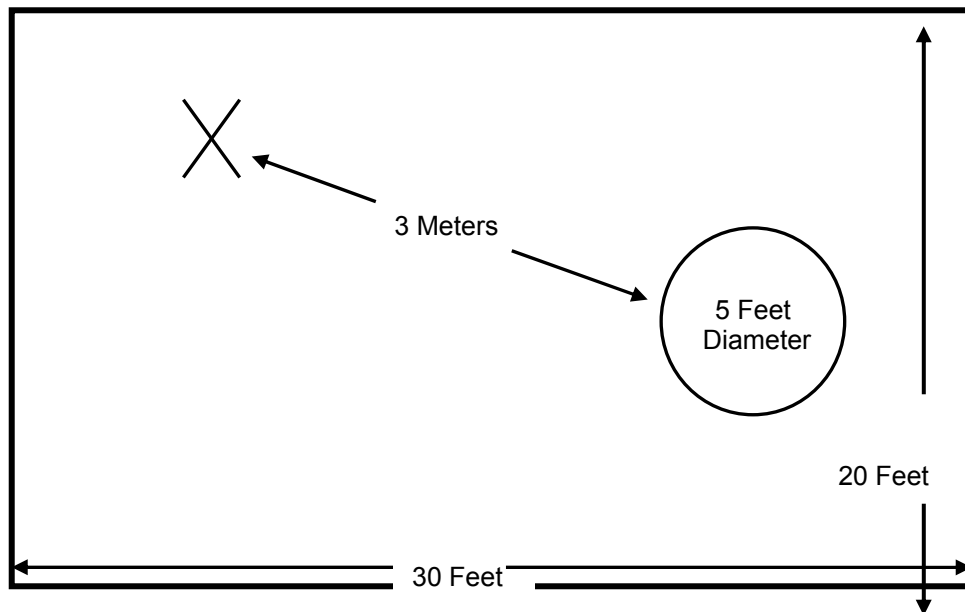

Figure 2.3-1: Semi-Anechoic Chamber Test Site

2.3.2 Open Area Tests Site (OATS)

The open area test site consists of a 40' x 66' concrete pad covered with a perforated electro-plated galvanized sheet metal. The perforations in the sheet metal are 1/8" holes that are staggered every 3/16". The individual sheets are placed to overlap each other by 1/4" and are riveted together to provide a continuous seam. Rivets are spaced every 3" in a 3 x 20 meter perimeter around the antenna mast and EUT area. Rivets in the remaining area are spaced as necessary to properly secure the ground plane and maintain the electrical continuity.

The entire ground plane extends 12' beyond the turntable edge and 16' beyond the antenna mast when set to a 10 meter measurement distance. The ground plane is grounded via 4 - 8' copper ground rods, each installed at a corner of the ground plane and bound to the ground plane using 3/4" stainless steel braided cable.

The turntable is an all aluminum 10' flush mounted table installed in an all aluminum frame. The table is remotely operated from inside the control room located 40' from the range. The turntable is electrically bonded to the surrounding ground plane via steel fingers installed on the edge of the turn table. The steel fingers make constant contact with the ground plane during operation.

Adjacent to the turntable is a 7' x 7' square and 4' deep concrete pit used for support equipment if necessary. The pit is equipped with 5 - 4" PVC chases from the pit to the control room that allow for cabling to the EUT if necessary. The underside of the turntable can be accessed from the pit so cables can be supplied to the EUT from the pit. The pit is covered with 2 sheets of 1/4" diamond style re-enforced steel sheets. The sheets are painted to match the perforated steel ground plane; however the underside edges have been masked off to maintain the electrical continuity of the ground plane. All reflecting objects are located outside of the ellipse defined in ANSI C63.4.

A diagram of the Open Area Test Site is shown in Figure 2.3-2 below:

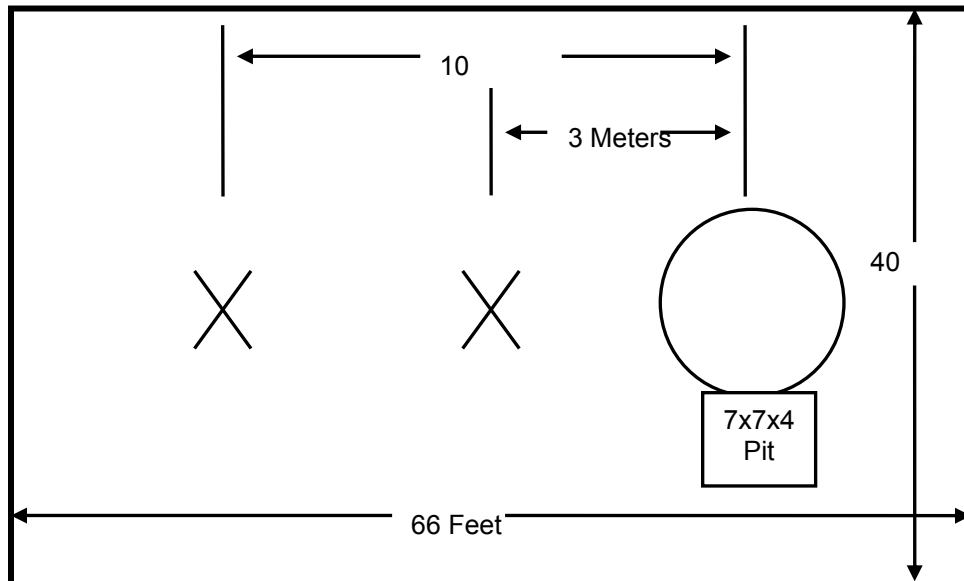

Figure 2.3-2: Open Area Test Site

2.4 Conducted Emissions Test Site Description

The AC mains conducted EMI site is located in the main EMC lab. It consists of an 8' x 8' solid aluminum horizontal group reference plane (GRP) bonded every 3" to an 8' X 8' vertical ground plane.

The site is of sufficient size to test table top and floor standing equipment in accordance with section 6.1.4 of ANSI C63.4.

A diagram of the room is shown below in figure 4.1.3-1:

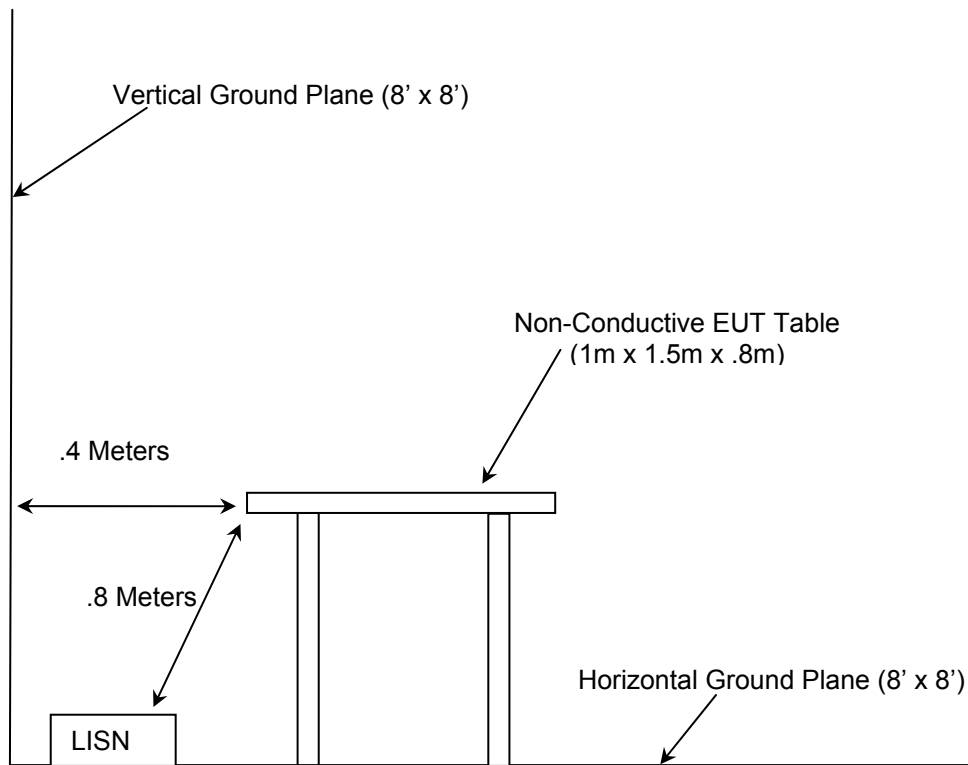

Figure 2.4-1: AC Mains Conducted EMI Site

3 APPLICABLE STANDARD REFERENCES

The following standards were used:

- ❖ ANSI C63.4-2003: Method of Measurements of Radio-Noise Emissions from Low-Voltage Electrical and Electronic Equipment in the 9KHz to 40GHz
- ❖ US Code of Federal Regulations (CFR): Title 47, Part 2, Subpart J: Equipment Authorization Procedures, 2009
- ❖ US Code of Federal Regulations (CFR): Title 47, Part 15, Subpart C: Radio Frequency Devices, Intentional Radiators, 2009
- ❖ FCC Public Notice DA 00-705 - Filing and Measurement Guidelines for Frequency Hopping Spread Spectrum Systems, March 30, 2000
- ❖ Industry Canada Radio Standards Specification: RSS-210 - Low-power License-exempt Radiocommunication Devices (All Frequency Bands): Category I Equipment, Issue 7 June 2007
- ❖ Industry Canada Radio Standards Specification: RSS-GEN – General Requirements and Information for the Certification of Radiocommunication Equipment, Issue2, June 2007.

4 LIST OF TEST EQUIPMENT

The calibration interval of test equipment is annually or the manufacturer's recommendations. Where the calibration interval deviates from the annual cycle based on the instrument manufacturer's recommendations, it shall be stated below.

Table 4-1: Test Equipment

Equipment Calibration Information					
ACS#	Mfg.	Eq. type	Model	S/N	Cal. Due
1	Rohde & Schwarz	Spectrum Analyzers	ESMI - Display	833771/007	09-21-2010
2	Rohde & Schwarz	Spectrum Analyzers	ESMI-Receiver	839587/003	09-21-2010
338	Hewlett Packard	Amplifiers	8449B	3008A01111	10-16-2010
25	Chase	Antennas	CBL6111	1043	09-02-2010
30	Spectrum Technologies	Antennas	DRH-0118	970102	05-08-2010
73	Agilent	Amplifiers	8447D	2727A05624	07-15-2010
167	ACS	Cable Set	Chamber EMI Cable Set	167	02-06-2010 (See Note1)
283	Rohde & Schwarz	Spectrum Analyzers	FSP40	1000033	09-21-2010
291	Florida RF Cables	Cables	SMRE-200W-12.0-SMRE	None	11-24-2010 (See Note1)
292	Florida RF Cables	Cables	SMR-290AW-480.0-SMR	None	11-24-2010 (See Note1)
337	Microwave Circuits	Filter	H1G513G1	282706	07-17-2010
339	Aeroflex/Weinschel	Attenuators	AS-18	7142	07-02-2010 (See Note2)
422	Florida RF Cables	Cables	SMS-200AW-72.0-SMR	0805	02-05-2010 (See Note1)

Note1: Items characterized on an annual cycle. The date shown indicates the next characterization due date.

Note2: Items verified on an annual cycle. The date shown indicates the next verification due date.

5 SUPPORT EQUIPMENT

Table 5-1: Support Equipment

Item	Equipment Type	Manufacturer	Model Number	Serial Number / Part Number	FCC ID
1	EUT	Itron	PMCR2	FCC Certification Unit	SK9PMCR2
2	5 Port Router	Linksys	SD2005	RED30H603862	NA
3	Power Supply	Linksys	D12-50-A	GPSAS3-12P506-AM7HK	NA

6 EQUIPMENT UNDER TEST SETUP BLOCK DIAGRAM

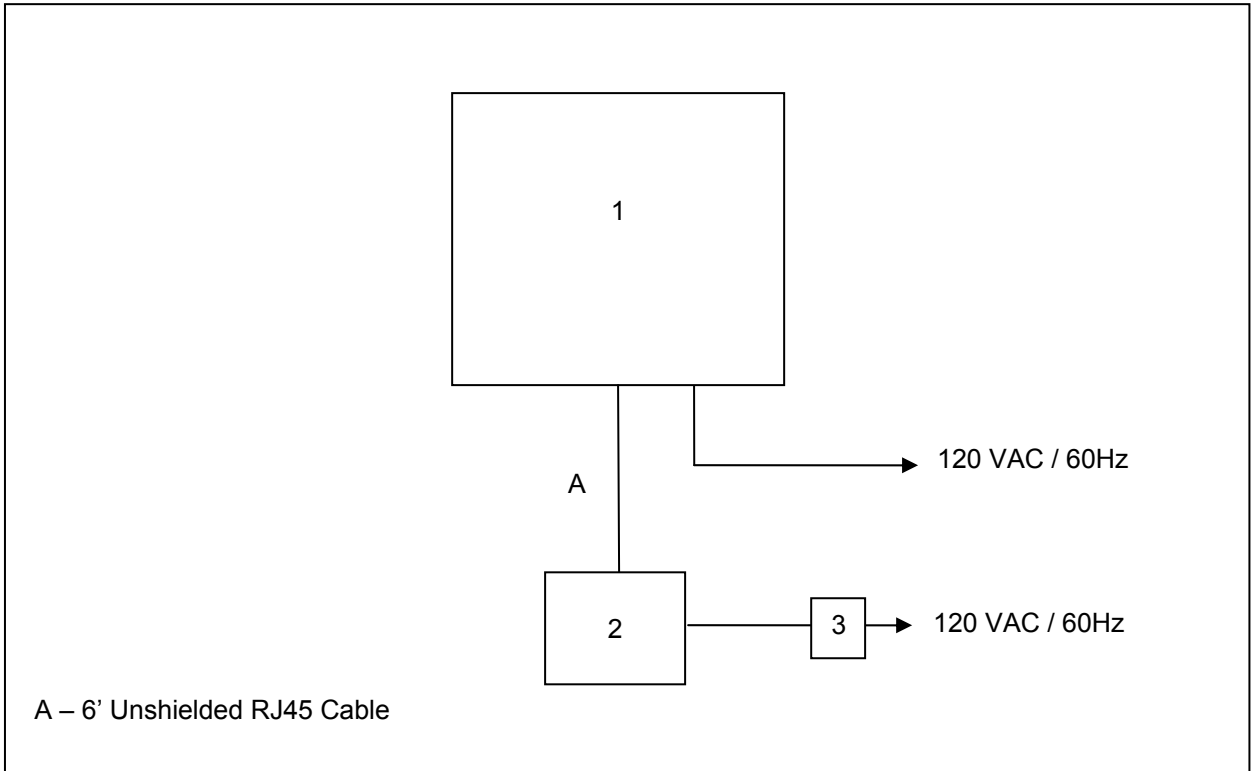

7 SUMMARY OF TESTS

Along with the tabular data shown below, plots were taken of all signals deemed important enough to document.

7.1 Peak Output Power - FCC Section 15.247(b)(2) IC: RSS-210 A8.4(1)

7.1.1 Measurement Procedure (Conducted Method)

The 20dB bandwidth of the EUT was within the resolution bandwidth of spectrum analyzer, therefore the power measurement was made using the spectrum analyzer method. The RF output port of the EUT was directly connected to the input of the spectrum analyzer. The resolution and video bandwidth were set to > 20 dB bandwidth of the emission measured. The device employs >50 channels therefore the power is limited to 1 Watt.

7.1.2 Measurement Results

Results are shown below in table 7.1.2-1 and the worst case was plotted and shown in figure 7.1.2-1 to 7.1.2-3 below:

Table 7.1.2-1: RF Output Power

Frequency (MHz)	Output Power (dBm)
902.25	26.62
914.75	26.19
927.75	25.49

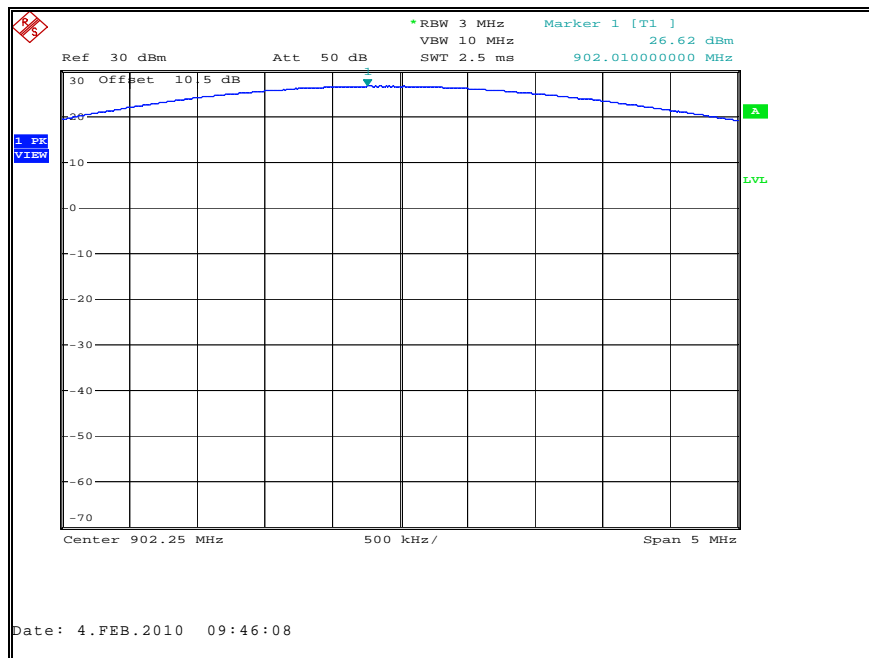

Figure 7.1.2-1: Output power – Low Channel

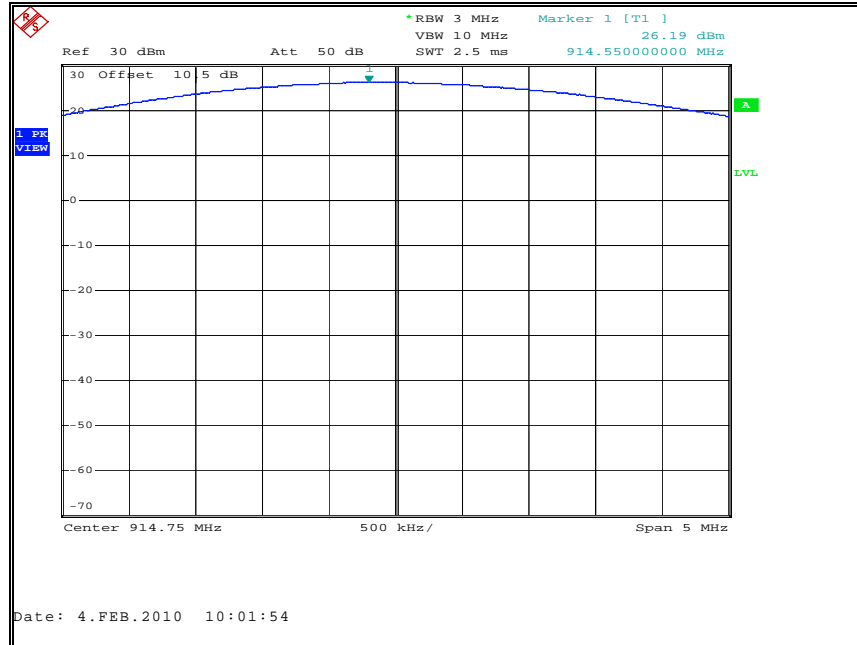

Figure 7.1.2-2: Output power – Mid Channel

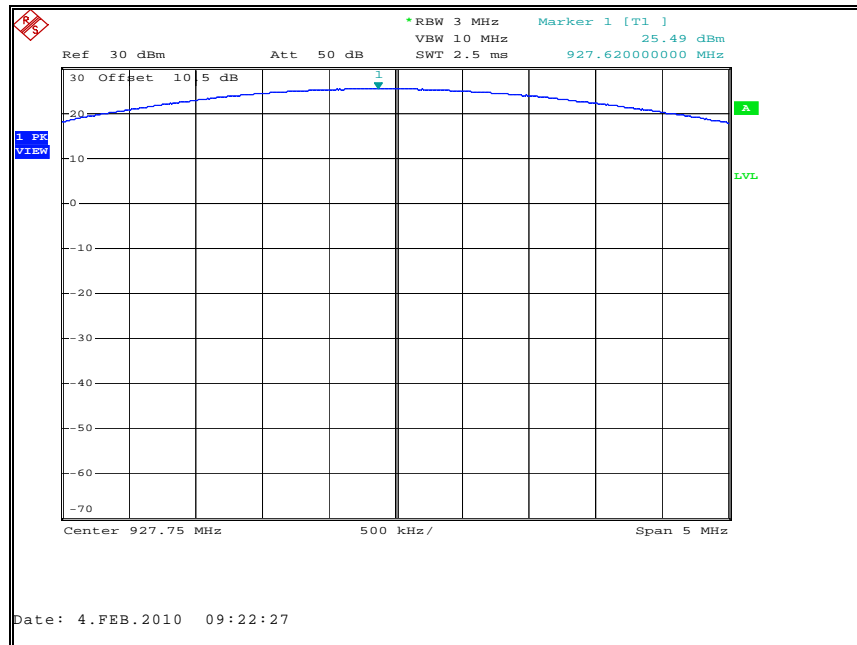

Figure 7.1.2-3: Output power – High Channel

7.2 20dB / 99% Bandwidth - FCC: Section 15.247(a)(1)(i) IC: RSS-210 A8.1(c)

7.2.1 Measurement Procedure

The RF output port of the EUT was directly connected to the input of the spectrum analyzer. The spectrum analyzer span was set to 2 to 3 times the estimated bandwidth of the emission. The RBW was to $\geq 1\%$ of the estimated emission bandwidth. The trace was set to max hold with a peak detector active. The Delta function of the analyzer was utilized to determine the 20 dB bandwidth of the emission.

The 99% occupied bandwidth was measured with the spectrum analyzer span set to fully display the emission and approximately 20dB below the peak level. The RBW was to 1% to 3% of the approximate emission width. The trace was set to max hold with a peak detector active. The occupied bandwidth measurement function of the analyzer was used for the 99% bandwidth.

7.2.2 Measurement Results

Results are shown below in Table 7.2.2-1 and Figures 7.2.2-1 through 7.2.2-6.

Table 7.2.2-1: 20dB / 99% Bandwidth

Frequency [MHz]	20dB Bandwidth [kHz]	99% Bandwidth [kHz]
902.25	364.0	350.0
914.75	348.0	348.0
927.75	368.0	346.0



Figure 7.2.2-1: 20dB Bandwidth Plot – Low Channel



Figure 7.2.2-2: 20dB Bandwidth Plot – Mid Channel



Figure 7.2.2-3: 20dB Bandwidth Plot – High Channel

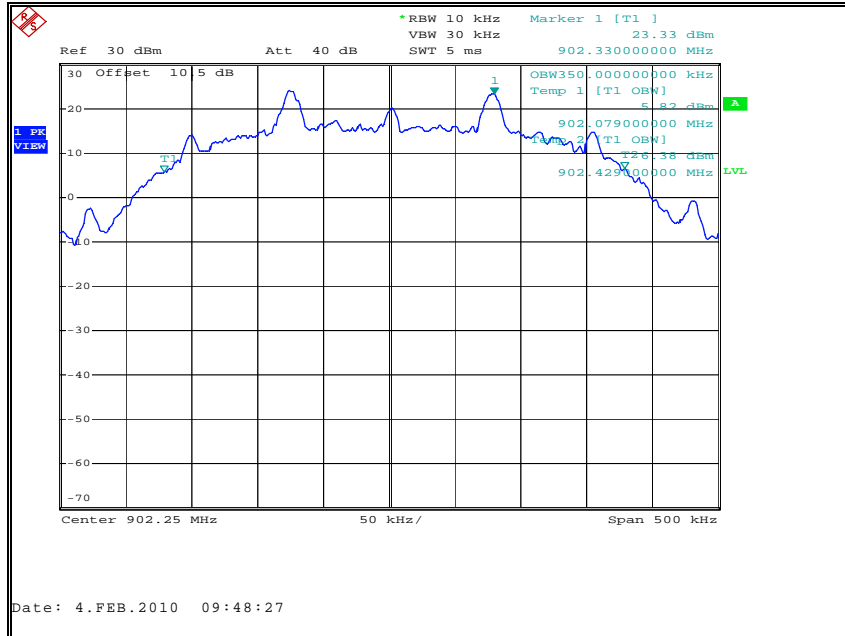

Figure 7.2.2-4: 99% Bandwidth Plot – Low Channel

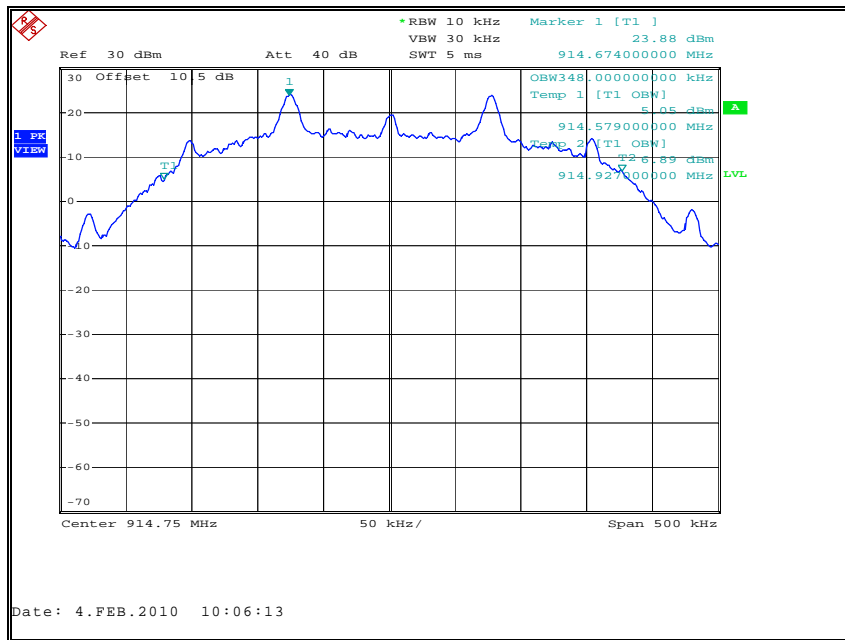

Figure 7.2.2-5: 99% Bandwidth Plot – Mid Channel

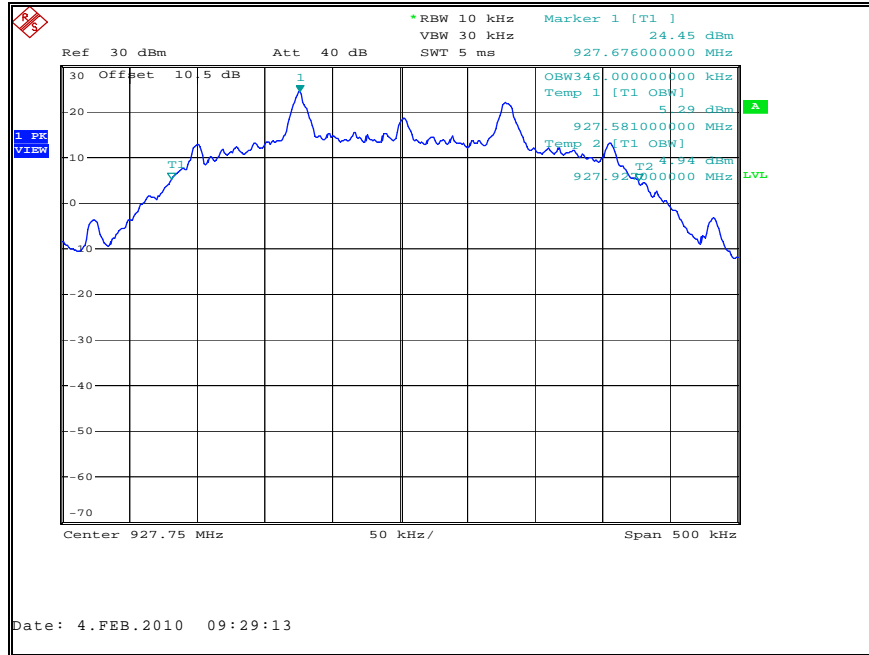

Figure 7.2.2-6: 99% Bandwidth Plot – High Channel

7.3 Band-Edge Compliance and Spurious Emissions-FCC 15.247d IC:RSS-210 2.6, A8.5

7.3.1 Band-Edge Compliance of RF Conducted Emissions

7.3.1.1 Measurement Procedure

The RF output port of the EUT was directly connected to the input of the spectrum analyzer. The EUT was investigated at the lowest and highest channel available to determine band-edge compliance. For each measurement the spectrum analyzer's RBW was set to 30 kHz, which is $\geq 1\%$ of the span, and the VBW was set to 100kHz.

7.3.1.2 Measurement Results

Results are shown in the figures 7.3.1.2-1 to 7.3.1.4 below.

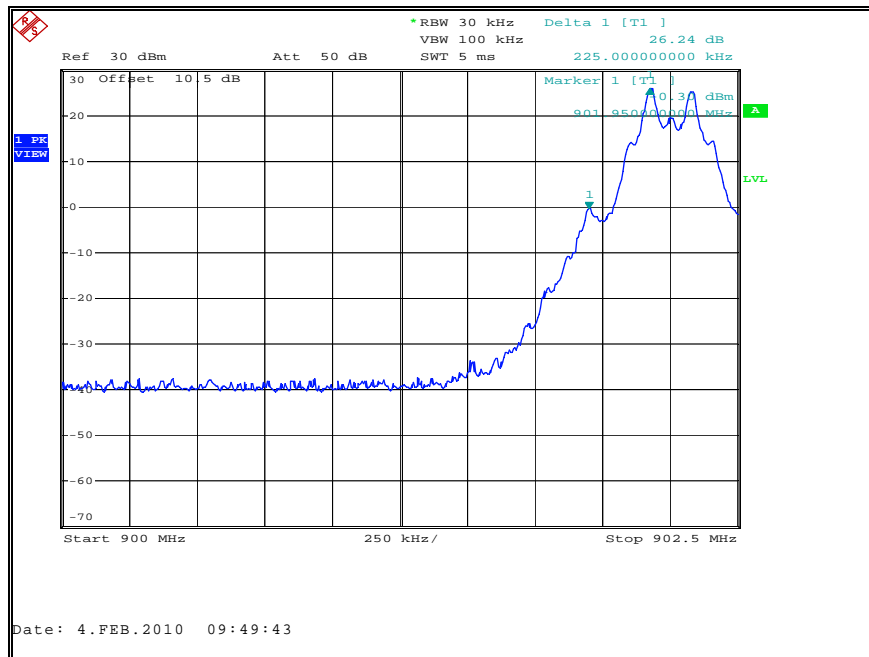

Figure 7.3.1.2-1: Lower Band-edge

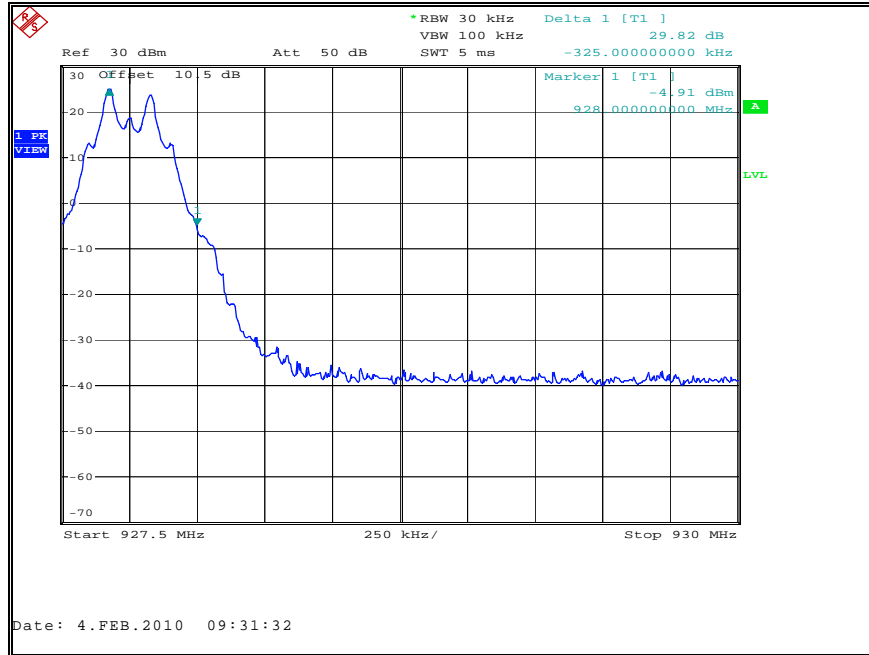

Figure 7.3.1.2-2: Upper Band-edge



Figure 7.3.1.2-3: Lower Band-edge – Hopping

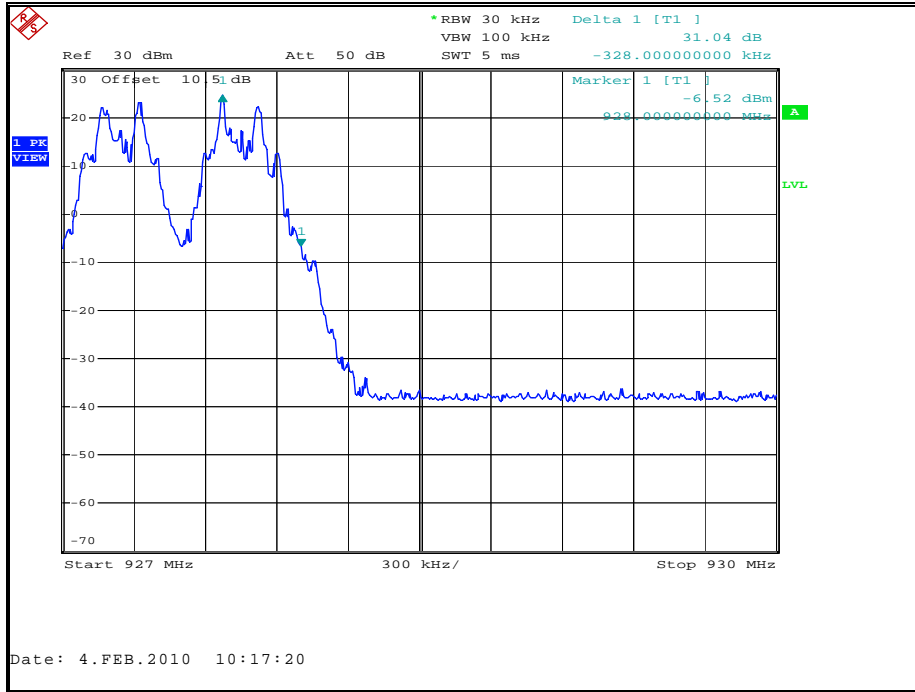

Figure 7.3.1.2-4: Upper Band-edge - Hopping

7.3.2 RF Conducted Spurious Emissions

7.3.2.1 Measurement Procedure

The RF output port of the EUT was directly connected to the input of the spectrum analyzer. The EUT was investigated for conducted spurious emissions from 30MHz to 10GHz, 10 times the highest fundamental frequency. Measurements were made at the low, center and high channels of the EUT. For each measurement, the spectrum analyzer's RBW was set to 100kHz. A peak detector function was used with the trace set to max hold.

7.3.2.2 Measurement Results

Results are shown below in Figures 7.3.2.2-1 to 7.3.2.2-6:

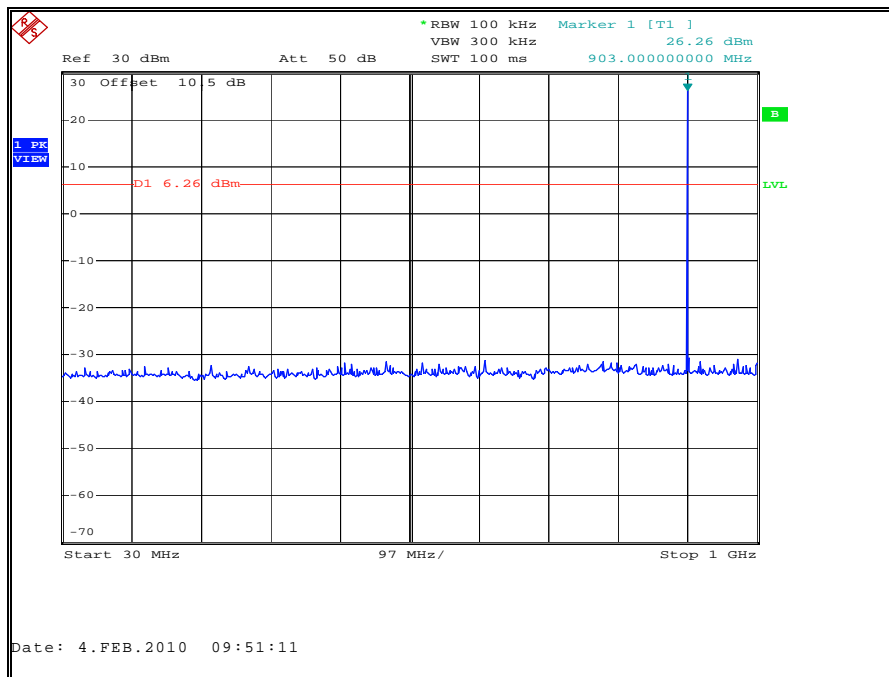

Figure 7.3.2.2-1: 30 MHz – 1 GHz – Low Channel

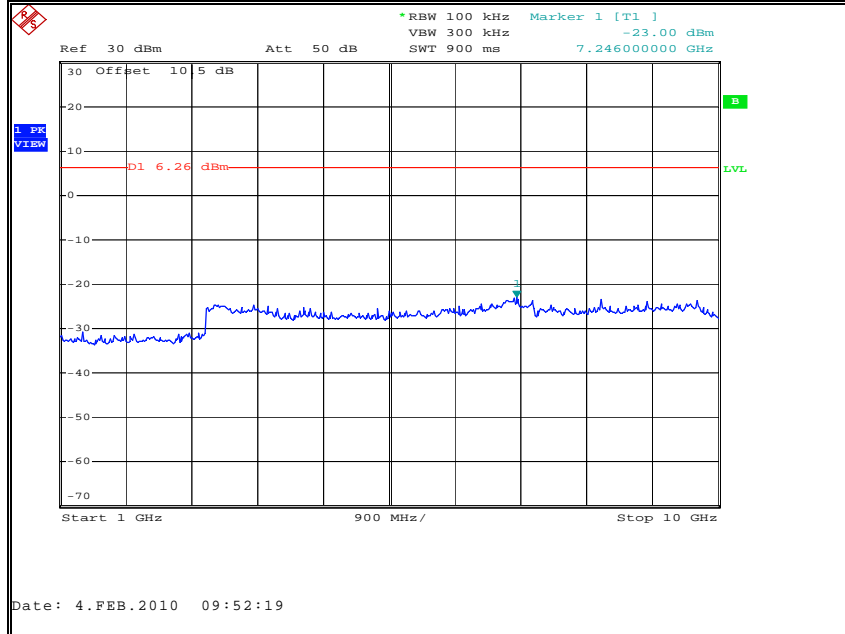

Figure 7.3.2.2-2: 1 GHz – 10 GHz – Low Channel

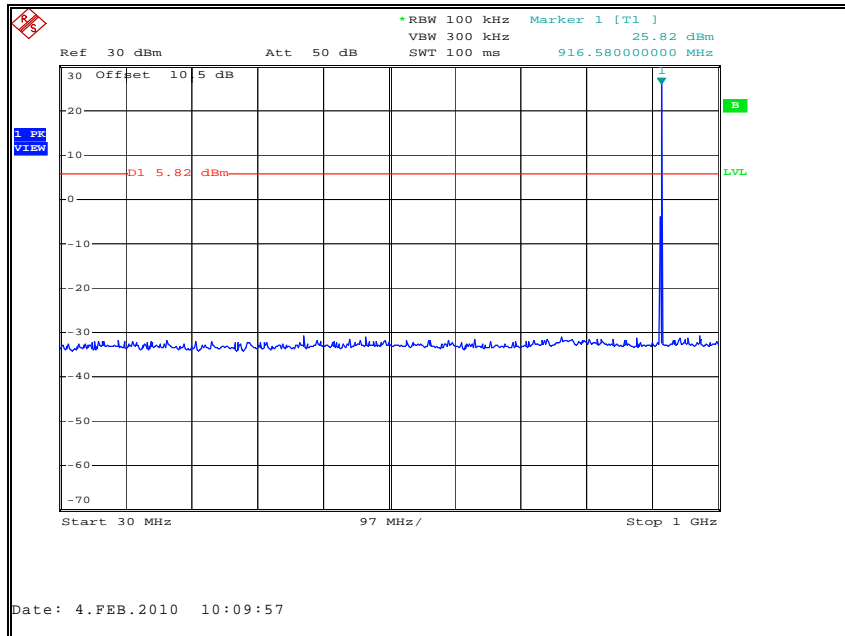

Figure 7.3.2.2-3: 30 MHz – 1 GHz –Mid Channel

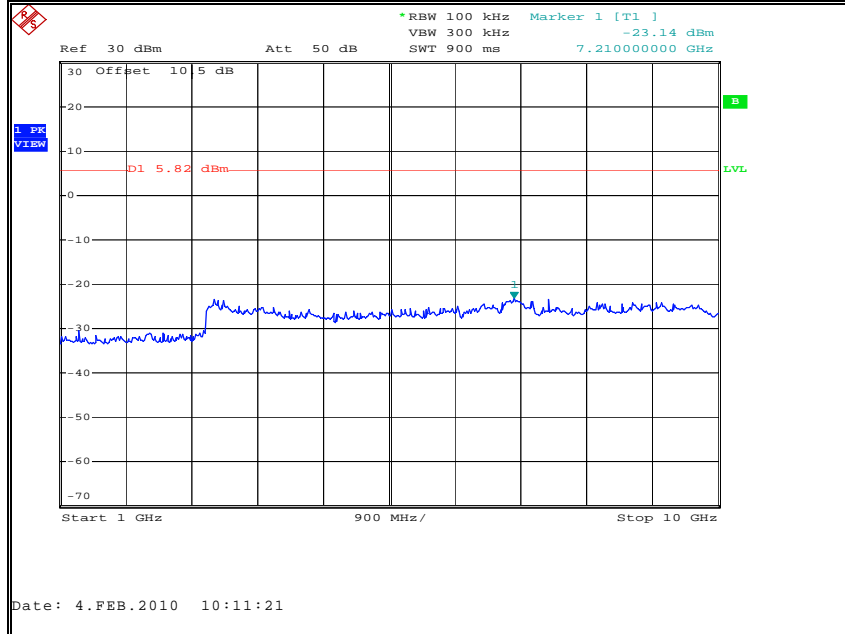

Figure 7.3.2.2-4: 1 GHz – 10 GHz – Mid Channel

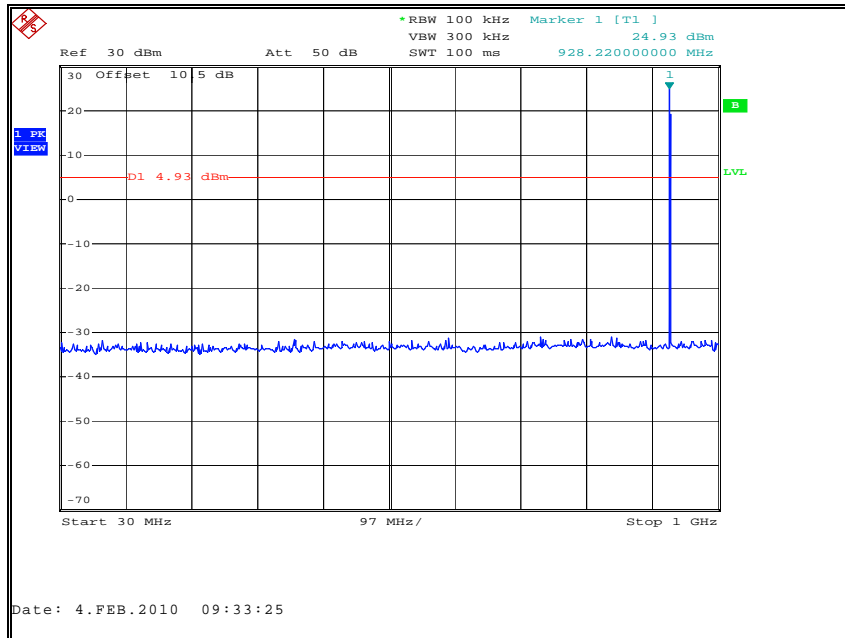

Figure 7.3.2.2-5: 30 MHz – 1 GHz – High Channel

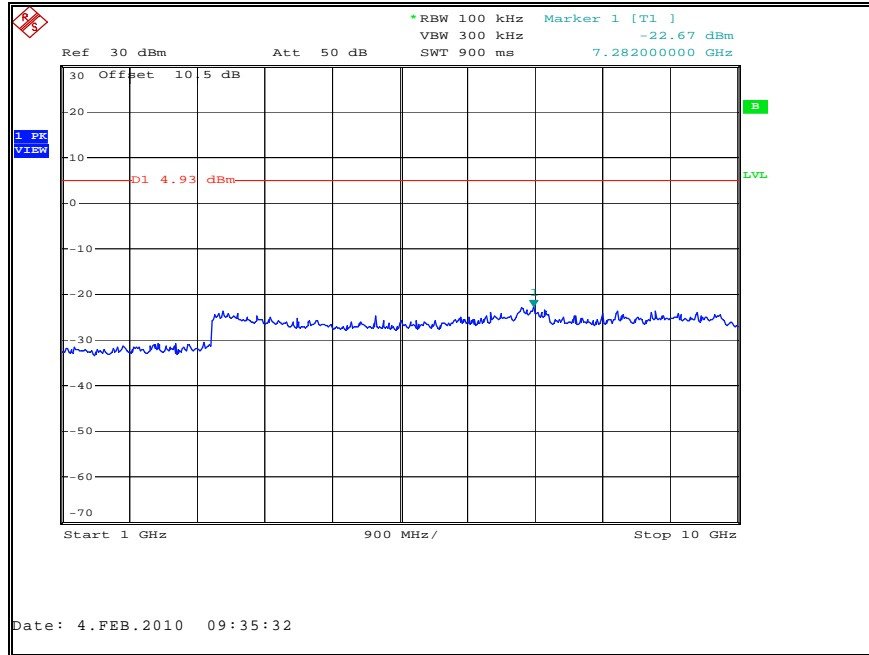

Figure 7.3.2.2-6: 1 GHz – 10 GHz –High Channel

7.3.3 Radiated Spurious Emissions - FCC Section 15.205 IC: RSS-210 2.6**7.3.3.1 Measurement Procedure**

Radiated emissions tests were made over the frequency range of 30MHz to 10GHz, 10 times the highest fundamental frequency.

The EUT was rotated through 360° and the receive antenna height was varied from 1m to 4m so that the maximum radiated emissions level would be detected. For frequencies below 1000MHz, quasi-peak measurements were made using a resolution bandwidth RBW of 120 kHz and a video bandwidth VBW of 300 kHz. For frequencies above 1000MHz, peak and average measurements made with RBW and VBW of 1 MHz and 3MHz respectively.

The EUT was caused to generate a continuous carrier signal on the hopping channel.

The magnitudes of all emissions not reported were below the noise floor of the measurement system.

7.3.3.2 Measurement Results

There were no emissions detected above the noise floor of the measurement system.

8 CONCLUSION

In the opinion of ACS, Inc. the PMCR2, manufactured by Itron Electricity Metering, Inc. continues to meet the requirements of FCC Part 15 subpart C and Industry Canada's Radio Standards Specification RSS-210.

END REPORT