

NOTES:

1. SPLIT BALLOONS CONTAIN ITEM NUMBER IN THE TOP PORTION AND QUANTITY IN THE BOTTOM PORTION.

2. REMOVE MOUNTING BRACKET (AS REQUIRED) TO INSTALL THE LABELS. TO REPLACE, ALIGN BRACKET AS SHOWN AND TWIST CLOCKWISE TO LOCK IN PLACE.

3. AFFIX THE SECONDARY LABELS TO THE PRE-INSTALLED PRODUCT LABEL AS INDICATED.

REVISIONS				
ZONE	REV.	DESCRIPTION	DATE	APPROVED
	A	INITIAL RELEASE	5/28/2008	I. LAITY

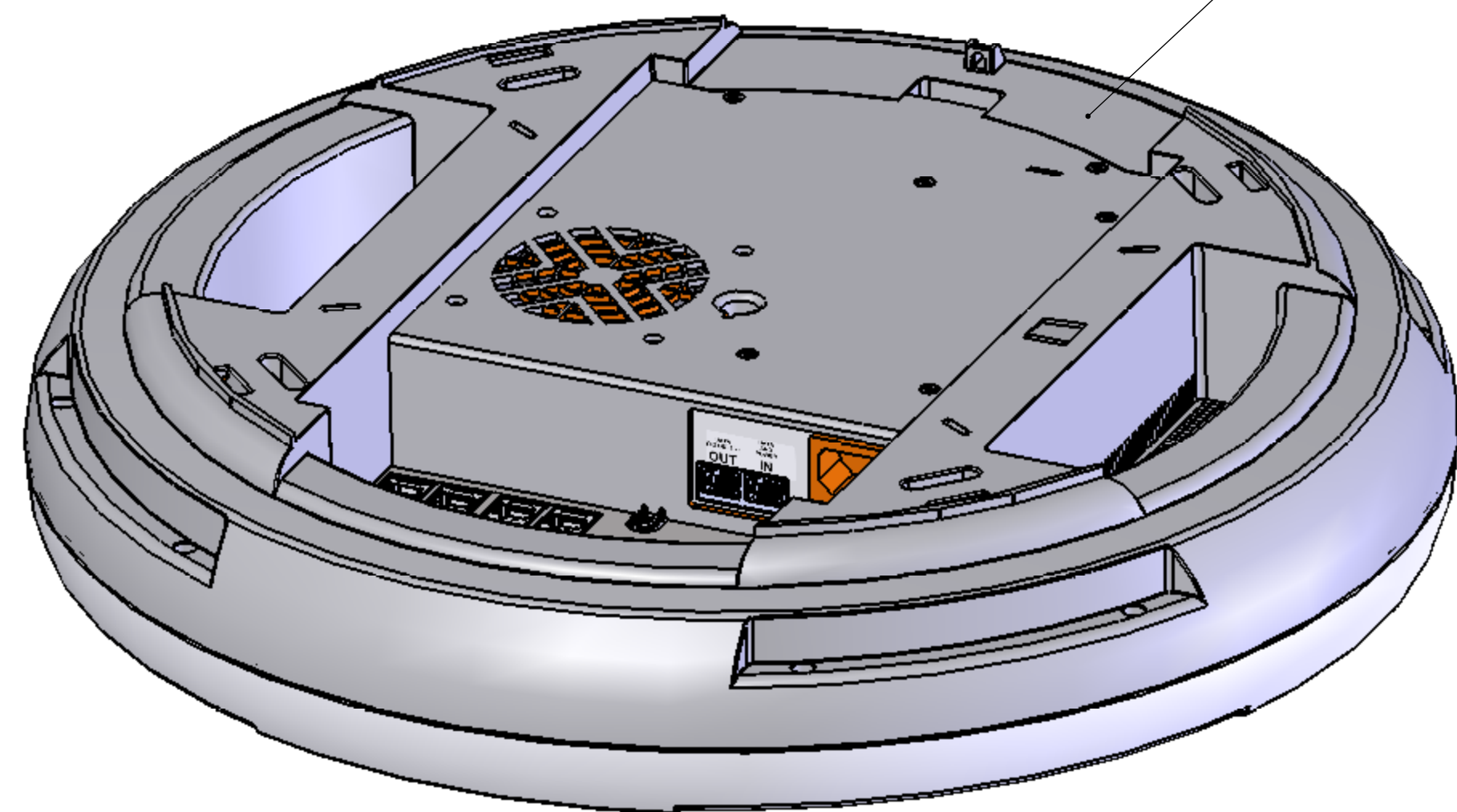
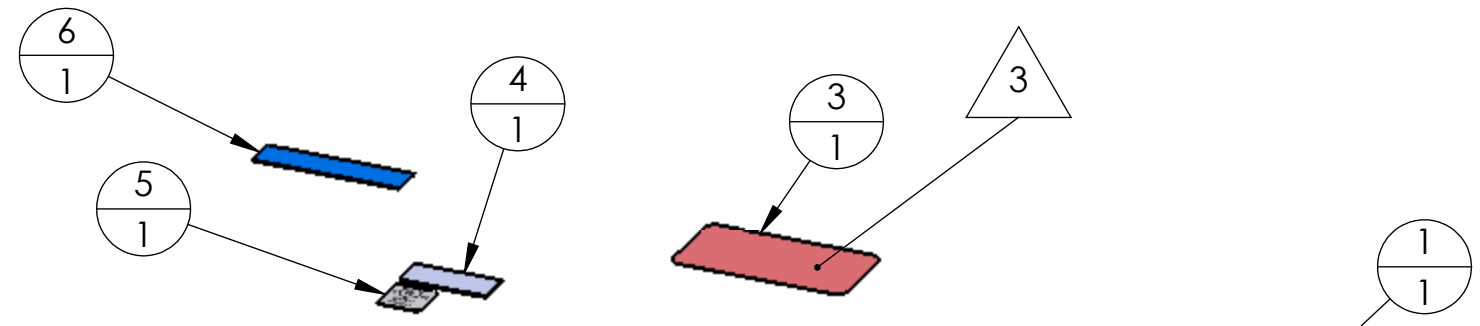
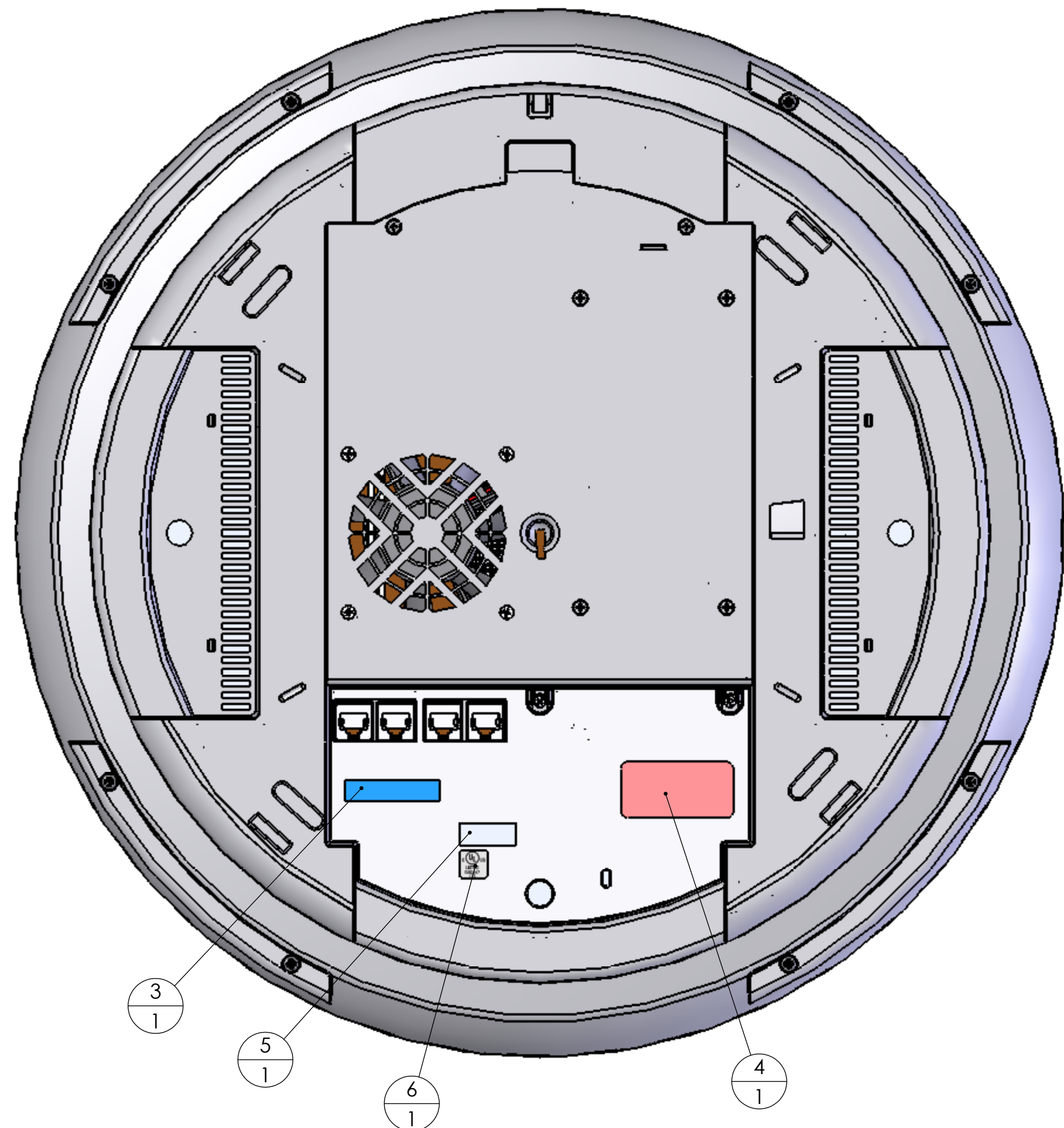
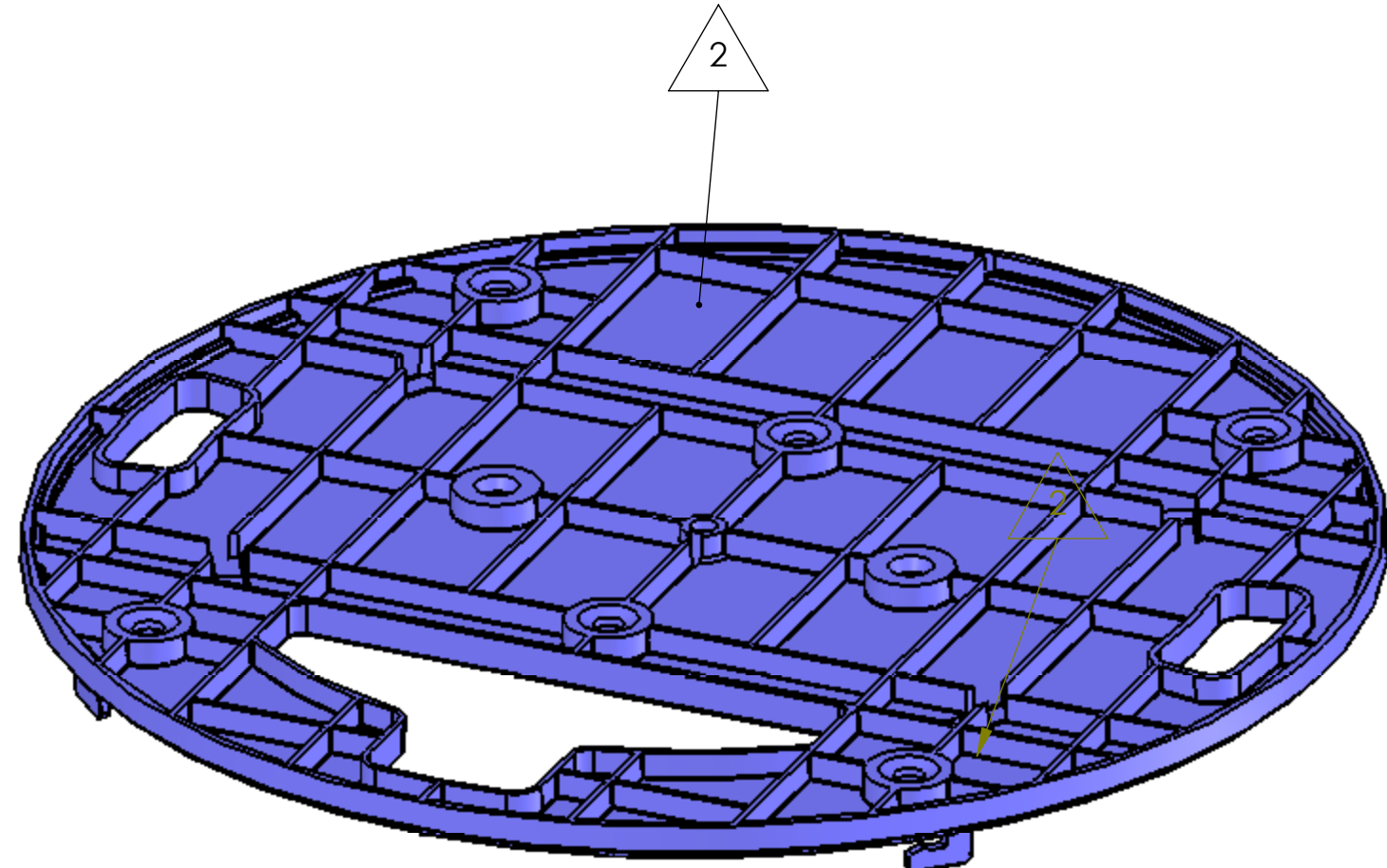

ITEM NO.	PartNo	DESCRIPTION	QTY.
1	170-0031-001	TLA, XN8, GENERIC	1
3	830-0124-001	LABEL, MFG., 1" X 2", BLANK, SERIAL NO.	1
4	830-0138-001	LABEL, WIFI, ABGN_DRAFT, 1.0 X 0.40625	1
5	830-0022-001	LABEL, UL, TEMPORARY	1
6	830-0146-001	LABEL, MODEL NUMBER, XN8	1

UNLESS OTHERWISE SPECIFIED:
 DIMENSIONS ARE IN INCHES
 TOLERANCES:
 FRACTIONAL: ± 1/4"
 ANGULAR: MACH ± 1/4"
 BEND ± 1/4"
 TWO PLACE DECIMAL ± .015
 THREE PLACE DECIMAL ± .005
 INTERPRET GEOMETRIC TOLERANCING PER ASME Y14.5M

NAME: I. LAITY
 DATE: 5/28/2008
 DRAWN: I. LAITY
 CHECKED: I. LAITY
 ENG APPR.:
 MFG APPR.:
 Q.A.:
 COMMENTS:

XIRRUS 370 North Westlake Blvd, Suite 200
 Westlake Village, California 91362

TITLE:
TLA, XN8, LABELED

SCALE: 1:3

SIZE DWG. NO. REV
C 185-0036-001 **A**
 PART NO. 180-0036-001

DO NOT SCALE DRAWING

SHEET 1 OF 1

PROPRIETARY AND CONFIDENTIAL
 THE INFORMATION CONTAINED IN THIS DRAWING IS THE SOLE PROPERTY OF XIRRUS. ANY REPRODUCTION IN PART OR AS A WHOLE WITHOUT THE WRITTEN PERMISSION OF XIRRUS IS PROHIBITED.