

*Electromagnetic Emissions Test Report
Application for Grant of Equipment Authorization
pursuant to
Industry Canada RSS-Gen Issue 2 / RSS 210 Issue 7
FCC Part 15 Subpart C
on the
Xirrus, Inc.
Transmitter
Model: XN16 and XN8*

UPN: 5428A-XN16 5428A-XN8
FCC ID: SK6XN16 SK6XN8

GRANTEE: Xirrus, Inc.
370 North Westlake Blvd., Suite 200
Westlake Village, CA 91362

TEST SITE: Elliott Laboratories, Inc.
684 W. Maude Ave
Sunnyvale, CA 94086

REPORT DATE: June 5, 2008
REISSUED: June 24, 2008

FINAL TEST DATE: May 14, May 19, May 21, May 22,
May 23, May 27, June 3 and June 4, 2008

AUTHORIZED SIGNATORY:



Mark Briggs
Principal Engineer



Testing Cert #2016-01

Elliott Laboratories, Inc. is accredited by the A2LA, certificate number 2016-01, to perform the test(s) listed in this report. This report shall not be reproduced, except in its entirety, without the written approval of Elliott Laboratories, Inc.

REVISION HISTORY

Rev #	Date	Comments	Modified By
1	6/18/08	Initial Release	Dave Guidotti
2	6/24/2008	Revised product description to detail power reduction for multi-radio operation in the 2.4GHz band when operating in 802.11b MIMO mode. Revised test data as follows: Clarified method used for PSD measurements Corrected resolution bandwidth used for 6dB bandwidth measurements (100kHz) Removed reference to frequency in the power table for multi-radio operation in a band Referenced the bandwidth settings for conducted spurious emissions measurements Clarified which EUT antenna was connected for the different radiated spurious measurements	Mark Briggs

TABLE OF CONTENTS

COVER PAGE.....1

REVISION HISTORY2

TABLE OF CONTENTS3

SCOPE.....5

OBJECTIVE.....5

STATEMENT OF COMPLIANCE.....6

TEST RESULTS SUMMARY7

 DIGITAL TRANSMISSION SYSTEMS (2400 – 2483.5MHZ)7

 DIGITAL TRANSMISSION SYSTEMS (5725 –5850 MHZ)8

 GENERAL REQUIREMENTS APPLICABLE TO ALL BANDS9

MEASUREMENT UNCERTAINTIES.....9

EQUIPMENT UNDER TEST (EUT) DETAILS.....10

 GENERAL.....10

 ANTENNA SYSTEM11

 ENCLOSURE.....11

 MODIFICATIONS.....11

 SUPPORT EQUIPMENT.....11

 EUT INTERFACE PORTS12

 EUT OPERATION.....12

TEST SITE.....13

 GENERAL INFORMATION.....13

 CONDUCTED EMISSIONS CONSIDERATIONS13

 RADIATED EMISSIONS CONSIDERATIONS13

MEASUREMENT INSTRUMENTATION14

 RECEIVER SYSTEM.....14

 INSTRUMENT CONTROL COMPUTER.....14

 LINE IMPEDANCE STABILIZATION NETWORK (LISN)14

 FILTERS/ATTENUATORS15

 ANTENNAS.....15

 ANTENNA MAST AND EQUIPMENT TURNTABLE.....15

 INSTRUMENT CALIBRATION.....15

TABLE OF CONTENTS (Continued)

TEST PROCEDURES16

EUT AND CABLE PLACEMENT 16

CONDUCTED EMISSIONS..... 16

RADIATED EMISSIONS 16

RADIATED EMISSIONS 17

BANDWIDTH MEASUREMENTS 21

SPECIFICATION LIMITS AND SAMPLE CALCULATIONS..... 21

GENERAL TRANSMITTER RADIATED EMISSIONS SPECIFICATION LIMITS 21

RECEIVER RADIATED SPURIOUS EMISSIONS SPECIFICATION LIMITS 22

OUTPUT POWER LIMITS – DIGITAL TRANSMISSION SYSTEMS..... 22

TRANSMIT MODE SPURIOUS RADIATED EMISSIONS LIMITS – FHSS AND DTS SYSTEMS..... 22

SAMPLE CALCULATIONS - CONDUCTED EMISSIONS 23

SAMPLE CALCULATIONS - RADIATED EMISSIONS 23

SAMPLE CALCULATIONS - FIELD STRENGTH TO EIRP CONVERSION 24

EXHIBIT 1: Test Equipment Calibration Data..... 1

EXHIBIT 2: Test Measurement Data..... 2

EXHIBIT 3: Photographs of Test Configurations..... 3

SCOPE

An electromagnetic emissions test has been performed on the Xirrus, Inc. models XN16 and XN8 pursuant to the following rules:

Industry Canada RSS-Gen Issue 2
RSS 210 Issue 7 "Low-power Licence-exempt Radiocommunication Devices (All Frequency Bands): Category I Equipment"
FCC Part 15 Subpart C

Conducted and radiated emissions data has been collected, reduced, and analyzed within this report in accordance with measurement guidelines set forth in the following reference standards and as outlined in Elliott Laboratories test procedures:

ANSI C63.4:2003
FCC DTS Measurement Procedure KDB558074, March 2005

The intentional radiator above has been tested in a simulated typical installation to demonstrate compliance with the relevant Industry Canada performance and procedural standards.

Final system data was gathered in a mode that tended to maximize emissions by varying orientation of EUT, orientation of power and I/O cabling, antenna search height, and antenna polarization.

Every practical effort was made to perform an impartial test using appropriate test equipment of known calibration. All pertinent factors have been applied to reach the determination of compliance.

The test results recorded herein are based on a single type test of the Xirrus, Inc. models XN16 and XN8 and therefore apply only to the tested sample. The sample was selected and prepared by Steve Smith of Xirrus, Inc.

OBJECTIVE

The primary objective of the manufacturer is compliance with the regulations outlined in the previous section.

Prior to marketing in the USA, all unlicensed transmitters and transceivers require certification. Receive-only devices operating between 30 MHz and 960 MHz are subject to either certification or a manufacturer's declaration of conformity, with all other receive-only devices exempt from the technical requirements.

Prior to marketing in Canada, Class I transmitters, receivers and transceivers require certification. Class II devices are required to meet the appropriate technical requirements but are exempt from certification requirements.

Certification is a procedure where the manufacturer submits test data and technical information to a certification body and receives a certificate or grant of equipment

authorization upon successful completion of the certification body's review of the submitted documents. Once the equipment authorization has been obtained, the label indicating compliance must be attached to all identical units, which are subsequently manufactured.

Maintenance of compliance is the responsibility of the manufacturer. Any modification of the product which may result in increased emissions should be checked to ensure compliance has been maintained (i.e., printed circuit board layout changes, different line filter, different power supply, harnessing or I/O cable changes, etc.).

STATEMENT OF COMPLIANCE

The tested sample of Xirrus, Inc. models XN16 and XN8 complied with the requirements of the following regulations:

- Industry Canada RSS-Gen Issue 2
- RSS 210 Issue 7 "Low-power Licence-exempt Radiocommunication Devices (All Frequency Bands): Category I Equipment"
- FCC Part 15 Subpart C

Maintenance of compliance is the responsibility of the manufacturer. Any modification of the product which may result in increased emissions should be checked to ensure compliance has been maintained (i.e., printed circuit board layout changes, different line filter, different power supply, harnessing or I/O cable changes, etc.).

TEST RESULTS SUMMARY**DIGITAL TRANSMISSION SYSTEMS (2400 – 2483.5MHz)**

FCC Rule Part	RSS Rule Part	Description	Measured Value / Comments	Limit / Requirement	Result
15.247(a)	RSS 210 A8.2	Digital Modulation	Systems uses OFDM / DSSS techniques	-	Complies
15.247 (a) (2)	RSS 210 A8.2 (1)	6dB Bandwidth	9.6 MHz	>500kHz	Complies
	RSP100	99% Bandwidth	b: 15.8 MHz g: 17.1 MHz n20: 18.3 MHz n40: 37.1 MHz	Information only	Complies
15.247 (b) (3)	RSS 210 A8.2 (4)	Output Power (multipoint systems)	b: 19.5/24.3 dBm b3x: 23.7/28.2dBm g:18.4/23.2dBm g3x:22.9/27.7dBm n20:23.0/27.7 dBm n40: 22.6dBm EIRP = 4.0 W ^{Note 1}	1 Watt, EIRP limited to 4 Watts.	Complies
15.247(d)	RSS 210 A8.2 (2)	Power Spectral Density	7.4 dBm / 3kHz	8dBm/3kHz	Complies
15.247(c)	RSS 210 A8.5	Antenna Port Spurious Emissions 30MHz – 25 GHz	All spurious more than 30dB below fundamental	< -30dBc ^{Note 2}	Complies
15.247(c) / 15.209	RSS 210 A8.5	Radiated Spurious Emissions 30MHz – 25 GHz	53.9dBμV/m (495.5μV/m) @ 2483.5MHz	15.207 in restricted bands, all others <-30dBc ^{Note 2}	Complies (-0.1dB)

Note 1: EIRP calculated using antenna gain of 3 dBi (7.77dBi for legacy 3x MIMO mode) for the highest EIRP multi-point system. The highest EIRP is with three radios operational, all using 802.11b 3x3 MIMO mode (3 chains per radio)

Note 2: Limit of -30dBc used because the power was measured using the UNII test procedure (maximum power averaged over a transmission burst) / RMS averaging over a time interval, as permitted under RSS 210 section A8.4(4).

Legacy mode MIMO operation is noted by b3x and g3x.

Where output powers are listed as two values, the first value is the output power on a single radio and the second value for 3 radios operational (this applies only to 20MHz channels).

DIGITAL TRANSMISSION SYSTEMS (5725 –5850 MHz)

FCC Rule Part	RSS Rule Part	Description	Measured Value / Comments	Limit / Requirement	Result
15.247(a)	RSS 210 A8.2	Digital Modulation	Systems uses OFDM / DSSS techniques	System must utilize a digital transmission technology	Complies
15.247 (a) (2)	RSS 210 A8.2 (1)	6dB Bandwidth	>16.3 MHz	>500kHz	Complies
	RSP100	99% Bandwidth	a: 17.4 MHz n20: 18.6 MHz n40: 37.0 MHz z	Information only	Complies
15.247 (b)	RSS 210 A8.2 (4)	Output Power (multipoint systems)	a: 15.1/22.1dBm a 2x: 17.5/24.5 dBm n20: 17.4/24.4 dBm n40: 17.2/20.2 dBm EIRP = 2.26 W ^{Note 1}	1 Watt, EIRP limited to 4 Watts.	Complies
15.247(d)	RSS 210 A8.2 (2)	Power Spectral Density	-1.8 dBm /3kHz	Maximum permitted is 8dBm/3kHz	Complies
15.247(c)	RSS 210 A8.5	Antenna Port Spurious Emissions – 30MHz – 40 GHz	All spurious more than 30dB below fundamental	< -30dBc ^{Note 2}	Complies
15.247(c) / 15.209	RSS 210 A8.5 Table 2, 3	Radiated Spurious Emissions 30MHz – 40 GHz	53.0dBμV/m @ 11576.3MHz	15.207 in restricted bands, all others <-30dBc ^{Note 2}	Complies (-1.0dB)

Note 1: EIRP calculated using antenna gain of 6 dBi (9dBi for legacy 2x MIMO mode) for the highest EIRP multi-point system. The highest EIRP is with 5 radios operational in the band using 802.11a 2x2 MIMO mode.

Note 2: Limit of -30dBc used because the power was measured using the UNII test procedure (maximum power averaged over a transmission burst) / RMS averaging over a time interval, as permitted under RSS 210 section A8.4(4).

Legacy mode MIMO operation is noted by a2x.

Where output powers are listed as two values, the first value is the output power on a single radio and the second value with the maximum number of radios operational in that mode (5 radios in 20Mhz modes or 2 radios in 40MHz modes).

GENERAL REQUIREMENTS APPLICABLE TO ALL BANDS

FCC Rule Part	RSS Rule part	Description	Measured Value / Comments	Limit / Requirement	Result (margin)
15.203	-	RF Connector	Internal antenna or reverse polarity TNC	Integral or unique connector	Complies
15.109	RSS GEN 7.2.3 Table 1	Receiver spurious emissions	44.2dB μ V/m @ 349.999MHz 47.2dB μ V/m @ 2291.7MHz	Table 1 of RSS GEN	Complies (- 1.8 dB)
15.207	RSS GEN Table 2	AC Conducted Emissions	42.8dB μ V @ 4.670MHz	Refer to standard	Complies (- 3.2 dB)
15.247 (b) (5) 15.407 (f)	RSS 102	RF Exposure Requirements	Refer to MPE calculations in Exhibit 11, RSS 102 declaration and User Manual statements.	Refer to OET 65, FCC Part 1 and RSS 102	Complies
	RSP 100 RSS GEN 7.1.5	User Manual	Refer to user manual for statements	Statement required regarding non-interference	Complies
	RSP 100 RSS GEN 7.1.5	User Manual	Refer to user manual for statements	Statement required regarding detachable antenna	Complies

MEASUREMENT UNCERTAINTIES

ISO/IEC 17025 requires that an estimate of the measurement uncertainties associated with the emissions test results be included in the report. The measurement uncertainties given below are based on a 95% confidence level and were calculated in accordance with UKAS document LAB 34.

Measurement Type	Frequency Range (MHz)	Calculated Uncertainty (dB)
Conducted Emissions	0.15 to 30	± 2.4
Radiated Emissions	0.015 to 30	± 3.0
Radiated Emissions	30 to 1000	± 3.6
Radiated Emissions	1000 to 40000	± 6.0

EQUIPMENT UNDER TEST (EUT) DETAILS**GENERAL**

The Xirrus, Inc. models XN16 and XN8 are multi-radio 802.11abgn Access Points which are designed to act as a hub for a wireless local area network (WLAN). The electrical rating of the device is 100/240Vac, 50/60Hz, 0.5-3A. They can be powered via an internal AC-DC adapter or via a PoE interface and dedicated PoE adapter (also sold with the device). Transmitter measurements were made with the device powered via PoE. Digital device emissions were measured with the device powered from the AC-DC adapter to cover both methods of powering the device.

The model XN16 contains 16 separate transceivers. The radio interfaces are provided via four identical circuit boards. Each of the boards has one 802.11bgn radio and three 802.11an radios. Each radio connects to an internal antenna with a gain of 3dBi for the bgn radio and 6dBi for the an radio. Three radio boards can connect to an external antenna via a reverse polarity TNC coaxial connector. The external antenna offered for use is a ceiling mount antenna, model CM2-2400/5500, with a nominal gain of 2.5dBi for all bands and is used to support single-chain legacy modes. The internal antennas support single-chain legacy modes and 3x3 MIMO modes for 2.4GHz, 2x2 MIMO for 5GHz.

The XN8 is identical to the XN16 except that the rf board is depopulated to leave only two transceivers, one that can operate as abgn in both 2.4GHz and 5GHz bands and the other that can operate only in the 5GHz bands as an 802.11an radio.

The individual radios operate independently i.e. they are not configured to transmit the same data but are designed to operate independent networks. The system firmware configures the radios such that no two radios can operate on overlapping channels. Additionally output power per radio may be adjusted to ensure the output power in the 5150 – 5250 MHz, 5250 – 5350 MHz and 5470 – 5725 MHz bands remains below the output power and EIRP limits per band when more than one radio is operating in a band. Power reductions for multi-radio operation in the 2.4 GHz is also implemented for 802.11b MIMO mode. For all other 2.4 GHz modes, and for operation in the 5GHz DTS band, power reduction is not required because the output power (30dBm) and EIRP (36dBm) limits are met when one or multiple radios are operating in those bands, given the restrictions for no two radios operating on overlapping channels. As there are only 3 non-overlapping 2.4GHz channels the fourth 802.11bgn radio is used in a receive-only mode to monitor for rogue APs and perform other security functions.

Normally, the EUT's would be ceiling mounted during operation. The EUT's were tested as both tabletop equipment and also tested with the EUT raised to a height of 1.5m above the ground plane. The highest transmitter emissions were found with the device elevated to a height of 1.5m above the ground plane and final measurements were made with the EUT at that height.

The sample was received on May 28, 2008 and tested on May 14, May 19, May 21, May 22, May 23, May 27, June 3 and June 4, 2008. The EUT consisted of the following component(s):

Manufacturer	Model	Description	Serial Number	FCC ID
Xirrus	XN16	802.11abgn access point	Prototype	SK6XN16
Xirrus	XN8	802.11abgn access point	Prototype	SK6XN8
Xirrus	PoE60U-560(G)-SS-R	Power Injector	P7450010A1	N/A

ANTENNA SYSTEM

The antennas are either integral to the device or connect to the EUT via a non-standard, reverse gender TNC connector, thereby meeting the requirements of FCC 15.203.

The antennas are either integral to the device or connect to the EUT via a non-standard, reverse gender TNC connector, thereby meeting the requirements of FCC 15.203.

ENCLOSURE

The enclosures for the XN16 and XN8 are identical. The enclosure is primarily constructed of plastic. It is circular with a diameter of 48 cm and a height of 10cm.

MODIFICATIONS

The EUT did not require modifications during testing in order to comply with emissions specifications.

SUPPORT EQUIPMENT

The following equipment was used as remote support equipment for emissions testing:

Manufacturer	Model	Description	Serial Number	FCC ID
IBM	R51	Laptop	99-V4543	DoC
Netgear	GS108	Switch	GS16152CB0354 47	DoC

EUT INTERFACE PORTS

The I/O cabling configuration during emissions testing was as follows:

Port	Connected To	Cable(s)		
		Description	Shielded or Unshielded	Length(m)
PoE adapter PoE IN	Switch	Cat 5	Unshielded	10.0
PoE adapter PoE Out	XN-x Data& Power IN	Cat 5	Unshielded	1.0
XN-x Data (To GIG 1/2) OUT	Ethernet 1	Cat 5	Unshielded	0.1
AC Power	PoE	3 wire	Unshielded	1.5

Note 1: The console port on the XN-16 was not connected during testing. This port is used for configuration and troubleshooting purposes only and is not intended to be connected during normal operation.

Note 2: The gigabit ethernet# 2, ethernet# 0 ports on the XN16 were not connected during testing. These ports were not exercised for this configuration.

EUT OPERATION

During AC conducted emissions all 16 radios were transmitting at max power on the following channels: 2412 MHz 802.11b, 2472 MHz 802.11g, 2437MHz 802.11n20, 5180 MHz 802.11a, 5320 MHz 802.11n20, 5500 MHz 802.11n40, 5700 MHz 802.11a, 5825 MHz 802.11n20, 5745 MHz 802.11n 20, 5600 MHz n20, 2412 MHz 802.11n20, 2462 MHz 802.11n20, 5510MHz n40, 5690 MHz 802.11n40, 5240 MHz 802.11a, 5260 MHz 802.11a, 5280 MHz 802.11n20.

During radiated emissions tests all 16 radios (8 for the XS-8) were in receive mode with all chains active on the following channels: 2437 MHz, 5200 MHz, 5280 MHz, 5600 MHz, 5785 MHz, 2412 MHz, 2472 MHz, 5180 MHz, 5320 MHz, 5500 MHz, 5700 MHz, 5785 MHz, 2462 MHz, 5240MHz,5260 MHz, 5540 MHz.

Transmit mode emissions were made with a single transceiver operational for band-edge radiated measurements and rf port measurements. The transmit chain(s) were transmitting continuously. Spurious measurements were made with one radio in 802.11a mode, one in 802.11n20 mode and one in 802.11n40 mode transmitting continuously on top and bottom and, where applicable, center channel.

Additionally a scan was made with all radios operational in different bands to verify that no inter-modulation products of significance were produced. The scan was made with a horn antenna close to the device. No signals were observed other than the harmonics of the individual signals measured during the spurious emissions tests.

Radiated emissions measurements made below 1GHz indicated that the emissions were all related to the digital device (i.e. they did not change when the radios were enabled or disabled, or when the operating frequencies of the radios were changed). Radiated emissions below 1GHz are therefore covered by the Part 15 Class B digital device verification test report.

TEST SITE

GENERAL INFORMATION

Final test measurements were taken on May 14, May 19, May 21, May 22, May 23, May 27, June 3 and June 4, 2008 at the Elliott Laboratories Open Area Test Site #1 & 2 located at 684 West Maude Avenue, Sunnyvale, California. Pursuant to section 2.948 of the FCC's Rules and section 3.3 of RSP-100, construction, calibration, and equipment data has been filed with the Commission.

ANSI C63.4:2003 recommends that ambient noise at the test site be at least 6 dB below the allowable limits. Ambient levels are below this requirement with the exception of predictable local TV, radio, and mobile communications traffic. The test site contains separate areas for radiated and conducted emissions testing. Considerable engineering effort has been expended to ensure that the facilities conform to all pertinent requirements of ANSI C63.4:2003.

CONDUCTED EMISSIONS CONSIDERATIONS

Conducted emissions testing is performed in conformance with ANSI C63.4:2003. Measurements are made with the EUT connected to the public power network through a nominal, standardized RF impedance, which is provided by a line impedance stabilization network, known as a LISN. A LISN is inserted in series with each current-carrying conductor in the EUT power cord.

RADIATED EMISSIONS CONSIDERATIONS

The FCC has determined that radiation measurements made in a shielded enclosure are not suitable for determining levels of radiated emissions. Radiated measurements are performed in an open field environment or in a semi-anechoic chamber. The test sites are maintained free of conductive objects within the CISPR defined elliptical area incorporated in ANSI C63.4:2003 guidelines and meet the Normalized Site Attenuation (NSA) requirements of ANSI C63.4:2003.

MEASUREMENT INSTRUMENTATION

RECEIVER SYSTEM

An EMI receiver as specified in CISPR 16-1 is used for emissions measurements. The receivers used can measure over the frequency range of 9 kHz up to 2000 MHz. These receivers allow both ease of measurement and high accuracy to be achieved. The receivers have Peak, Average, and CISPR (Quasi-peak) detectors built into their design so no external adapters are necessary. The receiver automatically sets the required bandwidth for the CISPR detector used during measurements. If the repetition frequency of the signal being measured is below 20Hz, peak measurements are made in lieu of Quasi-Peak measurements.

For measurements above the frequency range of the receivers, a spectrum analyzer is utilized because it provides visibility of the entire spectrum along with the precision and versatility required to support engineering analysis. Average measurements above 1000MHz are performed on the spectrum analyzer using the linear-average method with a resolution bandwidth of 1 MHz and a video bandwidth of 10 Hz, unless the signal is pulsed in which case the average (or video) bandwidth of the measuring instrument is reduced to onset of pulse desensitization and then increased.

INSTRUMENT CONTROL COMPUTER

The receivers utilize either a Rohde & Schwarz EZM Spectrum Monitor/Controller or contain an internal Spectrum Monitor/Controller to view and convert the receiver measurements to the field strength at an antenna or voltage developed at the LISN measurement port, which is then compared directly with the appropriate specification limit. This provides faster, more accurate readings by performing the conversions described under Sample Calculations within the Test Procedures section of this report. Results are printed in a graphic and/or tabular format, as appropriate. A personal computer is used to record all measurements made with the receivers.

The Spectrum Monitor provides a visual display of the signal being measured. In addition, the controller or a personal computer run automated data collection programs which control the receivers. This provides added accuracy since all site correction factors, such as cable loss and antenna factors are added automatically.

LINE IMPEDANCE STABILIZATION NETWORK (LISN)

Line conducted measurements utilize a fifty microhenry Line Impedance Stabilization Network as the monitoring point. The LISN used also contains a 250 uH CISPR adapter. This network provides for calibrated radio frequency noise measurements by the design of the internal low pass and high pass filters on the EUT and measurement ports, respectively.

FILTERS/ATTENUATORS

External filters and precision attenuators are often connected between the receiving antenna or LISN and the receiver. This eliminates saturation effects and non-linear operation due to high amplitude transient events.

ANTENNAS

A loop antenna is used below 30 MHz. For the measurement range 30 MHz to 1000 MHz either a combination of a biconical antenna and a log periodic or a bi-log antenna is used. Above 1000 MHz, horn antennas are used. The antenna calibration factors to convert the received voltage to an electric field strength are included with appropriate cable loss and amplifier gain factors to determine an overall site factor, which is then programmed into the test receivers or incorporated into the test software.

ANTENNA MAST AND EQUIPMENT TURNTABLE

The antennas used to measure the radiated electric field strength are mounted on a non-conductive antenna mast equipped with a motor-drive to vary the antenna height. Measurements below 30 MHz are made with the loop antenna at a fixed height of 1m above the ground plane.

ANSI C63.4:2003 specifies that the test height above ground for table mounted devices shall be 80 centimeters. Floor mounted equipment shall be placed on the ground plane if the device is normally used on a conductive floor or separated from the ground plane by insulating material from 3 to 12 mm if the device is normally used on a non-conductive floor. During radiated measurements, the EUT is positioned on a motorized turntable in conformance with this requirement.

INSTRUMENT CALIBRATION

All test equipment is regularly checked to ensure that performance is maintained in accordance with the manufacturer's specifications. All antennas are calibrated at regular intervals with respect to tuned half-wave dipoles. An exhibit of this report contains the list of test equipment used and calibration information.

TEST PROCEDURES

EUT AND CABLE PLACEMENT

The regulations require that interconnecting cables be connected to the available ports of the unit and that the placement of the unit and the attached cables simulate the worst case orientation that can be expected from a typical installation, so far as practicable. To this end, the position of the unit and associated cabling is varied within the guidelines of ANSI C63.4:2003, and the worst-case orientation is used for final measurements.

CONDUCTED EMISSIONS

Conducted emissions are measured at the plug end of the power cord supplied with the EUT. Excess power cord length is wrapped in a bundle between 30 and 40 centimeters in length near the center of the cord. Preliminary measurements are made to determine the highest amplitude emission relative to the specification limit for all the modes of operation. Placement of system components and varying of cable positions are performed in each mode. A final peak mode scan is then performed in the position and mode for which the highest emission was noted on all current carrying conductors of the power cord.

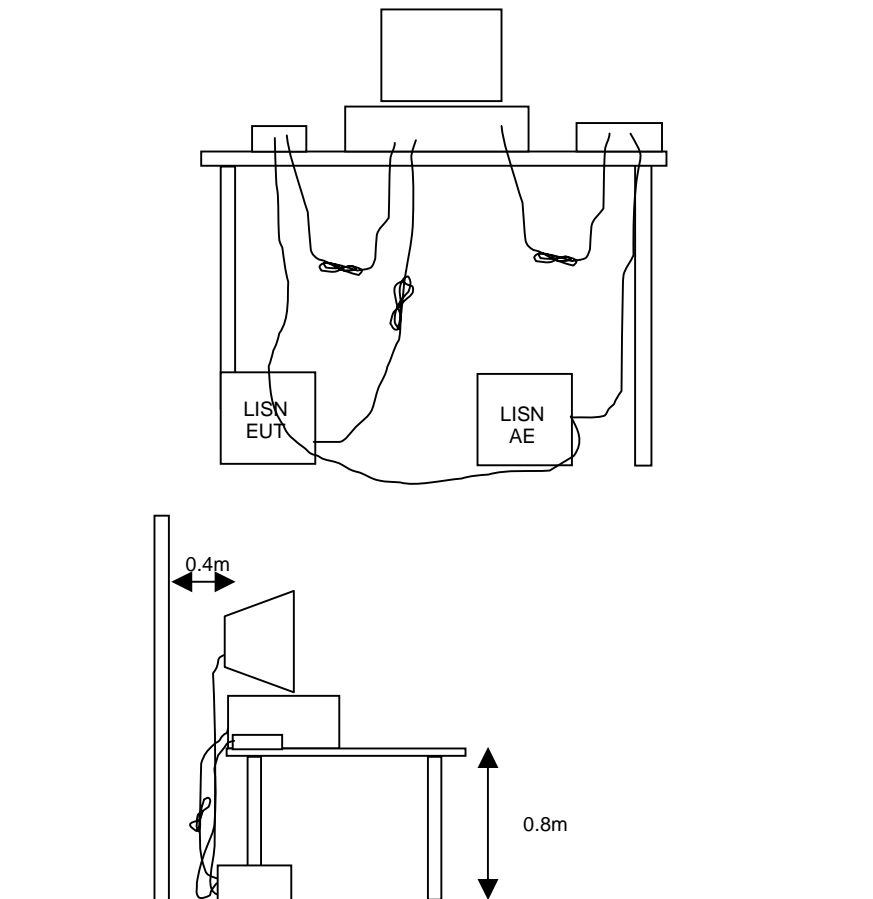

RADIATED EMISSIONS

A preliminary scan of the radiated emissions is performed in which all significant EUT frequencies are identified with the system in a nominal configuration. At least two scans are performed, one scan for each antenna polarization (horizontal and vertical; loop parallel and perpendicular to the EUT). During the preliminary scans, the EUT is rotated through 360°, the antenna height is varied (for measurements above 30 MHz) and cable positions are varied to determine the highest emission relative to the limit. Preliminary scans may be performed in a fully anechoic chamber for the purposes of identifying the frequencies of the highest emissions from the EUT.

A speaker is provided in the receiver to aid in discriminating between EUT and ambient emissions. Other methods used during the preliminary scan for EUT emissions involve scanning with near field magnetic loops, monitoring I/O cables with RF current clamps, and cycling power to the EUT.

Final maximization is a phase in which the highest amplitude emissions identified in the spectral search are viewed while the EUT azimuth angle is varied from 0 to 360 degrees relative to the receiving antenna. The azimuth, which results in the highest emission is then maintained while varying the antenna height from one to four meters (for measurements above 30 MHz, measurements below 30 MHz are made with the loop antenna at a fixed height of 1m). The result is the identification of the highest amplitude for each of the highest peaks. Each recorded level is corrected in the receiver using appropriate factors for cables, connectors, antennas, and preamplifier gain.

When testing above 18 GHz, the receive antenna is located at 1 meter from the EUT and the antenna height is restricted to a maximum of 2.5 meters.

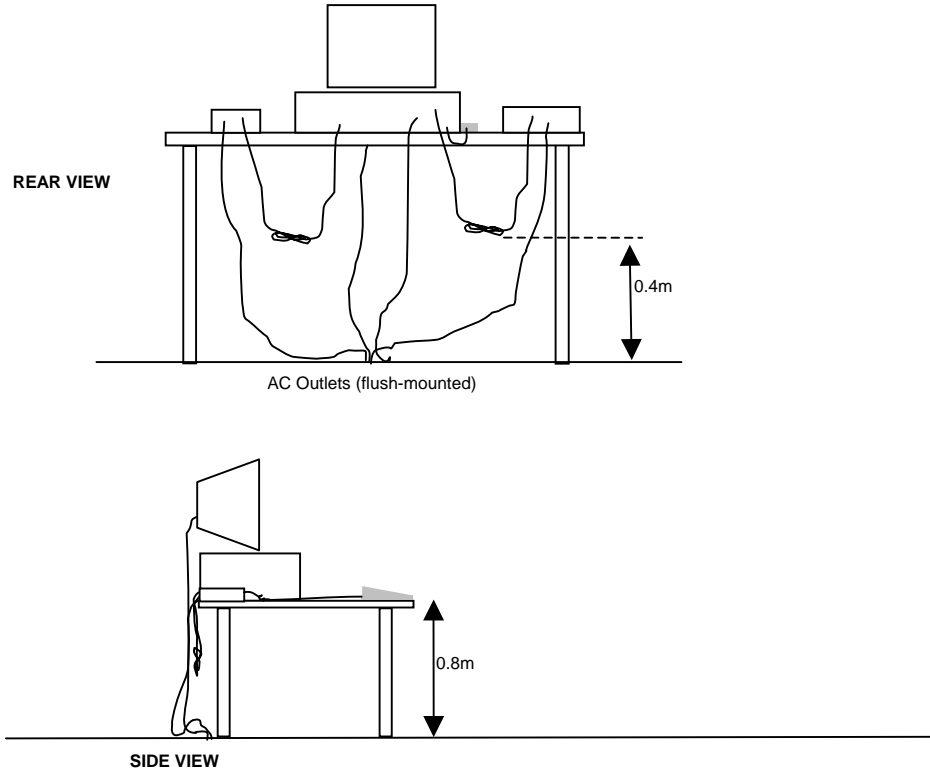

Typical Test Configuration for Radiated Field Strength Measurements

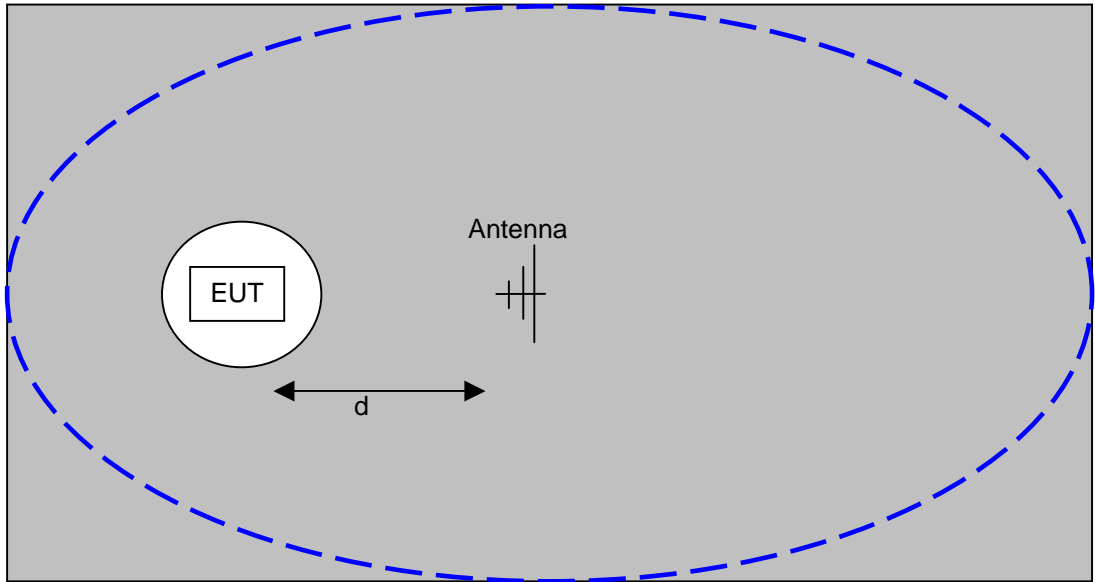

The ground plane extends beyond the ellipse defined in CISPR 16 / CISPR 22 / ANSI C63.4 and is large enough to accommodate test distances (d) of 3m and 10m. Refer to the test data tables for the actual measurement distance.

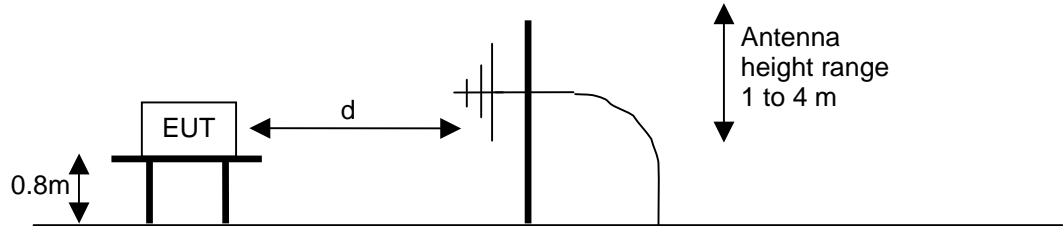

Test Configuration for Radiated Field Strength Measurements
OATS- Plan and Side Views

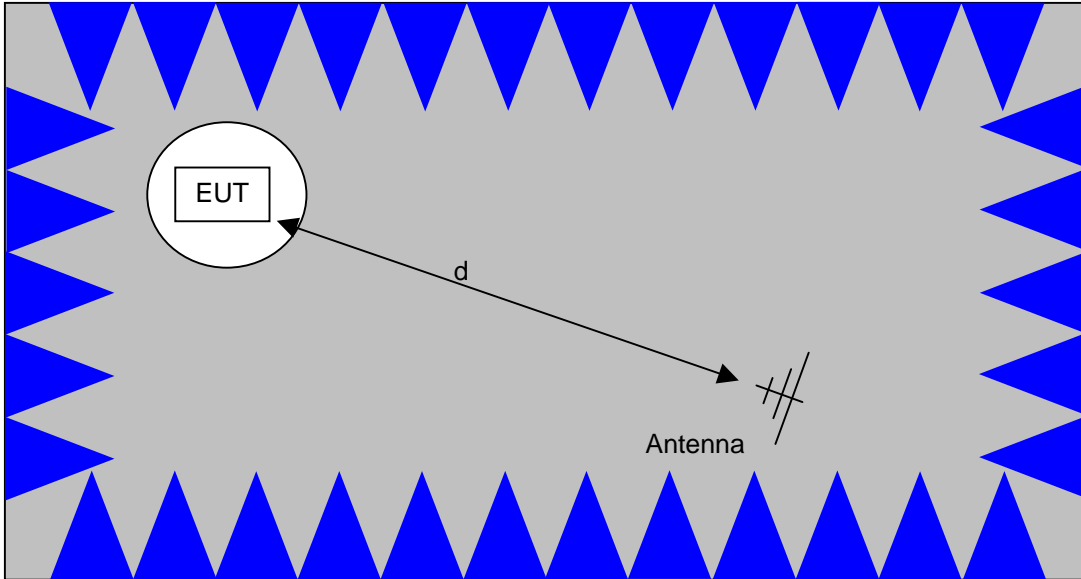

The anechoic materials on the walls and ceiling ensure compliance with the normalized site attenuation requirements of CISPR 16 / CISPR 22 / ANSI C63.4 for an alternate test site at the measurement distances used.

Floor-standing equipment is placed on the floor with insulating supports between the unit and the ground plane.

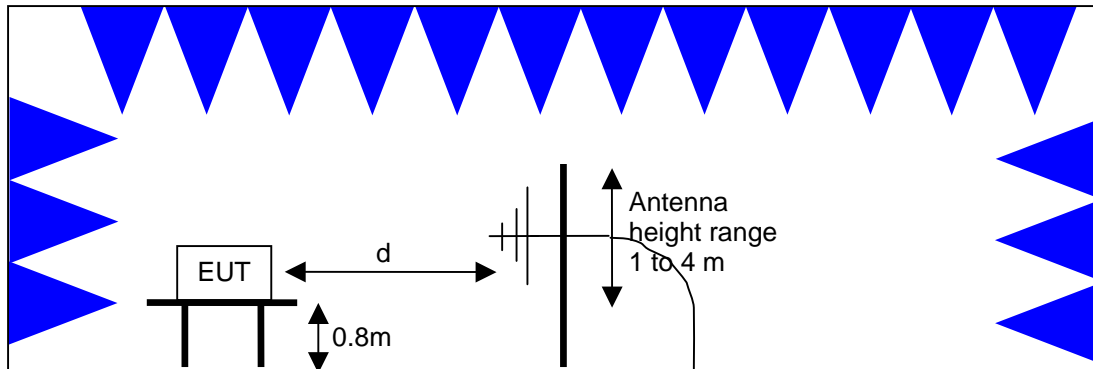

Test Configuration for Radiated Field Strength Measurements
Semi-Anechoic Chamber, Plan and Side Views

BANDWIDTH MEASUREMENTS

The 6dB, 20dB and/or 26dB signal bandwidth is measured in using the bandwidths recommended by ANSI C63.4. When required, the 99% bandwidth is measured using the methods detailed in RSS GEN.

SPECIFICATION LIMITS AND SAMPLE CALCULATIONS

The limits for conducted emissions are given in units of microvolts, and the limits for radiated emissions are given in units of microvolts per meter at a specified test distance. Data is measured in the logarithmic form of decibels relative to one microvolt, or dB microvolts (dBuV). For radiated emissions, the measured data is converted to the field strength at the antenna in dB microvolts per meter (dBuV/m). The results are then converted to the linear forms of uV and uV/m for comparison to published specifications.

For reference, converting the specification limits from linear to decibel form is accomplished by taking the base ten logarithm, then multiplying by 20. These limits in both linear and logarithmic form are as follows:

GENERAL TRANSMITTER RADIATED EMISSIONS SPECIFICATION LIMITS

The table below shows the limits for the spurious emissions from transmitters that fall in restricted bands¹ (with the exception of transmitters operating under FCC Part 15 Subpart D and RSS 210 Annex 9), the limits for all emissions from a low power device operating under the general rules of RSS 310 (tables 3 and 4), RSS 210 (table 2) and FCC Part 15 Subpart C section 15.209.

Frequency Range (MHz)	Limit (uV/m)	Limit (dBuV/m @ 3m)
0.009-0.490	$2400/F_{\text{KHz}} @ 300\text{m}$	$67.6-20*\log_{10}(F_{\text{KHz}}) @ 300\text{m}$
0.490-1.705	$24000/F_{\text{KHz}} @ 30\text{m}$	$87.6-20*\log_{10}(F_{\text{KHz}}) @ 30\text{m}$
1.705 to 30	30 @ 30m	29.5 @ 30m
30 to 88	100 @ 3m	40 @ 3m
88 to 216	150 @ 3m	43.5 @ 3m
216 to 960	200 @ 3m	46.0 @ 3m
Above 960	500 @ 3m	54.0 @ 3m

¹ The restricted bands are detailed in FCC 15.203, RSS 210 Table 1 and RSS 310 Table 2

RECEIVER RADIATED SPURIOUS EMISSIONS SPECIFICATION LIMITS

The table below shows the limits for the spurious emissions from receivers as detailed in FCC Part 15.109, RSS 210 Table 2, RSS GEN Table 1 and RSS 310 Table 3. Note that receivers operating outside of the frequency range 30 MHz – 960 MHz are exempt from the requirements of 15.109.

Frequency Range (MHz)	Limit (uV/m @ 3m)	Limit (dBuV/m @ 3m)
30 to 88	100	40
88 to 216	150	43.5
216 to 960	200	46.0
Above 960	500	54.0

OUTPUT POWER LIMITS – DIGITAL TRANSMISSION SYSTEMS

The table below shows the limits for output power and output power density. Where the signal bandwidth is less than 20 MHz the maximum output power is reduced to the power spectral density limit plus 10 times the log of the bandwidth (in MHz).

Operating Frequency (MHz)	Output Power	Power Spectral Density
902 – 928	1 Watt (30 dBm)	8 dBm/3kHz
2400 – 2483.5	1 Watt (30 dBm)	8 dBm/3kHz
5725 – 5850	1 Watt (30 dBm)	8 dBm/3kHz

The maximum permitted output power is reduced by 1dB for every dB the antenna gain exceeds 6dBi. Fixed point-to-point applications using the 5725 – 5850 MHz band are not subject to this restriction.

TRANSMIT MODE SPURIOUS RADIATED EMISSIONS LIMITS – FHSS and DTS SYSTEMS

The limits for unwanted (spurious) emissions from the transmitter falling in the restricted bands are those specified in the general limits sections of FCC Part 15 and RSS 210. All other unwanted (spurious) emissions shall be at least 20dB below the level of the highest in-band signal level (30dB if the power is measured using the sample detector/power averaging method).

SAMPLE CALCULATIONS - CONDUCTED EMISSIONS

Receiver readings are compared directly to the conducted emissions specification limit (decibel form) as follows:

$$R_r - S = M$$

where:

R_r = Receiver Reading in dBuV

S = Specification Limit in dBuV

M = Margin to Specification in +/- dB

SAMPLE CALCULATIONS - RADIATED EMISSIONS

Receiver readings are compared directly to the specification limit (decibel form). The receiver internally corrects for cable loss, preamplifier gain, and antenna factor. The calculations are in the reverse direction of the actual signal flow, thus cable loss is added and the amplifier gain is subtracted. The Antenna Factor converts the voltage at the antenna coaxial connector to the field strength at the antenna elements.

A distance factor, when used for electric field measurements above 30MHz, is calculated by using the following formula:

$$F_d = 20 * \text{LOG}_{10} (D_m/D_s)$$

where:

F_d = Distance Factor in dB

D_m = Measurement Distance in meters

D_s = Specification Distance in meters

For electric field measurements below 30MHz the extrapolation factor is either determined by making measurements at multiple distances or a theoretical value is calculated using the formula:

$$F_d = 40 * \text{LOG}_{10} (D_m/D_s)$$

Measurement Distance is the distance at which the measurements were taken and Specification Distance is the distance at which the specification limits are based. The antenna factor converts the voltage at the antenna coaxial connector to the field strength at the antenna elements.

The margin of a given emission peak relative to the limit is calculated as follows:

$$R_c = R_r + F_d$$

and

$$M = R_c - L_s$$

where:

$$R_r = \text{Receiver Reading in dBuV/m}$$

$$F_d = \text{Distance Factor in dB}$$

$$R_c = \text{Corrected Reading in dBuV/m}$$

$$L_s = \text{Specification Limit in dBuV/m}$$

$$M = \text{Margin in dB Relative to Spec}$$

SAMPLE CALCULATIONS - FIELD STRENGTH TO EIRP CONVERSION

Where the radiated electric field strength is expressed in terms of the equivalent isotropic radiated power (eirp), or where a field strength measurement of output power is made in lieu of a direct measurement, the following formula is used to convert between eirp and field strength at a distance of 3m from the equipment under test:

$$E = \frac{1000000 \sqrt{30 P}}{3} \quad \text{microvolts per meter}$$

where P is the eirp (Watts)

EXHIBIT 1: Test Equipment Calibration Data

3 Pages

Radio Antenna Port (Power and Spurious Emissions), 03-Jun-08

Engineer: Mehran Birgani

<u>Manufacturer</u>	<u>Description</u>	<u>Model #</u>	<u>Asset #</u>	<u>Cal Due</u>
Hewlett Packard	Spectrum Analyzer 30 Hz -40 GHz, SV (SA40) Red	8564E (84125C)	1148	24-Aug-08

Radio Antenna Port (Power and Spurious Emissions), 04-Jun-08

Engineer: Mehran Birgani

<u>Manufacturer</u>	<u>Description</u>	<u>Model #</u>	<u>Asset #</u>	<u>Cal Due</u>
Hewlett Packard	Spectrum Analyzer 30 Hz -40 GHz, SV (SA40) Red	8564E (84125C)	1148	24-Aug-08

Radio Antenna Port (Power and Spurious Emissions), 04-Jun-08

Engineer: Suhaila Khushzad

<u>Manufacturer</u>	<u>Description</u>	<u>Model #</u>	<u>Asset #</u>	<u>Cal Due</u>
Hewlett Packard	SpecAn 9 kHz - 40 GHz, (SA40)	8564E	CH5273	20-Jul-08

Radio Antenna Port (Power and Spurious Emissions), 09-Jun-08

Engineer: Mehran Birgani

<u>Manufacturer</u>	<u>Description</u>	<u>Model #</u>	<u>Asset #</u>	<u>Cal Due</u>
Hewlett Packard	Spectrum Analyzer 30 Hz -40 GHz, SV (SA40) Red	8564E (84125C)	1148	24-Aug-08

Radiated Emissions, 30 - 26,000 MHz, 14-May-08**Engineer: Mehran Birgani**

<u>Manufacturer</u>	<u>Description</u>	<u>Model #</u>	<u>Asset #</u>	<u>Cal Due</u>
EMCO	Antenna, Horn, 1-18GHz	3115	868	10-Jun-10
Hewlett Packard	Microwave Preamplifier, 1-26.5GHz	8449B	870	08-Nov-08
Hewlett Packard	High Pass filter, 3.5 GHz (Red System)	P/N 84300-80038 (84125C)	1403	24-Aug-08
Hewlett Packard	SpecAn 9 kHz - 40 GHz, (SA40)	8564E	CH5273	20-Jul-08

Radiated Emissions, 30 - 26,500 MHz, 21-May-08**Engineer: Mehran Birgani**

<u>Manufacturer</u>	<u>Description</u>	<u>Model #</u>	<u>Asset #</u>	<u>Cal Due</u>
Hewlett Packard	Microwave Preamplifier, 1-26.5GHz	8449B	870	08-Nov-08
Hewlett Packard	Spectrum Analyzer 30 Hz -40 GHz, SV (SA40) Red	8564E (84125C)	1148	24-Aug-08
Hewlett Packard	High Pass filter, 3.5 GHz	P/N 84300-80038	1157	15-Oct-08
EMCO	Antenna, Horn, 1-18 GHz (SA40-Blu)	3115	1386	11-Jul-08

Radiated Emissions, 30 - 18,000 MHz, 22-May-08**Engineer: Mehran Birgani**

<u>Manufacturer</u>	<u>Description</u>	<u>Model #</u>	<u>Asset #</u>	<u>Cal Due</u>
EMCO	Antenna, Horn, 1-18 GHz	3115	786	07-Dec-08
Hewlett Packard	EMC Spectrum Analyzer, 9 KHz - 22 GHz	8593EM	1319	18-Jul-08
Miteq	Preamplifier, 1-18 GHz	AFS44	1540	12-Nov-08

, 16-May-08

Engineer: Mehran Birgani

<u>Manufacturer</u>	<u>Description</u>	<u>Model #</u>	<u>Asset #</u>	<u>Cal Due</u>
Elliott Laboratories	Biconical Antenna, 30-300 MHz	EL30.300	54	26-Mar-09
EMCO	Log Periodic Antenna, 0.3-1 GHz	3146A	364	13-Dec-08
EMCO	Antenna, Horn, 1-18 GHz	3115	487	24-May-08
Hewlett Packard	Microwave Preamplifier, 1-26.5GHz	8449B	870	08-Nov-08
Hewlett Packard	EMC Spectrum Analyzer, 9 KHz-26.5 GHz	8593EM	1141	29-Nov-08
Hewlett Packard	Preamplifier, 100 kHz - 1.3 GHz	8447D OPT 010	1826	25-May-08

Radiated Emissions, 30 - 40,000 MHz, 20-May-08

Engineer: Mehran Birgani

<u>Manufacturer</u>	<u>Description</u>	<u>Model #</u>	<u>Asset #</u>	<u>Cal Due</u>
Elliott Laboratories	Biconical Antenna, 30-300 MHz	EL30.300	54	26-Mar-09
EMCO	Log Periodic Antenna, 0.3-1 GHz	3146A	364	13-Dec-08
Hewlett Packard	Microwave Preamplifier, 1-26.5GHz	8449B	870	08-Nov-08
Hewlett Packard	Spectrum Analyzer 30 Hz -40 GHz, SV (SA40) Red	8564E (84125C)	1148	24-Aug-08
EMCO	Antenna, Horn, 18-26.5 GHz (SA40-Red)	3160-09 (84125C)	1150	05-Nov-08
EMCO	Antenna, Horn, 26.5-40 GHz (SA40-Red)	3160-10 (84125C)	1151	05-Nov-08
EMCO	Antenna, Horn, 1-18 GHz	3117	1662	11-Apr-10
Micro-Tronics	Band Reject Filter, 5150-5350 MHz	BRC50703-02	1680	29-May-08
Micro-Tronics	Band Reject Filter, 5470-5725 MHz	BRC50704-02	1681	29-May-08
Micro-Tronics	Band Reject Filter, 5725-5875 MHz	BRC50705-02	1682	29-May-08
Hewlett Packard	Preamplifier, 100 kHz - 1.3 GHz	8447D OPT 010	1826	25-May-08

Radiated Emissions, 30 - 5,000 MHz, 23-May-08

Engineer: Mehran Birgani

<u>Manufacturer</u>	<u>Description</u>	<u>Model #</u>	<u>Asset #</u>	<u>Cal Due</u>
Elliott Laboratories	Biconical Antenna, 30-300 MHz	EL30.300	54	26-Mar-09
EMCO	Log Periodic Antenna, 0.3-1 GHz	3146A	364	13-Dec-08
Hewlett Packard	Microwave Preamplifier, 1-26.5GHz	8449B	870	08-Nov-08
Hewlett Packard	EMC Spectrum Analyzer, 9 KHz-26.5 GHz	8593EM	1141	29-Nov-08
EMCO	Antenna, Horn, 1-18 GHz	3117	1662	11-Apr-10
Hewlett Packard	Preamplifier, 100 kHz - 1.3 GHz	8447D OPT 010	1826	25-May-08

Radiated Emissions, 30 - 5,000 MHz, 28-May-08

Engineer: Mehran Birgani

<u>Manufacturer</u>	<u>Description</u>	<u>Model #</u>	<u>Asset #</u>	<u>Cal Due</u>
Hewlett Packard	Microwave Preamplifier, 1-26.5GHz	8449B	263	16-Jun-08
EMCO	Antenna, Horn, 1-18 GHz	3115	487	24-Jun-08
Hewlett Packard	EMC Spectrum Analyzer, 9 kHz - 6.5 GHz	8595EM	787	19-Feb-09
Rohde & Schwarz	Test Receiver, 0.009-2750 MHz	ESN	1332	29-Jan-09
EMCO	Log Periodic Antenna, 0.2-2 GHz	3148	1347	17-Jan-09
EMCO	Biconical Antenna, 30-300 MHz	3110B	1497	03-Jul-08

Radiated Emissions, 30 - 18,000 MHz, 30-May-08

Engineer: Suhaila Khushzad

<u>Manufacturer</u>	<u>Description</u>	<u>Model #</u>	<u>Asset #</u>	<u>Cal Due</u>
EMCO	Biconical Antenna, 30-300 MHz	3110B	801	19-Sep-09
Hewlett Packard	Microwave Preamplifier, 1-26.5GHz	8449B	870	08-Nov-08
Rohde & Schwarz	Test Receiver, 9 kHz-2750 MHz	ESCS 30	1337	21-Sep-08
EMCO	Antenna, Horn, 1-18 GHz (SA40-Blu)	3115	1386	11-Jul-08

Conducted Emissions - AC Power and Telecommunications Ports, 03-Jun-08

Engineer: Chris Groat

<u>Manufacturer</u>	<u>Description</u>	<u>Model #</u>	<u>Asset #</u>	<u>Cal Due</u>
Elliott Laboratories	LISN, FCC / CISPR	LISN-3, OATS	304	18-Jul-08
Rohde & Schwarz	Test Receiver, 9 kHz-2750 MHz	ESCS 30	1337	21-Sep-08
Rohde & Schwarz	Pulse Limiter	ESH3 Z2	1398	12-Feb-09
Fischer Custom Comm.	FCC-TLISN-T8-02 (Includes 1907)	FCC-TLISN-T8-02	1906	05-Jul-08
Hewlett Packard	SpecAn 9 kHz - 40 GHz, (SA40)	8564E	CH5273	20-Jul-08

EXHIBIT 2: Test Measurement Data

T71643 – RF Port Measurements (Power, PSD etc)	130 Pages
T71641 – Transmitter Radiated Emissions	45 Pages
T71645 – AC Conducted Emissions, Receiver and digital device radiated emissions	18 Pages



EMC Test Data

Client:	Xirrus	Job Number:	J71456
Model:	XN-16 and XN-8	T-Log Number:	T71643
		Account Manager:	Susan Pelzl
Contact:	Steve Smith		Mark Briggs
Emissions Standard(s):	-	Class:	-
Immunity Standard(s):	-	Environment:	-

EMC Test Data

For The

Xirrus

Model

XN-16 and XN-8

Date of Last Test: 6/6/2008

Client: Xirrus

Job Number: J71456

Model: XN-16 and XN-8

T-Log Number: T71643

Account Manager: Susan Pelzi

RSS 210 and FCC 15.247 Power Measurement Summary

2.4GHz Band

There are three non-overlapping 20MHz channels and no 40MHz non-overlapping channels. The power measurements below cover the cases where there is only one radio operational in the 2.4GHz band and where there are the maximum number of radios (3x20MHz channel or 1x40MHz channel) operating in the band. For the 802.11b mode the output power per radio has to be reduced from the maximum single-radio power. For all other modes the single radio power level can be used regardless of the number of radios operational in the band.

802.11b - single chain

Power Setting ²	Frequency (MHz)	Output Power		Antenna Gain (dBi)	EIRP ^{Note 2}	
		(dBm) ¹	mW		dBm	W
18.0	2412	18.3	67.6	3.0	21.3	0.135
20.0	2437	19.5	89.1	3.0	22.5	0.178
18.5	2462	17.4	55.0	3.0	20.4	0.110
3 radios in 802.11b mode:		24.3	267.4	4.0	28.3	0.672

802.11b - triple chain (EIRP assumes coherency between chains, effective antenna gain is x3)

Frequency (MHz)	Software Setting	Output Power (dBm)				Antenna Gain (dBi)	EIRP ^{Note 2}	
		A	B	C	Total		dBm	W
2412 MHz	17.5	17.2	15.8	15.3	20.9	7.77	28.7	0.744
2437 MHz	20.0	19.4	18.3	18.9	23.7	7.77	31.4	1.390
2462 MHz	17.5	16.4	15.7	16.7	21.1	7.77	28.8	0.763

Highest power setting with two channels in use, MIMO Mode:

-	20.0	19.4	18.3	18.9	23.7	7.77	31.4	1.390
Output power with three radios operating in 802.11b MIMO mode:					26.7	7.77	34.4	2.781

Highest power setting with three channels in use, MIMO Mode:

-	19.5	18.9	18.2	18.9	23.5	7.77	31.2	1.324
Output power with three radios operating in 802.11b MIMO mode:					28.2	7.77	36.0	3.973

802.11g - single chain

Power Setting ²	Frequency (MHz)	Output Power		Antenna Gain (dBi)	EIRP ^{Note 2}	
		(dBm) ¹	mW		dBm	W
13.5	2412	12.3	17.0	3.0	15.3	0.034
20.0	2437	18.4	69.2	3.0	21.4	0.138
13.5	2462	11.6	14.5	3.0	14.6	0.029
3 radios in 802.11g mode:		23.2	207.5	4.0	27.2	0.521

802.11g - triple chain (EIRP assumes coherency between chains, effective antenna gain is x3)

Frequency (MHz)	Software Setting	Output Power (dBm)				Antenna Gain (dBi)	EIRP ^{Note 2}	
		A	B	C	Total		dBm	W
2412 MHz	14.5	13.3	12.5	11.4	17.2	7.77	25.0	0.317
2437 MHz	20.0	18.6	17.1	18.5	22.9	7.77	30.7	1.164
2462 MHz	13.5	11.6	11.2	11.9	16.3	7.77	24.1	0.258

Highest power setting with three channels in use, MIMO Mode:

2437 MHz	20.0	18.6	17.1	18.5	22.9	7.77	30.7	1.164
Output power with three radios operating in 802.11g MIMO mode:					27.66	7.77	35.4	3.493

Client: Xirrus	Job Number: J71456
Model: XN-16 and XN-8	T-Log Number: T71643
	Account Manager: Susan Pelzi

802.11n 20MHz - triple chain (EIRP assumes no coherency between chains, effective antenna gain is x1)

Frequency (MHz)	Software Setting	Output Power (dBm)				Antenna Gain (dBi)	EIRP ^{Note 2}	
		A	B	C	Total		dBm	W
2412 MHz	13.0	11.7	10.8	9.7	15.6	3.0	18.6	0.072
2437 MHz	20.0	18.4	17.5	18.6	23.0	3.0	26.0	0.395
2462 MHz	9.5	8.2	6.8	8.1	12.5	3.0	15.5	0.036
Output power with three radios operating in 802.11n20 MIMO mode:					27.7	3.0	30.7	1.184

802.11n 40MHz - triple chain (EIRP assumes no coherency between chains, effective antenna gain is x1)

Frequency (MHz)	Software Setting	Output Power (dBm)				Antenna Gain (dBi)	EIRP ^{Note 2}	
		A	B	C	Total		dBm	W
2422 MHz	8.0	7.2	6.0	6.2	11.3	3.0	14.3	0.027
2437 MHz	20.0	18.4	17.2	17.7	22.6	3.0	25.6	0.360
2452 MHz	9.0	7.7	6.7	7.7	12.2	3.0	15.2	0.033

5.7GHz Band

There are five non-overlapping 20MHz channels and three non-overlapping 40MHz channels in this band. The power measurements below cover the cases where there is only one radio operational in the 5.7GHz band and where there are the maximum number of radios (5x20MHz channel or 3x40MHz channel) operating in the band. For all modes the single radio power level can be used regardless of the number of radios operational in the band.

802.11a - single chain

Power Setting ²	Frequency (MHz)	Output Power		Antenna Gain (dBi)	EIRP ^{Note 2}	
		(dBm) ¹	mW		dBm	W
17	5745	14.6	28.8	6.0	20.6	0.115
17	5785	14.6	28.8	6.0	20.6	0.115
17	5825	15.1	32.5	6.0	21.1	0.129
5 radios in 802.11a mode:		22.1	162.5	6.0	28.1	0.647

802.11a - dual chain (EIRP assumes coherency between chains, effective antenna gain is x2)

Frequency (MHz)	Software Setting	Output Power (dBm)				Antenna Gain (dBi)	EIRP ^{Note 2}	
		A	B	C	Total		dBm	W
5745 MHz	17.0	14.7		13.7	17.2	9.0	26.2	0.421
5785 MHz	17.0	14.8		13.4	17.2	9.0	26.2	0.414
5825 MHz	17.0	15.3		13.6	17.5	9.0	26.5	0.451
Output power with five radios operating in 802.11a MIMO mode:					24.5	9.0	33.5	2.256

802.11n 20MHz - triple chain (EIRP assumes no coherency between chains, effective antenna gain is x1)

Frequency (MHz)	Software Setting	Output Power (dBm)				Antenna Gain (dBi)	EIRP ^{Note 2}	
		A	B	C	Total		dBm	W
5745 MHz	17.0	14.7		13.7	17.2	6.0	23.2	0.211
5785 MHz	17.0	14.6		13.5	17.1	6.0	23.1	0.204
5825 MHz	17.0	15		13.6	17.4	6.0	23.4	0.217
Output power with five radios operating in 802.11n20 MIMO mode:					24.4	6.0	30.4	1.085

802.11n 40MHz - triple chain (EIRP assumes no coherency between chains, effective antenna gain is x1)

Frequency (MHz)	Software Setting	Output Power (dBm)				Antenna Gain (dBi)	EIRP ^{Note 2}	
		A	B	C	Total		dBm	W
5755 MHz	17.0	14.5		13.8	17.2	6.0	23.2	0.208
5795	17.0	11.8		13.5	15.7	6.0	21.7	0.149
Output power with two radios operating in 802.11n40 MIMO mode:					20.2	6.0	26.2	0.415

Client: Xirrus	Job Number: J71456
Model: XN-16 and XN-8	T-Log Number: T71643
	Account Manager: Susan Pezli
Contact: Steve Smith	
Standard: -	Class: N/A

RSS 210 and FCC 15.247 (DTS) Antenna Port Measurements Power, PSD, Bandwidth and Spurious Emissions

Test Specific Details

Objective: The objective of this test session is to perform final qualification testing of the EUT with respect to the specification listed above.

Date of Test: 6/3/2008
 Test Engineer: Mehran Birgani
 Test Location: Chamber #2

Config. Used: -
 Config Change: -
 EUT Voltage: POE

General Test Configuration

The EUT was connected to the spectrum analyzer or power meter via a suitable attenuator. All measurements were made on a single chain.

All measurements have been corrected to allow for the external attenuators used.

Ambient Conditions:

Temperature: 16 °C
 Rel. Humidity: 39 %

Summary of Results

Run #	Test Performed	Limit	Pass / Fail	Result / Margin
1	Output Power	15.247(b)	Pass	802.11b: 19.5 dBm 802.11g: 18.4 dBm
2	PSD	15.247(d)	Pass	802.11b: -2.3 dBm/3kHz 802.11g: 1.1 dBm/3kHz
3	Minimum 6dB Bandwidth	15.247(a)	Pass	802.11b: 10.0 MHz 802.11g: 16.3 MHz
3	99% Bandwidth	RSS GEN	Pass	802.11b: 15.8 MHz 802.11g: 17.1 MHz
4	Spurious emissions	15.247(b)	Pass	All signal were more than 30dB below the fundamental

Modifications Made During Testing

No modifications were made to the EUT during testing

Deviations From The Standard

No deviations were made from the requirements of the standard.

Client: Xirrus	Job Number: J71456
Model: XN-16 and XN-8	T-Log Number: T71643
	Account Manager: Susan Pezli
Contact: Steve Smith	
Standard: -	Class: N/A

Run #1: Output Power
802.11b - Single Radio In the Band

Power Setting ²	Frequency (MHz)	Output Power		Antenna Gain (dBi)	Result	EIRP ^{Note 2}	
		(dBm) ¹	mW			dBm	W
18.0	2412	18.3	67.6	3.0	Pass	21.3	0.135
20.0	2437	19.5	89.1	3.0	Pass	22.5	0.178
18.5	2462	17.4	55.0	3.0	Pass	20.4	0.110

802.11g - Single radio in the band

Power Setting ²	Frequency (MHz)	Output Power		Antenna Gain (dBi)	Result	EIRP ^{Note 2}	
		(dBm) ¹	mW			dBm	W
13.5	2412	12.3	17.0	3.0	Pass	15.3	0.034
20.0	2437	18.4	69.2	3.0	Pass	21.4	0.138
13.5	2462	11.6	14.5	3.0	Pass	14.6	0.029

802.11b - Three radios on non-overlapping channels, note 3

Power Setting ²	Frequency (MHz)	Output Power per radio		Total Power		Antenna Gain (dBi)	Result	EIRP ^{Note 2}	
		(dBm) ¹	mW	dBm	mW			dBm	W
20.0	2437	19.5	89.1	24.3	267.4	3.0	Pass	22.5	0.178

802.11g - Three radios on non-overlapping channels radio in the band, note 3

Power Setting ²	Frequency (MHz)	Output Power per radio		Total Power		Antenna Gain (dBi)	Result	EIRP ^{Note 2}	
		(dBm) ¹	mW	dBm	mW			dBm	W
20.0	2437	18.4	69.2	23.2	207.5	3.0	Pass	21.4	0.138

Note 1:	Output power measured using a spectrum analyzer (see plots below): RBW=1MHz, VB=3 MHz, sample detector, power averaging on (transmitted signal was continuous) and power integration over 50 MHz. Spurious limit is -30dBc because this method was used. The output power limit is 30dBm.
Note 2:	Power setting - the software power setting used during testing, included for reference only.
Note 3:	The device has multiple radios, but the software limits operation in any band to ensure only non-overlapping channels are used (no two radios can operate on the same channel or on overlapping channels). In the 2412 - 2462 MHz band there can be a maximum of 3 radios active. The calculated total power (obtained by multiplying the output power on a single radio by the number of radios that can be operating in the band) demonstrates that, with 3 radios active, the total output power still complies with the limit.

Client: Xirus	Job Number: J71456
Model: XN-16 and XN-8	T-Log Number: T71643
Contact: Steve Smith	Account Manager: Susan Pezli
Standard: -	Class: N/A

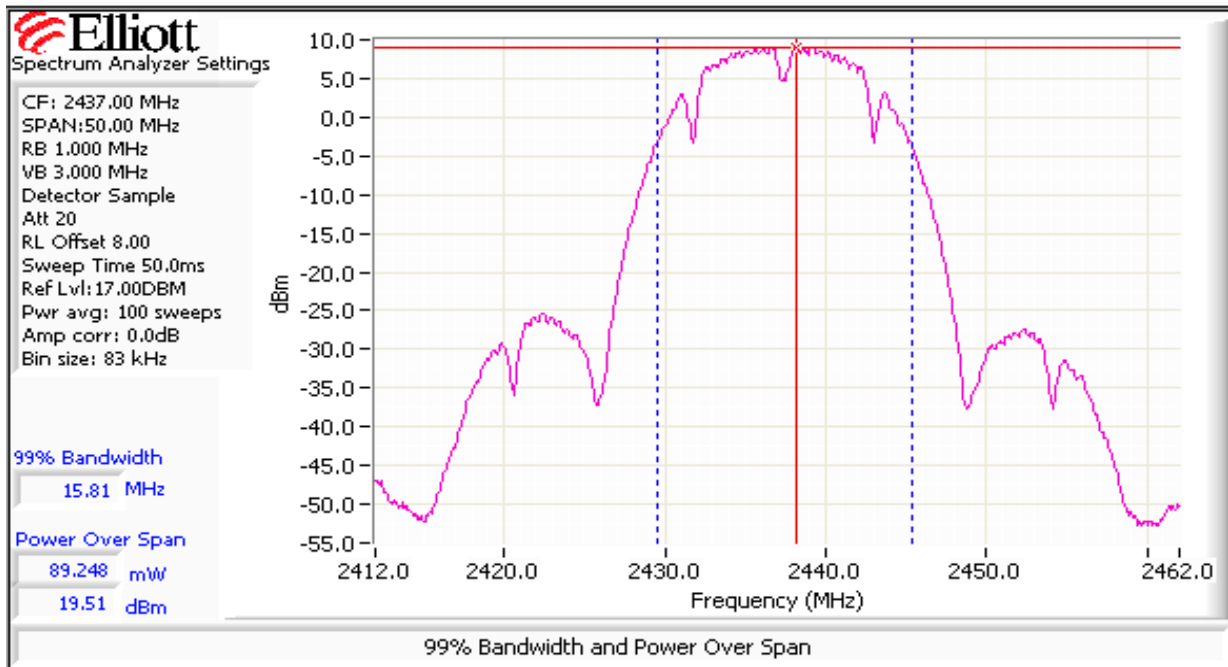
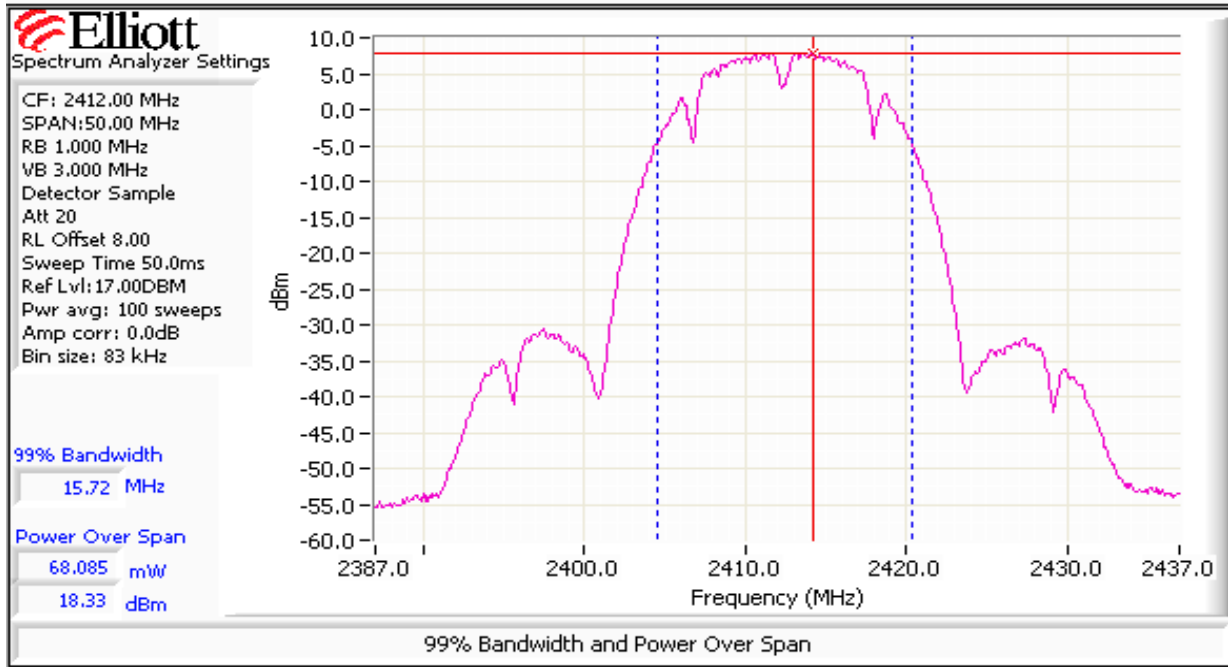

Client: Xirus	Job Number: J71456
Model: XN-16 and XN-8	T-Log Number: T71643
Contact: Steve Smith	Account Manager: Susan Pezli
Standard: -	Class: N/A

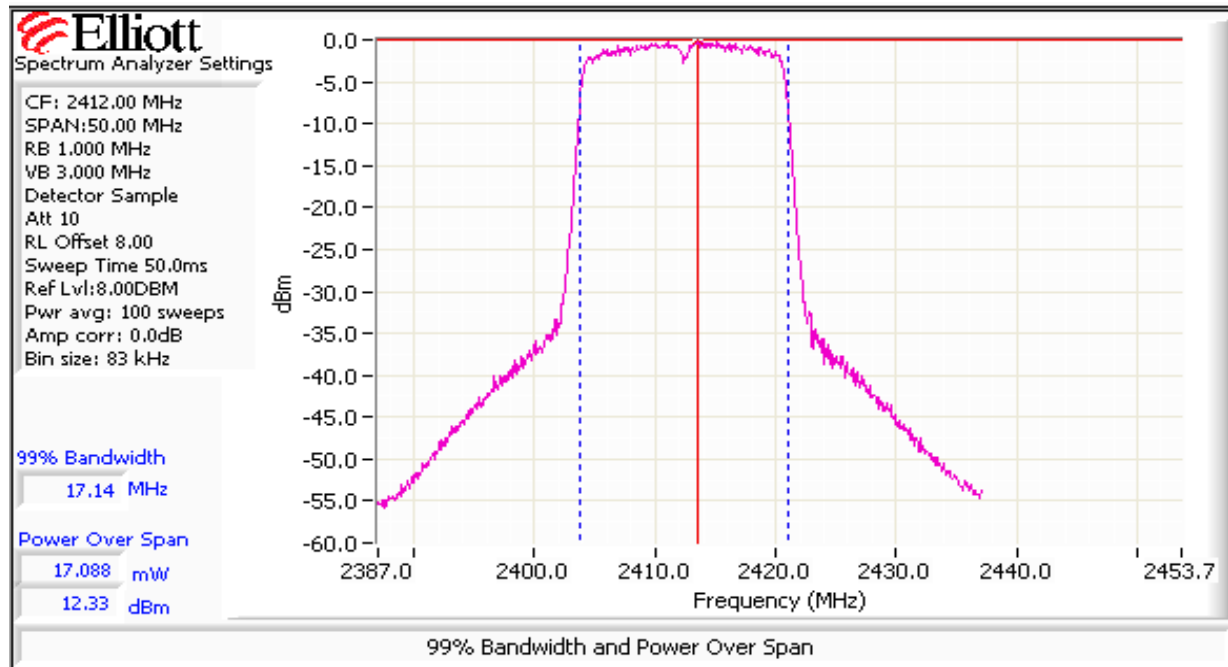
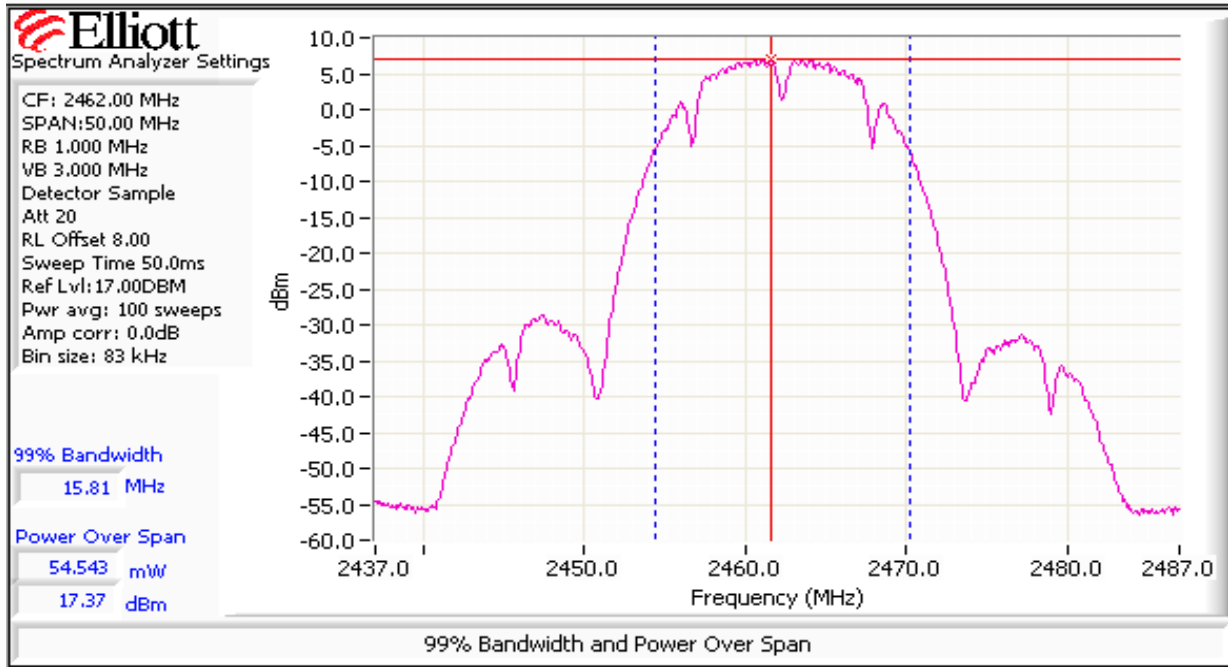

Client: Xirrus	Job Number: J71456
Model: XN-16 and XN-8	T-Log Number: T71643
Contact: Steve Smith	Account Manager: Susan Pezli
Standard: -	Class: N/A

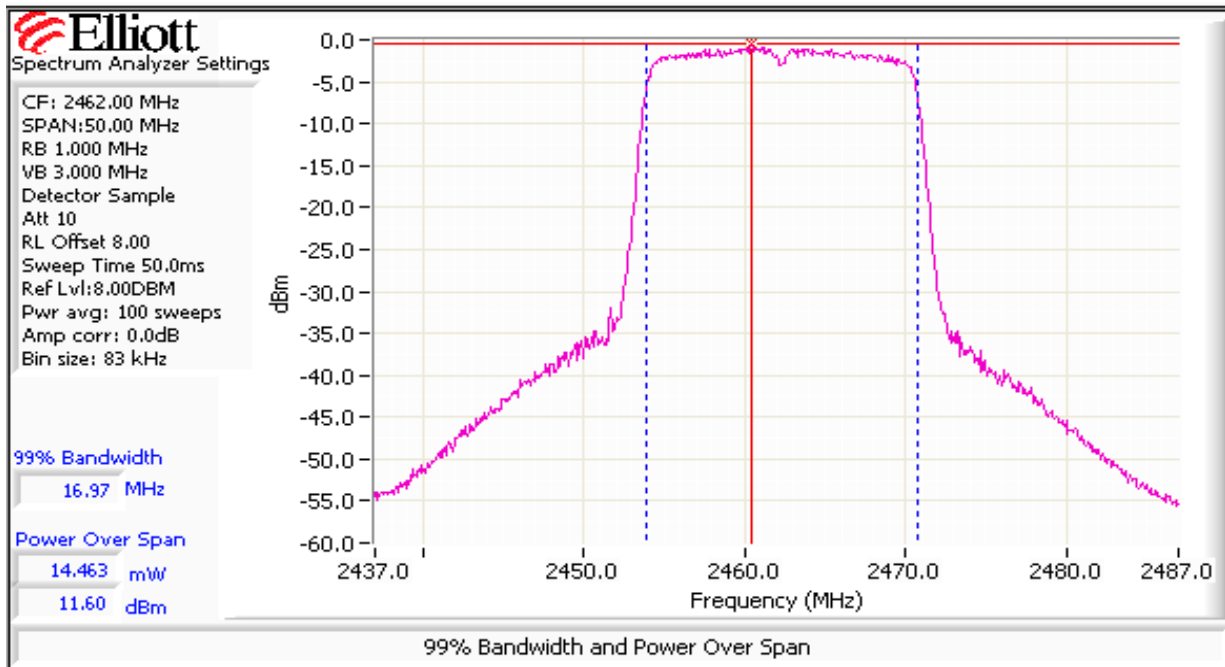
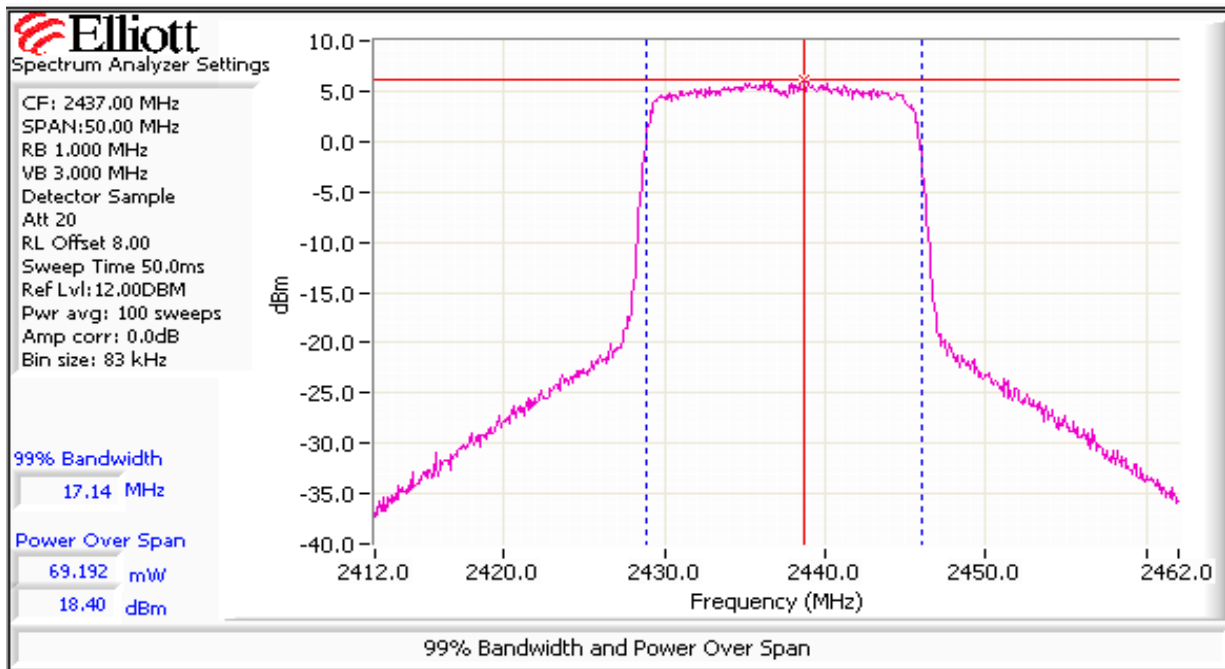

Client: Xirrus	Job Number: J71456
Model: XN-16 and XN-8	T-Log Number: T71643
	Account Manager: Susan Pezli
Contact: Steve Smith	
Standard: -	Class: N/A

Run #2: Power spectral Density
802.11b

Power Setting	Frequency (MHz)	PSD	Limit dBm/3kHz	Result
		(dBm/3kHz) ^{Note 1}		
18.0	2412	-3.9	8.0	Pass
20.0	2437	-2.3	8.0	Pass
18.5	2462	-4.7	8.0	Pass

802.11g

Power Setting	Frequency (MHz)	PSD	Limit dBm/3kHz	Result
		(dBm/3kHz) ^{Note 1}		
13.5	2412	-8.7	8.0	Pass
20.0	2437	1.1	8.0	Pass
13.5	2462	-10.9	8.0	Pass

Note 1:	Power spectral density measured using RB=3 kHz, VB=10kHz, analyzer with peak detector and with a sweep time set to ensure a dwell time of at least 1 second per 3kHz. The measurement is made at the frequency of PPSD determined from preliminary scans using RB=3kHz using multiple sweeps at a faster rate over the 6dB bandwidth of the signal.
Note 2:	The operation of multiple radios in the band does not affect power spectral density as radios cannot operate on overlapping channels.

Client: Xirrus	Job Number: J71456
Model: XN-16 and XN-8	T-Log Number: T71643
Contact: Steve Smith	Account Manager: Susan Pezli
Standard: -	Class: N/A

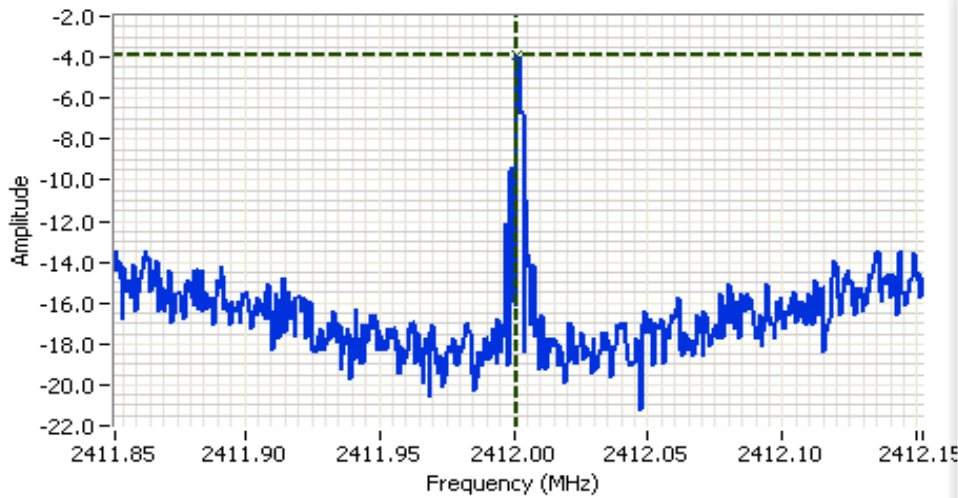

Analyzer Settings
 HP8564E,006,EMI,UK6
 CF: 2412.002 MHz
 SPAN:300 kHz
 RB 3.00 kHz
 VB 10.00 kHz
 Detector POS
 Att 10
 RL Offset 8.00
 Sweep Time 100.0s
 Ref Lvl:1.90DBM

Comments
 PSD: -3.9 dBm/3kHz
 802.11b single chain

Cursor 1 2412.0015 -3.93

0.0000 0.00

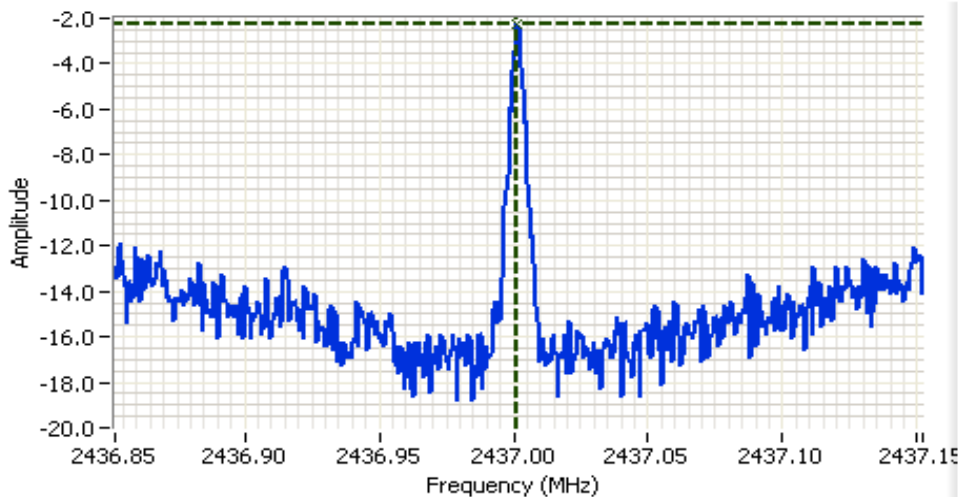

Analyzer Settings
 HP8564E,006,EMI,UK6
 CF: 2437.002 MHz
 SPAN:300 kHz
 RB 3.00 kHz
 VB 10.00 kHz
 Detector POS
 Att 10
 RL Offset 8.00
 Sweep Time 100.0s
 Ref Lvl:3.40DBM

Comments
 PSD: -2.3 dBm/3kHz
 802.11b single chain

Cursor 1 2437.0015 -2.27

0.0000 0.00



Client: Xirrus	Job Number: J71456
Model: XN-16 and XN-8	T-Log Number: T71643
Contact: Steve Smith	Account Manager: Susan Pezli
Standard: -	Class: N/A

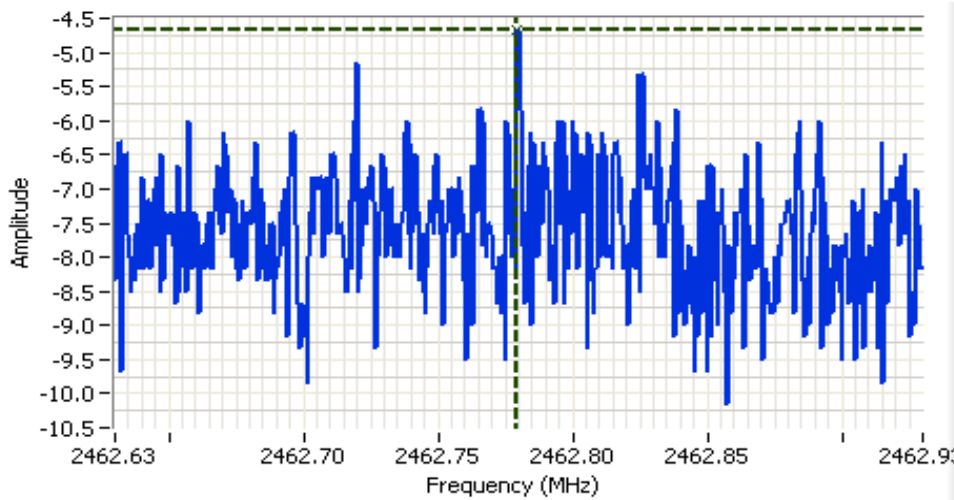

Analyzer Settings
 HP8564E,006,EMI,UK6
 CF: 2462.780 MHz
 SPAN:300 kHz
 RB 3.00 kHz
 VB 10.00 kHz
 Detector POS
 Att 10
 RL Offset 8.00
 Sweep Time 100.0s
 Ref Lvl:-2.00DBM

Comments
 PSD: -4.7 dBm/3kHz
 802.11b single chain

Cursor 1 2462.7795 -4.67

0.0000 0.00

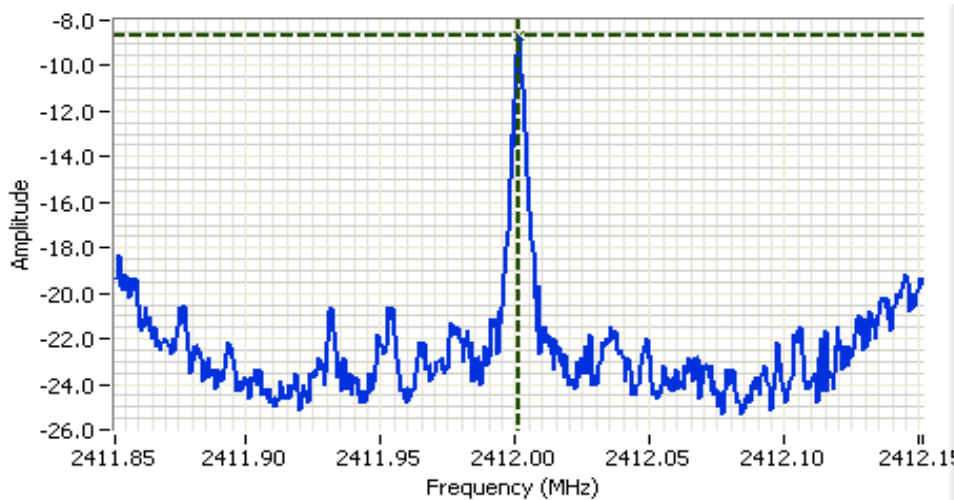

Analyzer Settings
 HP8564E,006,EMI,UK6
 CF: 2412.001 MHz
 SPAN:300 kHz
 RB 3.00 kHz
 VB 10.00 kHz
 Detector POS
 Att 10
 RL Offset 8.00
 Sweep Time 100.0s
 Ref Lvl:-8.00DBM

Comments
 PSD: -8.7 dBm/3kHz
 802.11g single chain

Cursor 1 2412.0012 -8.67

0.0000 0.00



Client: Xirus	Job Number: J71456
Model: XN-16 and XN-8	T-Log Number: T71643
Contact: Steve Smith	Account Manager: Susan Pezli
Standard: -	Class: N/A

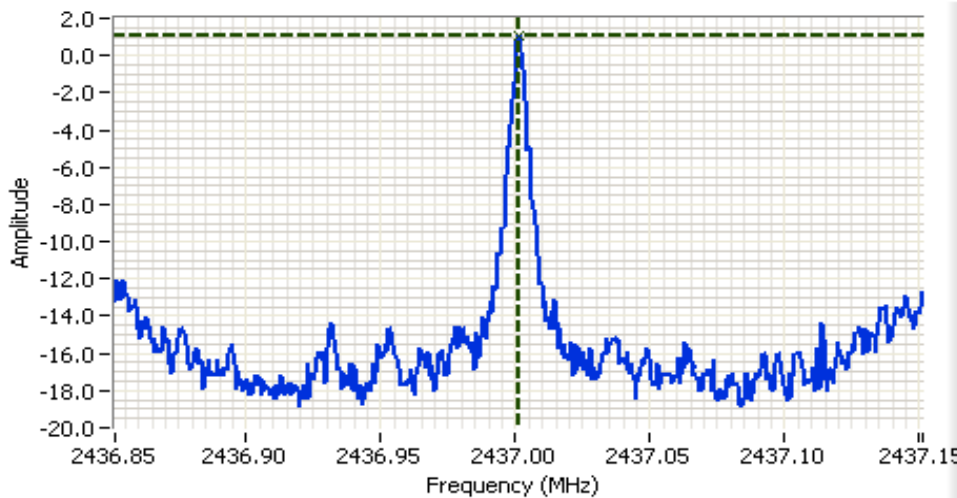

Analyzer Settings
 HP8564E,006,EMI,UK6
 CF: 2437.001 MHz
 SPAN:300 kHz
 RB 3.00 kHz
 VB 10.00 kHz
 Detector POS
 Att 10
 RL Offset 8.00
 Sweep Time 100.0s
 Ref Lvl:4.60DBM

Comments
 PSD: 1.1 dBm/3kHz
 802.11g single chain

Cursor 1 2437.0012 1.10 [Icons]
 0.0000 0.00 [Icons]

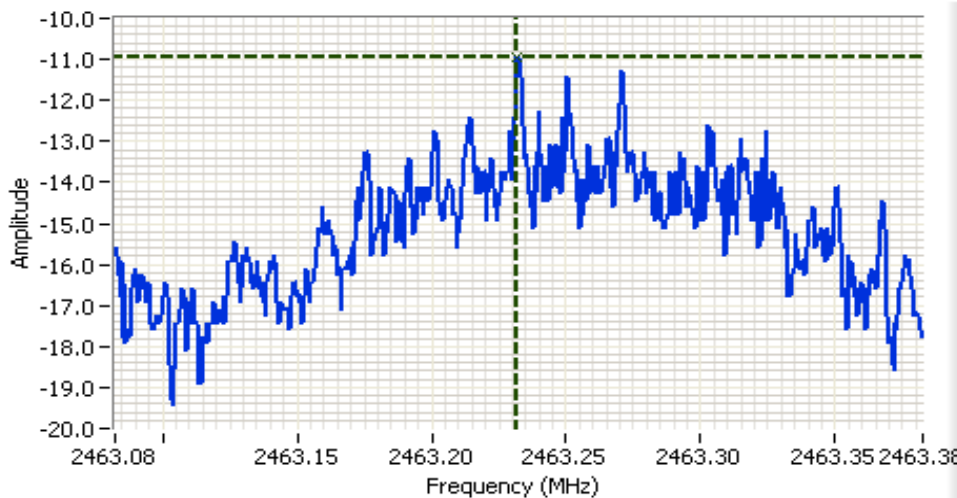

Analyzer Settings
 HP8564E,006,EMI,UK6
 CF: 2463.232 MHz
 SPAN:300 kHz
 RB 3.00 kHz
 VB 10.00 kHz
 Detector POS
 Att 10
 RL Offset 8.00
 Sweep Time 100.0s
 Ref Lvl:-8.10DBM

Comments
 PSD: -10.9 dBm/3kHz
 802.11g single chain

Cursor 1 2463.2319 -10.93 [Icons]
 0.0000 0.00 [Icons]



Client: Xirrus	Job Number: J71456
Model: XN-16 and XN-8	T-Log Number: T71643
	Account Manager: Susan Pezl
Contact: Steve Smith	
Standard: -	Class: N/A

Run #3: Signal Bandwidth

Mode	Power Setting	Frequency (MHz)	Resolution Bandwidth	Bandwidth (MHz)	
				6dB	99%
802.11b	18.0	2412	100kHz	11.1	15.7
802.11b	20.0	2437	100kHz	10.0	15.8
802.11b	18.5	2462	100kHz	10.2	15.8
802.11g	13.5	2412	100kHz	16.3	17.1
802.11g	20.0	2437	100kHz	16.4	17.1
802.11g	13.5	2462	100kHz	16.4	17.0

Note 1: 99% bandwidth measured in accordance with RSS GEN, with RB > 1% of the span and VB > 3xRB



Analyzer Settings

HP8564E,006,EMI,UK6
 CF: 2412.000 MHz
 SPAN:50.000 MHz
 RB 100 kHz
 VB 100 kHz
 Detector POS
 Att 20
 RL Offset 8.00
 Sweep Time 50.0ms
 Ref Lvl:17.00DBM

Comments

6dB BW: 11.083 MHz
 802.11b single chain

Cursor 1	2418.5000	6.33		Delta Freq.	11.083	
Cursor 2	2407.4167	0.33		Delta Amplitude	6.00	

Client: Xirrus	Job Number: J71456
Model: XN-16 and XN-8	T-Log Number: T71643
Contact: Steve Smith	Account Manager: Susan Pezli
Standard: -	Class: N/A



Analyzer Settings
 HP8564E,006,EMI,UK6
 CF: 2437.000 MHz
 SPAN:50.000 MHz
 RB 100 kHz
 VB 100 kHz
 Detector POS
 Att 20
 RL Offset 8.00
 Sweep Time 50.0ms
 Ref Lvl:17.00DBM

Comments
 6dB BW: 10.000 MHz
 802.11b single chain

Cursor 1	2442.5000	7.33	
Cursor 2	2432.5000	1.33	

Delta Freq. 10.000
 Delta Amplitude 6.00

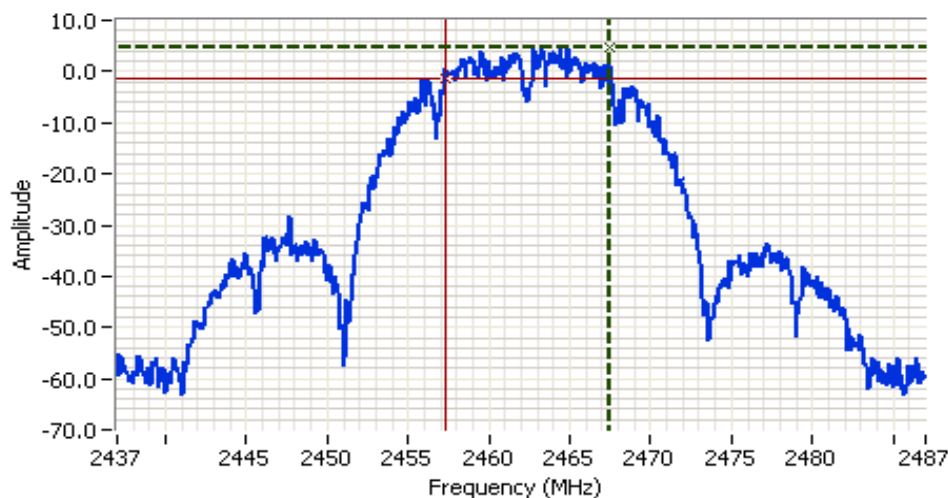

Analyzer Settings
 HP8564E,006,EMI,UK6
 CF: 2462.000 MHz
 SPAN:50.000 MHz
 RB 100 kHz
 VB 100 kHz
 Detector POS
 Att 20
 RL Offset 8.00
 Sweep Time 50.0ms
 Ref Lvl:17.00DBM

Comments
 6dB BW: 10.167 MHz
 802.11b single chain

Cursor 1	2467.5000	4.67	
Cursor 2	2457.3333	-1.33	

Delta Freq. 10.167
 Delta Amplitude 6.00



Client: Xirus	Job Number: J71456
Model: XN-16 and XN-8	T-Log Number: T71643
Contact: Steve Smith	Account Manager: Susan Pezli
Standard: -	Class: N/A



Analyzer Settings
 HP8564E,006,EMI,UK6
 CF: 2412.000 MHz
 SPAN:50.000 MHz
 RB 100 kHz
 VB 100 kHz
 Detector POS
 Att 10
 RL Offset 8.00
 Sweep Time 50.0ms
 Ref Lvl:3.90DBM

Comments
 6dB BW: 16.333 MHz
 802.11g single chain

Cursor 1	2420.6667	-0.43	⊕ ⊖	Delta Freq.	16.333
Cursor 2	2404.3333	-6.43	⊕ ⊖	Delta Amplitude	6.00

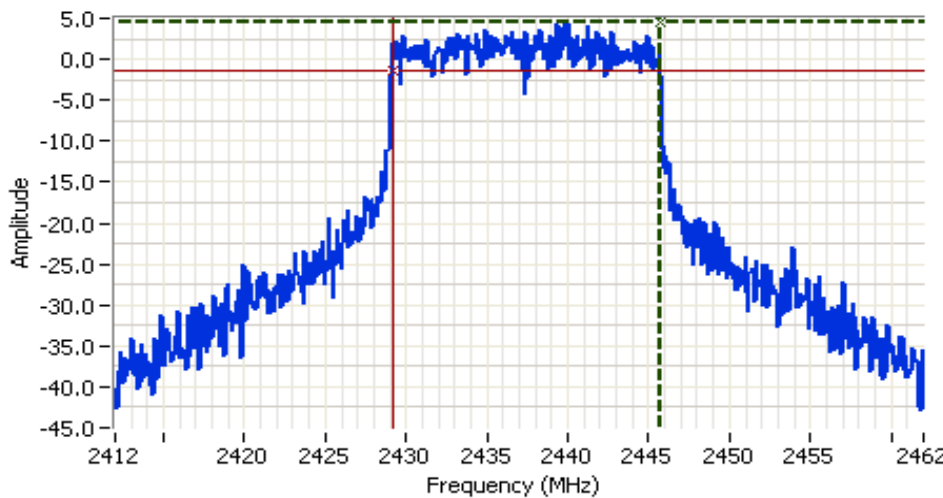

Analyzer Settings
 HP8564E,006,EMI,UK6
 CF: 2437.000 MHz
 SPAN:50.000 MHz
 RB 100 kHz
 VB 100 kHz
 Detector POS
 Att 20
 RL Offset 8.00
 Sweep Time 50.0ms
 Ref Lvl:9.30DBM

Comments
 6dB BW: 16.417 MHz
 802.11g single chain

Cursor 1	2445.6667	4.63	⊕ ⊖	Delta Freq.	16.417
Cursor 2	2429.2500	-1.37	⊕ ⊖	Delta Amplitude	6.00

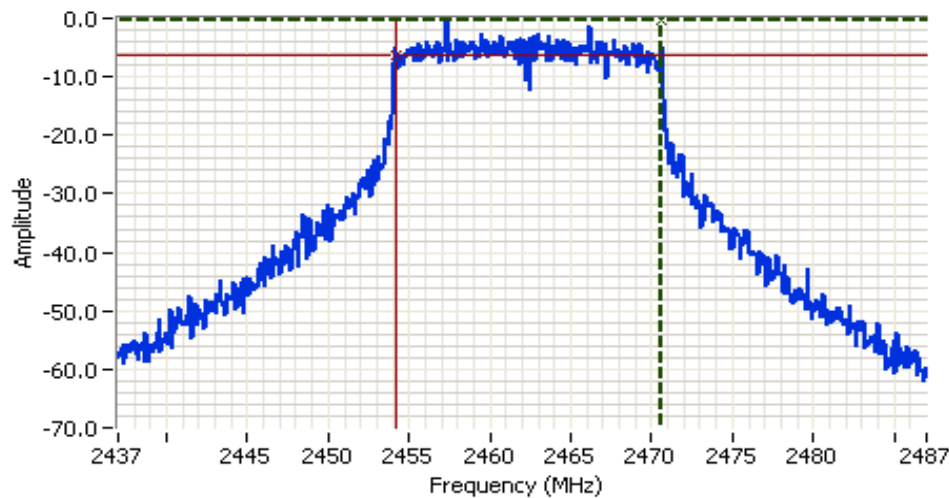

Client: Xirrus	Job Number: J71456
Model: XN-16 and XN-8	T-Log Number: T71643
Contact: Steve Smith	Account Manager: Susan Pezli
Standard: -	Class: N/A

Analyzer Settings

HP8564E,006,EMI,UK6
 CF: 2462.000 MHz
 SPAN:50.000 MHz
 RB 100 kHz
 VB 100 kHz
 Detector POS
 Att 10
 RL Offset 8.00
 Sweep Time 50.0ms
 Ref Lvl:3.60DBM

Comments

6dB BW: 16.417 MHz
 802.11g single chain

Cursor 1	2470.5833	-0.23			
Cursor 2	2454.1667	-6.23			

Delta Freq. 16.417
 Delta Amplitude 6.00

Run #4: Out of Band Spurious Emissions

Frequency (MHz)	Limit	Result
2412, 802.11b	-30dBc	Pass
2437, 802.11b	-30dBc	Pass
2462, 802.11b	-30dBc	Pass
2412, 802.11g	-30dBc	Pass
2437, 802.11g	-30dBc	Pass
2462, 802.11g	-30dBc	Pass

Note 1: Measured using RB>=100kHz, VB>= RB

Client: Xirrus	Job Number: J71456
Model: XN-16 and XN-8	T-Log Number: T71643
	Account Manager: Susan Pezli
Contact: Steve Smith	
Standard: -	Class: N/A

Plots for low channel - 802.11b - , power setting(s) = 18.0

Out Of Band Spurious Emissions - 2412 MHz (802.11b)

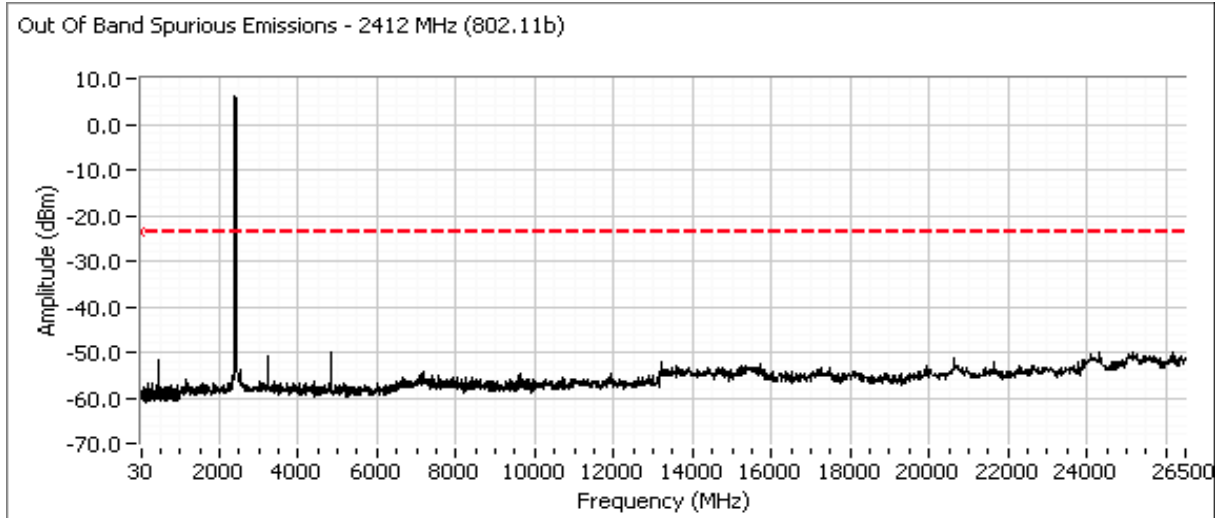

Out Of Band Spurious Emissions - 2412 MHz (802.11b)

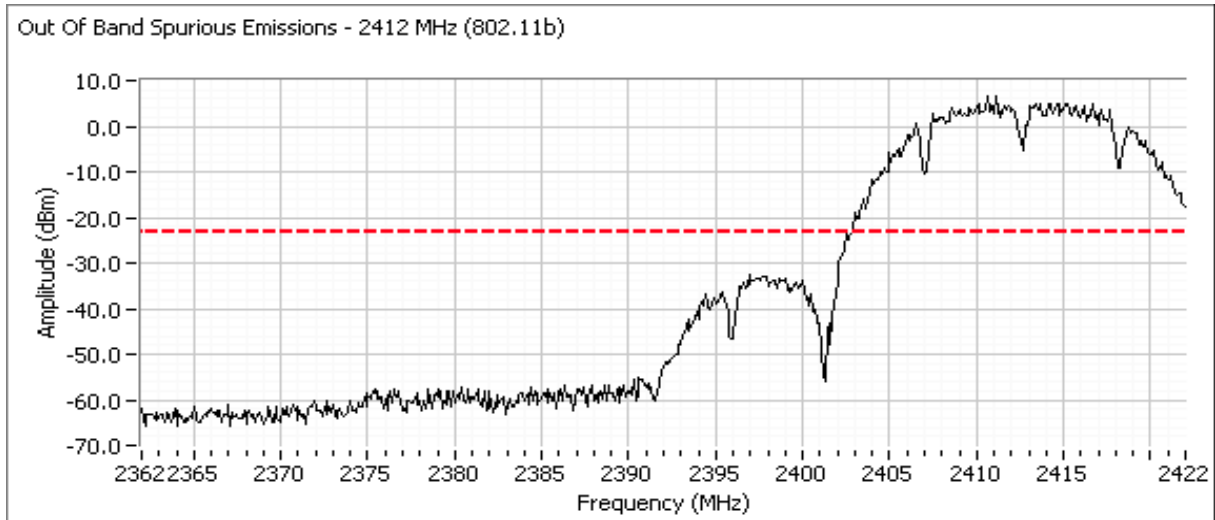

Client: Xirrus	Job Number: J71456
Model: XN-16 and XN-8	T-Log Number: T71643
	Account Manager: Susan Pezli
Contact: Steve Smith	
Standard: -	Class: N/A

Plots for center channel - 802.11b - , power setting(s) = 20.0

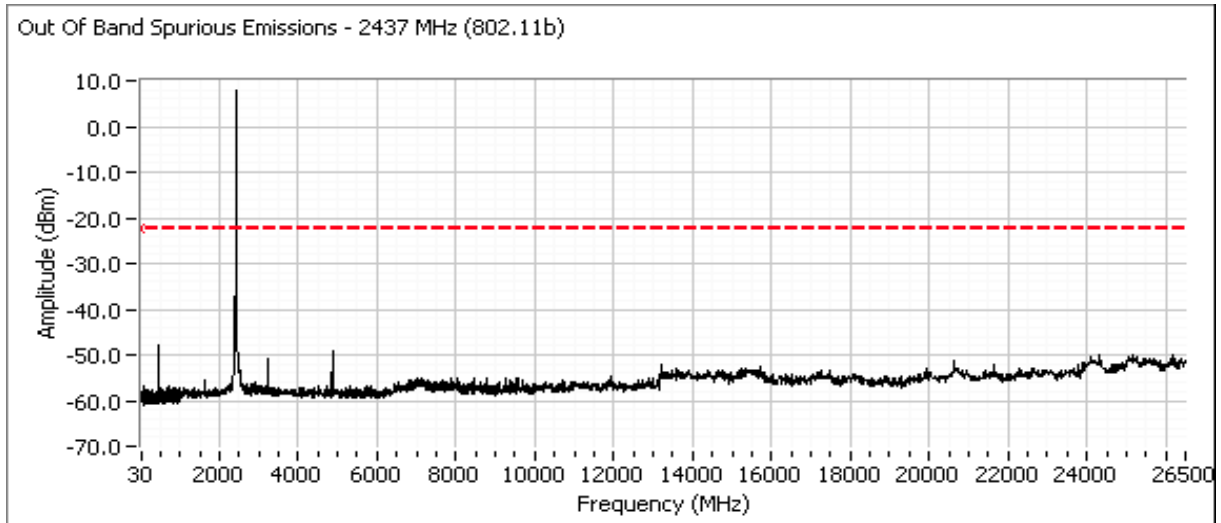

Plots for high channel - 802.11b - , power setting(s) = 18.5

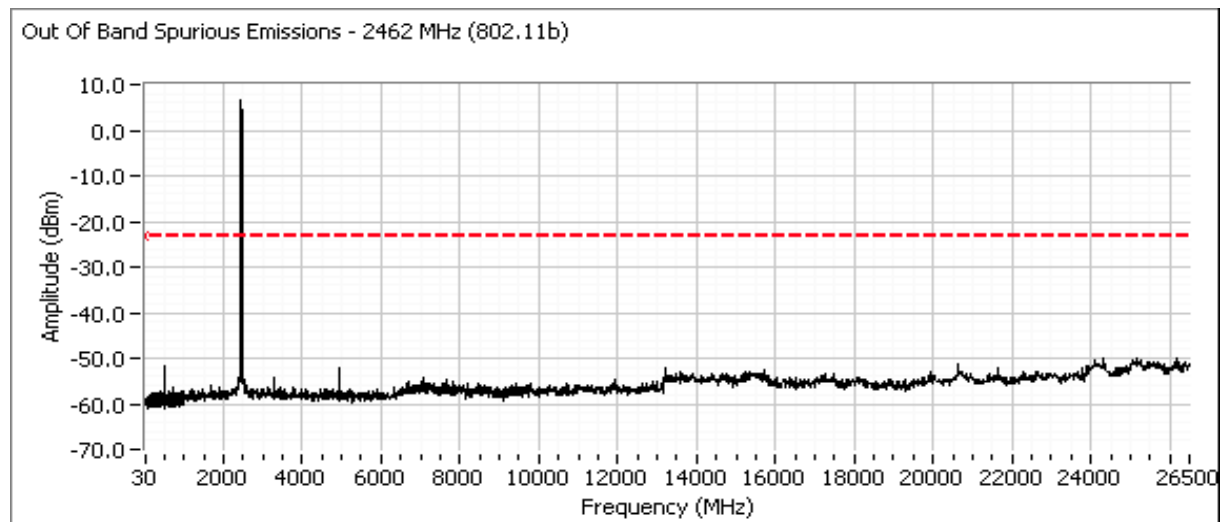

Client: Xirrus	Job Number: J71456
Model: XN-16 and XN-8	T-Log Number: T71643
	Account Manager: Susan Pezli
Contact: Steve Smith	
Standard: -	Class: N/A

Plots for low channel - 802.11g - , power setting(s) = 13.5

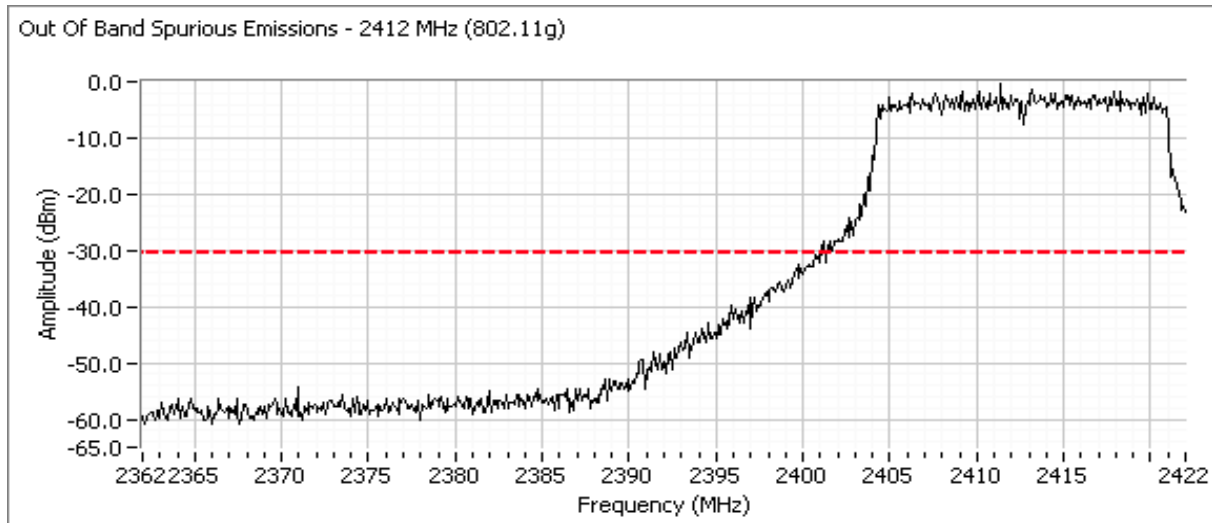
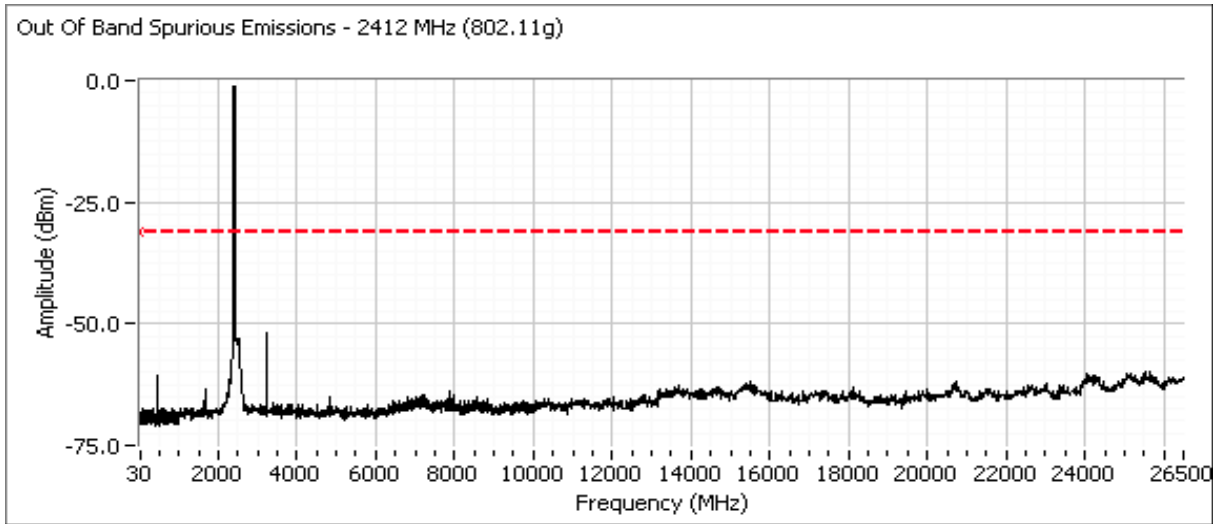

Client: Xirrus	Job Number: J71456
Model: XN-16 and XN-8	T-Log Number: T71643
	Account Manager: Susan Pezli
Contact: Steve Smith	
Standard: -	Class: N/A

Plots for center channel - 802.11g - , power setting(s) = 20.0

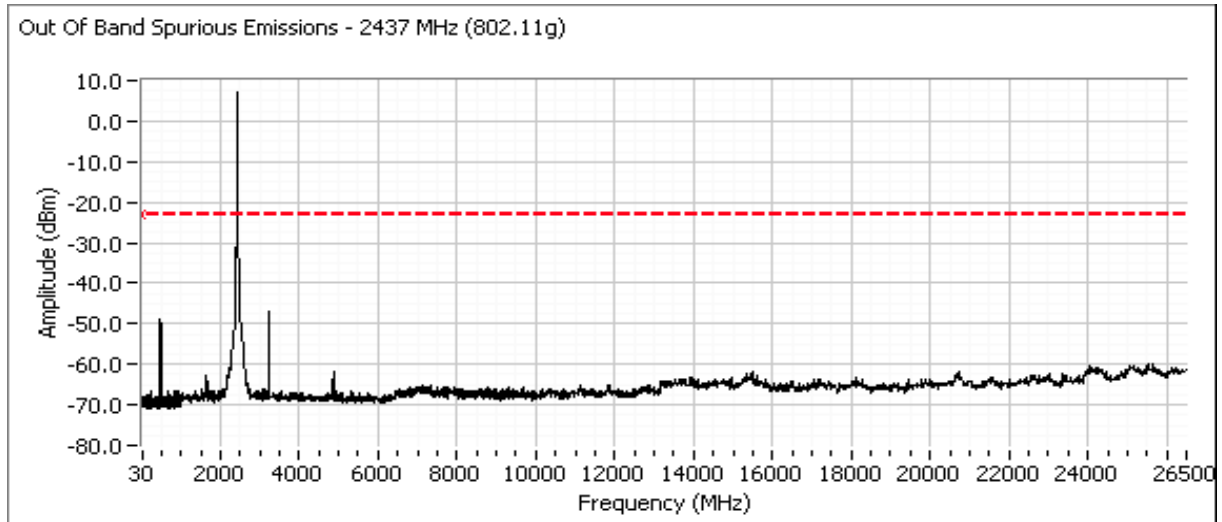

Plots for high channel - 802.11g - , power setting(s) = 13.5

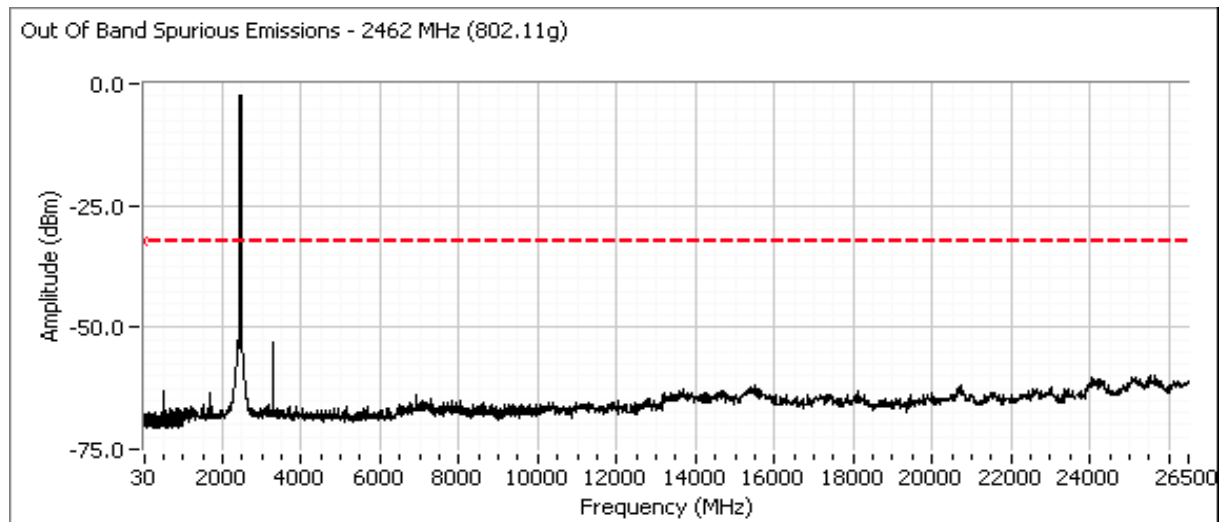

Client:	Xirrus	Job Number:	J71456
Model:	XN-16 and XN-8	T-Log Number:	T71643
Contact:	Steve Smith	Account Manager:	Susan Pezli
Standard:	-	Class:	N/A

RSS 210 and FCC 15.247 (DTS) Antenna Port Measurements
MIMO and Smart Antenna Systems
Power, PSD, Bandwidth and Spurious Emissions

Test Specific Details

Objective: The objective of this test session is to perform final qualification testing of the EUT with respect to the specification listed above.

Date of Test: 6/4/2008 Config. Used: -
 Test Engineer: Mehran Birgani Config Change: -
 Test Location: Chamber #2 EUT Voltage: POE

General Test Configuration

The EUT was connected to the spectrum analyzer or power meter via a suitable attenuator.

All measurements have been corrected to allow for the external attenuators used.

Ambient Conditions:

Temperature: 16 °C
 Rel. Humidity: 39 %

Summary of Results

Run #	Test Performed	Limit	Pass / Fail	Result / Margin
1	Output Power Chain A+B+C	15.247(b)	Pass	802.11b: 23.7 dBm 802.11g: 28.2 dBm
2	PSD Chain A+B+C	15.247(d)	Pass	802.11b: -0.5 dBm/3kHz 802.11g: 3.2 dBm/3kHz
3	Minimum 6dB Bandwidth	15.247(a)	Pass	802.11b: 9.6 MHz 802.11g: 16.4 MHz
3	99% Bandwidth	RSS GEN	Pass	802.11b: 15.8 MHz 802.11g: 17.1 MHz
4	Spurious emissions	15.247(b)	Pass	All signals were more than 30dB below the fundamental

Modifications Made During Testing

No modifications were made to the EUT during testing

Deviations From The Standard

No deviations were made from the requirements of the standard.



EMC Test Data

Client: Xirrus	Job Number: J71456
Model: XN-16 and XN-8	T-Log Number: T71643
Contact: Steve Smith	Account Manager: Susan Pezli
Standard: -	Class: N/A

Run #1: Output Power - Chain A + B + C
 Transmitted signal on chain is coherent ? Yes

Single radio Operating in the Band

2412 MHz - 802.11b	Chain 1	Chain 2	Chain 3	Chain 4	Total Across All Chains		Limit	
Power Setting ^{Note 3}	17.5	17.5	17.5					
Output Power (dBm) ^{Note 1}	17.2	15.8	15.3		20.9 dBm	0.124 W	28.2 dBm	0.665 W
Antenna Gain (dBi) ^{Note 2}	3.0	3.0	3.0		7.8 dBi		Pass	
eirp (dBm) ^{Note 2}	20.2	18.8	18.3		28.7 dBm	0.745 W		

2437 MHz - 802.11b	Chain 1	Chain 2	Chain 3	Chain 4	Total Across All Chains		Limit	
Power Setting ^{Note 3}	20.0	20.0	20.0					
Output Power (dBm) ^{Note 1}	19.4	18.3	18.9		23.7 dBm	0.232 W	28.2 dBm	0.665 W
Antenna Gain (dBi) ^{Note 2}	3.0	3.0	3.0		7.8 dBi		Pass	
eirp (dBm) ^{Note 2}	22.4	21.3	21.9		31.4 dBm	1.391 W		

2462 MHz - 802.11b	Chain 1	Chain 2	Chain 3	Chain 4	Total Across All Chains		Limit	
Power Setting ^{Note 3}	17.5	17.5	17.5					
Output Power (dBm) ^{Note 1}	16.4	15.7	16.7		21.1 dBm	0.128 W	28.2 dBm	0.665 W
Antenna Gain (dBi) ^{Note 2}	3.0	3.0	3.0		7.8 dBi		Pass	
eirp (dBm) ^{Note 2}	19.4	18.7	19.7		28.8 dBm	0.764 W		

2412 MHz - 802.11g	Chain 1	Chain 2	Chain 3	Chain 4	Total Across All Chains		Limit	
Power Setting ^{Note 3}	14.5	14.5	14.5					
Output Power (dBm) ^{Note 1}	13.3	12.5	11.4		17.2 dBm	0.053 W	28.2 dBm	0.665 W
Antenna Gain (dBi) ^{Note 2}	3.0	3.0	3.0		7.8 dBi		Pass	
eirp (dBm) ^{Note 2}	16.3	15.5	14.4		25.0 dBm	0.317 W		

2437 MHz - 802.11g	Chain 1	Chain 2	Chain 3	Chain 4	Total Across All Chains		Limit	
Power Setting ^{Note 3}	20.0	20.0	20.0					
Output Power (dBm) ^{Note 1}	18.6	17.1	18.5		22.9 dBm	0.195 W	28.2 dBm	0.665 W
Antenna Gain (dBi) ^{Note 2}	3.0	3.0	3.0		7.8 dBi		Pass	
eirp (dBm) ^{Note 2}	21.6	20.1	21.5		30.7 dBm	1.164 W		

2462 MHz - 802.11g	Chain 1	Chain 2	Chain 3	Chain 4	Total Across All Chains		Limit	
Power Setting ^{Note 3}	13.5	13.5	13.5					
Output Power (dBm) ^{Note 1}	11.6	11.2	11.9		16.3 dBm	0.043 W	28.2 dBm	0.665 W
Antenna Gain (dBi) ^{Note 2}	3.0	3.0	3.0		7.8 dBi		Pass	
eirp (dBm) ^{Note 2}	14.6	14.2	14.9		24.1 dBm	0.258 W		

Note 1: Output power measured using a spectrum analyzer (see plots below) with RBW=1MHz, VB=3 MHz, sample detector, power averaging on (transmitted signal was continuous) and power integration over 50 MHz (reference method 1 of FCC DA 02-2138 for U-NII devices, August 30, 2002). Spurious limit becomes -30dBc.

Note 2: As there is coherency between chains the effective antenna gain is the sum of the individual antenna gains and the eirp is the product of the total power and the effective antenna gain

Client: Xirrus	Job Number: J71456
Model: XN-16 and XN-8	T-Log Number: T71643
Contact: Steve Smith	Account Manager: Susan Pezli
Standard: -	Class: N/A

Two radios on non-overlapping channels, note 3

802.11b	Chain 1	Chain 2	Chain 3	Chain 4	Total Across All Chains		Limit	
Power Setting ^{Note 3}	20.0	20.0	20.0					
Output Power (dBm) ^{Note 1}	19.4	18.3	18.9		26.7 dBm	0.465 W	28.2 dBm	0.665 W
Antenna Gain (dBi) ^{Note 2}	3.0	3.0	3.0		7.8 dBi		Pass	
eirp (dBm) ^{Note 2}	22.4	21.3	21.9		34.4 dBm	2.781 W		

802.11g	Chain 1	Chain 2	Chain 3	Chain 4	Total Across All Chains		Limit	
Power Setting ^{Note 3}	20.0	20.0	20.0					
Output Power (dBm) ^{Note 1}	18.6	17.1	18.5		25.9 dBm	0.389 W	28.2 dBm	0.665 W
Antenna Gain (dBi) ^{Note 2}	3.0	3.0	3.0		7.8 dBi		Pass	
eirp (dBm) ^{Note 2}	21.6	20.1	21.5		33.7 dBm	2.329 W		

Three radios on non-overlapping channels, note 3

802.11b	Chain 1	Chain 2	Chain 3	Chain 4	Total Across All Chains		Limit	
Power Setting ^{Note 3}	19.5	19.5	19.5					
Output Power (dBm) ^{Note 1}	18.9	18.2	18.9		28.2 dBm	0.664 W	28.2 dBm	0.665 W
Antenna Gain (dBi) ^{Note 2}	3.0	3.0	3.0		7.8 dBi		Pass	
eirp (dBm) ^{Note 2}	21.9	21.2	21.9		36.0 dBm	3.974 W		

802.11g	Chain 1	Chain 2	Chain 3	Chain 4	Total Across All Chains		Limit	
Power Setting ^{Note 3}	20.0	20.0	20.0					
Output Power (dBm) ^{Note 1}	18.6	17.1	18.5		27.7 dBm	0.584 W	28.2 dBm	0.665 W
Antenna Gain (dBi) ^{Note 2}	3.0	3.0	3.0		7.8 dBi		Pass	
eirp (dBm) ^{Note 2}	21.6	20.1	21.5		35.4 dBm	3.493 W		

Note 1:	Output power measured using a spectrum analyzer (see plots below) with RBW=1MHz, VB=3 MHz, sample detector, power averaging on (transmitted signal was continuous) and power integration over 50 MHz (reference method 1 of FCC DA 02-2138 for U-NII devices, August 30, 2002). Spurious limit becomes -30dBc.
Note 2:	As there is coherency between chains the effective antenna gain is the sum of the individual antenna gains and the eirp is the product of the total power and the effective antenna gain
Note 3:	The device has multiple radios, but the software limits operation in any band to ensure only non-overlapping channels are used (no two radios can operate on the same channel or on overlapping channels). In the 2412 - 2462 MHz band there can be a maximum of 3 radios active. The calculated total power (obtained by multiplying the output power on a single radio by the number of radios that can be operating in the band) demonstrates that, with 2 or 3 radios active, the total output power still complies with the limit.

Client: Xirrus	Job Number: J71456
Model: XN-16 and XN-8	T-Log Number: T71643
Contact: Steve Smith	Account Manager: Susan Pezli
Standard: -	Class: N/A

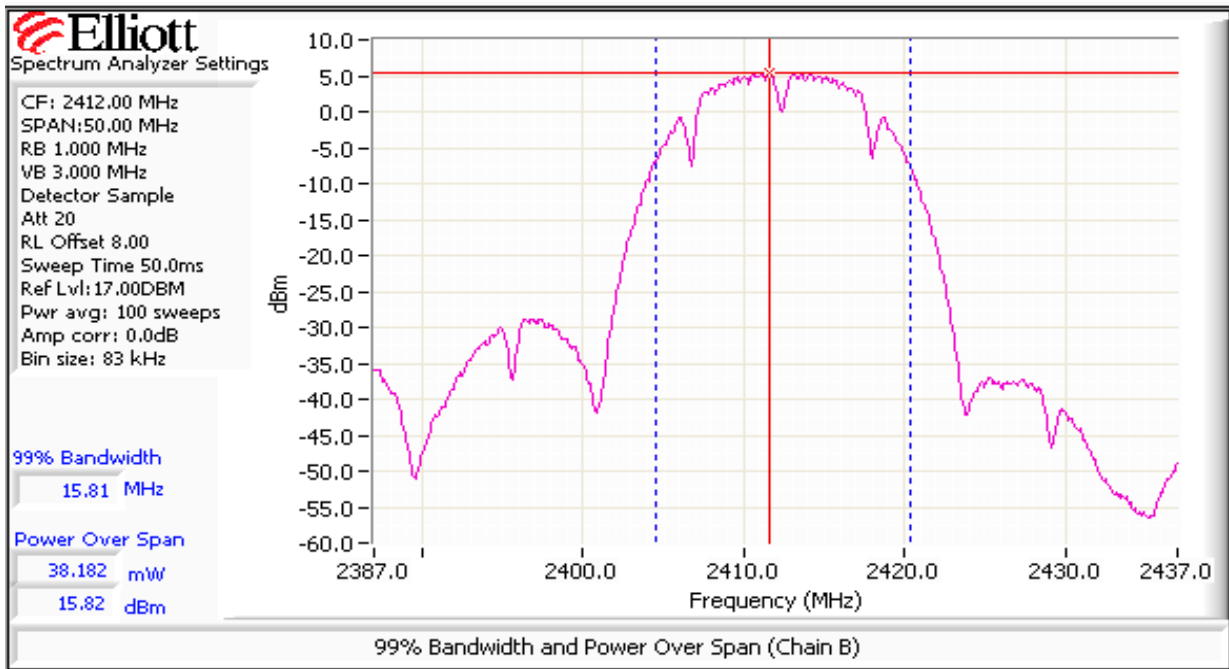
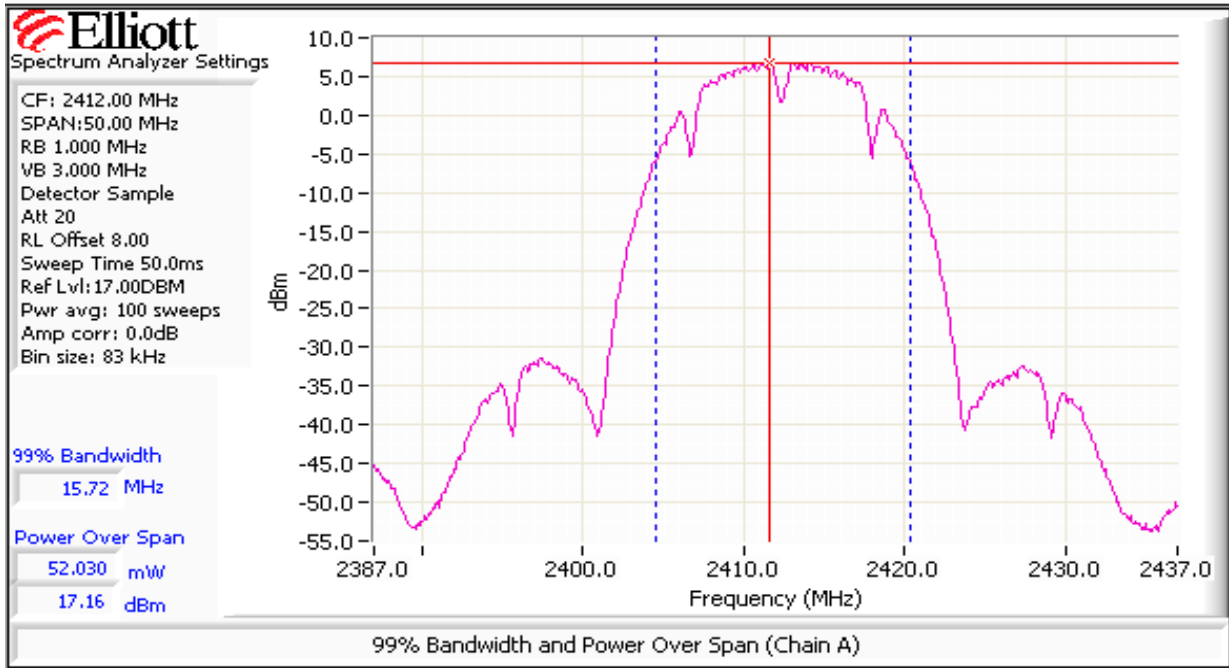

Client: Xirus	Job Number: J71456
Model: XN-16 and XN-8	T-Log Number: T71643
Contact: Steve Smith	Account Manager: Susan Pezli
Standard: -	Class: N/A

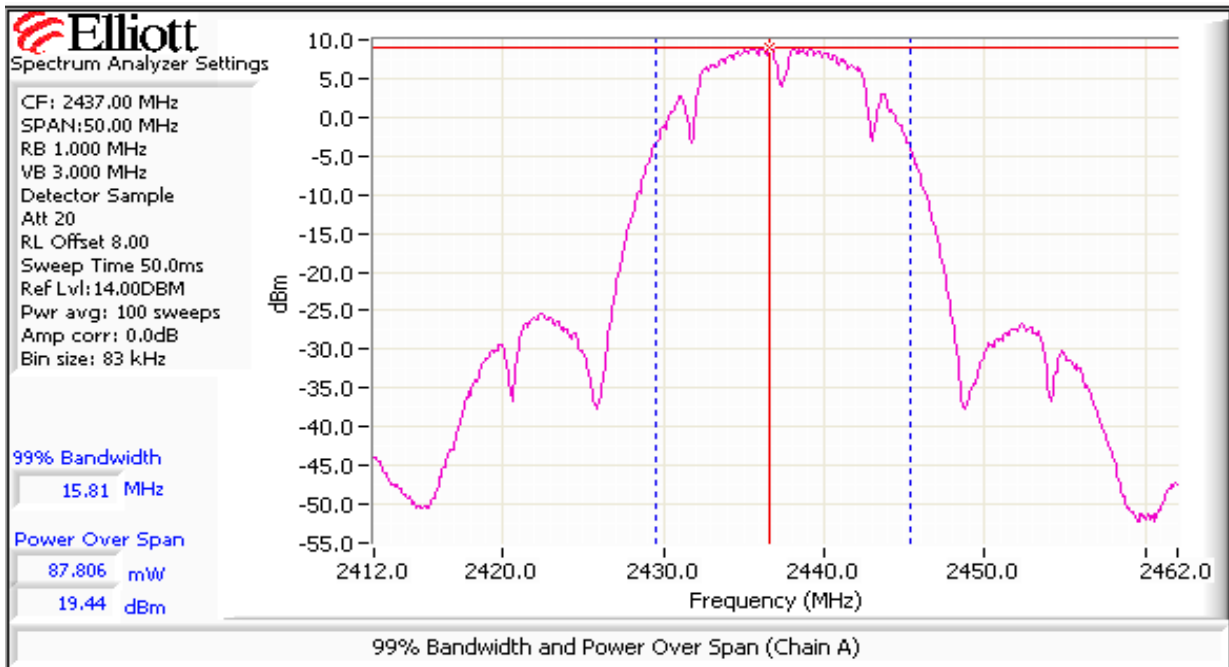
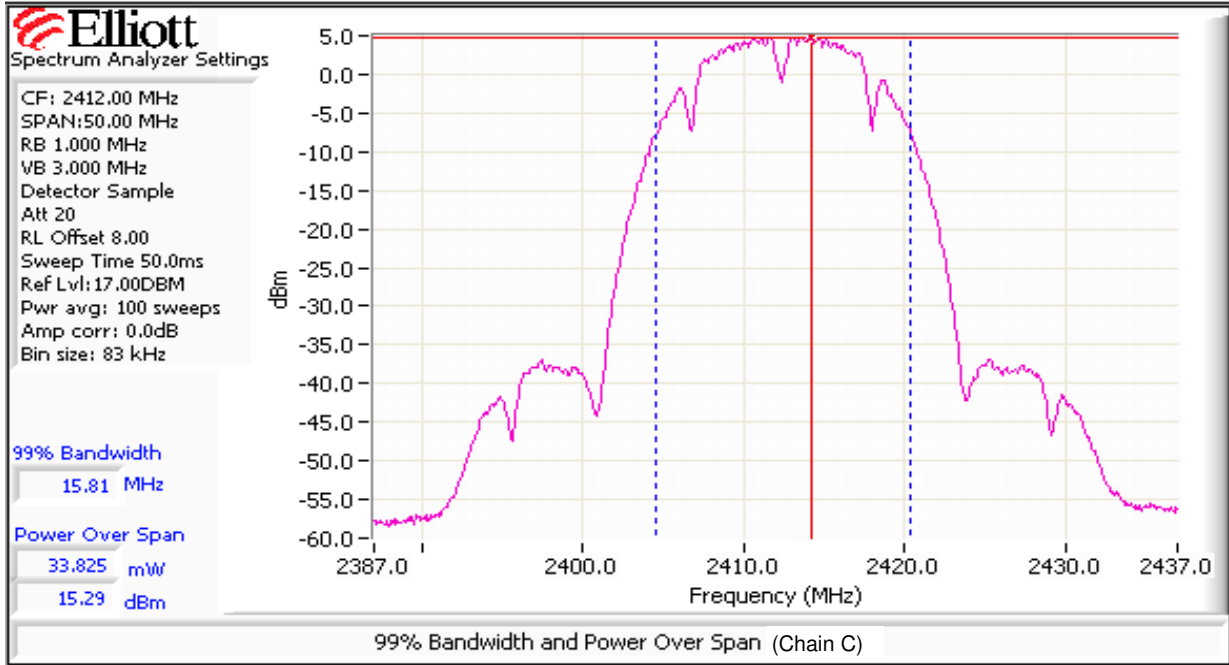

Client: Xirrus	Job Number: J71456
Model: XN-16 and XN-8	T-Log Number: T71643
Contact: Steve Smith	Account Manager: Susan Pezli
Standard: -	Class: N/A

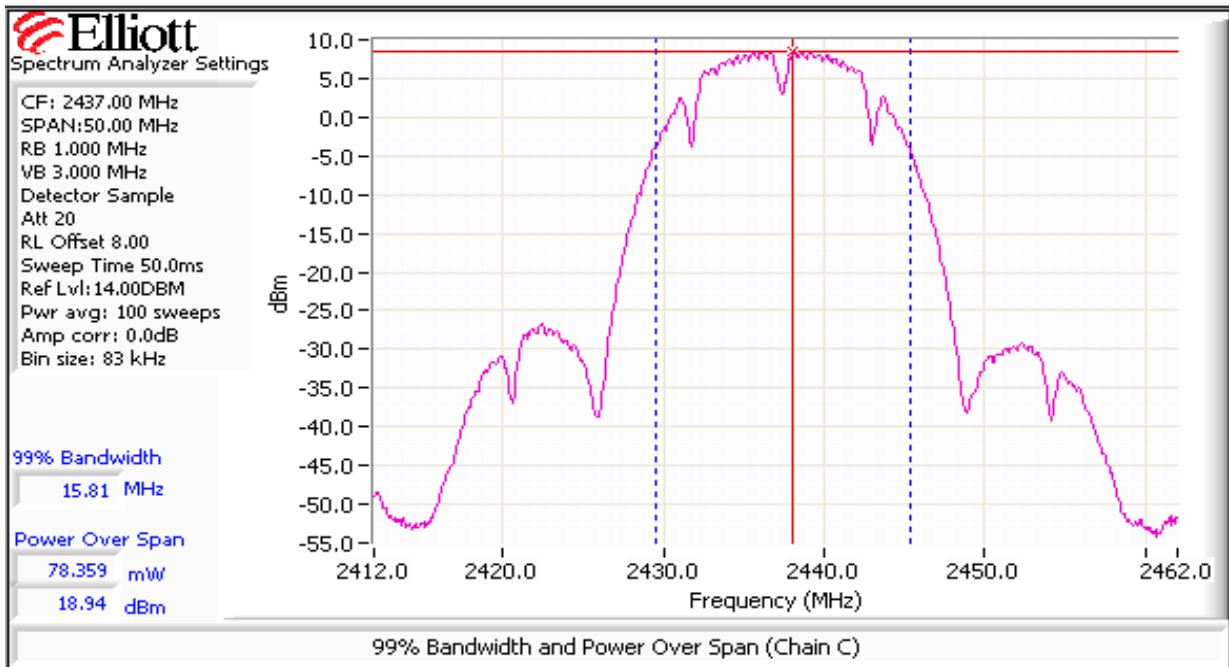
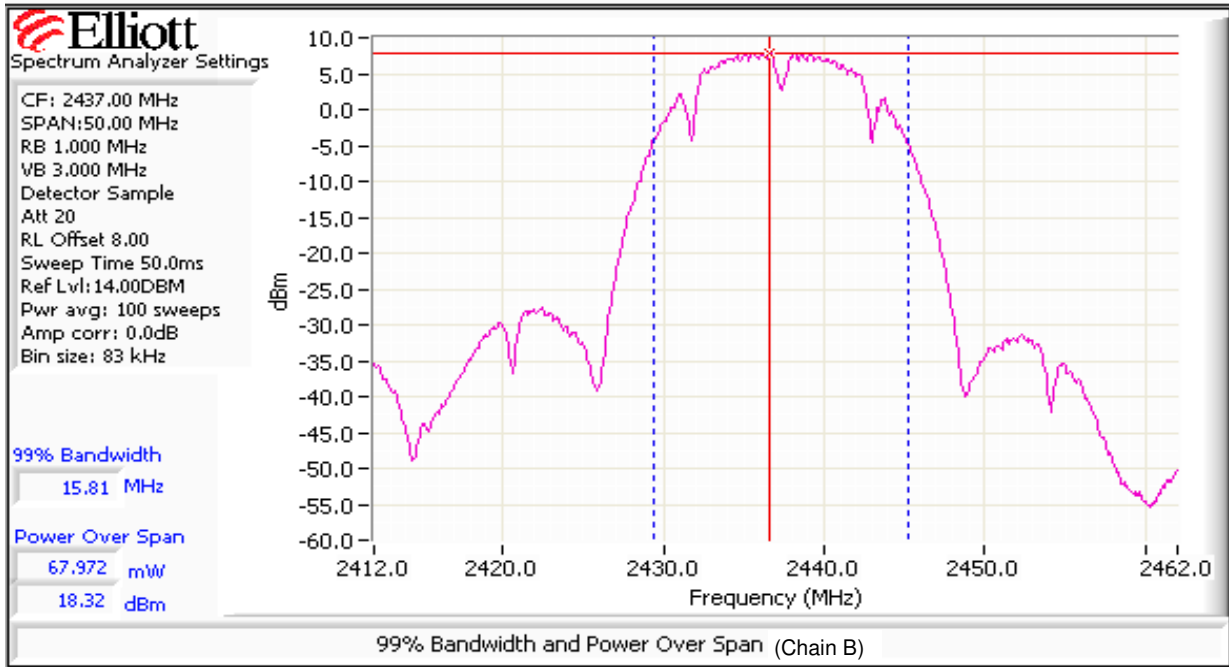

Client: Xirrus	Job Number: J71456
Model: XN-16 and XN-8	T-Log Number: T71643
Contact: Steve Smith	Account Manager: Susan Pezli
Standard: -	Class: N/A

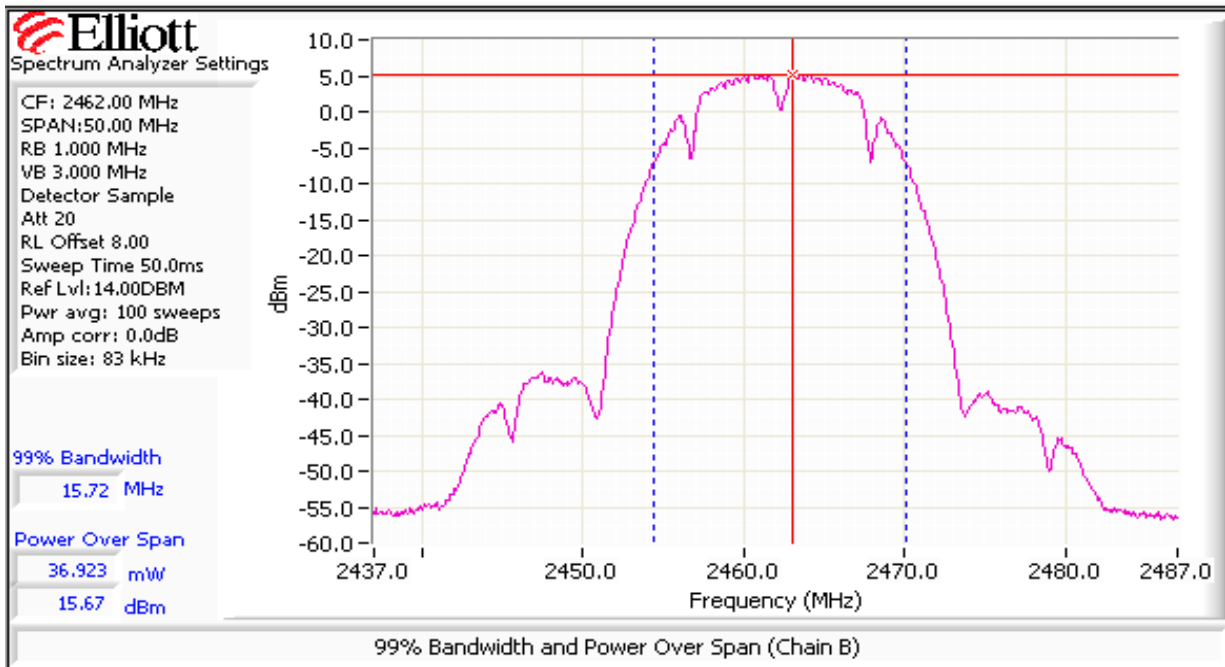
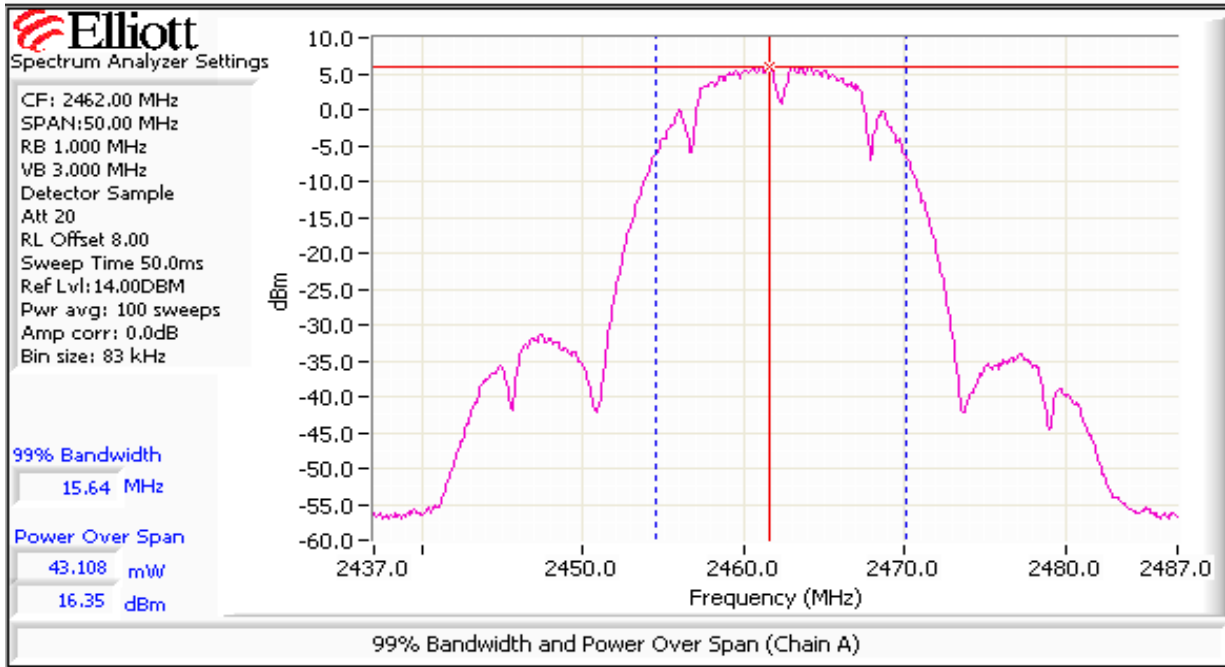

Client: Xirrus	Job Number: J71456
Model: XN-16 and XN-8	T-Log Number: T71643
Contact: Steve Smith	Account Manager: Susan Pezli
Standard: -	Class: N/A

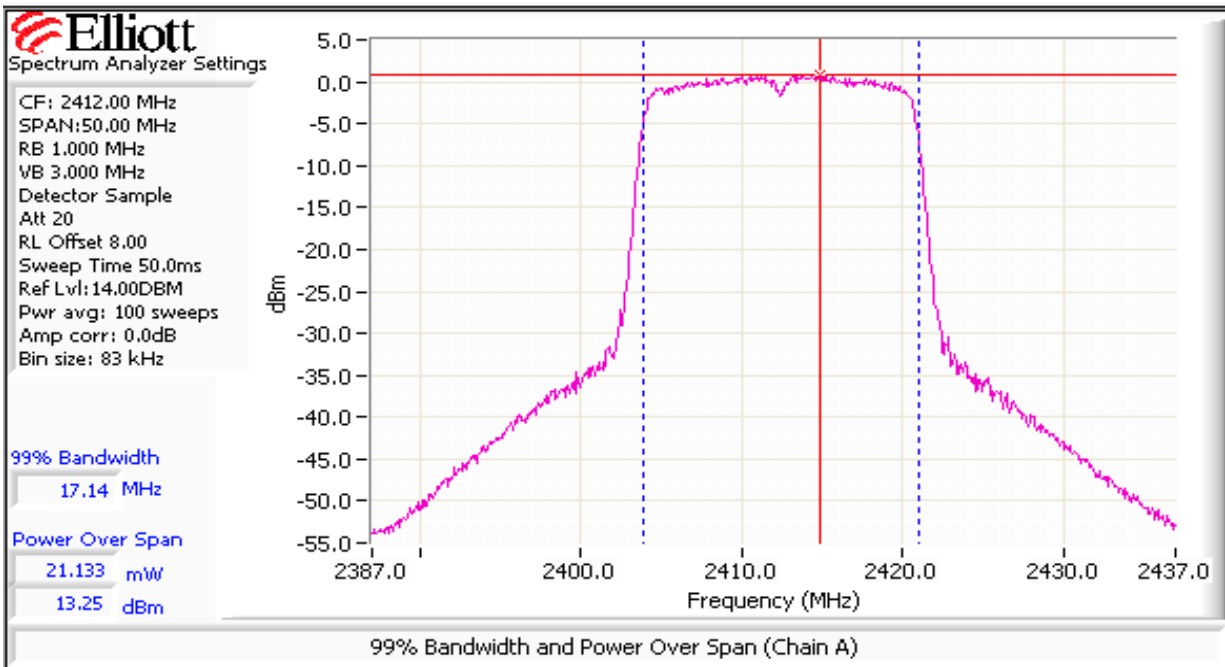
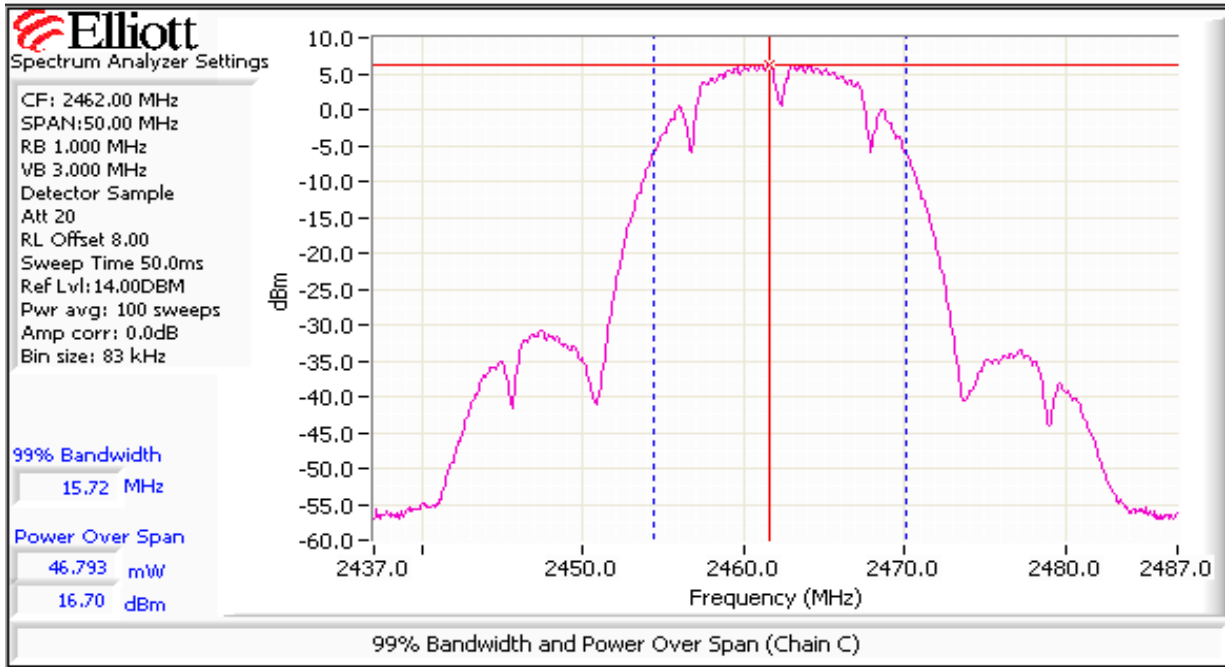

Client: Xirrus	Job Number: J71456
Model: XN-16 and XN-8	T-Log Number: T71643
Contact: Steve Smith	Account Manager: Susan Pezli
Standard: -	Class: N/A

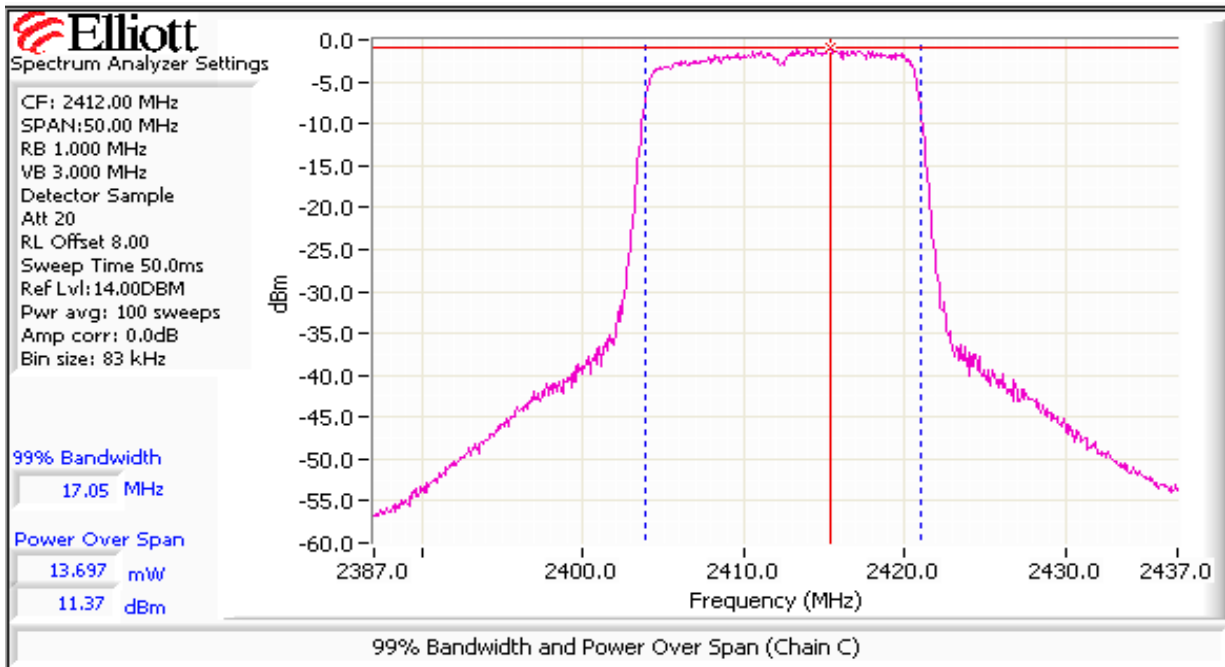
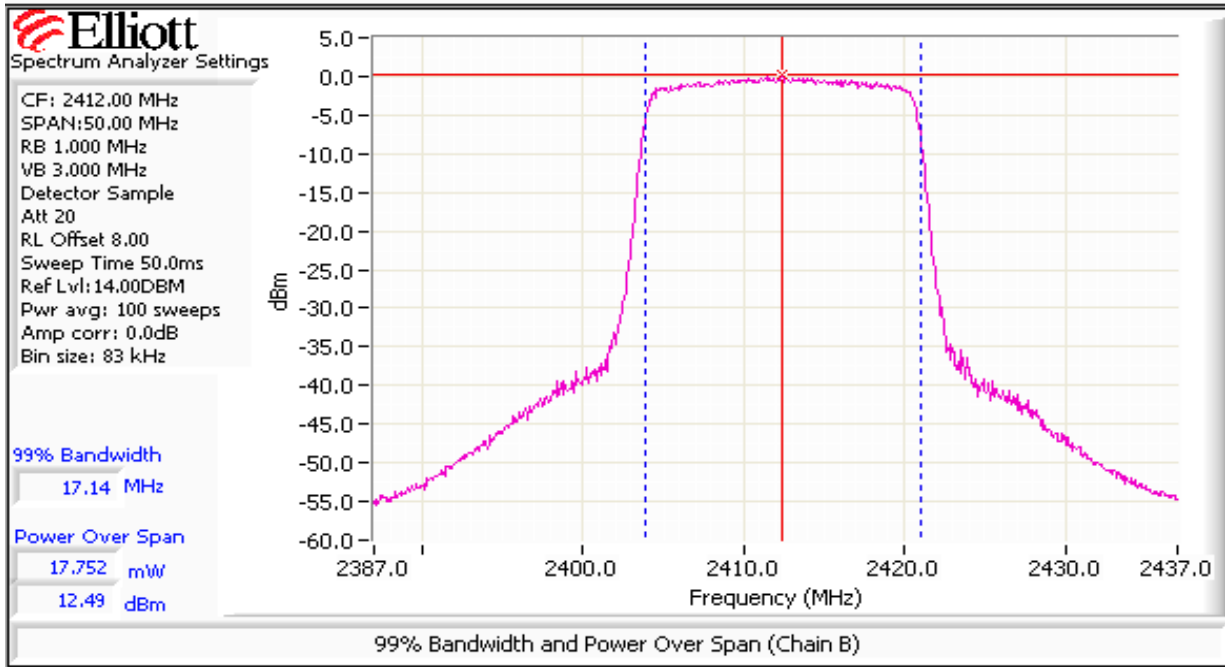

Client: Xirrus	Job Number: J71456
Model: XN-16 and XN-8	T-Log Number: T71643
Contact: Steve Smith	Account Manager: Susan Pezli
Standard: -	Class: N/A

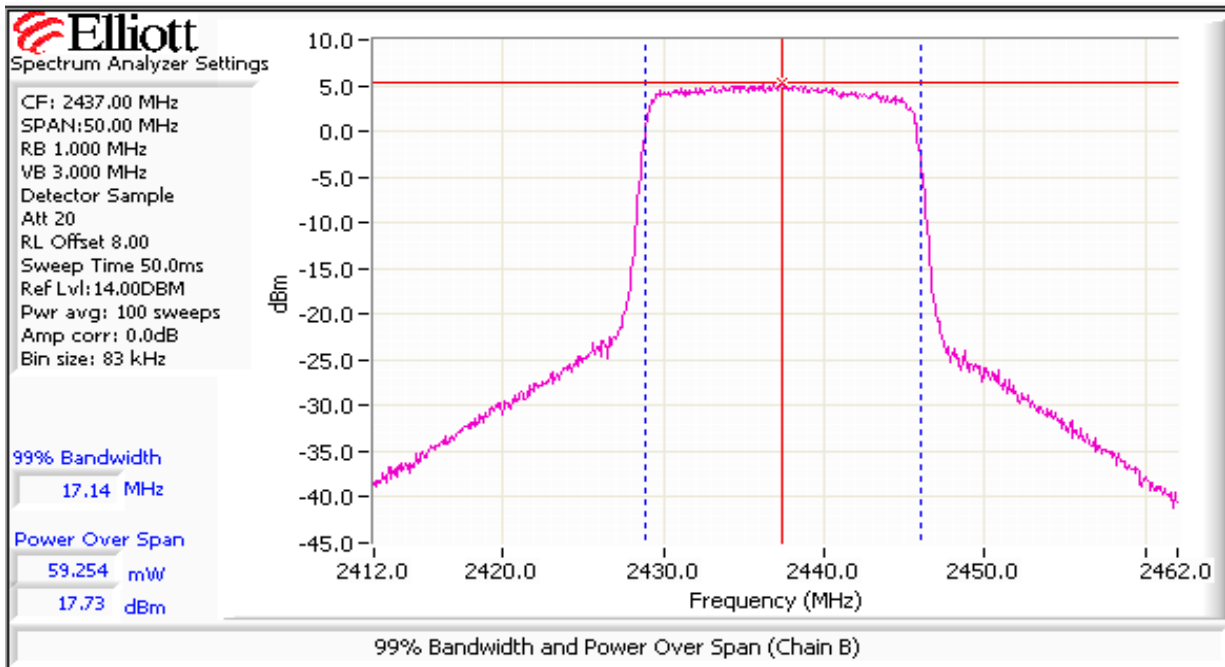
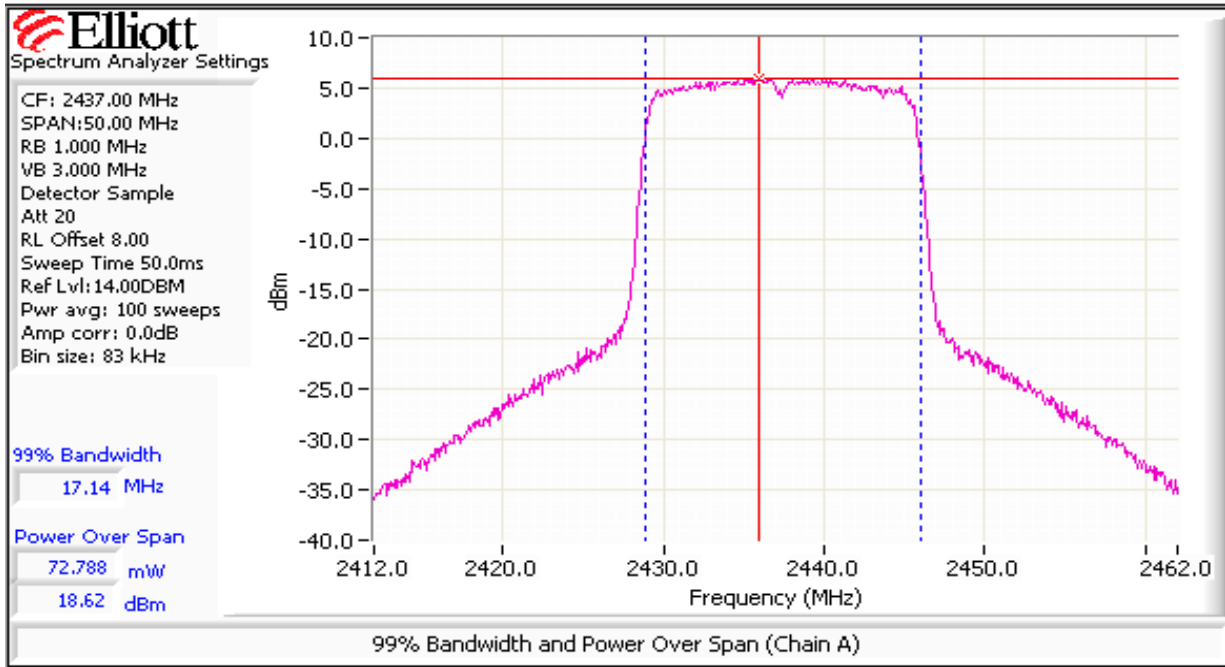

Client: Xirrus	Job Number: J71456
Model: XN-16 and XN-8	T-Log Number: T71643
Contact: Steve Smith	Account Manager: Susan Pezli
Standard: -	Class: N/A

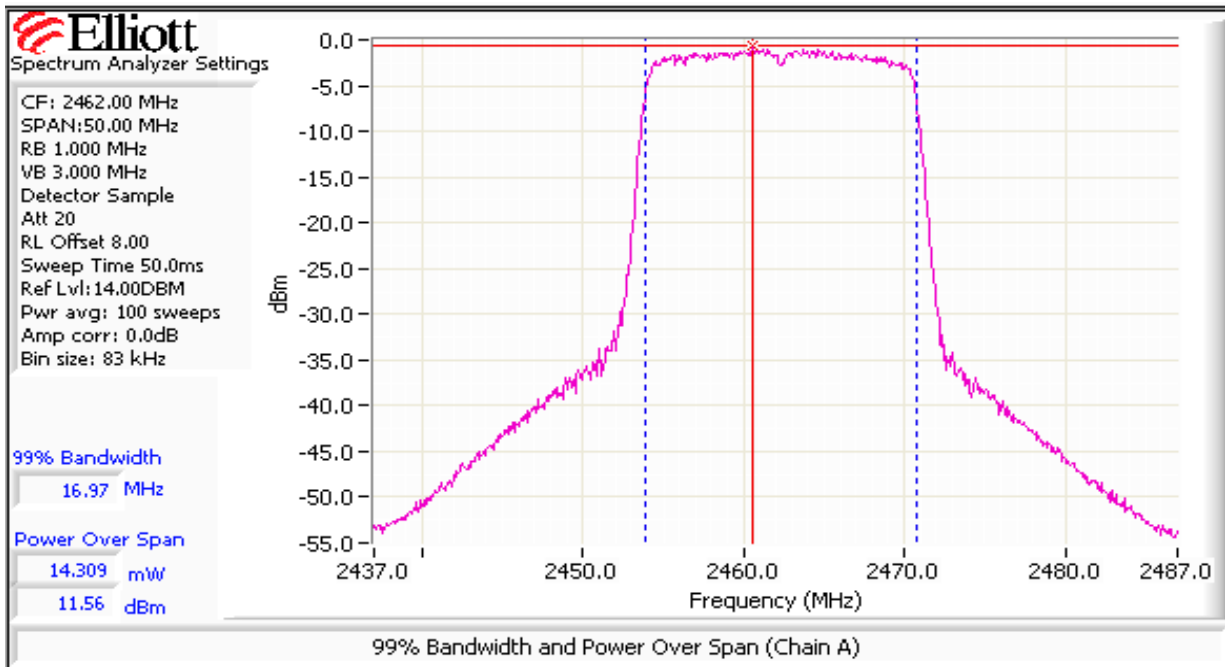
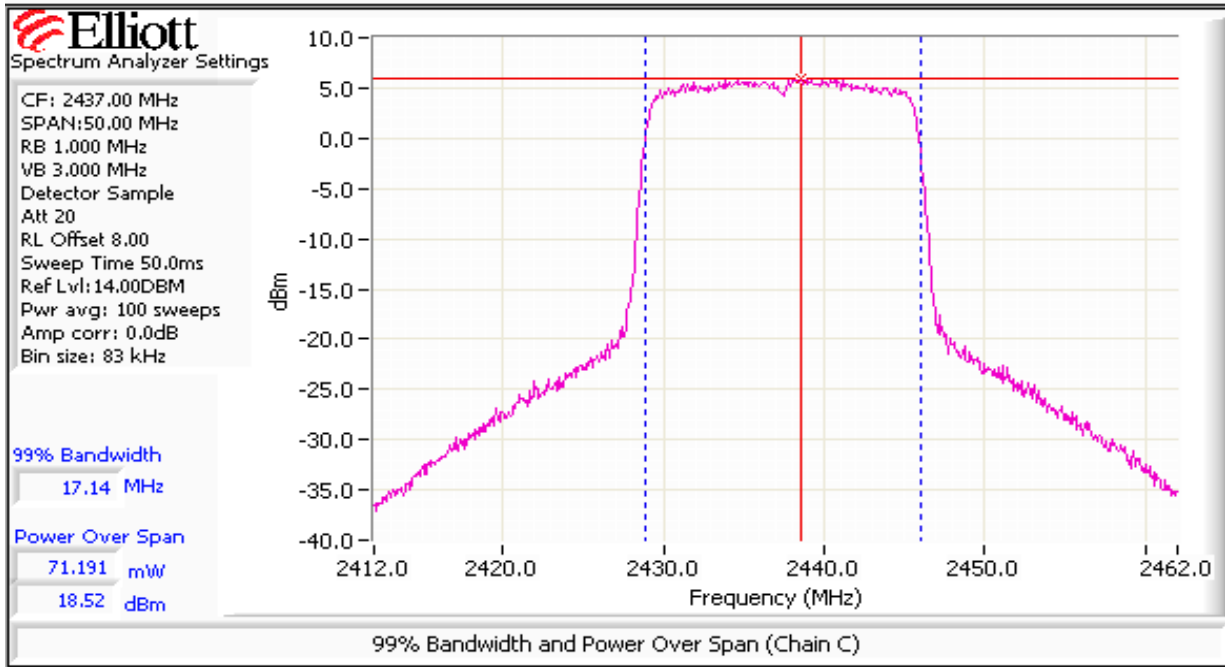

Client: Xirrus	Job Number: J71456
Model: XN-16 and XN-8	T-Log Number: T71643
Contact: Steve Smith	Account Manager: Susan Pezli
Standard: -	Class: N/A

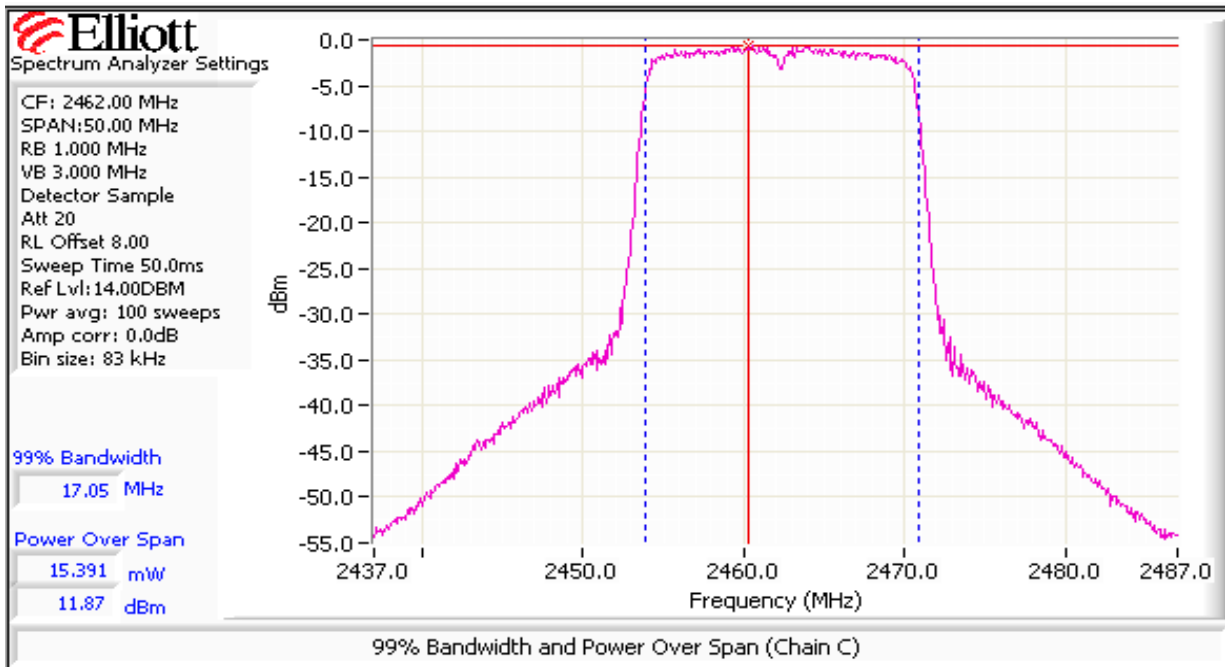
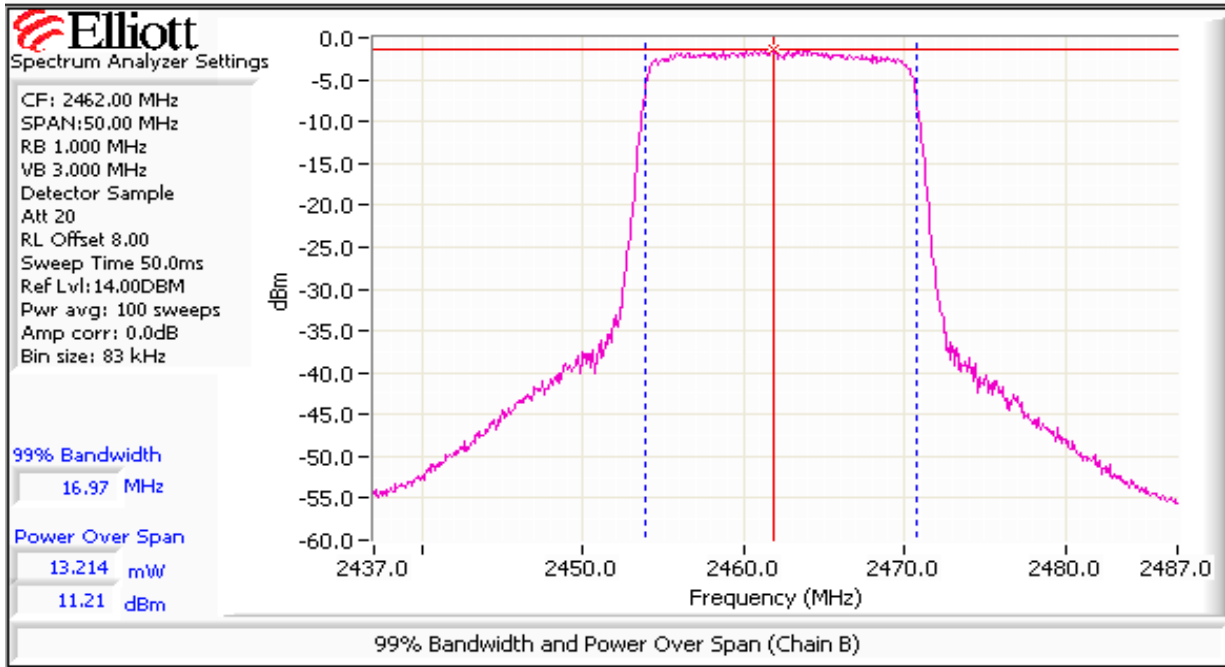

Client: Xirrus	Job Number: J71456
Model: XN-16 and XN-8	T-Log Number: T71643
	Account Manager: Susan Pezli
Contact: Steve Smith	
Standard: -	Class: N/A

Run #2: Power spectral Density

Power Setting	Frequency (MHz)	PSD (dBm/3kHz) ^{Note 1}				Total	Limit dBm/3kHz	Result
		Chain 1	Chain 2	Chain 3	Chain 4			
17.5	2412 802.11b	-6.5	-5.5	-6.8		-1.5	8.0	Pass
20.0	2437 802.11b	-2.3	-0.5	-2.2		3.2	8.0	Pass
17.5	2462 802.11b	-5.6	-3.8	-5.2		0.0	8.0	Pass
14.5	2412 802.11g	-9.9	-1.4	-3.7		1.0	8.0	Pass
20.0	2437 802.11g	-1.0	3.2	-0.9		5.7	8.0	Pass
13.5	2462 802.11g	-8.2	-5.1	-9.6		-2.4	8.0	Pass

Note 1:	Power spectral density measured using RB=3 kHz, VB=10kHz, analyzer with peak detector and with a sweep time set to ensure a dwell time of at least 1 second per 3kHz. The measurement is made at the frequency of PPSD determined from preliminary scans using RB=3kHz using multiple sweeps at a faster rate over the 6dB bandwidth of the signal.
Note 2:	The operation of multiple radios in the band does not affect power spectral density as radios cannot operate on overlapping channels.

Client: Xirrus	Job Number: J71456
Model: XN-16 and XN-8	T-Log Number: T71643
Contact: Steve Smith	Account Manager: Susan Pezli
Standard: -	Class: N/A

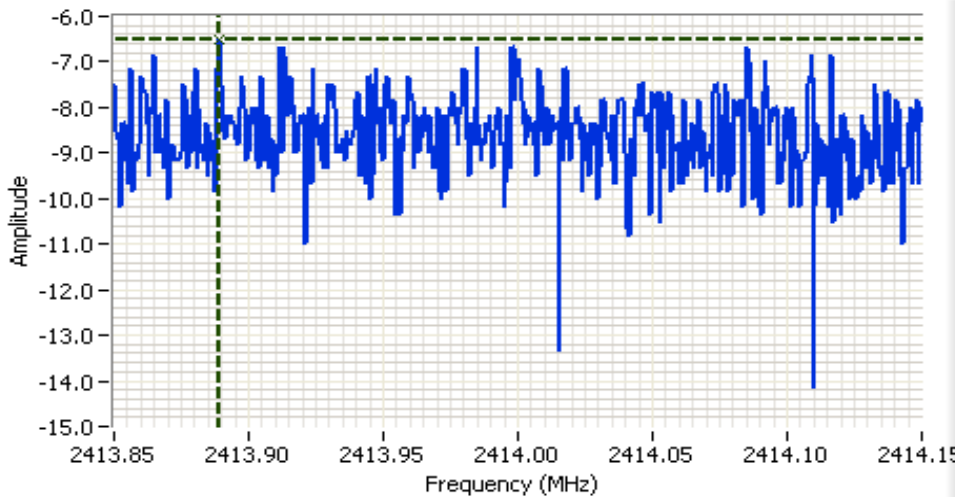

Analyzer Settings
 HP8564E,006,EMI,UK6
 CF: 2414.000 MHz
 SPAN:300 kHz
 RB 3.00 kHz
 VB 10.00 kHz
 Detector POS
 Att 10
 RL Offset 8.00
 Sweep Time 100.0s
 Ref Lvl:-2.00DBM

Comments
 PSD: -6.5 dBm/3kHz
 802.11b MIMO
 Chain A

Cursor 1 2413.8890 -6.50

0.0000 0.00

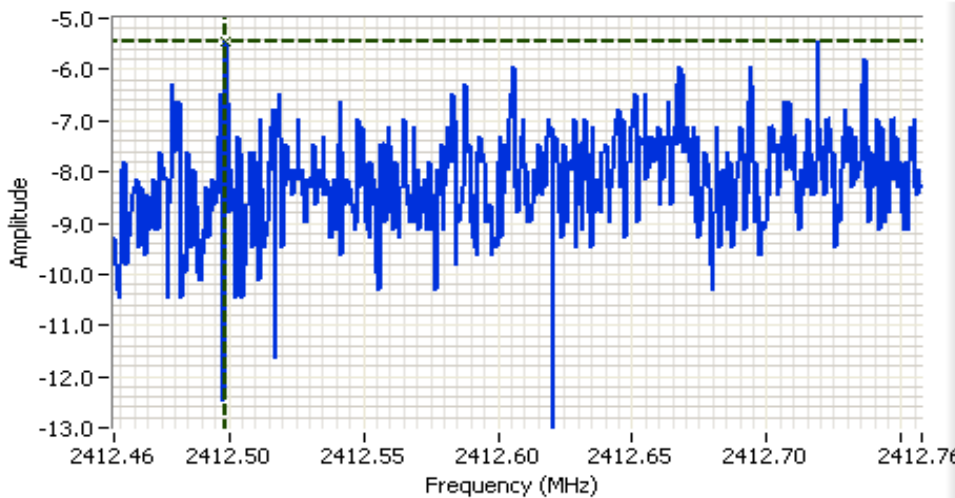

Analyzer Settings
 HP8564E,006,EMI,UK6
 CF: 2412.607 MHz
 SPAN:300 kHz
 RB 3.00 kHz
 VB 10.00 kHz
 Detector POS
 Att 10
 RL Offset 8.00
 Sweep Time 100.0s
 Ref Lvl:-1.80DBM

Comments
 PSD: -5.5 dBm/3kHz
 802.11b MIMO
 Chain B

Cursor 1 2412.4989 -5.47

0.0000 0.00



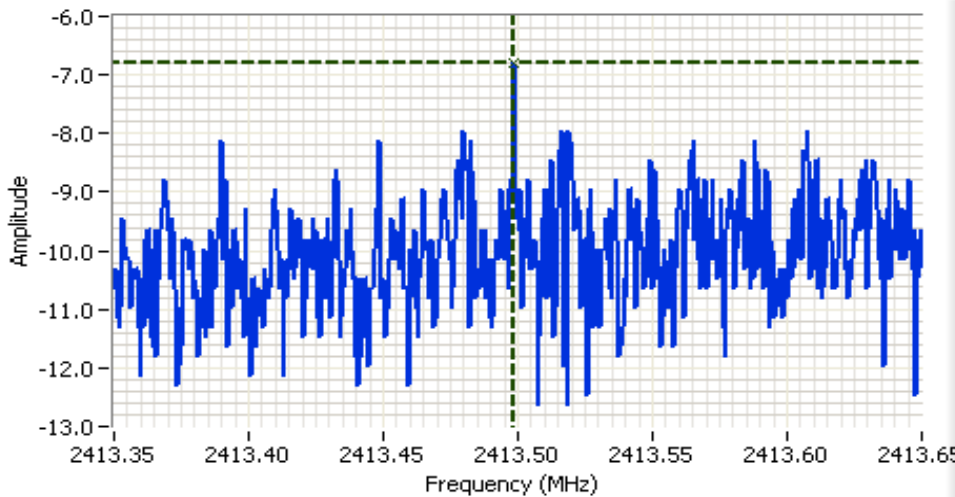

Client: Xirrus	Job Number: J71456
Model: XN-16 and XN-8	T-Log Number: T71643
Contact: Steve Smith	Account Manager: Susan Pezli
Standard: -	Class: N/A



Analyzer Settings
 HP8564E,006,EMI,UK6
 CF: 2413.500 MHz
 SPAN:300 kHz
 RB 3.00 kHz
 VB 10.00 kHz
 Detector POS
 Att 10
 RL Offset 8.00
 Sweep Time 100.0s
 Ref Lvl:-5.30DBM

Comments
 PSD: -6.8 dBm/3kHz
 802.11b MIMO
 Chain C

Cursor 1 2413.4985 -6.80 

0.0000 0.00 

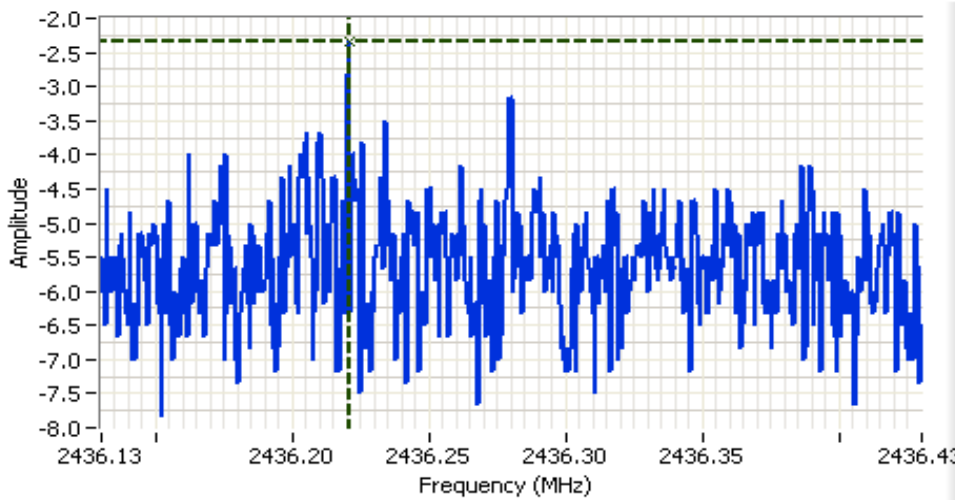

Analyzer Settings
 HP8564E,006,EMI,UK6
 CF: 2436.280 MHz
 SPAN:300 kHz
 RB 3.00 kHz
 VB 10.00 kHz
 Detector POS
 Att 10
 RL Offset 8.00
 Sweep Time 100.0s
 Ref Lvl:0.50DBM

Comments
 PSD: -2.3 dBm/3kHz
 802.11b MIMO
 Chain A

Cursor 1 2436.2205 -2.33 

0.0000 0.00 



Client: Xirrus	Job Number: J71456
Model: XN-16 and XN-8	T-Log Number: T71643
Contact: Steve Smith	Account Manager: Susan Pezli
Standard: -	Class: N/A

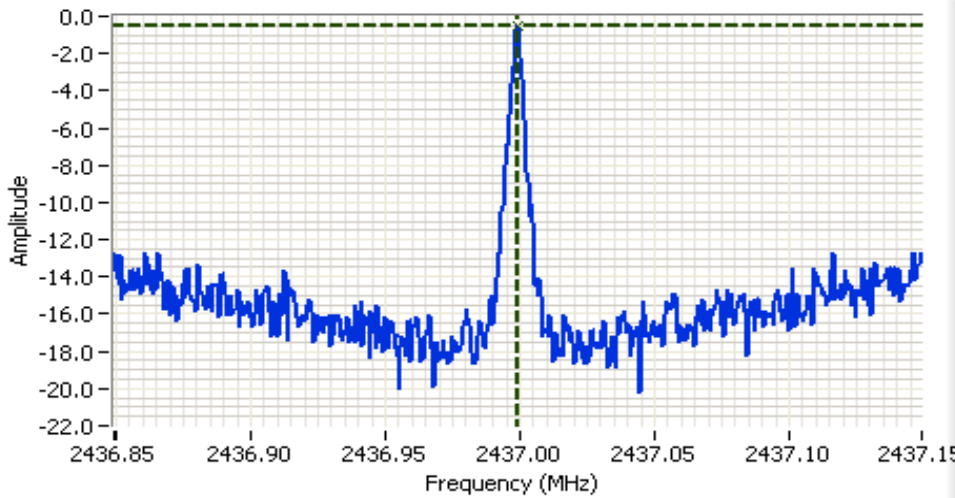

Analyzer Settings
 HP8564E,006,EMI,UK6
 CF: 2436.999 MHz
 SPAN:300 kHz
 RB 3.00 kHz
 VB 10.00 kHz
 Detector POS
 Att 10
 RL Offset 8.00
 Sweep Time 100.0s
 Ref Lvl:4.30DBM

Comments
 PSD: -0.5 dBm/3kHz
 802.11b MIMO
 Chain B

Cursor 1 2436.9993 -0.53 [Icons]
 0.0000 0.00 [Icons]

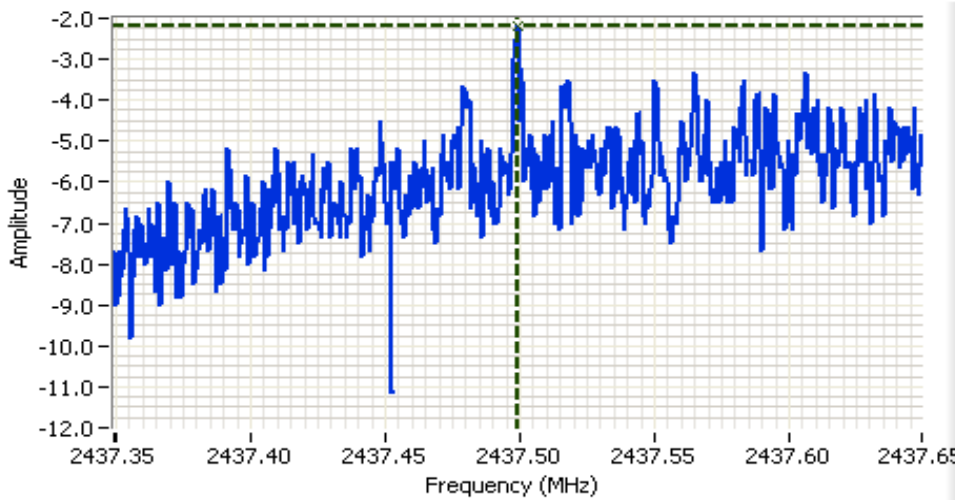

Analyzer Settings
 HP8564E,006,EMI,UK6
 CF: 2437.499 MHz
 SPAN:300 kHz
 RB 3.00 kHz
 VB 10.00 kHz
 Detector POS
 Att 10
 RL Offset 8.00
 Sweep Time 100.0s
 Ref Lvl:0.50DBM

Comments
 PSD: -2.2 dBm/3kHz
 802.11b MIMO
 Chain C

Cursor 1 2437.4993 -2.17 [Icons]
 0.0000 0.00 [Icons]



Client: Xirus	Job Number: J71456
Model: XN-16 and XN-8	T-Log Number: T71643
Contact: Steve Smith	Account Manager: Susan Pezli
Standard: -	Class: N/A

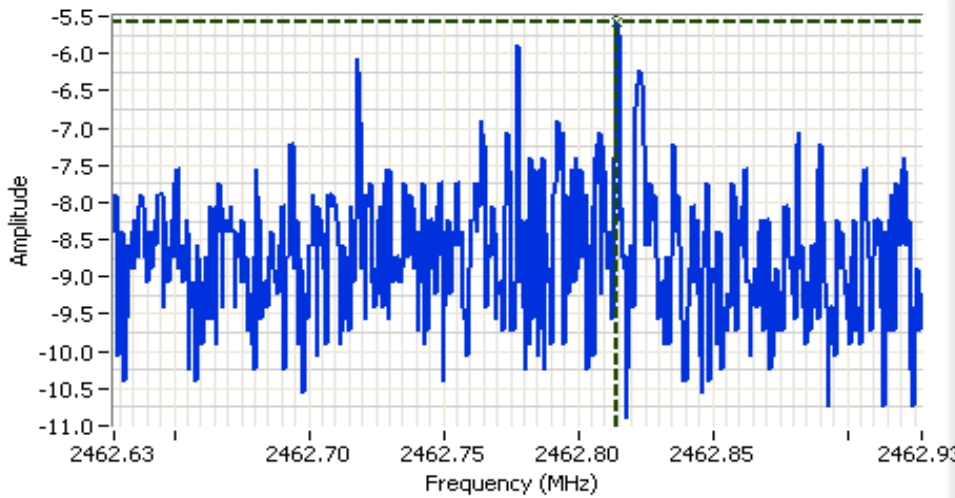

Analyzer Settings
 HP8564E,006,EMI,UK6
 CF: 2462.778 MHz
 SPAN:300 kHz
 RB 3.00 kHz
 VB 10.00 kHz
 Detector POS
 Att 10
 RL Offset 8.00
 Sweep Time 100.0s
 Ref Lvl:-0.40DBM

Comments
 PSD: -5.6 dBm/3kHz
 802.11b MIMO
 Chain A

Cursor 1 2462.8141 -5.57

0.0000 0.00

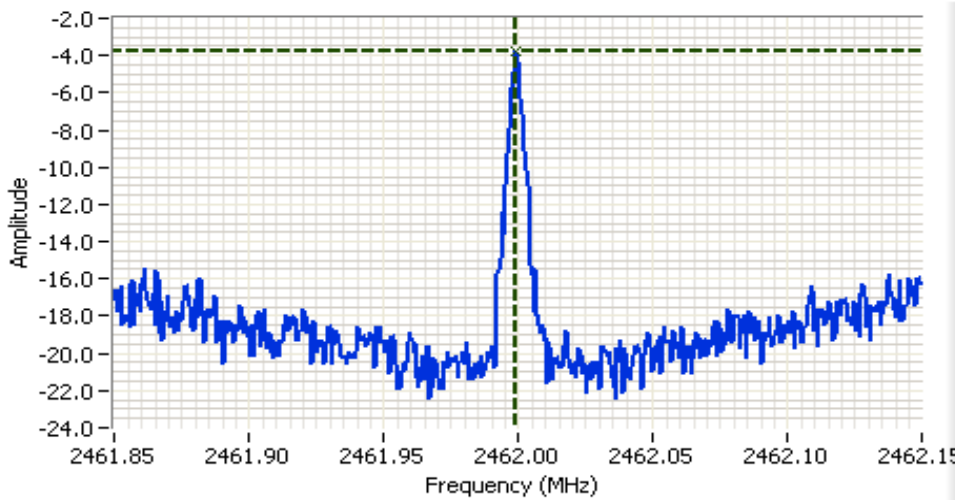

Analyzer Settings
 HP8564E,006,EMI,UK6
 CF: 2462.000 MHz
 SPAN:300 kHz
 RB 3.00 kHz
 VB 10.00 kHz
 Detector POS
 Att 10
 RL Offset 8.00
 Sweep Time 100.0s
 Ref Lvl:1.40DBM

Comments
 PSD: -3.8 dBm/3kHz
 802.11b MIMO
 Chain B

Cursor 1 2461.9993 -3.77

0.0000 0.00



Client: Xirus	Job Number: J71456
Model: XN-16 and XN-8	T-Log Number: T71643
Contact: Steve Smith	Account Manager: Susan Pezli
Standard: -	Class: N/A

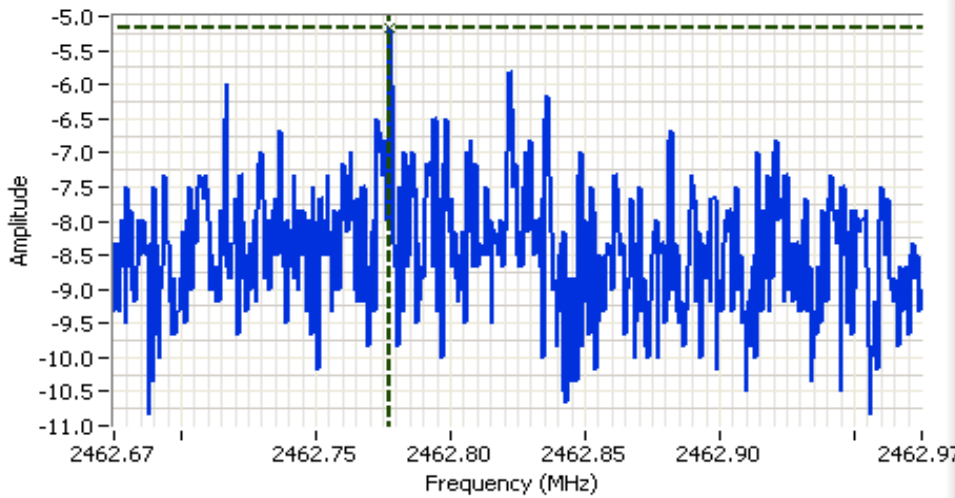

Analyzer Settings
 HP8564E,006,EMI,UK6
 CF: 2462.825 MHz
 SPAN:300 kHz
 RB 3.00 kHz
 VB 10.00 kHz
 Detector POS
 Att 10
 RL Offset 8.00
 Sweep Time 100.0s
 Ref Lvl:-1.00DBM

Comments
 PSD: -5.2 dBm/3kHz
 802.11b MIMO
 Chain C

Cursor 1 2462.7775 -5.17

0.0000 0.00

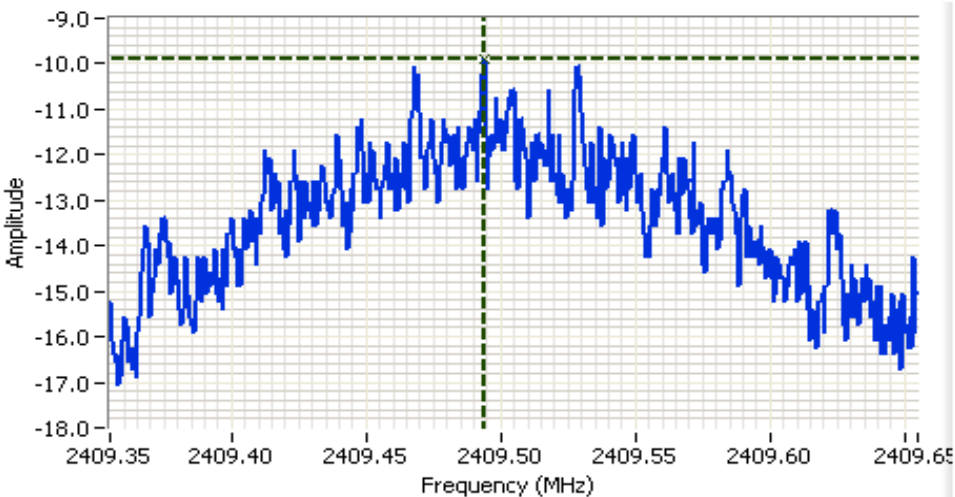

Analyzer Settings
 HP8564E,006,EMI,UK6
 CF: 2409.505 MHz
 SPAN:300 kHz
 RB 3.00 kHz
 VB 10.00 kHz
 Detector POS
 Att 10
 RL Offset 8.00
 Sweep Time 100.0s
 Ref Lvl:-7.40DBM

Comments
 PSD: -9.9 dBm/3kHz
 802.11g MIMO
 Chain A

Cursor 1 2409.4939 -9.90

0.0000 0.00



Client: Xirrus	Job Number: J71456
Model: XN-16 and XN-8	T-Log Number: T71643
Contact: Steve Smith	Account Manager: Susan Pezli
Standard: -	Class: N/A

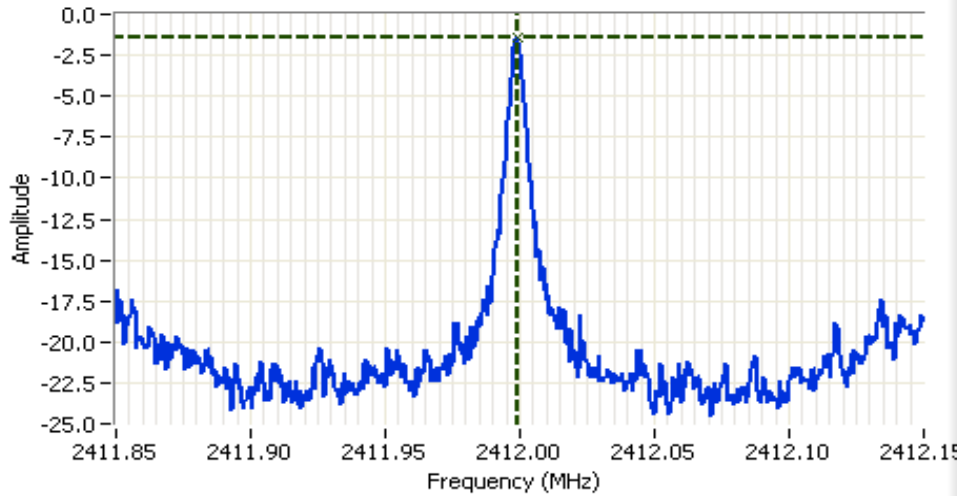

Analyzer Settings
 HP8564E,006,EMI,UK6
 CF: 2412.000 MHz
 SPAN:300 kHz
 RB 3.00 kHz
 VB 10.00 kHz
 Detector POS
 Att 10
 RL Offset 8.00
 Sweep Time 100.0s
 Ref Lvl:0.30DBM

Comments
 PSD: -1.4 dBm/3kHz
 802.11g MIMO
 Chain B

Cursor 1 2411.9990 -1.37

0.0000 0.00

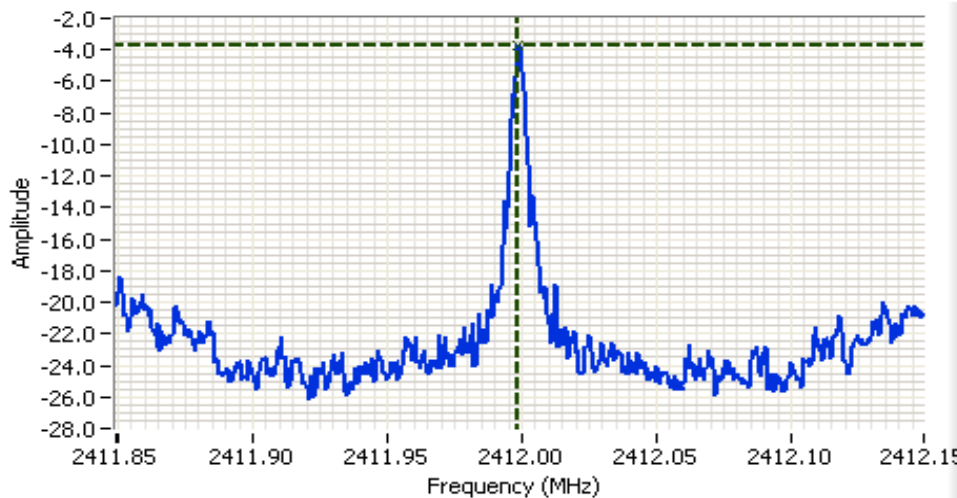

Analyzer Settings
 HP8564E,006,EMI,UK6
 CF: 2411.999 MHz
 SPAN:300 kHz
 RB 3.00 kHz
 VB 10.00 kHz
 Detector POS
 Att 10
 RL Offset 8.00
 Sweep Time 100.0s
 Ref Lvl:-2.70DBM

Comments
 PSD: -3.7 dBm/3kHz
 802.11g MIMO
 Chain C

Cursor 1 2411.9988 -3.70

0.0000 0.00



Client: Xirrus	Job Number: J71456
Model: XN-16 and XN-8	T-Log Number: T71643
Contact: Steve Smith	Account Manager: Susan Pezli
Standard: -	Class: N/A

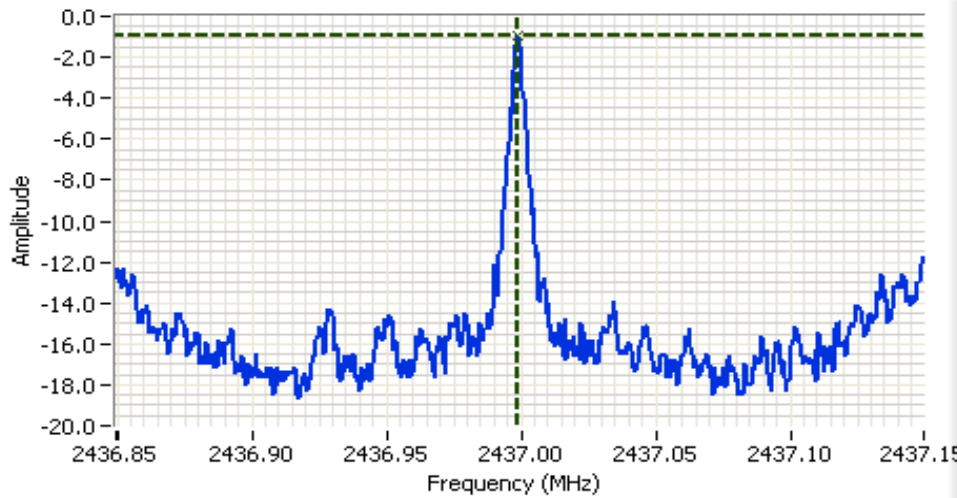

Analyzer Settings

HP8564E,006,EMI,UK6
 CF: 2437.000 MHz
 SPAN:300 kHz
 RB 3.00 kHz
 VB 10.00 kHz
 Detector POS
 Att 10
 RL Offset 8.00
 Sweep Time 100.0s
 Ref Lvl:2.70DBM

Comments

PSD: -1.0 dBm/3kHz
 802.11g MIMO
 Chain A

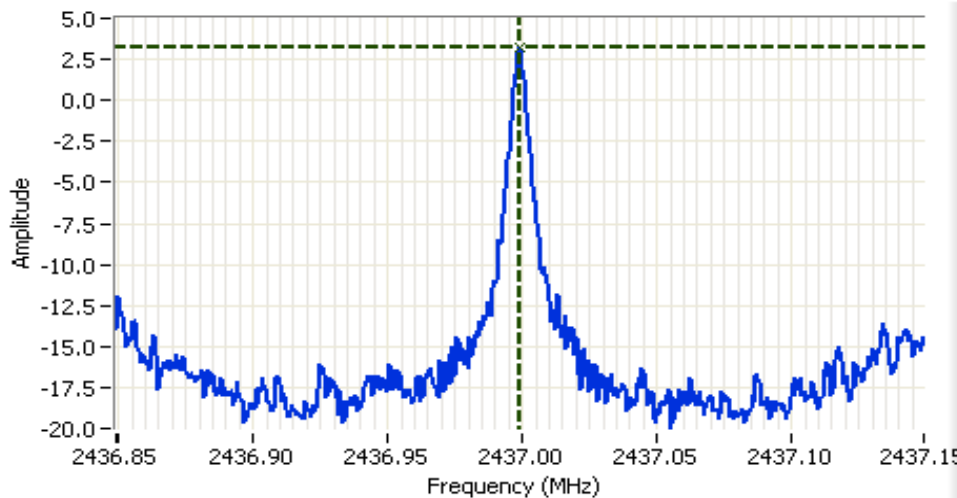
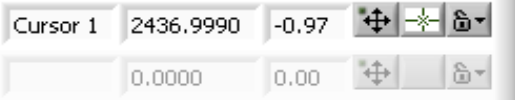

Analyzer Settings

HP8564E,006,EMI,UK6
 CF: 2436.999 MHz
 SPAN:300 kHz
 RB 3.00 kHz
 VB 10.00 kHz
 Detector POS
 Att 10
 RL Offset 8.00
 Sweep Time 100.0s
 Ref Lvl:6.20DBM

Comments

PSD: 3.2 dBm/3kHz
 802.11g MIMO
 Chain B

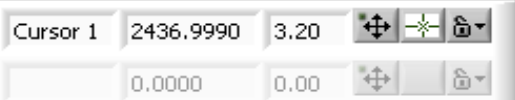

Client: Xirus	Job Number: J71456
Model: XN-16 and XN-8	T-Log Number: T71643
Contact: Steve Smith	Account Manager: Susan Pezli
Standard: -	Class: N/A

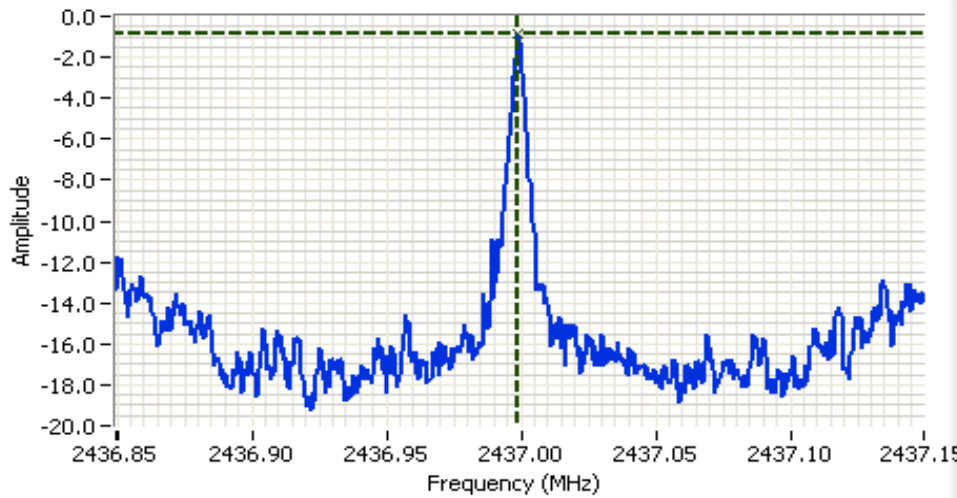

Analyzer Settings
 HP8564E,006,EMI,UK6
 CF: 2437.000 MHz
 SPAN:300 kHz
 RB 3.00 kHz
 VB 10.00 kHz
 Detector POS
 Att 10
 RL Offset 8.00
 Sweep Time 100.0s
 Ref Lvl:1.60DBM

Comments
 PSD: -0.9 dBm/3kHz
 802.11g MIMO
 Chain C

Cursor 1 2436.9990 -0.90 [Icons]
 0.0000 0.00 [Icons]

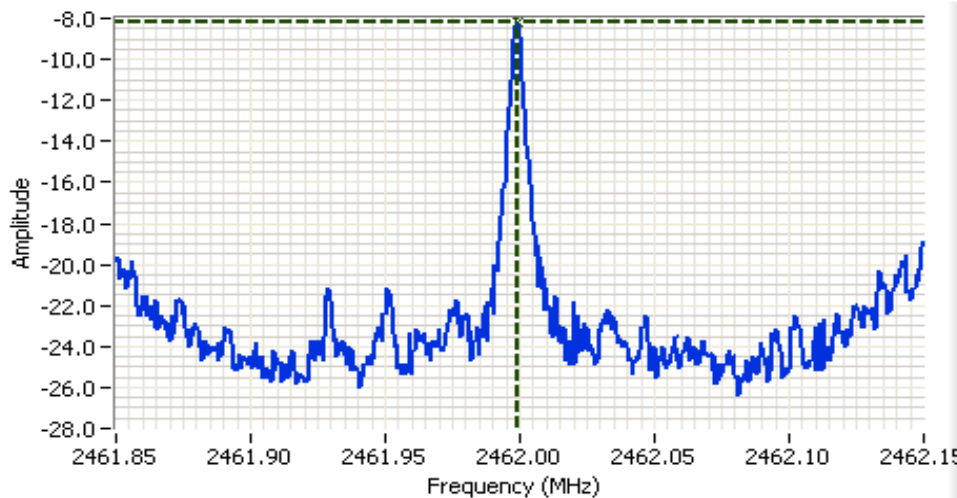

Analyzer Settings
 HP8564E,006,EMI,UK6
 CF: 2462.000 MHz
 SPAN:300 kHz
 RB 3.00 kHz
 VB 10.00 kHz
 Detector POS
 Att 10
 RL Offset 8.00
 Sweep Time 100.0s
 Ref Lvl:-5.70DBM

Comments
 PSD: -8.2 dBm/3kHz
 802.11g MIMO
 Chain A

Cursor 1 2461.9990 -8.20 [Icons]
 0.0000 0.00 [Icons]



Client: Xirus	Job Number: J71456
Model: XN-16 and XN-8	T-Log Number: T71643
Contact: Steve Smith	Account Manager: Susan Pezli
Standard: -	Class: N/A

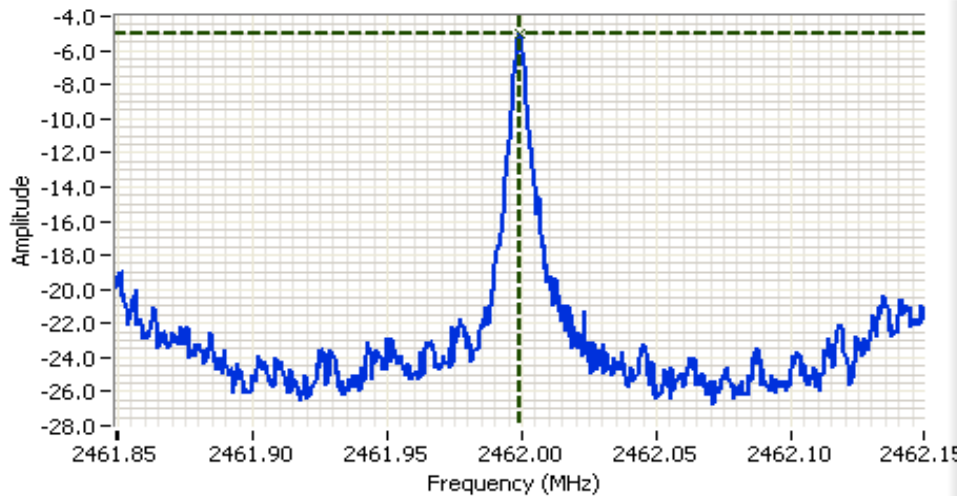

Analyzer Settings
 HP8564E,006,EMI,UK6
 CF: 2461.999 MHz
 SPAN:300 kHz
 RB 3.00 kHz
 VB 10.00 kHz
 Detector POS
 Att 10
 RL Offset 8.00
 Sweep Time 100.0s
 Ref Lvl:-1.40DBM

Comments
 PSD: -5.1 dBm/3kHz
 802.11g MIMO
 Chain B

Cursor 1 2461.9993 -5.07 [Icons]
 0.0000 0.00 [Icons]

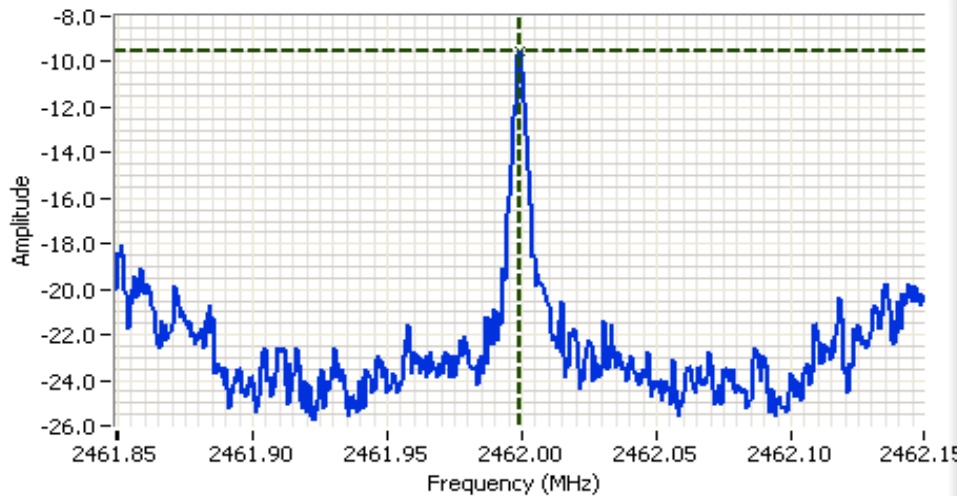

Analyzer Settings
 HP8564E,006,EMI,UK6
 CF: 2461.999 MHz
 SPAN:300 kHz
 RB 3.00 kHz
 VB 10.00 kHz
 Detector POS
 Att 10
 RL Offset 8.00
 Sweep Time 100.0s
 Ref Lvl:-8.90DBM

Comments
 PSD: -9.6 dBm/3kHz
 802.11g MIMO
 Chain C

Cursor 1 2461.9993 -9.57 [Icons]
 0.0000 0.00 [Icons]



Client: Xirrus	Job Number: J71456
Model: XN-16 and XN-8	T-Log Number: T71643
	Account Manager: Susan Pezli
Contact: Steve Smith	
Standard: -	Class: N/A

Run #3: Signal Bandwidth

Power Setting	Frequency (MHz)	Resolution Bandwidth	Bandwidth (MHz)	
			6dB	99%
17.5	2412 802.11b	100kHz	9.6	15.8
20.0	2437 802.11b	100kHz	9.9	15.8
17.5	2462 802.11b	100kHz	9.7	15.7
14.5	2412 802.11g	100kHz	16.5	17.1
20.0	2437 802.11g	100kHz	16.4	17.1
13.5	2462 802.11g	100kHz	16.5	17.1

Note 1: Measured on each chain

Note 2: 99% bandwidth measured in accordance with RSS GEN, with RB > 1% of the span and VB > 3xRB

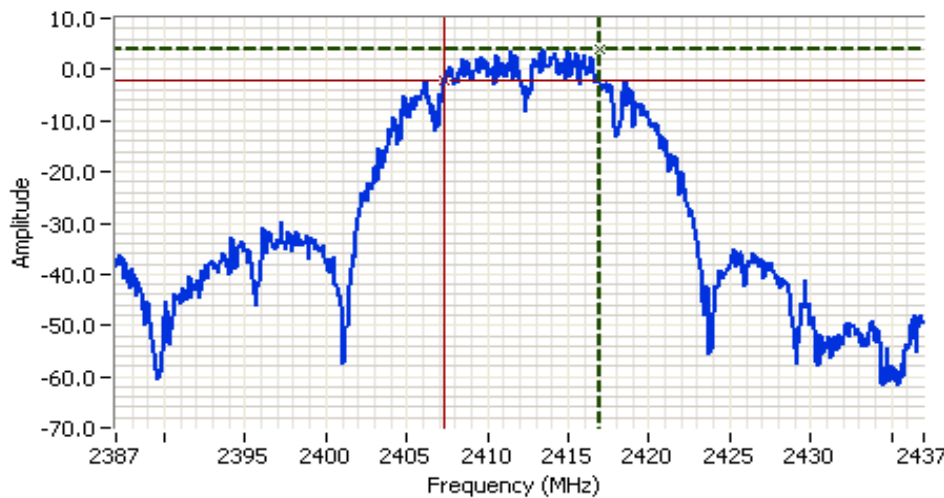

Analyzer Settings

HP8564E,006,EMI,UK6
 CF: 2412.000 MHz
 SPAN:50.000 MHz
 RB 100 kHz
 VB 100 kHz
 Detector POS
 Att 10
 RL Offset 8.00
 Sweep Time 50.0ms
 Ref Lvl:7.70DBM

Comments

6dB BW: 9.583 MHz
 802.11b MIMO
 Chain B

Cursor 1	2416.9167	3.87	↕	⊗	🔒
Cursor 2	2407.3333	-2.13	↕	⊗	🔒

Delta Freq. 9.583
 Delta Amplitude 6.00



Client: Xirus	Job Number: J71456
Model: XN-16 and XN-8	T-Log Number: T71643
Contact: Steve Smith	Account Manager: Susan Pezli
Standard: -	Class: N/A

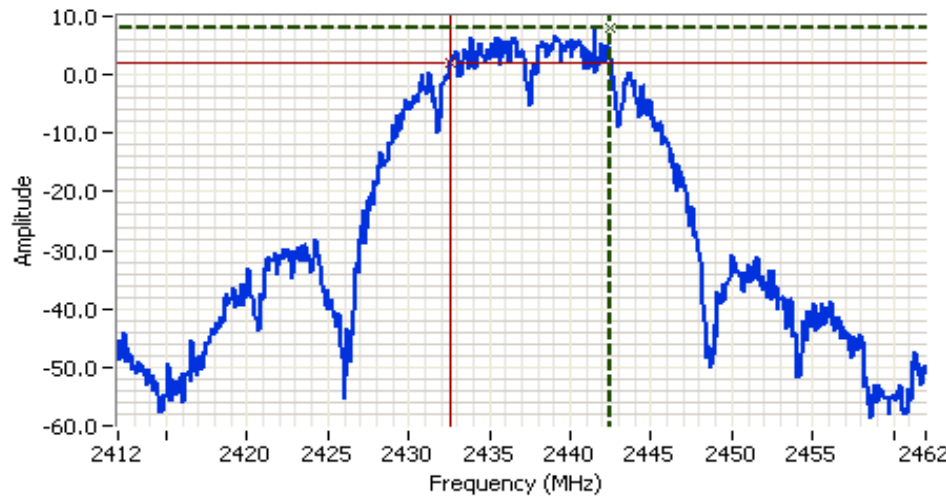

Analyzer Settings
 HP8564E,006,EMI,UK6
 CF: 2437.000 MHz
 SPAN:50.000 MHz
 RB 100 kHz
 VB 100 kHz
 Detector POS
 Att 20
 RL Offset 8.00
 Sweep Time 50.0ms
 Ref Lvl:10.50DBM

Comments
 6dB BW: 9.917 MHz
 802.11b MIMO
 Chain A

Cursor 1 2442.5000 8.17 Delta Freq. 9.917
 Cursor 2 2432.5833 2.17 Delta Amplitude 6.00

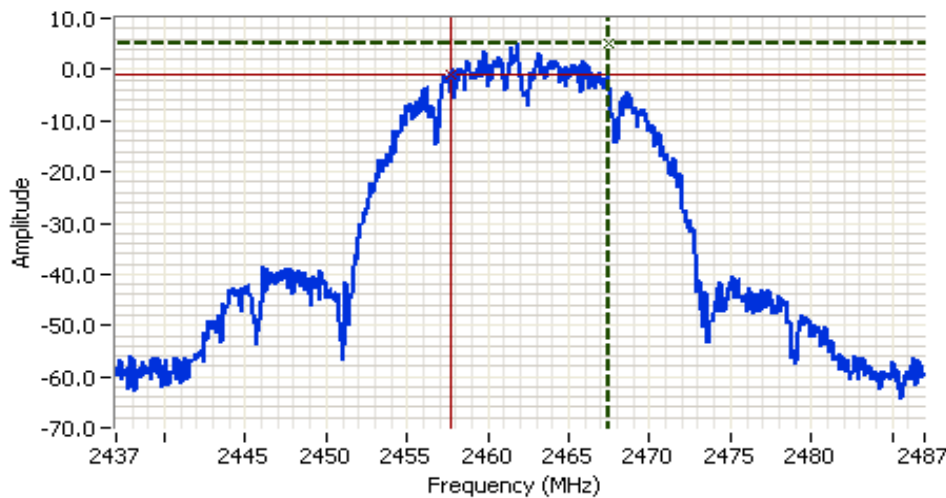

Analyzer Settings
 HP8564E,006,EMI,UK6
 CF: 2462.000 MHz
 SPAN:50.000 MHz
 RB 100 kHz
 VB 100 kHz
 Detector POS
 Att 20
 RL Offset 8.00
 Sweep Time 50.0ms
 Ref Lvl:10.50DBM

Comments
 6dB BW: 9.667 MHz
 802.11b MIMO
 Chain B

Cursor 1 2467.4167 5.00 Delta Freq. 9.667
 Cursor 2 2457.7500 -1.00 Delta Amplitude 6.00



Client: Xirrus	Job Number: J71456
Model: XN-16 and XN-8	T-Log Number: T71643
Contact: Steve Smith	Account Manager: Susan Pezli
Standard: -	Class: N/A

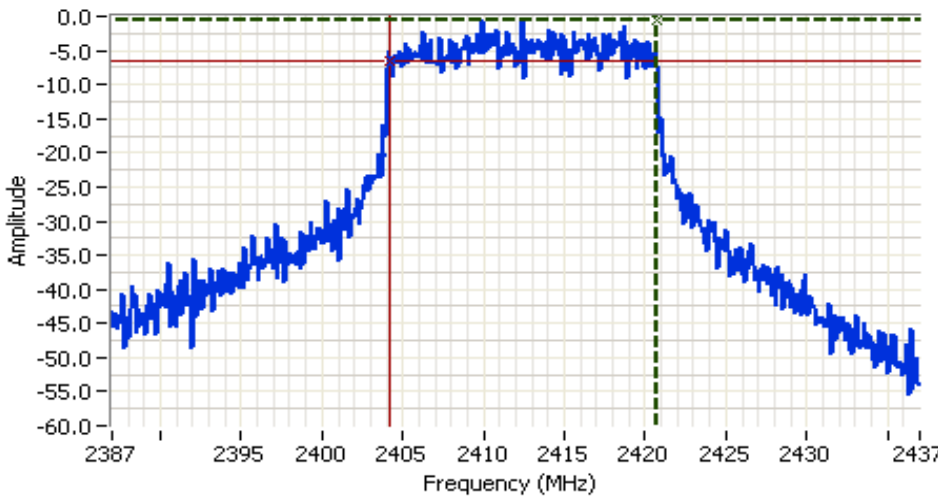

Analyzer Settings
 HP8564E,006,EMI,UK6
 CF: 2412.000 MHz
 SPAN:50.000 MHz
 RB 100 kHz
 VB 100 kHz
 Detector POS
 Att 10
 RL Offset 8.00
 Sweep Time 50.0ms
 Ref Lvl:2.80DBM

Comments
 6dB BW: 16.500 MHz
 802.11g MIMO
 Chain B

Cursor 1	2420.6667	-0.53	
Cursor 2	2404.1667	-6.53	

Delta Freq. 16.500
 Delta Amplitude 6.00

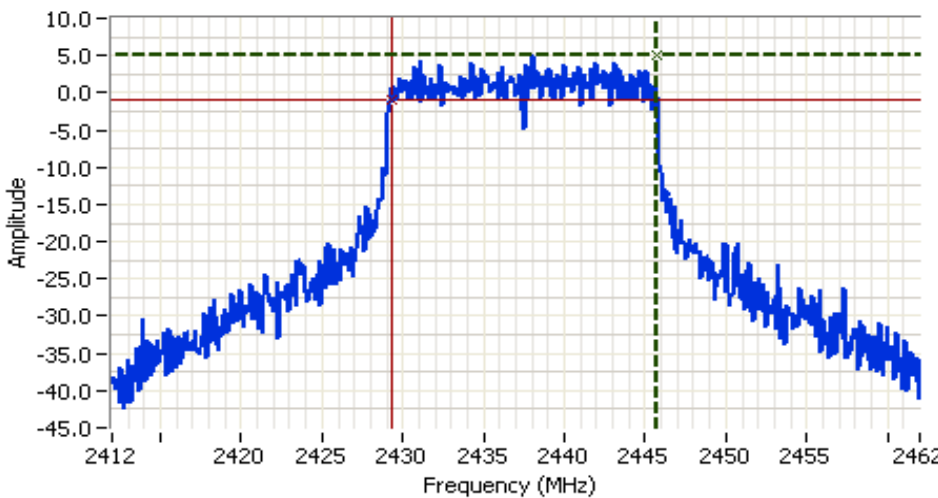

Analyzer Settings
 HP8564E,006,EMI,UK6
 CF: 2437.000 MHz
 SPAN:50.000 MHz
 RB 100 kHz
 VB 100 kHz
 Detector POS
 Att 20
 RL Offset 8.00
 Sweep Time 50.0ms
 Ref Lvl:10.50DBM

Comments
 6dB BW: 16.417 MHz
 802.11g MIMO
 Chain A

Cursor 1	2445.7500	5.17	
Cursor 2	2429.3333	-0.83	

Delta Freq. 16.417
 Delta Amplitude 6.00



Client: Xirrus	Job Number: J71456
Model: XN-16 and XN-8	T-Log Number: T71643
	Account Manager: Susan Pezli
Contact: Steve Smith	
Standard: -	Class: N/A

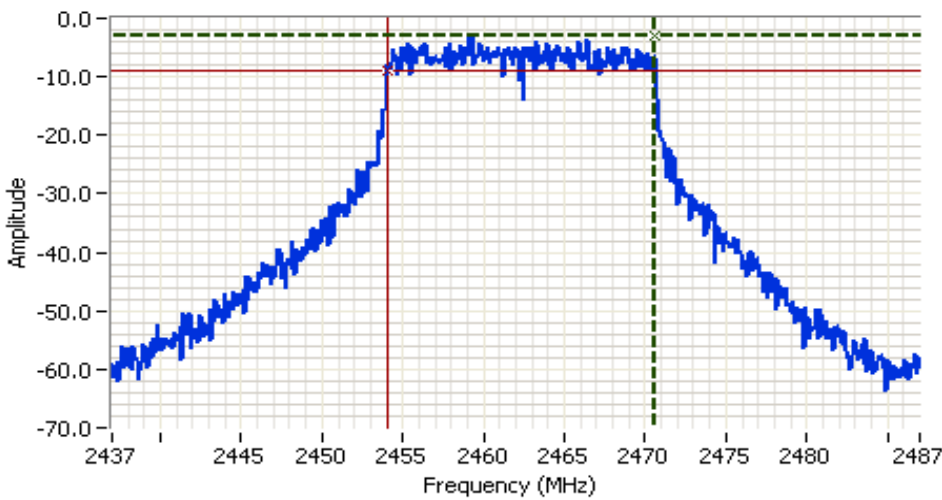

Analyzer Settings

HP8564E,006,EMI,UK6
 CF: 2462.000 MHz
 SPAN:50.000 MHz
 RB 100 kHz
 VB 100 kHz
 Detector POS
 Att 10
 RL Offset 8.00
 Sweep Time 50.0ms
 Ref Lvl:2.80DBM

Comments

6dB BW: 16.500 MHz
 802.11g MIMO
 Chain B

Cursor 1 2470.5833 -3.03

Cursor 2 2454.0833 -9.03

Delta Freq. 16.500

Delta Amplitude 6.00



Run #4: Out of Band Spurious Emissions

Power Setting Per Chain				Frequency (MHz)	Limit	Result
#1	#2	#3	#4			
17.5	17.5	17.5		2412 802.11b	-30dBc	Pass
20.0	20.0	20.0		2437 802.11b	-30dBc	Pass
17.5	17.5	17.5		2462 802.11b	-30dBc	Pass
14.5	14.5	14.5		2412 802.11g	-30dBc	Pass
20.0	20.0	20.0		2437 802.11g	-30dBc	Pass
13.5	13.5	13.5		2462 802.11g	-30dBc	Pass

Note 1: Measured with all chains connected together through a combiner, unused ports on the combiner terminated in 50ohms.
 Note 2: Measured using RB>=100kHz, VB>= RB

Client: Xirrus	Job Number: J71456
Model: XN-16 and XN-8	T-Log Number: T71643
	Account Manager: Susan Pezli
Contact: Steve Smith	
Standard: -	Class: N/A

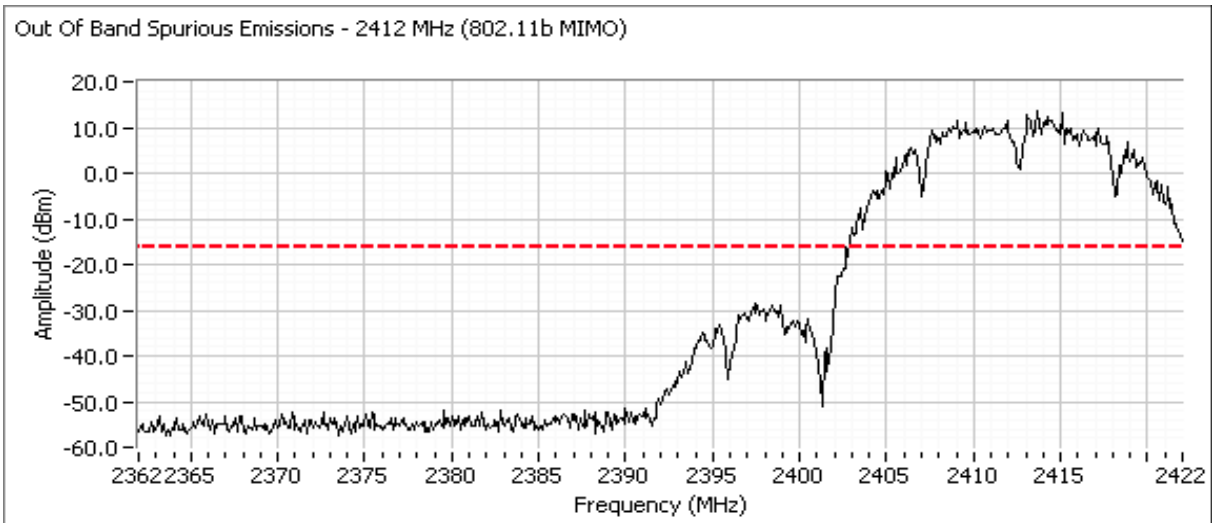
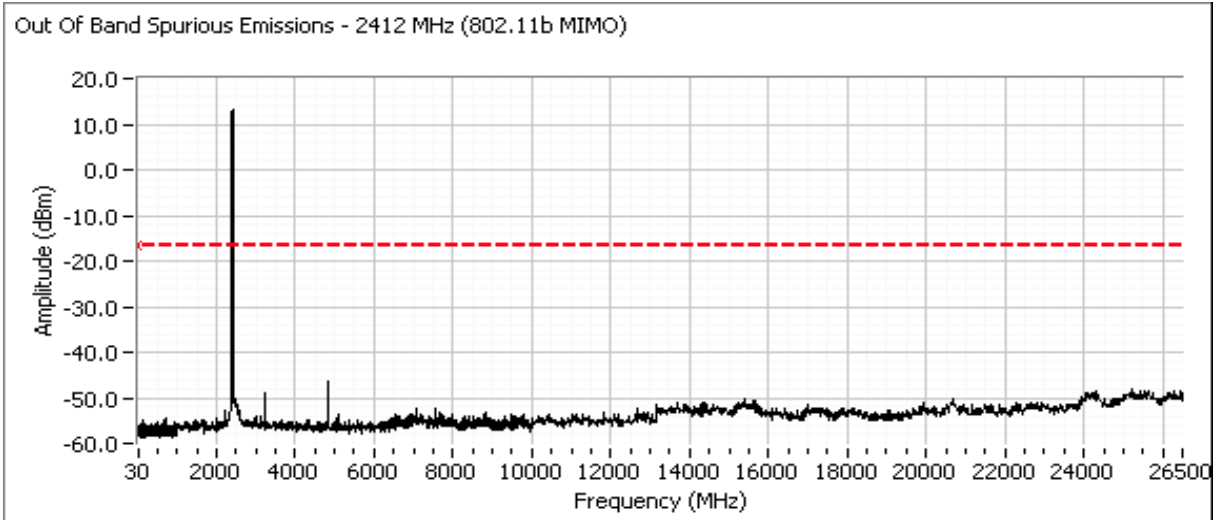
Plots for low channel - 802.11b -, power setting(s) = 17.5



Client: Xirrus	Job Number: J71456
Model: XN-16 and XN-8	T-Log Number: T71643
	Account Manager: Susan Pezli
Contact: Steve Smith	
Standard: -	Class: N/A

Plots for center channel - 802.11b - , power setting(s) = 20.0

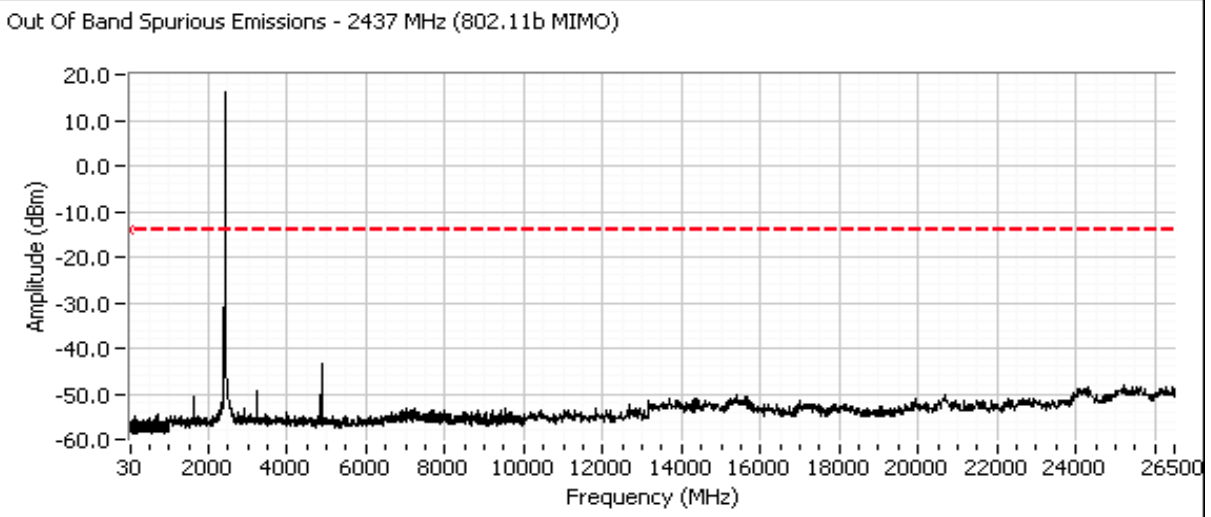

Plots for high channel - 802.11b - , power setting(s) = 17.5

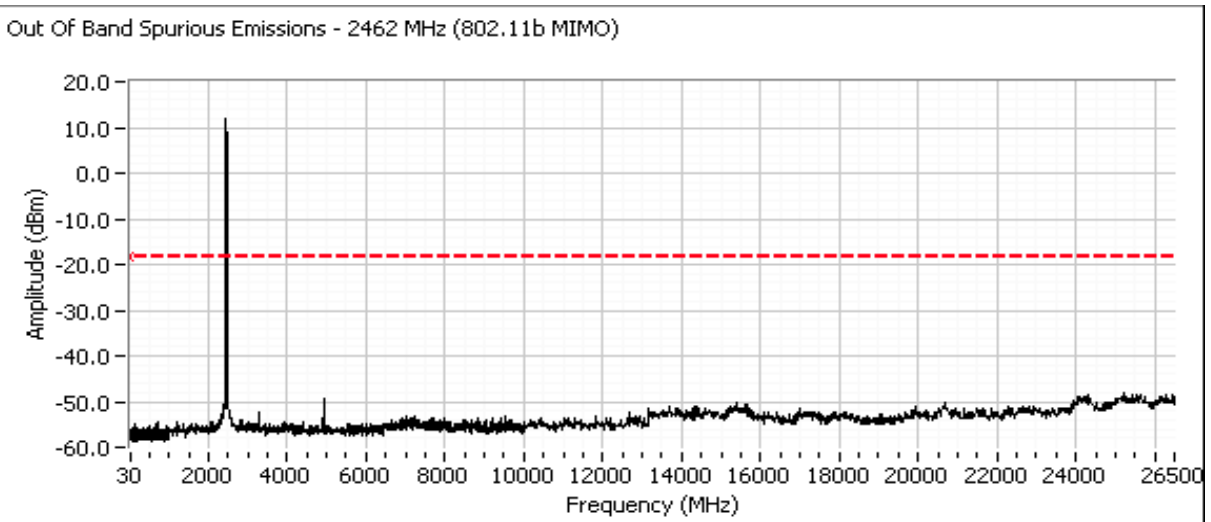

Client: Xirrus	Job Number: J71456
Model: XN-16 and XN-8	T-Log Number: T71643
	Account Manager: Susan Pezli
Contact: Steve Smith	
Standard: -	Class: N/A

Plots for low channel - 802.11g - , power setting(s) = 14.5

Out Of Band Spurious Emissions - 2412 MHz (802.11g MIMO)

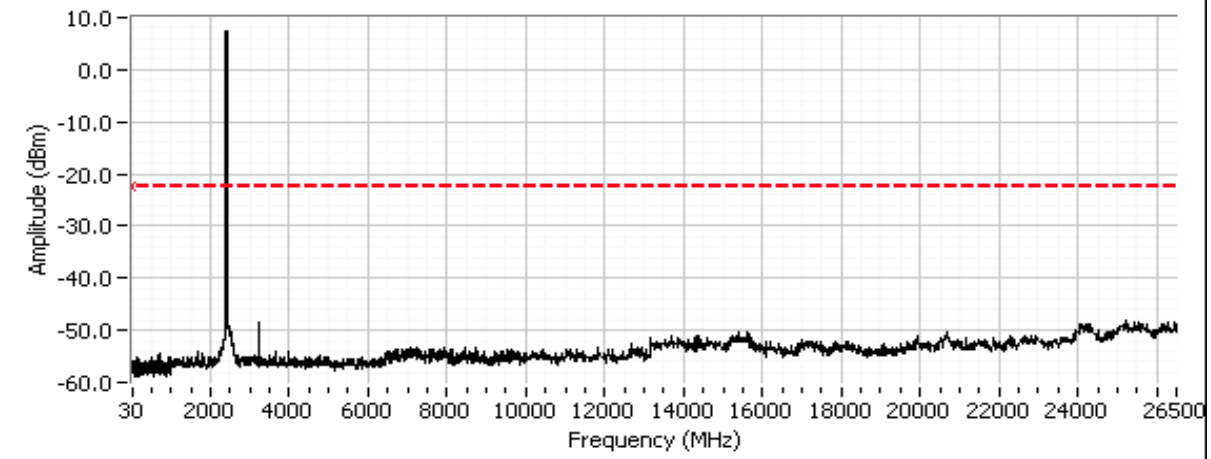

Out Of Band Spurious Emissions - 2412 MHz (802.11g MIMO)

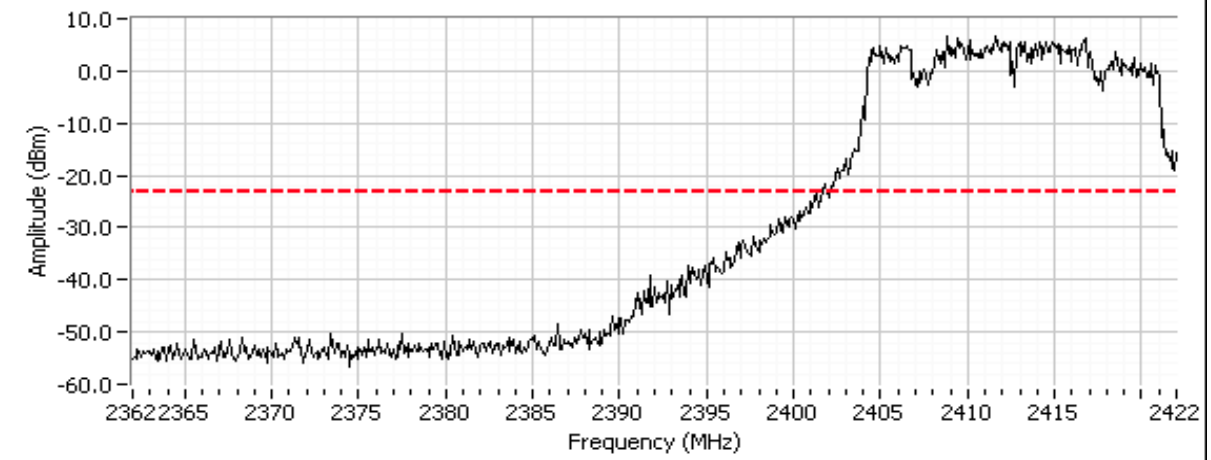

Client: Xirrus	Job Number: J71456
Model: XN-16 and XN-8	T-Log Number: T71643
	Account Manager: Susan Pezli
Contact: Steve Smith	
Standard: -	Class: N/A

Plots for center channel - 802.11g - , power setting(s) = 20.0

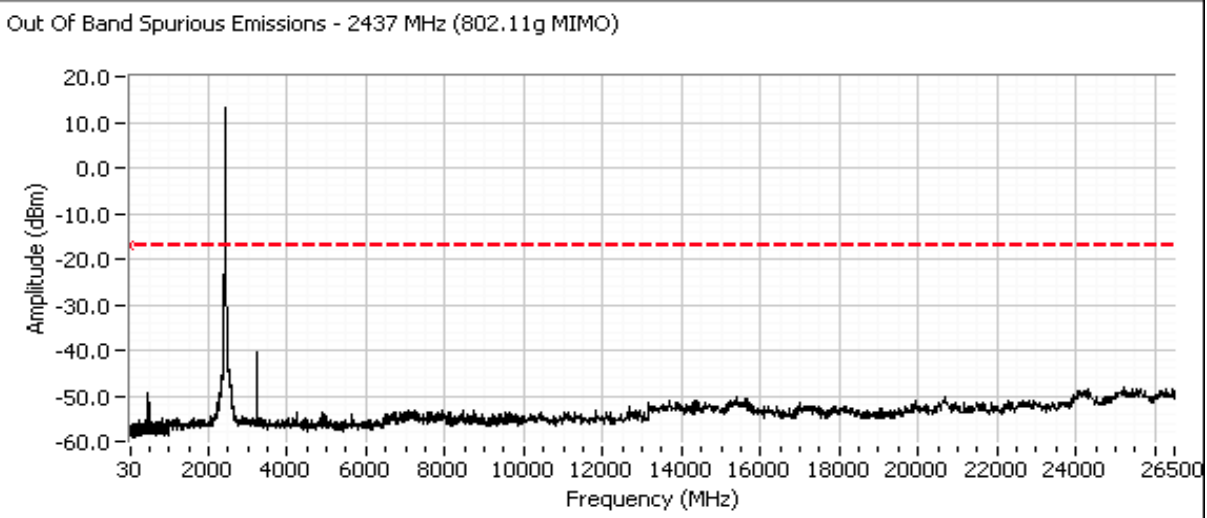

Plots for high channel - 802.11g - , power setting(s) = 13.5

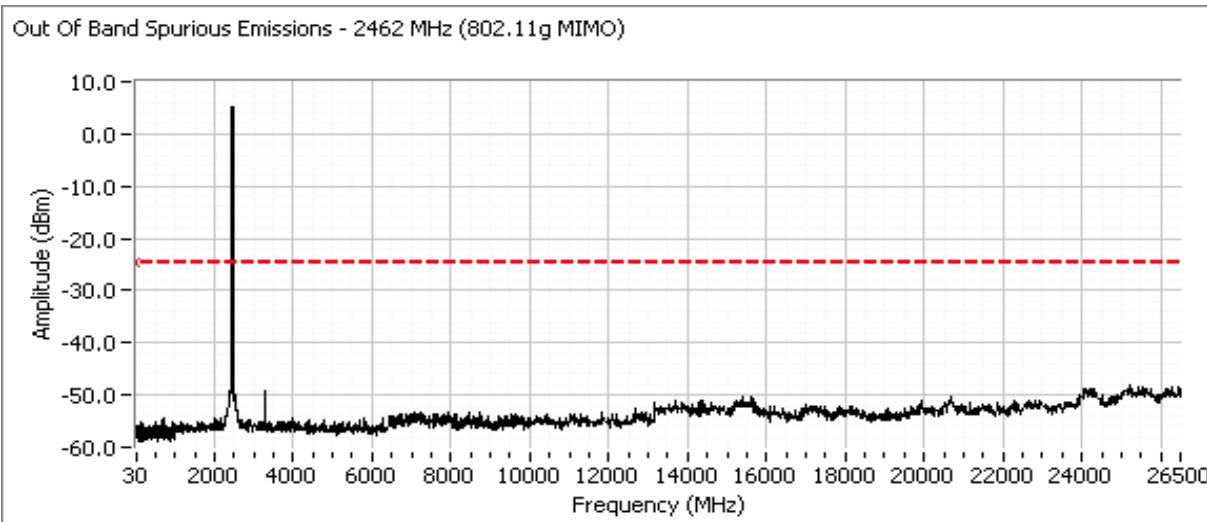

Client: Xirrus	Job Number: J71456
Model: XN-16 and XN-8	T-Log Number: T71643
	Account Manager: Susan Pezli
Contact: Steve Smith	
Standard: -	Class: N/A

RSS 210 and FCC 15.247 (DTS) Antenna Port Measurements
MIMO and Smart Antenna Systems
Power, PSD, Bandwidth and Spurious Emissions

Test Specific Details

Objective: The objective of this test session is to perform final qualification testing of the EUT with respect to the specification listed above.

Date of Test: 6/4/2008	Config. Used: -
Test Engineer: Mehran Birgani	Config Change: -
Test Location: Chamber #2	EUT Voltage: POE

General Test Configuration

The EUT was connected to the spectrum analyzer or power meter via a suitable attenuator.

All measurements have been corrected to allow for the external attenuators used.

Ambient Conditions: Temperature: 19 °C
 Rel. Humidity: 31 %

Summary of Results

Run #	Test Performed	Limit	Pass / Fail	Result / Margin
1	Output Power Chain A+B+C	15.247(b)	Pass	802.11n20: 23.0 dBm 802.11n40: 22.6 dBm
2	PSD Chain A+B+C	15.247(d)	Pass	n20: 7.4 dBm/3kHz n40: 6.4 dBm/3kHz
3	Minimum 6dB Bandwidth	15.247(a)	Pass	802.11n20: 17.8 MHz 802.11n40: 35.5 MHz
3	99% Bandwidth	RSS GEN	Pass	802.11n20: 18.3 MHz 802.11n40: 37.1 MHz
4	Spurious emissions	15.247(b)	Pass	All signals were more than 30dB below the fundamental

Modifications Made During Testing

No modifications were made to the EUT during testing

Deviations From The Standard

No deviations were made from the requirements of the standard.

Client: Xirrus	Job Number: J71456
Model: XN-16 and XN-8	T-Log Number: T71643
Contact: Steve Smith	Account Manager: Susan Pezli
Standard: -	Class: N/A

Run #1: Output Power - Chain A + B + C

Transmitted signal on chain is coherent ? No

Single radio Operating in the Band

2412 MHz - 802.11n20	Chain 1	Chain 2	Chain 3	Chain 4	Total Across All Chains		Limit	
Power Setting ^{Note 3}	13.0	13.0	13.0					
Output Power (dBm) ^{Note 1}	11.7	10.8	9.7		15.6 dBm	0.036 W	30.0 dBm	1.000 W
Antenna Gain (dBi) ^{Note 2}	3.0	3.0	3.0		3.0 dBi		Pass	
eirp (dBm) ^{Note 2}	14.7	13.8	12.7		18.6 dBm	0.072 W		

2437 MHz - 802.11n20	Chain 1	Chain 2	Chain 3	Chain 4	Total Across All Chains		Limit	
Power Setting ^{Note 3}	20.0	20.0	20.0					
Output Power (dBm) ^{Note 1}	18.4	17.5	18.6		23.0 dBm	0.198 W	30.0 dBm	1.000 W
Antenna Gain (dBi) ^{Note 2}	3.0	3.0	3.0		3.0 dBi		Pass	
eirp (dBm) ^{Note 2}	21.4	20.5	21.6		26.0 dBm	0.395 W		

2462 MHz - 802.11n20	Chain 1	Chain 2	Chain 3	Chain 4	Total Across All Chains		Limit	
Power Setting ^{Note 3}	9.5	9.5	9.5					
Output Power (dBm) ^{Note 1}	8.2	6.8	8.1		12.5 dBm	0.018 W	30.0 dBm	1.000 W
Antenna Gain (dBi) ^{Note 2}	3.0	3.0	3.0		3.0 dBi		Pass	
eirp (dBm) ^{Note 2}	11.2	9.8	11.1		15.5 dBm	0.036 W		

2422 MHz - 802.11n40	Chain 1	Chain 2	Chain 3	Chain 4	Total Across All Chains		Limit	
Power Setting ^{Note 3}	8.0	8.0	8.0					
Output Power (dBm) ^{Note 1}	7.2	6.0	6.2		11.3 dBm	0.013 W	30.0 dBm	1.000 W
Antenna Gain (dBi) ^{Note 2}	3.0	3.0	3.0		3.0 dBi		Pass	
eirp (dBm) ^{Note 2}	10.2	9.0	9.2		14.3 dBm	0.027 W		

2437 MHz - 802.11n40	Chain 1	Chain 2	Chain 3	Chain 4	Total Across All Chains		Limit	
Power Setting ^{Note 3}	20.0	20.0	20.0					
Output Power (dBm) ^{Note 1}	18.4	17.2	17.7		22.6 dBm	0.181 W	30.0 dBm	1.000 W
Antenna Gain (dBi) ^{Note 2}	3.0	3.0	3.0		3.0 dBi		Pass	
eirp (dBm) ^{Note 2}	21.4	20.2	20.7		25.6 dBm	0.360 W		

2452 MHz - 802.11n40	Chain 1	Chain 2	Chain 3	Chain 4	Total Across All Chains		Limit	
Power Setting ^{Note 3}	9.0	9.0	9.0					
Output Power (dBm) ^{Note 1}	7.7	6.7	7.7		12.2 dBm	0.016 W	30.0 dBm	1.000 W
Antenna Gain (dBi) ^{Note 2}	3.0	3.0	3.0		3.0 dBi		Pass	
eirp (dBm) ^{Note 2}	10.7	9.7	10.7		15.2 dBm	0.033 W		

Client: Xirrus	Job Number: J71456
Model: XN-16 and XN-8	T-Log Number: T71643
Contact: Steve Smith	Account Manager: Susan Pezli
Standard: -	Class: N/A

Three radios on non-overlapping channels, note 3

802.11n20	Chain 1	Chain 2	Chain 3	Chain 4	Total Across All Chains		Limit	
Power Setting ^{Note 3}	20.0	20.0	20.0					
Output Power (dBm) ^{Note 1}	18.4	17.5	18.6		27.7 dBm	0.594 W	30.0 dBm	1.000 W
Antenna Gain (dBi) ^{Note 2}	3.0	3.0	3.0			-1.8 dBi	Pass	
eirp (dBm) ^{Note 2}	21.4	20.5	21.6		26.0 dBm	0.395 W		

- Note 1:** Output power measured using a spectrum analyzer (see plots below) with RBW=1MHz, VB=3 MHz, sample detector, power averaging on (transmitted signal was continuous) and power integration over 50 MHz for 802.11n 20MHz and 80 MHz for 802.11n 40 MHz (reference method 1 of FCC DA 02-2138 for U-NII devices, August 30, 2002). Spurious limit becomes -30dBc.
- Note 2:** As there is no coherency between chains the total EIRP is the sum of the individual EIRPs and effective antenna gain equals the eirp divide by the sum of the power on each chain.
- Note 3:** The device has multiple radios, but the software limits operation in any band to ensure only non-overlapping channels are used (no two radios can operate on the same channel or on overlapping channels). In the 2412 - 2462 MHz band there can be a maximum of 3 radios active with all 3 using 20MHz channels (in 40MHz mode there can be only one 40MHz and one 20MHz channel used). The calculated total power (obtained by multiplying the output power on a single radio by the number of radios that can be operating in the band) demonstrates that the total output power still complies with the limit. The total power with one radio operating on a 20MHz channel and one on a 40MHz channel is lower than the power with three radios operating on 20MHz channels and is, therefore, not calculated.

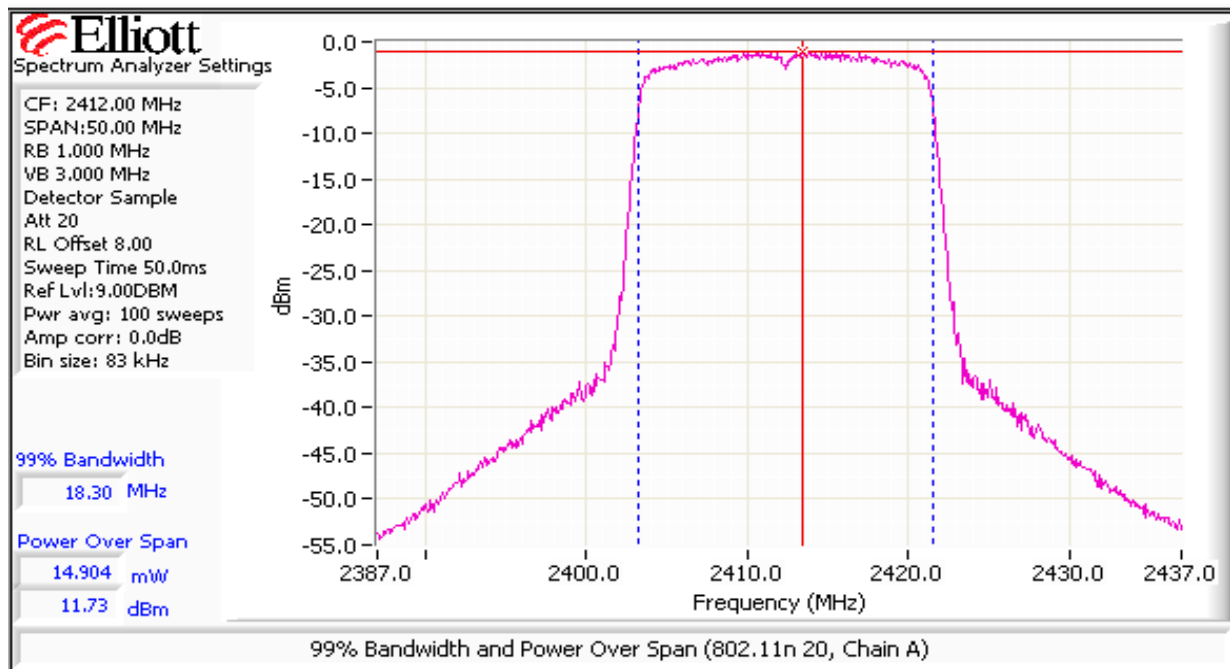

Client: Xirus	Job Number: J71456
Model: XN-16 and XN-8	T-Log Number: T71643
Contact: Steve Smith	Account Manager: Susan Pezli
Standard: -	Class: N/A

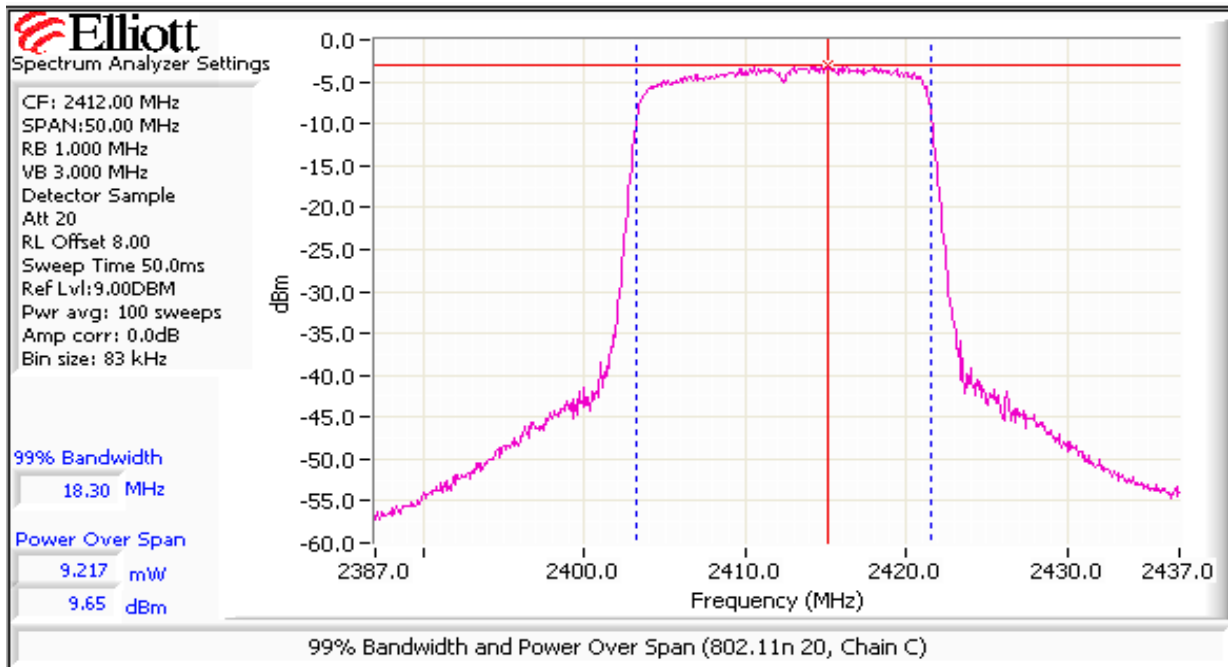
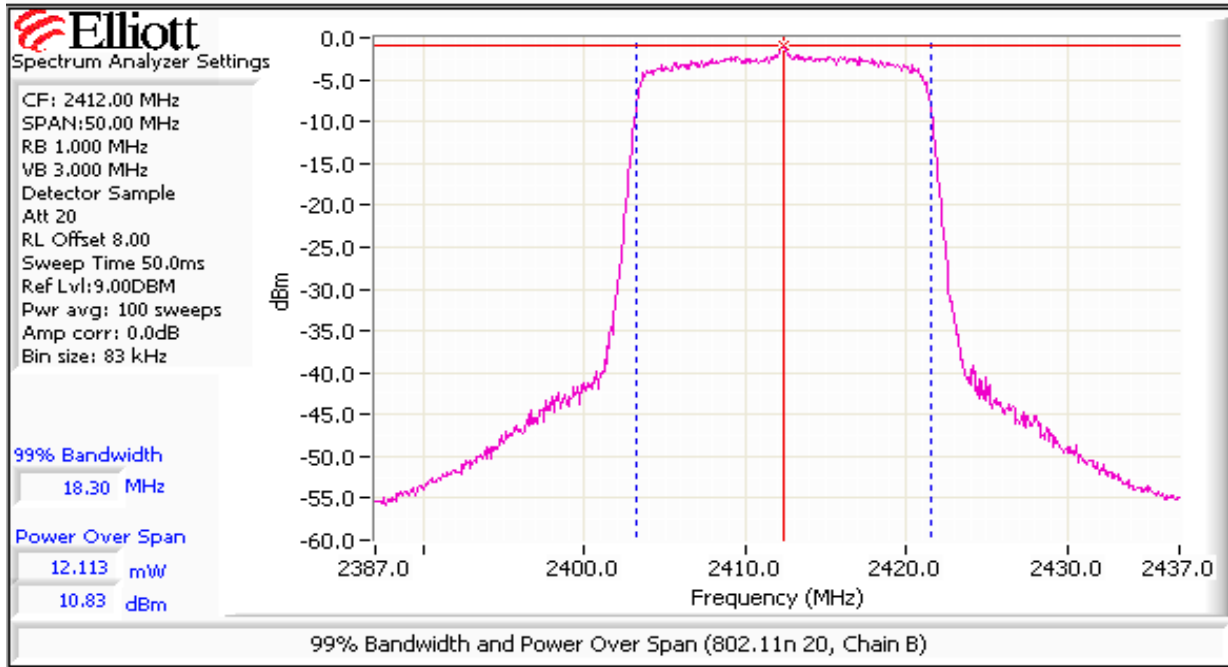

Client: Xirrus	Job Number: J71456
Model: XN-16 and XN-8	T-Log Number: T71643
Contact: Steve Smith	Account Manager: Susan Pezli
Standard: -	Class: N/A

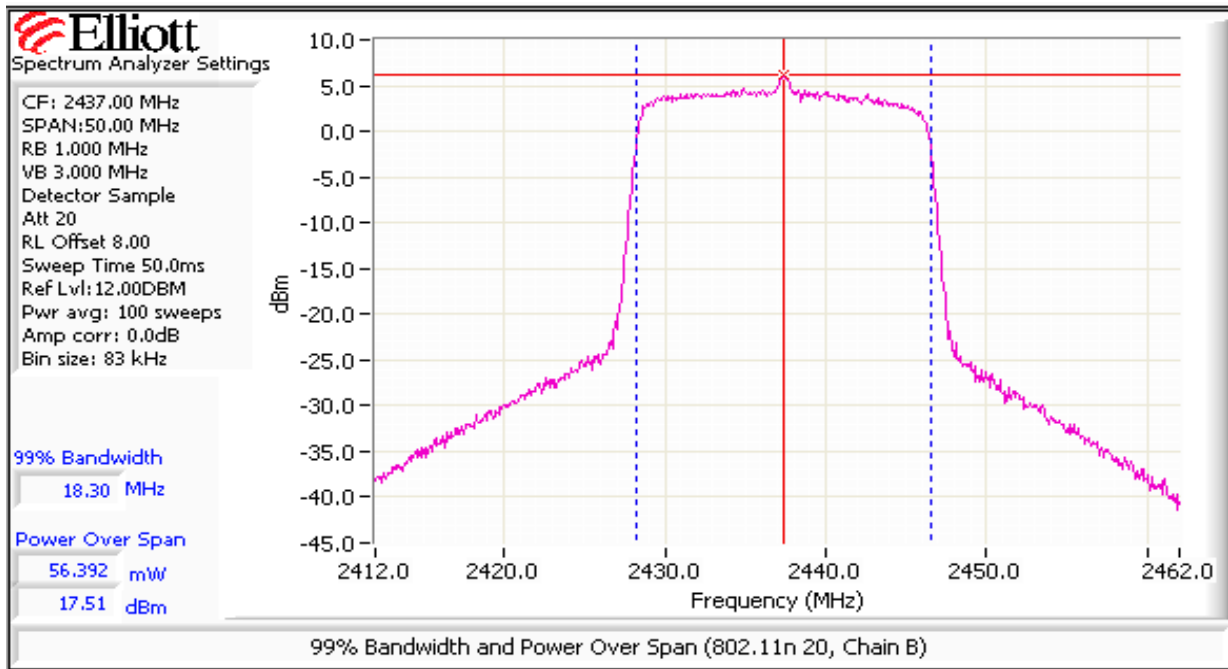
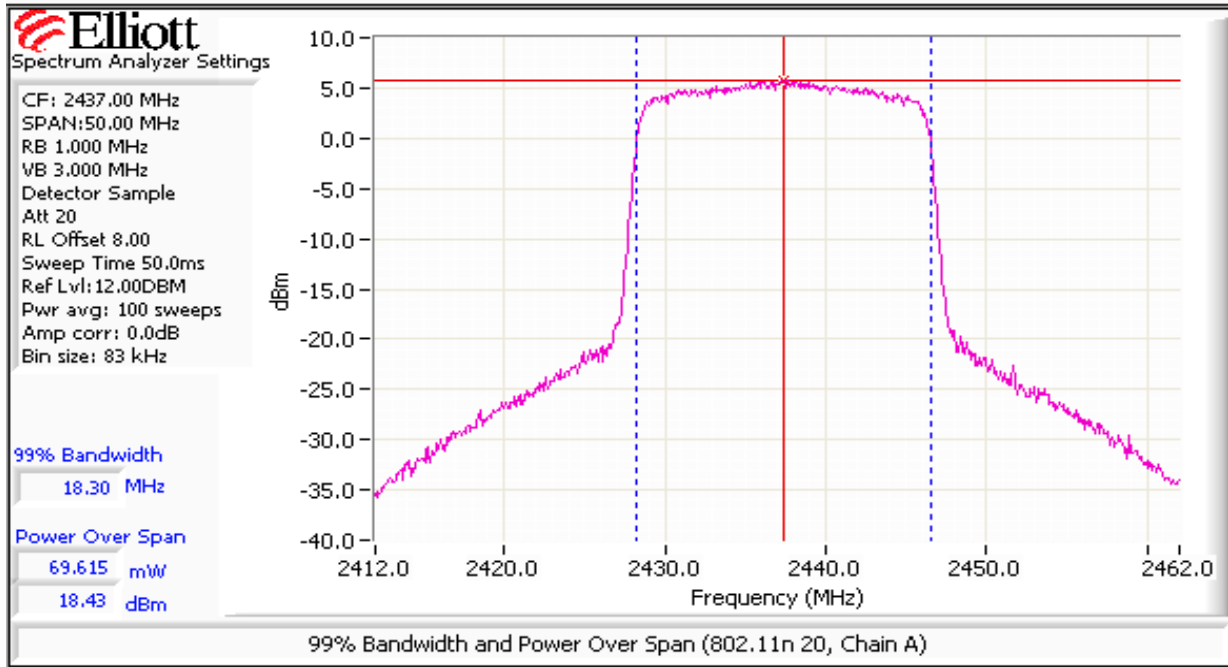

Client: Xirus	Job Number: J71456
Model: XN-16 and XN-8	T-Log Number: T71643
	Account Manager: Susan Pezli
Contact: Steve Smith	
Standard: -	Class: N/A

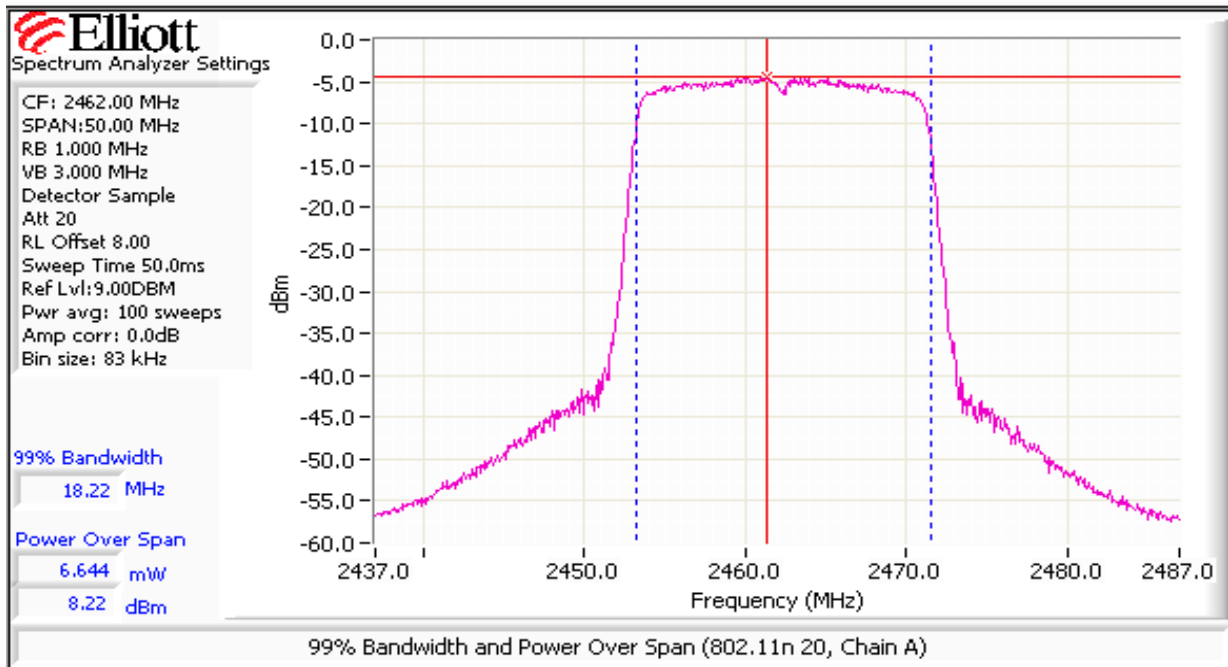
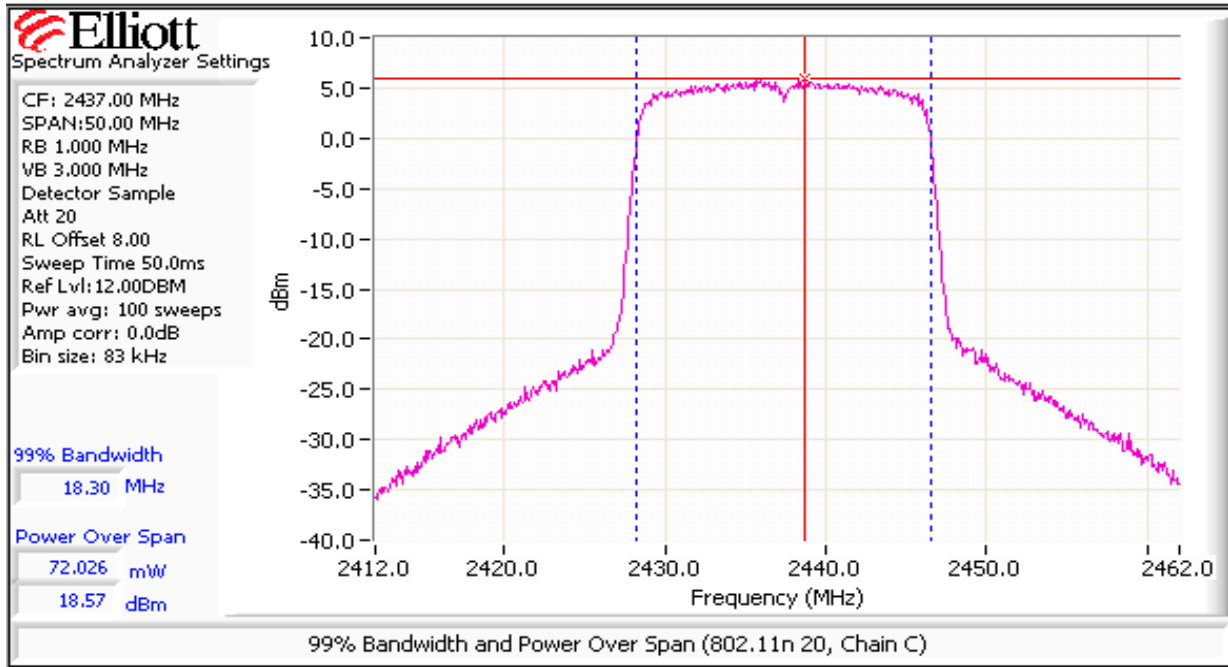

Client: Xirrus	Job Number: J71456
Model: XN-16 and XN-8	T-Log Number: T71643
	Account Manager: Susan Pezli
Contact: Steve Smith	
Standard: -	Class: N/A

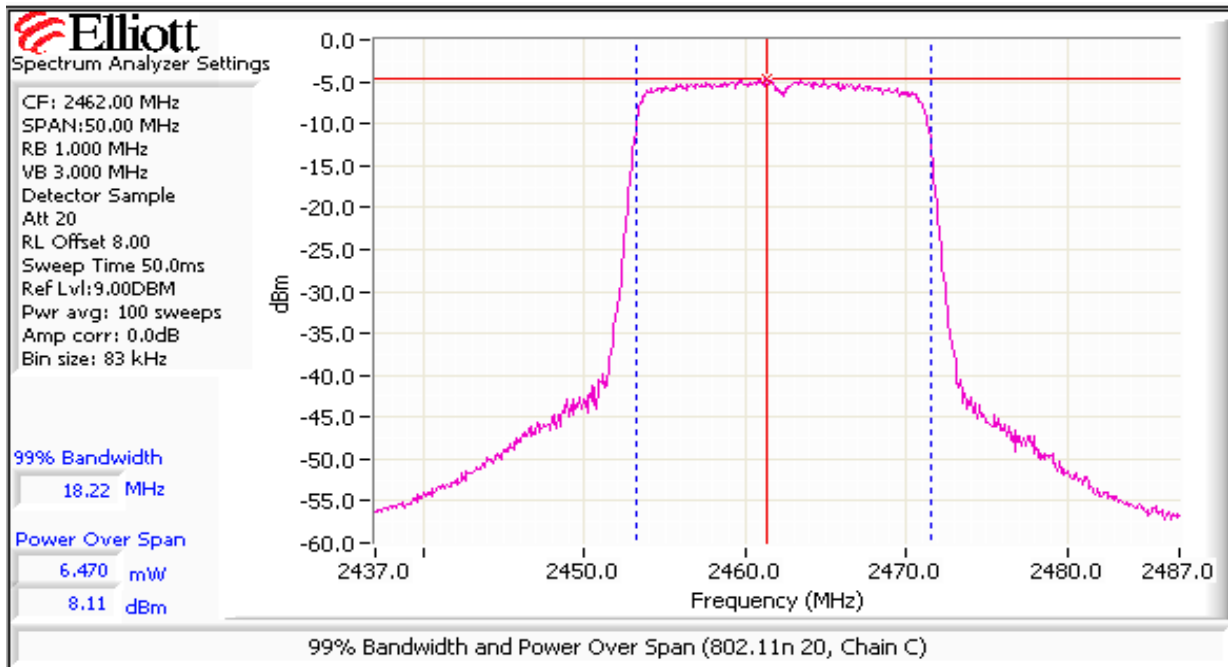
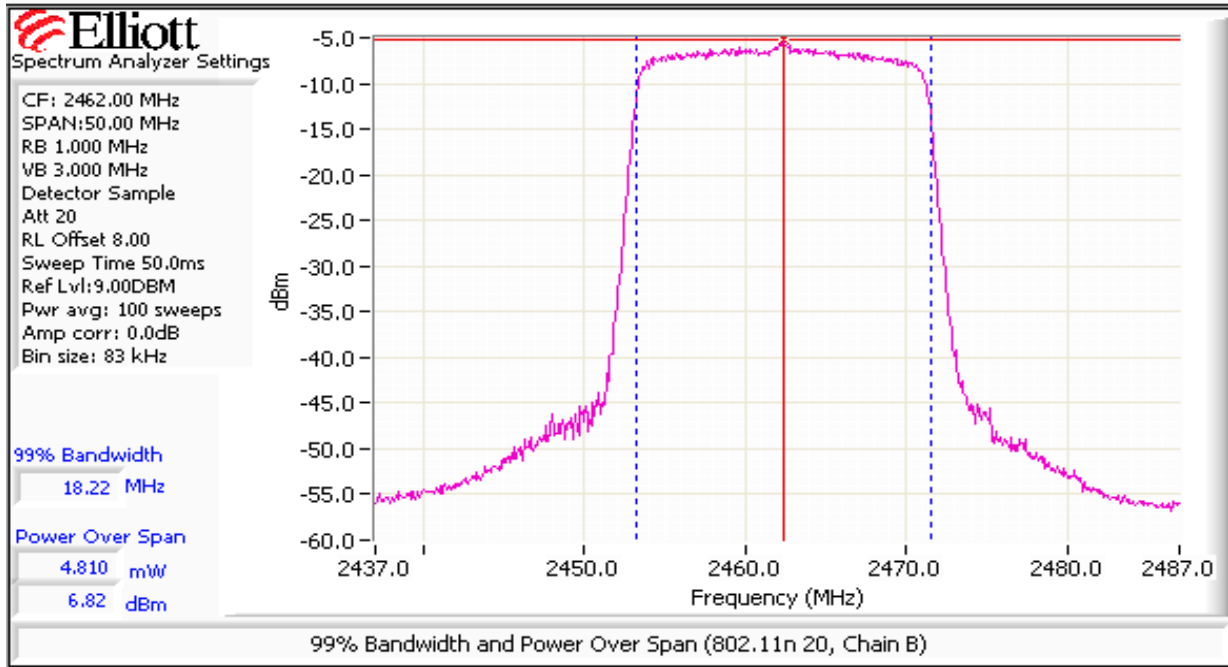

Client: Xirrus	Job Number: J71456
Model: XN-16 and XN-8	T-Log Number: T71643
Contact: Steve Smith	Account Manager: Susan Pezli
Standard: -	Class: N/A

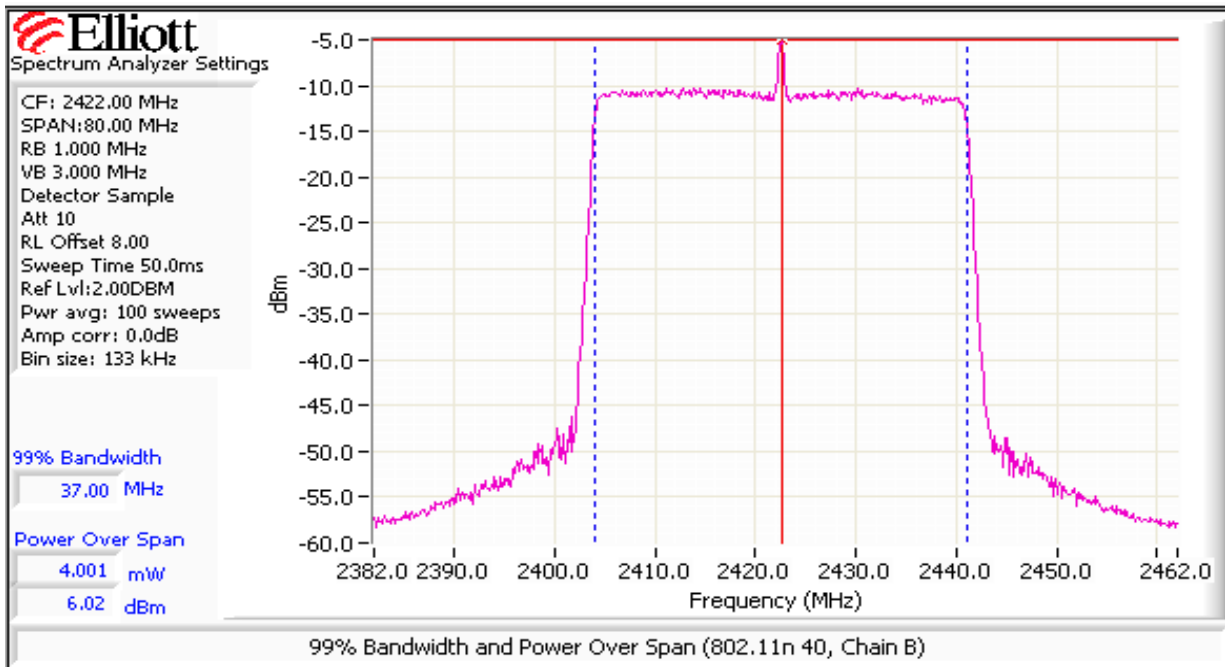
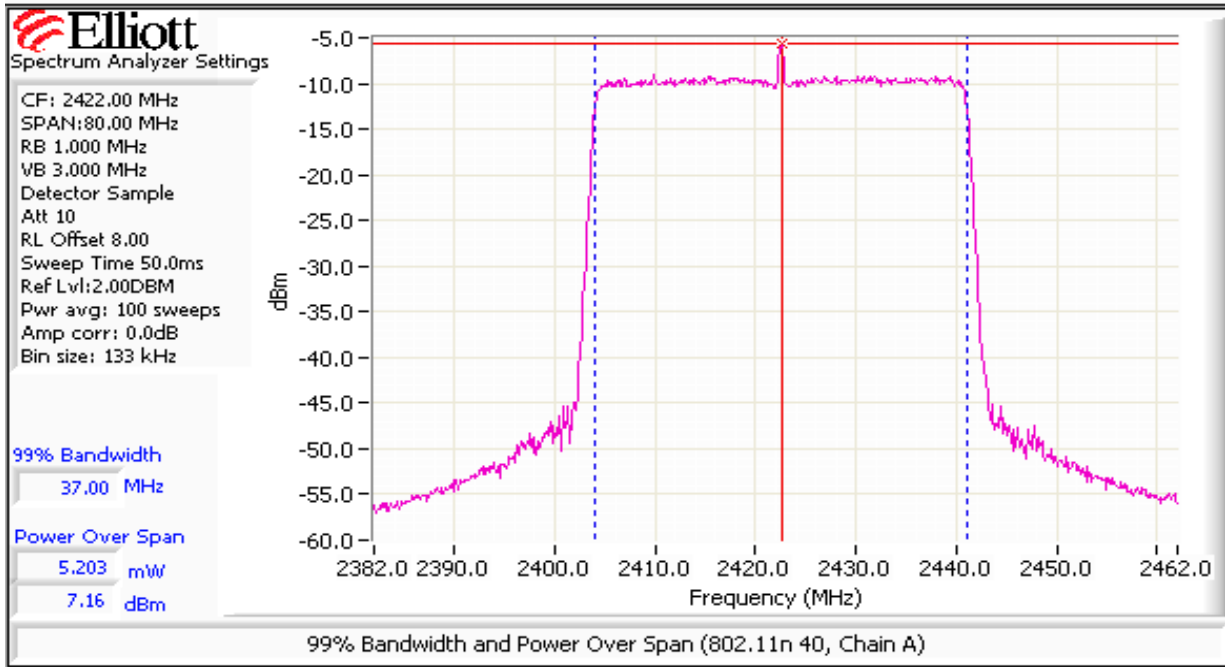

Client: Xirrus	Job Number: J71456
Model: XN-16 and XN-8	T-Log Number: T71643
	Account Manager: Susan Pezli
Contact: Steve Smith	
Standard: -	Class: N/A

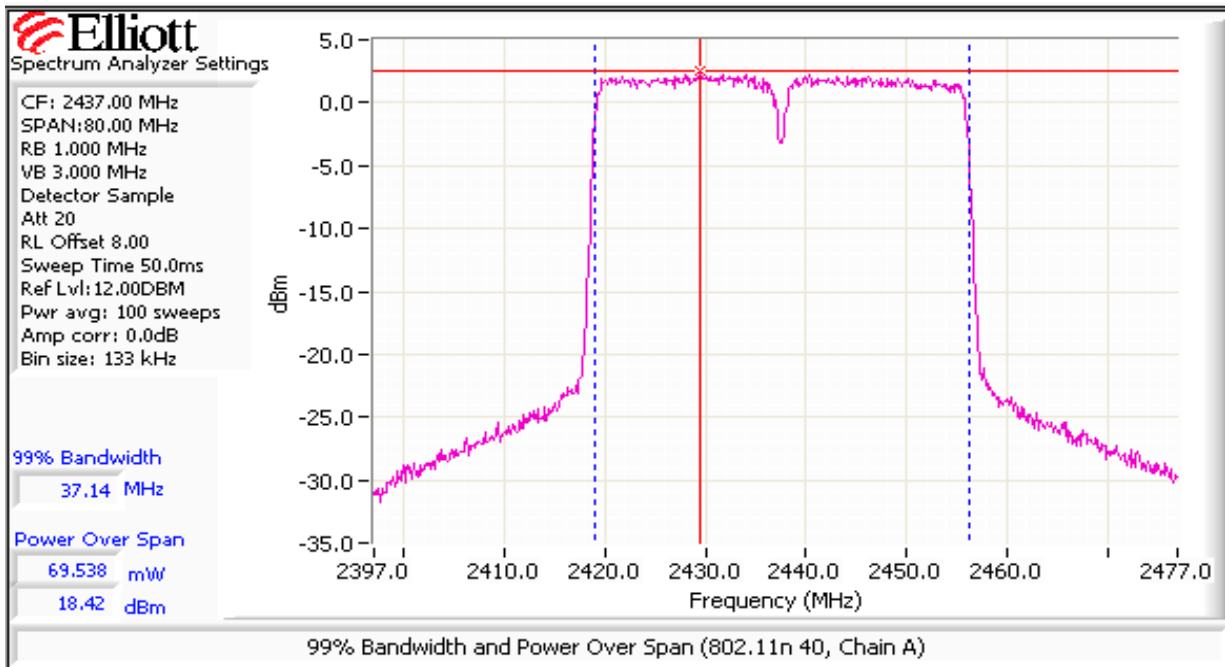
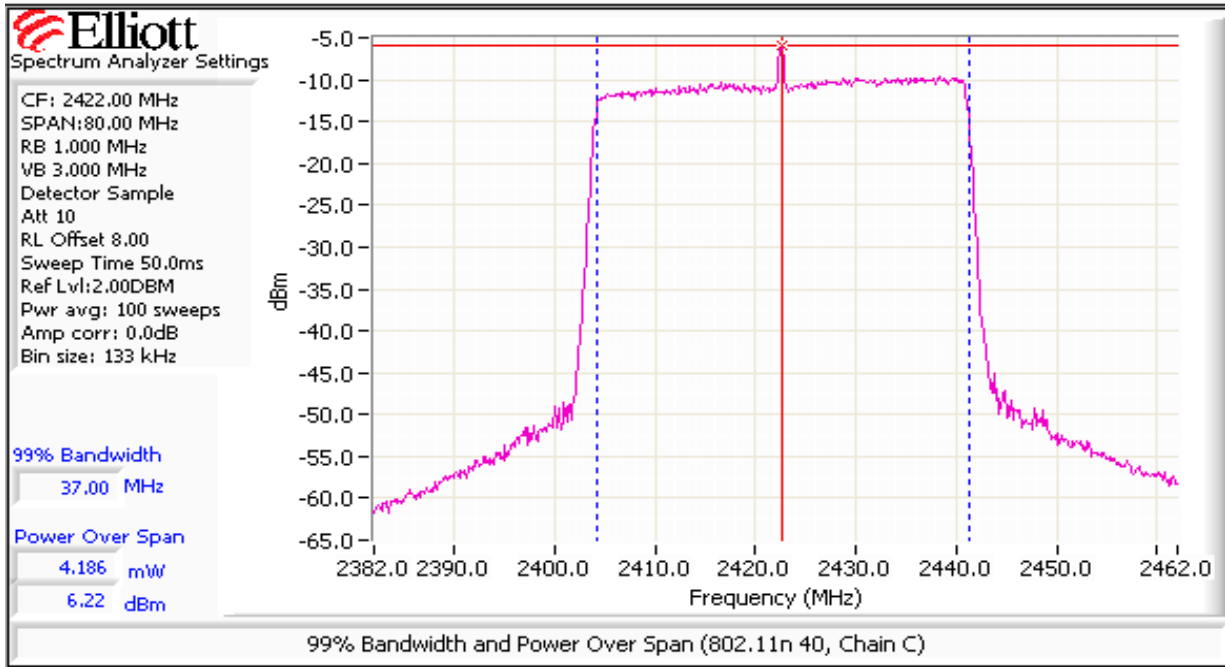

Client: Xirrus	Job Number: J71456
Model: XN-16 and XN-8	T-Log Number: T71643
Contact: Steve Smith	Account Manager: Susan Pezli
Standard: -	Class: N/A

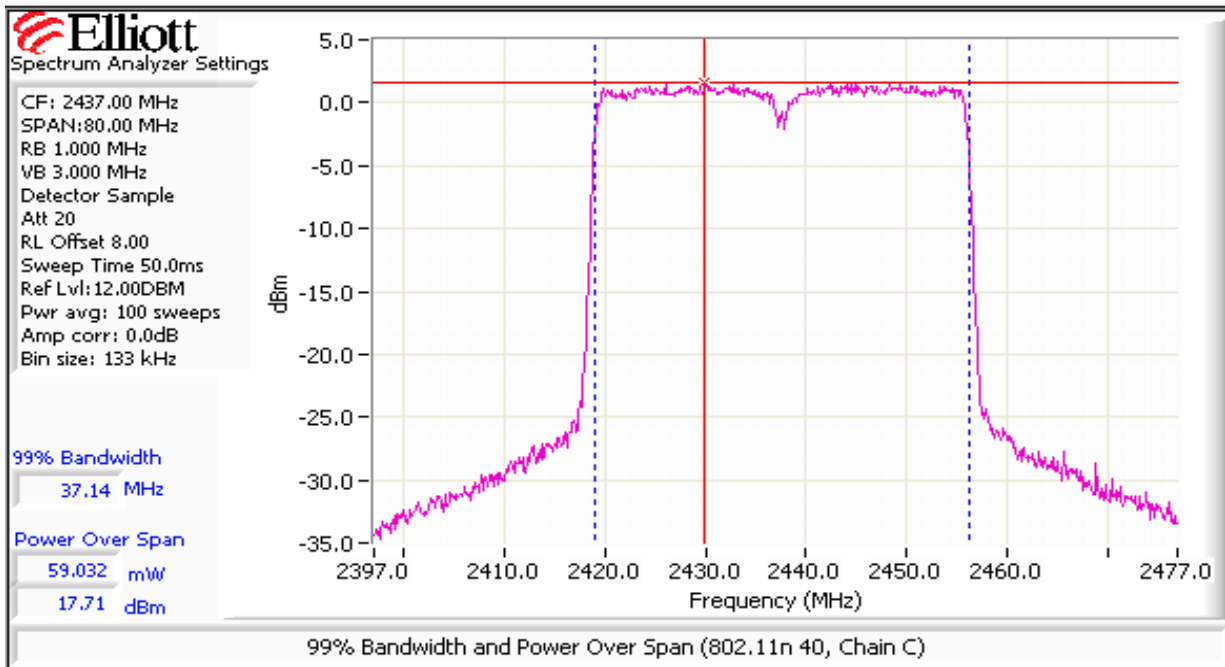
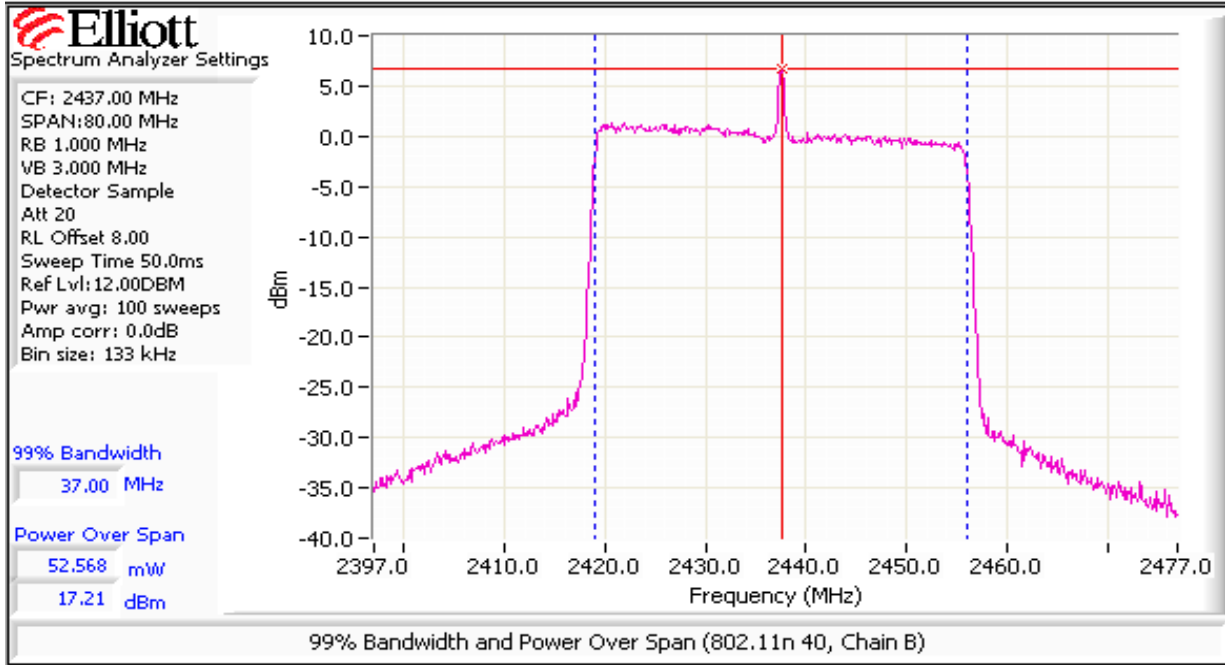

Client: Xirrus	Job Number: J71456
Model: XN-16 and XN-8	T-Log Number: T71643
Contact: Steve Smith	Account Manager: Susan Pezli
Standard: -	Class: N/A

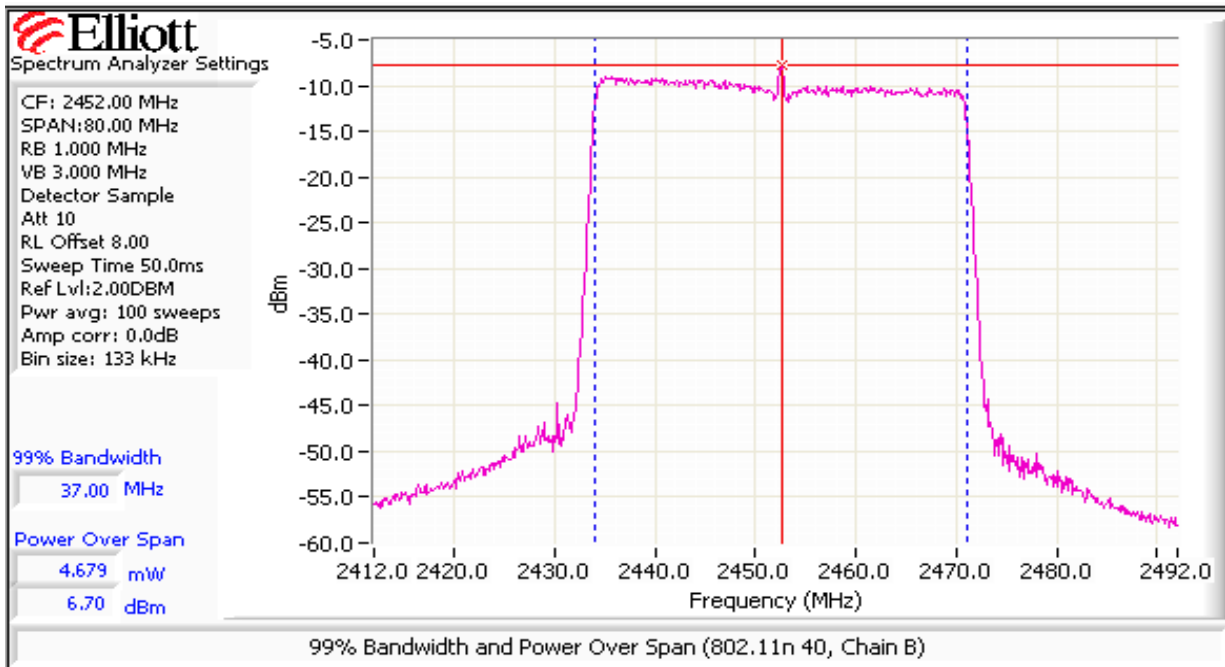
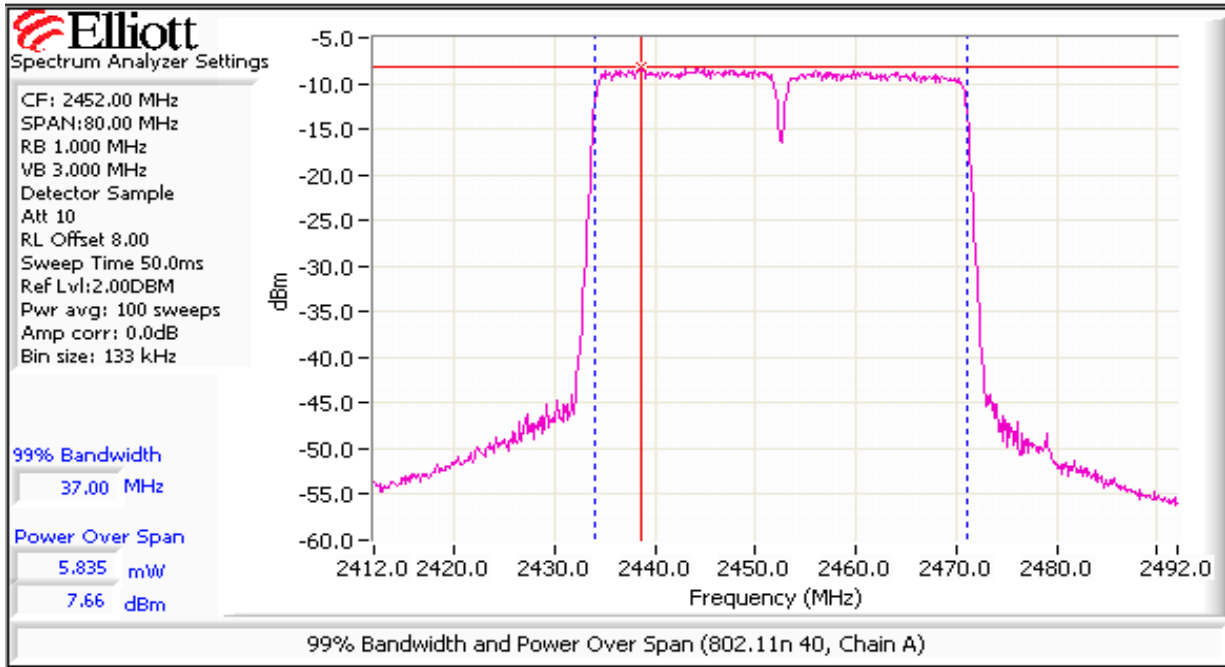

Client: Xirrus	Job Number: J71456
Model: XN-16 and XN-8	T-Log Number: T71643
Contact: Steve Smith	Account Manager: Susan Pezli
Standard: -	Class: N/A

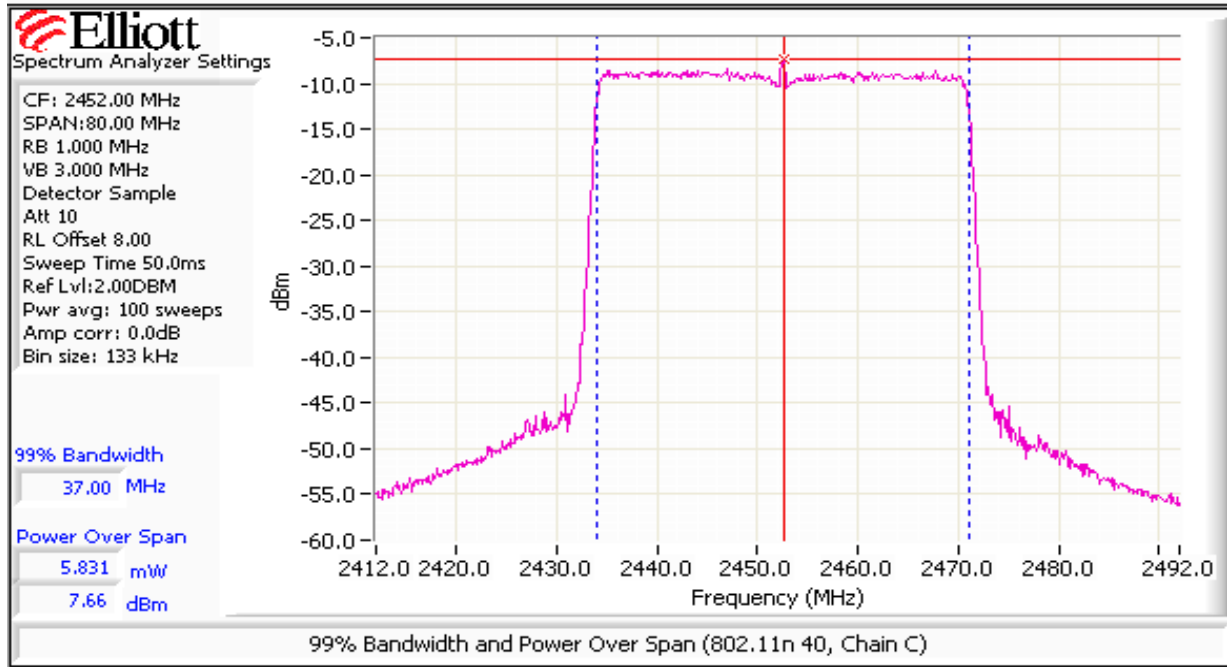

Run #2: Power spectral Density

Power Setting	Frequency (MHz)	PSD (dBm/3kHz) ^{Note 1}				Total	Limit dBm/3kHz	Result
		Chain 1	Chain 2	Chain 3	Chain 4			
13.0	2412 802.11n20	-11.6	-2.7	-5.0	-0.4	8.0	Pass	
20.0	2437 802.11n20	4.5	2.8	-1.4	7.4	8.0	Pass	
9.5	2462 802.11n20	-11.1	-6.6	-14.8	-4.8	8.0	Pass	
8.0	2422 802.11n40	-17.6	-9.2	-10.5	-6.4	8.0	Pass	
20.0	2437 802.11n40	-3.6	5.1	-1.4	6.4	8.0	Pass	
9.0	2452 802.11n40	-17.2	-7.6	-7.1	-4.1	8.0	Pass	

Note 1:	Power spectral density measured using RB=3 kHz, VB=10kHz, analyzer with peak detector and with a sweep time set to ensure a dwell time of at least 1 second per 3kHz. The measurement is made at the frequency of PPSD determined from preliminary scans using RB=3kHz using multiple sweeps at a faster rate over the 6dB bandwidth of the signal.
Note 2:	The operation of multiple radios in the band does not affect power spectral density as radios cannot operate on overlapping channels.

Client: Xirus	Job Number: J71456
Model: XN-16 and XN-8	T-Log Number: T71643
Contact: Steve Smith	Account Manager: Susan Pezli
Standard: -	Class: N/A

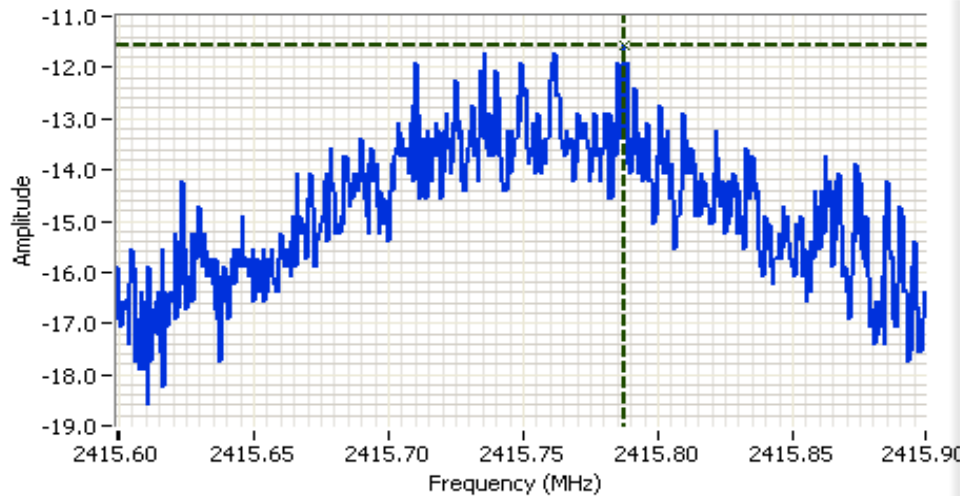

Analyzer Settings

HP8564E,006,EMI,UK6
 CF: 2415.749 MHz
 SPAN:300 kHz
 RB 3.00 kHz
 VB 10.00 kHz
 Detector POS
 Att 10
 RL Offset 8.00
 Sweep Time 100.0s
 Ref Lvl:-8.40DBM

Comments

PSD: -11.6 dBm/3kHz
 802.11n 20MHz
 Chain A

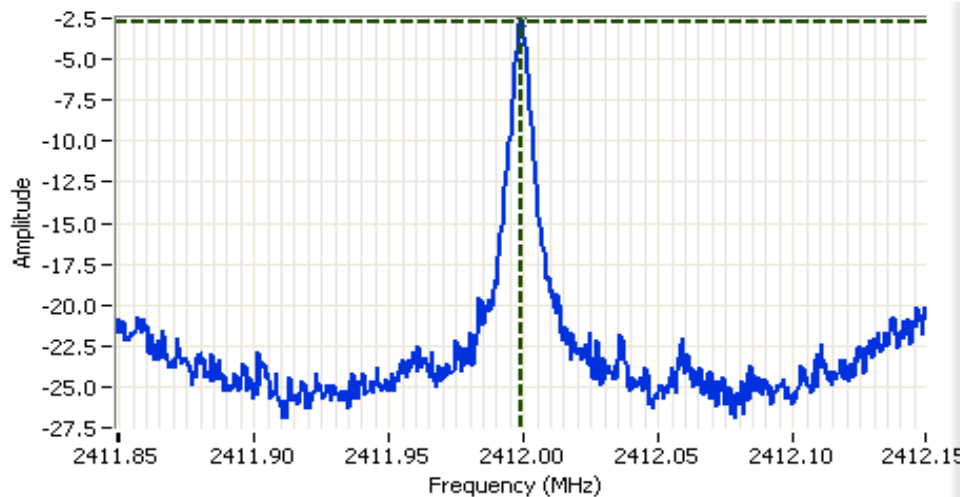
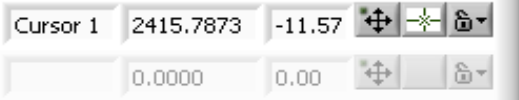

Analyzer Settings

HP8564E,006,EMI,UK6
 CF: 2411.999 MHz
 SPAN:300 kHz
 RB 3.00 kHz
 VB 10.00 kHz
 Detector POS
 Att 10
 RL Offset 8.00
 Sweep Time 100.0s
 Ref Lvl:-1.20DBM

Comments

PSD: -2.7 dBm/3kHz
 802.11n 20MHz
 Chain B

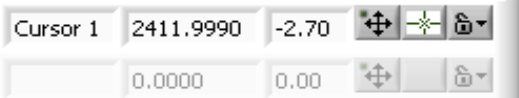

Client: Xirrus	Job Number: J71456
Model: XN-16 and XN-8	T-Log Number: T71643
Contact: Steve Smith	Account Manager: Susan Pezli
Standard: -	Class: N/A

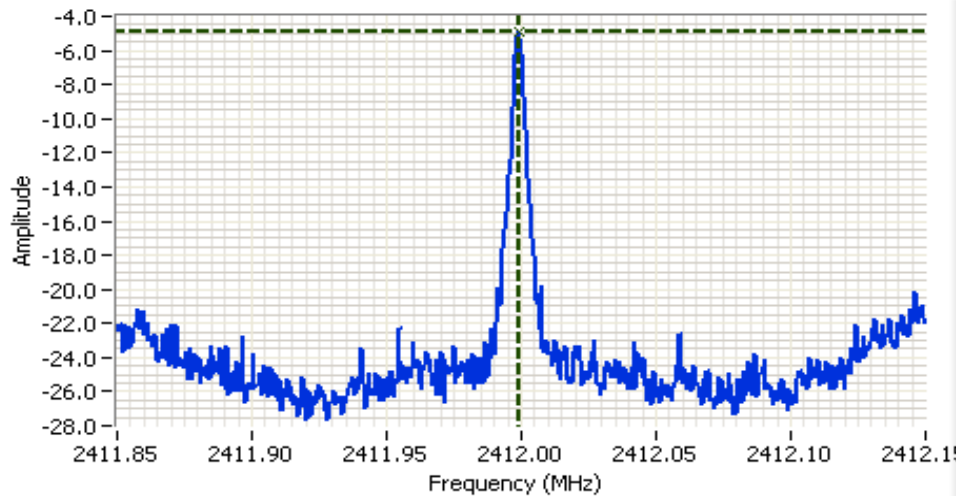

Analyzer Settings
 HP8564E,006,EMI,UK6
 CF: 2412.000 MHz
 SPAN:300 kHz
 RB 3.00 kHz
 VB 10.00 kHz
 Detector POS
 Att 10
 RL Offset 8.00
 Sweep Time 100.0s
 Ref Lvl:0.20DBM

Comments
 PSD: -5.0 dBm/3kHz
 802.11n 20MHz
 Chain C

Cursor 1 2411.9990 -4.97 [Icons]
 0.0000 0.00 [Icons]

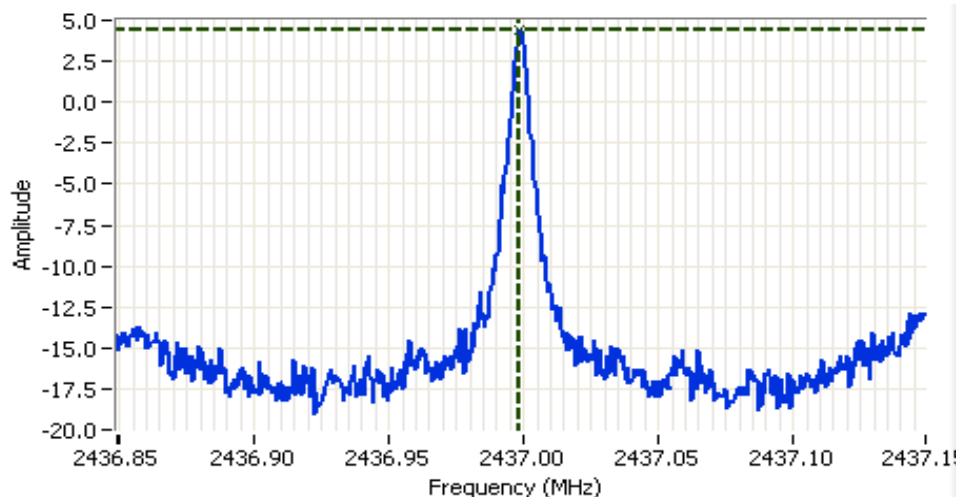

Analyzer Settings
 HP8564E,006,EMI,UK6
 CF: 2436.999 MHz
 SPAN:300 kHz
 RB 3.00 kHz
 VB 10.00 kHz
 Detector POS
 Att 10
 RL Offset 8.00
 Sweep Time 100.0s
 Ref Lvl:7.80DBM

Comments
 PSD: 4.5 dBm/3kHz
 802.11n 20MHz
 Chain A

Cursor 1 2436.9985 4.47 [Icons]
 0.0000 0.00 [Icons]



Client: Xirrus	Job Number: J71456
Model: XN-16 and XN-8	T-Log Number: T71643
Contact: Steve Smith	Account Manager: Susan Pezli
Standard: -	Class: N/A

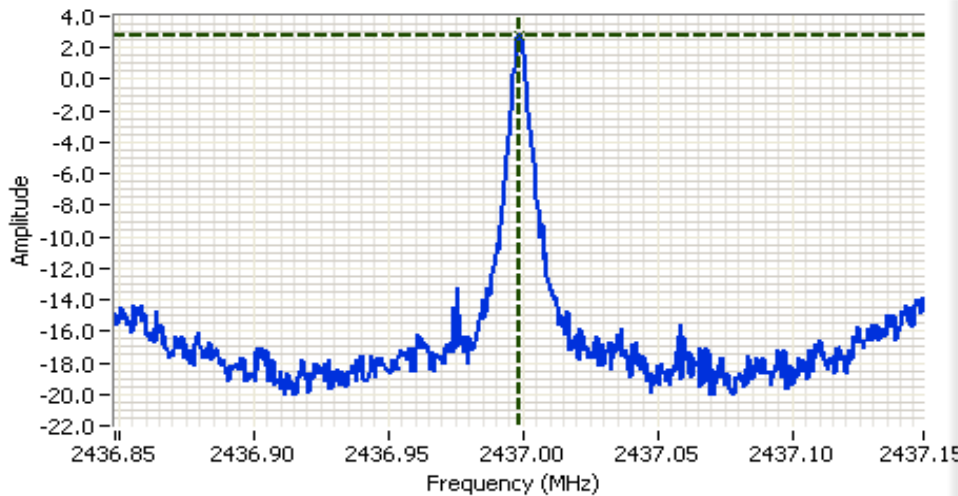

Analyzer Settings
 HP8564E,006,EMI,UK6
 CF: 2436.999 MHz
 SPAN:300 kHz
 RB 3.00 kHz
 VB 10.00 kHz
 Detector POS
 Att 10
 RL Offset 8.00
 Sweep Time 100.0s
 Ref Lvl:6.80DBM

Comments
 PSD: 2.8 dBm/3kHz
 802.11n 20MHz
 Chain B

Cursor 1 2436.9985 2.80 [Icons]
 0.0000 0.00 [Icons]

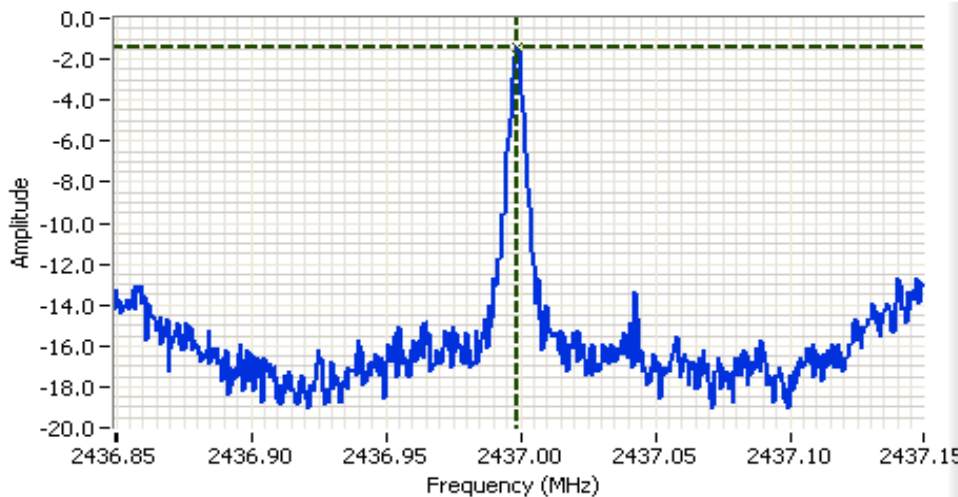

Analyzer Settings
 HP8564E,006,EMI,UK6
 CF: 2437.000 MHz
 SPAN:300 kHz
 RB 3.00 kHz
 VB 10.00 kHz
 Detector POS
 Att 10
 RL Offset 8.00
 Sweep Time 100.0s
 Ref Lvl:0.10DBM

Comments
 PSD: -1.4 dBm/3kHz
 802.11n 20MHz
 Chain C

Cursor 1 2436.9985 -1.40 [Icons]
 0.0000 0.00 [Icons]



Client: Xirus	Job Number: J71456
Model: XN-16 and XN-8	T-Log Number: T71643
Contact: Steve Smith	Account Manager: Susan Pezli
Standard: -	Class: N/A

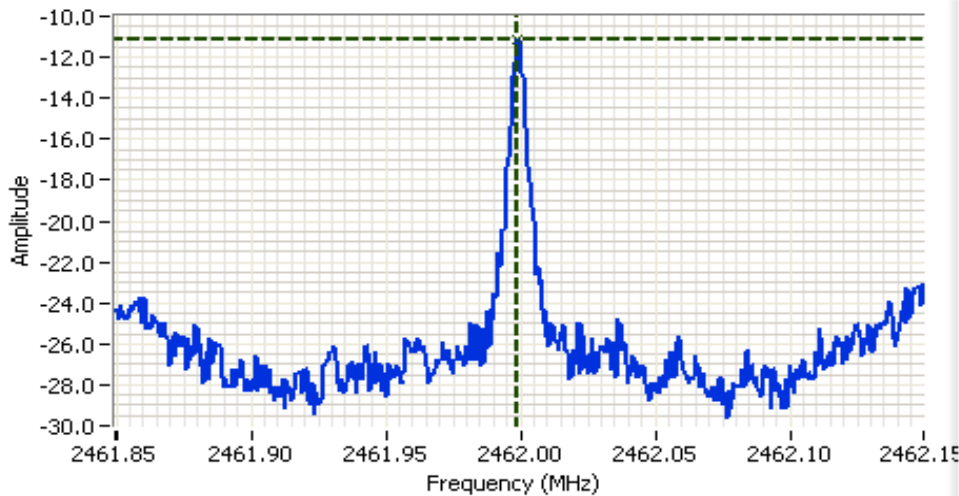

Analyzer Settings
 HP8564E,006,EMI,UK6
 CF: 2462.000 MHz
 SPAN:300 kHz
 RB 3.00 kHz
 VB 10.00 kHz
 Detector POS
 Att 10
 RL Offset 8.00
 Sweep Time 100.0s
 Ref Lvl:-7.10DBM

Comments
 PSD: -11.1 dBm/3kHz
 802.11n 20MHz
 Chain A

Cursor 1 2461.9990 -11.10

0.0000 0.00

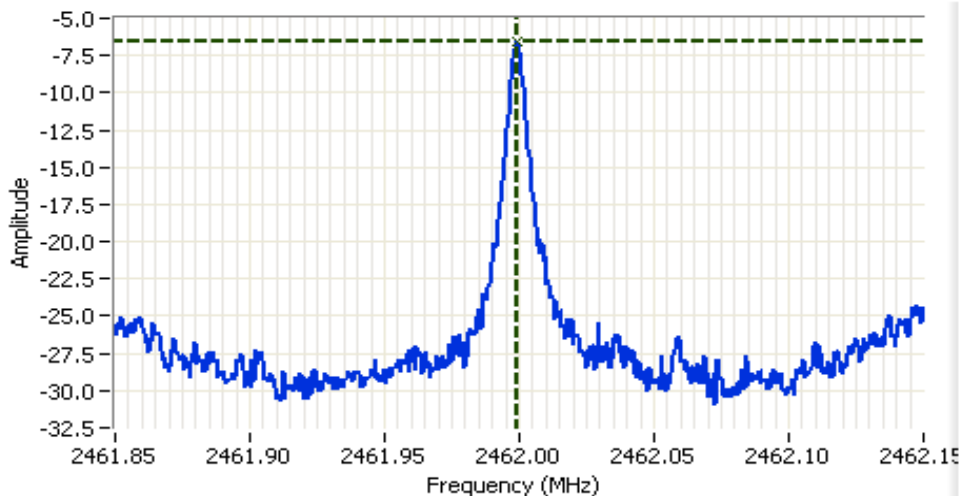

Analyzer Settings
 HP8564E,006,EMI,UK6
 CF: 2462.000 MHz
 SPAN:300 kHz
 RB 3.00 kHz
 VB 10.00 kHz
 Detector POS
 Att 10
 RL Offset 8.00
 Sweep Time 100.0s
 Ref Lvl:-5.40DBM

Comments
 PSD: -6.6 dBm/3kHz
 802.11n 20MHz
 Chain B

Cursor 1 2461.9990 -6.57

0.0000 0.00



Client: Xirus	Job Number: J71456
Model: XN-16 and XN-8	T-Log Number: T71643
Contact: Steve Smith	Account Manager: Susan Pezli
Standard: -	Class: N/A

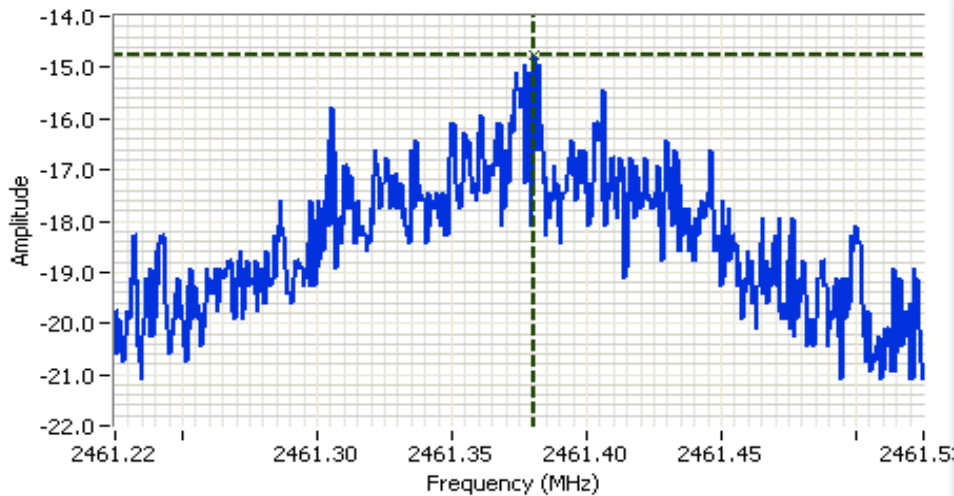

Analyzer Settings
 HP8564E,006,EMI,UK6
 CF: 2461.375 MHz
 SPAN:300 kHz
 RB 3.00 kHz
 VB 10.00 kHz
 Detector POS
 Att 10
 RL Offset 8.00
 Sweep Time 100.0s
 Ref Lvl:-10.10DBM

Comments
 PSD: -14.8 dBm/3kHz
 802.11n 20MHz
 Chain C

Cursor 1 2461.3805 -14.77

0.0000 0.00

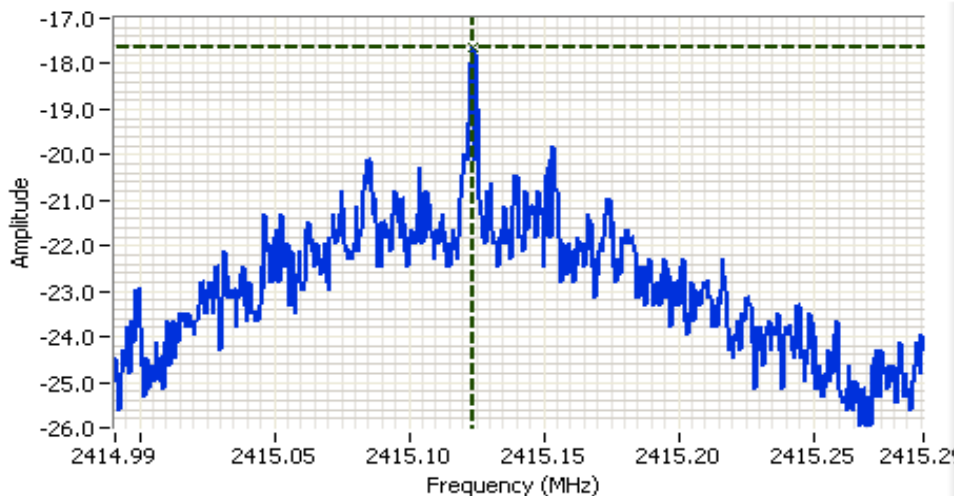

Analyzer Settings
 HP8564E,006,EMI,UK6
 CF: 2415.141 MHz
 SPAN:300 kHz
 RB 3.00 kHz
 VB 10.00 kHz
 Detector POS
 Att 10
 RL Offset 8.00
 Sweep Time 100.0s
 Ref Lvl:-15.30DBM

Comments
 PSD: -17.6 dBm/3kHz
 802.11n 40MHz
 Chain A

Cursor 1 2415.1239 -17.63

0.0000 0.00



Client: Xirrus	Job Number: J71456
Model: XN-16 and XN-8	T-Log Number: T71643
Contact: Steve Smith	Account Manager: Susan Pezli
Standard: -	Class: N/A

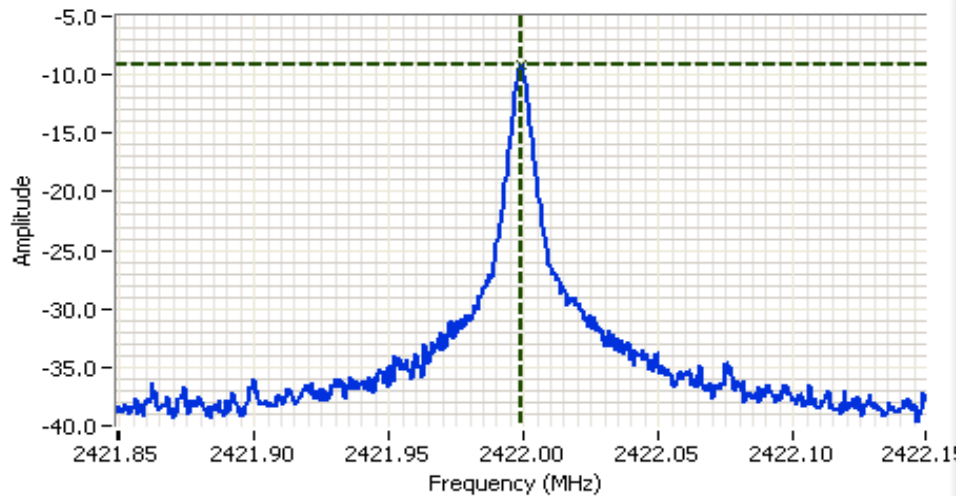

Analyzer Settings
 HP8564E,006,EMI,UK6
 CF: 2421.999 MHz
 SPAN:300 kHz
 RB 3.00 kHz
 VB 10.00 kHz
 Detector POS
 Att 10
 RL Offset 8.00
 Sweep Time 100.0s
 Ref Lvl:-5.20DBM

Comments
 PSD: -9.2 dBm/3kHz
 802.11n 40MHz
 Chain B

Cursor 1 2421.9990 -9.20 [Icons]
 0.0000 0.00 [Icons]

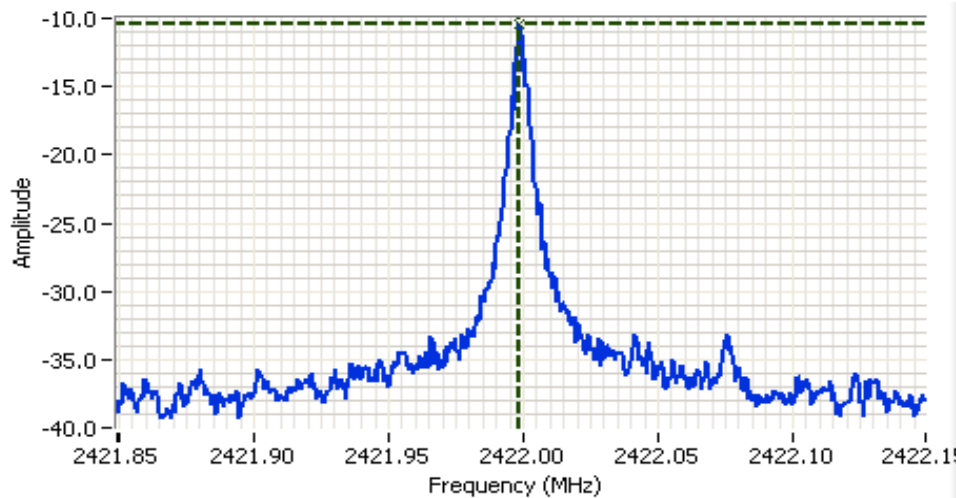

Analyzer Settings
 HP8564E,006,EMI,UK6
 CF: 2421.999 MHz
 SPAN:300 kHz
 RB 3.00 kHz
 VB 10.00 kHz
 Detector POS
 Att 10
 RL Offset 8.00
 Sweep Time 100.0s
 Ref Lvl:-9.80DBM

Comments
 PSD: -10.5 dBm/3kHz
 802.11n 40MHz
 Chain C

Cursor 1 2421.9983 -10.47 [Icons]
 0.0000 0.00 [Icons]



Client: Xirrus	Job Number: J71456
Model: XN-16 and XN-8	T-Log Number: T71643
Contact: Steve Smith	Account Manager: Susan Pezli
Standard: -	Class: N/A

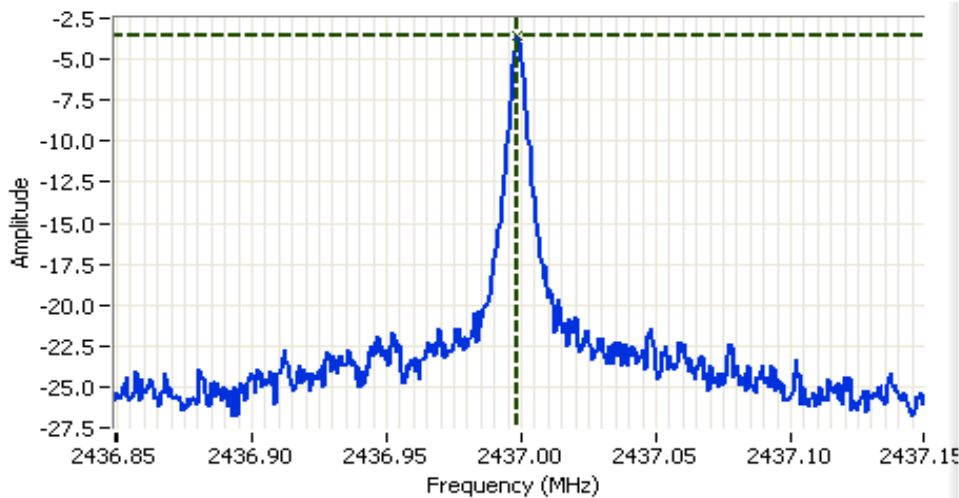

Analyzer Settings
 HP8564E,006,EMI,UK6
 CF: 2436.999 MHz
 SPAN:300 kHz
 RB 3.00 kHz
 VB 10.00 kHz
 Detector POS
 Att 10
 RL Offset 8.00
 Sweep Time 100.0s
 Ref Lvl:0.10DBM

Comments
 PSD: -3.6 dBm/3kHz
 802.11n 40MHz
 Chain A

Cursor 1 2436.9983 -3.57 [Icons]
 0.0000 0.00 [Icons]

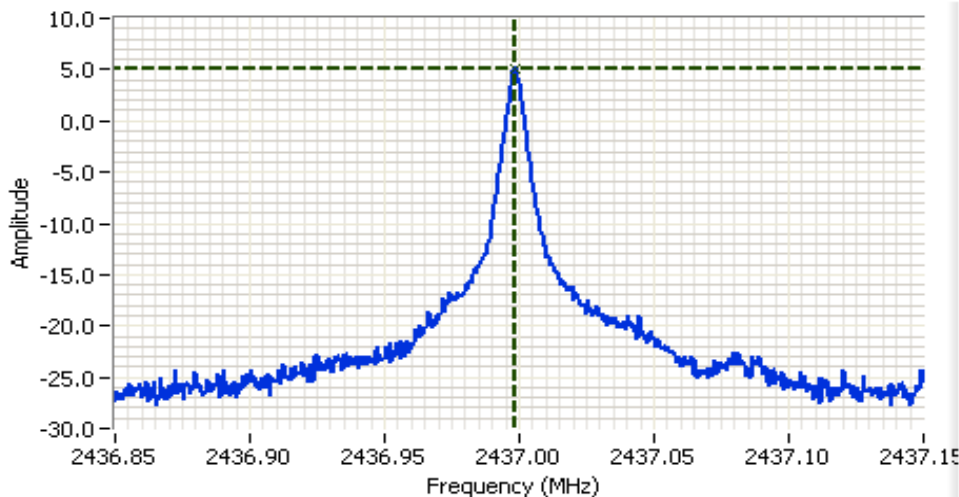

Analyzer Settings
 HP8564E,006,EMI,UK6
 CF: 2437.000 MHz
 SPAN:300 kHz
 RB 3.00 kHz
 VB 10.00 kHz
 Detector POS
 Att 10
 RL Offset 8.00
 Sweep Time 100.0s
 Ref Lvl:7.60DBM

Comments
 PSD: 5.1 dBm/3kHz
 802.11n 40MHz
 Chain B

Cursor 1 2436.9985 5.10 [Icons]
 0.0000 0.00 [Icons]



Client: Xirrus	Job Number: J71456
Model: XN-16 and XN-8	T-Log Number: T71643
Contact: Steve Smith	Account Manager: Susan Pezli
Standard: -	Class: N/A

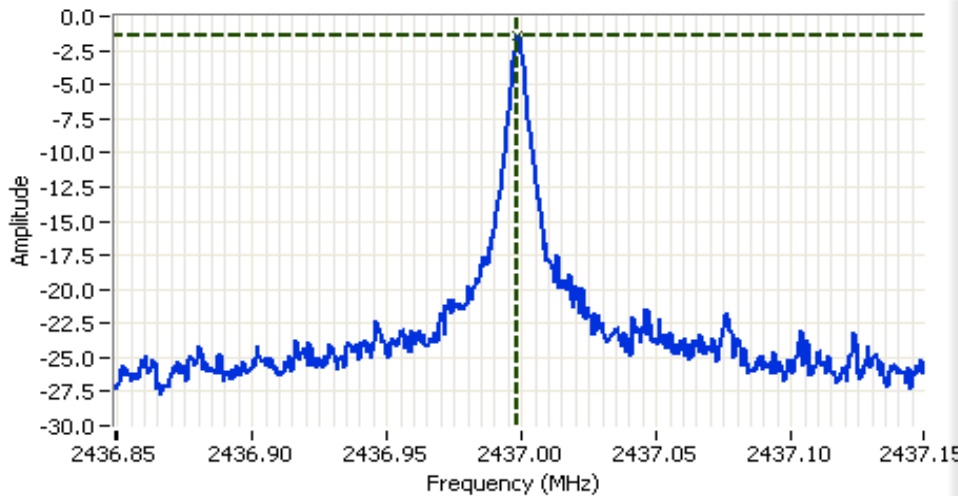

Analyzer Settings
 HP8564E,006,EMI,UK6
 CF: 2436.999 MHz
 SPAN:300 kHz
 RB 3.00 kHz
 VB 10.00 kHz
 Detector POS
 Att 10
 RL Offset 8.00
 Sweep Time 100.0s
 Ref Lvl:1.80DBM

Comments
 PSD: -1.4 dBm/3kHz
 802.11n 40MHz
 Chain C

Cursor 1 2436.9985 -1.37

0.0000 0.00

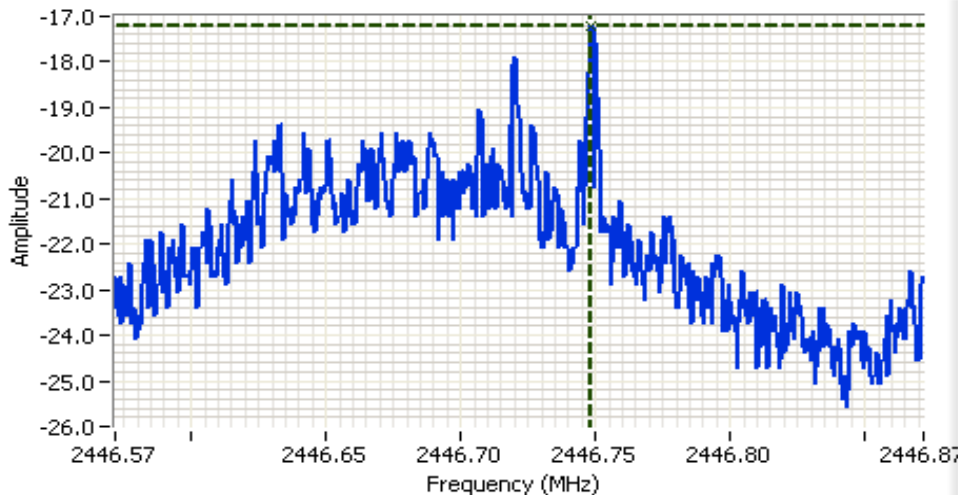

Analyzer Settings
 HP8564E,006,EMI,UK6
 CF: 2446.722 MHz
 SPAN:300 kHz
 RB 3.00 kHz
 VB 10.00 kHz
 Detector POS
 Att 10
 RL Offset 8.00
 Sweep Time 100.0s
 Ref Lvl:-11.90DBM

Comments
 PSD: -17.2 dBm/3kHz
 802.11n 40MHz
 Chain A

Cursor 1 2446.7482 -17.23

0.0000 0.00



Client: Xirus	Job Number: J71456
Model: XN-16 and XN-8	T-Log Number: T71643
Contact: Steve Smith	Account Manager: Susan Pezli
Standard: -	Class: N/A

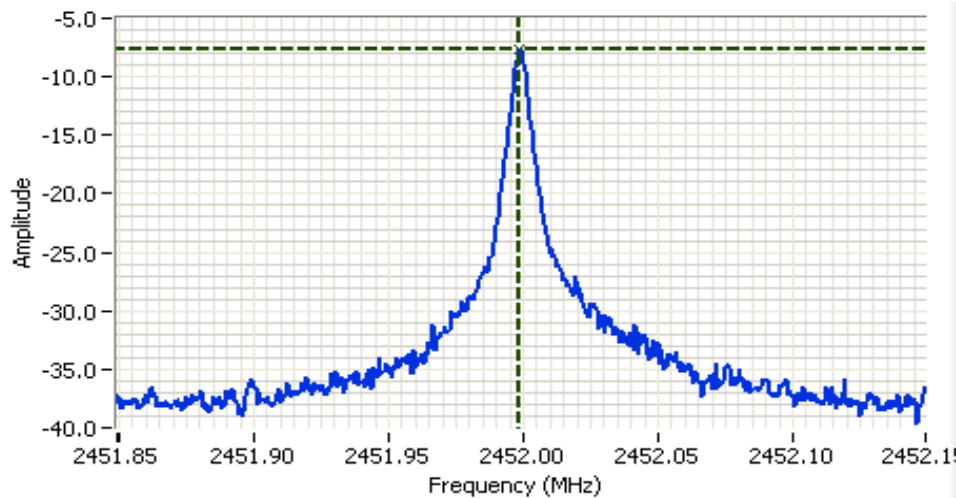

Analyzer Settings
 HP8564E,006,EMI,UK6
 CF: 2451.999 MHz
 SPAN:300 kHz
 RB 3.00 kHz
 VB 10.00 kHz
 Detector POS
 Att 10
 RL Offset 8.00
 Sweep Time 100.0s
 Ref Lvl:-2.80DBM

Comments
 PSD: -7.6 dBm/3kHz
 802.11n 40MHz
 Chain B

Cursor 1 2451.9988 -7.63

0.0000 0.00

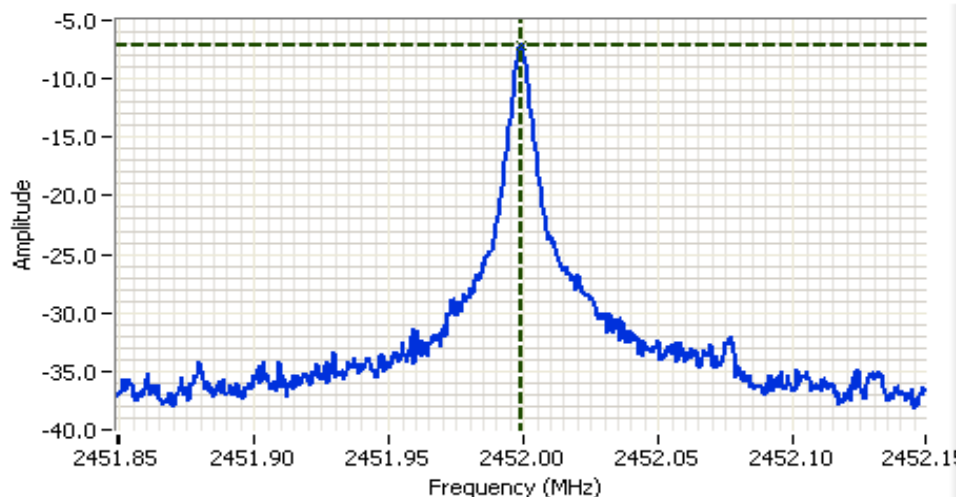

Analyzer Settings
 HP8564E,006,EMI,UK6
 CF: 2451.999 MHz
 SPAN:300 kHz
 RB 3.00 kHz
 VB 10.00 kHz
 Detector POS
 Att 10
 RL Offset 8.00
 Sweep Time 100.0s
 Ref Lvl:-2.80DBM

Comments
 PSD: -7.1 dBm/3kHz
 802.11n 40MHz
 Chain C

Cursor 1 2451.9990 -7.13

0.0000 0.00



Client: Xirrus	Job Number: J71456
Model: XN-16 and XN-8	T-Log Number: T71643
	Account Manager: Susan Pezli
Contact: Steve Smith	
Standard: -	Class: N/A

Run #3: Signal Bandwidth

Power Setting	Frequency (MHz)	Resolution Bandwidth	Bandwidth (MHz)	
			6dB	99%
13.0	2412 802.11n20	100kHz	17.8	18.3
20.0	2437 802.11n20	100kHz	17.8	18.3
9.5	2462 802.11n20	100kHz	17.8	18.2
8.0	2422 802.11n40	100kHz	36.4	37.0
20.0	2437 802.11n40	100kHz	35.7	37.1
9.0	2452 802.11n40	100kHz	35.5	37.0

Note 1: Measured on each chain

Note 2: 99% bandwidth measured in accordance with RSS GEN, with RB > 1% of the span and VB > 3xRB

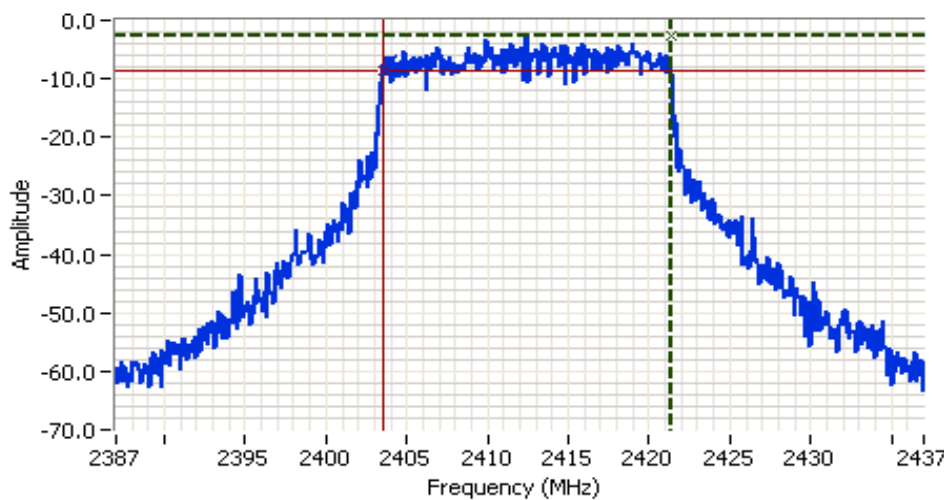

Analyzer Settings

HP8564E,006,EMI,UK6
 CF: 2412.000 MHz
 SPAN:50.000 MHz
 RB 100 kHz
 VB 100 kHz
 Detector POS
 Att 10
 RL Offset 8.00
 Sweep Time 50.0ms
 Ref Lvl:2.80DBM

Comments

6dB BW: 17.833 MHz
 802.11n 20MHz
 Chain B

Cursor 1	2421.3333	-2.70	
Cursor 2	2403.5000	-8.70	

Delta Freq. 17.833
 Delta Amplitude 6.00



Client: Xirrus	Job Number: J71456
Model: XN-16 and XN-8	T-Log Number: T71643
Contact: Steve Smith	Account Manager: Susan Pezli
Standard: -	Class: N/A

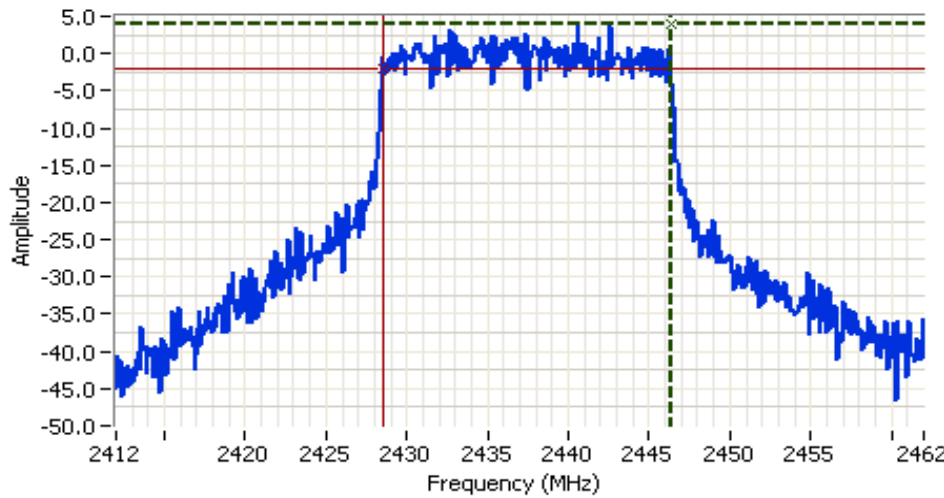

Analyzer Settings
 HP8564E,006,EMI,UK6
 CF: 2437.000 MHz
 SPAN:50.000 MHz
 RB 100 kHz
 VB 100 kHz
 Detector POS
 Att 10
 RL Offset 8.00
 Sweep Time 50.0ms
 Ref Lvl:7.80DBM

Comments
 6dB BW: 17.833 MHz
 802.11n 20MHz
 Chain B

Cursor 1 2446.3333 3.97

Cursor 2 2428.5000 -2.03

Delta Freq. 17.833

Delta Amplitude 6.00

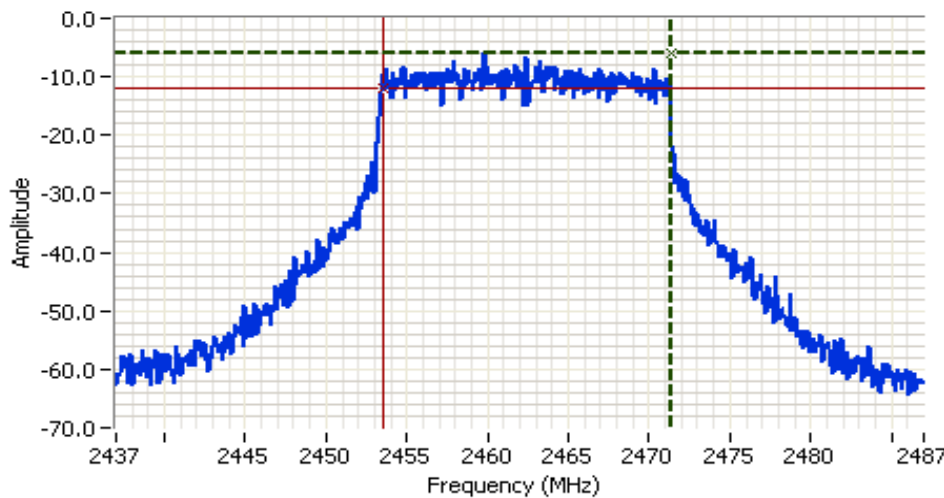

Analyzer Settings
 HP8564E,006,EMI,UK6
 CF: 2462.000 MHz
 SPAN:50.000 MHz
 RB 100 kHz
 VB 100 kHz
 Detector POS
 Att 10
 RL Offset 8.00
 Sweep Time 50.0ms
 Ref Lvl:-0.20DBM

Comments
 6dB BW: 17.833 MHz
 802.11n 20MHz
 Chain B

Cursor 1 2471.3333 -6.03

Cursor 2 2453.5000 -12.03

Delta Freq. 17.833

Delta Amplitude 6.00



Client: Xirrus	Job Number: J71456
Model: XN-16 and XN-8	T-Log Number: T71643
Contact: Steve Smith	Account Manager: Susan Pezli
Standard: -	Class: N/A

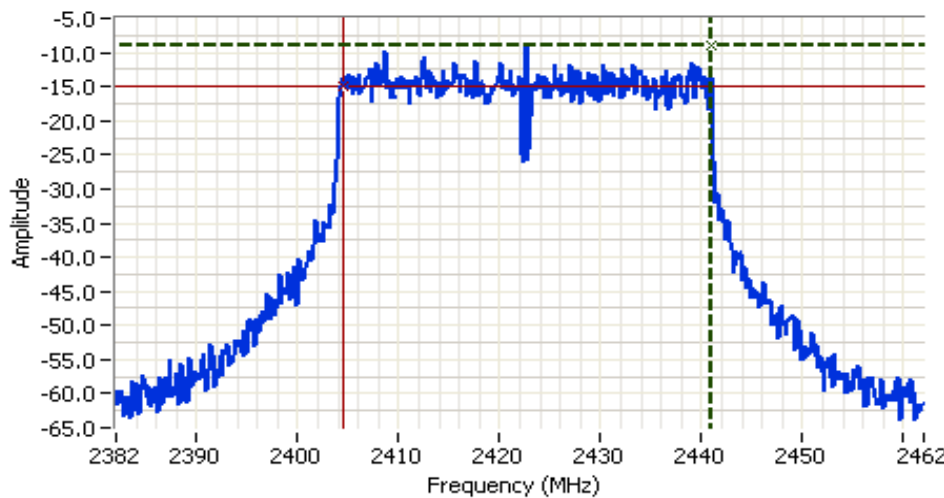

Analyzer Settings
 HP8564E,006,EMI,UK6
 CF: 2422.000 MHz
 SPAN:80.000 MHz
 RB 100 kHz
 VB 100 kHz
 Detector POS
 Att 10
 RL Offset 8.00
 Sweep Time 50.0ms
 Ref Lvl:-2.80DBM

Comments
 6dB BW: 36.400 MHz
 802.11n 40MHz
 Chain B

Cursor 1 2440.9333 -8.97

Cursor 2 2404.5333 -14.97

Delta Freq. 36.400

Delta Amplitude 6.00

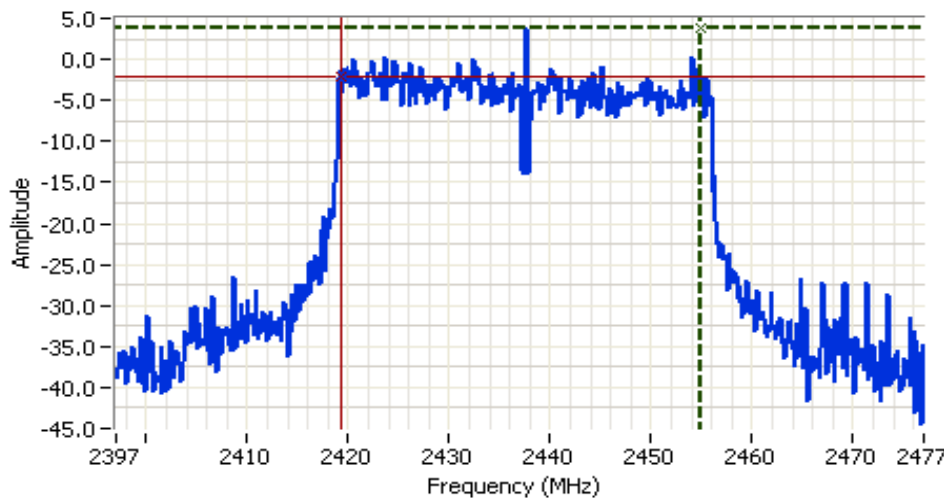

Analyzer Settings
 HP8564E,006,EMI,UK6
 CF: 2437.000 MHz
 SPAN:80.000 MHz
 RB 100 kHz
 VB 100 kHz
 Detector POS
 Att 10
 RL Offset 8.00
 Sweep Time 50.0ms
 Ref Lvl:7.60DBM

Comments
 6dB BW: 35.733 MHz
 802.11n 40MHz
 Chain B

Cursor 1 2455.0000 3.93

Cursor 2 2419.2667 -2.07

Delta Freq. 35.733

Delta Amplitude 6.00



Client: Xirrus	Job Number: J71456
Model: XN-16 and XN-8	T-Log Number: T71643
Contact: Steve Smith	Account Manager: Susan Pezli
Standard: -	Class: N/A

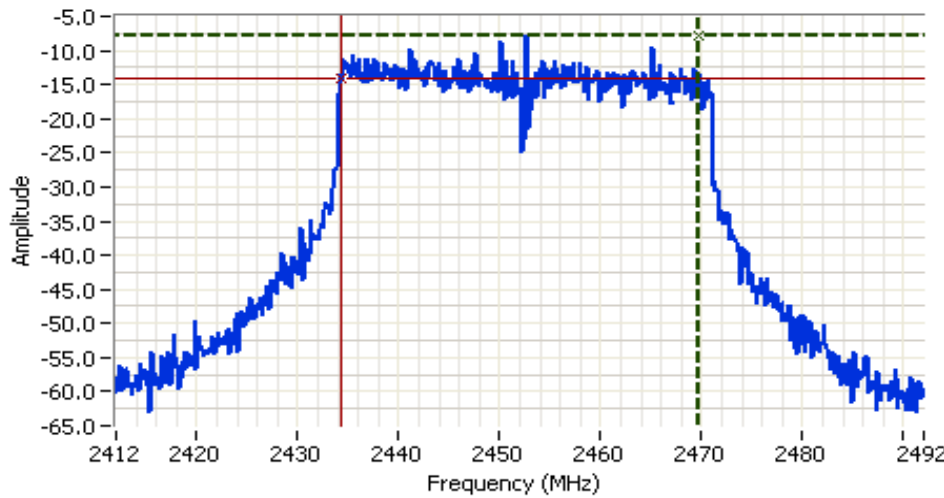

Analyzer Settings

HP8564E,006,EMI,UK6
 CF: 2452.000 MHz
 SPAN:80.000 MHz
 RB 100 kHz
 VB 100 kHz
 Detector POS
 Att 10
 RL Offset 8.00
 Sweep Time 50.0ms
 Ref Lvl:-2.80DBM

Comments

6dB BW: 35.467 MHz
 802.11n 40MHz
 Chain B

Cursor 1 2469.7333 -7.97 ⊕ ⊖ ⊞ ⊚ Delta Freq. 35.467

Cursor 2 2434.2667 -13.97 ⊕ ⊖ ⊞ ⊚ Delta Amplitude 6.00



Run #4: Out of Band Spurious Emissions

Power Setting Per Chain				Frequency (MHz)	Limit	Result
#1	#2	#3	#4			
13.0	13.0	13.0		2412 802.11n20	-30dBc	Pass
20.0	20.0	20.0		2437 802.11n20	-30dBc	Pass
9.5	9.5	9.5		2462 802.11n20	-30dBc	Pass
8.0	8.0	8.0		2422 802.11n40	-30dBc	Pass
20.0	20.0	20.0		2437 802.11n40	-30dBc	Pass
9.0	9.0	9.0		2452 802.11n40	-30dBc	Pass

Note 1: Measured with all chains connected together through a combiner, unused ports on the combiner terminated in 50ohms.
 Note 2: Measured using RB>=100kHz, VB>= RB

Client: Xirrus	Job Number: J71456
Model: XN-16 and XN-8	T-Log Number: T71643
	Account Manager: Susan Pezli
Contact: Steve Smith	
Standard: -	Class: N/A

Plots for low channel - 802.11n20 -, power setting(s) = 13.0

Out Of Band Spurious Emissions - 2412 MHz (802.11n 20MHz)

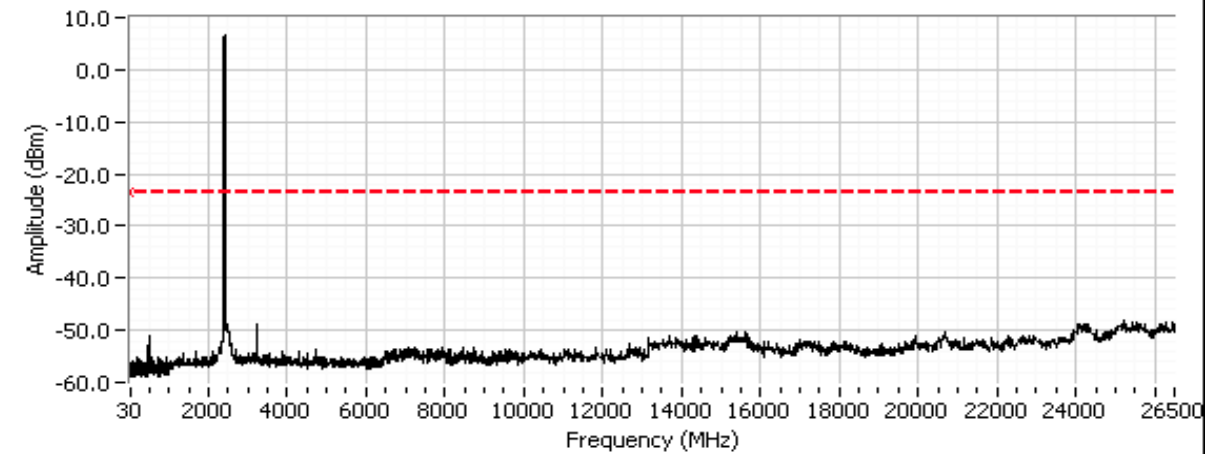

Out Of Band Spurious Emissions - 2412 MHz (802.11n 20MHz)

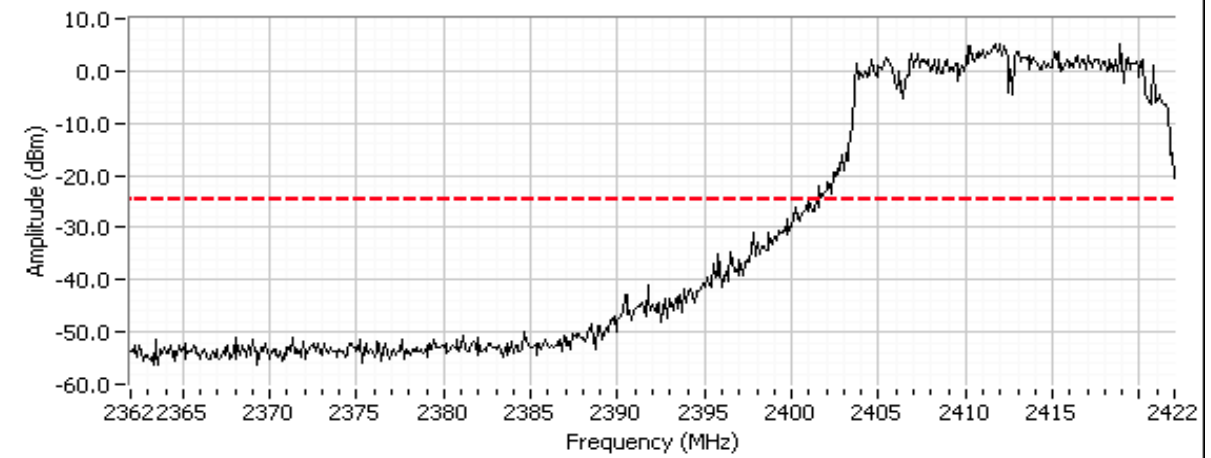

Client: Xirrus	Job Number: J71456
Model: XN-16 and XN-8	T-Log Number: T71643
	Account Manager: Susan Pezli
Contact: Steve Smith	
Standard: -	Class: N/A

Plots for center channel - 802.11n20 - , power setting(s) = 20.0

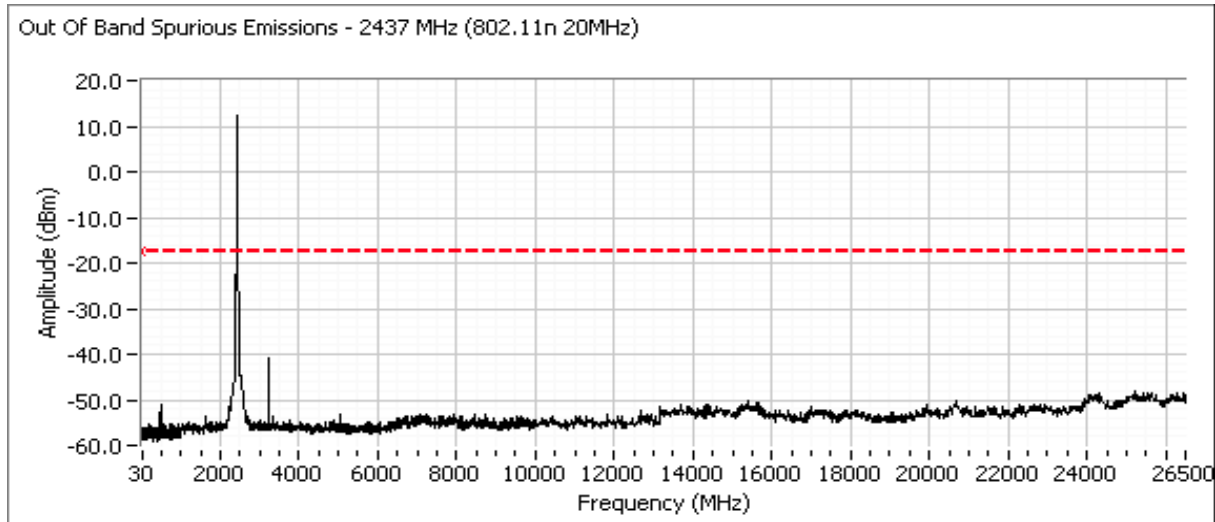

Plots for high channel - 802.11n20 - , power setting(s) = 9.5

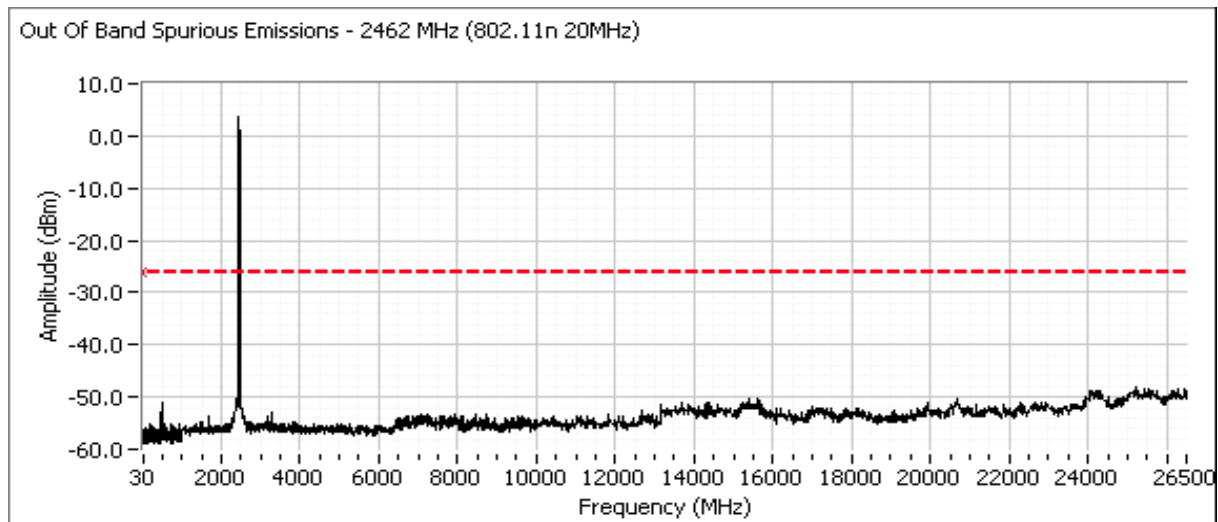

Client: Xirrus	Job Number: J71456
Model: XN-16 and XN-8	T-Log Number: T71643
	Account Manager: Susan Pezli
Contact: Steve Smith	
Standard: -	Class: N/A

Plots for low channel - 802.11n40 - , power setting(s) = 8.0

Out Of Band Spurious Emissions - 2412 MHz (802.11n 40MHz)

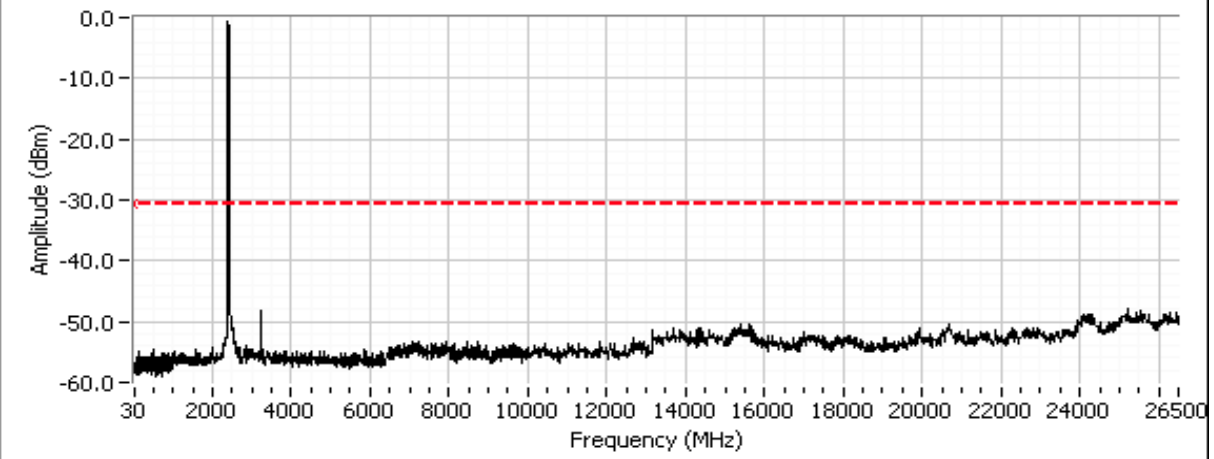

Out Of Band Spurious Emissions - 2412 MHz (802.11n 40MHz)

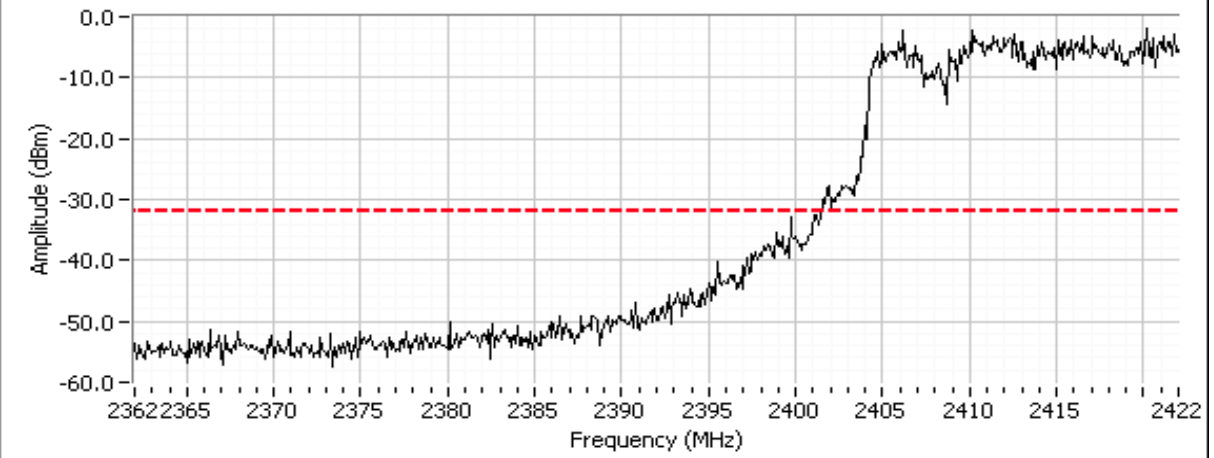

Client: Xirrus	Job Number: J71456
Model: XN-16 and XN-8	T-Log Number: T71643
	Account Manager: Susan Pezli
Contact: Steve Smith	
Standard: -	Class: N/A

Plots for center channel - 802.11n40 - , power setting(s) = 20.0

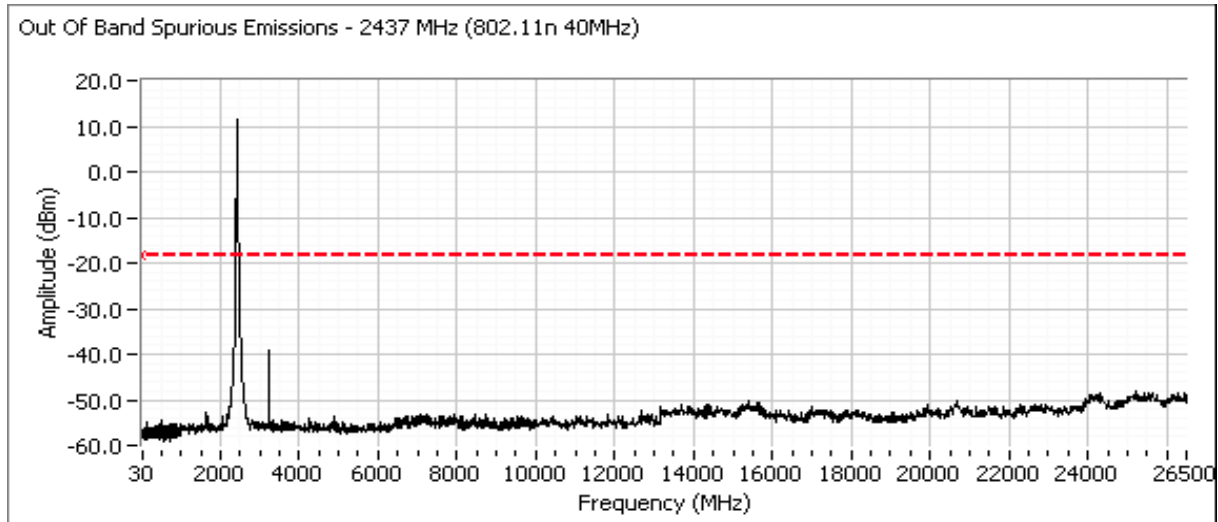

Plots for high channel - 802.11n40 - , power setting(s) = 9.0

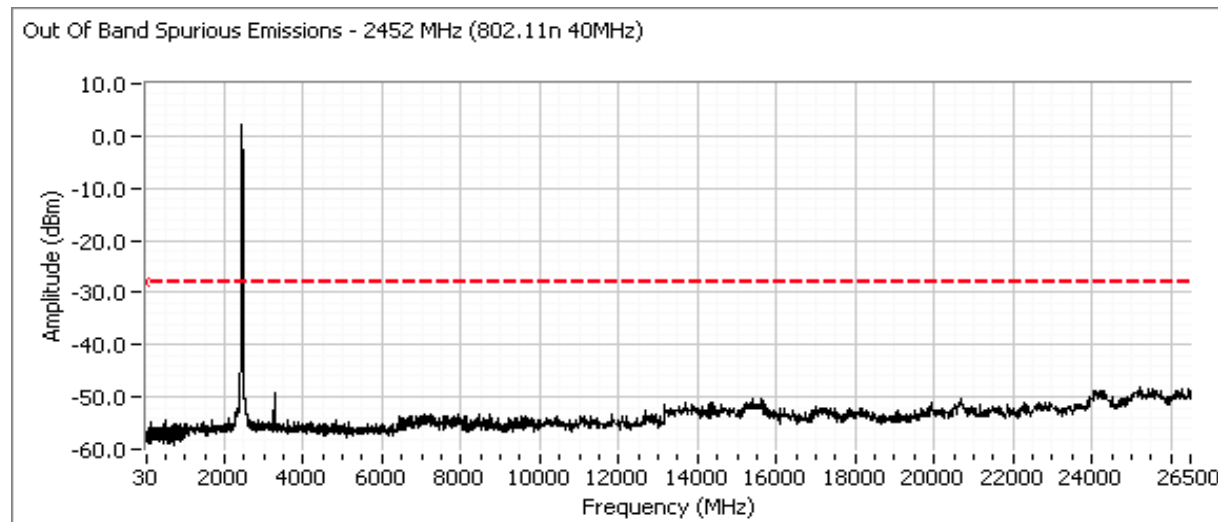

Client: Xirrus	Job Number: J71456
Model: XN-16 and XN-8	T-Log Number: T71643
	Account Manager: Susan Pelzi
Contact: Steve Smith	
Standard: -	Class: N/A

RSS 210 and FCC 15.247 (DTS) Antenna Port Measurements Power, PSD, Bandwidth and Spurious Emissions

Test Specific Details

Objective: The objective of this test session is to perform final qualification testing of the EUT with respect to the specification listed above.

Date of Test: 6/4/2008
 Test Engineer: Suhaila Khushzad
 Test Location: OATS # 1

Config. Used: 1
 Config Change: None
 EUT Voltage: POE

General Test Configuration

The EUT was connected to the spectrum analyzer or power meter via a suitable attenuator. All measurements were made on a single chain.

All measurements have been corrected to allow for the external attenuators used.

Ambient Conditions:

Temperature: 19 °C
 Rel. Humidity: 46 %

Summary of Results

Run #	Test Performed	Limit	Pass / Fail	Result / Margin
1	Output Power	15.247(b)	Pass	802.11a: 15.1 dBm
2	PSD	15.247(d)	Pass	802.11a: -8 dBm/3kHz
3	Minimum 6dB Bandwidth	15.247(a)	Pass	802.11a: 16.33 MHz
3	99% Bandwidth	RSS GEN	-	802.11a: 17.4 MHz
4	Spurious emissions	15.247(b)	Pass	All signal were more than 30dB below the fundamental

Modifications Made During Testing

No modifications were made to the EUT during testing

Deviations From The Standard

No deviations were made from the requirements of the standard.

Client: Xirrus	Job Number: J71456
Model: XN-16 and XN-8	T-Log Number: T71643
	Account Manager: Susan Pezli
Contact: Steve Smith	
Standard: -	Class: N/A

Run #1: Output Power
802.11a - Single Radio In the Band

Power Setting ²	Frequency (MHz)	Output Power		Antenna Gain (dBi)	Result	EIRP ^{Note 2}	
		(dBm) ¹	mW			dBm	W
17	5745	14.6	28.8	6.0	Pass	20.6	0.115
17	5785	14.6	28.8	6.0	Pass	20.6	0.115
17	5825	15.1	32.5	6.0	Pass	21.1	0.129

802.11a - Five radios on non-overlapping channels, note 3

Power Setting ²	Frequency (MHz)	Output Power per radio		Total Power		Antenna Gain (dBi)	Result	EIRP ^{Note 2}	
		(dBm) ¹	mW	dBm	mW			dBm	W
17	-	15.1	32.5	22.1	162.5	6.0	Pass	28.1	0.647

Note 1:	Output power measured using a spectrum analyzer (see plots below): RBW=1MHz, VB=3 MHz, sample detector, power averaging on (transmitted signal was continuous) and power integration over 50 MHz. Spurious limit is -30dBc because this method was used. The output power limit is 30dBm.
Note 2:	Power setting - the software power setting used during testing, included for reference only.
Note 3:	The device has multiple radios, but the software limits operation in any band to ensure only non-overlapping channels are used (no two radios can operate on the same channel or on overlapping channels). In the 5745 - 5785 MHz band there can be a maximum of 5 radios active (5, non-overlapping 802.11a channels). The calculated total power (obtained by multiplying the output power on a single radio by the number of radios that can be operating in the band) demonstrates that, with 5 radios active, the total output power still complies with the limit.

Client: Xirrus	Job Number: J71456
Model: XN-16 and XN-8	T-Log Number: T71643
Contact: Steve Smith	Account Manager: Susan Pezli
Standard: -	Class: N/A

Run #1: Output Power - Single Radio In the Band

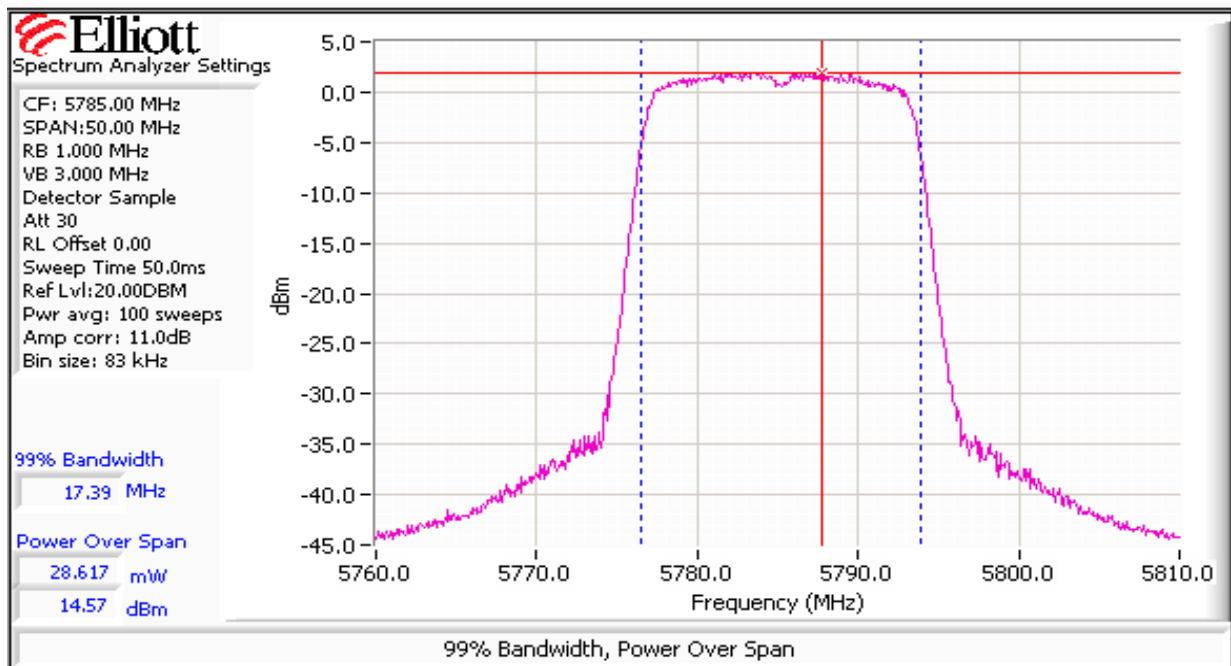
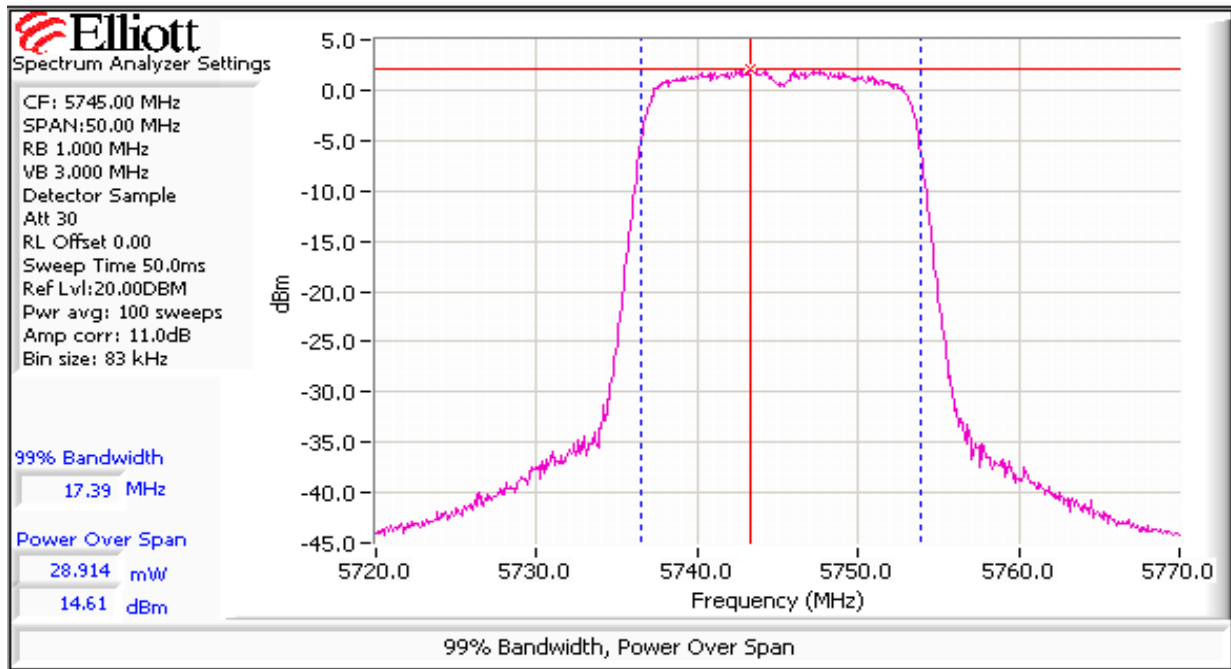

Client: Xirrus	Job Number: J71456
Model: XN-16 and XN-8	T-Log Number: T71643
Contact: Steve Smith	Account Manager: Susan Pezli
Standard: -	Class: N/A

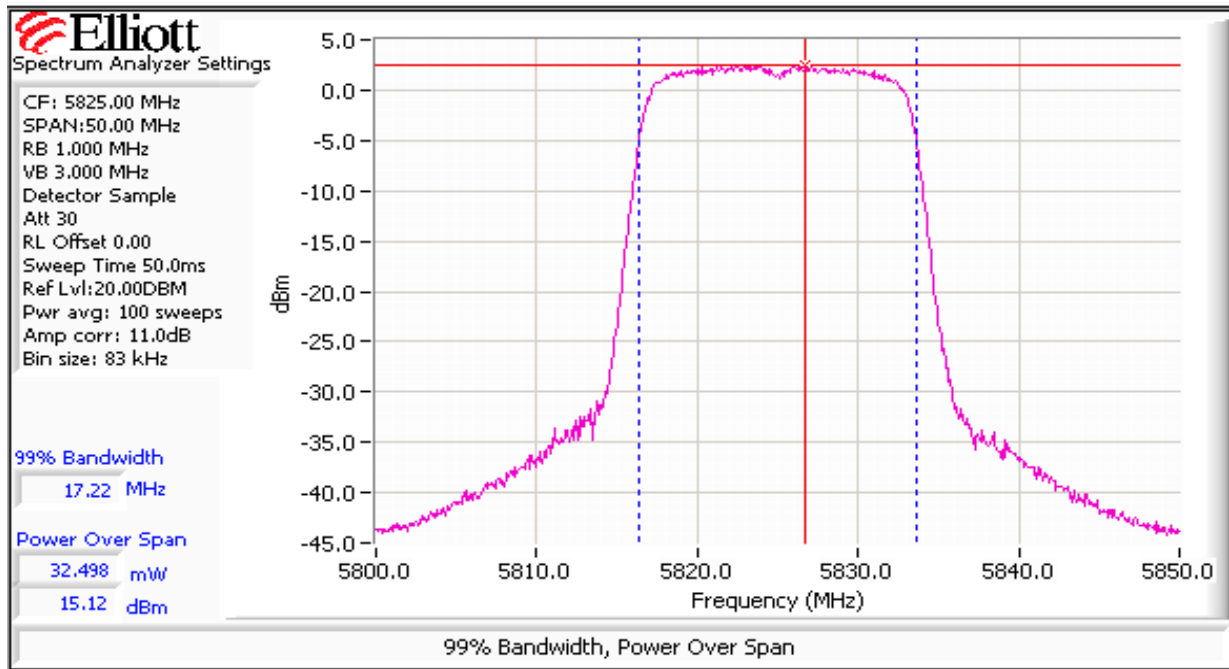
Run #1: Output Power - Single Radio In the Band

Client: Xirrus	Job Number: J71456
Model: XN-16 and XN-8	T-Log Number: T71643
	Account Manager: Susan Pezl
Contact: Steve Smith	
Standard: -	Class: N/A

**Run #2: Power spectral Density
802.11a**

Power Setting	Frequency (MHz)	PSD	Limit dBm/3kHz	Result
		(dBm/3kHz) ^{Note 1}		
17	5745	-10.0	8.0	Pass
17	5785	-9.8	8.0	Pass
17	5825	-8.0	8.0	Pass

Note 1: Power spectral density measured using RB=3 kHz, VB=10kHz, analyzer with peak detector and with a sweep time set to ensure a dwell time of at least 1 second per 3kHz. The measurement is made at the frequency of PPSD determined from preliminary scans using RB=3kHz using multiple sweeps at a faster rate over the 6dB bandwidth of the signal.

Note 2: The operation of multiple radios in the band does not affect power spectral density as radios cannot operate on overlapping channels.

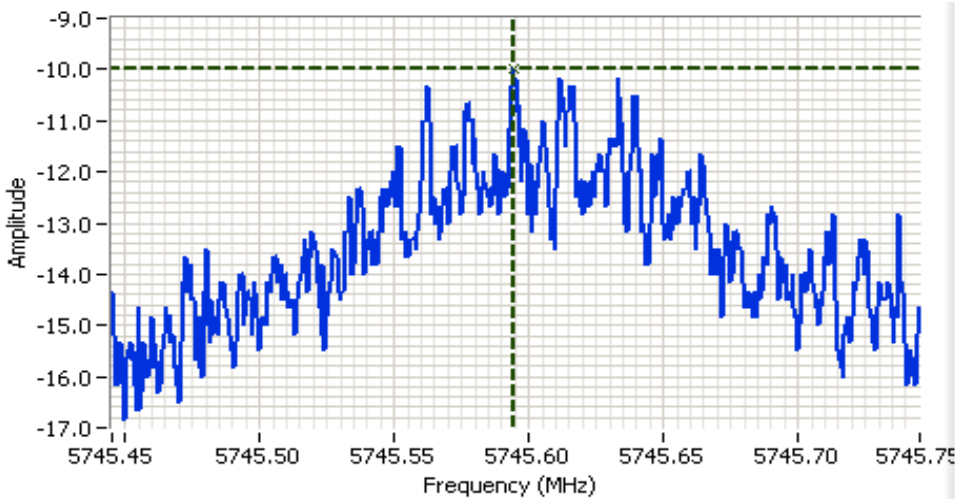



Analyzer Settings

HP8564E
 CF: 5745.595 MHz
 SPAN: 300 kHz
 RB 3.00 kHz
 VB 10.00 kHz
 Detector POS
 Att 10
 RL Offset 11.00
 Sweep Time 100.0s
 Ref Lvl: 11.00DBM

Comments

PSD: -10dBm/3kHz
 802.11a Single Chain
 5745 MHz

Cursor 1 5745.5942 -10.00 

0.0000 0.00 



Client: Xirrus	Job Number: J71456
Model: XN-16 and XN-8	T-Log Number: T71643
Contact: Steve Smith	Account Manager: Susan Pezli
Standard: -	Class: N/A

Run #2: Power spectral Density
802.11a

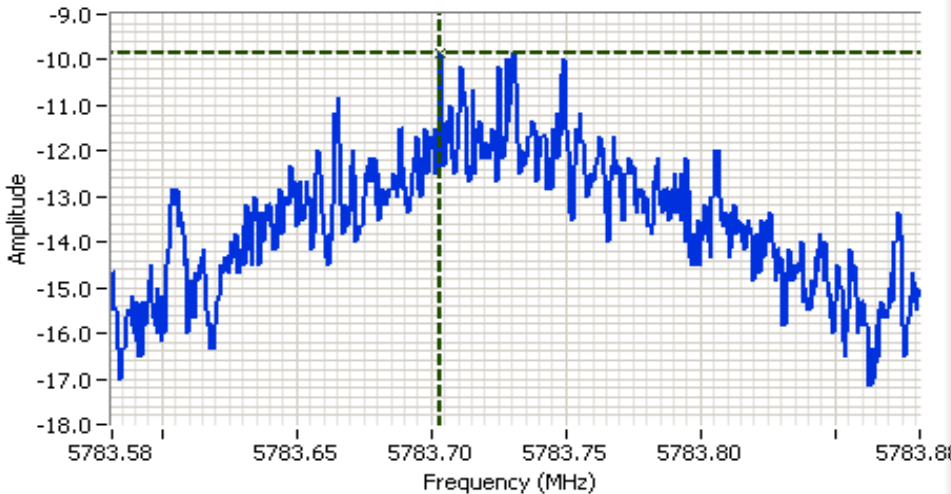

Analyzer Settings
 HP8564E
 CF: 5783.731 MHz
 SPAN:300 kHz
 RB 3.00 kHz
 VB 10.00 kHz
 Detector POS
 Att 10
 RL Offset 11.00
 Sweep Time 100.0s
 Ref Lvl:11.00DBM

Comments
 PSD: -9.83dBm/3kHz
 802.11a Single Chain
 5785 MHz

Cursor 1 5783.7034 -9.83

0.0000 0.00

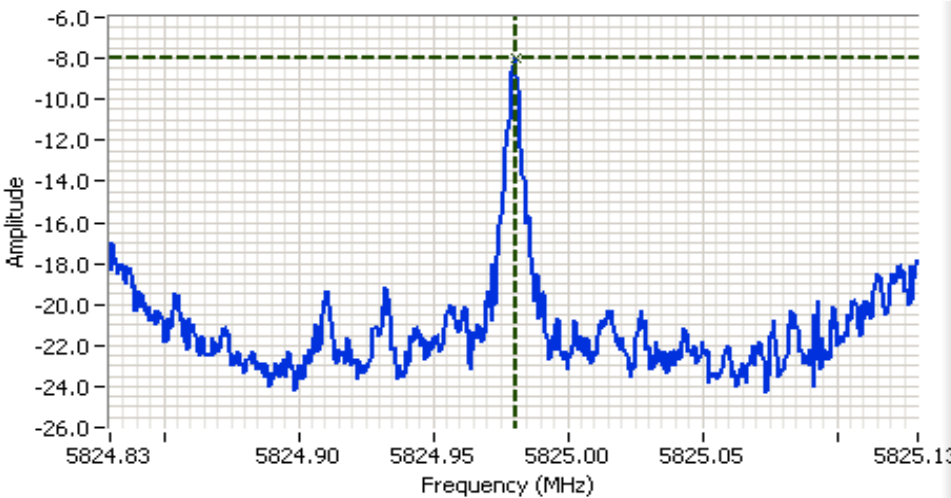

Analyzer Settings
 HP8564E
 CF: 5824.980 MHz
 SPAN:300 kHz
 RB 3.00 kHz
 VB 10.00 kHz
 Detector POS
 Att 10
 RL Offset 11.00
 Sweep Time 100.0s
 Ref Lvl:11.00DBM

Comments
 PSD: -8dBm/3kHz
 802.11a Single Chain
 5825 MHz

Cursor 1 5824.9805 -8.00

0.0000 0.00



Client: Xirrus	Job Number: J71456
Model: XN-16 and XN-8	T-Log Number: T71643
Contact: Steve Smith	Account Manager: Susan Pezli
Standard: -	Class: N/A

Run #3: Signal Bandwidth

Mode	Power Setting	Frequency (MHz)	Resolution Bandwidth	Bandwidth (MHz)	
				6dB	99%
802.11a	17	5745	100k	16.42	17.4
802.11a	17	5785	100k	16.42	17.4
802.11a	17	5825	100k	16.33	17.2

Note 1: 99% bandwidth measured in accordance with RSS GEN, with RB > 1% of the span and VB > 3xRB

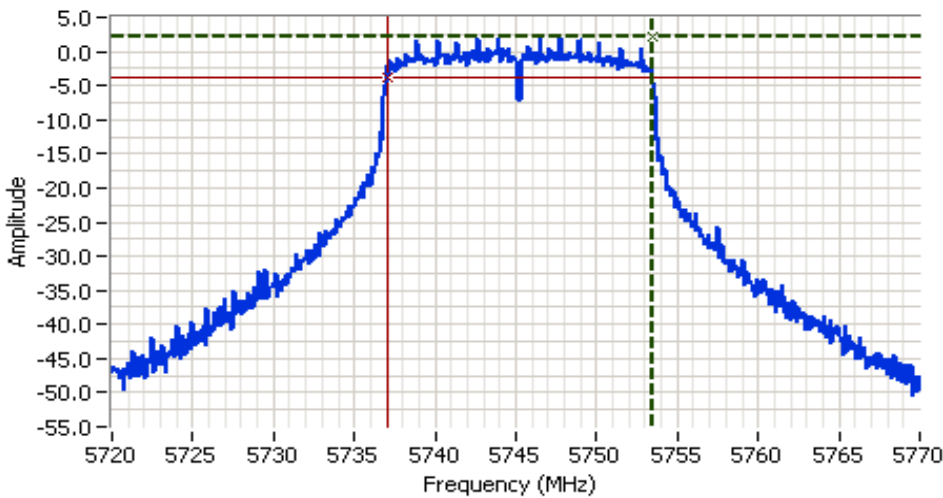

Analyzer Settings

HP8564E
 CF: 5745.000 MHz
 SPAN: 50.000 MHz
 RB 100 kHz
 VB 100 kHz
 Detector POS
 Att 10
 RL Offset 11.00
 Sweep Time 50.0ms
 Ref Lvl: 11.00DBM

Comments

6dB BW: 16.417 MHz
 80211a Single Chain

Cursor 1	5753.4167	2.17	
Cursor 2	5737.0000	-3.83	

Delta Freq. 16.417
 Delta Amplitude 6.00



Client: Xirrus	Job Number: J71456
Model: XN-16 and XN-8	T-Log Number: T71643
Contact: Steve Smith	Account Manager: Susan Pezli
Standard: -	Class: N/A

Run #3: Signal Bandwidth

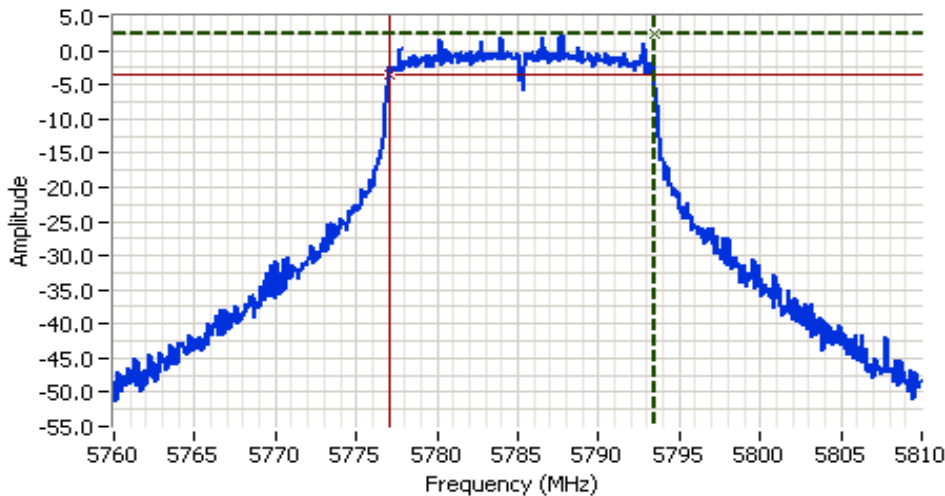

Analyzer Settings

HP8564E
 CF: 5785.000 MHz
 SPAN:50.000 MHz
 RB 100 kHz
 VB 100 kHz
 Detector POS
 Att 10
 RL Offset 11.00
 Sweep Time 50.0ms
 Ref Lvl:11.00DBM

Comments

6dB BW: 16.417 MHz
 80211a Single Chain

Cursor 1 5793.4167 2.33
 Cursor 2 5777.0000 -3.67

Delta Freq. 16.417

Delta Amplitude 6.00

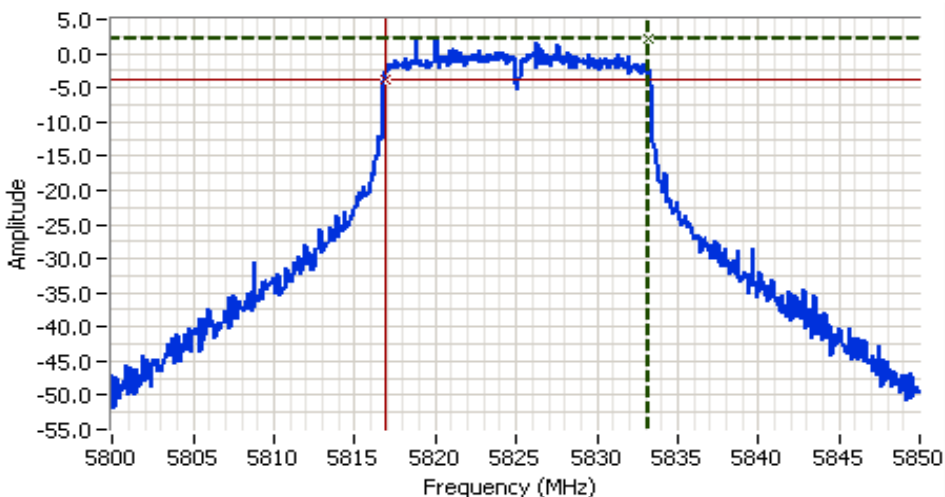

Analyzer Settings

HP8564E
 CF: 5824.980 MHz
 SPAN:50.000 MHz
 RB 100 kHz
 VB 100 kHz
 Detector POS
 Att 10
 RL Offset 11.00
 Sweep Time 50.0ms
 Ref Lvl:11.00DBM

Comments

6dB BW: 16.333 MHz
 80211a Single Chain

Cursor 1 5833.2300 2.17
 Cursor 2 5816.8966 -3.83

Delta Freq. 16.333

Delta Amplitude 6.00



Client: Xirrus	Job Number: J71456
Model: XN-16 and XN-8	T-Log Number: T71643
Contact: Steve Smith	Account Manager: Susan Pezli
Standard: -	Class: N/A

Run #4: Out of Band Spurious Emissions

Measured using RBW>=100kHz, VBW>= RB

Frequency (MHz)	Limit	Result
5745	-30dBc	Pass
5785	-30dBc	Pass
5825	-30dBc	Pass

Plots for low channel - 802.11a - , power setting(s) = 17

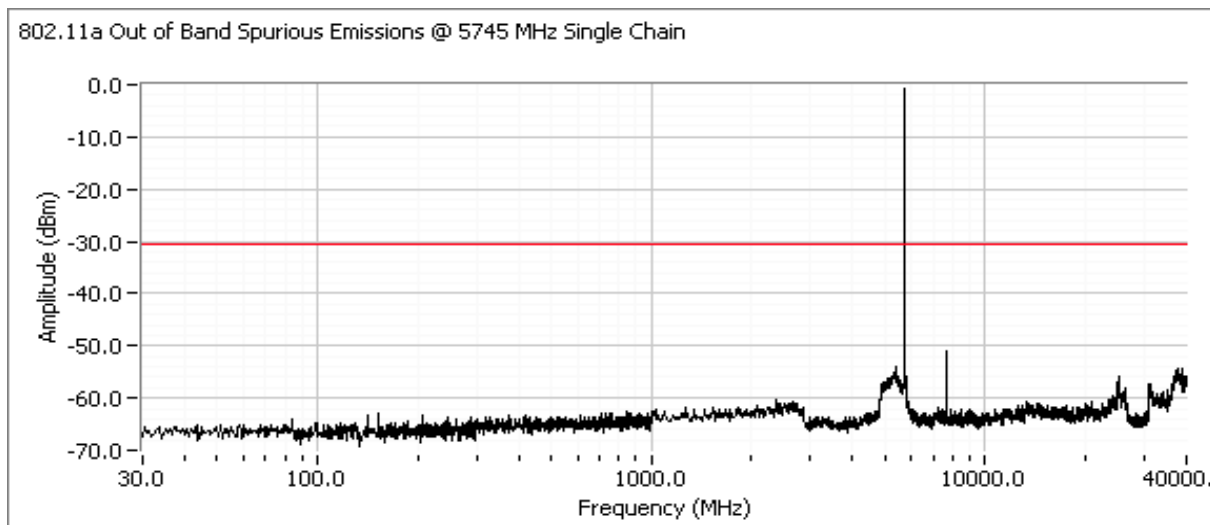

Additional plot showing compliance with -30dBc limit at 5725 MHz

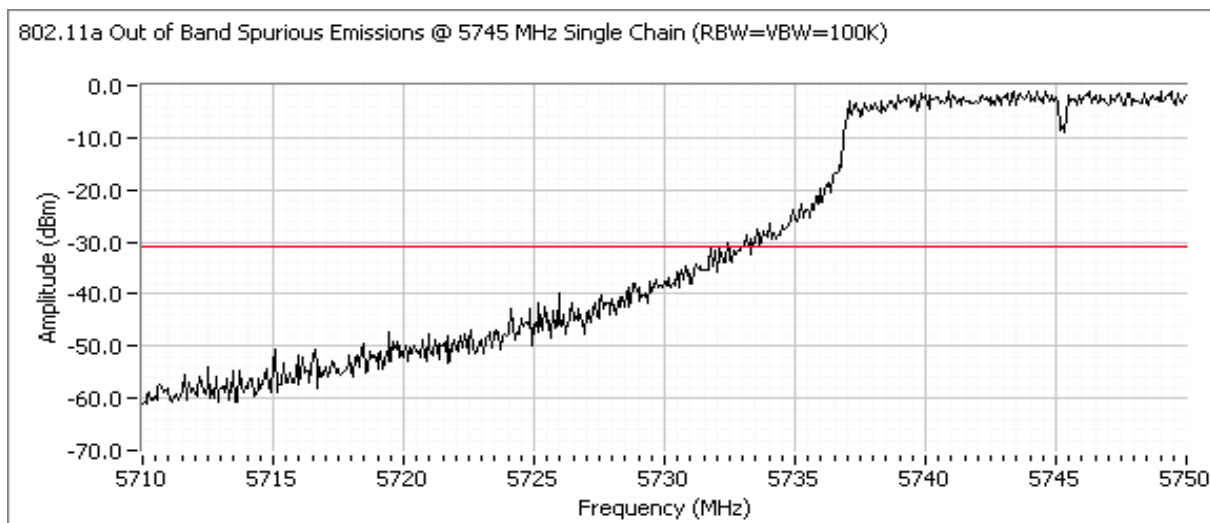

Client: Xirrus	Job Number: J71456
Model: XN-16 and XN-8	T-Log Number: T71643
	Account Manager: Susan Pezli
Contact: Steve Smith	
Standard: -	Class: N/A

Run #4: Out of Band Spurious Emissions

Plots for center channel - 802.11a - , power setting(s) = 17

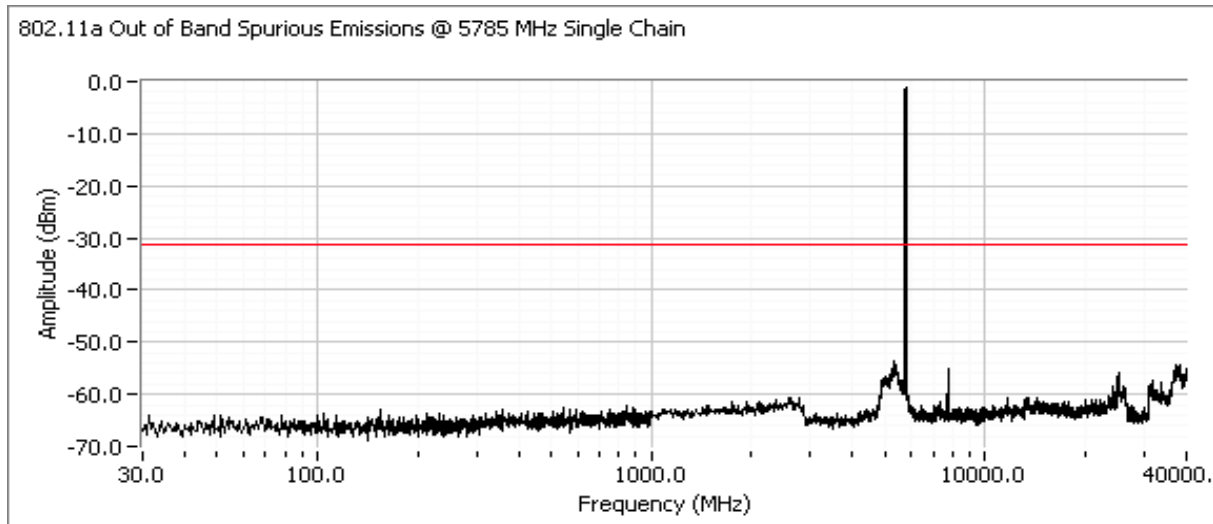

Plots for high channel - 802.11a - , power setting(s) = 17

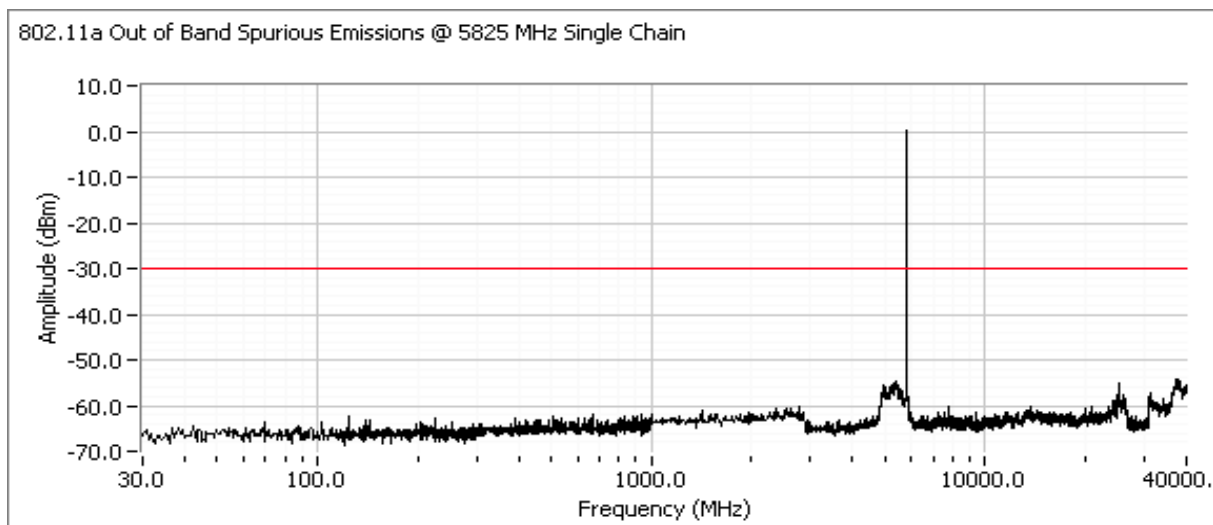

Client: Xirrus	Job Number: J71456
Model: XN-16 and XN-8	T-Log Number: T71643
	Account Manager: Susan Pezli
Contact: Steve Smith	
Standard: -	Class: N/A

Additional plot showing compliance with -30dBc limit at 5850 MHz

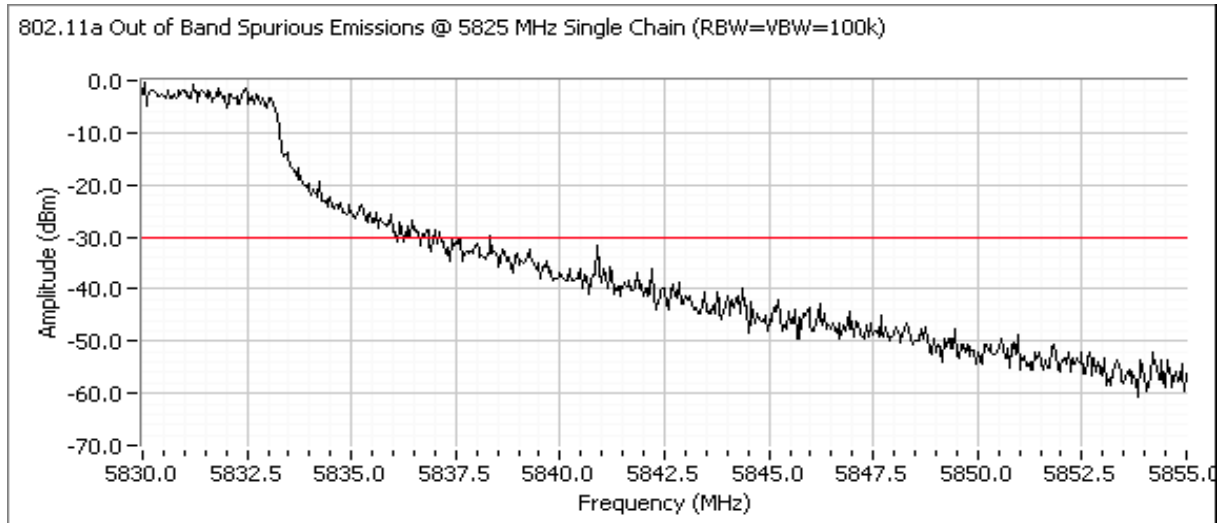

Client: Xirrus	Job Number: J71456
Model: XN-16 and XN-8	T-Log Number: T71643
	Account Manager: Susan Pezli
Contact: Steve Smith	
Standard: -	Class: N/A

RSS 210 and FCC 15.247 (DTS) Antenna Port Measurements MIMO and Smart Antenna Systems Power, PSD, Bandwidth and Spurious Emissions

Test Specific Details

Objective: The objective of this test session is to perform final qualification testing of the EUT with respect to the specification listed above.

Date of Test: 6/4&6/2008
Test Engineer: Suhaila Khushzad
Test Location: OATS # 1

Config. Used: 1
Config Change: None
EUT Voltage: POE

General Test Configuration

The EUT was connected to the spectrum analyzer or power meter via a suitable attenuator. All measurements were made on a single chain.

All measurements have been corrected to allow for the external attenuators used.

Ambient Conditions:

Temperature: 19 °C
Rel. Humidity: 46 %

Summary of Results

Run #	Test Performed	Limit	Pass / Fail	Result / Margin
1	Output Power Chain A+C	15.247(b)	Pass	802.11a: 17.5 dBm
2	PSD Chain A+C	15.247(d)	Pass	802.11a: -7 dBm/3kHz
3	Minimum 6dB Bandwidth	15.247(a)	Pass	802.11a: 16.42 MHz
3	99% Bandwidth	RSS GEN	Pass	802.11a: 17.4 MHz
4	Spurious emissions	15.247(b)	Pass	All signal were more than 30dB below the fundamental

Modifications Made During Testing

No modifications were made to the EUT during testing

Deviations From The Standard

No deviations were made from the requirements of the standard.

Client: Xirrus	Job Number: J71456
Model: XN-16 and XN-8	T-Log Number: T71643
Contact: Steve Smith	Account Manager: Susan Pezli
Standard: -	Class: N/A

Run #1: Output Power - Chain A + C

Transmitted signal on chain is coherent ? Yes

Single radio Operating in the Band

5745	Chain 1	Chain 2	Chain 3	Chain 4	Total Across All Chains		Limit	
Power Setting ^{Note 3}	17.0		17.0		Total Across All Chains		Limit	
Output Power (dBm) ^{Note 1}	14.7		13.7		17.2 dBm	0.053 W	27.0 dBm	0.500 W
Antenna Gain (dBi) ^{Note 2}	6		6		9.0 dBi		Pass	
eirp (dBm) ^{Note 2}	20.7		19.7		26.2 dBm	0.422 W		

5785	Chain 1	Chain 2	Chain 3	Chain 4	Total Across All Chains		Limit	
Power Setting ^{Note 3}	17.0		17.0		Total Across All Chains		Limit	
Output Power (dBm) ^{Note 1}	14.8		13.4		17.2 dBm	0.052 W	27.0 dBm	0.500 W
Antenna Gain (dBi) ^{Note 2}	6		6		9.0 dBi		Pass	
eirp (dBm) ^{Note 2}	20.8		19.4		26.2 dBm	0.415 W		

5825	Chain 1	Chain 2	Chain 3	Chain 4	Total Across All Chains		Limit	
Power Setting ^{Note 3}	17.0		17.0		Total Across All Chains		Limit	
Output Power (dBm) ^{Note 1}	15.3		13.6		17.5 dBm	0.057 W	27.0 dBm	0.500 W
Antenna Gain (dBi) ^{Note 2}	6		6		9.0 dBi		Pass	
eirp (dBm) ^{Note 2}	21.3		19.6		26.6 dBm	0.452 W		

Five radios on non-overlapping channels, note 3

-	Chain 1	Chain 2	Chain 3	Chain 4	Total Across All Chains		Limit	
Power Setting ^{Note 3}	17.0		17.0		Total Across All Chains		Limit	
Output Power (dBm) ^{Note 1}	15.3		13.6		24.5 dBm	0.284 W	27.0 dBm	0.500 W
Antenna Gain (dBi) ^{Note 2}	6		6		9.0 dBi		Pass	
eirp (dBm) ^{Note 2}	21.3		19.6		33.5 dBm	2.261 W		

Note 1:	Output power measured using a spectrum analyzer (see plots below) with RBW=1MHz, VB=3 MHz, sample detector, power averaging on (transmitted signal was continuous) and power integration over 50 MHz (reference method 1 of FCC DA 02-2138 for U-NII devices, August 30, 2002). Spurious limit becomes -30dBc .
Note 2:	As there is coherency between chains the effective antenna gain is the sum of the individual antenna gains and the eirp is the product of the total power and the effective antenna gain
Note 3:	The device has multiple radios, but the software limits operation in any band to ensure only non-overlapping channels are used (no two radios can operate on the same channel or on overlapping channels). In the 5745 - 5785 MHz band there can be a maximum of 5 radios active (5, non-overlapping 802.11a channels). The calculated total power (obtained by multiplying the output power on a single radio by the number of radios that can be operating in the band) demonstrates that, with 5 radios active, the total output power still complies with the limit.

Client: Xirrus	Job Number: J71456
Model: XN-16 and XN-8	T-Log Number: T71643
Contact: Steve Smith	Account Manager: Susan Pezli
Standard: -	Class: N/A

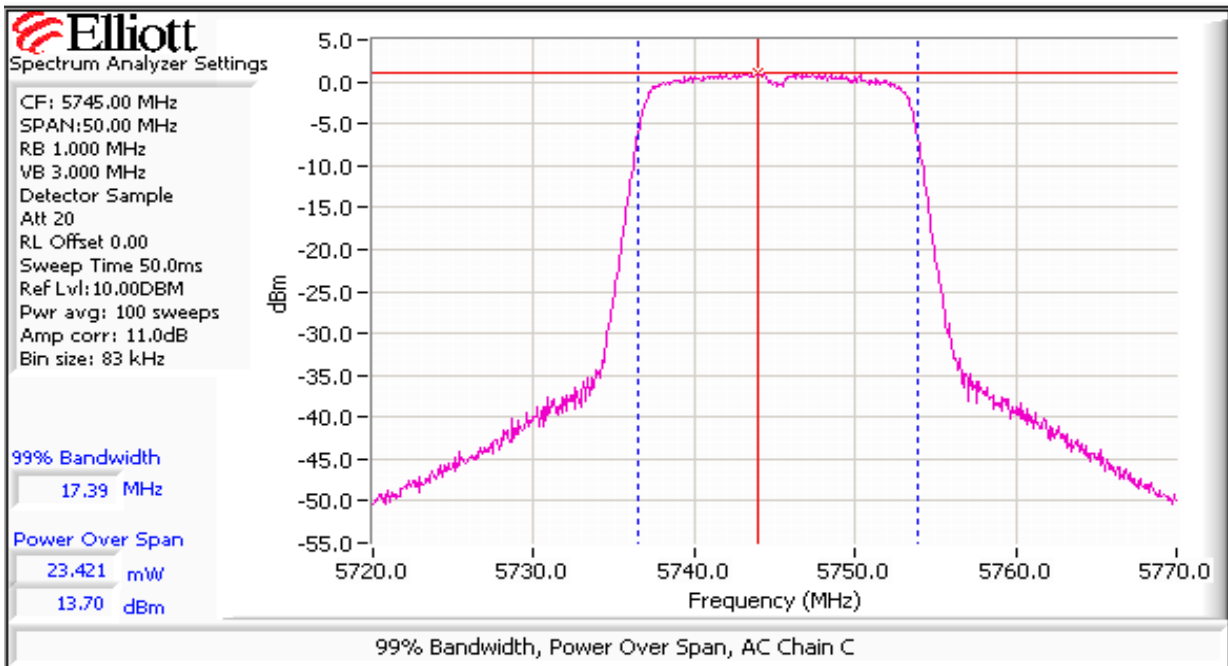
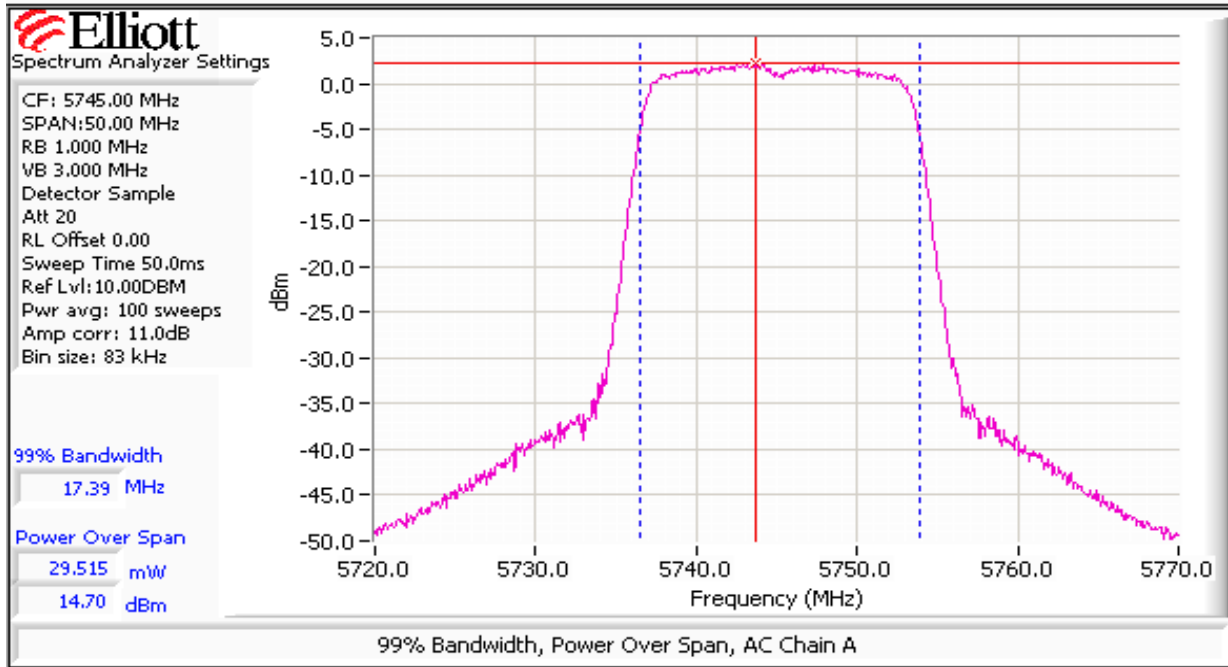

Client: Xirrus	Job Number: J71456
Model: XN-16 and XN-8	T-Log Number: T71643
Contact: Steve Smith	Account Manager: Susan Pezli
Standard: -	Class: N/A

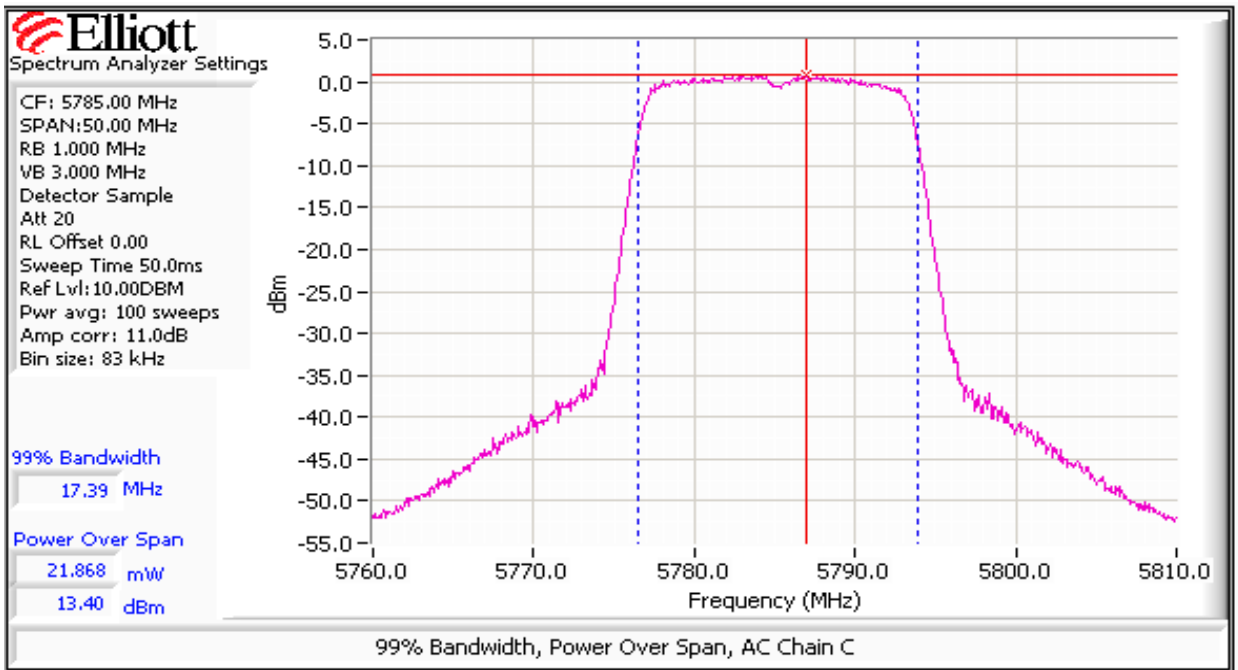
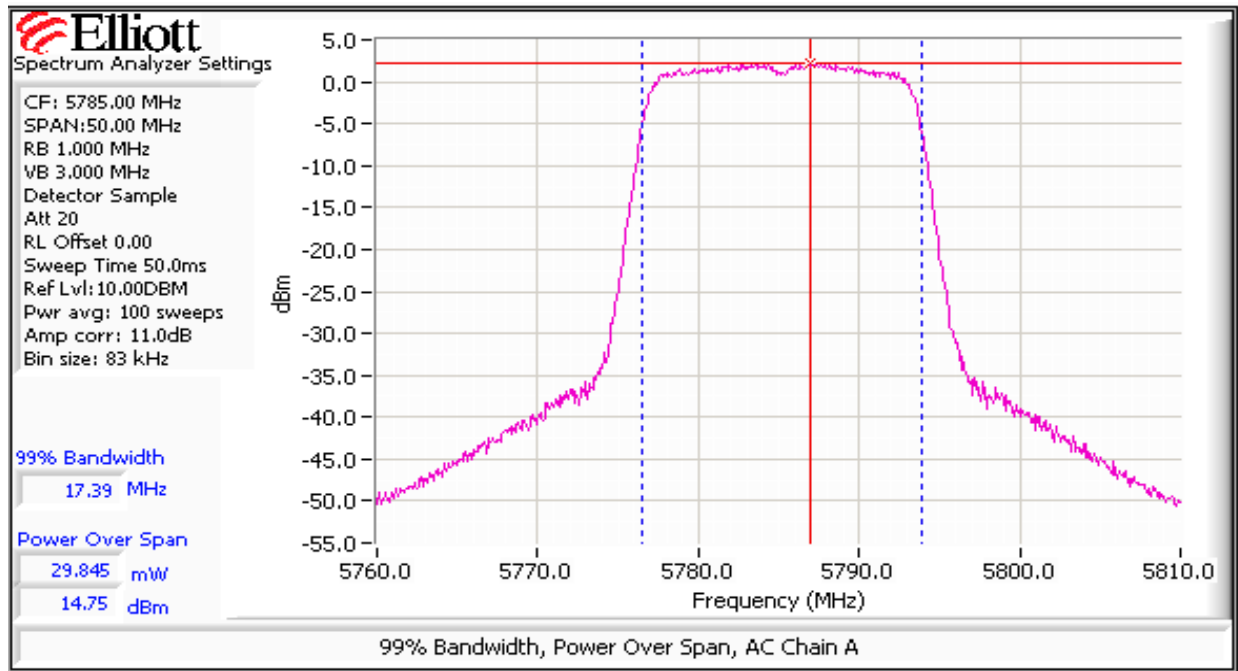

Client: Xirrus	Job Number: J71456
Model: XN-16 and XN-8	T-Log Number: T71643
Contact: Steve Smith	Account Manager: Susan Pezli
Standard: -	Class: N/A

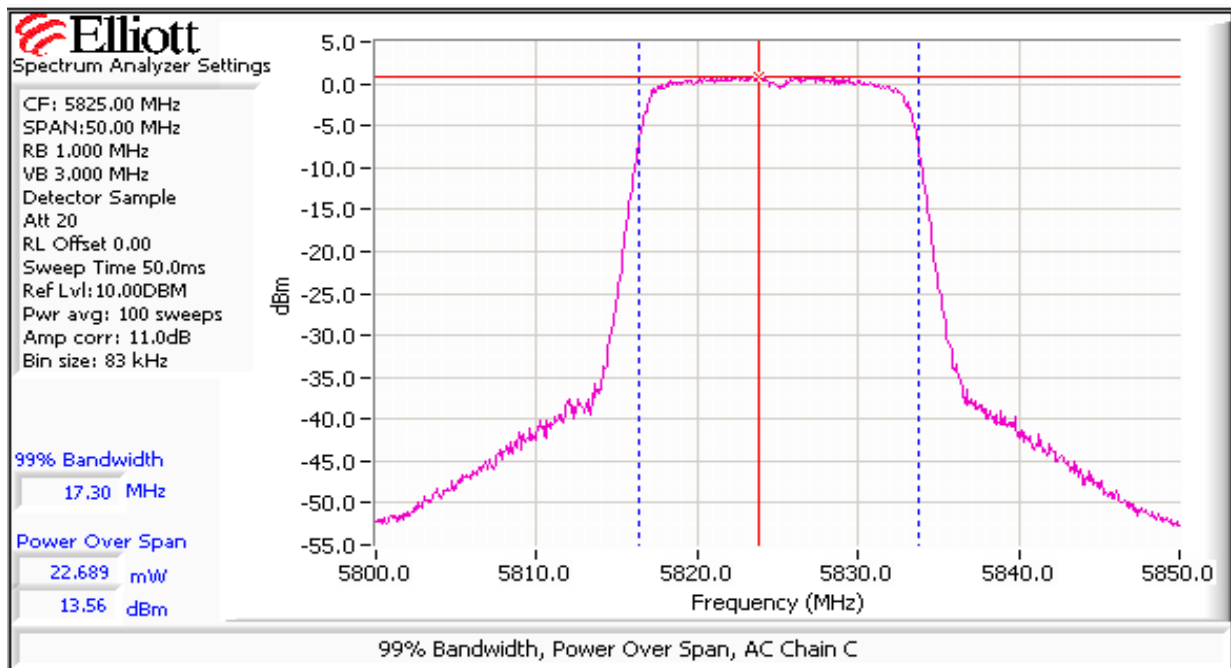
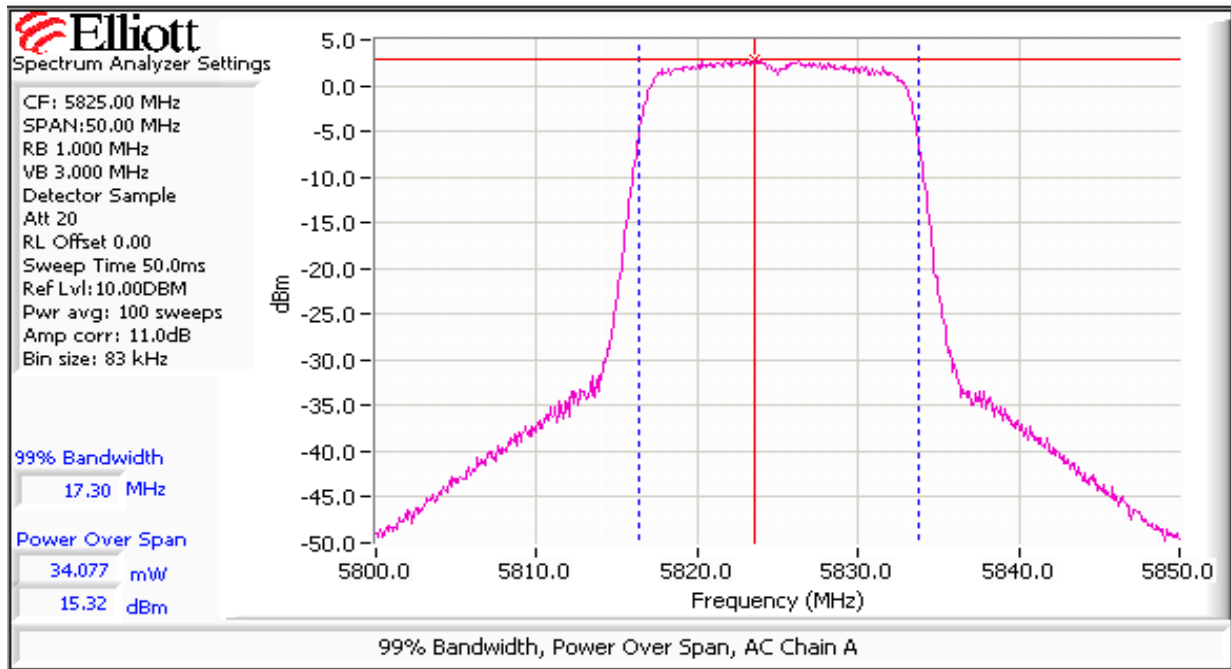

Client: Xirrus	Job Number: J71456
Model: XN-16 and XN-8	T-Log Number: T71643
Contact: Steve Smith	Account Manager: Susan Pezli
Standard: -	Class: N/A

Run #2: Power spectral Density

Power Setting	Frequency (MHz)	PSD (dBm/3kHz) ^{Note 1}				Total	Limit dBm/3kHz	Result
		Chain 1	Chain 2	Chain 3	Chain 4			
17.0	5745	-11.5		-10.5		-8.0	8.0	Pass
17.0	5785	-9.8		-10.5		-7.1	8.0	Pass
17.0	5825	-9.3		-10.8		-7.0	8.0	Pass

- Note 1: Power spectral density measured using RB=3 kHz, VB=10kHz, analyzer with peak detector and with a sweep time set to ensure a dwell time of at least 1 second per 3kHz. The measurement is made at the frequency of PPSD determined from preliminary scans using RB=3kHz using multiple sweeps at a faster rate over the 6dB bandwidth of the signal.
- Note 2: The operation of multiple radios in the band does not affect power spectral density as radios cannot operate on overlapping channels.

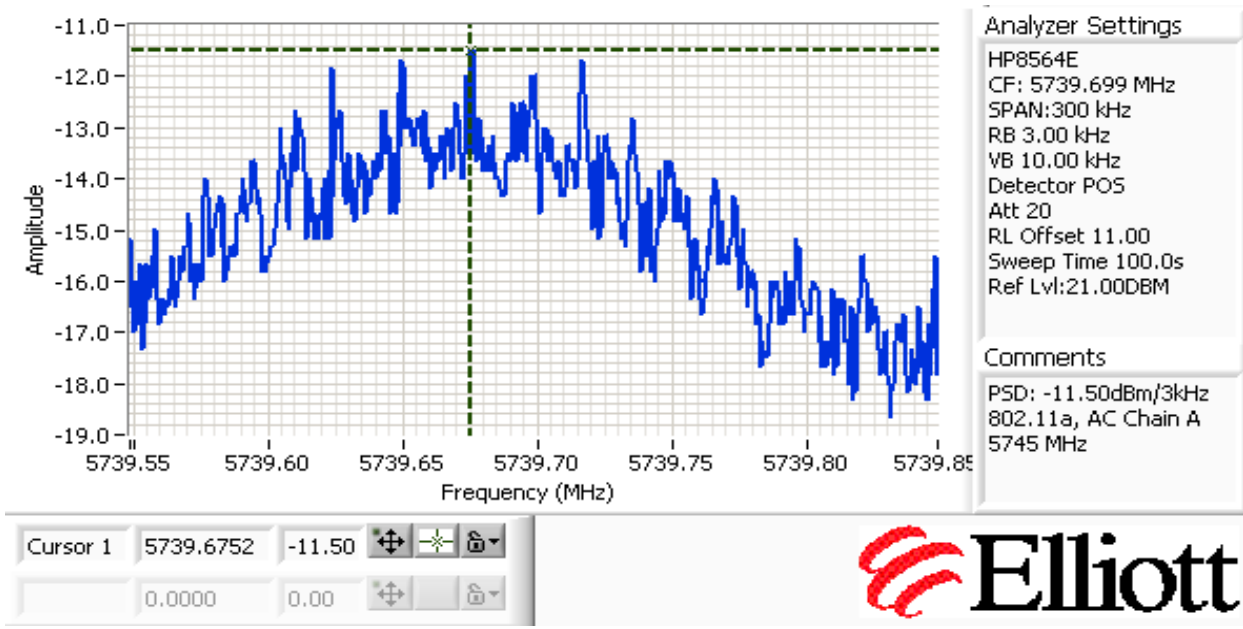

Client: Xirrus	Job Number: J71456
Model: XN-16 and XN-8	T-Log Number: T71643
Contact: Steve Smith	Account Manager: Susan Pezli
Standard: -	Class: N/A

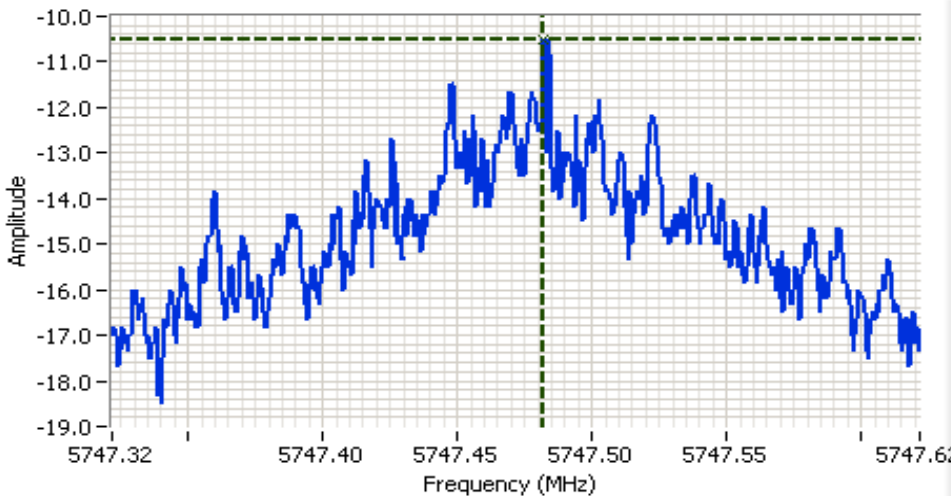

Analyzer Settings

HP8564E
 CF: 5747.472 MHz
 SPAN:300 kHz
 RB 3.00 kHz
 VB 10.00 kHz
 Detector POS
 Att 20
 RL Offset 11.00
 Sweep Time 100.0s
 Ref Lvl:21.00DBM

Comments

PSD: -10.50dBm/3kHz
 802.11a, AC Chain C
 5745 MHz

Cursor 1 5747.4822 -10.50

0.0000 0.00

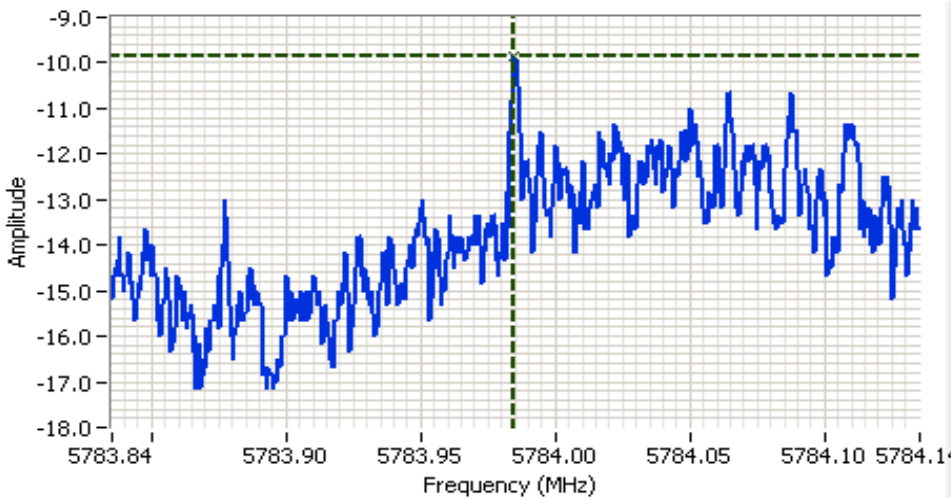

Analyzer Settings

HP8564E
 CF: 5783.985 MHz
 SPAN:300 kHz
 RB 3.00 kHz
 VB 10.00 kHz
 Detector POS
 Att 20
 RL Offset 11.00
 Sweep Time 100.0s
 Ref Lvl:21.00DBM

Comments

PSD: -9.83dBm/3kHz
 802.11a, AC Chain A
 5785 MHz

Cursor 1 5783.9849 -9.83

0.0000 0.00



Client: Xirrus	Job Number: J71456
Model: XN-16 and XN-8	T-Log Number: T71643
Contact: Steve Smith	Account Manager: Susan Pezli
Standard: -	Class: N/A

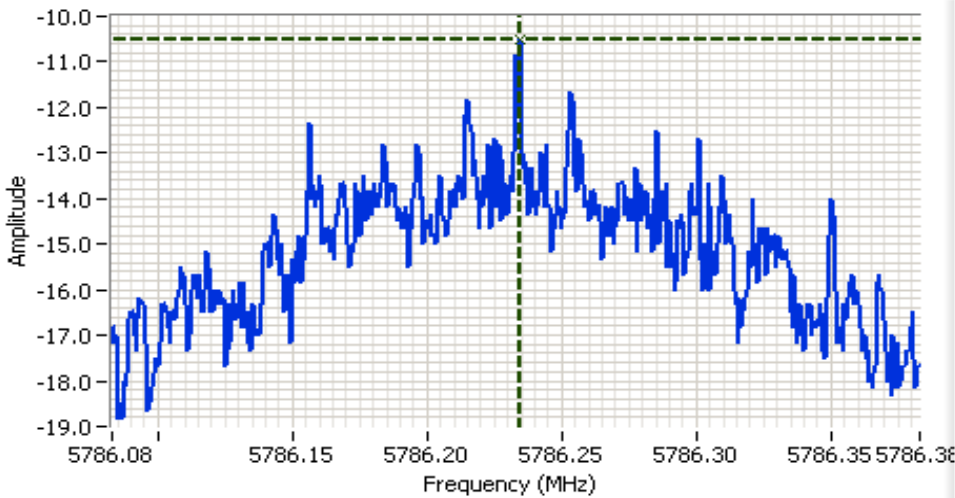

Analyzer Settings

HP8564E
 CF: 5786.233 MHz
 SPAN:300 kHz
 RB 3.00 kHz
 VB 10.00 kHz
 Detector POS
 Att 20
 RL Offset 11.00
 Sweep Time 100.0s
 Ref Lvl:21.00DBM

Comments

PSD: -10.50dBm/3kHz
 802.11a, AC Chain C
 5785 MHz

Cursor 1 5786.2344 -10.50

0.0000 0.00

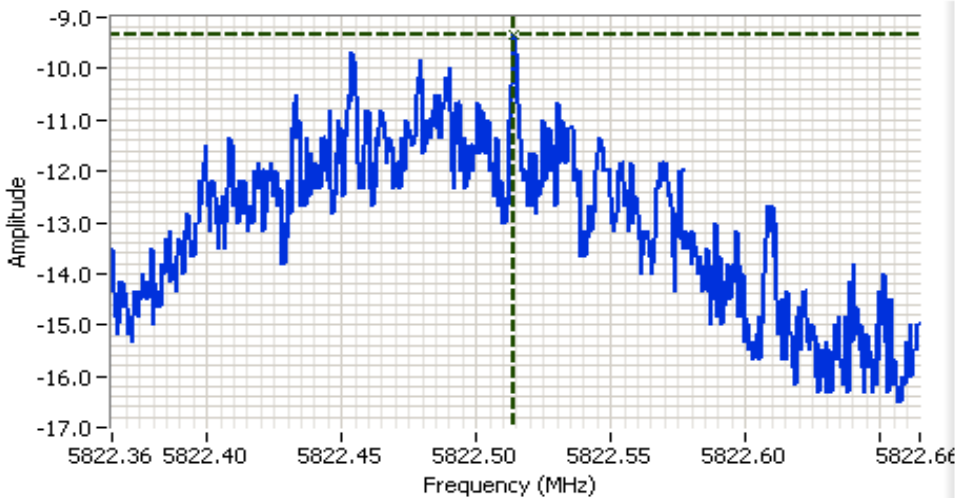

Analyzer Settings

HP8564E
 CF: 5822.515 MHz
 SPAN:300 kHz
 RB 3.00 kHz
 VB 10.00 kHz
 Detector POS
 Att 20
 RL Offset 11.00
 Sweep Time 100.0s
 Ref Lvl:21.00DBM

Comments

PSD: -9.33dBm/3kHz
 802.11a, AC Chain A
 5825 MHz

Cursor 1 5822.5141 -9.33

0.0000 0.00



Client: Xirrus	Job Number: J71456
Model: XN-16 and XN-8	T-Log Number: T71643
Contact: Steve Smith	Account Manager: Susan Pezli
Standard: -	Class: N/A

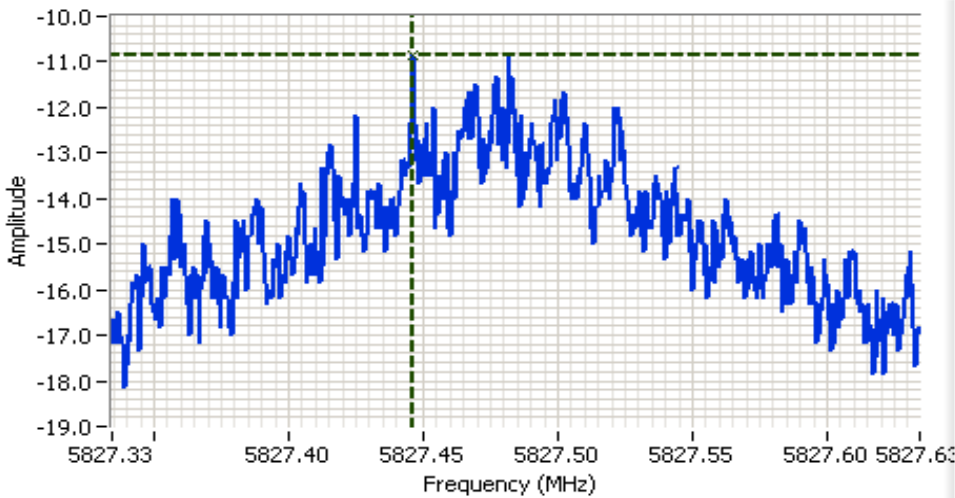

Analyzer Settings

HP8564E
 CF: 5827.484 MHz
 SPAN: 300 kHz
 RB 3.00 kHz
 VB 10.00 kHz
 Detector POS
 Att 20
 RL Offset 11.00
 Sweep Time 100.0s
 Ref Lvl: 21.00DBM

Comments

PSD: -10.83dBm/3kHz
 802.11a, AC Chain C
 5825 MHz

Cursor 1	5827.4464	-10.83	
	0.0000	0.00	



Client: Xirrus	Job Number: J71456
Model: XN-16 and XN-8	T-Log Number: T71643
	Account Manager: Susan Pezli
Contact: Steve Smith	
Standard: -	Class: N/A

Run #3: Signal Bandwidth

Mode	Power Setting	Frequency (MHz)	Resolution Bandwidth	Chain A		Chain C	
				Bandwidth (MHz) 6dB	Bandwidth (MHz) 99%	Bandwidth (MHz) 6dB	Bandwidth (MHz) 99%
802.11a	17	5745	100k	16.6	17.4	16.6	17.4
802.11a	17	5785	100k	16.3	17.4	16.5	17.4
802.11a	17	5825	100k	16.4	17.3	16.4	17.3

Note 1: Measured on each chain

Note 2: 99% bandwidth measured in accordance with RSS GEN, with RB > 1% of the span and VB > 3xRB

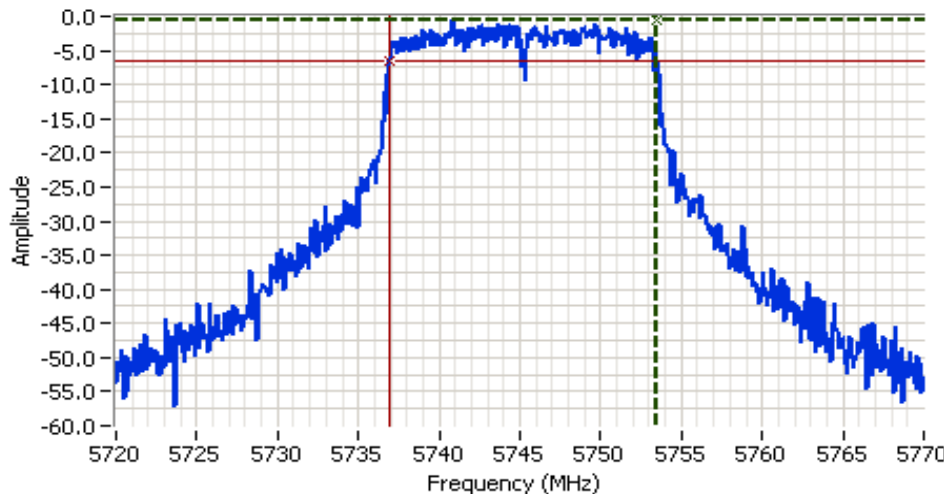

Analyzer Settings

HP8564E
 CF: 5745.000 MHz
 SPAN: 50.000 MHz
 RB 100 kHz
 VB 100 kHz
 Detector POS
 Att 20
 RL Offset 11.00
 Sweep Time 50.0ms
 Ref Lvl: 21.00DBM

Comments

6dB BW: 16.583 MHz
 802.11a, AC Chain A

Cursor 1	5753.5000	-0.67	
Cursor 2	5736.9167	-6.67	

Delta Freq. 16.583
 Delta Amplitude 6.00



Client: Xirrus	Job Number: J71456
Model: XN-16 and XN-8	T-Log Number: T71643
Contact: Steve Smith	Account Manager: Susan Pezli
Standard: -	Class: N/A

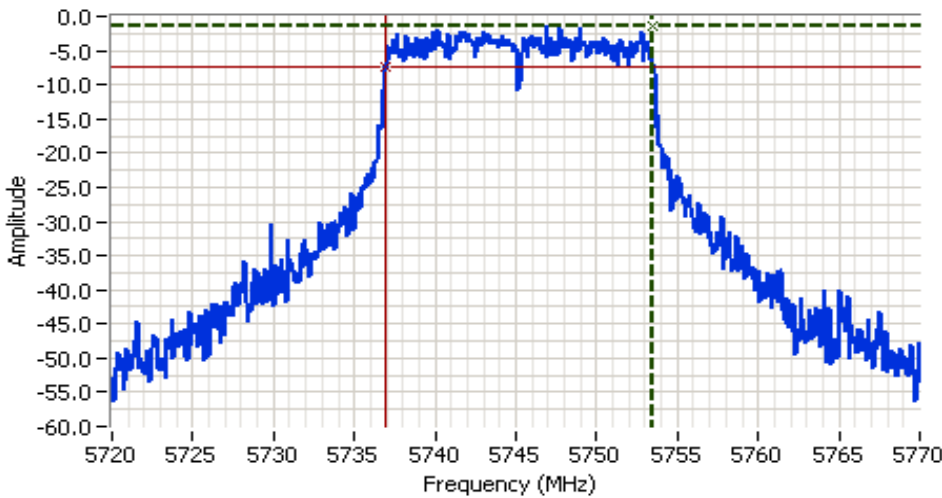

Analyzer Settings

HP8564E
 CF: 5745.000 MHz
 SPAN:50.000 MHz
 RB 100 kHz
 VB 100 kHz
 Detector POS
 Att 20
 RL Offset 11.00
 Sweep Time 50.0ms
 Ref Lvl:21.00DBM

Comments

6dB BW: 16.583 MHz
 802.11a, AC Chain C

Cursor 1 5753.5000 -1.50

Cursor 2 5736.9167 -7.50

Delta Freq. 16.583

Delta Amplitude 6.00

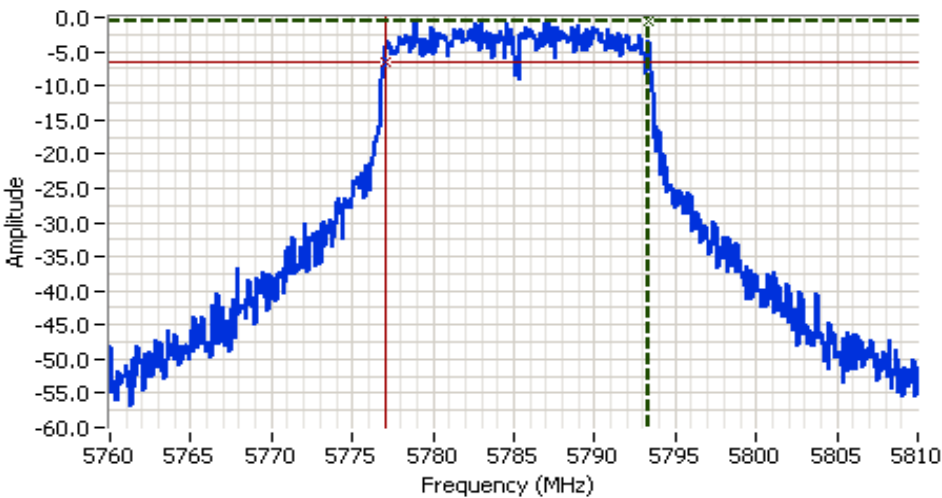

Analyzer Settings

HP8564E
 CF: 5785.000 MHz
 SPAN:50.000 MHz
 RB 100 kHz
 VB 100 kHz
 Detector POS
 Att 20
 RL Offset 11.00
 Sweep Time 50.0ms
 Ref Lvl:21.00DBM

Comments

6dB BW: 16.333 MHz
 802.11a, AC Chain A

Cursor 1 5793.3333 -0.50

Cursor 2 5777.0000 -6.50

Delta Freq. 16.333

Delta Amplitude 6.00



Client: Xirrus	Job Number: J71456
Model: XN-16 and XN-8	T-Log Number: T71643
Contact: Steve Smith	Account Manager: Susan Pezli
Standard: -	Class: N/A

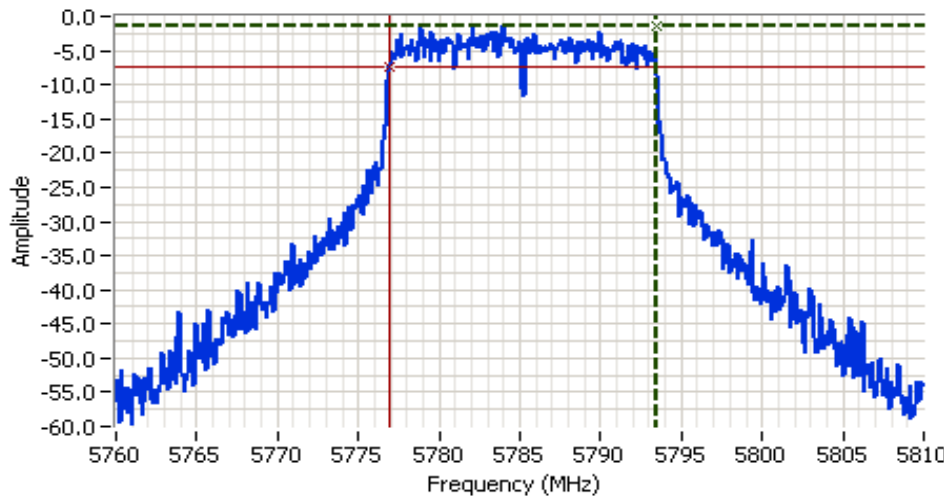

Analyzer Settings

HP8564E
 CF: 5785.000 MHz
 SPAN:50.000 MHz
 RB 100 kHz
 VB 100 kHz
 Detector POS
 Att 20
 RL Offset 11.00
 Sweep Time 50.0ms
 Ref Lvl:21.00DBM

Comments

6dB BW: 16.500 MHz
 802.11a, AC Chain C

Cursor 1 5793.4167 -1.50
 Cursor 2 5776.9167 -7.50

Delta Freq. 16.500
 Delta Amplitude 6.00

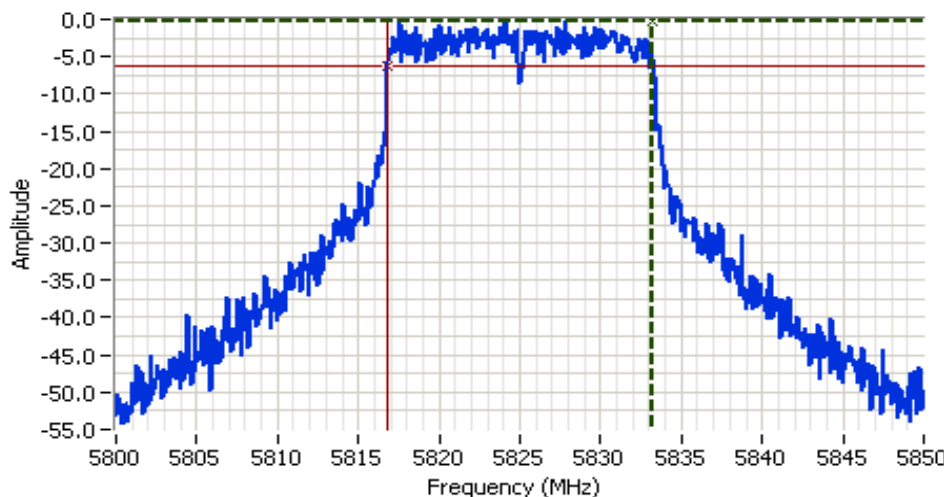

Analyzer Settings

HP8564E
 CF: 5825.000 MHz
 SPAN:50.000 MHz
 RB 100 kHz
 VB 100 kHz
 Detector POS
 Att 20
 RL Offset 11.00
 Sweep Time 50.0ms
 Ref Lvl:21.00DBM

Comments

6dB BW: 16.417 MHz
 802.11a, AC Chain A

Cursor 1 5833.2500 -0.17
 Cursor 2 5816.8333 -6.17

Delta Freq. 16.417
 Delta Amplitude 6.00



Client: Xirrus	Job Number: J71456
Model: XN-16 and XN-8	T-Log Number: T71643
	Account Manager: Susan Pezli
Contact: Steve Smith	
Standard: -	Class: N/A

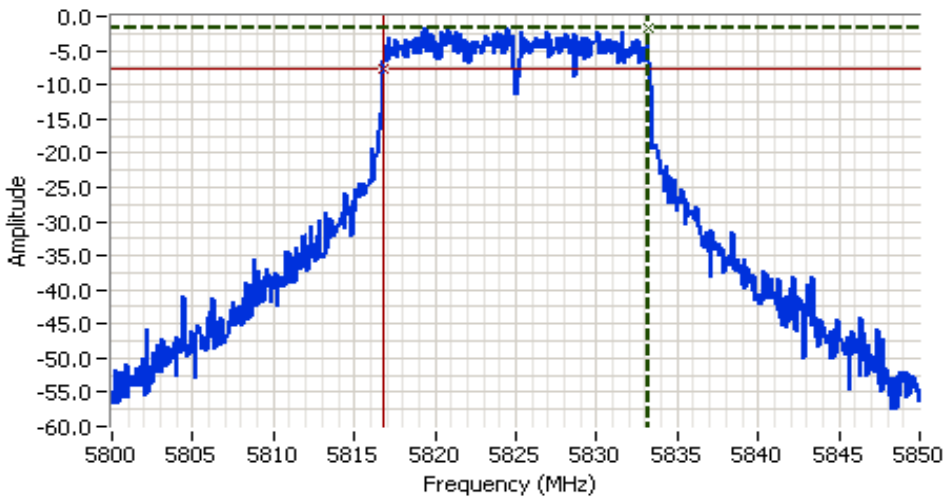

Analyzer Settings

HP8564E
 CF: 5825.000 MHz
 SPAN: 50.000 MHz
 RB 100 kHz
 VB 100 kHz
 Detector POS
 Att 20
 RL Offset 11.00
 Sweep Time 50.0ms
 Ref Lvl: 21.00DBM

Comments

6dB BW: 16.417 MHz
 802.11a, AC Chain C

Cursor 1	5833.2500	-1.67	
Cursor 2	5816.8333	-7.67	

Delta Freq.	16.417
Delta Amplitude	6.00



Client: Xirrus	Job Number: J71456
Model: XN-16 and XN-8	T-Log Number: T71643
	Account Manager: Susan Pezli
Contact: Steve Smith	
Standard: -	Class: N/A

Run #4: Out of Band Spurious Emissions

Measured using RBW>=100kHz, VBW>= RB

Frequency (MHz)	Limit	Result
5745	-30dBc	Pass
5785	-30dBc	Pass
5825	-30dBc	Pass

Plots for low channel - 802.11a - , power setting(s) = 17

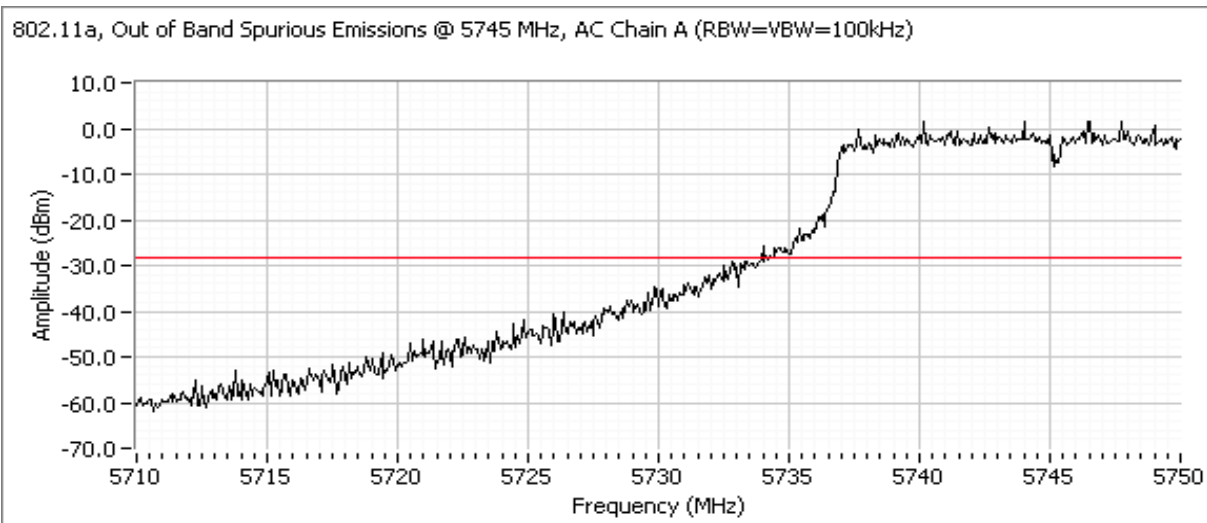
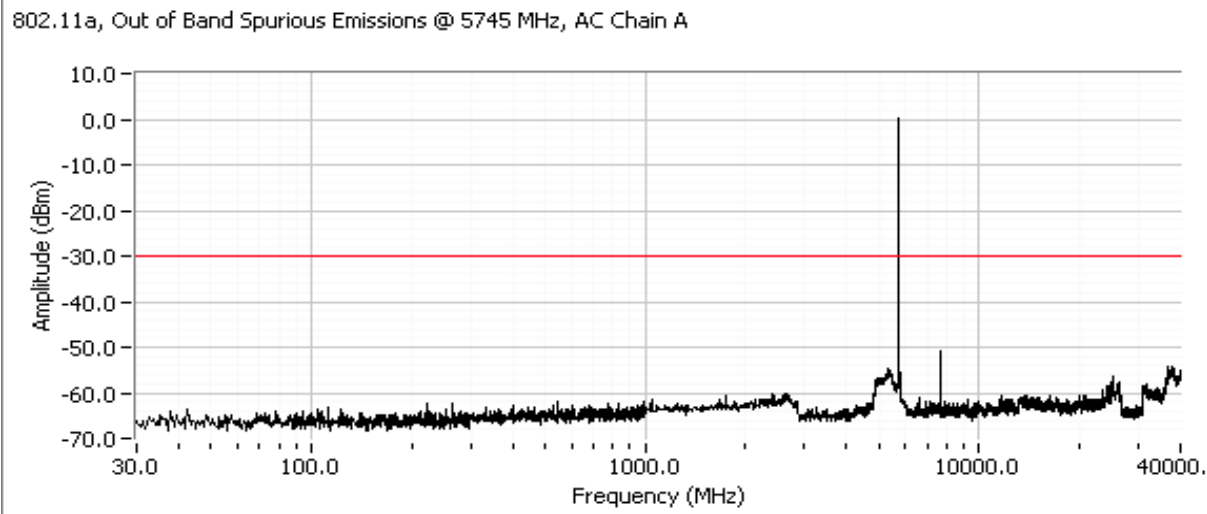

Client: Xirrus	Job Number: J71456
Model: XN-16 and XN-8	T-Log Number: T71643
	Account Manager: Susan Pezli
Contact: Steve Smith	
Standard: -	Class: N/A

Plots for low channel - 802.11a - , power setting(s) = 17

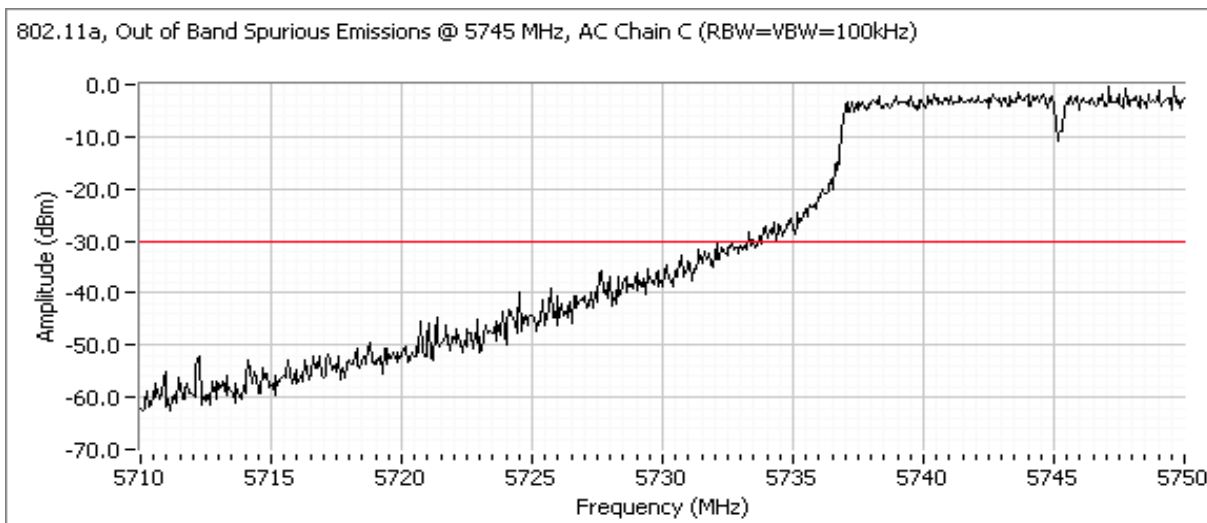
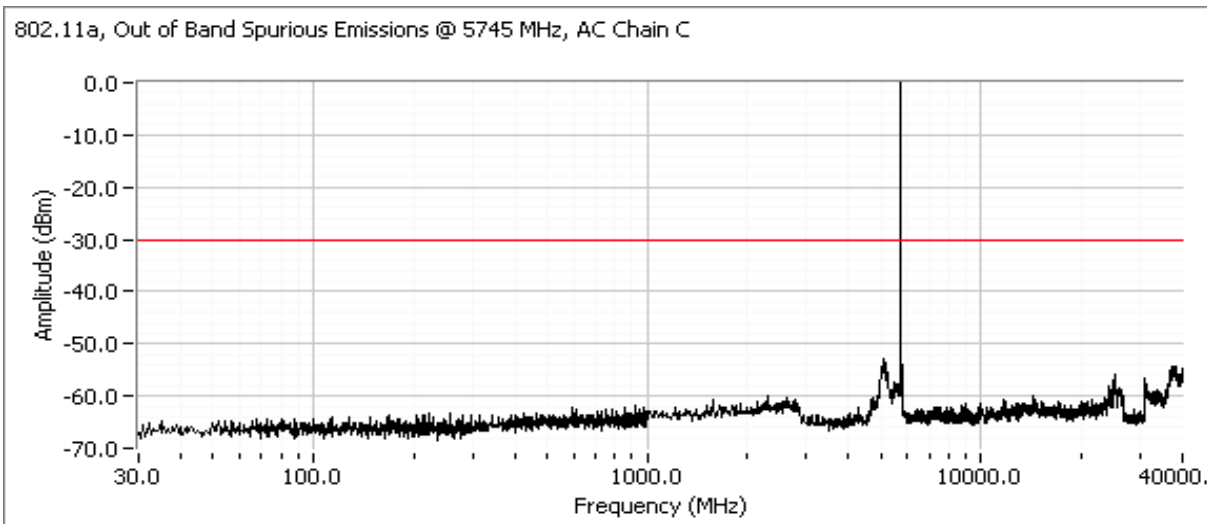

Client: Xirrus	Job Number: J71456
Model: XN-16 and XN-8	T-Log Number: T71643
	Account Manager: Susan Pezli
Contact: Steve Smith	
Standard: -	Class: N/A

Plots for center channel - 802.11a - , power setting(s) = 17

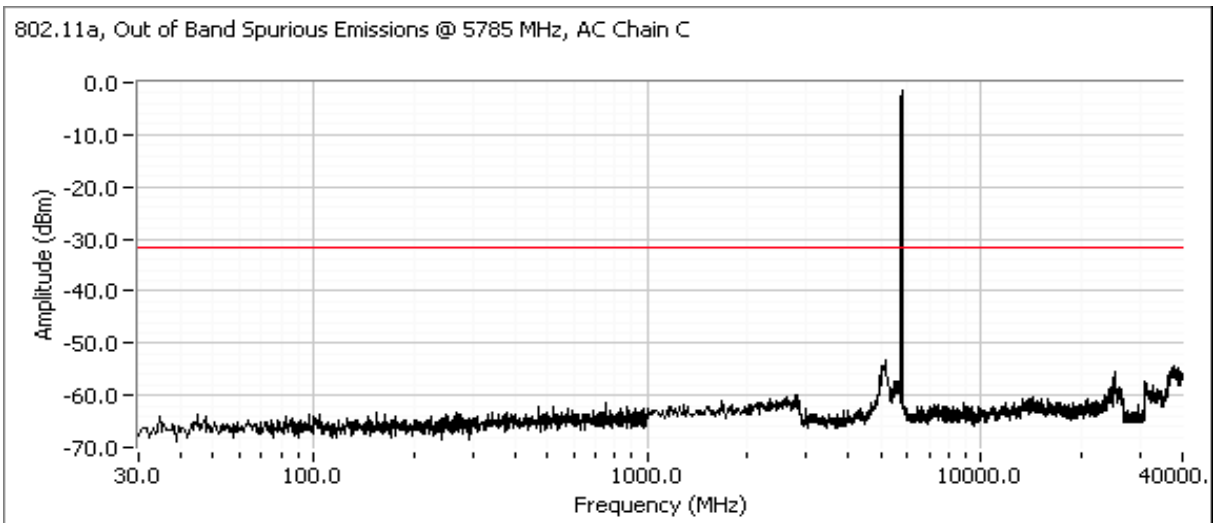
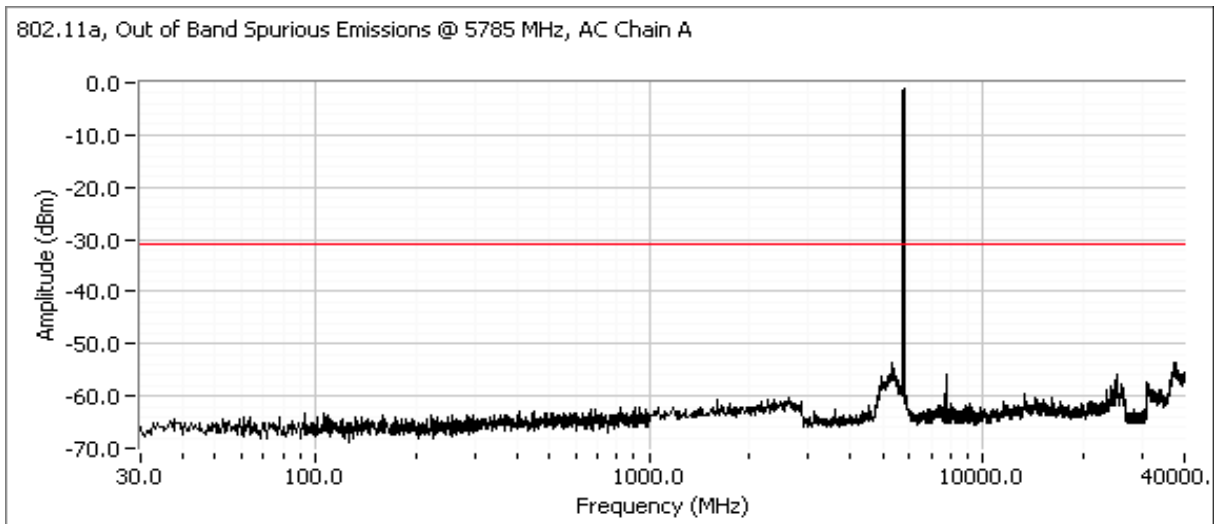

Client: Xirrus	Job Number: J71456
Model: XN-16 and XN-8	T-Log Number: T71643
	Account Manager: Susan Pezli
Contact: Steve Smith	
Standard: -	Class: N/A

Plots for high channel - 802.11a - , power setting(s) = 17

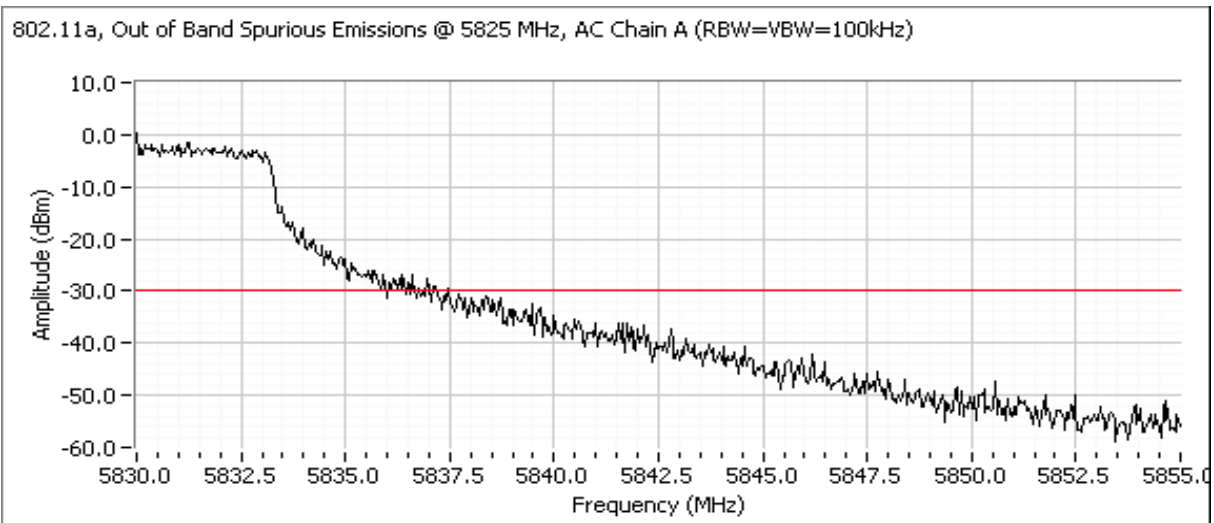
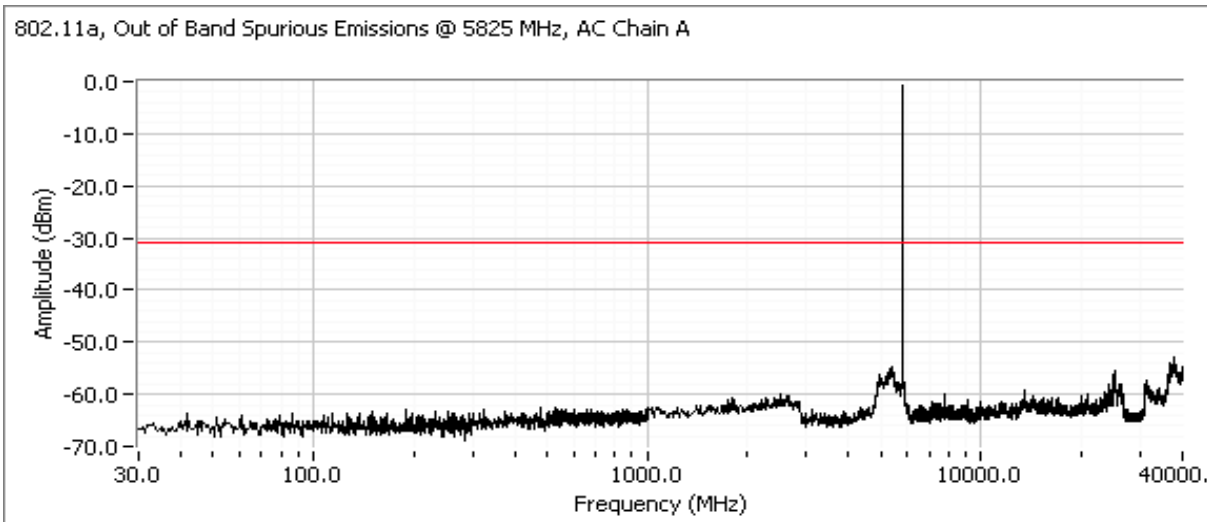

Client: Xirrus	Job Number: J71456
Model: XN-16 and XN-8	T-Log Number: T71643
	Account Manager: Susan Pezli
Contact: Steve Smith	
Standard: -	Class: N/A

Plots for high channel - 802.11a - , power setting(s) = 17

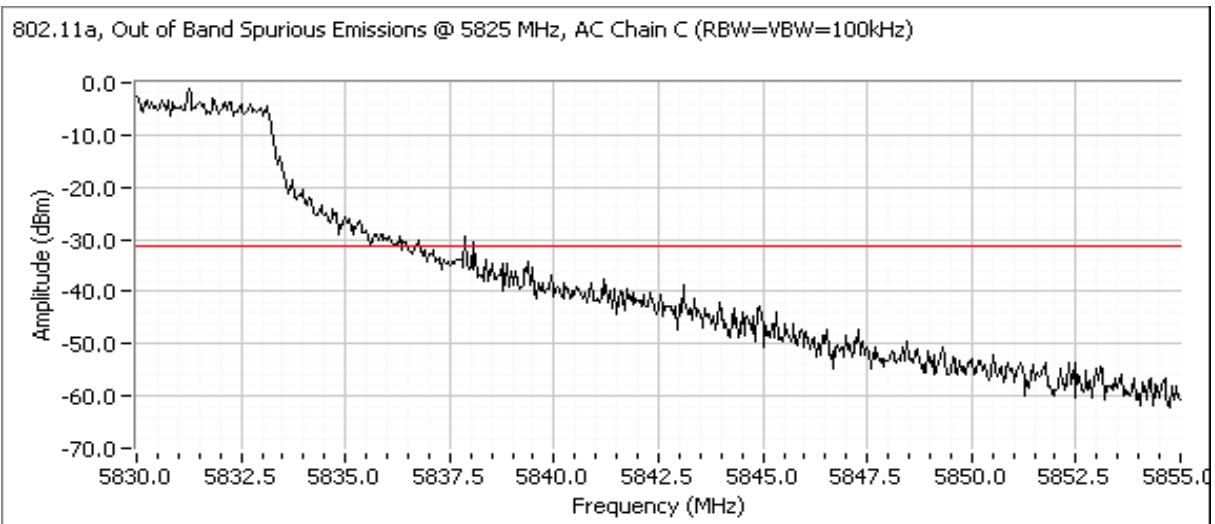
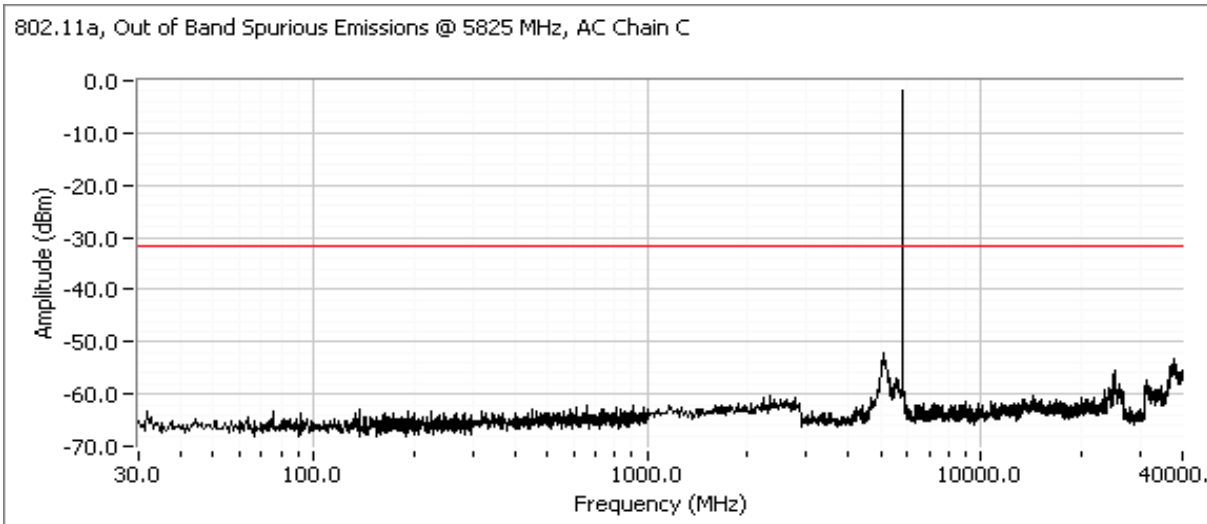

Client: Xirrus	Job Number: J71456
Model: XN-16 and XN-8	T-Log Number: T71643
	Account Manager: Susan Pelzi
Contact: Steve Smith	
Standard: -	Class: N/A

RSS 210 and FCC 15.247 (DTS) Antenna Port Measurements
MIMO and Smart Antenna Systems
Power, PSD, Bandwidth and Spurious Emissions

Test Specific Details

Objective: The objective of this test session is to perform final qualification testing of the EUT with respect to the specification listed above.

Date of Test: 6/9/2008	Config. Used: -
Test Engineer: Mehran Birgani	Config Change: -
Test Location: Chamber #2	EUT Voltage: POE

General Test Configuration

The EUT was connected to the spectrum analyzer or power meter via a suitable attenuator.

All measurements have been corrected to allow for the external attenuators used.

Ambient Conditions:	Temperature:	19 °C
	Rel. Humidity:	36 %

Summary of Results

Run #	Test Performed	Limit	Pass / Fail	Result / Margin
1	Output Power Chain A+C	15.247(b)	Pass	802.11n20: 17.4 dBm 802.11n40: 17.2 dBm
2	PSD Chain A+C	15.247(d)	Pass	n20: -1.8 dBm/3kHz n40: -9.8 dBm/3kHz
3	Minimum 6dB Bandwidth	15.247(a)	Pass	802.11n20: 17.7 MHz 802.11n40: 36.4 MHz
3	99% Bandwidth	RSS GEN	Pass	802.11n20: 18.6 MHz 802.11n40: 37.0 MHz
4	Spurious emissions	15.247(b)	Pass	All signal were more than 30dB below the fundamental

Modifications Made During Testing

No modifications were made to the EUT during testing

Deviations From The Standard

No deviations were made from the requirements of the standard.



EMC Test Data

Client: Xirrus	Job Number: J71456
Model: XN-16 and XN-8	T-Log Number: T71643
Contact: Steve Smith	Account Manager: Susan Pezli
Standard: -	Class: N/A

Run #1: Output Power - Chain A + C

Transmitted signal on chain is coherent? No

Single radio Operating in the Band

5745 802.11n 20MHz	Chain 1	Chain 2	Chain 3	Chain 4	Total Across All Chains		Limit	
Power Setting ^{Note 3}	17.0		17.0		Total Across All Chains		Limit	
Output Power (dBm) ^{Note 1}	14.7		13.7		17.3 dBm	0.053 W	30.0 dBm	1.000 W
Antenna Gain (dBi) ^{Note 2}	6.0		6.0		6.0 dBi		Pass	
eirp (dBm) ^{Note 2}	20.7		19.7		23.3 dBm	0.212 W		
5785 802.11n 20MHz	Chain 1	Chain 2	Chain 3	Chain 4	Total Across All Chains		Limit	
Power Setting ^{Note 3}	17.0		17.0		Total Across All Chains		Limit	
Output Power (dBm) ^{Note 1}	14.6		13.5		17.1 dBm	0.051 W	30.0 dBm	1.000 W
Antenna Gain (dBi) ^{Note 2}	6.0		6.0		6.0 dBi		Pass	
eirp (dBm) ^{Note 2}	20.6		19.5		23.1 dBm	0.203 W		
5825 802.11n 20MHz	Chain 1	Chain 2	Chain 3	Chain 4	Total Across All Chains		Limit	
Power Setting ^{Note 3}	17.0		17.0		Total Across All Chains		Limit	
Output Power (dBm) ^{Note 1}	15.0		13.6		17.4 dBm	0.055 W	30.0 dBm	1.000 W
Antenna Gain (dBi) ^{Note 2}	6.0		6.0		6.0 dBi		Pass	
eirp (dBm) ^{Note 2}	21.0		19.6		23.4 dBm	0.217 W		
5755 802.11n 40MHz	Chain 1	Chain 2	Chain 3	Chain 4	Total Across All Chains		Limit	
Power Setting ^{Note 3}	17.0		17.0		Total Across All Chains		Limit	
Output Power (dBm) ^{Note 1}	14.5		13.8		17.2 dBm	0.052 W	30.0 dBm	1.000 W
Antenna Gain (dBi) ^{Note 2}	6.0		6.0		6.0 dBi		Pass	
eirp (dBm) ^{Note 2}	20.5		19.8		23.2 dBm	0.207 W		
5795 802.11n 40MHz	Chain 1	Chain 2	Chain 3	Chain 4	Total Across All Chains		Limit	
Power Setting ^{Note 3}	17.0		17.0		Total Across All Chains		Limit	
Output Power (dBm) ^{Note 1}	11.8		13.5		15.8 dBm	0.038 W	30.0 dBm	1.000 W
Antenna Gain (dBi) ^{Note 2}	6.0		6.0		6.0 dBi		Pass	
eirp (dBm) ^{Note 2}	17.8		19.5		21.8 dBm	0.150 W		

Client: Xirrus	Job Number: J71456
Model: XN-16 and XN-8	T-Log Number: T71643
	Account Manager: Susan Pezli
Contact: Steve Smith	
Standard: -	Class: N/A

Five radios on non-overlapping channels, note 3

802.11n 20MHz	Chain 1	Chain 2	Chain 3	Chain 4	Total Across All Chains		Limit	
Power Setting ^{Note 3}	17.0		17.0					
Output Power (dBm) ^{Note 1}	15.0		13.6		24.4 dBm	0.273 W	30.0 dBm	1.000 W
Antenna Gain (dBi) ^{Note 2}	6.0		6.0			-1.0 dBi	Pass	
eirp (dBm) ^{Note 2}	21.0		19.6		23.4 dBm	0.217 W		

Two radios on 40 MHz non-overlapping channels, note 3

802.11n 40MHz	Chain 1	Chain 2	Chain 3	Chain 4	Total Across All Chains		Limit	
Power Setting ^{Note 3}	17.0		17.0					
Output Power (dBm) ^{Note 1}	11.8		13.5		18.8 dBm	0.075 W	30.0 dBm	1.000 W
Antenna Gain (dBi) ^{Note 2}	6.0		6.0			3.0 dBi	Pass	
eirp (dBm) ^{Note 2}	17.8		19.5		21.8 dBm	0.150 W		

Note 1:	Output power measured using a spectrum analyzer (see plots below) with RBW=1MHz, VB=3 MHz, sample detector, power averaging on (transmitted signal was continuous) and power integration over 50 MHz for 802.11n 20MHz mode and 80 MHz for 802.11n 40MHz mode (reference method 1 of FCC DA 02-2138 for U-NII devices, August 30, 2002). Spurious limit becomes -30dBc.
Note 2:	As there is no coherency between chains the total EIRP is the sum of the individual EIRPs and effective antenna gain equals the eirp divide by the sum of the power on each chain.
Note 3:	The device has multiple radios, but the software limits operation in any band to ensure only non-overlapping channels are used (no two radios can operate on the same channel or on overlapping channels). In the 5745 - 5785 MHz band there can be a maximum of 5 radios active (5, non-overlapping 20MHz channels) or 2 40 Mhz channels. The calculated total power (obtained by multiplying the output power on a single radio by the number of radios that can be operating in the band) demonstrates that, with 5 (or 2 for n40 mode) radios active, the total output power still complies with the limit.

Client: Xirus	Job Number: J71456
Model: XN-16 and XN-8	T-Log Number: T71643
Contact: Steve Smith	Account Manager: Susan Pezli
Standard: -	Class: N/A

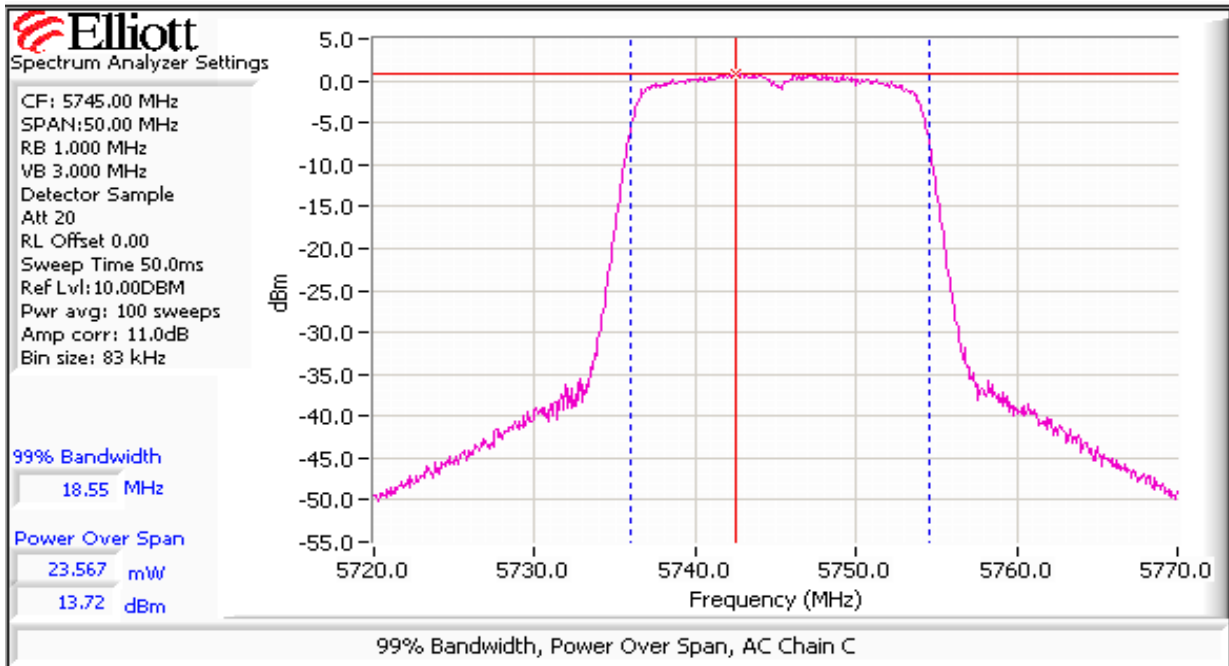
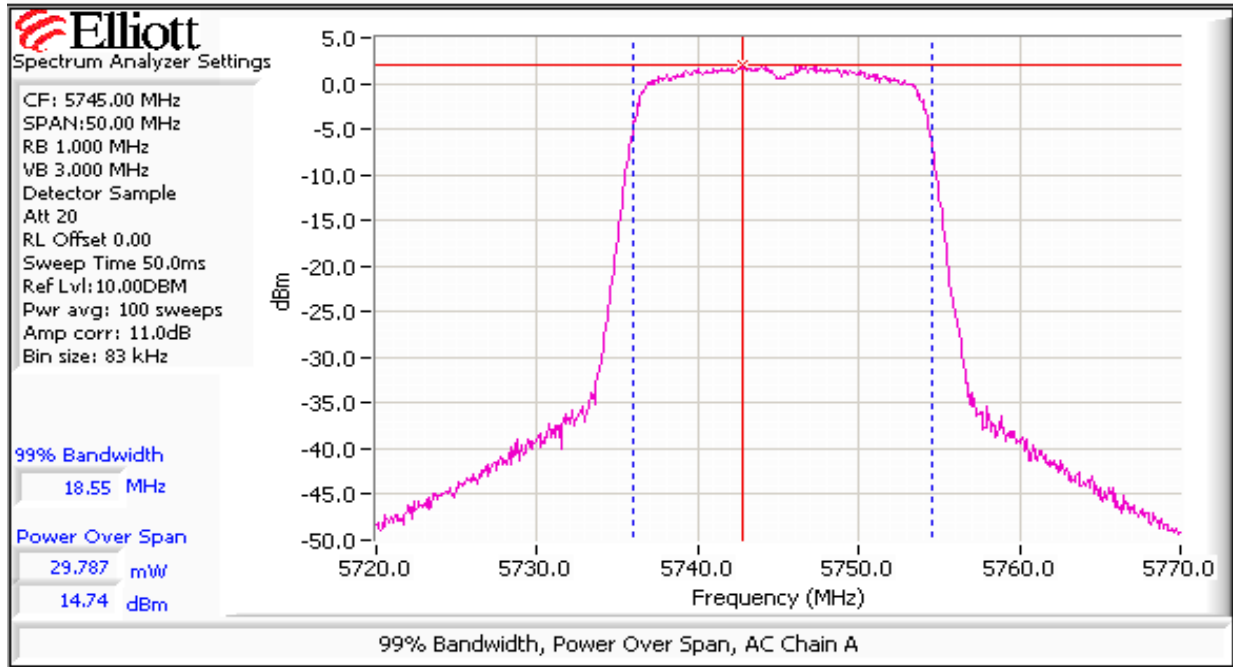

Client: Xirrus	Job Number: J71456
Model: XN-16 and XN-8	T-Log Number: T71643
	Account Manager: Susan Pezli
Contact: Steve Smith	
Standard: -	Class: N/A

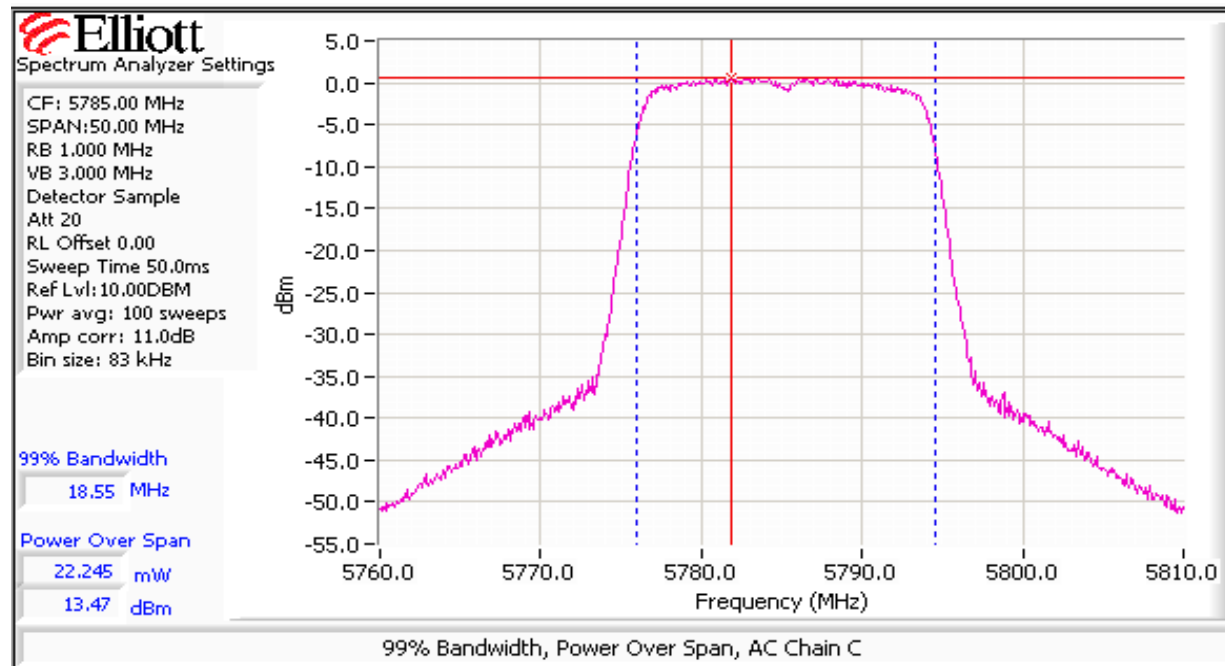
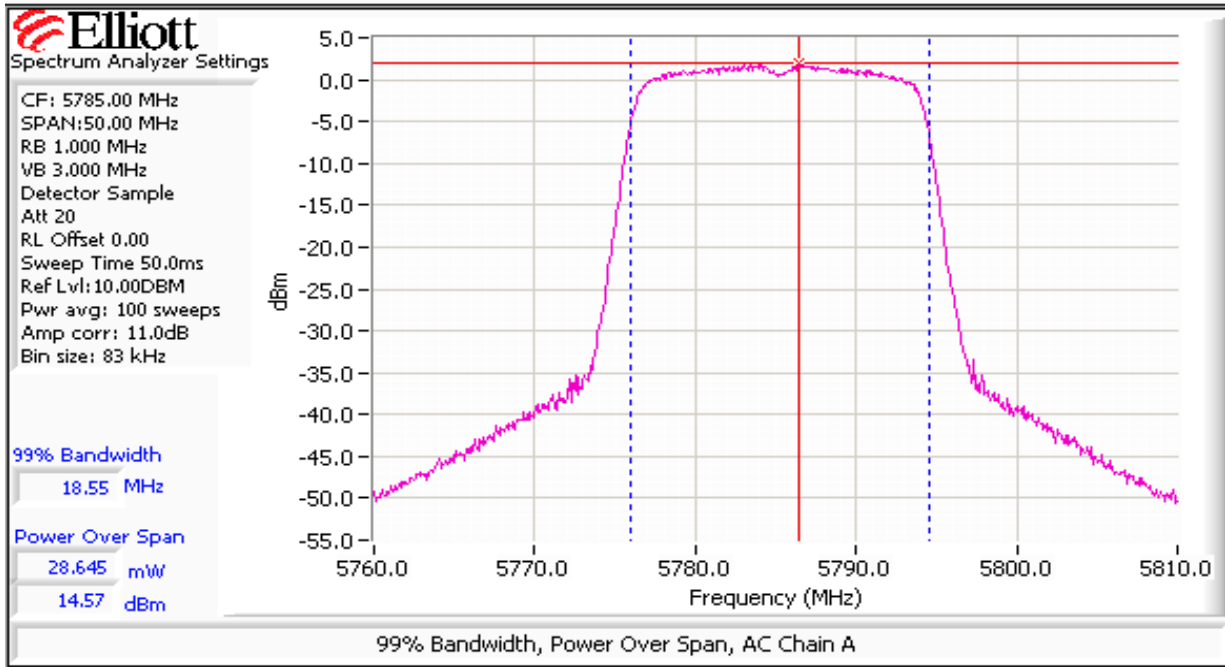

Client: Xirrus	Job Number: J71456
Model: XN-16 and XN-8	T-Log Number: T71643
Contact: Steve Smith	Account Manager: Susan Pezli
Standard: -	Class: N/A

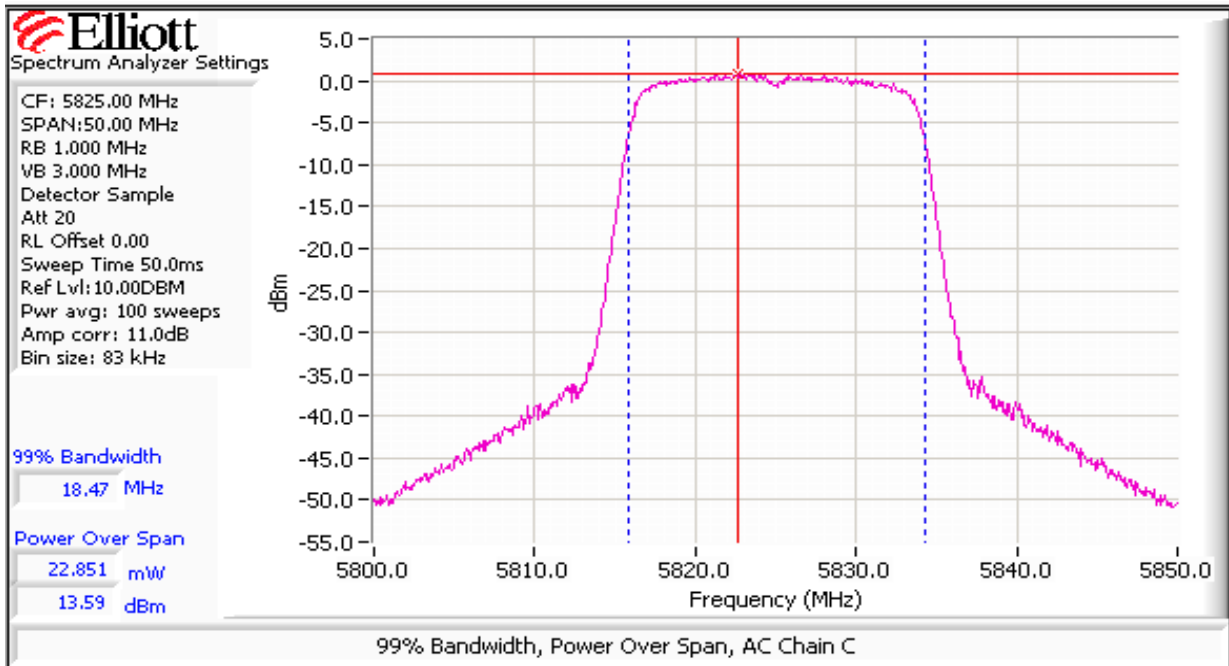
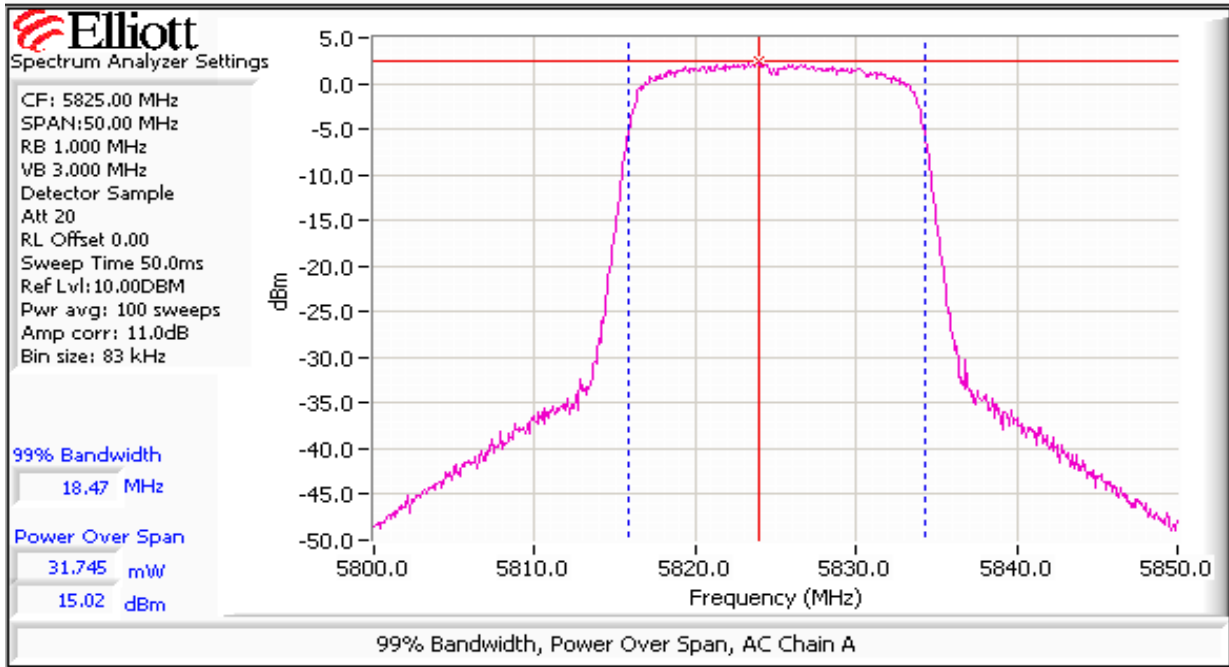

Client: Xirrus	Job Number: J71456
Model: XN-16 and XN-8	T-Log Number: T71643
Contact: Steve Smith	Account Manager: Susan Pezli
Standard: -	Class: N/A

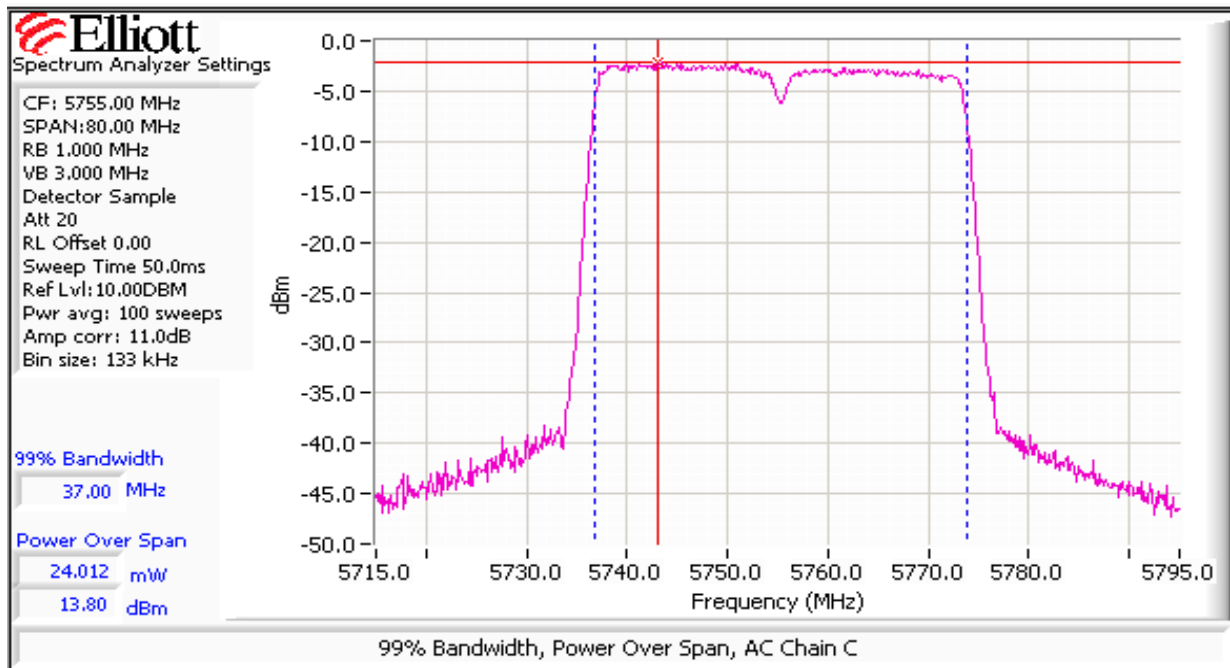
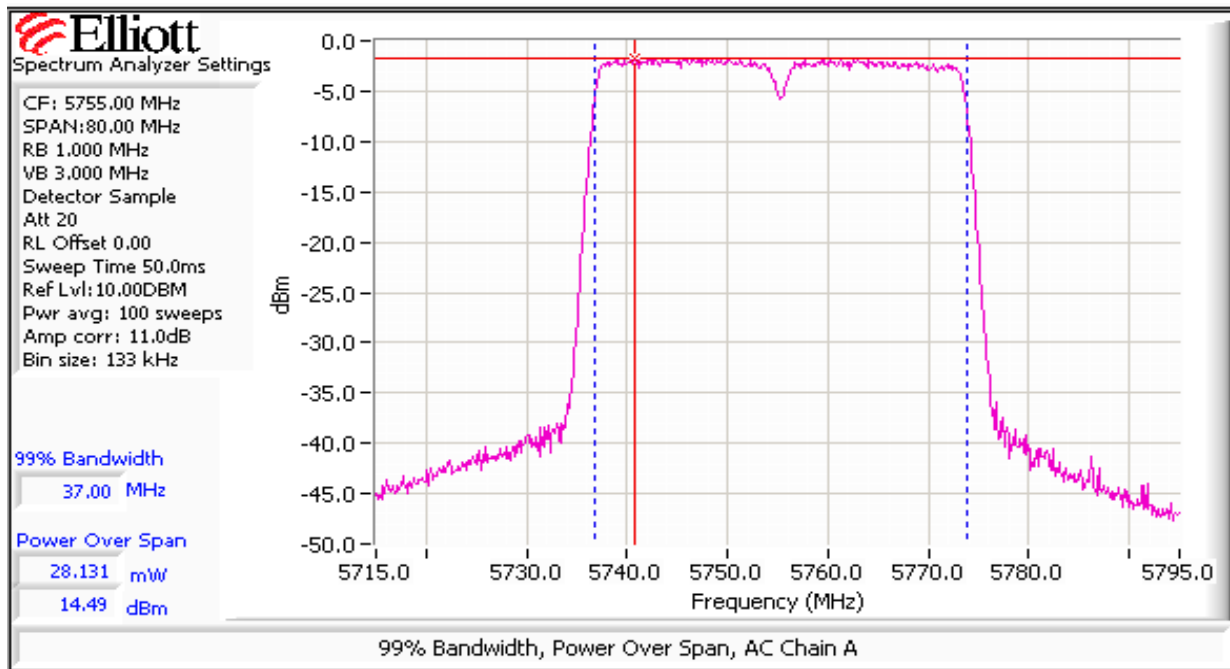

Client: Xirrus	Job Number: J71456
Model: XN-16 and XN-8	T-Log Number: T71643
Contact: Steve Smith	Account Manager: Susan Pezli
Standard: -	Class: N/A

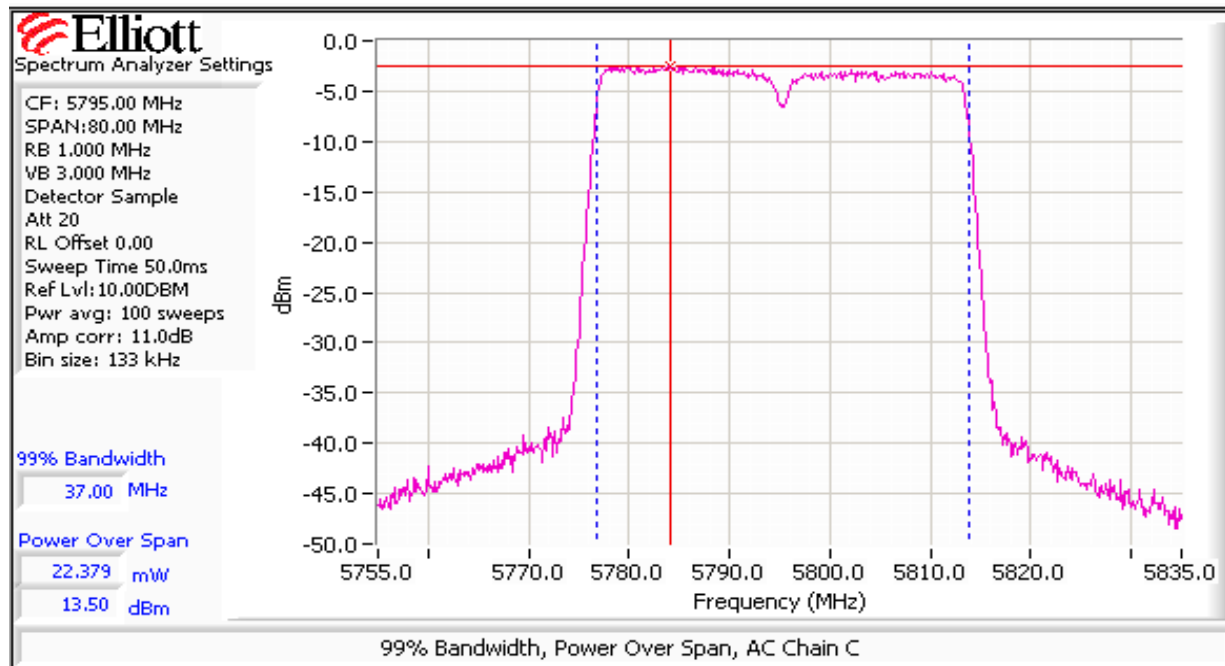
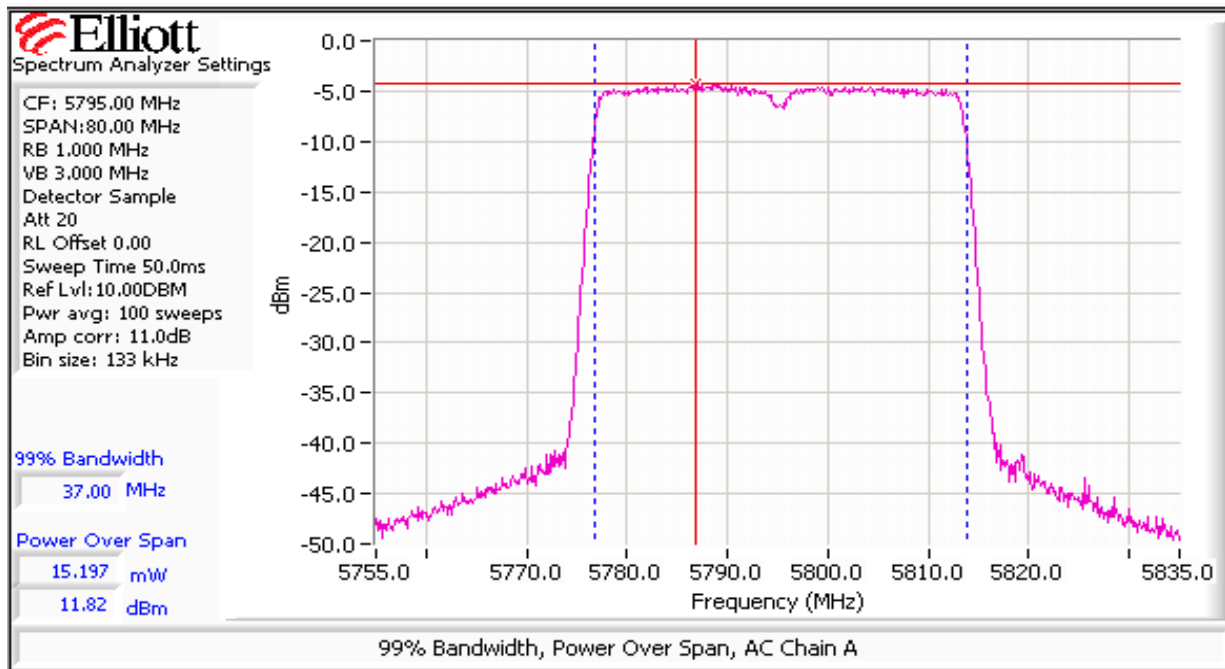

Client: Xirrus	Job Number: J71456
Model: XN-16 and XN-8	T-Log Number: T71643
	Account Manager: Susan Pezli
Contact: Steve Smith	
Standard: -	Class: N/A

Run #2: Power spectral Density

Power Setting	Frequency (MHz)	PSD (dBm/3kHz) ^{Note 1}				Total	Limit dBm/3kHz	Result
		Chain 1	Chain 2	Chain 3	Chain 4			
17.0	5745	-4.5		-9.9		-3.4	8.0	Pass
17.0	5785	-5.9		-8.2		-3.9	8.0	Pass
17.0	5825	-2.9		-8.1		-1.8	8.0	Pass
17.0	5755	-14.7		-12.3		-10.3	8.0	Pass
17.0	5795	-12.0		-13.8		-9.8	8.0	Pass

- Note 1: Power spectral density measured using RB=3 kHz, VB=10kHz, analyzer with peak detector and with a sweep time set to ensure a dwell time of at least 1 second per 3kHz. The measurement is made at the frequency of PPSD determined from preliminary scans using RB=3kHz using multiple sweeps at a faster rate over the 6dB bandwidth of the signal.
- Note 2: The operation of multiple radios in the band does not affect power spectral density as radios cannot operate on overlapping channels.

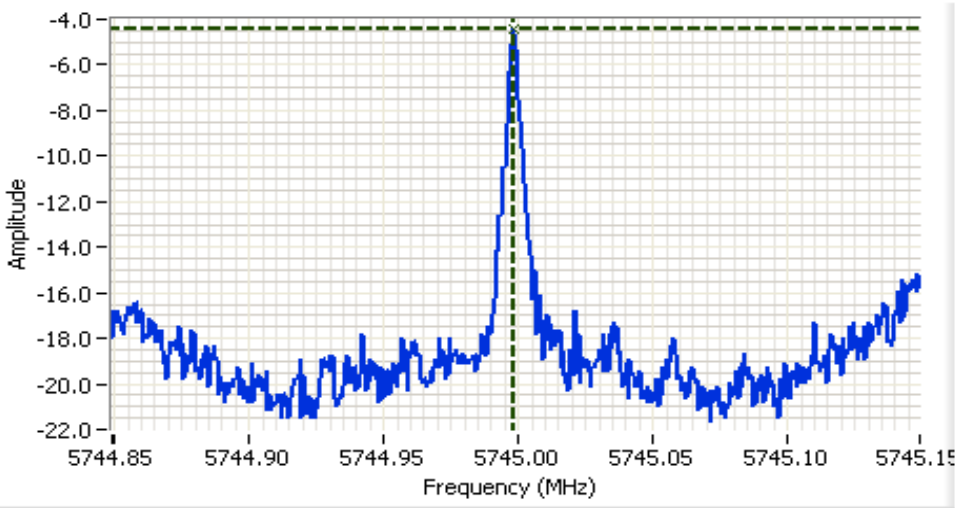

Analyzer Settings

HP8564E,006,EMI,UK6
 CF: 5744.999 MHz
 SPAN:300 kHz
 RB 3.00 kHz
 VB 10.00 kHz
 Detector POS
 Att 10
 RL Offset 8.00
 Sweep Time 100.0s
 Ref Lvl:-2.80DBM

Comments

PSD: -4.5 dBm/3kHz
 802.11n 20MHz
 Chain A

Cursor 1 5744.9980 -4.47 [Icons]

 0.0000 0.00 [Icons]



Client: Xirrus	Job Number: J71456
Model: XN-16 and XN-8	T-Log Number: T71643
Contact: Steve Smith	Account Manager: Susan Pezli
Standard: -	Class: N/A

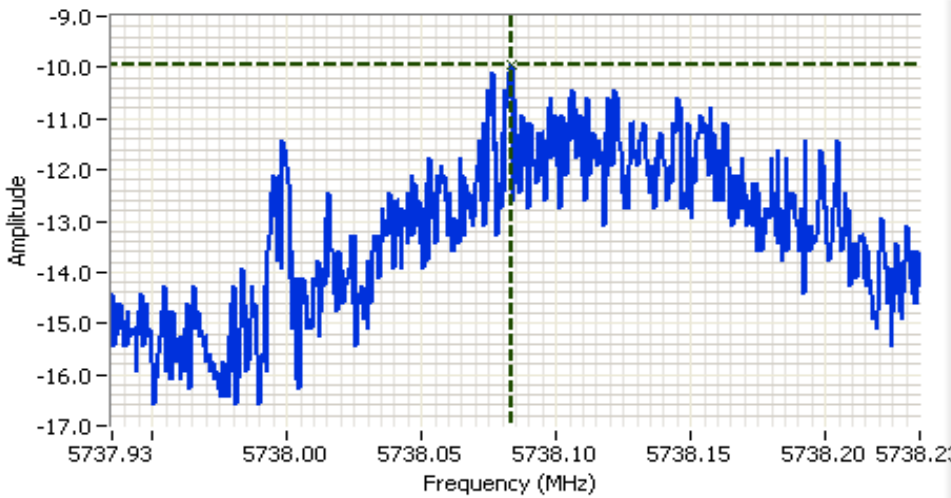

Analyzer Settings
 HP8564E,006,EMI,UK6
 CF: 5738.085 MHz
 SPAN:300 kHz
 RB 3.00 kHz
 VB 10.00 kHz
 Detector POS
 Att 10
 RL Offset 8.00
 Sweep Time 100.0s
 Ref Lvl:-8.60DBM

Comments
 PSD: -9.9 dBm/3kHz
 802.11n 20MHz
 Chain C

Cursor 1 5738.0835 -9.93 [Icons]
 0.0000 0.00 [Icons]

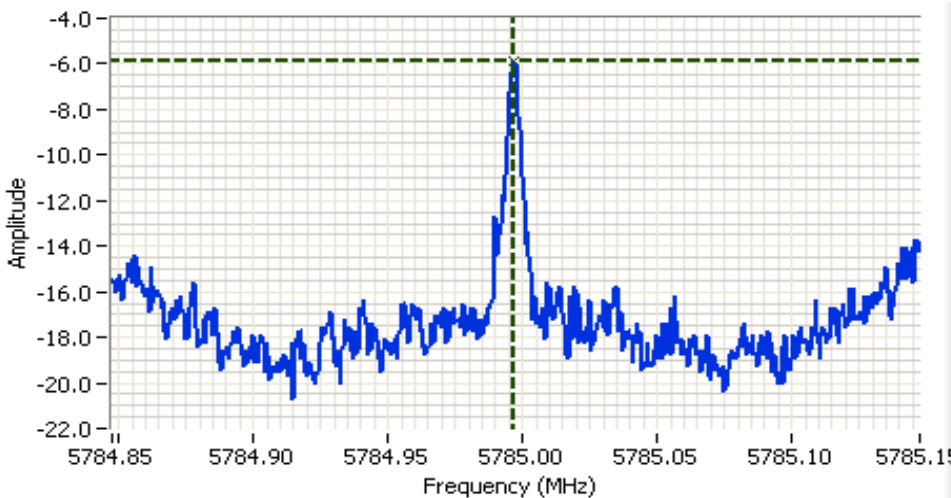

Analyzer Settings
 HP8564E,006,EMI,UK6
 CF: 5784.998 MHz
 SPAN:300 kHz
 RB 3.00 kHz
 VB 10.00 kHz
 Detector POS
 Att 10
 RL Offset 8.00
 Sweep Time 100.0s
 Ref Lvl:-2.90DBM

Comments
 PSD: -5.9 dBm/3kHz
 802.11n 20MHz
 Chain A

Cursor 1 5784.9971 -5.90 [Icons]
 0.0000 0.00 [Icons]



Client: Xirrus	Job Number: J71456
Model: XN-16 and XN-8	T-Log Number: T71643
Contact: Steve Smith	Account Manager: Susan Pezl
Standard: -	Class: N/A

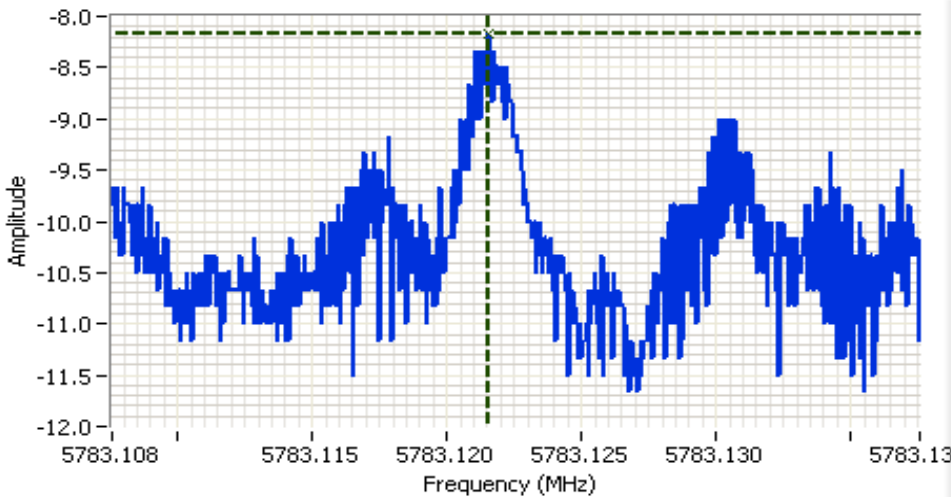

Analyzer Settings
 HP8564E,006,EMI,UK6
 CF: 5783.123 MHz
 SPAN:30.0 kHz
 RB 3.00 kHz
 VB 10.00 kHz
 Detector POS
 Att 10
 RL Offset 8.00
 Sweep Time 100.0s
 Ref Lvl:-4.50DBM

Comments
 PSD: -8.2 dBm/3kHz
 802.11n 20MHz
 Chain C

Cursor 1 5783.1216 -8.17

0.0000 0.00

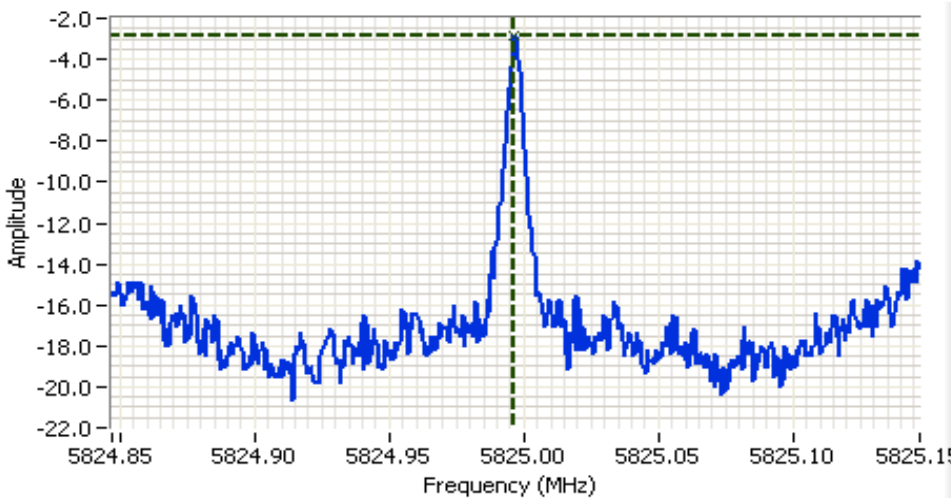

Analyzer Settings
 HP8564E,006,EMI,UK6
 CF: 5824.997 MHz
 SPAN:300 kHz
 RB 3.00 kHz
 VB 10.00 kHz
 Detector POS
 Att 10
 RL Offset 8.00
 Sweep Time 100.0s
 Ref Lvl:-1.20DBM

Comments
 PSD: -2.9 dBm/3kHz
 802.11n 20MHz
 Chain A

Cursor 1 5824.9966 -2.87

0.0000 0.00



Client: Xirrus	Job Number: J71456
Model: XN-16 and XN-8	T-Log Number: T71643
Contact: Steve Smith	Account Manager: Susan Pezli
Standard: -	Class: N/A

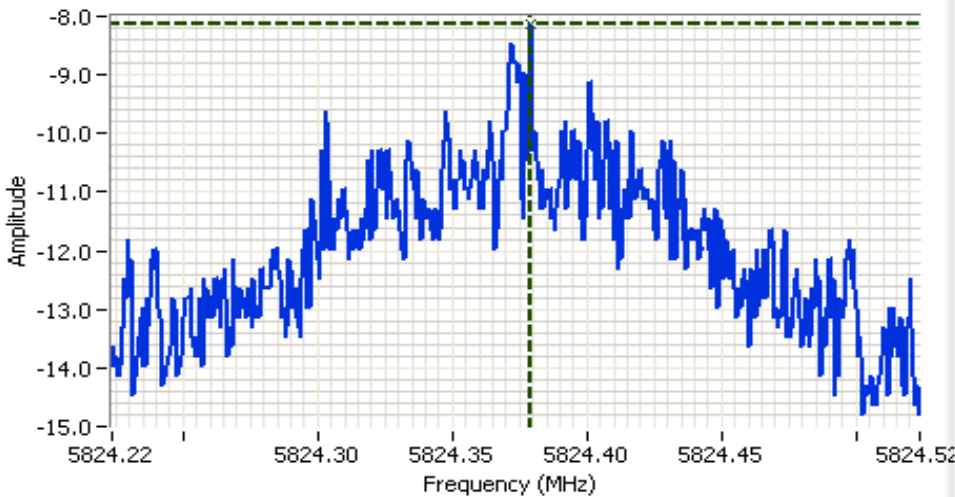

Analyzer Settings

HP8564E,006,EMI,UK6
 CF: 5824.374 MHz
 SPAN:300 kHz
 RB 3.00 kHz
 VB 10.00 kHz
 Detector POS
 Att 10
 RL Offset 8.00
 Sweep Time 100.0s
 Ref Lvl:-6.80DBM

Comments

PSD: -8.1 dBm/3kHz
 802.11n 20MHz
 Chain C

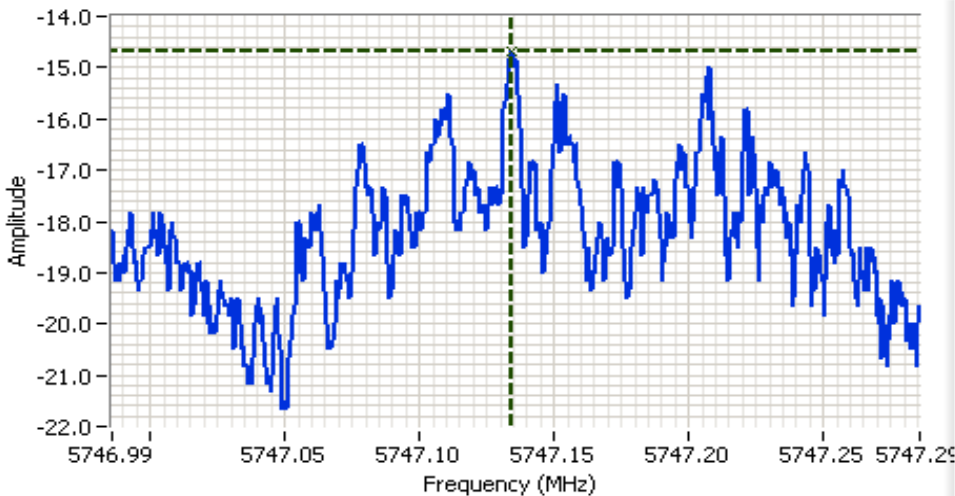
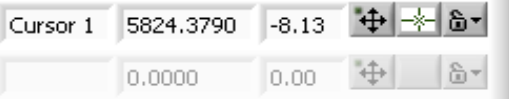

Analyzer Settings

HP8564E
 CF: 5747.136 MHz
 SPAN:300 kHz
 RB 3.00 kHz
 VB 10.00 kHz
 Detector POS
 Att 20
 RL Offset 11.00
 Sweep Time 100.0s
 Ref Lvl:21.00DBM

Comments

PSD: -14.67 dBm/3kHz
 80211n(n40)
 AC Chain A
 5755 MHz

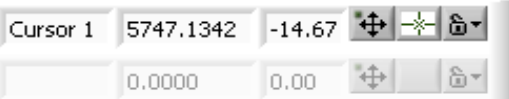

Client: Xirrus	Job Number: J71456
Model: XN-16 and XN-8	T-Log Number: T71643
Contact: Steve Smith	Account Manager: Susan Pezli
Standard: -	Class: N/A

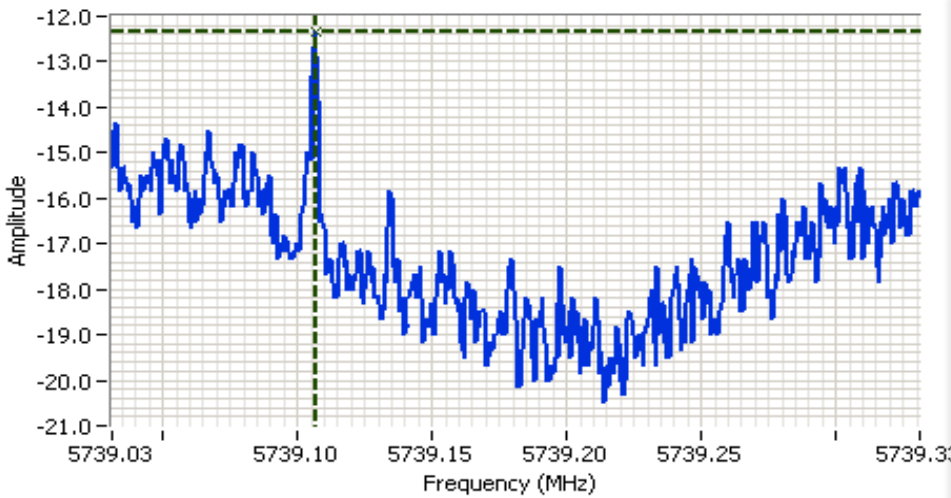

Analyzer Settings

HP8564E
 CF: 5739.181 MHz
 SPAN:300 kHz
 RB 3.00 kHz
 VB 10.00 kHz
 Detector POS
 Att 20
 RL Offset 11.00
 Sweep Time 100.0s
 Ref Lvl:21.00DBM

Comments

PSD: -12.33 dBm/3kHz
 80211n(n40)
 AC Chain C
 5755 MHz

Cursor 1 5739.1067 -12.33

0.0000 0.00

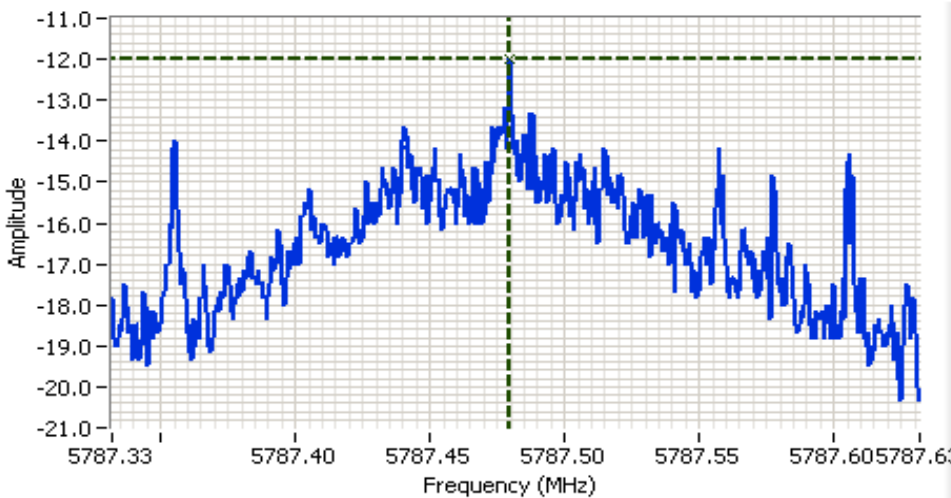

Analyzer Settings

HP8564E
 CF: 5787.482 MHz
 SPAN:300 kHz
 RB 3.00 kHz
 VB 10.00 kHz
 Detector POS
 Att 20
 RL Offset 11.00
 Sweep Time 100.0s
 Ref Lvl:21.00DBM

Comments

PSD: -12.0 dBm/3kHz
 80211n(n40)
 AC Chain A
 5795 MHz

Cursor 1 5787.4799 -12.00

0.0000 0.00



Client: Xirrus	Job Number: J71456
Model: XN-16 and XN-8	T-Log Number: T71643
	Account Manager: Susan Pezli
Contact: Steve Smith	
Standard: -	Class: N/A

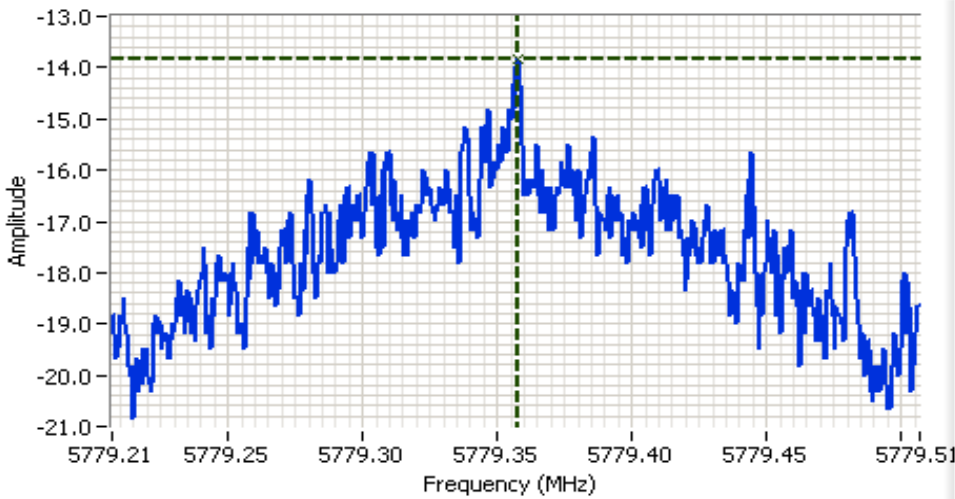

Analyzer Settings

HP8564E
 CF: 5779.357 MHz
 SPAN: 300 kHz
 RB 3.00 kHz
 VB 10.00 kHz
 Detector POS
 Att 20
 RL Offset 11.00
 Sweep Time 100.0s
 Ref Lvl: 21.00DBM

Comments

PSD: -13.83 dBm/3kHz
 80211n(n40)
 AC Chain C
 5795 MHz

Cursor 1 5779.3579 -13.83

0.0000 0.00



Client: Xirrus	Job Number: J71456
Model: XN-16 and XN-8	T-Log Number: T71643
	Account Manager: Susan Pezli
Contact: Steve Smith	
Standard: -	Class: N/A

Run #3: Signal Bandwidth

Mode	Power Setting	Frequency (MHz)	Resolution Bandwidth	Chain A		Chain C	
				Bandwidth (MHz) 6dB	99%	Bandwidth (MHz) 6dB	99%
802.11n20	17	5745	100kHz	17.7	18.4	17.7	18.6
802.11n20	17	5785	100kHz	17.8	18.6	17.7	18.6
802.11n20	17	5825	100kHz	17.8	18.5	17.7	18.5
802.11n40	17	5755	100kHz	36.7	37.0	36.5	37.0
802.11n40	17	5795	100kHz	36.5	37.0	36.4	37.0

Note 1: Measured on each chain

Note 2: 99% bandwidth measured in accordance with RSS GEN, with RB > 1% of the span and VB > 3xRB

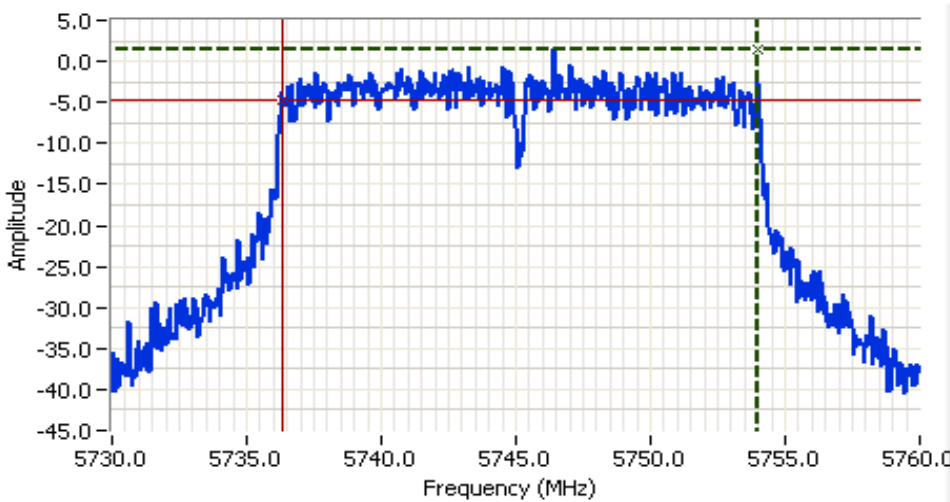

Analyzer Settings

HP8564E,006,EMI,UK6
 CF: 5745.000 MHz
 SPAN:30.000 MHz
 RB 100 kHz
 VB 100 kHz
 Detector POS
 Att 10
 RL Offset 8.00
 Sweep Time 50.0ms
 Ref Lvl:8.00DBM

Comments

6dB BW: 17.700 MHz
 802.11n 20MHz
 Chain C

Cursor 1	5754.0000	1.33	
Cursor 2	5736.3000	-4.67	

Delta Freq. 17.700
 Delta Amplitude 6.00



Client: Xirus	Job Number: J71456
Model: XN-16 and XN-8	T-Log Number: T71643
Contact: Steve Smith	Account Manager: Susan Pezli
Standard: -	Class: N/A

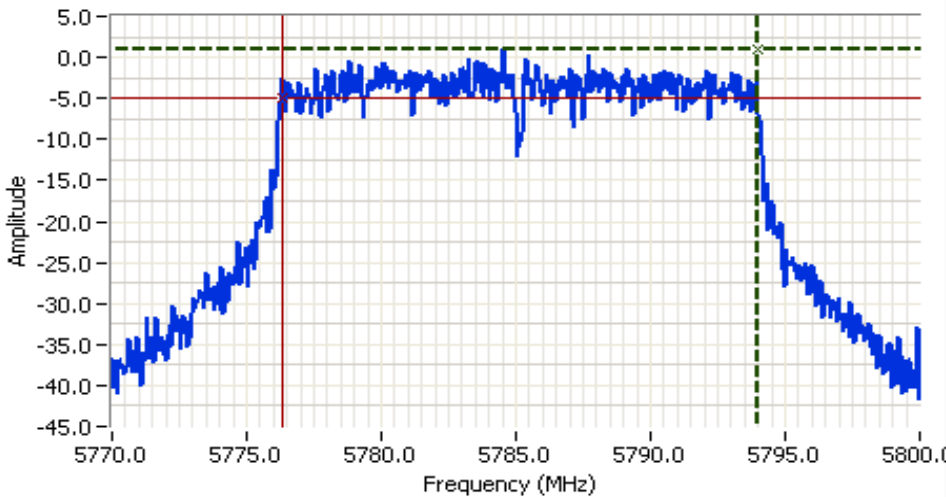

Analyzer Settings
 HP8564E,006,EMI,UK6
 CF: 5785.000 MHz
 SPAN:30.000 MHz
 RB 100 kHz
 VB 100 kHz
 Detector POS
 Att 10
 RL Offset 8.00
 Sweep Time 50.0ms
 Ref Lvl:8.00DBM

Comments
 6dB BW: 17.650 MHz
 802.11n 20MHz
 Chain C

Cursor 1 5793.9500 1.00

Cursor 2 5776.3000 -5.00

Delta Freq. 17.650

Delta Amplitude 6.00

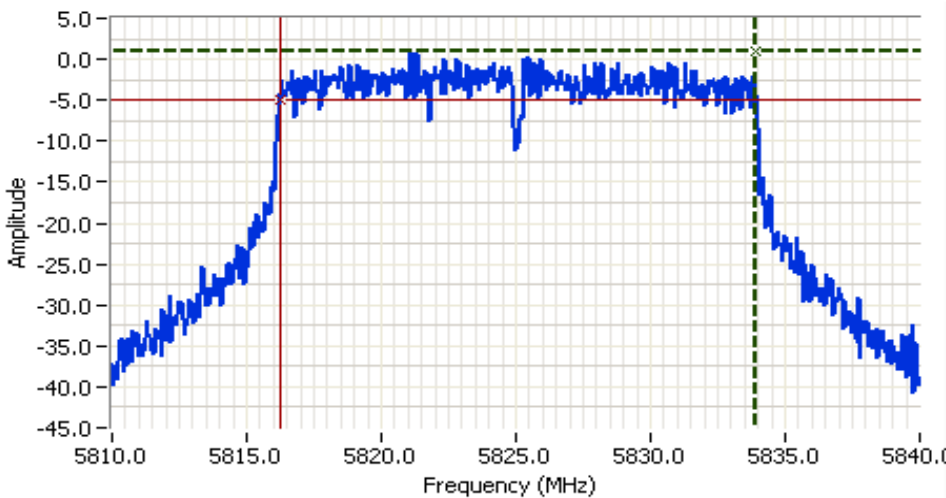

Analyzer Settings
 HP8564E,006,EMI,UK6
 CF: 5825.000 MHz
 SPAN:30.000 MHz
 RB 100 kHz
 VB 100 kHz
 Detector POS
 Att 10
 RL Offset 8.00
 Sweep Time 50.0ms
 Ref Lvl:8.00DBM

Comments
 6dB BW: 17.650 MHz
 802.11n 20MHz
 Chain C

Cursor 1 5833.9000 1.00

Cursor 2 5816.2500 -5.00

Delta Freq. 17.650

Delta Amplitude 6.00



Client: Xirrus	Job Number: J71456
Model: XN-16 and XN-8	T-Log Number: T71643
Contact: Steve Smith	Account Manager: Susan Pezli
Standard: -	Class: N/A

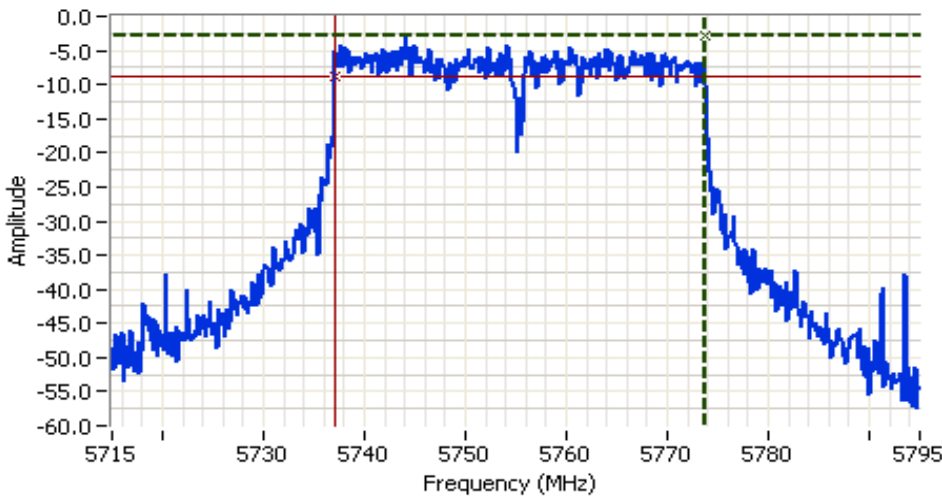

Analyzer Settings
 HP8564E,006,EMI,UK6
 CF: 5755.000 MHz
 SPAN:80.000 MHz
 RB 100 kHz
 VB 100 kHz
 Detector POS
 Att 10
 RL Offset 8.00
 Sweep Time 50.0ms
 Ref Lvl:2.30DBM

Comments
 6dB BW: 36.533 MHz
 802.11n 40MHz
 Chain C

Cursor 1	5773.6667	-2.87	
Cursor 2	5737.1333	-8.87	

Delta Freq. 36.533
 Delta Amplitude 6.00

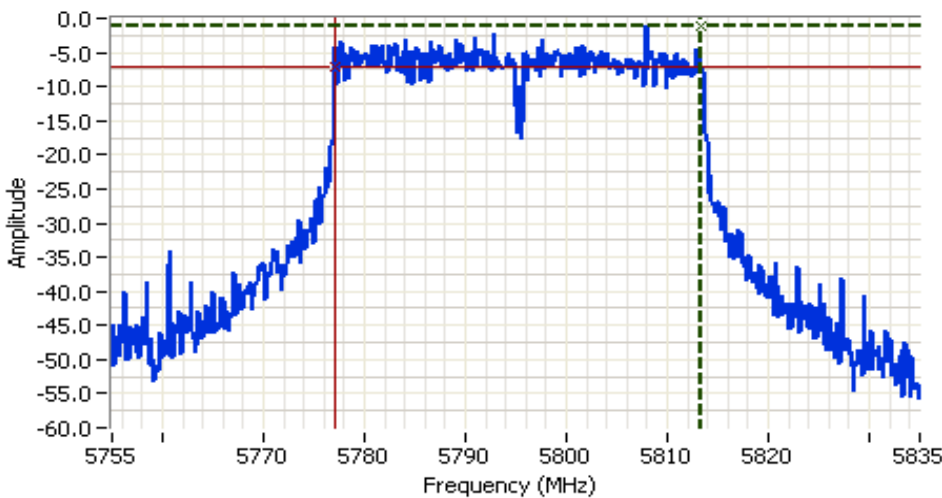

Analyzer Settings
 HP8564E,006,EMI,UK6
 CF: 5795.000 MHz
 SPAN:80.000 MHz
 RB 100 kHz
 VB 100 kHz
 Detector POS
 Att 10
 RL Offset 8.00
 Sweep Time 50.0ms
 Ref Lvl:2.30DBM

Comments
 6dB BW: 36.400 MHz
 802.11n 40MHz
 Chain C

Cursor 1	5813.4000	-1.20	
Cursor 2	5777.0000	-7.20	

Delta Freq. 36.400
 Delta Amplitude 6.00



Client: Xirrus	Job Number: J71456
Model: XN-16 and XN-8	T-Log Number: T71643
	Account Manager: Susan Pezli
Contact: Steve Smith	
Standard: -	Class: N/A

Run #4: Out of Band Spurious Emissions

Frequency (MHz)	Limit	Result
5745	-30dBc	Pass
5785	-30dBc	Pass
5825	-30dBc	Pass
5755	-30dBc	Pass
5795	-30dBc	Pass

Note 1: Measured using RB>=100kHz, VB>= RB

Plots for center channel - 802.11n 20MHz, power setting(s) = 17.0

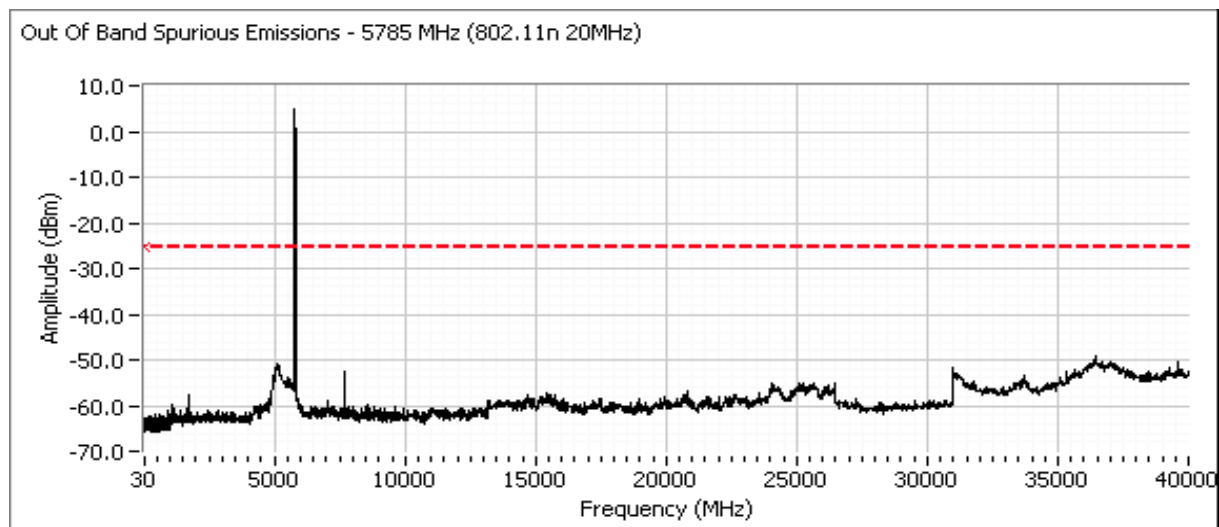

Client: Xirrus	Job Number: J71456
Model: XN-16 and XN-8	T-Log Number: T71643
	Account Manager: Susan Pezli
Contact: Steve Smith	
Standard: -	Class: N/A

Plots for low channel - 802.11n 20MHz, power setting(s) = 17.0

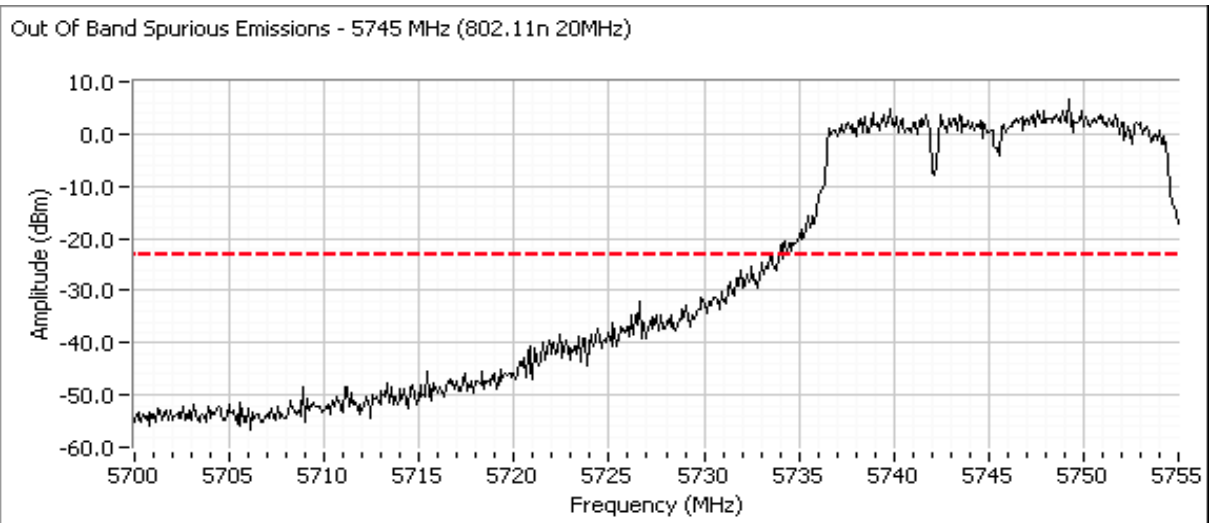
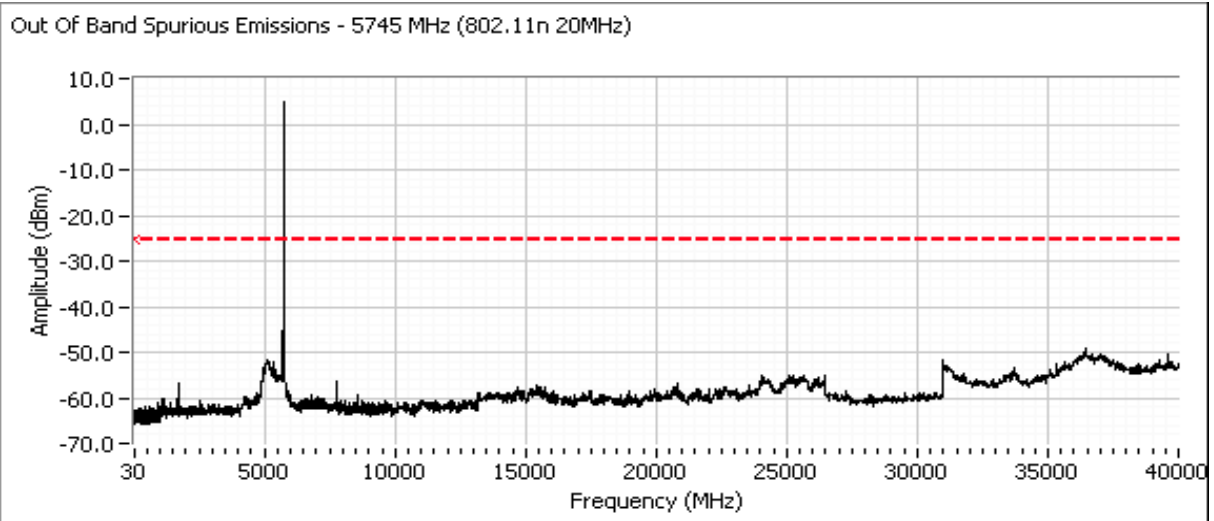

Client: Xirrus	Job Number: J71456
Model: XN-16 and XN-8	T-Log Number: T71643
	Account Manager: Susan Pezli
Contact: Steve Smith	
Standard: -	Class: N/A

Plots for high channel - 802.11n 20MHz, power setting(s) = 17.0

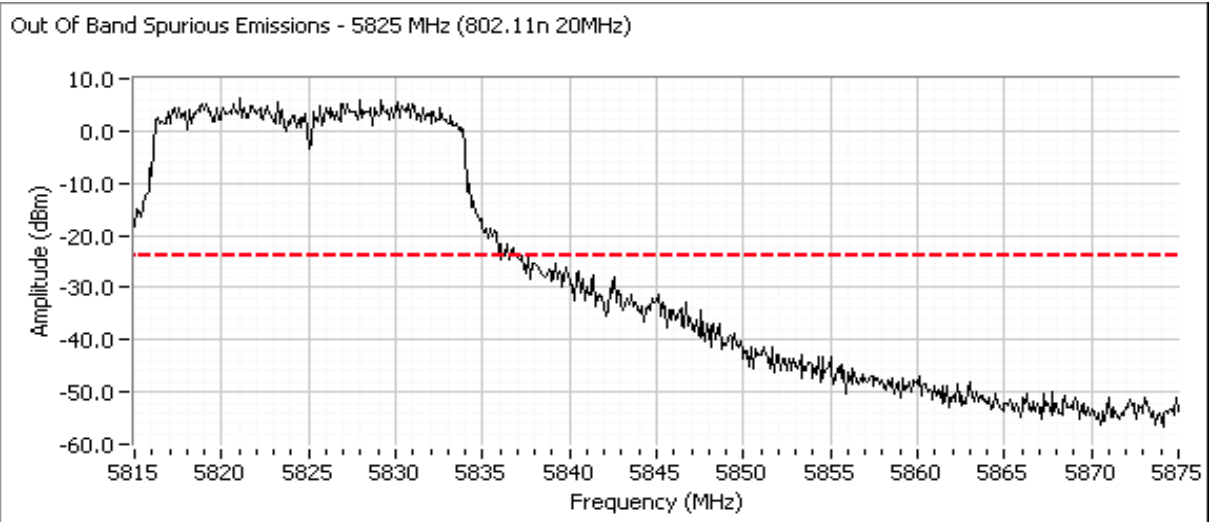
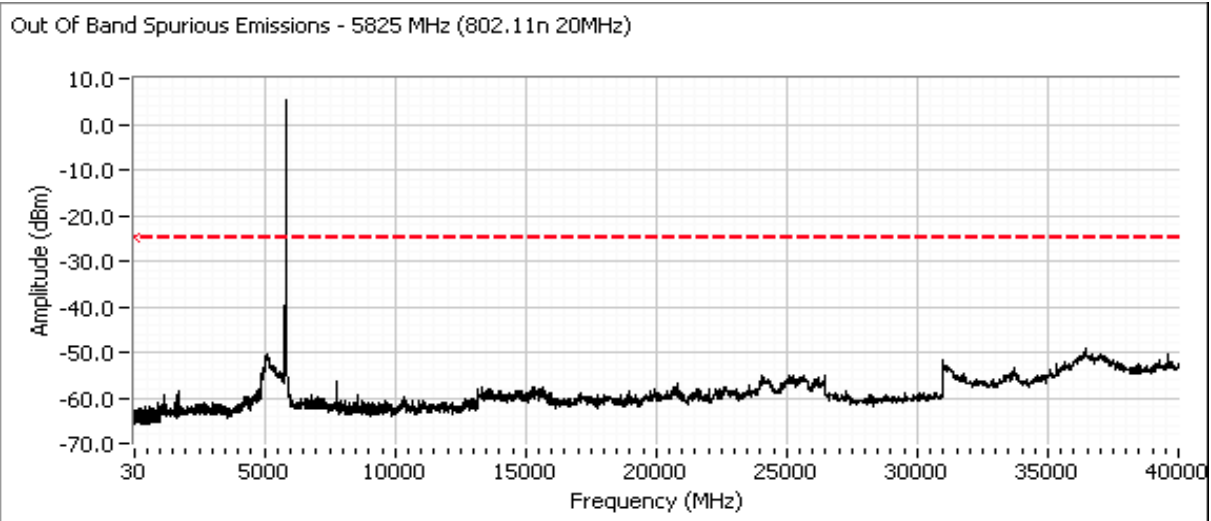

Client: Xirrus	Job Number: J71456
Model: XN-16 and XN-8	T-Log Number: T71643
	Account Manager: Susan Pezli
Contact: Steve Smith	
Standard: -	Class: N/A

Plots for low channel - 802.11n 40MHz, power setting(s) = 17.0

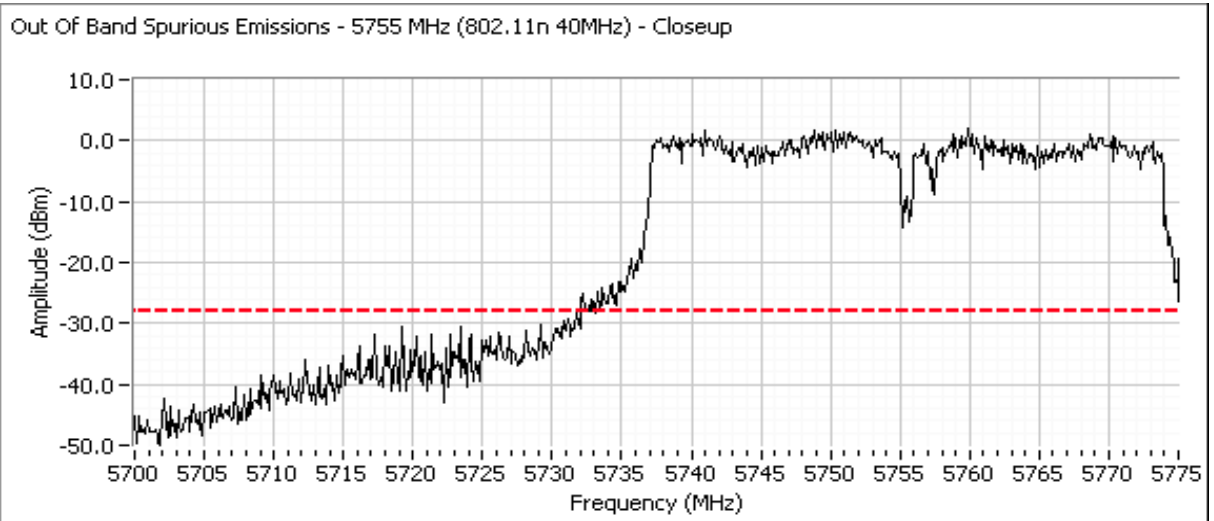
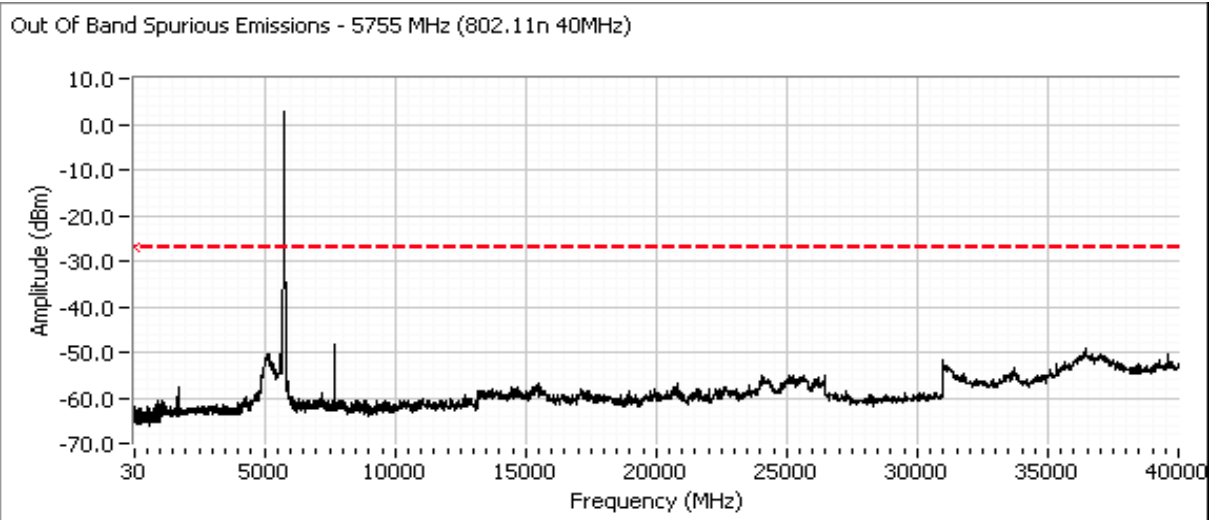

Client: Xirrus	Job Number: J71456
Model: XN-16 and XN-8	T-Log Number: T71643
	Account Manager: Susan Pezli
Contact: Steve Smith	
Standard: -	Class: N/A

Plots for high channel - 802.11n 40MHz, power setting(s) = 17.0

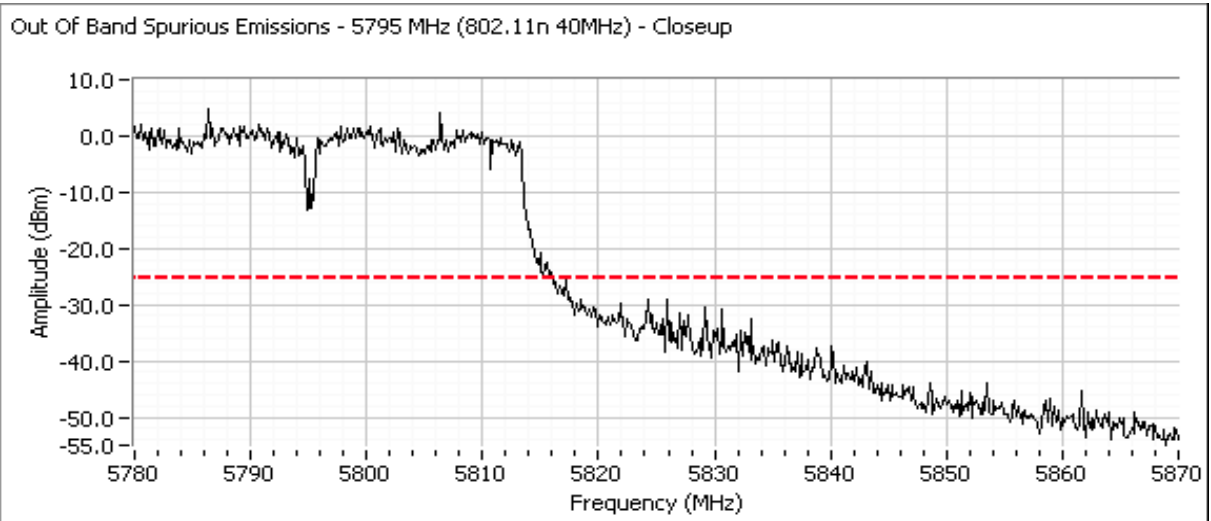
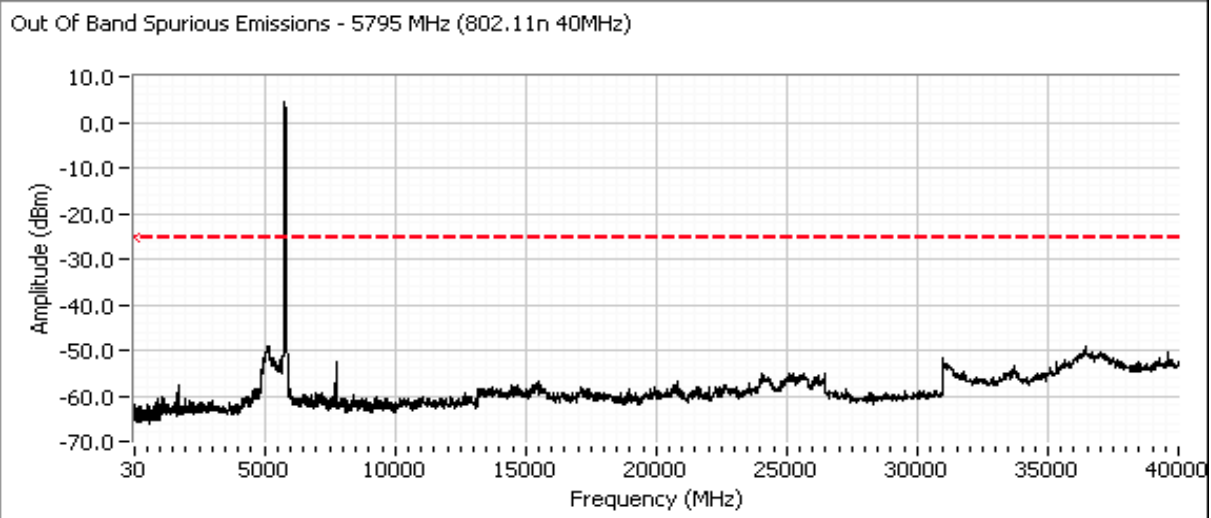



EMC Test Data

Client:	Xirrus	Job Number:	J71456
Model:	XN16 and XN8	T-Log Number:	T71641
		Account Manager:	Susan Pelzl
Contact:	Steve Smith		Mark Briggs
Emissions Standard(s):	FCC 15.247 / RSS 210	Class:	DTS
Immunity Standard(s):	-	Environment:	Wireless

DTS Radiated Emissions Test Data

For The

Xirrus

Model

XN16 and XN8

Date of Last Test: 6/6/2008

Client: Xirrus	Job Number: J71456
Model: XN16 and XN8	T-Log Number: T71641
	Account Manager: Susan Pelzi
Contact: Steve Smith	
Standard: FCC 15.247 / RSS 210	Class: N/A

RSS 210 and FCC 15.247 (DTS) Radiated Spurious Emissions 2390 MHz and 2483.5 MHz Restricted Band Edges, Internal Antenna

Test Specific Details

Objective: The objective of this test session is to perform final qualification testing of the EUT with respect to the specification listed above.

General Test Configuration

The EUT and all local support equipment were located on the turntable for radiated spurious emissions testing. All remote support equipment was located approximately 30 meters from the EUT with all I/O connections running on top of the groundplane.

For radiated emissions testing the measurement antenna was located 3 meters from the EUT.

Ambient Conditions:

Temperature:	22 - 30 °C
Rel. Humidity:	29 - 35 %

Modifications Made During Testing

No modifications were made to the EUT during testing

Deviations From The Standard

No deviations were made from the requirements of the standard.

Client: Xirrus	Job Number: J71456
Model: XN16 and XN8	T-Log Number: T71641
	Account Manager: Susan Pezli
Contact: Steve Smith	
Standard: FCC 15.247 / RSS 210	Class: N/A

Summary of Results - Device Operating in the 2400-2483.5 MHz Band

Run #	Mode	Channel	Power Setting	Test Performed	Limit	Result / Margin
1a	802.11b Chain A	2412	18.5	Restricted Band Edge (2390 MHz)	FCC Part 15.209 / 15.247(c)	53.8dBµV/m (489.8µV/m) @ 2385.5MHz (-0.2dB)
1b		2462	18.5	Restricted Band Edge (2483.5 MHz)	FCC Part 15.209 / 15.247(c)	53.9dBµV/m (495.5µV/m) @ 2483.5MHz (-0.1dB)
2a	802.11b Chain A+B+C	2412	17.5	Restricted Band Edge (2390 MHz)	FCC Part 15.209 / 15.247(c)	52.3dBµV/m (412.1µV/m) @ 2389.8MHz (-1.7dB)
2b		2462	17.5	Restricted Band Edge (2483.5 MHz)	FCC Part 15.209 / 15.247(c)	52.2dBµV/m (407.4µV/m) @ 2488.0MHz (-1.8dB)
3a	802.11g Chain A	2412	13.5	Restricted Band Edge (2390 MHz)	FCC Part 15.209 / 15.247(c)	53.9dBµV/m (495.5µV/m) @ 2389.9MHz (-0.1dB)
3b		2462	14.5	Restricted Band Edge (2483.5 MHz)	FCC Part 15.209 / 15.247(c)	52.3dBµV/m (412.1µV/m) @ 2483.5MHz (-1.7dB)
4a	802.11g Chain A+B+C	2412	14.5	Restricted Band Edge (2390 MHz)	FCC Part 15.209 / 15.247(c)	52.4dBµV/m (416.9µV/m) @ 2390.0MHz (-1.6dB)
4b		2462	13.5	Restricted Band Edge (2483.5 MHz)	FCC Part 15.209 / 15.247(c)	51.0dBµV/m (354.8µV/m) @ 2484.0MHz (-3.0dB)
5a	802.11n20 Chain A+B+C	2412	13.0	Restricted Band Edge (2390 MHz)	FCC Part 15.209 / 15.247(c)	53.8dBµV/m (489.8µV/m) @ 2389.9MHz (-0.2dB)
5b		2462	9.5	Restricted Band Edge (2483.5 MHz)	FCC Part 15.209 / 15.247(c)	52.1dBµV/m (402.7µV/m) @ 2483.7MHz (-1.9dB)
6a	802.11n40 Chain A+B+C	2422	8.0	Restricted Band Edge (2390 MHz)	FCC Part 15.209 / 15.247(c)	53.6dBµV/m (478.6µV/m) @ 2389.7MHz (-0.4dB)
6b		2452	9.0	Restricted Band Edge (2483.5 MHz)	FCC Part 15.209 / 15.247(c)	53.5dBµV/m (473.2µV/m) @ 2483.6MHz (-0.5dB)



EMC Test Data

Client: Xirrus	Job Number: J71456
Model: XN16 and XN8	T-Log Number: T71641
	Account Manager: Susan Pezli
Contact: Steve Smith	
Standard: FCC 15.247 / RSS 210	Class: N/A

Run #1: Band-Edge Radiated Spurious Emissions. Operating Mode: 802.11b, Single Chain

Date of Test: 5/14/2008	Config. Used: 1
Test Engineer: Mehran Birgani	Config Change: None
Test Location: SVOATS #1	EUT Voltage: POE

Run #1a: 802.11b, Single Chain @ 2412 MHz with power setting of 18.5 dBm

Fundamental Signal Field Strength

Frequency MHz	Level dB μ V/m	Pol V/H	15.209 / 15.247		Detector Pk/QP/Avg	Azimuth degrees	Height meters	Comments
			Limit	Margin				
2411.330	105.8	V	-	-	AVG	94	1.8	RB 1.000 MHz; VB: 10 Hz
2411.130	108.9	V	-	-	PK	94	1.8	RB 1.000 MHz; VB: 1.000 MHz
2410.430	97.8	H	-	-	AVG	176	1.3	RB 1.000 MHz; VB: 10 Hz
2410.670	100.4	H	-	-	PK	176	1.3	RB 1.000 MHz; VB: 1.000 MHz

	V	H
Fundamental emission level @ 3m in 100kHz RBW:	104.4	98.2
Limit for emissions outside of restricted bands:	74.4 dB μ V/m	

Limit is -30dBc (UNII power measurement)

Band Edge Signal Field Strength

Frequency MHz	Level dB μ V/m	Pol V/H	15.209 / 15.247		Detector Pk/QP/Avg	Azimuth degrees	Height meters	Comments
			Limit	Margin				
2385.530	53.8	V	54.0	-0.2	AVG	94	1.8	RB 1.000 MHz; VB: 10 Hz
2377.000	63.8	V	74.0	-10.2	PK	94	1.8	RB 1.000 MHz; VB: 1.000 MHz

Note 1: The restricted band edge is at 2390 MHz. For emissions in restricted bands, the limit of 15.209 was used. For all other emissions, the limit was set 30dB below the level of the fundamental and measured in 100kHz.

Client: Xirrus	Job Number: J71456
Model: XN16 and XN8	T-Log Number: T71641
	Account Manager: Susan Pezli
Contact: Steve Smith	
Standard: FCC 15.247 / RSS 210	Class: N/A

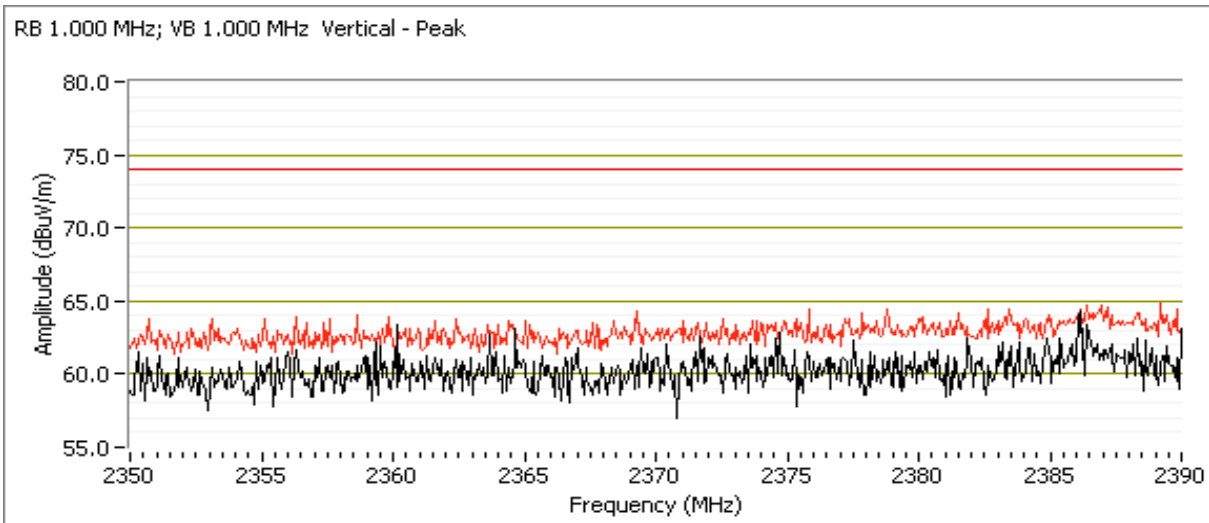
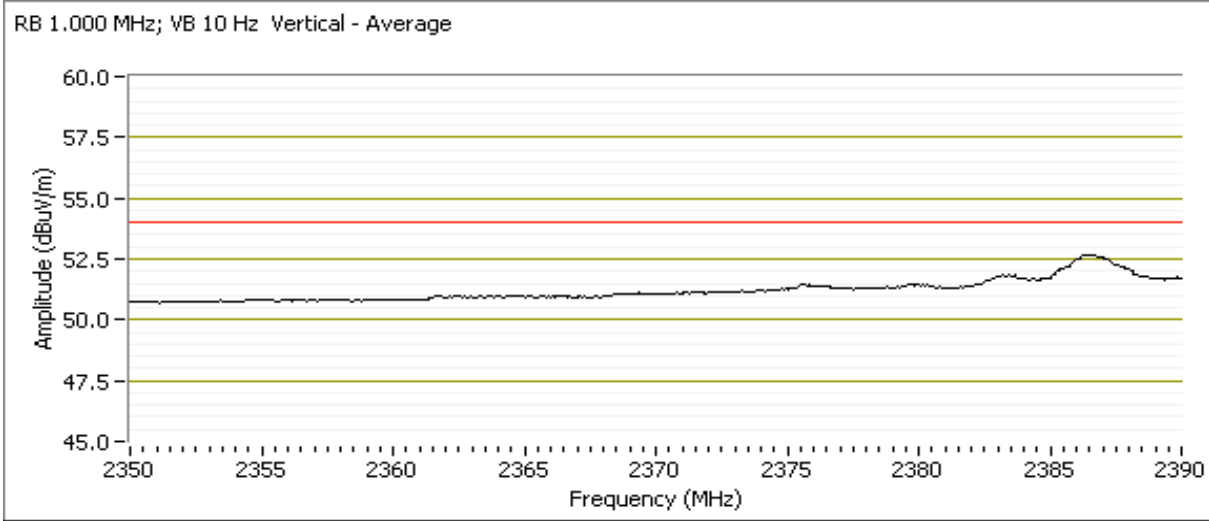

Client: Xirrus	Job Number: J71456
Model: XN16 and XN8	T-Log Number: T71641
	Account Manager: Susan Pezli
Contact: Steve Smith	
Standard: FCC 15.247 / RSS 210	Class: N/A

Run #1b: 802.11b, Single Chain @ 2462 MHz with power setting of 18.5 dBm.
Fundamental Signal Field Strength

Frequency MHz	Level dB μ V/m	Pol V/H	15.209 / 15.247		Detector Pk/QP/Avg	Azimuth degrees	Height meters	Comments
			Limit	Margin				
2461.200	107.3	V	-	-	AVG	191	1.6	RB 1.000 MHz; VB: 10 Hz
2463.130	110.2	V	-	-	PK	191	1.6	RB 1.000 MHz; VB: 1.000 MHz
2459.570	101.3	H	-	-	AVG	157	1.7	RB 1.000 MHz; VB: 10 Hz
2461.130	104.5	H	-	-	PK	157	1.7	RB 1.000 MHz; VB: 1.000 MHz

	V	H
Fundamental emission level @ 3m in 100kHz RBW:	105.8	100.2
Limit for emissions outside of restricted bands:	75.8 dB μ V/m	

Limit is -30dBc (UNII power measurement)

Band Edge Signal Field Strength

Frequency MHz	Level dB μ V/m	Pol V/H	15.209 / 15.247		Detector Pk/QP/Avg	Azimuth degrees	Height meters	Comments
			Limit	Margin				
2483.500	53.9	V	54.0	-0.1	AVG	191	1.6	RB 1.000 MHz; VB: 10 Hz
2483.770	62.4	V	74.0	-11.6	PK	191	1.6	RB 1.000 MHz; VB: 1.000 MHz

Note 1: The restricted band edge is at 2483.5 MHz. For emissions in restricted bands, the limit of 15.209 was used. For all other emissions, the limit was set 30dB below the level of the fundamental and measured in 100kHz.

Client: Xirrus	Job Number: J71456
Model: XN16 and XN8	T-Log Number: T71641
	Account Manager: Susan Pezli
Contact: Steve Smith	
Standard: FCC 15.247 / RSS 210	Class: N/A

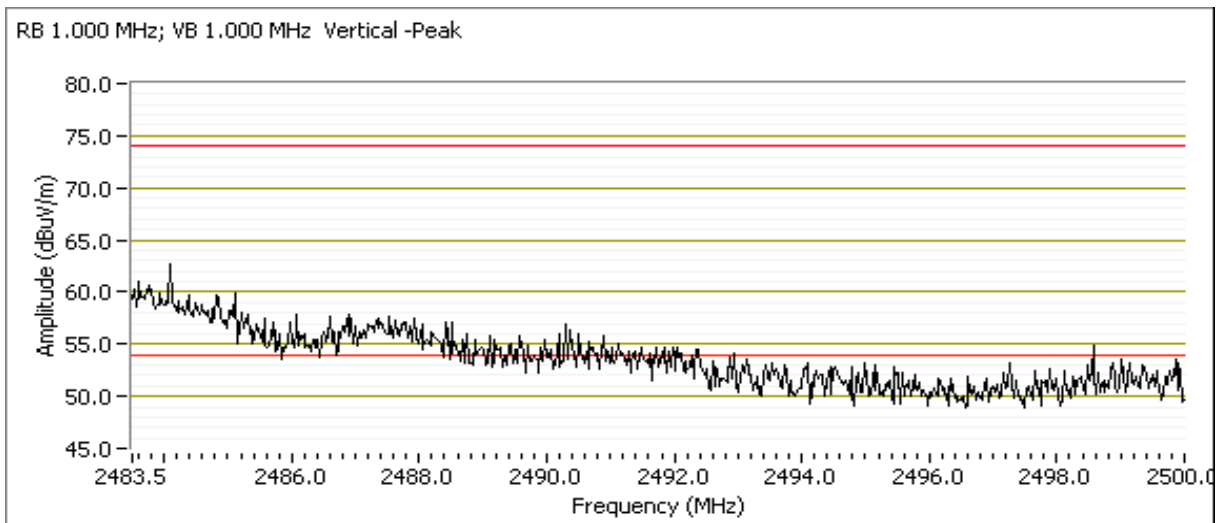
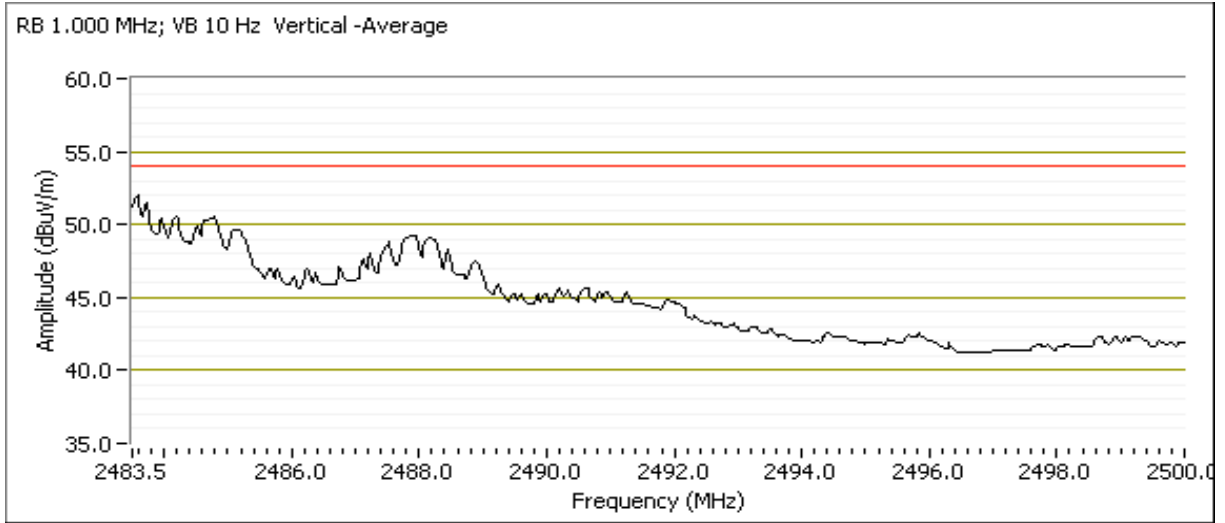

Client: Xirrus	Job Number: J71456
Model: XN16 and XN8	T-Log Number: T71641
Contact: Steve Smith	Account Manager: Susan Pezli
Standard: FCC 15.247 / RSS 210	Class: N/A

Run #2: Band-Edge Radiated Spurious Emissions. Operating Mode: 802.11b, All Chains Active

Date of Test: 5/21/2008	Config. Used: 1
Test Engineer: Mehran Birgani	Config Change: None
Test Location: SVOATS #1	EUT Voltage: POE

Run #2a: 802.11b, All Chains Active @ 2412 MHz with power setting of 17.5dBm.

Fundamental Signal Field Strength

Frequency	Level	Pol	15.209 / 15.247		Detector	Azimuth	Height	Comments
MHz	dB μ V/m	V/H	Limit	Margin	Pk/QP/Avg	degrees	meters	
2415.530	107.0	V	-	-	Avg	252	1.0	RB 1.000 MHz; VB: 10 Hz
2408.170	110.5	V	-	-	Pk	252	1.0	RB 1.000 MHz; VB: 1.000 MHz
2413.800	102.9	H	-	-	AVG	238	1.5	RB 1.000 MHz; VB: 10 Hz
2414.870	105.6	H	-	-	PK	238	1.5	RB 1.000 MHz; VB: 1.000 MHz

	V	H
Fundamental emission level @ 3m in 100kHz RBW:	104.7	101.4
Limit for emissions outside of restricted bands:	74.7 dB μ V/m	

Limit is -30dBc (UNII power measurement)

Band Edge Signal Field Strength

Frequency	Level	Pol	15.209 / 15.247		Detector	Azimuth	Height	Comments
MHz	dB μ V/m	V/H	Limit	Margin	Pk/QP/Avg	degrees	meters	
2389.800	52.3	V	54.0	-1.7	AVG	252	1.0	RB 1.000 MHz; VB: 10 Hz
2386.400	56.2	V	74.0	-17.8	PK	252	1.0	RB 1.000 MHz; VB: 1.000 MHz

Note 1: The restricted band edge is at 2390 MHz. For emissions in restricted bands, the limit of 15.209 was used. For all other emissions, the limit was set 30dB below the level of the fundamental and measured in 100kHz.

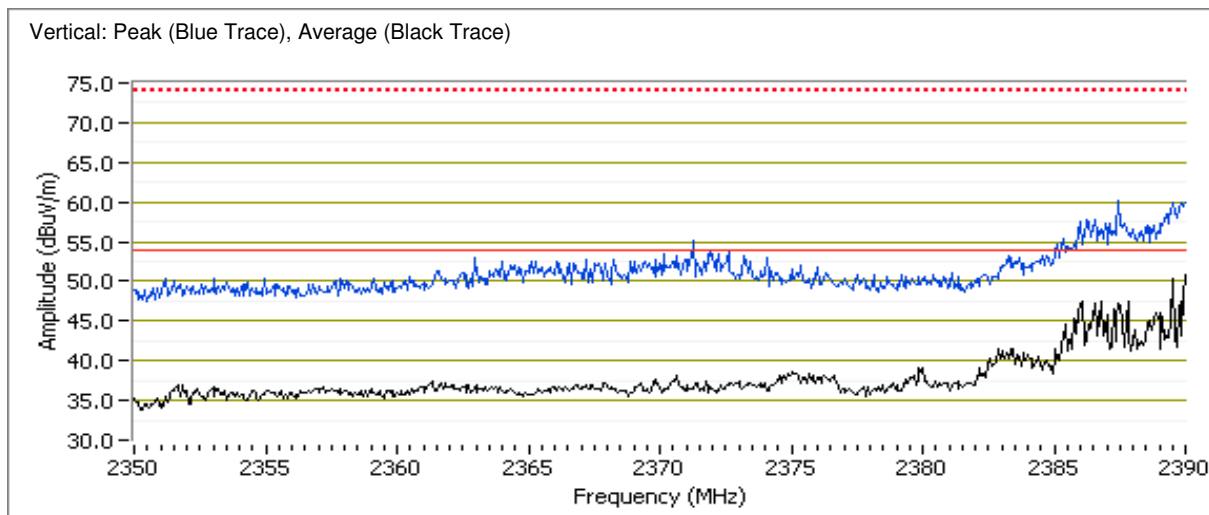

Client: Xirrus	Job Number: J71456
Model: XN16 and XN8	T-Log Number: T71641
Contact: Steve Smith	Account Manager: Susan Pezli
Standard: FCC 15.247 / RSS 210	Class: N/A

**Run #2b: 802.11b, All Chains Active @ 2462 MHz with power setting of 17.5dBm.
Fundamental Signal Field Strength**

Frequency MHz	Level dB μ V/m	Pol V/H	15.209 / 15.247		Detector Pk/QP/Avg	Azimuth degrees	Height meters	Comments
			Limit	Margin				
2458.800	106.6	H	-	-	AVG	247	1.1	RB 1.000 MHz; VB: 10 Hz
2458.630	110.3	H	-	-	PK	247	1.1	RB 1.000 MHz; VB: 1.000 MHz
2460.430	103.4	H	-	-	AVG	233	1.1	RB 1.000 MHz; VB: 10 Hz
2464.770	106.6	H	-	-	PK	233	1.1	RB 1.000 MHz; VB: 1.000 MHz

	V	H
Fundamental emission level @ 3m in 100kHz RBW:	106.0	103.2
Limit for emissions outside of restricted bands:	76.0 dB μ V/m	

Limit is -30dBc (UNII power measurement)

Band Edge Signal Field Strength

Frequency MHz	Level dB μ V/m	Pol V/H	15.209 / 15.247		Detector Pk/QP/Avg	Azimuth degrees	Height meters	Comments
			Limit	Margin				
2488.040	52.2	V	54.0	-1.8	AVG	247	1.1	RB 1.000 MHz; VB: 10 Hz
2488.120	61.3	V	74.0	-12.7	PK	247	1.1	RB 1.000 MHz; VB: 1.000 MHz

Note 1: The restricted band edge is at 2483.5 MHz. For emissions in restricted bands, the limit of 15.209 was used. For all other emissions, the limit was set 30dB below the level of the fundamental and measured in 100kHz.

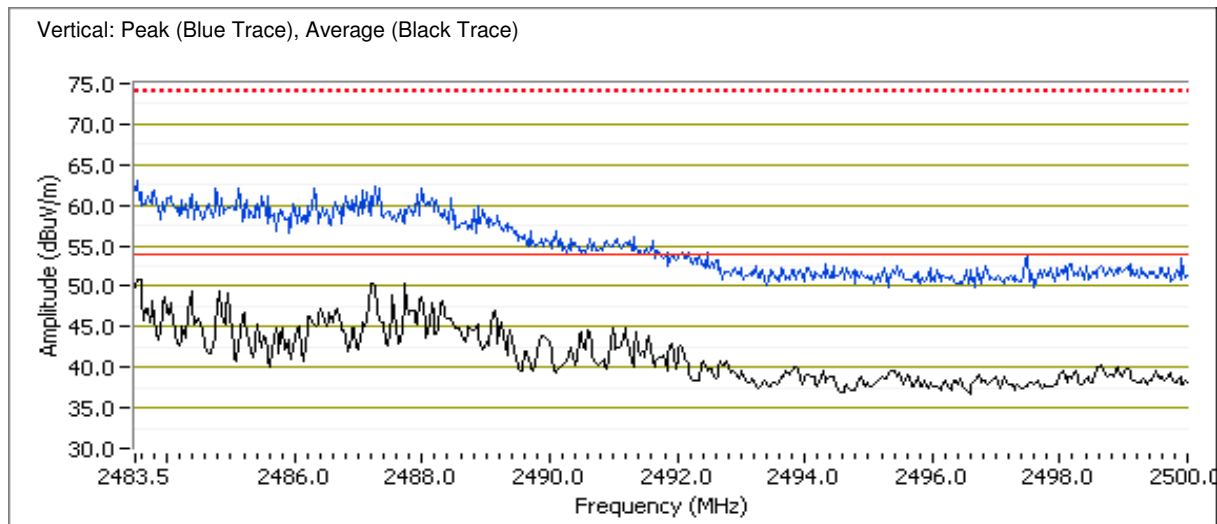

Client: Xirrus	Job Number: J71456
Model: XN16 and XN8	T-Log Number: T71641
	Account Manager: Susan Pezli
Contact: Steve Smith	
Standard: FCC 15.247 / RSS 210	Class: N/A

Run #3: Band-Edge Radiated Spurious Emissions. Operating Mode: 802.11g, Single Chain

Date of Test: 5/14/2008	Config. Used: 1
Test Engineer: Mehran Birgani	Config Change: None
Test Location: SVOATS #1	EUT Voltage: POE

Run #3a: 802.11g, Single Chain @ 2412 MHz with power setting of 13.5 dBm.

Fundamental Signal Field Strength

Frequency MHz	Level dB μ V/m	Pol V/H	15.209 / 15.247		Detector Pk/QP/Avg	Azimuth degrees	Height meters	Comments
			Limit	Margin				
2409.500	100.4	V	-	-	AVG	220	1.0	RB 1.000 MHz; VB: 10 Hz
2409.630	108.6	V	-	-	PK	220	1.0	RB 1.000 MHz; VB: 1.000 MHz
2414.300	97.5	H	-	-	AVG	167	1.5	RB 1.000 MHz; VB: 10 Hz
2414.430	106.7	H	-	-	PK	167	1.5	RB 1.000 MHz; VB: 1.000 MHz

	V	H
Fundamental emission level @ 3m in 100kHz RBW:	100.3	95.0
Limit for emissions outside of restricted bands:	70.3 dB μ V/m	

Limit is -30dBc (UNII power measurement)

Band Edge Signal Field Strength

Frequency MHz	Level dB μ V/m	Pol V/H	15.209 / 15.247		Detector Pk/QP/Avg	Azimuth degrees	Height meters	Comments
			Limit	Margin				
2389.930	53.9	V	54.0	-0.1	AVG	298	1.2	RB 1.000 MHz; VB: 10 Hz
2389.000	69.7	V	74.0	-4.3	PK	298	1.2	RB 1.000 MHz; VB: 1.000 MHz

Note 1: The restricted band edge is at 2390 MHz. For emissions in restricted bands, the limit of 15.209 was used. For all other emissions, the limit was set 30dB below the level of the fundamental and measured in 100kHz.

Client: Xirrus	Job Number: J71456
Model: XN16 and XN8	T-Log Number: T71641
	Account Manager: Susan Pezli
Contact: Steve Smith	
Standard: FCC 15.247 / RSS 210	Class: N/A

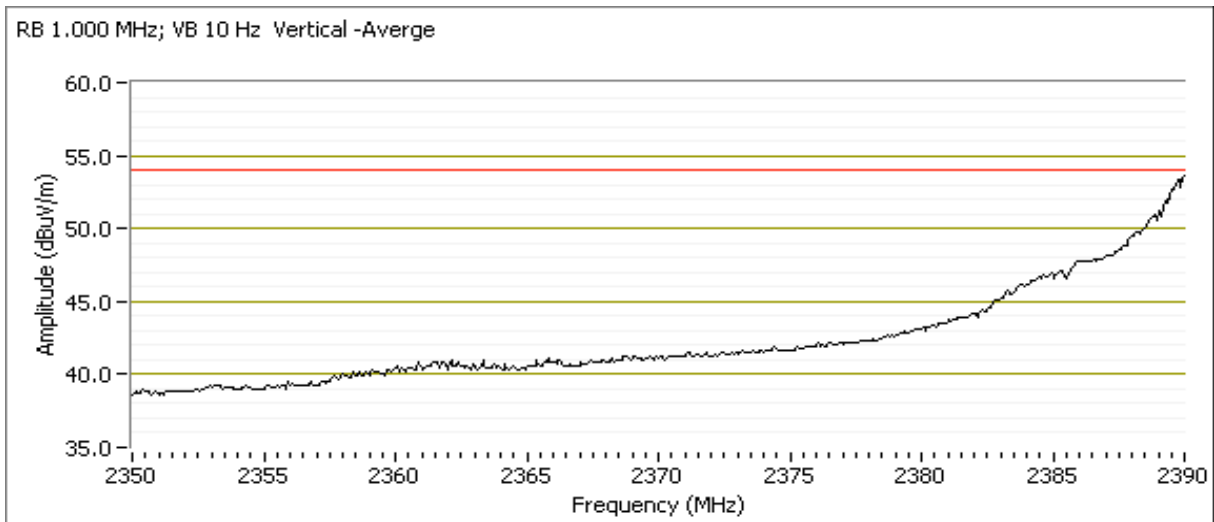
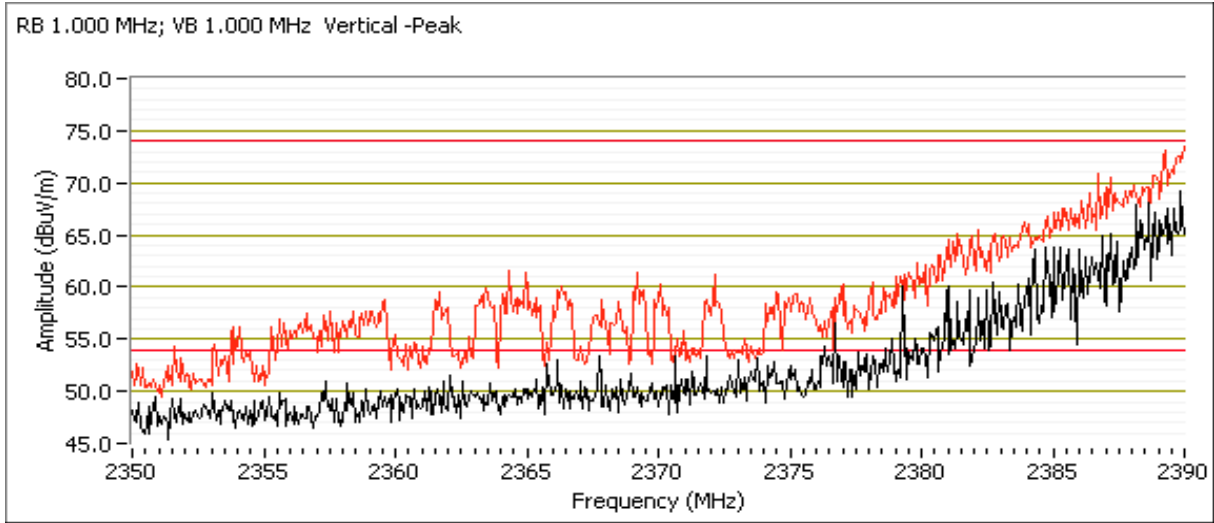

Client: Xirrus	Job Number: J71456
Model: XN16 and XN8	T-Log Number: T71641
	Account Manager: Susan Pezli
Contact: Steve Smith	
Standard: FCC 15.247 / RSS 210	Class: N/A

Run #3b: 802.11g, Single Chain @ 2462 MHz with power setting of 14.5 dBm.
Fundamental Signal Field Strength

Frequency MHz	Level dB μ V/m	Pol V/H	15.209 / 15.247		Detector Pk/QP/Avg	Azimuth degrees	Height meters	Comments
			Limit	Margin				
2459.800	100.8	V	-	-	AVG	193	1.0	RB 1.000 MHz; VB: 10 Hz
2461.930	108.9	V	-	-	PK	193	1.0	RB 1.000 MHz; VB: 1.000 MHz
2459.630	95.2	H	-	-	AVG	161	1.0	RB 1.000 MHz; VB: 10 Hz
2464.700	103.6	H	-	-	PK	161	1.0	RB 1.000 MHz; VB: 1.000 MHz

	V	H
Fundamental emission level @ 3m in 100kHz RBW:	98.6	93.1
Limit for emissions outside of restricted bands:	68.6 dB μ V/m	

Limit is -30dBc (UNII power measurement)

Band Edge Signal Field Strength

Frequency MHz	Level dB μ V/m	Pol V/H	15.209 / 15.247		Detector Pk/QP/Avg	Azimuth degrees	Height meters	Comments
			Limit	Margin				
2483.500	52.3	V	54.0	-1.7	AVG	193	1.0	RB 1.000 MHz; VB: 10 Hz
2483.720	71.3	V	74.0	-2.7	PK	193	1.0	RB 1.000 MHz; VB: 1.000 MHz

Note 1: The restricted band edge is at 2483.5 MHz. For emissions in restricted bands, the limit of 15.209 was used. For all other emissions, the limit was set 30dB below the level of the fundamental and measured in 100kHz.

Client: Xirrus	Job Number: J71456
Model: XN16 and XN8	T-Log Number: T71641
Contact: Steve Smith	Account Manager: Susan Pezli
Standard: FCC 15.247 / RSS 210	Class: N/A

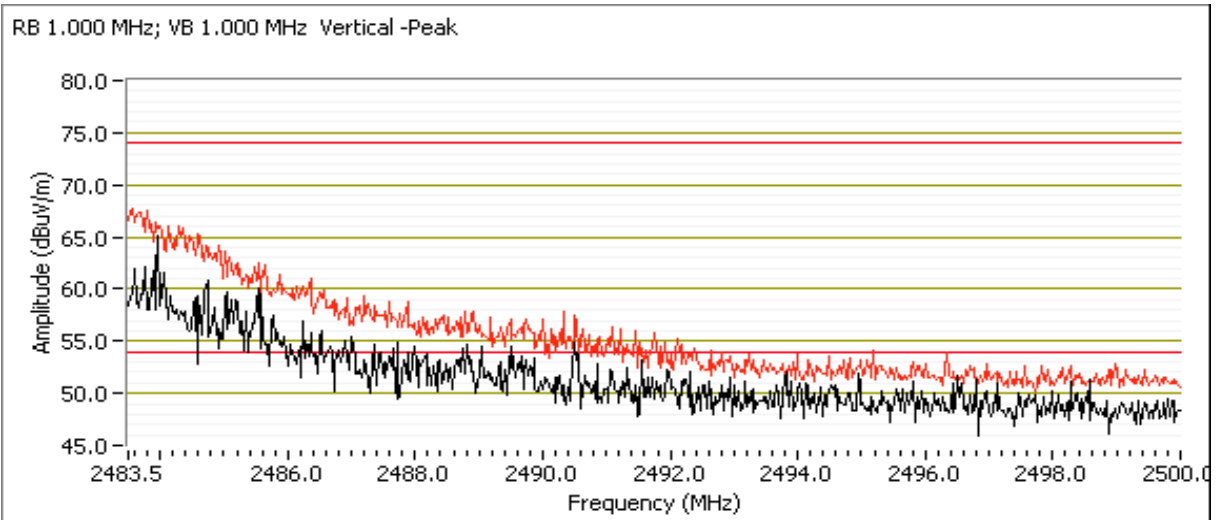
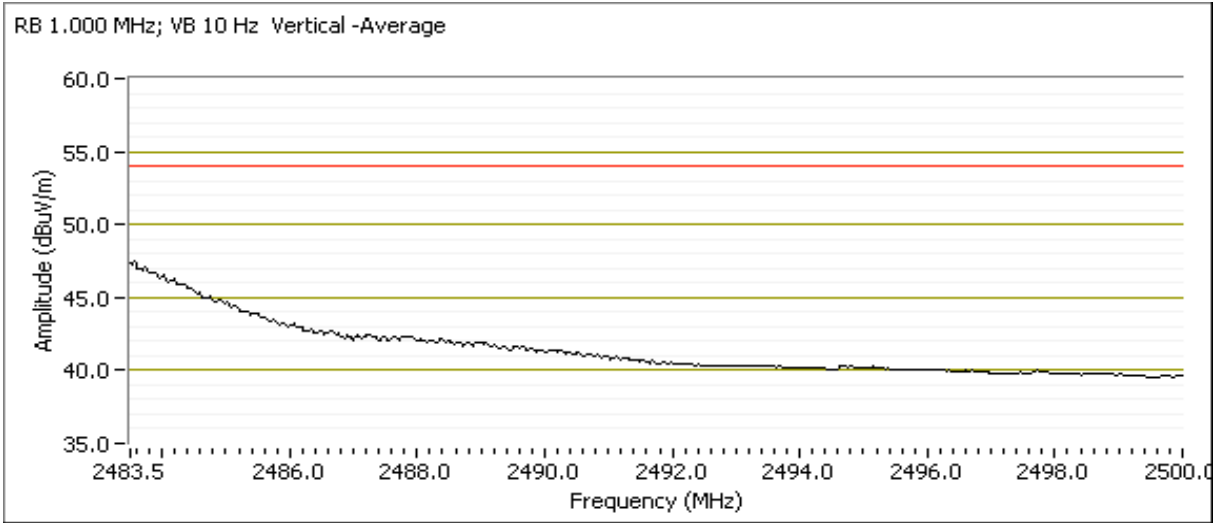

Client: Xirrus	Job Number: J71456
Model: XN16 and XN8	T-Log Number: T71641
	Account Manager: Susan Pezli
Contact: Steve Smith	
Standard: FCC 15.247 / RSS 210	Class: N/A

Run #4: Band-Edge Radiated Spurious Emissions. Operating Mode: 802.11g, All Chains Active

Date of Test: 5/21/2008	Config. Used: 1
Test Engineer: Mehran Birgani	Config Change: None
Test Location: SVOATS #1	EUT Voltage: POE

Run #4a: 802.11g, All Chains Active @ 2412 MHz with power setting of 14.5dBm.

Fundamental Signal Field Strength

Frequency MHz	Level dB μ V/m	Pol V/H	15.209 / 15.247		Detector Pk/QP/Avg	Azimuth degrees	Height meters	Comments
			Limit	Margin				
2410.530	99.3	V	-	-	AVG	240	1.0	RB 1.000 MHz; VB: 10 Hz
2415.030	109.5	V	-	-	PK	240	1.0	RB 1.000 MHz; VB: 1.000 MHz
2413.200	96.0	H	-	-	AVG	228	1.1	RB 1.000 MHz; VB: 10 Hz
2416.170	105.5	H	-	-	PK	228	1.1	RB 1.000 MHz; VB: 1.000 MHz

	V	H
Fundamental emission level @ 3m in 100kHz RBW:	101.5	98.4
Limit for emissions outside of restricted bands:	71.5 dB μ V/m	

Limit is -30dBc (UNII power measurement)

Band Edge Signal Field Strength

Frequency MHz	Level dB μ V/m	Pol V/H	15.209 / 15.247		Detector Pk/QP/Avg	Azimuth degrees	Height meters	Comments
			Limit	Margin				
2390.000	52.4	V	54.0	-1.6	AVG	240	1.0	RB 1.000 MHz; VB: 10 Hz
2389.130	68.7	V	74.0	-5.3	PK	240	1.0	RB 1.000 MHz; VB: 1.000 MHz

Note 1: The restricted band edge is at 2390 MHz. For emissions in restricted bands, the limit of 15.209 was used. For all other emissions, the limit was set 30dB below the level of the fundamental and measured in 100kHz.

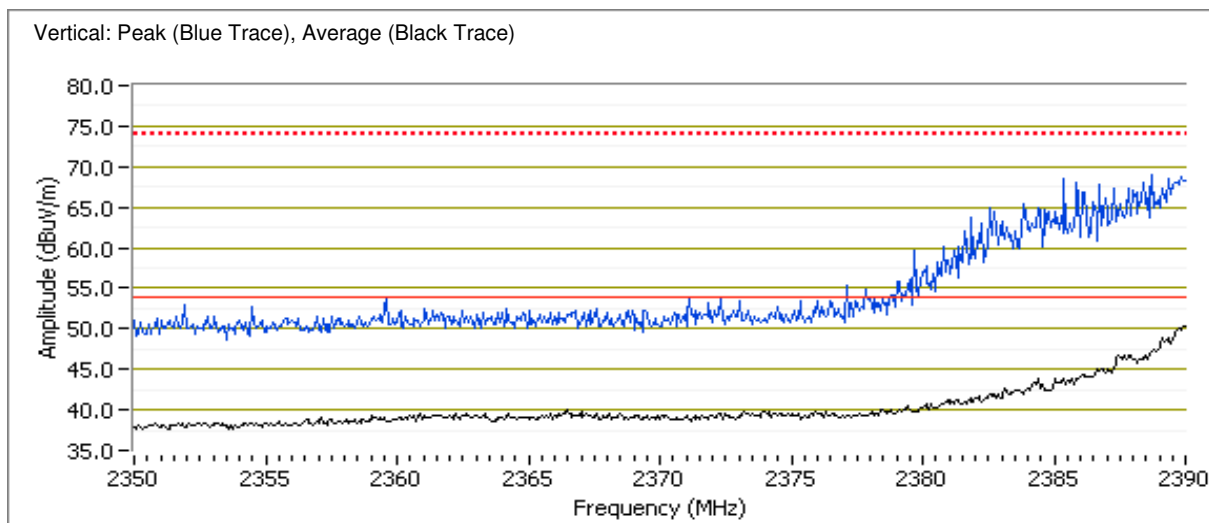

Client: Xirrus	Job Number: J71456
Model: XN16 and XN8	T-Log Number: T71641
	Account Manager: Susan Pezli
Contact: Steve Smith	
Standard: FCC 15.247 / RSS 210	Class: N/A

Run #4b: 802.11g, All Chains Active @ 2462 MHz with power setting of 13.5dBm.

Fundamental Signal Field Strength

Frequency MHz	Level dB μ V/m	Pol V/H	15.209 / 15.247		Detector Pk/QP/Avg	Azimuth degrees	Height meters	Comments
			Limit	Margin				
2458.470	99.4	V	-	-	AVG	243	1.0	RB 1.000 MHz; VB: 10 Hz
2460.370	108.6	V	-	-	PK	243	1.0	RB 1.000 MHz; VB: 1.000 MHz
2457.570	95.4	H	-	-	AVG	228	1.1	RB 1.000 MHz; VB: 10 Hz
2462.770	105.2	H	-	-	PK	228	1.1	RB 1.000 MHz; VB: 1.000 MHz

	V	H
Fundamental emission level @ 3m in 100kHz RBW:	101.1	95.6
Limit for emissions outside of restricted bands:	71.1 dB μ V/m	

Limit is -30dBc (UNII power measurement)

Band Edge Signal Field Strength

Frequency MHz	Level dB μ V/m	Pol V/H	15.209 / 15.247		Detector Pk/QP/Avg	Azimuth degrees	Height meters	Comments
			Limit	Margin				
2483.990	51.0	V	54.0	-3.0	AVG	243	1.0	RB 1.000 MHz; VB: 10 Hz
2483.940	69.8	V	74.0	-4.2	PK	243	1.0	RB 1.000 MHz; VB: 1.000 MHz

Note 1: The restricted band edge is at 2483.5 MHz. For emissions in restricted bands, the limit of 15.209 was used. For all other emissions, the limit was set 30dB below the level of the fundamental and measured in 100kHz.

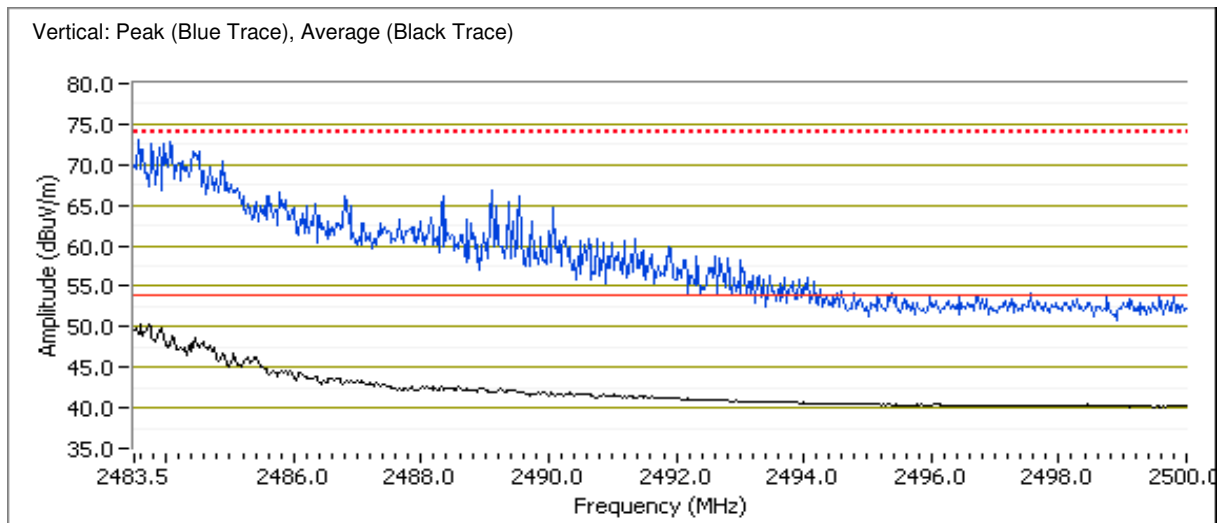

Client: Xirrus	Job Number: J71456
Model: XN16 and XN8	T-Log Number: T71641
	Account Manager: Susan Pezli
Contact: Steve Smith	
Standard: FCC 15.247 / RSS 210	Class: N/A

Run #5: Band-Edge Radiated Spurious Emissions. Operating Mode: 802.11n (20MHz bandwidth), All Chains Active

Date of Test: 5/21/2008	Config. Used: 1
Test Engineer: Mehran Birgani	Config Change: None
Test Location: SVOATS #1	EUT Voltage: POE

Run #5a: 802.11n (20MHz bandwidth), All Chains Active @ 2412 MHz with power setting of 13.0dBm.

Fundamental Signal Field Strength

Frequency MHz	Level dB μ V/m	Pol V/H	15.209 / 15.247		Detector Pk/QP/Avg	Azimuth degrees	Height meters	Comments
			Limit	Margin				
2416.670	98.8	V	-	-	AVG	232	1.0	RB 1.000 MHz; VB: 10 Hz
2418.300	108.4	V	-	-	PK	232	1.0	RB 1.000 MHz; VB: 1.000 MHz
2411.500	93.5	H	-	-	AVG	219	1.3	RB 1.000 MHz; VB: 10 Hz
2415.100	102.9	H	-	-	PK	219	1.3	RB 1.000 MHz; VB: 1.000 MHz

	V	H
Fundamental emission level @ 3m in 100kHz RBW:	99.1	94.5
Limit for emissions outside of restricted bands:	69.1 dB μ V/m	

Limit is -30dBc (UNII power measurement)

Band Edge Signal Field Strength

Frequency MHz	Level dB μ V/m	Pol V/H	15.209 / 15.247		Detector Pk/QP/Avg	Azimuth degrees	Height meters	Comments
			Limit	Margin				
2389.870	53.8	V	54.0	-0.2	AVG	232	1.0	RB 1.000 MHz; VB: 10 Hz
2387.930	71.3	V	74.0	-2.7	PK	232	1.0	RB 1.000 MHz; VB: 1.000 MHz

Note 1: The restricted band edge is at 2390 MHz. For emissions in restricted bands, the limit of 15.209 was used. For all other emissions, the limit was set 30dB below the level of the fundamental and measured in 100kHz.

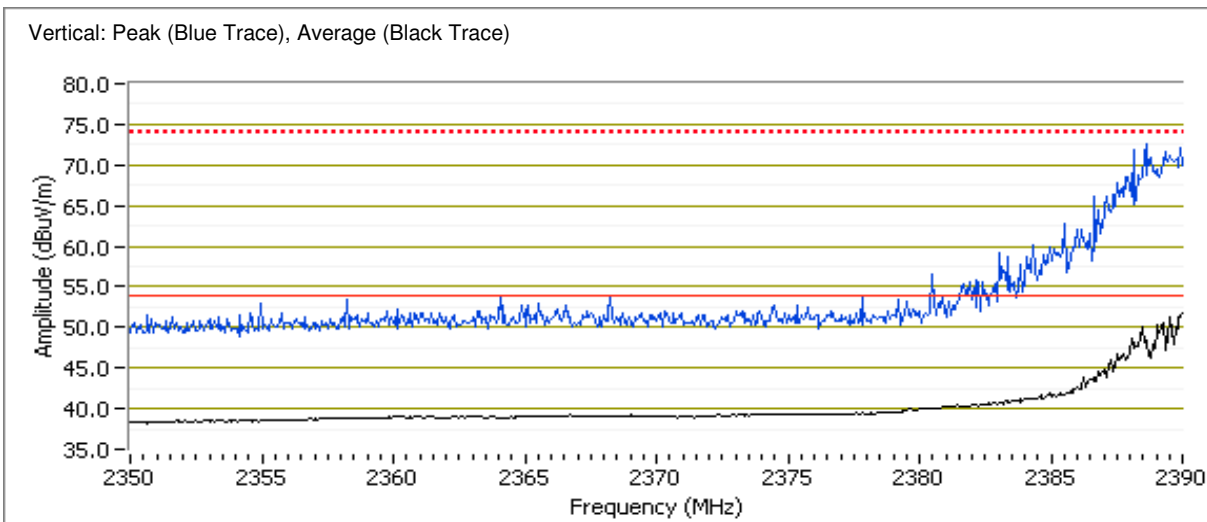

Client: Xirrus	Job Number: J71456
Model: XN16 and XN8	T-Log Number: T71641
	Account Manager: Susan Pezli
Contact: Steve Smith	
Standard: FCC 15.247 / RSS 210	Class: N/A

Run #5b: 802.11n (20MHz bandwidth), All Chains Active @ 2462 MHz with power setting of 9.5dBm.

Fundamental Signal Field Strength

Frequency MHz	Level dB μ V/m	Pol V/H	15.209 / 15.247		Detector Pk/QP/Avg	Azimuth degrees	Height meters	Comments
			Limit	Margin				
2460.900	96.9	V	-	-	AVG	221	1.3	RB 1.000 MHz; VB: 10 Hz
2460.970	106.6	V	-	-	PK	221	1.3	RB 1.000 MHz; VB: 1.000 MHz
2454.970	91.8	H	-	-	AVG	226	1.3	RB 1.000 MHz; VB: 10 Hz
2458.170	100.8	H	-	-	PK	226	1.3	RB 1.000 MHz; VB: 1.000 MHz

	V	H
Fundamental emission level @ 3m in 100kHz RBW:	99.2	92.6
Limit for emissions outside of restricted bands:	69.2 dB μ V/m	

Limit is -30dBc (UNII power measurement)

Band Edge Signal Field Strength

Frequency MHz	Level dB μ V/m	Pol V/H	15.209 / 15.247		Detector Pk/QP/Avg	Azimuth degrees	Height meters	Comments
			Limit	Margin				
2483.720	52.1	V	54.0	-1.9	AVG	221	1.3	RB 1.000 MHz; VB: 10 Hz
2484.190	71.1	V	74.0	-2.9	PK	221	1.3	RB 1.000 MHz; VB: 1.000 MHz

Note 1: The restricted band edge is at 2483.5 MHz. For emissions in restricted bands, the limit of 15.209 was used. For all other emissions, the limit was set 30dB below the level of the fundamental and measured in 100kHz.

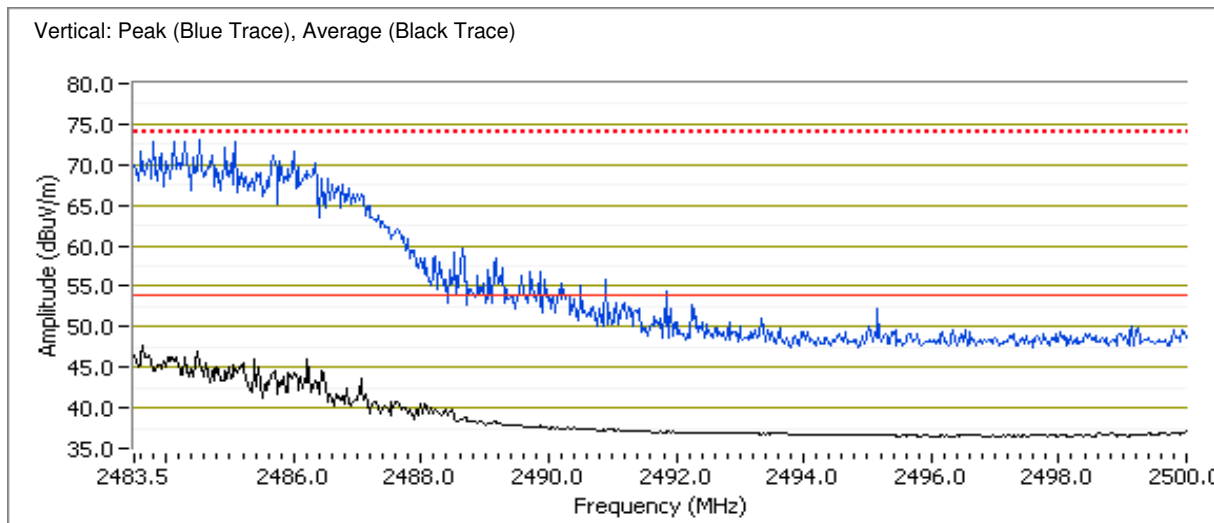

Client: Xirrus	Job Number: J71456
Model: XN16 and XN8	T-Log Number: T71641
	Account Manager: Susan Pezli
Contact: Steve Smith	
Standard: FCC 15.247 / RSS 210	Class: N/A

Run #6: Band-Edge Radiated Spurious Emissions. Operating Mode: 802.11n (40MHz bandwidth), All Chains Active

Date of Test: 5/21/2008	Config. Used: 1
Test Engineer: Mehran Birgani	Config Change: None
Test Location: SVOATS #1	EUT Voltage: POE

Run #6a: 802.11n (40MHz bandwidth), All Chains Active @ 2422 MHz with power setting of 8.0dBm.

Fundamental Signal Field Strength

Frequency MHz	Level dB μ V/m	Pol V/H	15.209 / 15.247		Detector PK/QP/Avg	Azimuth degrees	Height meters	Comments
			Limit	Margin				
2422.270	95.6	V	-	-	AVG	229	1.0	RB 1.000 MHz; VB: 10 Hz
2426.330	103.4	V	-	-	PK	229	1.0	RB 1.000 MHz; VB: 1.000 MHz
2422.400	90.7	H	-	-	AVG	217	1.0	RB 1.000 MHz; VB: 10 Hz
2428.800	96.9	H	-	-	PK	217	1.0	RB 1.000 MHz; VB: 1.000 MHz

	V	H
Fundamental emission level @ 3m in 100kHz RBW:	97.3	92.4
Limit for emissions outside of restricted bands:	67.3 dB μ V/m	

Limit is -30dBc (UNII power measurement)

Band Edge Signal Field Strength

Frequency MHz	Level dB μ V/m	Pol V/H	15.209 / 15.247		Detector PK/QP/Avg	Azimuth degrees	Height meters	Comments
			Limit	Margin				
2389.730	53.6	V	54.0	-0.4	AVG	229	1.0	00 MHz; VB: 10 Hz
2387.330	71.3	V	74.0	-2.7	PK	229	1.0	MHz; VB: 1.000 MHz

Note 1: The restricted band edge is at 2390 MHz. For emissions in restricted bands, the limit of 15.209 was used. For all other emissions, the limit was set 30dB below the level of the fundamental and measured in 100kHz.

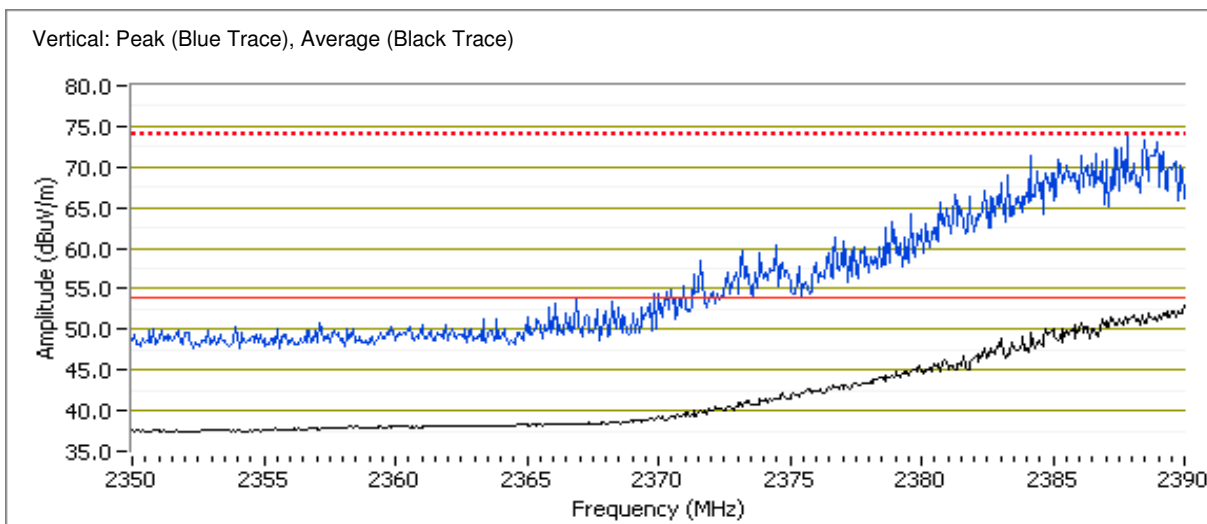

Client: Xirrus	Job Number: J71456
Model: XN16 and XN8	T-Log Number: T71641
Contact: Steve Smith	Account Manager: Susan Pezli
Standard: FCC 15.247 / RSS 210	Class: N/A

Run #6b: 802.11n (40MHz bandwidth), All Chains Active @ 2452 MHz with power setting of 9.0dBm.

Fundamental Signal Field Strength

Frequency MHz	Level dB μ V/m	Pol V/H	15.209 / 15.247		Detector Pk/QP/Avg	Azimuth degrees	Height meters	Comments
			Limit	Margin				
2452.270	92.4	V	-	-	AVG	229	1.2	RB 1.000 MHz; VB: 10 Hz
2440.000	103.4	V	-	-	PK	229	1.2	RB 1.000 MHz; VB: 1.000 MHz
2441.330	85.6	H	-	-	AVG	270	1.0	RB 1.000 MHz; VB: 10 Hz
2443.530	96.5	H	-	-	PK	270	1.0	RB 1.000 MHz; VB: 1.000 MHz

	V	H
Fundamental emission level @ 3m in 100kHz RBW:	97.0	89.3
Limit for emissions outside of restricted bands:	67.0 dB μ V/m	

Limit is -30dBc (UNII power measurement)

Band Edge Signal Field Strength

Frequency MHz	Level dB μ V/m	Pol V/H	15.209 / 15.247		Detector Pk/QP/Avg	Azimuth degrees	Height meters	Comments
			Limit	Margin				
2483.610	53.5	V	54.0	-0.5	AVG	229	1.2	RB 1.000 MHz; VB: 10 Hz
2485.810	69.7	V	74.0	-4.3	PK	229	1.2	RB 1.000 MHz; VB: 1.000 MHz

Note 1: The restricted band edge is at 2483.5 MHz. For emissions in restricted bands, the limit of 15.209 was used. For all other emissions, the limit was set 30dB below the level of the fundamental and measured in 100kHz.

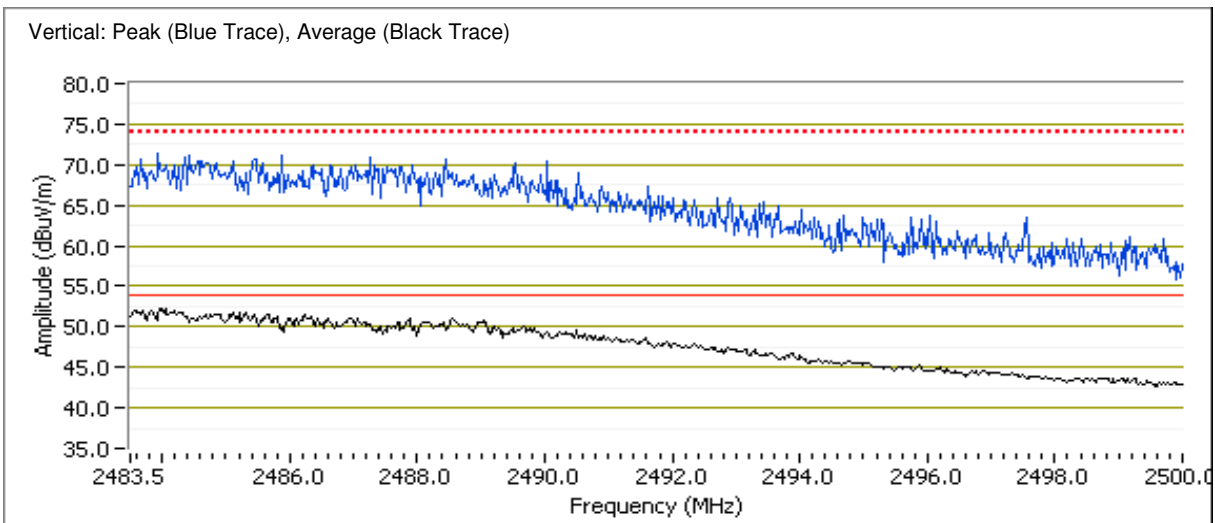

Client: Xirrus	Job Number: J71456
Model: XN16 and XN8	T-Log Number: T71641
	Account Manager: Susan Pelzi
Contact: Steve Smith	
Standard: FCC 15.247 / RSS 210	Class: N/A

RSS 210 and FCC 15.247 (DTS) Radiated Spurious Emissions, Internal Antenna

Test Specific Details

Objective: The objective of this test session is to perform final qualification testing of the EUT with respect to the specification listed above.

General Test Configuration

The EUT and all local support equipment were located on the turntable for radiated spurious emissions testing. All remote support equipment was located approximately 30 meters from the EUT with all I/O connections running on top of the groundplane or routed in overhead in the GR-1089 test configuration.

For radiated emissions testing the measurement antenna was located 3 meters from the EUT.

Ambient Conditions:

Temperature:	22 - 30 °C
Rel. Humidity:	29 - 35 %

Modifications Made During Testing

No modifications were made to the EUT during testing

Deviations From The Standard

No deviations were made from the requirements of the standard.

Client: Xirrus	Job Number: J71456
Model: XN16 and XN8	T-Log Number: T71641
	Account Manager: Susan Pezli
Contact: Steve Smith	
Standard: FCC 15.247 / RSS 210	Class: N/A

Summary of Results - Device Operating in the 2400-2483.5 MHz Band

Run #	Mode	Channel	Power Setting	Test Performed	Limit	Result / Margin
1a	802.11b Single Chain	2412	20	Radiated Emissions 1 - 26 GHz	FCC Part 15.209 / 15.247 (c)	34.4dB μ V/m (52.5 μ V/m) @ 7237.3MHz (-19.6dB)
1b		2437	20	Radiated Emissions 1 - 26 GHz	FCC Part 15.209 / 15.247 (c)	34.8dB μ V/m (55.0 μ V/m) @ 7312.4MHz (-19.2dB)
1c		2462	20	Radiated Emissions 1 - 26 GHz	FCC Part 15.209 / 15.247 (c)	41.6dB μ V/m (120.2 μ V/m) @ 4924.0MHz (-12.4dB)
2a	802.11g Single Chain	2412	20	Radiated Emissions 1 - 26 GHz	FCC Part 15.209 / 15.247 (c)	35.6dB μ V/m (60.3 μ V/m) @ 7236.8MHz (-18.4dB)
2b		2437	20	Radiated Emissions 1 - 26 GHz	FCC Part 15.209 / 15.247 (c)	34.5dB μ V/m (53.1 μ V/m) @ 7312.4MHz (-19.5dB)
2c		2462	20	Radiated Emissions 1 - 26 GHz	FCC Part 15.209 / 15.247 (c)	35.1dB μ V/m (56.9 μ V/m) @ 4923.8MHz (-18.9dB)
3a	802.11n20 All Chains	2412	20	Radiated Emissions 1 - 26 GHz	FCC Part 15.209 / 15.247 (c)	48.6dB μ V/m (269.2 μ V/m) @ 4823.2MHz (-5.4dB)
3b		2437	20	Radiated Emissions 1 - 26 GHz	FCC Part 15.209 / 15.247 (c)	50.2dB μ V/m (323.6 μ V/m) @ 7314.2MHz (-3.8dB)
3c		2462	20	Radiated Emissions 1 - 26 GHz	FCC Part 15.209 / 15.247 (c)	49.0dB μ V/m (281.8 μ V/m) @ 7390.2MHz (-5.0dB)
4a	802.11n40 All Chains	2422	20	Radiated Emissions 1 - 26 GHz	FCC Part 15.209 / 15.247 (c)	50.8dBμV/m (346.7μV/m) @ 7266.3MHz (-3.2dB)
4b		2452	20	Radiated Emissions 1 - 26 GHz	FCC Part 15.209 / 15.247 (c)	49.1dB μ V/m (285.1 μ V/m) @ 7353.4MHz (-4.9dB)
5a	802.11b All Chains (A+B+C)	2412	17.5	Radiated Emissions 1 - 26 GHz	FCC Part 15.209 / 15.247 (c)	49.8dB μ V/m @ 4824.1MHz (-4.2dB)
5b		2437	20.0	Radiated Emissions 1 - 26 GHz	FCC Part 15.209 / 15.247 (c)	52.0dBμV/m @ 4874.2MHz (-2.0dB)
5c		2462	17.5	Radiated Emissions 1 - 26 GHz	FCC Part 15.209 / 15.247 (c)	44.6dB μ V/m @ 4923.9MHz (-9.4dB)

Client: Xirrus	Job Number: J71456
Model: XN16 and XN8	T-Log Number: T71641
	Account Manager: Susan Pezli
Contact: Steve Smith	
Standard: FCC 15.247 / RSS 210	Class: N/A

Run #1: Radiated Spurious Emissions, 1 - 26GHz. 802.11b

Date of Test: 5/14/2008	Config. Used: 1
Test Engineer: Mehran Birgani	Config Change: None
Test Location: SVOATS #1	EUT Voltage: POE

Run #1a: 802.11b, 2412 MHz (Low channel), All Chains Active and set to 20dBm power level

	V	H	
Fundamental emission level @ 3m in 100kHz RBW:	104.4	97.2	
Limit for emissions outside of restricted bands:	74.4 dB μ V/m		Limit is -30dBc (UNII power measurement)

Spurious Emissions

Frequency MHz	Level dB μ V/m	Pol V/H	15.209 / 15.247		Detector Pk/QP/Avg	Azimuth degrees	Height meters	Comments
			Limit	Margin				
4824.130	31.6	V	54.0	-22.4	AVG	129	1.0	RB 1.000 MHz; VB: 10 Hz
4827.160	31.4	H	54.0	-22.6	AVG	5	1.0	RB 1.000 MHz; VB: 10 Hz
7237.330	34.4	V	54.0	-19.6	AVG	180	1.0	Note 2, RB 1 MHz; VB: 10 Hz
7239.810	34.3	H	54.0	-19.7	AVG	50	1.0	Note 2, RB 1 MHz; VB: 10 Hz
4822.080	42.4	H	74.0	-31.6	PK	5	1.0	RB 1.000 MHz; VB: 1.000 MHz
4823.900	42.4	V	74.0	-31.6	PK	129	1.0	RB 1.000 MHz; VB: 1.000 MHz
7235.790	46.1	V	74.0	-27.9	PK	180	1.0	Note 2, RB 1 MHz; VB: 1 MHz
7238.370	46.4	H	74.0	-27.6	PK	50	1.0	Note 2, RB 1 MHz; VB: 1 MHz

Note 1:	For emissions in restricted bands, the limit of 15.209 was used. For all other emissions, the limit was set 30dB below the level of the fundamental and measured in 100kHz.
Note 2:	Signal is not in a restricted band but more stringent limit (15.209) was used.



EMC Test Data

Client: Xirrus	Job Number: J71456
Model: XN16 and XN8	T-Log Number: T71641
	Account Manager: Susan Pezli
Contact: Steve Smith	
Standard: FCC 15.247 / RSS 210	Class: N/A

Run #1b: 802.11b, 2437 MHz (Center channel), All Chains Active and set to 20dBm power level

Spurious Emissions

Frequency MHz	Level dBµV/m	Pol V/H	15.209 / 15.247		Detector Pk/QP/Avg	Azimuth degrees	Height meters	Comments
			Limit	Margin				
4874.020	34.6	V	54.0	-19.4	AVG	58	1.2	RB 1.000 MHz; VB: 10 Hz
4876.180	31.3	H	54.0	-22.7	AVG	360	1.0	RB 1.000 MHz; VB: 10 Hz
7312.370	34.8	V	54.0	-19.2	AVG	166	1.6	RB 1.000 MHz; VB: 10 Hz
7312.490	34.3	H	54.0	-19.7	AVG	10	1.0	RB 1.000 MHz; VB: 10 Hz
4872.600	42.4	H	74.0	-31.6	PK	360	1.0	RB 1.000 MHz; VB: 1.000 MHz
4874.180	43.0	V	74.0	-31.0	PK	58	1.2	RB 1.000 MHz; VB: 1.000 MHz
7310.520	45.9	V	74.0	-28.1	PK	166	1.6	RB 1.000 MHz; VB: 1.000 MHz
7310.700	45.2	H	74.0	-28.8	PK	10	1.0	RB 1.000 MHz; VB: 1.000 MHz

Note 1: For emissions in restricted bands, the limit of 15.209 was used. For all other emissions, the limit was set 30dB below the level of the fundamental and measured in 100kHz.

Run #1c: 802.11b, 2462 MHz (High channel), All Chains Active and set to 20dBm power level

Spurious Emissions

Frequency MHz	Level dBµV/m	Pol V/H	15.209 / 15.247		Detector Pk/QP/Avg	Azimuth degrees	Height meters	Comments
			Limit	Margin				
4924.020	41.6	V	54.0	-12.4	AVG	52	1.4	RB 1.000 MHz; VB: 10 Hz
4924.170	35.6	H	54.0	-18.4	AVG	191	1.0	RB 1.000 MHz; VB: 10 Hz
7387.430	34.6	V	54.0	-19.4	AVG	200	1.0	RB 1.000 MHz; VB: 10 Hz
7390.380	34.2	H	54.0	-19.8	AVG	203	1.0	RB 1.000 MHz; VB: 10 Hz
4924.200	47.8	V	74.0	-26.2	PK	52	1.4	RB 1.000 MHz; VB: 1.000 MHz
4924.280	44.6	H	74.0	-29.4	PK	191	1.0	RB 1.000 MHz; VB: 1.000 MHz
7381.230	46.0	H	74.0	-28.0	PK	203	1.0	RB 1.000 MHz; VB: 1.000 MHz
7387.270	45.7	V	74.0	-28.3	PK	200	1.0	RB 1.000 MHz; VB: 1.000 MHz

Note 1: For emissions in restricted bands, the limit of 15.209 was used. For all other emissions, the limit was set 30dB below the level of the fundamental and measured in 100kHz.



EMC Test Data

Client: Xirrus	Job Number: J71456
Model: XN16 and XN8	T-Log Number: T71641
	Account Manager: Susan Pezli
Contact: Steve Smith	
Standard: FCC 15.247 / RSS 210	Class: N/A

Run #2: Radiated Spurious Emissions, 1 - 26GHz. 802.11g

Date of Test: 5/14/2008 Config. Used: 1
Test Engineer: Mehran Birgani Config Change: None
Test Location: SVOATS #1 EUT Voltage: POE

Run #2a: 802.11g, 2412 MHz (Low channel), All Chains Active and set to 20dBm power level

	V	H	
Fundamental emission level @ 3m in 100kHz RBW:	100.3	95.0	
Limit for emissions outside of restricted bands:	70.3 dB μ V/m		Limit is -30dBc (UNII power measurement)

Spurious Emissions

Frequency MHz	Level dB μ V/m	Pol V/H	15.209 / 15.247		Detector Pk/QP/Avg	Azimuth degrees	Height meters	Comments
			Limit	Margin				
4824.900	30.7	V	54.0	-23.3	AVG	0	1.0	RB 1.000 MHz; VB: 10 Hz
4827.170	30.6	H	54.0	-23.4	AVG	0	1.0	RB 1.000 MHz; VB: 10 Hz
7236.790	35.6	V	54.0	-18.4	AVG	169	2.0	Note 2, RB 1 MHz; VB: 10 Hz
7239.850	34.2	H	54.0	-19.8	AVG	68	1.0	Note 2, RB 1 MHz; VB: 10 Hz
4822.790	42.7	V	74.0	-31.3	PK	0	1.0	RB 1.000 MHz; VB: 1.000 MHz
4823.080	42.0	H	74.0	-32.0	PK	0	1.0	RB 1.000 MHz; VB: 1.000 MHz
7237.360	46.8	V	74.0	-27.2	PK	169	2.0	Note 2, RB 1 MHz; VB: 1 MHz
7238.470	46.2	H	74.0	-27.8	PK	68	1.0	Note 2, RB 1 MHz; VB: 1 MHz

Note 1:	For emissions in restricted bands, the limit of 15.209 was used. For all other emissions, the limit was set 30dB below the level of the fundamental and measured in 100kHz.
Note 2:	Signal is not in a restricted band but more stringent limit (15.209) was used.



EMC Test Data

Client: Xirrus	Job Number: J71456
Model: XN16 and XN8	T-Log Number: T71641
	Account Manager: Susan Pezli
Contact: Steve Smith	
Standard: FCC 15.247 / RSS 210	Class: N/A

Run #2b: 802.11g, 2437 MHz (Center channel), All Chains Active and set to 20dBm power level

Spurious Emissions

Frequency MHz	Level dBµV/m	Pol V/H	15.209 / 15.247		Detector Pk/QP/Avg	Azimuth degrees	Height meters	Comments
			Limit	Margin				
4874.960	32.0	V	54.0	-22.0	AVG	142	1.8	RB 1.000 MHz; VB: 10 Hz
4877.750	31.4	H	54.0	-22.6	AVG	360	1.0	RB 1.000 MHz; VB: 10 Hz
7312.400	34.5	V	54.0	-19.5	AVG	312	1.0	RB 1.000 MHz; VB: 10 Hz
7312.450	34.3	H	54.0	-19.7	AVG	350	1.0	RB 1.000 MHz; VB: 10 Hz
4874.300	42.7	H	74.0	-31.3	PK	360	1.0	RB 1.000 MHz; VB: 1.000 MHz
4875.210	43.0	V	74.0	-31.0	PK	142	1.8	RB 1.000 MHz; VB: 1.000 MHz
7310.690	45.3	V	74.0	-28.7	PK	312	1.0	RB 1.000 MHz; VB: 1.000 MHz
7312.010	45.2	H	74.0	-28.8	PK	350	1.0	RB 1.000 MHz; VB: 1.000 MHz

Note 1: For emissions in restricted bands, the limit of 15.209 was used. For all other emissions, the limit was set 30dB below the level of the fundamental and measured in 100kHz.

Run #2c: 802.11g, 2462 MHz (High channel), Single Chain Active and set to 20dBm power level

Spurious Emissions

Frequency MHz	Level dBµV/m	Pol V/H	15.209 / 15.247		Detector Pk/QP/Avg	Azimuth degrees	Height meters	Comments
			Limit	Margin				
4923.770	35.1	V	54.0	-18.9	AVG	46	1.3	RB 1.000 MHz; VB: 10 Hz
4924.350	32.6	H	54.0	-21.4	AVG	187	1.0	RB 1.000 MHz; VB: 10 Hz
7387.220	34.7	V	54.0	-19.3	AVG	15	1.0	RB 1.000 MHz; VB: 10 Hz
7390.970	34.1	H	54.0	-19.9	AVG	348	1.0	RB 1.000 MHz; VB: 10 Hz
4925.460	46.5	V	74.0	-27.5	PK	46	1.3	RB 1.000 MHz; VB: 1.000 MHz
4926.980	44.0	H	74.0	-30.0	PK	187	1.0	RB 1.000 MHz; VB: 1.000 MHz
7383.770	45.2	H	74.0	-28.8	PK	348	1.0	RB 1.000 MHz; VB: 1.000 MHz
7387.060	46.2	V	74.0	-27.8	PK	15	1.0	RB 1.000 MHz; VB: 1.000 MHz

Note 1: For emissions in restricted bands, the limit of 15.209 was used. For all other emissions, the limit was set 30dB below the level of the fundamental and measured in 100kHz.

Client: Xirrus	Job Number: J71456
Model: XN16 and XN8	T-Log Number: T71641
	Account Manager: Susan Pezli
Contact: Steve Smith	
Standard: FCC 15.247 / RSS 210	Class: N/A

Run #3: Radiated Spurious Emissions, 1 - 26GHz. 802.11n (20MHz)

Date of Test: 5/21/2008	Config. Used: 1
Test Engineer: Mehran Birgani	Config Change: None
Test Location: SVOATS #1	EUT Voltage: POE

Run #3a: 802.11n (20MHz), 2412 MHz (Low channel), All Chains Active and set to 20dBm power level

	V	H	
Fundamental emission level @ 3m in 100kHz RBW:	99.1	94.5	
Limit for emissions outside of restricted bands:	69.1 dB μ V/m		Limit is -30dBc (UNII power measurement)

Spurious Emissions

Frequency MHz	Level dB μ V/m	Pol V/H	15.209 / 15.247		Detector Pk/QP/Avg	Azimuth degrees	Height meters	Comments
			Limit	Margin				
7232.970	38.5	V	54.0	-15.5	AVG	203	1.9	Note 2, RB 1 MHz; VB: 10 Hz
4823.220	48.6	V	54.0	-5.4	PK	269	2.0	Peak reading with average limit
4827.630	41.9	H	54.0	-12.1	PK	202	1.4	Peak reading with average limit
7231.220	47.1	H	54.0	-6.9	PK	180	2.2	Peak reading with average limit
7236.020	51.6	V	74.0	-22.4	PK	203	1.9	Note 2, RB 1 MHz; VB: 1 MHz

Note 1:	For emissions in restricted bands, the limit of 15.209 was used. For all other emissions, the limit was set 30dB below the level of the fundamental and measured in 100kHz.
Note 2:	Signal is not in a restricted band but more stringent limit (15.209) was used.

Run #3b: 802.11n (20MHz), 2437 MHz (Center channel), All Chains Active and set to 20dBm power level
Spurious Emissions

Frequency MHz	Level dB μ V/m	Pol V/H	15.209 / 15.247		Detector Pk/QP/Avg	Azimuth degrees	Height meters	Comments
			Limit	Margin				
7309.030	40.6	V	54.0	-13.4	AVG	266	1.9	RB 1.000 MHz; VB: 10 Hz
4869.800	42.0	H	74.0	-32.0	PK	198	2.2	Peak reading with average limit
4876.550	46.5	V	54.0	-7.5	PK	192	2.3	Peak reading with average limit
7308.120	53.2	V	74.0	-20.8	PK	266	1.9	RB 1.000 MHz; VB: 1.000 MHz
7314.170	50.2	H	54.0	-3.8	PK	208	1.9	Peak reading with average limit

Note 1:	For emissions in restricted bands, the limit of 15.209 was used. For all other emissions, the limit was set 30dB below the level of the fundamental and measured in 100kHz.
---------	---

Client: Xirrus	Job Number: J71456
Model: XN16 and XN8	T-Log Number: T71641
Contact: Steve Smith	Account Manager: Susan Pezl
Standard: FCC 15.247 / RSS 210	Class: N/A

Run #3c: 802.11n (20MHz), 2462 MHz (High channel), All Chains Active and set to 20dBm power level
Spurious Emissions

Frequency MHz	Level dB μ V/m	Pol V/H	15.209 / 15.247		Detector Pk/QP/Avg	Azimuth degrees	Height meters	Comments
			Limit	Margin				
7388.870	39.4	V	54.0	-14.6	AVG	271	2.1	RB 1.000 MHz; VB: 10 Hz
4926.200	47.4	V	54.0	-6.6	PK	196	2.4	Peak reading with average limit
4926.280	44.1	H	54.0	-9.9	PK	200	1.4	Peak reading with average limit
7388.070	53.1	V	74.0	-20.9	PK	271	2.1	RB 1.000 MHz; VB: 1.000 MHz
7390.200	49.0	H	54.0	-5.0	PK	207	1.9	Peak reading with average limit

Note 1:	For emissions in restricted bands, the limit of 15.209 was used. For all other emissions, the limit was set 30dB below the level of the fundamental and measured in 100kHz.
---------	---

Run #4: Radiated Spurious Emissions, 1 - 26GHz. 802.11n (40MHz)

Date of Test: 5/21/2008
 Test Engineer: Mehran Birgani
 Test Location: SVOATS #1

Config. Used: 1
 Config Change: None
 EUT Voltage: POE

Run #4a: 802.11n (40MHz), 2422 MHz (Low channel), All Chains Active and set to 20dBm power level
Spurious Emissions

Frequency MHz	Level dB μ V/m	Pol V/H	15.209 / 15.247		Detector Pk/QP/Avg	Azimuth degrees	Height meters	Comments
			Limit	Margin				
4839.000	46.5	V	54.0	-7.5	PK	277	2.0	Peak reading with average limit
4842.380	41.7	H	54.0	-12.3	PK	222	2.0	Peak reading with average limit
7262.500	46.4	H	54.0	-7.6	PK	270	1.9	Peak reading with average limit
7266.330	50.8	V	54.0	-3.2	PK	205	2.4	Peak reading with average limit

Note 1:	For emissions in restricted bands, the limit of 15.209 was used. For all other emissions, the limit was set 30dB below the level of the fundamental and measured in 100kHz.
---------	---

Run #4b: 802.11n (40MHz), 2452 MHz (High channel), All Chains Active and set to 20dBm power level
Spurious Emissions

Frequency MHz	Level dB μ V/m	Pol V/H	15.209 / 15.247		Detector Pk/QP/Avg	Azimuth degrees	Height meters	Comments
			Limit	Margin				
4899.730	41.5	H	54.0	-12.5	PK	295	1.0	Peak reading with average limit
4901.550	44.1	V	54.0	-9.9	PK	192	2.2	Peak reading with average limit
7353.370	49.1	V	54.0	-4.9	PK	188	2.1	Peak reading with average limit
7358.150	47.9	H	54.0	-6.1	PK	206	1.8	Peak reading with average limit

Note 1:	For emissions in restricted bands, the limit of 15.209 was used. For all other emissions, the limit was set 30dB below the level of the fundamental and measured in 100kHz.
---------	---

Client: Xirrus	Job Number: J71456
Model: XN16 and XN8	T-Log Number: T71641
	Account Manager: Susan Pezli
Contact: Steve Smith	
Standard: FCC 15.247 / RSS 210	Class: N/A

Run # 5: Radiated Spurious Emissions, 1 - 26GHz. 802.11b

Date of Test: 5/29/2008
 Test Engineer: Suhaila Khushzad
 Test Location: SVOATS #1

Config. Used: 1
 Config Change: None
 EUT Voltage: POE

Run # 5a: 802.11b, 2412 MHz (Low channel), All Chains Active, Power Setting: 17.5 dBm
Spurious Emissions

Frequency MHz	Level dBµV/m	Pol V/H	15.209 / 15.247		Detector Pk/QP/Avg	Azimuth degrees	Height meters	Comments
			Limit	Margin				
4824.080	49.8	V	54.0	-4.2	AVG	283	2.1	
9648.170	46.4	V	54.0	-7.6	AVG	351	2.2	
9648.250	46.3	H	54.0	-7.7	AVG	229	1.8	
7211.250	35.8	V	54.0	-18.2	AVG	96	1.0	
7212.000	35.7	H	54.0	-18.3	AVG	88	2.1	
4824.250	34.3	H	54.0	-19.7	AVG	234	1.1	
9648.170	52.8	V	74.0	-21.2	PK	351	2.2	
4824.080	52.5	V	74.0	-21.5	PK	283	2.1	
9648.250	52.3	H	74.0	-21.7	PK	229	1.8	
7212.000	47.2	H	74.0	-26.8	PK	88	2.1	
7211.250	46.8	V	74.0	-27.2	PK	96	1.0	
4824.250	43.6	H	74.0	-30.4	PK	234	1.1	

Run # 5b: 802.11b, 2437 MHz (Center channel), All Chains Active, Power Setting: 20 dBm
Spurious Emissions

Frequency MHz	Level dBµV/m	Pol V/H	15.209 / 15.247		Detector Pk/QP/Avg	Azimuth degrees	Height meters	Comments
			Limit	Margin				
4874.170	52.0	V	54.0	-2.0	AVG	257	2.3	
7310.500	46.8	V	54.0	-7.2	AVG	295	2.2	
9748.250	45.7	V	54.0	-8.3	AVG	170	2.2	
9748.170	42.7	H	54.0	-11.3	AVG	5	2.5	
7308.420	37.2	H	54.0	-16.8	AVG	283	2.5	
7310.500	56.7	V	74.0	-17.3	PK	295	2.2	
4874.000	36.2	H	54.0	-17.8	AVG	223	1.0	
4874.170	54.3	V	74.0	-19.7	PK	257	2.3	
9748.250	52.6	V	74.0	-21.4	PK	170	2.2	
9748.170	51.1	H	74.0	-22.9	PK	5	2.5	
7308.420	47.6	H	74.0	-26.4	PK	283	2.5	
4874.000	44.9	H	74.0	-29.1	PK	223	1.0	

Note 1:

For emissions in restricted bands, the limit of 15.209 was used. For all other emissions, the limit was set 30dB below the level of the fundamental and measured in 100kHz.



EMC Test Data

Client: Xirrus	Job Number: J71456
Model: XN16 and XN8	T-Log Number: T71641
	Account Manager: Susan Pezli
Contact: Steve Smith	
Standard: FCC 15.247 / RSS 210	Class: N/A

Run # 5c: 802.11b, 2462 MHz (High channel), All Chains Active, Power Setting: 17.5 dBm

Spurious Emissions

Frequency MHz	Level dB μ V/m	Pol V/H	15.209 / 15.247		Detector Pk/QP/Avg	Azimuth degrees	Height meters	Comments
			Limit	Margin				
4923.920	44.6	V	54.0	-9.4	AVG	246	2.2	
9847.920	43.1	H	54.0	-10.9	AVG	254	1.5	
9848.000	41.9	V	54.0	-12.1	AVG	181	2.1	
7363.500	35.6	H	54.0	-18.4	AVG	360	1.9	
7361.750	35.5	V	54.0	-18.5	AVG	105	2.5	
4923.830	33.2	H	54.0	-20.8	AVG	206	1.0	
9848.000	51.8	V	74.0	-22.2	PK	181	2.1	
9847.920	51.5	H	74.0	-22.5	PK	254	1.5	
4923.920	49.2	V	74.0	-24.8	PK	246	2.2	
7363.500	48.1	H	74.0	-25.9	PK	360	1.9	
7361.750	46.5	V	74.0	-27.5	PK	105	2.5	
4923.830	44.5	H	74.0	-29.5	PK	206	1.0	

Note 1: For emissions in restricted bands, the limit of 15.209 was used. For all other emissions, the limit was set 30dB below the level of the fundamental and measured in 100kHz.

Client: Xirrus	Job Number: J71456
Model: XN16 and XN8	T-Log Number: T71641
	Account Manager: Susan PezI
Contact: Steve Smith	
Standard: FCC 15.247 / RSS 210	Class: N/A

RSS 210 and FCC 15.247 (DTS) Radiated Spurious Emissions 2390 MHz and 2483.5 MHz Band Edges - External Antenna

Test Specific Details

Objective: The objective of this test session is to perform final qualification testing of the EUT with respect to the specification listed above.

General Test Configuration

The EUT and all local support equipment were located on the turntable for radiated spurious emissions testing. All remote support equipment was located approximately 30 meters from the EUT with all I/O connections running on top of the groundplane.

For radiated emissions testing the measurement antenna was located 3 meters from the EUT.

Ambient Conditions:	Temperature:	22 °C
	Rel. Humidity:	24 %

Modifications Made During Testing

No modifications were made to the EUT during testing

Deviations From The Standard

No deviations were made from the requirements of the standard.

Summary of Results - Device Operating in the 2400-2483.5 MHz Band

Run #	Mode	Channel	Power Setting	Test Performed	Limit	Result / Margin
1a	802.11b	2412	18.0	Restricted Band Edge (2390 MHz)	FCC Part 15.209 / 15.247(c)	53.7dBµV/m (484.2µV/m) @ 2387.4MHz (-0.3dB)
1b		2462	18.5	Restricted Band Edge (2483.5 MHz)	FCC Part 15.209 / 15.247(c)	53.5dBµV/m (473.2µV/m) @ 2487.9MHz (-0.5dB)
3a	802.11g	2412	14.5	Restricted Band Edge (2390 MHz)	FCC Part 15.209 / 15.247(c)	53.7dBµV/m (484.2µV/m) @ 2390.0MHz (-0.3dB)
3b		2462	13.5	Restricted Band Edge (2483.5 MHz)	FCC Part 15.209 / 15.247(c)	52.4dBµV/m (416.9µV/m) @ 2483.5MHz (-1.6dB)

Client: Xirrus	Job Number: J71456
Model: XN16 and XN8	T-Log Number: T71641
	Account Manager: Susan Pezli
Contact: Steve Smith	
Standard: FCC 15.247 / RSS 210	Class: N/A

Run #1: Band-Edge Radiated Spurious Emissions. Operating Mode: 802.11b

Date of Test: 5/22/2008	Config. Used: 1
Test Engineer: Mehran Birgani	Config Change: None
Test Location: SVOATS #2	EUT Voltage: POE

Run #1a: 802.11b, Single Chain @ 2412 MHz with power setting of 18.0 dBm

Fundamental Signal Field Strength

Frequency MHz	Level dB μ V/m	Pol V/H	15.209 / 15.247		Detector Pk/QP/Avg	Azimuth degrees	Height meters	Comments
			Limit	Margin				
2413.850	102.3	V	-	-	AVG	351	1.0	RB 1.000 MHz; VB: 10 Hz
2413.000	105.4	V	-	-	PK	351	1.0	RB 1.000 MHz; VB: 1.000 MHz
2411.350	95.3	H	-	-	AVG	322	1.0	RB 1.000 MHz; VB: 10 Hz
2413.100	98.0	H	-	-	PK	322	1.0	RB 1.000 MHz; VB: 1.000 MHz

	V	H
Fundamental emission level @ 3m in 100kHz RBW:	102.9	95.4
Limit for emissions outside of restricted bands:	72.9 dB μ V/m	

Limit is -30dBc (UNII power measurement)

Band Edge Signal Field Strength

Frequency MHz	Level dB μ V/m	Pol V/H	15.209 / 15.247		Detector Pk/QP/Avg	Azimuth degrees	Height meters	Comments
			Limit	Margin				
2387.400	53.7	V	54.0	-0.3	AVG	351	1.0	RB 1.000 MHz; VB: 10 Hz
2388.600	60.6	V	74.0	-13.4	PK	351	1.0	RB 1.000 MHz; VB: 1.000 MHz

Note 1: The restricted band edge is at 2390 MHz. For emissions in restricted bands, the limit of 15.209 was used. For all other emissions, the limit was set 30dB below the level of the fundamental and measured in 100kHz.

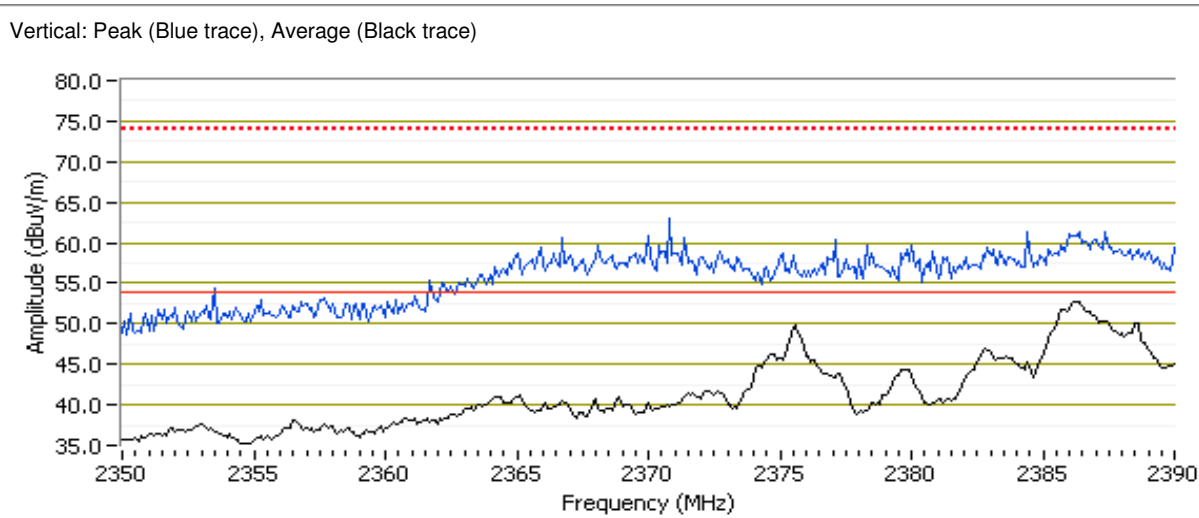

Client: Xirrus	Job Number: J71456
Model: XN16 and XN8	T-Log Number: T71641
	Account Manager: Susan Pezli
Contact: Steve Smith	
Standard: FCC 15.247 / RSS 210	Class: N/A

Run #1b: 802.11b, Single Chain @ 2462 MHz with power setting of 18.5 dBm.
Fundamental Signal Field Strength

Frequency MHz	Level dB μ V/m	Pol V/H	15.209 / 15.247		Detector Pk/QP/Avg	Azimuth degrees	Height meters	Comments
			Limit	Margin				
2463.800	101.6	V	-	-	AVG	345	1.6	RB 1.000 MHz; VB: 10 Hz
2463.100	104.6	V	-	-	PK	345	1.6	RB 1.000 MHz; VB: 1.000 MHz
2462.850	95.9	H	-	-	AVG	328	1.0	RB 1.000 MHz; VB: 10 Hz
2463.100	98.7	H	-	-	PK	328	1.0	RB 1.000 MHz; VB: 1.000 MHz

	V	H
Fundamental emission level @ 3m in 100kHz RBW:	101.2	95.7
Limit for emissions outside of restricted bands:	71.2 dB μ V/m	

Limit is -30dBc (UNII power measurement)

Band Edge Signal Field Strength

Frequency MHz	Level dB μ V/m	Pol V/H	15.209 / 15.247		Detector Pk/QP/Avg	Azimuth degrees	Height meters	Comments
			Limit	Margin				
2487.910	53.5	V	54.0	-0.5	AVG	345	1.6	RB 1.000 MHz; VB: 10 Hz
2483.580	64.6	V	74.0	-9.4	PK	345	1.6	RB 1.000 MHz; VB: 1.000 MHz

Note 1: The restricted band edge is at 2483.5 MHz. For emissions in restricted bands, the limit of 15.209 was used. For all other emissions, the limit was set 30dB below the level of the fundamental and measured in 100kHz.

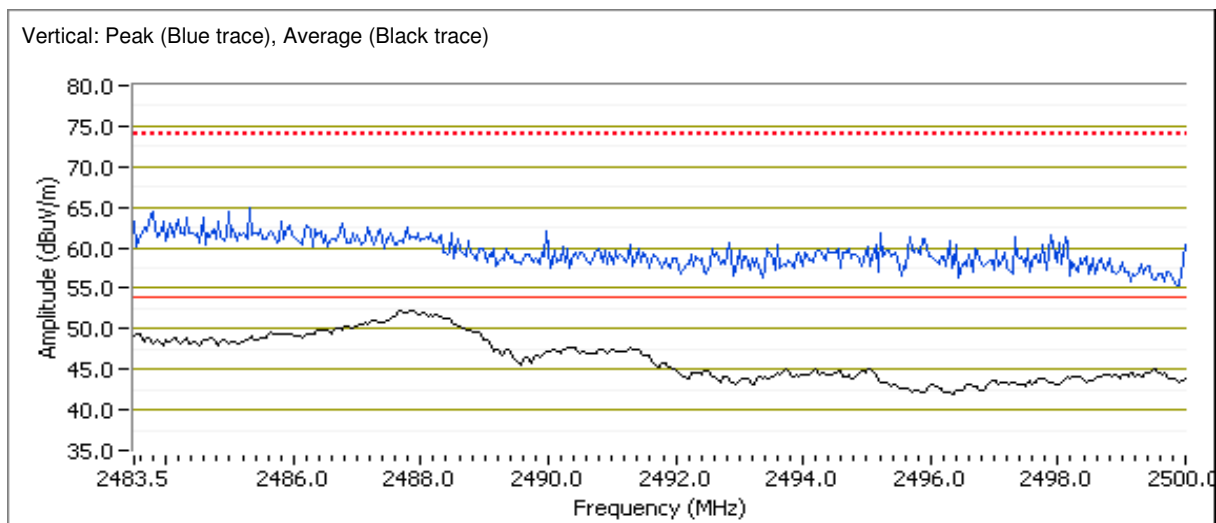

Client: Xirrus	Job Number: J71456
Model: XN16 and XN8	T-Log Number: T71641
	Account Manager: Susan Pezli
Contact: Steve Smith	
Standard: FCC 15.247 / RSS 210	Class: N/A

Run #2: Band-Edge Radiated Spurious Emissions. Operating Mode: 802.11g

Date of Test: 5/22/2008	Config. Used: 1
Test Engineer: Mehran Birgani	Config Change: None
Test Location: SVOATS #2	EUT Voltage: POE

Run #2a: 802.11g, Single Chain @ 2412 MHz with power setting of 14.5 dBm.

Fundamental Signal Field Strength

Frequency MHz	Level dB μ V/m	Pol V/H	15.209 / 15.247		Detector Pk/QP/Avg	Azimuth degrees	Height meters	Comments
			Limit	Margin				
2410.950	95.8	V	-	-	AVG	347	1.0	RB 1.000 MHz; VB: 10 Hz
2412.250	104.0	V	-	-	PK	347	1.0	RB 1.000 MHz; VB: 1.000 MHz
2410.900	88.9	H	-	-	AVG	320	1.0	RB 1.000 MHz; VB: 10 Hz
2411.050	96.8	H	-	-	PK	320	1.0	RB 1.000 MHz; VB: 1.000 MHz

	V	H
Fundamental emission level @ 3m in 100kHz RBW:	94.7	90.1
Limit for emissions outside of restricted bands:	64.7 dB μ V/m	

Limit is -30dBc (UNII power measurement)

Band Edge Signal Field Strength

Frequency MHz	Level dB μ V/m	Pol V/H	15.209 / 15.247		Detector Pk/QP/Avg	Azimuth degrees	Height meters	Comments
			Limit	Margin				
2390.000	53.7	V	54.0	-0.3	AVG	347	1.0	RB 1.000 MHz; VB: 10 Hz
2390.000	66.7	V	74.0	-7.3	PK	347	1.0	RB 1.000 MHz; VB: 1.000 MHz

Note 1: The restricted band edge is at 2390 MHz. For emissions in restricted bands, the limit of 15.209 was used. For all other emissions, the limit was set 30dB below the level of the fundamental and measured in 100kHz.

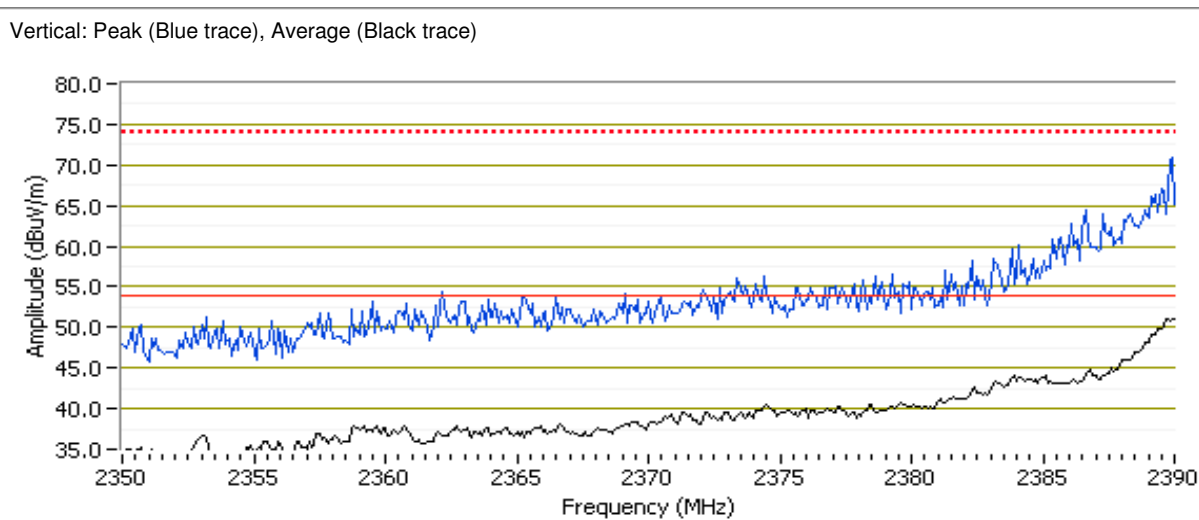

Client: Xirrus	Job Number: J71456
Model: XN16 and XN8	T-Log Number: T71641
Contact: Steve Smith	Account Manager: Susan Pezli
Standard: FCC 15.247 / RSS 210	Class: N/A

Run #2b: 802.11g, Single Chain @ 2462 MHz with power setting of 13.5 dBm.

Fundamental Signal Field Strength

Frequency MHz	Level dB μ V/m	Pol V/H	15.209 / 15.247		Detector Pk/QP/Avg	Azimuth degrees	Height meters	Comments
			Limit	Margin				
2465.900	94.3	V	-	-	AVG	344	1.0	RB 1.000 MHz; VB: 10 Hz
2469.350	102.4	V	-	-	PK	344	1.0	RB 1.000 MHz; VB: 1.000 MHz
2463.150	87.4	H	-	-	AVG	337	1.0	RB 1.000 MHz; VB: 10 Hz
2465.300	95.9	H	-	-	PK	337	1.0	RB 1.000 MHz; VB: 1.000 MHz

	V	H
Fundamental emission level @ 3m in 100kHz RBW:	93.5	86.1
Limit for emissions outside of restricted bands:	63.5 dB μ V/m	

Limit is -30dBc (UNII power measurement)

Band Edge Signal Field Strength

Frequency MHz	Level dB μ V/m	Pol V/H	15.209 / 15.247		Detector Pk/QP/Avg	Azimuth degrees	Height meters	Comments
			Limit	Margin				
2483.540	52.4	V	54.0	-1.6	AVG	344	1.0	RB 1.000 MHz; VB: 10 Hz
2483.620	67.6	V	74.0	-6.4	PK	344	1.0	RB 1.000 MHz; VB: 1.000 MHz

Note 1: The restricted band edge is at 2483.5 MHz. For emissions in restricted bands, the limit of 15.209 was used. For all other emissions, the limit was set 30dB below the level of the fundamental and measured in 100kHz.

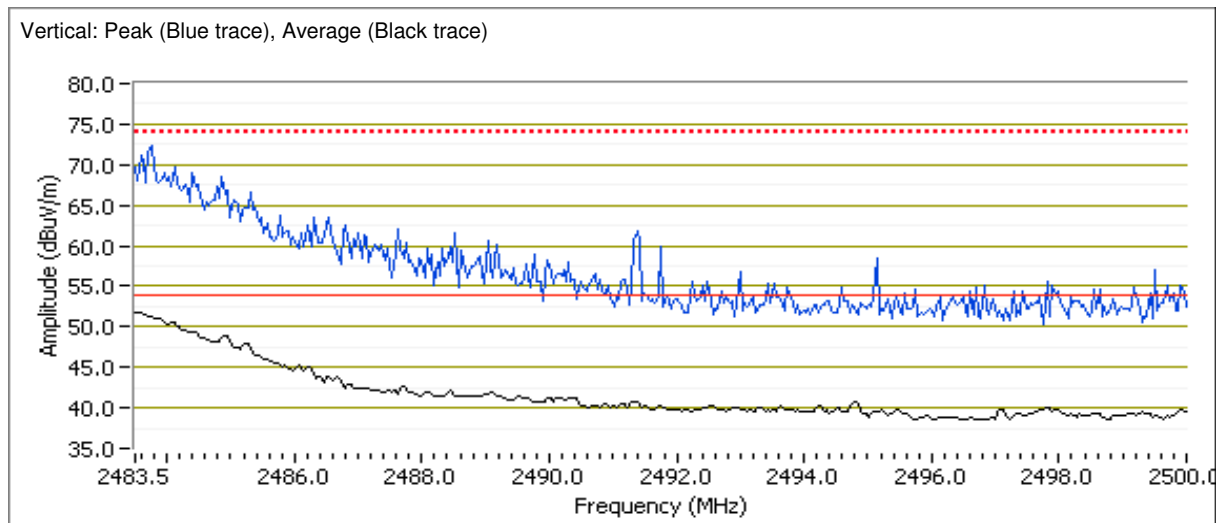

Client: Xirrus	Job Number: J71456
Model: XN16 and XN8	T-Log Number: T71641
	Account Manager: Susan Pezli
Contact: Steve Smith	
Standard: FCC 15.247 / RSS 210	Class: N/A

RSS 210 and FCC 15.247 (DTS) Radiated Spurious Emissions, External Antenna

Test Specific Details

Objective: The objective of this test session is to perform final qualification testing of the EUT with respect to the specification listed above.

General Test Configuration

The EUT and all local support equipment were located on the turntable for radiated spurious emissions testing. All remote support equipment was located approximately 30 meters from the EUT with all I/O connections running on top of the groundplane.

For radiated emissions testing the measurement antenna was located 3 meters from the EUT.

Ambient Conditions:

Temperature: 22 °C
Rel. Humidity: 24 %

Date of Test: 5/22/2008
Test Engineer: Mehran Birgani
Test Location: SVOATS #2

Config. Used: 1
Config Change: None
EUT Voltage: POE

Summary of Results - Device Operating in the 2400-2483.5 MHz Band

Run #	Mode	Channel	Power Setting	Test Performed	Limit	Result / Margin
1a	802.11b	2412	20	Radiated Emissions 1 - 26 GHz	FCC Part 15.209 / 15.247 (c)	44.6dBµV/m (169.8µV/m) @ 4824.0MHz (-9.4dB)
1b		2437	20	Radiated Emissions 1 - 26 GHz	FCC Part 15.209 / 15.247 (c)	48.1dBµV/m (254.1µV/m) @ 7307.7MHz (-5.9dB)
1c		2462	20	Radiated Emissions 1 - 26 GHz	FCC Part 15.209 / 15.247 (c)	49.9dBµV/m (312.6µV/m) @ 7388.9MHz (-4.1dB)
2a	802.11g	2412	20	Radiated Emissions 1 - 26 GHz	FCC Part 15.209 / 15.247 (c)	47.5dBµV/m (237.1µV/m) @ 7237.1MHz (-6.5dB)
2b		2437	20	Radiated Emissions 1 - 26 GHz	FCC Part 15.209 / 15.247 (c)	47.8dBµV/m (245.5µV/m) @ 7311.1MHz (-6.2dB)
2c		2462	20	Radiated Emissions 1 - 26 GHz	FCC Part 15.209 / 15.247 (c)	45.6dBµV/m (190.5µV/m) @ 7386.1MHz (-8.4dB)

Modifications Made During Testing

No modifications were made to the EUT during testing

Deviations From The Standard

No deviations were made from the requirements of the standard.



EMC Test Data

Client: Xirrus	Job Number: J71456
Model: XN16 and XN8	T-Log Number: T71641
	Account Manager: Susan Pezli
Contact: Steve Smith	
Standard: FCC 15.247 / RSS 210	Class: N/A

Run #1: Radiated Spurious Emissions, 1 - 26GHz. 802.11b

Run #1a: 802.11b, 2412 MHz (Low channel), Power set to 20dBm

Spurious Emissions

Frequency MHz	Level dBμV/m	Pol V/H	15.209 / 15.247		Detector Pk/QP/Avg	Azimuth degrees	Height meters	Comments
			Limit	Margin				
4824.040	44.6	V	54.0	-9.4	AVG	34	1.0	RB 1.000 MHz; VB: 10 Hz
4824.090	33.0	H	54.0	-21.0	AVG	24	1.4	RB 1.000 MHz; VB: 10 Hz
7235.020	39.4	V	54.0	-14.6	AVG	251	1.0	Note 2, RB 1 MHz; VB: 10 Hz
4824.000	43.9	H	74.0	-30.1	PK	24	1.4	RB 1.000 MHz; VB: 1.000 MHz
4824.070	48.5	V	74.0	-25.5	PK	34	1.0	RB 1.000 MHz; VB: 1.000 MHz
7231.970	49.2	V	74.0	-24.8	PK	251	1.0	Note 2, RB 1 MHz; VB: 1 MHz

Note 1:	For emissions in restricted bands, the limit of 15.209 was used. For all other emissions, the limit was set 30dB below the level of the fundamental and measured in 100kHz.
Note 2:	Signal is not in a restricted band but more stringent limit (15.209) was used.

Run #1b: 802.11b, 2437 MHz (Center channel), Power set to 20dBm

Spurious Emissions

Frequency MHz	Level dBμV/m	Pol V/H	15.209 / 15.247		Detector Pk/QP/Avg	Azimuth degrees	Height meters	Comments
			Limit	Margin				
4873.970	44.6	V	54.0	-9.4	AVG	7	1.1	RB 1.000 MHz; VB: 10 Hz
4873.970	35.1	H	54.0	-18.9	AVG	21	1.5	RB 1.000 MHz; VB: 10 Hz
4873.900	44.3	H	74.0	-29.7	PK	21	1.5	RB 1.000 MHz; VB: 1.000 MHz
4873.990	48.6	V	74.0	-25.4	PK	7	1.1	RB 1.000 MHz; VB: 1.000 MHz
7307.650	48.1	V	54.0	-5.9	PK	360	1.0	Peak reading with average limit

Note 1:	For emissions in restricted bands, the limit of 15.209 was used. For all other emissions, the limit was set 30dB below the level of the fundamental and measured in 100kHz.
---------	---

Run #1c: 802.11b, 2462 MHz (High channel), Power set to 20dBm

Spurious Emissions

Frequency MHz	Level dBμV/m	Pol V/H	15.209 / 15.247		Detector Pk/QP/Avg	Azimuth degrees	Height meters	Comments
			Limit	Margin				
4923.980	36.6	H	54.0	-17.4	AVG	41	1.3	RB 1.000 MHz; VB: 10 Hz
4924.020	45.9	V	54.0	-8.1	AVG	37	1.3	RB 1.000 MHz; VB: 10 Hz
4923.980	44.6	H	74.0	-29.4	PK	41	1.3	RB 1.000 MHz; VB: 1.000 MHz
4924.070	49.5	V	74.0	-24.5	PK	37	1.3	RB 1.000 MHz; VB: 1.000 MHz
7388.850	49.9	V	54.0	-4.1	PK	1	1.0	Peak reading with average limit

Note 1:	For emissions in restricted bands, the limit of 15.209 was used. For all other emissions, the limit was set 30dB below the level of the fundamental and measured in 100kHz.
---------	---

Client: Xirrus	Job Number: J71456
Model: XN16 and XN8	T-Log Number: T71641
	Account Manager: Susan Pezli
Contact: Steve Smith	
Standard: FCC 15.247 / RSS 210	Class: N/A

Run #2: Radiated Spurious Emissions, 1 - 26GHz. 802.11g
Run #2a: 802.11g, 2412 MHz (Low channel), Power set to 20dBm
Spurious Emissions

Frequency MHz	Level dB μ V/m	Pol V/H	15.209 / 15.247		Detector Pk/QP/Avg	Azimuth degrees	Height meters	Comments
			Limit	Margin				
4823.150	42.1	H	54.0	-11.9	PK	12	1.0	Peak reading with average limit
4825.040	46.7	V	54.0	-7.3	PK	35	1.0	Peak reading with average limit
7237.130	47.5	V	54.0	-6.5	PK	21	1.0	Peak reading with average limit

Note 1:	For emissions in restricted bands, the limit of 15.209 was used. For all other emissions, the limit was set 30dB below the level of the fundamental and measured in 100kHz.
Note 2:	Signal is not in a restricted band but more stringent limit (15.209) was used.

Run #2b: 802.11g, 2437 MHz (Center channel), Power set to 20dBm
Spurious Emissions

Frequency MHz	Level dB μ V/m	Pol V/H	15.209 / 15.247		Detector Pk/QP/Avg	Azimuth degrees	Height meters	Comments
			Limit	Margin				
4869.270	43.3	H	54.0	-10.7	PK	20	1.0	Peak reading with average limit
4875.250	45.3	V	54.0	-8.7	PK	8	1.0	Peak reading with average limit
7311.070	47.8	V	54.0	-6.2	PK	0	1.0	Peak reading with average limit

Note 1:	For emissions in restricted bands, the limit of 15.209 was used. For all other emissions, the limit was set 30dB below the level of the fundamental and measured in 100kHz.
---------	---

Run #2c: 802.11g, 2462 MHz (High channel), Power set to 20dBm
Spurious Emissions

Frequency MHz	Level dB μ V/m	Pol V/H	15.209 / 15.247		Detector Pk/QP/Avg	Azimuth degrees	Height meters	Comments
			Limit	Margin				
4925.150	36.7	V	54.0	-17.3	AVG	9	1.1	RB 1.000 MHz; VB: 10 Hz
4924.550	47.4	V	74.0	-26.6	PK	9	1.1	RB 1.000 MHz; VB: 1.000 MHz
4926.380	42.9	H	54.0	-11.1	PK	7	1.0	Peak reading with average limit
7386.090	45.6	V	54.0	-8.4	PK	5	1.0	Peak reading with average limit

Note 1:	For emissions in restricted bands, the limit of 15.209 was used. For all other emissions, the limit was set 30dB below the level of the fundamental and measured in 100kHz.
---------	---

Client: Xirrus	Job Number: J71456
Model: XN16 and XN8	T-Log Number: T71641
	Account Manager: Susan Pezli
Contact: Steve Smith	
Standard: FCC 15.247 / RSS 210	Class: N/A

RSS 210 and FCC 15.247 (DTS) Radiated Spurious Emissions, Internal Antenna

Test Specific Details

Objective: The objective of this test session is to perform final qualification testing of the EUT with respect to the specification listed above.

Summary of Results - Device Operating in the 5725-5850 MHz Band

Run #	Mode	Channel	Power Setting	Measured Power	Test Performed	Limit	Result / Margin
1a	n20 5745, 5785, 5825 MHz n40 5755, 5795 MHz	5745	17		Radiated Emissions, 1 - 40 GHz	FCC Part 15.209 / 15.247(c)	53.0dBμV/m @ 11576.3MHz (-1.0dB)
		5785	17				
		5825	17				
1b	a & n20 5745, 5785, 5825 MHz n40 5755, 5795 MHz	5745	17		Radiated Emissions, 1 - 40 GHz	FCC Part 15.209 / 15.247(c)	51.0dB μ V/m @ 11652.5MHz (-3.0dB)
		5785	17				
		5825	17				

General Test Configuration

The EUT and all local support equipment were located on the turntable for radiated spurious emissions testing. All remote support equipment was located approximately 30 meters from the EUT with all I/O connections running on top of the groundplane.

For radiated emissions testing the measurement antenna was located 3 meters from the EUT.

Ambient Conditions: Temperature: 19.4 °C
Rel. Humidity: 45 %

Modifications Made During Testing

No modifications were made to the EUT during testing

Deviations From The Standard

No deviations were made from the requirements of the standard.

Client: Xirrus	Job Number: J71456
Model: XN16 and XN8	T-Log Number: T71641
	Account Manager: Susan Pezli
Contact: Steve Smith	
Standard: FCC 15.247 / RSS 210	Class: N/A

Run #1: Radiated Spurious Emissions, 1 - 40GHz. 802.11n Chains A and B Chains Active and set to highest power level

Date of Test: 5/23/2008 Config. Used: 1
 Test Engineer: Suhaila Khushzad Config Change: None
 Test Location: OATS # 1 EUT Voltage: POE

Run #1a: 802.11A, n20, n40 (all 3 channels), Chains A and C Chains Active and set to highest power level

Radio	Channel (MHz)	Mode	Power Setting		Comments
			Chain A	Chain C	
5	5745	n20	17	17	Power is the higher, single-chain power to cover MIMO & MISO modes
6	5785	n20	17	17	
8	5825	n20	17	17	
9	5755	n40	17	17	
10	5785	n40	17	17	
13	5715	n40	17	17	

Spurious Emissions(All 3 channels for n20 & n40)

Frequency MHz	Level dBμV/m	Pol v/h	15.209 / 15.247		Detector Pk/QP/Avg	Azimuth degrees	Height meters	Comments
			Limit	Margin				
11508.670	48.2	H	54.0	-5.8	AVG	65	2.1	n20 & n40
11511.500	52.9	V	54.0	-1.1	AVG	17	1.7	n20 & n40
11515.170	46.7	H	54.0	-7.3	AVG	62	2.1	n20 & n40
11571.830	47.6	H	54.0	-6.4	AVG	67	1.5	n20 & n40
11576.330	53.0	V	54.0	-1.0	AVG	96	2.1	n20 & n40
11645.580	41.4	H	54.0	-12.6	AVG	83	2.0	n20 & n40 NF
11647.250	41.8	H	54.0	-12.2	AVG	80	1.5	n20 & n40 NF
11648.920	45.1	V	54.0	-8.9	AVG	169	2.4	n20 & n40
11652.330	42.5	V	54.0	-11.5	AVG	73	1.5	n20 & n40
17255.330	49.3	V	54.0	-4.7	AVG	339	1.5	n20 & n40
17257.670	48.9	H	54.0	-5.1	AVG	321	2.2	n20 & n40
17257.830	50.0	H	54.0	-4.0	AVG	313	2.2	n20 & n40
17314.670	46.3	H	54.0	-7.7	AVG	317	2.2	n20 & n40
17352.670	46.2	V	54.0	-7.8	AVG	110	2.2	n20 & n40 NF
17401.170	46.6	H	54.0	-7.4	AVG	169	1.6	n20 & n40 NF
17416.000	46.6	V	54.0	-7.4	AVG	116	2.3	n20 & n40 NF
17416.000	46.6	V	54.0	-7.4	AVG	116	2.3	n20 & n40
17433.830	46.5	V	54.0	-7.5	AVG	349	1.0	n20 & n40 NF
17467.500	46.6	H	54.0	-7.4	AVG	89	1.8	n20 & n40 NF
11508.670	60.1	H	74.0	-13.9	PK	65	2.1	n20 & n40
11511.500	66.3	V	74.0	-7.7	PK	17	1.7	n20 & n40
11515.170	58.8	H	74.0	-15.2	PK	62	2.1	n20 & n40
11571.830	61.5	H	74.0	-12.5	PK	67	1.5	n20 & n40
11576.330	65.3	V	74.0	-8.7	PK	96	2.1	n20 & n40
11645.580	52.5	H	74.0	-21.5	PK	83	2.0	n20 & n40 NF
11647.250	53.5	H	74.0	-20.5	PK	80	1.5	n20 & n40 NF



EMC Test Data

Client: Xirrus						Job Number: J71456		
Model: XN16 and XN8						T-Log Number: T71641		
						Account Manager: Susan Pezli		
Contact: Steve Smith								
Standard: FCC 15.247 / RSS 210						Class: N/A		
11648.920	56.2	V	74.0	-17.8	PK	169	2.4	n20 & n40
11652.330	54.1	V	74.0	-19.9	PK	73	1.5	n20 & n40
17255.330	61.5	V	74.0	-12.5	PK	339	1.5	n20 & n40
17257.670	60.7	H	74.0	-13.3	PK	321	2.2	n20 & n40
17257.830	61.0	H	74.0	-13.0	PK	313	2.2	n20 & n40
17314.670	57.7	H	74.0	-16.3	PK	317	2.2	n20 & n40
17352.670	57.7	V	74.0	-16.3	PK	110	2.2	n20 & n40 NF
17401.170	58.0	H	74.0	-16.0	PK	169	1.6	n20 & n40 NF
17416.000	58.8	V	74.0	-15.2	PK	116	2.3	n20 & n40 NF
17416.000	58.8	V	74.0	-15.2	PK	116	2.3	n20 & n40
17433.830	58.8	V	74.0	-15.2	PK	349	1.0	n20 & n40 NF
17467.500	57.9	H	74.0	-16.1	PK	89	1.8	n20 & n40 NF



EMC Test Data

Client: Xirrus	Job Number: J71456
Model: XN16 and XN8	T-Log Number: T71641
	Account Manager: Susan Pezli
Contact: Steve Smith	
Standard: FCC 15.247 / RSS 210	Class: N/A

Run #1b: 802.11a, n20MHz, 40MHz (All 3 channels), Chains A and C Chains Active and set to highest power level

Radio	Channel (MHz)	Mode	Power Setting		Comments
			Chain A	Chain C	
5	5745	a	17	17	Power is the higher, single-chain power to cover MIMO & MISO modes
6	5785	a	17	17	
8	5825	a	17	17	
1	5745	n20	17	17	
9	5785	n20	17	17	
12	5825	n20	17	17	
13	5755	n40	17	17	
14	5785	n40	17	17	
16	5715	n40	17	17	

Spurious Emissions(All 3 channels for a, n20, n40 modes)

Frequency MHz	Level dBµV/m	Pol v/h	15.209 / 15.247		Detector Pk/QP/Avg	Azimuth degrees	Height meters	Comments
			Limit	Margin				
11652.500	51.0	V	54.0	-3.0	AVG	166	1.0	All modes
11652.500	64.7	V	74.0	-9.3	PK	166	1.0	All modes
11565.500	50.2	V	54.0	-3.8	AVG	342	2.0	All modes
11565.500	64.0	V	74.0	-10.0	PK	342	2.0	All modes
11490.670	49.2	V	54.0	-4.8	AVG	248	2.1	All modes
11490.670	62.8	V	74.0	-11.2	PK	248	2.1	All modes
11502.500	45.1	V	54.0	-8.9	AVG	215	2.1	All modes
11502.500	58.3	V	74.0	-15.7	PK	215	2.1	All modes
17233.830	47.8	V	54.0	-6.2	AVG	162	1.4	All modes
17233.830	59.2	V	74.0	-14.8	PK	162	1.4	All modes
17353.500	49.4	V	54.0	-4.6	AVG	334	1.5	All modes
17353.500	61.9	V	74.0	-12.1	PK	334	1.5	All modes
17498.670	46.5	V	54.0	-7.5	AVG	239	2.2	All modes
17498.670	57.4	V	74.0	-16.6	PK	239	2.2	All modes
11491.170	45.3	H	54.0	-8.7	AVG	145	2.5	All modes
11491.170	59.5	H	74.0	-14.5	PK	145	2.5	All modes
11567.000	49.5	H	54.0	-4.5	AVG	326	1.3	All modes
11567.000	62.8	H	74.0	-11.2	PK	326	1.3	All modes
11658.670	49.0	H	54.0	-5.0	AVG	122	1.9	All modes
11658.670	62.2	H	74.0	-11.8	PK	122	1.9	All modes
17229.170	48.2	H	54.0	-5.8	AVG	167	2.3	All modes
17229.170	61.1	H	74.0	-12.9	PK	167	2.3	All modes
17361.330	47.7	H	54.0	-6.3	AVG	324	2.0	All modes
17361.330	60.1	H	74.0	-13.9	PK	324	2.0	All modes
17465.330	46.9	H	54.0	-7.1	AVG	144	1.9	All modes NF
17465.330	58.1	H	74.0	-15.9	PK	144	1.9	All modes NF

Client: Xirrus	Job Number: J71456
Model: XN16 and XN8	T-Log Number: T71641
	Account Manager: Susan Pezli
Contact: Steve Smith	
Standard: FCC 15.247 / RSS 210	Class: N/A

RSS 210 and FCC 15.247 (DTS) Radiated Spurious Emissions, External Antenna

Test Specific Details

Objective: The objective of this test session is to perform final qualification testing of the EUT with respect to the specification listed above.

Summary of Results - Device Operating in the 5725-5850 MHz Band

Run #	Mode	Channel	Power Setting	Radio	Test Performed	Limit	Result / Margin
1a	802.11a External Antenna	5745	17	4	Radiated Emissions, 1 - 40 GHz	FCC Part 15.209 / 15.247(c)	45.5dBµV/m @ 17218.0MHz (-8.5dB)
1b		5785	17	4	Radiated Emissions, 1 - 40 GHz	FCC Part 15.209 / 15.247(c)	46.1dBµV/m @ 17363.5MHz (-7.9dB)
1c		5825	17	4	Radiated Emissions, 1 - 40 GHz	FCC Part 15.209 / 15.247(c)	46.8dBµV/m @ 17476.6MHz (-7.2dB)

General Test Configuration

The EUT and all local support equipment were located on the turntable for radiated spurious emissions testing. All remote support equipment was located approximately 30 meters from the EUT with all I/O connections running on top of the groundplane.

For radiated emissions testing the measurement antenna was located 3 meters from the EUT.

Ambient Conditions: Temperature: 19.4 °C
 Rel. Humidity: 45 %

Modifications Made During Testing

No modifications were made to the EUT during testing

Deviations From The Standard

No deviations were made from the requirements of the standard.



EMC Test Data

Client: Xirrus	Job Number: J71456
Model: XN16 and XN8	T-Log Number: T71641
	Account Manager: Susan Pezli
Contact: Steve Smith	
Standard: FCC 15.247 / RSS 210	Class: N/A

Run #1: Radiated Spurious Emissions, 1 - 40GHz. 802.11a Chain A Chains Active and set to highest power level

Date of Test: 5/27/2008	Config. Used: 1
Test Engineer: Suhaila Khushzad	Config Change: None
Test Location: OATS # 1	EUT Voltage: POE

Run #1a: 802.11a, 5745 MHz (Low channel), Chains A Chain Active and set to highest power level

Fundamental Signal Field Strength: Peak value measured in 100kHz

Frequency	Level	Pol	15.209 / 15.247		Detector	Azimuth	Height	Comments
MHz	dB μ V/m	v/h	Limit	Margin	Pk/QP/Avg	degrees	meters	
5741.250	88.8	H	-	-	Pk	134	1.4	Transmission on Radio 4
5746.420	98.3	V	-	-	Pk	123	1.0	RB = VB = 100kHz

Fundamental emission level @ 3m in 100kHz RBW:	98.3	dB μ V/m	
Limit for emissions outside of restricted bands:	68.3	dB μ V/m	Limit is -30dBc (UNII power measurement)

Spurious Emissions

Frequency	Level	Pol	15.209 / 15.247		Detector	Azimuth	Height	Comments
MHz	dB μ V/m	v/h	Limit	Margin	Pk/QP/Avg	degrees	meters	
17218.000	45.5	V	54.0	-8.5	AVG	314	2.5	
17248.920	45.4	H	54.0	-8.6	AVG	316	1.0	
11490.250	42.8	V	54.0	-11.2	AVG	167	1.3	
11510.670	40.0	H	54.0	-14.0	AVG	120	2.5	
17248.920	57.2	H	74.0	-16.8	PK	316	1.0	
17218.000	57.0	V	74.0	-17.0	PK	314	2.5	
11490.250	55.4	V	74.0	-18.6	PK	167	1.3	
11510.670	51.3	H	74.0	-22.7	PK	120	2.5	

Note 1: For emissions in restricted bands, the limit of 15.209 was used. For all other emissions, the limit was set 30dB below the level of the fundamental and measured in 100kHz.



EMC Test Data

Client: Xirrus	Job Number: J71456
Model: XN16 and XN8	T-Log Number: T71641
	Account Manager: Susan Pezli
Contact: Steve Smith	
Standard: FCC 15.247 / RSS 210	Class: N/A

Run #1b: 802.11a, 5785 MHz (Center channel), Chain A Active and set to highest power level

Fundamental Signal Field Strength: Peak value measured in 100kHz

Frequency	Level	Pol	15.209 / 15.247		Detector	Azimuth	Height	Comments
MHz	dB μ V/m	v/h	Limit	Margin	Pk/QP/Avg	degrees	meters	Transmission on Radio 4
5788.080	99.7	V	-	-	Pk	360	1.2	RB = VB = 100kHz
5778.330	89.8	H	-	-	Pk	126	1.0	RB = VB = 100kHz

Fundamental emission level @ 3m in 100kHz RBW:	99.7	dB μ V/m
Limit for emissions outside of restricted bands:	69.7	dB μ V/m

Limit is -30dBc (UNII power measurement)

Spurious Emissions

Frequency	Level	Pol	15.209 / 15.247		Detector	Azimuth	Height	Comments
MHz	dB μ V/m	v/h	Limit	Margin	Pk/QP/Avg	degrees	meters	
17363.500	46.1	V	54.0	-7.9	AVG	205	1.9	
17364.500	46.0	H	54.0	-8.0	AVG	70	1.0	
11563.580	40.2	H	54.0	-13.8	AVG	223	1.0	
11565.500	40.2	V	54.0	-13.8	AVG	168	1.7	
17363.500	57.5	V	74.0	-16.5	PK	205	1.9	
17364.500	57.0	H	74.0	-17.0	PK	70	1.0	
11565.500	51.8	V	74.0	-22.2	PK	168	1.7	
11563.580	51.4	H	74.0	-22.6	PK	223	1.0	

Note 1: For emissions in restricted bands, the limit of 15.209 was used. For all other emissions, the limit was set 30dB below the level of the fundamental and measured in 100kHz.

Client: Xirrus	Job Number: J71456
Model: XN16 and XN8	T-Log Number: T71641
	Account Manager: Susan Pezli
Contact: Steve Smith	
Standard: FCC 15.247 / RSS 210	Class: N/A

Run #1c: 802.11a, 5825 MHz (High channel), Chain A Active and set to highest power level
Fundamental Signal Field Strength: Peak value measured in 100kHz

Frequency	Level	Pol	15.209 / 15.247		Detector	Azimuth	Height	Comments
MHz	dB μ V/m	v/h	Limit	Margin	Pk/QP/Avg	degrees	meters	Transmission on Radio 4
5831.000	95.1	H	-	-	Pk	128	1.5	RB = VB = 100kHz
5826.420	100.7	V	-	-	Pk	291	1.2	RB = VB = 100kHz

Fundamental emission level @ 3m in 100kHz RBW:	100.7	dB μ V/m
Limit for emissions outside of restricted bands:	70.7	dB μ V/m

Limit is -30dBc (UNII power measurement)

Spurious Emissions

Frequency	Level	Pol	15.209 / 15.247		Detector	Azimuth	Height	Comments
MHz	dB μ V/m	v/h	Limit	Margin	Pk/QP/Avg	degrees	meters	
17476.580	46.8	V	54.0	-7.2	AVG	24	1.8	
17457.830	46.6	H	54.0	-7.4	AVG	187	1.0	
11650.920	42.0	V	54.0	-12.0	AVG	336	1.1	
11638.080	40.0	H	54.0	-14.0	AVG	280	2.3	
17476.580	58.2	V	74.0	-15.8	PK	24	1.8	
17457.830	58.1	H	74.0	-15.9	PK	187	1.0	
11650.920	54.6	V	74.0	-19.4	PK	336	1.1	
11638.080	51.3	H	74.0	-22.7	PK	280	2.3	

Note 1: For emissions in restricted bands, the limit of 15.209 was used. For all other emissions, the limit was set 30dB below the level of the fundamental and measured in 100kHz.



EMC Test Data

Client:	Xirrus	Job Number:	J71456
Model:	XN16 and XN8	T-Log Number:	T71645
		Account Manager:	Susan Pelzl
Contact:	Steve Smith		Mark Briggs
Emissions Standard(s):	FCC 15.109, RSS GEN, EN 55022, EN 301 489-17	Class:	B (A maybe OK)
Immunity Standard(s):	EN 301 489-1,-17 and EN 55024	Environment:	WLAN

DTS Radiated Emissions Test Data

For The

Xirrus

Model

XN16 and XN8

Date of Last Test: 6/16/2008



EMC Test Data

Client:	Xirrus	Job Number:	J71456
Model:	XN16 and XN8	T-Log Number:	T71645
Contact:	Steve Smith	Account Manger:	Susan Pelzl
Emissions Standard(s):	FCC 15.109, RSS GEN, EN 55022, EN 301 489-17	Class:	B (A maybe OK)
Immunity Standard(s):	EN 301 489-1,-17 and EN 55024	Environment:	WLAN

Test Configuration #1 - XS16

Local Support Equipment

Manufacturer	Model	Description	Serial Number	FCC ID
Xirrus	PoE60U-560(G)-SS-R	Power Injector	P7450010A1	N/A

Remote Support Equipment

Manufacturer	Model	Description	Serial Number	FCC ID
IBM	R51	Laptop	99-V4543	DoC
Netgear	GS108	Switch	GS16152CB035447	DoC

Cabling and Ports

Port	Connected To	Cable(s)		
		Description	Shielded or Unshielded	Length(m)
PoE IN	Switch	Cat 5	Unshielded	10.0
PoE Out	Data& Power IN	Cat 5	Unshielded	1.0
Data (To GIG 1/2) OUT	Ethernet 1	Cat 5	Unshielded	0.1
AC Power	PoE	3 wire	Unshielded	1.5

Note 1: The console port on the XN-16 was not connected during testing. This port is used for configuration and troubleshooting purposes only and is not intended to be connected during normal operation.

Note 2: The gigabit ethernet# 2, ethernet# 0 ports on the XN16 were not connected during testing. These ports were not exercised for this configuration

EUT Operation During Emissions Tests

During AC conducted emissions and harmonics and Flicker testing all 16 (*8 for the XS-8*) radios were transmitting at max power on the following channels: 2412 MHz 802.11b, 2472 MHz 802.11g, 2437MHz 802.11n20, 5180 MHz 802.11a, 5320 MHz 802.11n20, 5500 MHz 802.11n40, 5700 MHz 802.11a, 5825 MHz 802.11n20, 5745 MHz 802.11n 20, 5600 MHz n20, 2412 MHz 802.11n20, 2462 MHz 802.11n20, 5510MHz n40, 5690 MHz 802.11n40, 5240 MHz 802.11a, 5260 MHz 802.11a, 5280 MHz 802.11n20

During radiated emissions tests all 16 radios (*8 for the XS-8*) were in receive mode with all chains active on the following channels: 2437 MHz, 5200 MHz, 5280 MHz, 5600 MHz, 5785 MHz, 2412 MHz, 2472 MHz, 5180 MHz, 5320 MHz, 5500 MHz, 5700 MHz, 5785 MHz, 2462 MHz, 5240MHz,5260 MHz, 5540 MHz. Transmit mode emissions are covered by the relevant radio standards.

The ethernet interface was active for all tests and exercised via **??fast pings??** from the laptop PC connected to the ethernet port.

Client: Xirus	Job Number: J71456
Model: XN16 and XN8	T-Log Number: T71645
	Account Manager: Susan Pelzl
Contact: Steve Smith	
Standard: FCC 15.109, RSS GEN, EN 55022, EN 301 489-17	Class: B (A maybe OK)

Radiated Emissions, XN8 and XN16, Digital Device/Receiver

Test Specific Details

Objective: The objective of this test session is to perform final qualification testing of the EUT with respect to the specification listed above.

General Test Configuration

The EUT and all local support equipment were located on the turntable for radiated emissions testing. Remote support equipment were located outside of chamber.

The test distance and extrapolation factor (if applicable) are detailed under each run description.

Note, **preliminary** testing indicates that the emissions were maximized by orientation of the EUT and elevation of the measurement antenna. **Maximized** testing indicated that the emissions were maximized by orientation of the EUT, elevation of the measurement antenna, and manipulation of the EUT's interface cables.

Ambient Conditions: Temperature: 18 °C
 Rel. Humidity: 48 %

Summary of Results

Run #	Test Performed	Limit	Result	Margin
1	RE, 30 - 1000MHz Maximized Emissions (XN8)	RSS GEN / FCC 15.107	Pass	44.8dBµV/m (173.8µV/m) @ 350.00MHz (-1.2dB)
		EN 55022 B	Pass	36.5dBµV/m @ 750.01MHz (-0.5dB)
2	RE, 30 - 1000MHz Maximized Emissions (XN16)	RSS GEN / FCC 15.107	Pass	44.2dBµV/m @ 349.999MHz (-1.8dB)
		EN 55022 B	Pass	36.0dBµV/m @ 349.999MHz (-1.0dB)

Modifications Made During Testing

No modifications were made to the EUT during testing

Deviations From The Standard

No deviations were made from the requirements of the standard.



EMC Test Data

Client: Xirrus	Job Number: J71456
Model: XN16 and XN8	T-Log Number: T71645
	Account Manager: Susan Pelzl
Contact: Steve Smith	
Standard: FCC 15.109, RSS GEN, EN 55022, EN 301 489-17	Class: B (A maybe OK)

Run #1: Radiated Emissions, 30-1000 MHz, XN8

Receive mode, all 8 radios as follows with all chains active: 2437 MHz, 5260MHz, 5600 MHz, 5785 MHz (internal antenna) and 2437 MHz, 5260MHz, 5600 MHz, 5785 MHz (external antenna).

Model XN-8, Preliminary Scan (Anechoic Chamber)

Frequency MHz	Level dB μ V/m	Pol V/H	EN 55022 Class B		Detector Pk/QP/Avg	Azimuth degrees	Height meters	Comments
			Limit	Margin				
35.009	47.3	V	30.0	17.3	Peak	89	1.7	
75.666	26.7	H	30.0	-3.3	Peak	301	1.7	
349.999	32.7	H	37.0	-4.3	Peak	82	1.7	
450.000	28.2	V	37.0	-8.8	Peak	339	1.7	
750.009	27.6	V	37.0	-9.4	Peak	74	1.7	
500.000	26.4	V	37.0	-10.6	Peak	146	1.7	
850.000	26.1	V	37.0	-10.9	Peak	313	1.7	
874.991	25.7	V	37.0	-11.3	Peak	307	1.7	
125.000	17.7	V	30.0	-12.3	Peak	44	1.7	
649.991	23.7	V	37.0	-13.3	Peak	258	1.7	
300.000	23.5	V	37.0	-13.5	Peak	63	1.7	
625.026	22.2	V	37.0	-14.8	Peak	252	1.7	
249.988	19.8	H	37.0	-17.2	Peak	286	1.7	

Client: Xirrus	Job Number: J71456
Model: XN16 and XN8	T-Log Number: T71645
	Account Manager: Susan Pelzl
Contact: Steve Smith	
Standard: FCC 15.109, RSS GEN, EN 55022, EN 301 489-17	Class: B (A maybe OK)

Model XN-8, OATS - Preliminary measurements

Date of Test: 5/28/2008
 Test Engineer: Mehran Birgani
 Test Location: SVOATS #2

Config. Used: 1
 Config Change: None
 EUT Voltage: POE

Frequency Range	Test Distance	Limit Distance	Extrapolation Factor
30 - 1000 MHz	3	3	0.0

Frequency	Level	Pol	FCC 15.109 Class B		Detector	Azimuth	Height	Comments
MHz	dB μ V/m	v/h	Limit	Margin	Pk/QP/Avg	degrees	meters	
349.999	44.8	H	46.0	-1.2	QP	297	1.0	QP (1.00s)
250.003	44.3	H	46.0	-1.7	QP	307	1.2	QP (1.00s)
625.008	42.9	V	46.0	-3.1	QP	83	1.0	QP (1.00s)
500.000	41.5	V	46.0	-4.5	QP	67	1.2	QP (1.00s)
850.000	40.5	V	46.0	-5.5	QP	235	1.0	QP (1.00s)
349.999	40.4	V	46.0	-5.6	QP	228	1.0	QP (1.00s)
750.009	40.0	V	46.0	-6.0	QP	189	1.4	QP (1.00s)
650.000	39.2	V	46.0	-6.8	QP	146	1.0	QP (1.00s)
300.016	37.2	V	46.0	-8.8	QP	231	1.0	QP (1.00s)
125.000	31.1	V	43.5	-12.4	QP	174	1.0	QP (1.00s)
35.009	25.6	V	40.0	-14.4	QP	113	1.0	QP (1.00s)
450.000	28.7	V	46.0	-17.3	QP	315	1.3	QP (1.00s)
75.666	20.8	H	40.0	-19.2	QP	269	2.7	QP (1.00s)

Note 1: Emissions below 1GHz were independent of operating mode (Transmit vs. Receive) and operating channel of the transceivers. The data above was taken with all 16 receivers active and demonstrates compliance with the requirements for receivers, digital devices and transmitters by complying with the radiated emissions limits of FCC 15.109 and FCC 15.209 and RSS GEN.

Model XN-8, OATS - Maximized Measurements

Frequency	Level	Pol	FCC 15.109 Class B		Detector	Azimuth	Height	Comments
MHz	dB μ V/m	v/h	Limit	Margin	Pk/QP/Avg	degrees	meters	
250.003	44.3	H	46.0	-1.7	QP	307	1.2	QP (1.00s)
349.999	44.8	H	46.0	-1.2	QP	297	1.0	QP (1.00s)
349.999	40.4	V	46.0	-5.6	QP	228	1.0	QP (1.00s)
500.000	41.5	V	46.0	-4.5	QP	67	1.2	QP (1.00s)
625.008	42.9	V	46.0	-3.1	QP	83	1.0	QP (1.00s)
850.000	40.5	V	46.0	-5.5	QP	235	1.0	QP (1.00s)

Client: Xirrus	Job Number: J71456
Model: XN16 and XN8	T-Log Number: T71645
	Account Manager: Susan Pelzl
Contact: Steve Smith	
Standard: FCC 15.109, RSS GEN, EN 55022, EN 301 489-17	Class: B (A maybe OK)

Model XN-8, OATS - Maximized Measurements at 10m against EN 55022 Limits

Frequency Range	Test Distance	Limit Distance	Extrapolation Factor
30 - 1000 MHz	10	10	0.0

Frequency	Level	Pol	EN 55022 Class B		Detector	Azimuth	Height	Comments
MHz	dB μ V/m	v/h	Limit	Margin	Pk/QP/Avg	degrees	meters	
250.003	36.0	H	37.0	-1.0	QP	230	3.3	QP (1.00s)
349.999	35.2	H	37.0	-1.8	QP	288	2.6	QP (1.00s)
349.999	34.6	V	37.0	-2.4	QP	312	1.0	QP (1.00s)
500.000	33.6	V	37.0	-3.4	QP	104	3.3	QP (1.00s)
625.008	32.4	V	37.0	-4.6	QP	83	1.0	Note 2, QP (1.00s)
750.009	36.5	V	37.0	-0.5	QP	145	1.6	QP (1.00s)
850.000	36.2	V	37.0	-0.8	QP	112	1.8	QP (1.00s)

Note 1: Emissions below 1GHz were independent of operating mode (Transmit vs. Receive) and operating channel of the transceivers. The data above was taken with all 16 receivers active and demonstrates compliance with the requirements for Class B ITE equipment.

Note 2: Measured at 3m and extrapolated to 10m by using -10.5dB correction.

Run #2: Radiated Emissions, 30-1000 MHz, XN16

Receive mode, all 16 radios as follows with all chains active: 2437 MHz, 5200 MHz, 5280 MHz, 5600 MHz, 5785 MHz, 2412 MHz, 2472 MHz, 5180 MHz, 5320 MHz, 5500 MHz, 5700 MHz, 5785 MHz (remaining 4 radios tuned to 2462 MHz, 5240MHz, 5260 MHz, 5540 MHz)

Model XN-16, Preliminary Scan (Anechoic Chamber)

Frequency	Level	Pol	EN 55022 Class B		Detector	Azimuth	Height	
MHz	dB μ V/m	V/H	Limit	Margin	Pk/QP/Avg	degrees	meters	XN-8 Prelim Level
38.526	41.1	V	30.0	11.1	Peak	164	1.7	
63.686	30.2	V	30.0	0.2	Peak	194	1.7	
500.002	34.6	V	37.0	-2.4	Peak	301	1.7	26.4
349.999	33.7	H	37.0	-3.3	Peak	118	1.7	32.7
875.013	28.0	V	37.0	-9.0	Peak	181	1.7	25.7
450.009	27.4	V	37.0	-9.6	Peak	61	1.7	28.2
749.991	26.9	V	37.0	-10.1	Peak	181	1.7	27.6
550.000	26.8	V	37.0	-10.2	Peak	271	1.7	
300.004	26.2	H	37.0	-10.8	Peak	118	1.7	23.5
849.993	26.0	V	37.0	-11.0	Peak	211	1.7	26.1
250.006	23.0	H	37.0	-14.0	Peak	91	1.7	19.8

Client: Xirrus	Job Number: J71456
Model: XN16 and XN8	T-Log Number: T71645
	Account Manager: Susan Pelzl
Contact: Steve Smith	
Standard: FCC 15.109, RSS GEN, EN 55022, EN 301 489-17	Class: B (A maybe OK)

Model XN-16, OATS - Preliminary measurements

Frequency Range	Test Distance	Limit Distance	Extrapolation Factor
30 - 1000 MHz	3	3	0.0

Frequency MHz	Level dB μ V/m	Pol v/h	FCC 15.109 Class B		Detector Pk/QP/Avg	Azimuth degrees	Height meters	Comments
			Limit	Margin				
349.999	44.1	V	46.0	-1.9	QP	353	1.0	
349.999	43.4	H	46.0	-2.6	QP	219	1.0	
450.000	41.9	V	46.0	-4.1	QP	94	1.0	
38.526	34.8	V	40.0	-5.2	QP	178	1.0	
550.000	40.7	H	46.0	-5.3	QP	57	1.0	
500.018	40.6	V	46.0	-5.4	QP	227	1.0	
300.000	40.4	H	46.0	-5.6	QP	43	1.0	
550.000	38.5	V	46.0	-7.5	QP	207	1.5	
300.000	37.6	V	46.0	-8.4	QP	357	1.0	
250.006	35.6	H	46.0	-10.4	QP	40	1.1	
500.000	35.4	H	46.0	-10.6	QP	144	1.6	
450.000	35.0	H	46.0	-11.0	QP	262	1.0	
63.686	28.1	V	40.0	-11.9	QP	153	1.0	
250.006	32.3	V	46.0	-13.7	QP	19	1.0	
63.686	25.0	H	40.0	-15.0	QP	70	2.8	
38.526	21.9	H	40.0	-18.1	QP	109	2.9	

Model XN-16, OATS - Maximized Measurements

Frequency MHz	Level dB μ V/m	Pol v/h	FCC 15.109 Class B		Detector Pk/QP/Avg	Azimuth degrees	Height meters	Comments
			Limit	Margin				
349.999	44.2	V	46.0	-1.8	QP	354	1.0	
349.999	44.0	H	46.0	-2.0	QP	219	1.0	
450.000	42.3	V	46.0	-3.7	QP	94	1.0	
38.526	35.4	V	40.0	-4.6	QP	180	1.0	
550.000	41.0	H	46.0	-5.0	QP	57	1.0	
500.018	40.9	V	46.0	-5.1	QP	220	1.0	

Note 1: Emissions below 1GHz were independent of operating mode (Transmit vs. Receive) and operating channel of the transceivers. The data above was taken with all 16 receivers active and demonstrates compliance with the requirements for receivers, digital devices and transmitters by complying with the radiated emissions limits of FCC 15.109 and FCC 15.209 and RSS GEN.

Client: Xirrus	Job Number: J71456
Model: XN16 and XN8	T-Log Number: T71645
	Account Manager: Susan Pelzl
Contact: Steve Smith	
Standard: FCC 15.109, RSS GEN, EN 55022, EN 301 489-17	Class: B (A maybe OK)

Model XN-16, OATS - Maximized Measurements at 10m against EN 55022 Limits

Frequency Range	Test Distance	Limit Distance	Extrapolation Factor
30 - 1000 MHz	10	10	0.0

Note to engineer: Measure top 6 signals plus any other signals with less than 6dB of margin against FCC limit at 10m versus EN B

Frequency MHz	Level dB μ V/m	Pol v/h	EN 55022 Class B		Detector Pk/QP/Avg	Azimuth degrees	Height meters	Comments
			Limit	Margin				
349.999	36.0	V	37.0	-1.0	QP	348	1.0	
38.526	28.6	V	30.0	-1.4	QP	360	1.0	
550.000	33.0	H	37.0	-4.0	QP	150	1.1	
450.000	32.9	V	37.0	-4.1	QP	320	1.0	
500.000	32.1	V	37.0	-4.9	QP	300	2.9	
349.999	31.9	H	37.0	-5.1	QP	228	2.6	
300.000	31.0	H	37.0	-6.0	QP	33	2.5	

Note 1: Emissions below 1GHz were independent of operating mode (Transmit vs. Receive) and operating channel of the transceivers. The data above was taken with all 16 receivers active and demonstrates compliance with the requirements for Class B ITE equipment.

Client: Xirrus	Job Number: J71456
Model: XN16 and XN8	T-Log Number: T71645
	Account Manager: Susan Pelzl
Contact: Steve Smith	
Standard: FCC 15.109, RSS GEN, EN 55022, EN 301 489-17	Class: B (A maybe OK)

Run #1: Radiated Emissions, 1 - 18GHz, XN8

Receive mode, all 8 radios as follows with all chains active: 2437 MHz, 5280 MHz, 2412 MHz, 5600 MHz, 2472 MHz, 5785 MHz, 5180 MHz, 5700 MHz.

Model XN-8, Preliminary Scan (Anechoic Chamber)

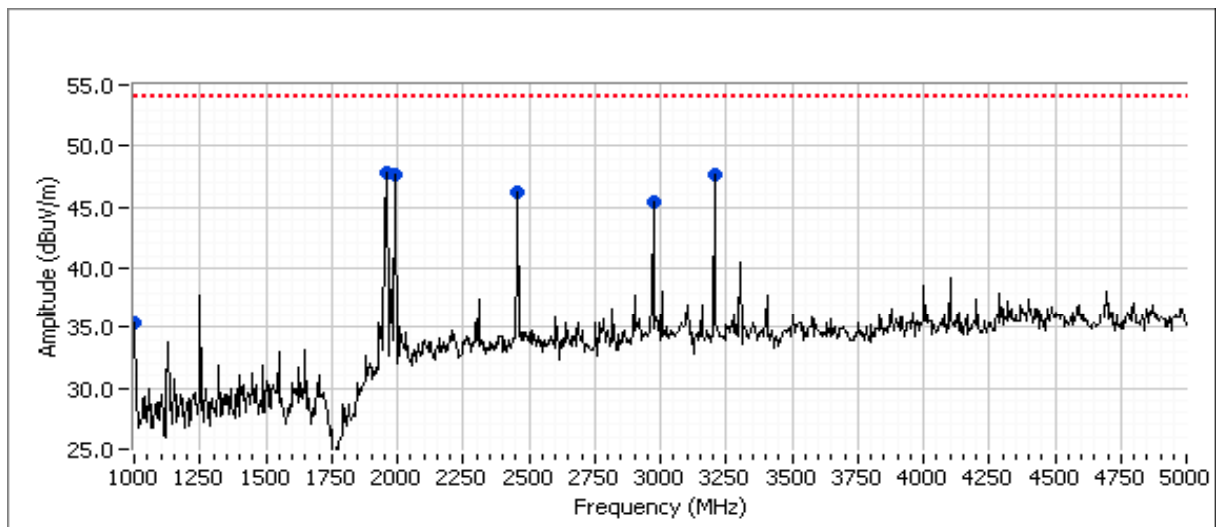

Frequency MHz	Level dBµV/m	Pol v/h	Class B		Detector Pk/QP/Avg	Azimuth degrees	Height meters	Comments
			Limit	Margin				
1958.650	47.8	H	54.0	-6.2	Peak	176	1.7	
1989.300	47.7	H	54.0	-6.3	Peak	134	1.7	
2455.740	46.3	H	54.0	-7.7	Peak	313	1.7	
2970.040	45.5	V	54.0	-8.5	Peak	102	1.7	
3200.050	47.7	V	54.0	-6.3	Peak	0	1.7	
2973.500	45.5	V	54.0	-8.5	Peak	102	1.7	
3204.500	47.7	V	54.0	-6.3	Peak	0	1.7	
7660.830	40.1	V	54.0	-13.9	Peak	326	1.7	Peak reading with average limit



EMC Test Data

Client: Xirus	Job Number: J71456
Model: XN16 and XN8	T-Log Number: T71645
	Account Manager: Susan Pelzl
Contact: Steve Smith	
Standard: FCC 15.109, RSS GEN, EN 55022, EN 301 489-17	Class: B (A maybe OK)

Model XN-8, OATS

Date of Test: 5/28/2008
 Test Engineer: Mehran Birgani
 Test Location: SVOATS #2

Config. Used: 1
 Config Change: None
 EUT Voltage: POE

Frequency Range	Test Distance	Limit Distance	Extrapolation Factor
1000 - 18000 MHz	3	3	0.0

Frequency MHz	Level dB μ V/m	Pol V/H	FCC 15.109 Class B		Detector Pk/QP/Avg	Azimuth degrees	Height meters	Comments
			Limit	Margin				
1000.002	36.2	H	54.0	-17.8	AVG	88	1.1	RB 1.000 MHz; VB: 10 Hz
2455.510	37.6	H	54.0	-16.4	AVG	276	1.0	RB 1.000 MHz; VB: 10 Hz
2969.970	45.1	V	54.0	-8.9	AVG	92	1.3	RB 1.000 MHz; VB: 10 Hz
3199.990	46.8	V	54.0	-7.2	AVG	351	1.3	RB 1.000 MHz; VB: 10 Hz
1000.002	43.6	H	74.0	-30.4	PK	88	1.1	RB 1.000 MHz; VB: 1.000 MHz
2454.400	47.3	H	74.0	-26.7	PK	276	1.0	RB 1.000 MHz; VB: 1.000 MHz
2970.010	51.4	V	74.0	-22.6	PK	92	1.3	RB 1.000 MHz; VB: 1.000 MHz
3200.020	54.2	V	74.0	-19.8	PK	351	1.3	RB 1.000 MHz; VB: 1.000 MHz

Note 1: Above 1 GHz, the FCC specifies the limit as an average measurement. In addition, the FCC states that the peak reading of any emission above 1 GHz, can not exceed the average limit by more than 20 dB.

Note 2: Frequencies selected based on preliminary scans performed in an anechoic chamber.

Client: Xirrus	Job Number: J71456
Model: XN16 and XN8	T-Log Number: T71645
	Account Manager: Susan Pelzl
Contact: Steve Smith	
Standard: FCC 15.109, RSS GEN, EN 55022, EN 301 489-17	Class: B (A maybe OK)

Run #2: Radiated Emissions, 1 - 18GHz, XN16

Receive mode, all 16 radios as follows with all chains active: 2437 MHz, 5200 MHz, 5280 MHz, 5600 MHz, 5785 MHz, 2412 MHz, 2472 MHz, 5180 MHz, 5320 MHz, 5500 MHz, 5700 MHz, 5785 MHz (remaining 4 radios tuned to 2462 MHz, 5240MHz, 5260 MHz, 5540 MHz)

Date of Test: Config. Used: 1
 Test Engineer: Config Change: None
 Test Location: EUT Voltage: POE

Model XN-16, Preliminary Scan (Anechoic Chamber)

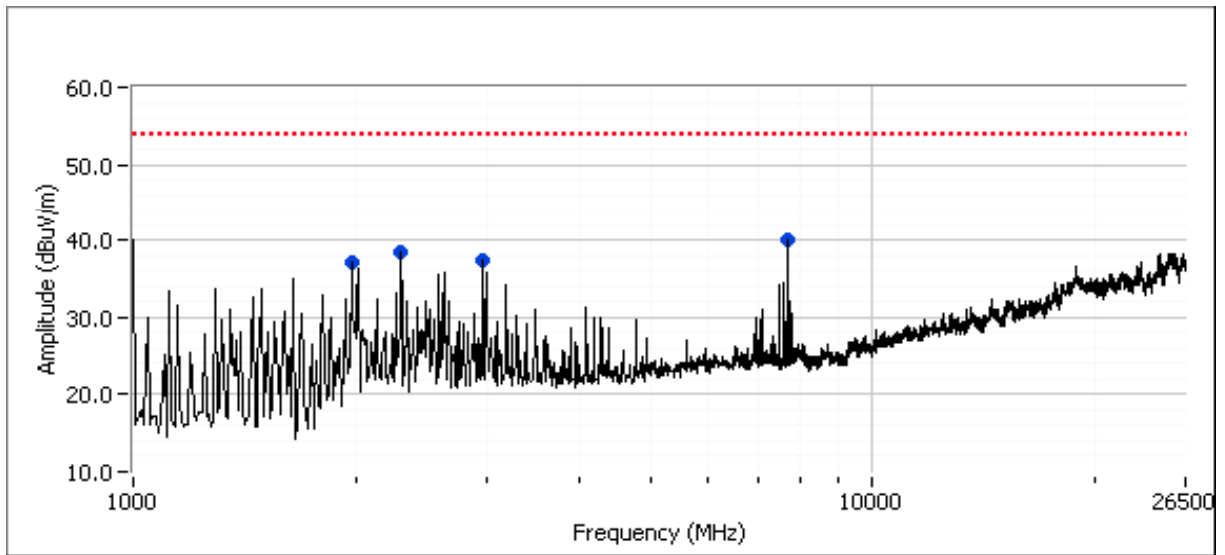

Frequency	Level	Pol	FCC 15.109 Class B		Detector	Azimuth	Height	Comments
MHz	dB μ V/m	V/H	Limit	Margin	Pk/QP/Avg	degrees	meters	
1001.000	40.0	V	54.0	-10.0	Peak	0	1.7	
7660.830	40.1	V	54.0	-13.9	Peak	326	1.7	Peak reading with average limit
2301.670	38.5	V	54.0	-15.5	Peak	49	1.7	Peak reading with average limit
2970.830	37.4	V	54.0	-16.6	Peak	340	1.7	Peak reading with average limit
1971.670	37.1	H	54.0	-16.9	Peak	94	1.7	Peak reading with average limit



EMC Test Data

Client: Xirrus	Job Number: J71456
Model: XN16 and XN8	T-Log Number: T71645
	Account Manager: Susan Pelzl
Contact: Steve Smith	
Standard: FCC 15.109, RSS GEN, EN 55022, EN 301 489-17	Class: B (A maybe OK)

Model XN-16, OATS

Date of Test: 5/30/2008
 Test Engineer: Suhaila Khushzad
 Test Location: OATS # 1

Config. Used: 1
 Config Change: None
 EUT Voltage: POE

Frequency Range	Test Distance	Limit Distance	Extrapolation Factor
1000 - 18000 MHz	3	3	0.0

Note to engineer - need to tune to all signals, values approximate only.

Frequency	Level	Pol	FCC 15.109 Class B		Detector	Azimuth	Height	Comments
MHz	dB μ V/m	V/H	Limit	Margin	Pk/QP/Avg	degrees	meters	
2291.740	47.2	H	54.0	-6.8	AVG	360	2.5	
1000.000	45.8	V	54.0	-8.2	AVG	312	1.0	
2970.000	45.2	V	54.0	-8.8	AVG	175	1.7	
7660.000	44.7	H	54.0	-9.3	AVG	85	1.2	
7659.750	44.4	V	54.0	-9.6	AVG	174	1.9	
2969.910	43.0	H	54.0	-11.0	AVG	82	1.4	
2291.740	60.2	H	74.0	-13.8	PK	360	2.5	
2310.190	38.4	V	54.0	-15.6	AVG	203	1.7	
1000.100	33.5	H	54.0	-20.5	AVG	203	1.0	
7660.000	51.7	H	74.0	-22.3	PK	85	1.2	
7659.750	51.5	V	74.0	-22.5	PK	174	1.9	
2310.190	48.9	V	74.0	-25.1	PK	203	1.7	
2970.000	48.2	V	74.0	-25.8	PK	175	1.7	
1000.000	48.1	V	74.0	-25.9	PK	312	1.0	
2969.910	47.4	H	74.0	-26.6	PK	82	1.4	
1000.100	41.6	H	74.0	-32.4	PK	203	1.0	

Note 1: Above 1 GHz, the FCC specifies the limit as an average measurement. In addition, the FCC states that the peak reading of any emission above 1 GHz, can not exceed the average limit by more than 20 dB.

Note 2: Frequencies selectd based on preliminary scans performed in an anechoic chamber.

Client: Xirrus	Job Number: J71456
Model: XN16 and XN8	T-Log Number: T71645
	Account Manager: Susan Pelzl
Contact: Steve Smith	
Standard: FCC 15.109, RSS GEN, EN 55022, EN 301 489-17	Class: B (A maybe OK)

Conducted Emissions - Power Ports

Test Specific Details

Objective: The objective of this test session is to perform final qualification testing of the EUT with respect to the specification listed above.

Date of Test: 6/3/2008	Config. Used: 1
Test Engineer: Chris Groat	Config Change: none
Test Location: SVOATS #1	EUT Voltage: 230V/50Hz & 120V/60Hz

General Test Configuration

The EUT was located on a wooden table, 40 cm from a vertical coupling plane and 80cm from the LISN. A second LISN was used for all local support equipment. Remote support equipment was located approximately 30 meters from the test area. All I/O connections were routed overhead.

Ambient Conditions: Temperature: 23 °C
 Rel. Humidity: 43 %

Summary of Results

Run #	Test Performed	Limit	Result	Margin
1	CE, AC Power, 230V/50Hz Model XN16	EN 55022 Class B	Pass	41.3dBµV @ 0.469MHz (-5.2dB)
2	CE, AC Power, 120V/60Hz Model XN16	FCC 15.109 Class B FCC 15.209 RSS GEN	Pass	42.8dBµV @ 4.670MHz (-3.2dB)
3	CE, AC Power, 230V/50Hz Model XN8	EN 55022 Class B		Covered by XN16 as worst case
4	CE, AC Power, 120V/60Hz Model XN8	FCC 15.109 Class B FCC 15.209 RSS GEN		Covered by XN16 as worst case

Modifications Made During Testing

No modifications were made to the EUT during testing

Deviations From The Standard

No deviations were made from the requirements of the standard.

Client: Xirus	Job Number: J71456
Model: XN16 and XN8	T-Log Number: T71645
	Account Manager: Susan Pelzl
Contact: Steve Smith	
Standard: FCC 15.109, RSS GEN, EN 55022, EN 301 489-17	Class: B (A maybe OK)

Run #1: AC Power Port Conducted Emissions, 0.15 - 30MHz, 230V/50Hz MODEL XN16

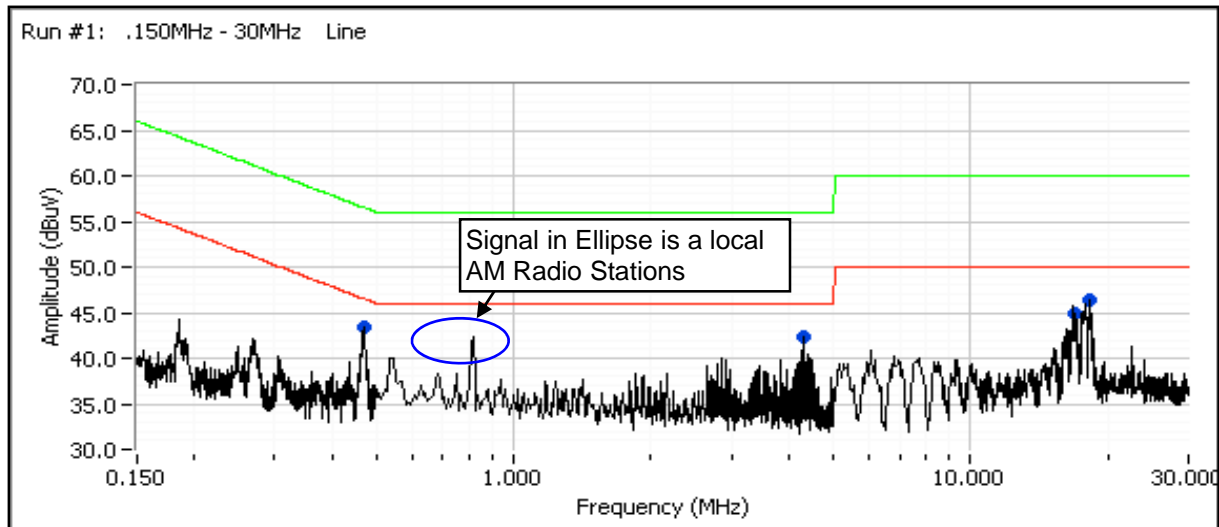
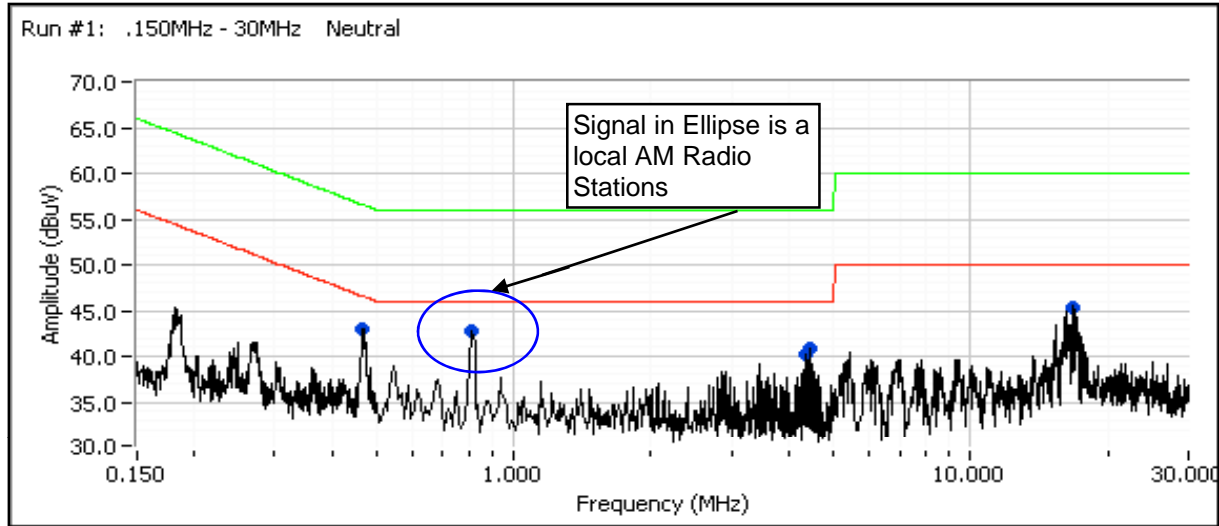



EMC Test Data

Client: Xirrus	Job Number: J71456
Model: XN16 and XN8	T-Log Number: T71645
	Account Manager: Susan Pelzl
Contact: Steve Smith	
Standard: FCC 15.109, RSS GEN, EN 55022, EN 301 489-17	Class: B (A maybe OK)

Run #1: AC Power Port Conducted Emissions, 0.15 - 30MHz, 230V/50Hz MODEL XN16

Frequency MHz	Level dB μ V	AC Line	EN55022 B		Detector QP/Ave	Comments
			Limit	Margin		
0.469	41.3	Line 1	46.5	-5.2	AVG	
0.468	41.1	Neutral	46.5	-5.4	AVG	
4.460	38.7	Neutral	46.0	-7.3	AVG	
4.399	38.6	Neutral	46.0	-7.4	AVG	
16.893	38.5	Neutral	50.0	-11.5	AVG	
4.347	33.0	Line 1	46.0	-13.0	AVG	
16.909	35.6	Line 1	50.0	-14.4	AVG	
0.468	40.8	Neutral	56.5	-15.7	QP	
0.469	40.8	Line 1	56.5	-15.7	QP	
4.460	38.5	Neutral	56.0	-17.5	QP	
4.399	38.3	Neutral	56.0	-17.7	QP	
16.893	41.9	Neutral	60.0	-18.1	QP	
18.275	30.9	Line 1	50.0	-19.1	AVG	
16.909	40.7	Line 1	60.0	-19.3	QP	
4.347	33.3	Line 1	56.0	-22.7	QP	
18.275	36.9	Line 1	60.0	-23.1	QP	

Client: Xirrus	Job Number: J71456
Model: XN16 and XN8	T-Log Number: T71645
	Account Manager: Susan Pelzl
Contact: Steve Smith	
Standard: FCC 15.109, RSS GEN, EN 55022, EN 301 489-17	Class: B (A maybe OK)

Run #2: AC Power Port Conducted Emissions, 0.15 - 30MHz, 120V/60Hz MODEL XN16

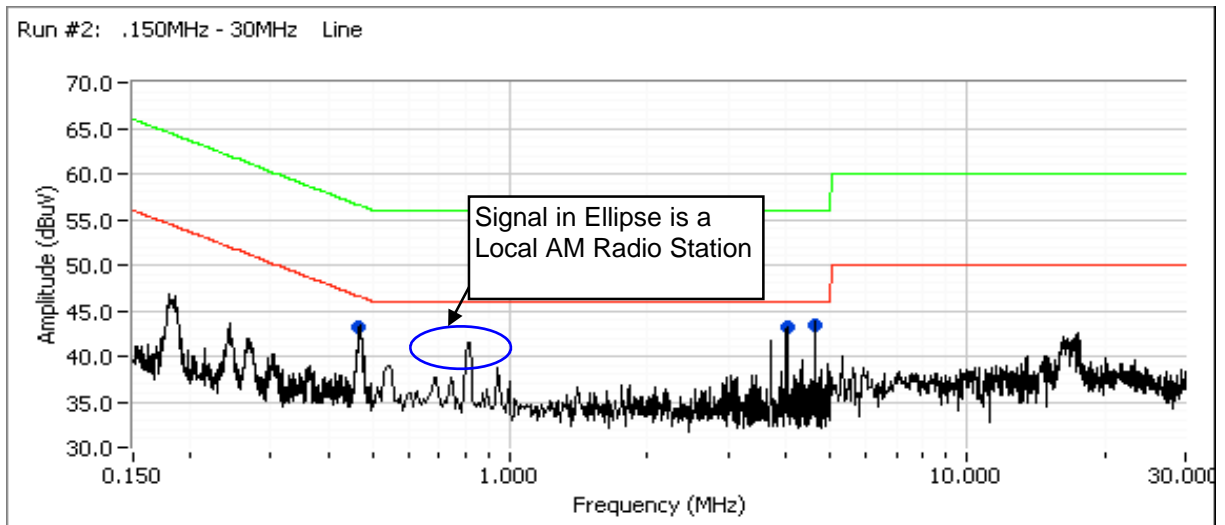
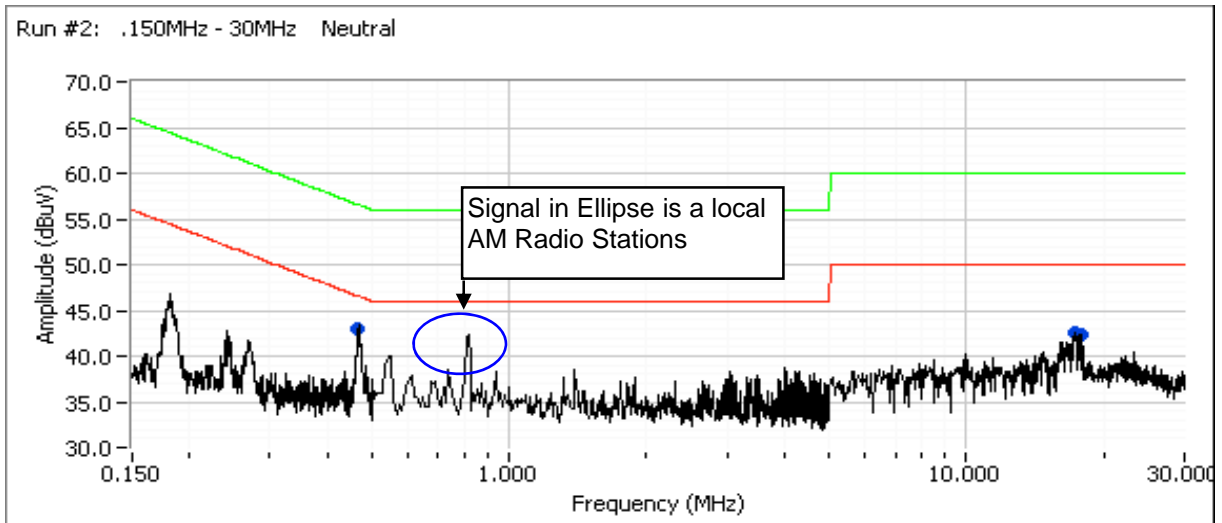



EMC Test Data

Client: Xirrus	Job Number: J71456
Model: XN16 and XN8	T-Log Number: T71645
	Account Manager: Susan Pelzl
Contact: Steve Smith	
Standard: FCC 15.109, RSS GEN, EN 55022, EN 301 489-17	Class: B (A maybe OK)

Run #2: AC Power Port Conducted Emissions, 0.15 - 30MHz, 120V/60Hz MODEL XN16

Frequency MHz	Level dB μ V	AC Line	EN55022 B		Detector QP/Ave	Comments
			Limit	Margin		
4.670	42.8	Line 1	46.0	-3.2	AVG	
0.469	41.4	Line 1	46.5	-5.1	AVG	
0.469	41.2	Neutral	46.5	-5.3	AVG	
4.047	40.3	Line 1	46.0	-5.7	AVG	
4.670	45.3	Line 1	56.0	-10.7	QP	
17.316	38.3	Neutral	50.0	-11.7	AVG	
4.047	42.8	Line 1	56.0	-13.2	QP	
17.676	35.7	Neutral	50.0	-14.3	AVG	
0.469	41.0	Line 1	56.5	-15.5	QP	
0.469	40.9	Neutral	56.5	-15.6	QP	
17.316	41.4	Neutral	60.0	-18.6	QP	
17.676	39.6	Neutral	60.0	-20.4	QP	

EXHIBIT 3: Photographs of Test Configurations

2 Pages