

*Electromagnetic Emissions Test Report
Application for Grant of Equipment Authorization
pursuant to
FCC Part 15, Subpart E
on the
Xirrus, Inc.
Transmitter
Model: XN16, XN12 and XN8*

FCC ID: SK6XN16 SK6XN12 SK6XN8

GRANTEE: Xirrus, Inc.
370 North Westlake Blvd., Suite 200
Westlake Village, CA 91362

TEST SITE: Elliott Laboratories
684 W. Maude Ave
Sunnyvale, CA 94086

REPORT DATE: June 5, 2008

REISSUE DATE: September 5, 2008

FINAL TEST DATE: May 15, May 22, May 28, May 29
and June 2, 2008

AUTHORIZED SIGNATORY:



Mark Briggs
Principal Engineer



Testing Cert #2016-01

Elliott Laboratories is accredited by the A2LA, certificate number 2016-01, to perform the test(s) listed in this report. This report shall not be reproduced, except in its entirety, without the written approval of Elliott Laboratories

REVISION HISTORY

Rev #	Date	Comments	Modified By
1	June 18, 2008	Initial Release	Dave Guidotti
2	June 24, 2008	<p>Revised product description to detail power reduction for multi-radio operation in the 2.4GHz band when operating in 802.11b MIMO mode.</p> <p>The test data appendix was updated to:</p> <ul style="list-style-type: none"> Reflect correct calculations of EIRP in n20 and n40 modes in the power summary Reference dual-chain MIMO operation rather than triple chain operation Power tables for n40 clarified to show output power is capable of being reduced to below 14dBm on both 40MHz channels in the 5150 – 5250 MHz band with two radios operating in the band 	Mark Briggs
3	9/5/08	<p>Reissued to add XN12 model to the scope of the test report. The XN12 model name, FCCID, and IC UPN were added to the cover page and the EUT details section was revised to include a description of the XN12.</p>	Dave Guidotti Mark Briggs

TABLE OF CONTENTS

COVER PAGE	1
REVISION HISTORY	2
TABLE OF CONTENTS	3
SCOPE	4
OBJECTIVE	4
STATEMENT OF COMPLIANCE	5
TEST RESULTS SUMMARY	5
UNII / LELAN DEVICES	5
GENERAL REQUIREMENTS APPLICABLE TO ALL BANDS	6
MEASUREMENT UNCERTAINTIES	7
EQUIPMENT UNDER TEST (EUT) DETAILS	8
GENERAL.....	8
OTHER EUT DETAILS.....	9
ANTENNA SYSTEM	9
ENCLOSURE.....	9
MODIFICATIONS.....	9
SUPPORT EQUIPMENT.....	9
EUT INTERFACE PORTS	10
EUT OPERATION	10
TEST SITE	11
GENERAL INFORMATION.....	11
CONDUCTED EMISSIONS CONSIDERATIONS	11
RADIATED EMISSIONS CONSIDERATIONS	11
MEASUREMENT INSTRUMENTATION	12
RECEIVER SYSTEM	12
INSTRUMENT CONTROL COMPUTER	12
LINE IMPEDANCE STABILIZATION NETWORK (LISN)	12
FILTERS/ATTENUATORS	13
ANTENNAS.....	13
ANTENNA MAST AND EQUIPMENT TURNTABLE.....	13
INSTRUMENT CALIBRATION.....	13
TEST PROCEDURES	14
EUT AND CABLE PLACEMENT	14
CONDUCTED EMISSIONS.....	14
RADIATED EMISSIONS.....	14
RADIATED EMISSIONS.....	15
CONDUCTED EMISSIONS FROM ANTENNA PORT	19
BANDWIDTH MEASUREMENTS	19
SPECIFICATION LIMITS AND SAMPLE CALCULATIONS.....	20
GENERAL TRANSMITTER RADIATED EMISSIONS SPECIFICATION LIMITS	20
FCC 15.407 (A) OUTPUT POWER LIMITS.....	21
OUTPUT POWER AND SPURIOUS LIMITS –UNII DEVICES	21
SAMPLE CALCULATIONS - CONDUCTED EMISSIONS	22
SAMPLE CALCULATIONS - RADIATED EMISSIONS	22
SAMPLE CALCULATIONS - FIELD STRENGTH TO EIRP CONVERSION	23
EXHIBIT 1: Test Equipment Calibration Data	1
EXHIBIT 2: Test Measurement Data	2
EXHIBIT 3: Photographs of Test Configurations	3

SCOPE

An electromagnetic emissions test has been performed on the Xirrus, Inc. models XN16 and XN8 pursuant to the following rules:

FCC Part 15, Subpart E requirements for UNII Devices (using FCC DA 02-2138, August 30, 2002)

Conducted and radiated emissions data has been collected, reduced, and analyzed within this report in accordance with measurement guidelines set forth in the following reference standards and as outlined in Elliott Laboratories test procedures:

ANSI C63.4:2003

FCC UNII test procedure 2002-08 DA-02-2138, August 2002

The intentional radiator above has been tested in a simulated typical installation to demonstrate compliance with the relevant Industry Canada performance and procedural standards.

Final system data was gathered in a mode that tended to maximize emissions by varying orientation of EUT, orientation of power and I/O cabling, antenna search height, and antenna polarization.

Every practical effort was made to perform an impartial test using appropriate test equipment of known calibration. All pertinent factors have been applied to reach the determination of compliance.

The test results recorded herein are based on a single type test of the Xirrus, Inc. models XN16 and XN8 and therefore apply only to the tested sample. The sample was selected and prepared by Steve Smith of Xirrus, Inc.

Testing performed on the XN16 and XN 8 was considered representative of the XN12.

OBJECTIVE

The primary objective of the manufacturer is compliance with the regulations outlined in the previous section.

Prior to marketing in the USA, all unlicensed transmitters and transceivers require certification. Receive-only devices operating between 30 MHz and 960 MHz are subject to either certification or a manufacturer's declaration of conformity, with all other receive-only devices exempt from the technical requirements.

Certification is a procedure where the manufacturer submits test data and technical information to a certification body and receives a certificate or grant of equipment authorization upon successful completion of the certification body's review of the submitted documents. Once the equipment authorization has been obtained, the label indicating compliance must be attached to all identical units, which are subsequently manufactured.

Maintenance of compliance is the responsibility of the manufacturer. Any modification of the product which may result in increased emissions should be checked to ensure compliance has been maintained (i.e., printed circuit board layout changes, different line filter, different power supply, harnessing or I/O cable changes, etc.).

STATEMENT OF COMPLIANCE

The tested sample of Xirrus, Inc. models XN16 and XN8 complied with the requirements of the following regulations:

FCC Part 15, Subpart E requirements for UNII Devices

Maintenance of compliance is the responsibility of the manufacturer. Any modification of the product which may result in increased emissions should be checked to ensure compliance has been maintained (i.e., printed circuit board layout changes, different line filter, different power supply, harnessing or I/O cable changes, etc.).

TEST RESULTS SUMMARY

UNII / LELAN DEVICES

Operation in the 5.15 – 5.25 GHz Band

FCC Rule Part	RSS Rule Part	Description	Measured Value / Comments	Limit / Requirement	Result
15.407(e)		Indoor operation only	Designed for indoor use only	N/A	Complies
15.407(a) (1)		26dB Bandwidth	> 24.6 MHz	N/A – limits output power if < 20MHz	N/A
15.407 (a) (1)	A9.2(1)	Output Power – Single Radio	a: 16.3 dBm a 2x: 13.3 dBm n20: 16.7 dBm n40: 16.7 dBm (46.8 mW)	17dBm (14dBm for 802.11a MIMO mode)	Complies
15.407 (a) (1)	A9.2(1)	Output Power – 4x Radios (2x n40)	a: 16.7 dBm a 2x: 13.7 dBm n20: 16.9 dBm (48.9 mW) n40: 16.6 dBm		Complies
15.407 (a) (1)		Power Spectral Density	a: 3.9dBm/MHz a 2x: 0.9dBm/MHz n20: 4.0 dBm/MHz n40: 0.8 dBm/MHz	4 dBm/MHz (1dBm/MHz for 802.11a MIMO mode)	Complies
	A9.5 (2)		Complies		
<p>Note s</p> <p>Output power limit for multi-chain (MIMO) in 802.11a mode (noted as a 2x above) is reduced to 14dBm and the PSD limit is reduced to 1dBm/MHz as the effective antenna gain becomes 9dBi (exceeds 6dBi by 3dB). As the device contains multiple radios and can operate on non-overlapping channels the table includes the output power with one radio and with four radios operating in the band.</p>					

General requirements for all UNII bands

FCC Rule Part	RSS Rule Part	Description	Measured Value / Comments	Limit / Requirement	Result
	A9.5a	Modulation	Digital Modulation is used	Digital modulation is required	Complies
	RSP 100	99% bandwidth	a: 16.9 MHz n20: 18.4 MHz n40: 36.8 MHz	Information only	
15.407(b) (5) / 15.209	A9.3	Spurious Emissions below 1GHz	No emissions related to transmitter below 1GHz. Digital device meets Class B limits.		-
15.407(b) (2)	A9.3	Spurious Emissions above 1GHz	53.2dB μ V/m (457.1 μ V/m) @ 5149.6MHz	-27dBm/MHz / 15.209	Complies (- 0.8 dB)
15.407(a) (6)	-	Peak Excursion Ratio		< 13dB	Complies
	A9.5 (3)	Channel Selection	Spurious emissions tested at outermost channels in each band	Device was tested on the top, bottom and center channels in each band	N/A
15.407 (c)	A9.5(4)	Operation in the absence of information to transmit	Operation is discontinued in the absence of information (Operational Description page 13)	Device shall automatically discontinue operation in the absence of information to transmit	Complies
15.407 (g)	A9.5 (5)	Frequency Stability	Frequency stability is 5ppm (Operational Description page 13 of 17)	Signal shall remain in-band.	Complies
15.407 (h1)	A9.4	Transmit Power Control	Not applicable, device does not operate in either 5470 – 5725 or 5250 – 5350 MHz bands.		
15.407 (h2)	A9.4	Dynamic frequency Selection (device with radar detection)			

GENERAL REQUIREMENTS APPLICABLE TO ALL BANDS

FCC Rule Part	RSS Rule part	Description	Measured Value / Comments	Limit / Requirement	Result (margin)
15.203	-	RF Connector	Internal antenna or reverse polarity TNC	Integral or unique connector	Complies
15.207	RSS GEN Table 2	AC Conducted Emissions	42.8dB μ V @ 4.670MHz	Refer to standard	Complies (- 3.2 dB)
15.247 (b) (5) / 15.407 (f)	RSS 102	RF Exposure Requirements	Refer to MPE calculations in Exhibit 11, and User Manual statements.	Refer to OET 65, FCC Part 1 and RSS 102	Complies

MEASUREMENT UNCERTAINTIES

ISO/IEC 17025 requires that an estimate of the measurement uncertainties associated with the emissions test results be included in the report. The measurement uncertainties given below are based on a 95% confidence level and were calculated in accordance with UKAS document LAB 34.

Measurement Type	Frequency Range (MHz)	Calculated Uncertainty (dB)
Conducted Emissions	0.15 to 30	± 2.4
Radiated Emissions	0.015 to 30	± 3.0
Radiated Emissions	30 to 1000	± 3.6
Radiated Emissions	1000 to 40000	± 6.0

EQUIPMENT UNDER TEST (EUT) DETAILS**GENERAL**

The Xirrus, Inc. models XN16, XN12 and XN8 are multi-radio 802.11abgn Access Points which are designed to act as a hub for a wireless local area network (WLAN). The electrical rating of the device is 100/240Vac, 50/60Hz, 0.5-3A. They can be powered via an internal AC-DC adapter or via a PoE interface and dedicated PoE adapter (also sold with the device). Transmitter measurements were made with the device powered via PoE. Digital device emissions were measured with the device powered from the AC-DC adapter to cover both methods of powering the device.

The model XN16 contains 16 separate transceivers. The radio interfaces are provided via four identical circuit boards. Each of the boards has one 802.11bgn radio and three 802.11an radios. Each radio connects to an internal antenna with a gain of 3dBi for the bgn radio and 6dBi for the an radio. Three radio boards can connect to an external antenna via a reverse polarity TNC coaxial connector. The external antenna offered for use is a ceiling mount antenna, model CM2-2400/5500, with a nominal gain of 2.5dBi for all bands and is used to support single-chain legacy modes. The internal antennas support single-chain legacy modes and 3x3 MIMO modes for 2.4GHz, 2x2 MIMO for 5GHz.

The XN8 and XN12 are both identical to the XN16 except that the rf board is depopulated.

1. In the XN8 there are only two transceivers on each radio board, one that can operate as abgn in both 2.4GHz and 5GHz bands and the other that can operate only in the 5GHz bands as an 802.11an radio. The XN8 has a total of 8 transceivers.
2. In the XN12 there are only three transceivers on each radio board, one that can operate as a bgn radio in the 2.4GHz band, the other two operate in the 5GHz bands as an 802.11an radio. The XN12 has a total of 12 transceivers.

The individual radios operate independently i.e. they are not configured to transmit the same data but are designed to operate independent networks. The system firmware configures the radios such that no two radios can operate on overlapping channels. Additionally output power per radio may be adjusted to ensure the output power in the 5150 – 5250 MHz, 5250 – 5350 MHz and 5470 – 5725 MHz bands remains below the output power and EIRP limits per band when more than one radio is operating in a band. Power reductions for multi-radio operation in the 2.4 GHz is also implemented for 802.11b MIMO mode. For all other 2.4 GHz modes, and for operation in the 5GHz DTS band, power reduction is not required because the output power (30dBm) and EIRP (36dBm) limits are met when one or multiple radios are operating in those bands, given the restrictions for no two radios operating on overlapping channels. As there are only 3 non-overlapping 2.4GHz channels the fourth 802.11bgn radio is used in a receive-only mode to monitor for rogue APs and perform other security functions.

Normally, the EUT's would be ceiling mounted during operation. The EUT's were tested as both tabletop equipment and also tested with the EUT raised to a height of 1.5m above the ground plane. The highest transmitter emissions were found with the device elevated to a height of 1.5m above the ground plane and final measurements were made with the EUT at that height.

The sample was received on May 28, 2008 and tested on May 15, May 22, May 28, May 29 and June 2, 2008. The EUT consisted of the following component(s):

Manufacturer	Model	Description	Serial Number	FCC ID
Xirrus	XN16	802.11abgn access point	Prototype	SK6XN16
Xirrus	XN8	802.11abgn access point	Prototype	SK6XN8
Xirrus	PoE60U-560(G)-SS-R	Power Injector	P7450010A1	N/A

OTHER EUT DETAILS

Testing performed on the XN16 and XN8 was considered representative of the XN12. The XN12 contains 12 transceivers and one radio board has been removed from each board.

ANTENNA SYSTEM

The antennas are either integral to the device or connect to the EUT via a non-standard, reverse gender TNC connector, thereby meeting the requirements of FCC 15.203.

ENCLOSURE

The enclosures for the XN16, XN12 and XN8 are identical. The enclosure is primarily constructed of plastic. It is circular with a diameter of 48 cm and a height of 10cm.

MODIFICATIONS

The EUT did not require modifications during testing in order to comply with emissions specifications.

SUPPORT EQUIPMENT

The following equipment was used as remote support equipment for emissions testing:

Manufacturer	Model	Description	Serial Number	FCC ID
IBM	R51	Laptop	99-V4543	DoC
Netgear	GS108	Switch	GS16152CB0354 47	DoC

EUT INTERFACE PORTS

The I/O cabling configuration during emissions testing was as follows:

Port	Connected To	Cable(s)		
		Description	Shielded or Unshielded	Length(m)
PoE adapter PoE IN	Switch	Cat 5	Unshielded	10.0
PoE adapter PoE Out	XN-x Data& Power IN	Cat 5	Unshielded	1.0
XN-x Data (To GIG 1/2) OUT	Ethernet 1	Cat 5	Unshielded	0.1
AC Power	PoE	3 wire	Unshielded	1.5

Note 1: The console port on the XN-16 was not connected during testing. This port is used for configuration and troubleshooting purposes only and is not intended to be connected during normal operation.

Note 2: The gigabit ethernet# 2, ethernet# 0 ports on the XN16 were not connected during testing. These ports were not exercised for this configuration.

EUT OPERATION

During AC conducted emissions all 16 radios were transmitting at max power on the following channels: 2412 MHz 802.11b, 2472 MHz 802.11g, 2437MHz 802.11n20, 5180 MHz 802.11a, 5320 MHz 802.11n20, 5500 MHz 802.11n40, 5700 MHz 802.11a, 5825 MHz 802.11n20, 5745 MHz 802.11n 20, 5600 MHz n20, 2412 MHz 802.11n20, 2462 MHz 802.11n20, 5510MHz n40, 5690 MHz 802.11n40, 5240 MHz 802.11a, 5260 MHz 802.11a, 5280 MHz 802.11n20.

During radiated emissions tests all 16 radios (8 for the XS-8) were in receive mode with all chains active on the following channels: 2437 MHz, 5200 MHz, 5280 MHz, 5600 MHz, 5785 MHz, 2412 MHz, 2472 MHz, 5180 MHz, 5320 MHz, 5500 MHz, 5700 MHz, 5785 MHz, 2462 MHz, 5240MHz,5260 MHz, 5540 MHz.

Transmit mode emissions were made with a single transceiver operational for band-edge radiated measurements and rf port measurements. The transmit chain(s) were transmitting continuously. Spurious measurements were made with one radio in 802.11a mode, one in 802.11n20 mode and one in 802.11n40 mode transmitting continuously on top and bottom and, where applicable, center channel.

Additionally a scan was made with all radios operational in different bands to verify that no inter-modulation products of significance were produced. The scan was made with a horn antenna close to the device. No signals were observed other than the harmonics of the individual signals measured during the spurious emissions tests.

Radiated emissions measurements made below 1GHz indicated that the emissions were all related to the digital device (i.e. they did not change when the radios were enabled or disabled, or when the operating frequencies of the radios were changed). Radiated emissions below 1GHz are therefore covered by the Part 15 Class B digital device verification test report.

TEST SITE

GENERAL INFORMATION

Final test measurements were taken on May 15, May 22, May 28, May 29 and June 2, 2008 at the Elliott Laboratories Open Area Test Site #1 & 2 located at 684 West Maude Avenue, Sunnyvale, California. Pursuant to section 2.948 of the FCC's Rules and section 3.3 of RSP-100, construction, calibration, and equipment data has been filed with the Commission.

ANSI C63.4:2003 recommends that ambient noise at the test site be at least 6 dB below the allowable limits. Ambient levels are below this requirement with the exception of predictable local TV, radio, and mobile communications traffic. The test site contains separate areas for radiated and conducted emissions testing. Considerable engineering effort has been expended to ensure that the facilities conform to all pertinent requirements of ANSI C63.4:2003.

CONDUCTED EMISSIONS CONSIDERATIONS

Conducted emissions testing is performed in conformance with ANSI C63.4:2003. Measurements are made with the EUT connected to the public power network through a nominal, standardized RF impedance, which is provided by a line impedance stabilization network, known as a LISN. A LISN is inserted in series with each current-carrying conductor in the EUT power cord.

RADIATED EMISSIONS CONSIDERATIONS

The FCC has determined that radiation measurements made in a shielded enclosure are not suitable for determining levels of radiated emissions. Radiated measurements are performed in an open field environment or in a semi-anechoic chamber. The test sites are maintained free of conductive objects within the CISPR defined elliptical area incorporated in ANSI C63.4:2003 guidelines and meet the Normalized Site Attenuation (NSA) requirements of ANSI C63.4:2003.

MEASUREMENT INSTRUMENTATION

RECEIVER SYSTEM

An EMI receiver as specified in CISPR 16-1 is used for emissions measurements. The receivers used can measure over the frequency range of 9 kHz up to 2000 MHz. These receivers allow both ease of measurement and high accuracy to be achieved. The receivers have Peak, Average, and CISPR (Quasi-peak) detectors built into their design so no external adapters are necessary. The receiver automatically sets the required bandwidth for the CISPR detector used during measurements. If the repetition frequency of the signal being measured is below 20Hz, peak measurements are made in lieu of Quasi-Peak measurements.

For measurements above the frequency range of the receivers, a spectrum analyzer is utilized because it provides visibility of the entire spectrum along with the precision and versatility required to support engineering analysis. Average measurements above 1000MHz are performed on the spectrum analyzer using the linear-average method with a resolution bandwidth of 1 MHz and a video bandwidth of 10 Hz, unless the signal is pulsed in which case the average (or video) bandwidth of the measuring instrument is reduced to onset of pulse desensitization and then increased.

INSTRUMENT CONTROL COMPUTER

The receivers utilize either a Rohde & Schwarz EZM Spectrum Monitor/Controller or contain an internal Spectrum Monitor/Controller to view and convert the receiver measurements to the field strength at an antenna or voltage developed at the LISN measurement port, which is then compared directly with the appropriate specification limit. This provides faster, more accurate readings by performing the conversions described under Sample Calculations within the Test Procedures section of this report. Results are printed in a graphic and/or tabular format, as appropriate. A personal computer is used to record all measurements made with the receivers.

The Spectrum Monitor provides a visual display of the signal being measured. In addition, the controller or a personal computer run automated data collection programs which control the receivers. This provides added accuracy since all site correction factors, such as cable loss and antenna factors are added automatically.

LINE IMPEDANCE STABILIZATION NETWORK (LISN)

Line conducted measurements utilize a fifty microhenry Line Impedance Stabilization Network as the monitoring point. The LISN used also contains a 250 uH CISPR adapter. This network provides for calibrated radio frequency noise measurements by the design of the internal low pass and high pass filters on the EUT and measurement ports, respectively.

FILTERS/ATTENUATORS

External filters and precision attenuators are often connected between the receiving antenna or LISN and the receiver. This eliminates saturation effects and non-linear operation due to high amplitude transient events.

ANTENNAS

A loop antenna is used below 30 MHz. For the measurement range 30 MHz to 1000 MHz either a combination of a biconical antenna and a log periodic or a bi-log antenna is used. Above 1000 MHz, horn antennas are used. The antenna calibration factors to convert the received voltage to an electric field strength are included with appropriate cable loss and amplifier gain factors to determine an overall site factor, which is then programmed into the test receivers or incorporated into the test software.

ANTENNA MAST AND EQUIPMENT TURNTABLE

The antennas used to measure the radiated electric field strength are mounted on a non-conductive antenna mast equipped with a motor-drive to vary the antenna height. Measurements below 30 MHz are made with the loop antenna at a fixed height of 1m above the ground plane.

ANSI C63.4:2003 specifies that the test height above ground for table mounted devices shall be 80 centimeters. Floor mounted equipment shall be placed on the ground plane if the device is normally used on a conductive floor or separated from the ground plane by insulating material from 3 to 12 mm if the device is normally used on a non-conductive floor. During radiated measurements, the EUT is positioned on a motorized turntable in conformance with this requirement.

INSTRUMENT CALIBRATION

All test equipment is regularly checked to ensure that performance is maintained in accordance with the manufacturer's specifications. All antennas are calibrated at regular intervals with respect to tuned half-wave dipoles. An exhibit of this report contains the list of test equipment used and calibration information.

TEST PROCEDURES

EUT AND CABLE PLACEMENT

The regulations require that interconnecting cables be connected to the available ports of the unit and that the placement of the unit and the attached cables simulate the worst case orientation that can be expected from a typical installation, so far as practicable. To this end, the position of the unit and associated cabling is varied within the guidelines of ANSI C63.4:2003, and the worst-case orientation is used for final measurements.

CONDUCTED EMISSIONS

Conducted emissions are measured at the plug end of the power cord supplied with the EUT. Excess power cord length is wrapped in a bundle between 30 and 40 centimeters in length near the center of the cord. Preliminary measurements are made to determine the highest amplitude emission relative to the specification limit for all the modes of operation. Placement of system components and varying of cable positions are performed in each mode. A final peak mode scan is then performed in the position and mode for which the highest emission was noted on all current carrying conductors of the power cord.

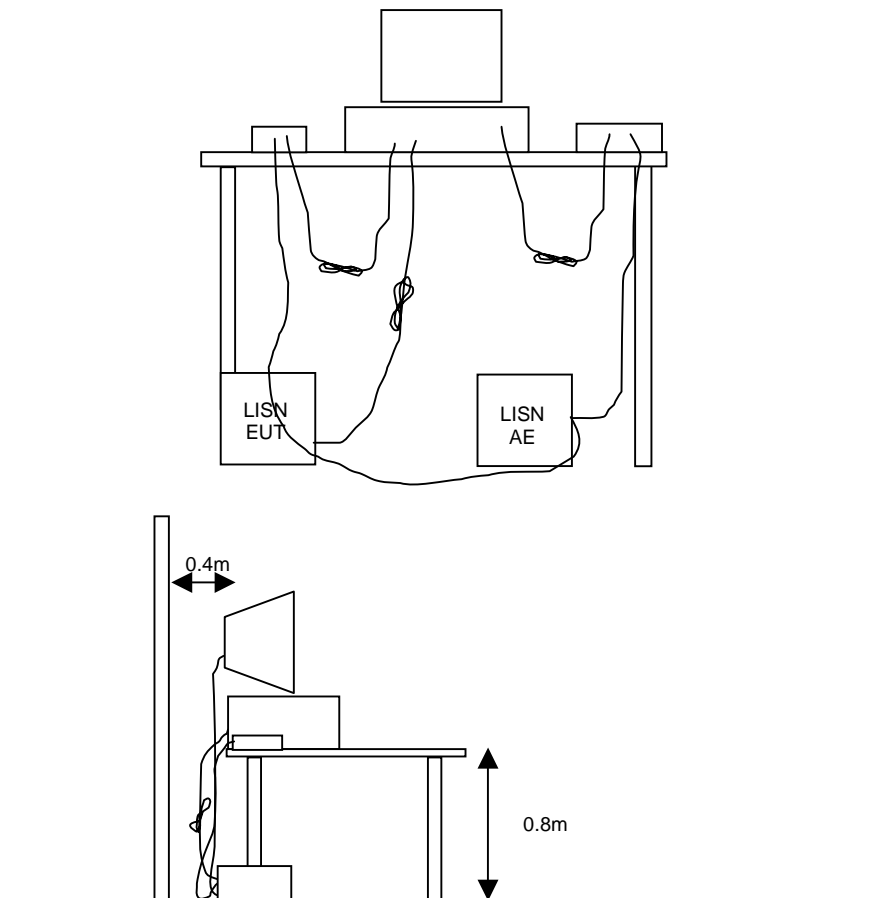

RADIATED EMISSIONS

A preliminary scan of the radiated emissions is performed in which all significant EUT frequencies are identified with the system in a nominal configuration. At least two scans are performed, one scan for each antenna polarization (horizontal and vertical; loop parallel and perpendicular to the EUT). During the preliminary scans, the EUT is rotated through 360°, the antenna height is varied (for measurements above 30 MHz) and cable positions are varied to determine the highest emission relative to the limit. Preliminary scans may be performed in a fully anechoic chamber for the purposes of identifying the frequencies of the highest emissions from the EUT.

A speaker is provided in the receiver to aid in discriminating between EUT and ambient emissions. Other methods used during the preliminary scan for EUT emissions involve scanning with near field magnetic loops, monitoring I/O cables with RF current clamps, and cycling power to the EUT.

Final maximization is a phase in which the highest amplitude emissions identified in the spectral search are viewed while the EUT azimuth angle is varied from 0 to 360 degrees relative to the receiving antenna. The azimuth, which results in the highest emission is then maintained while varying the antenna height from one to four meters (for measurements above 30 MHz, measurements below 30 MHz are made with the loop antenna at a fixed height of 1m). The result is the identification of the highest amplitude for each of the highest peaks. Each recorded level is corrected in the receiver using appropriate factors for cables, connectors, antennas, and preamplifier gain.

When testing above 18 GHz, the receive antenna is located at 1 meter from the EUT and the antenna height is restricted to a maximum of 2.5 meters.

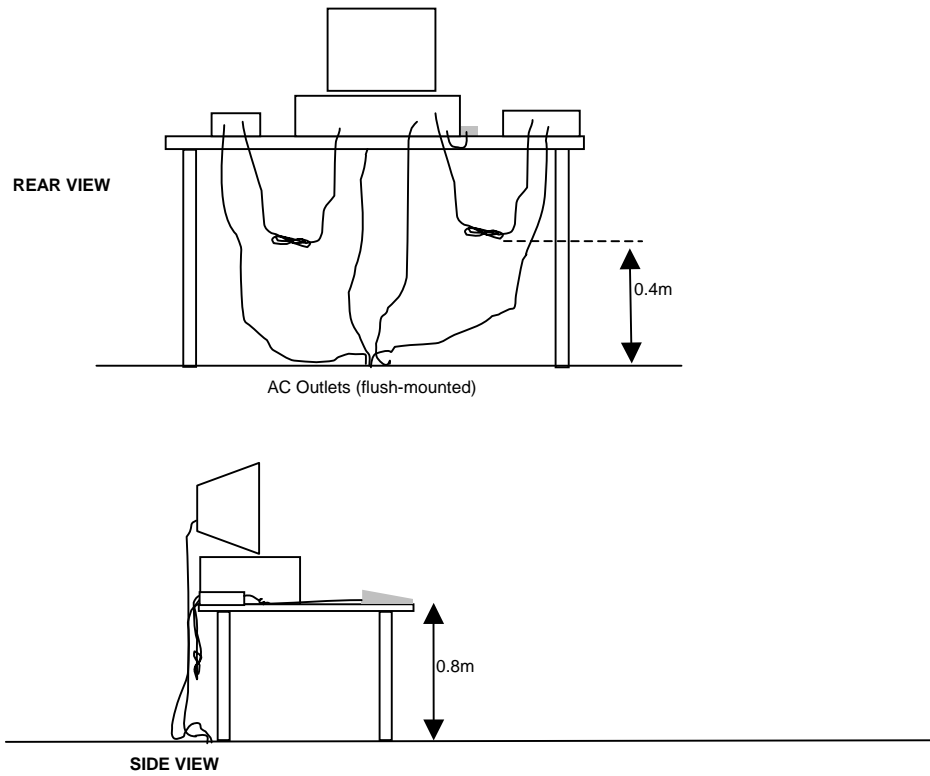

Typical Test Configuration for Radiated Field Strength Measurements

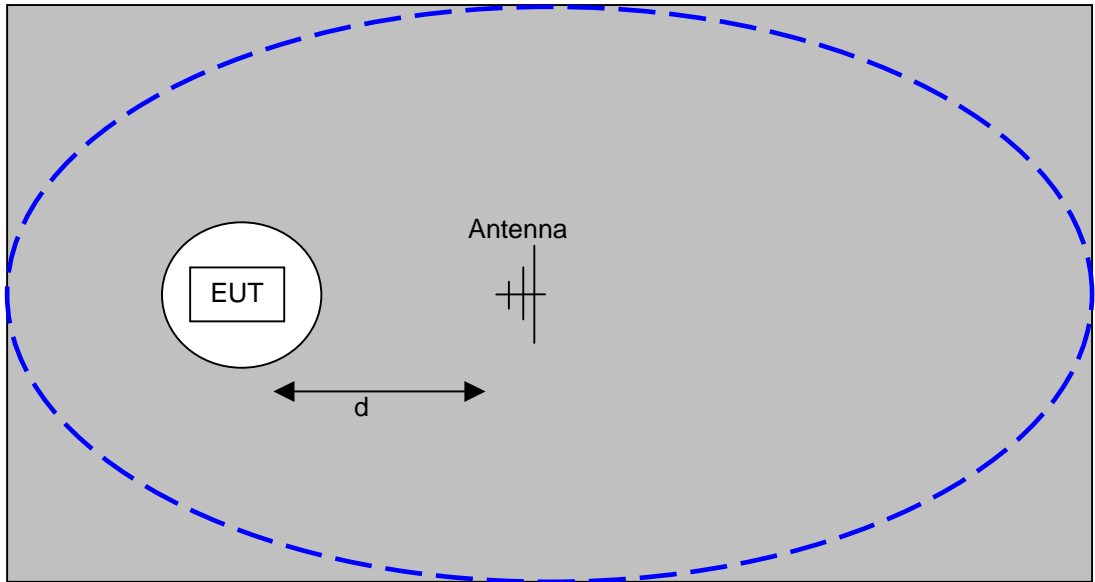

The ground plane extends beyond the ellipse defined in CISPR 16 / CISPR 22 / ANSI C63.4 and is large enough to accommodate test distances (d) of 3m and 10m. Refer to the test data tables for the actual measurement distance.

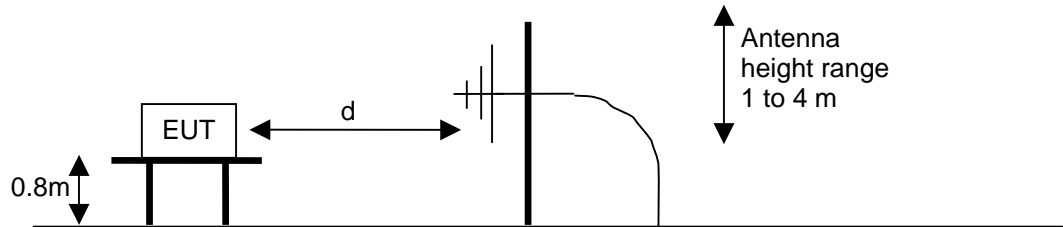

Test Configuration for Radiated Field Strength Measurements
OATS- Plan and Side Views

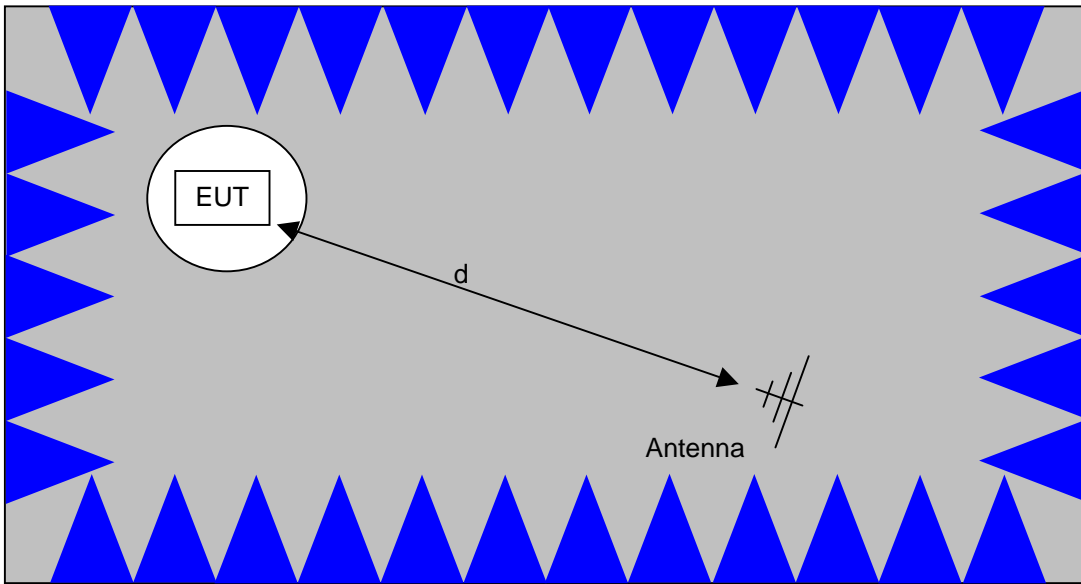

The anechoic materials on the walls and ceiling ensure compliance with the normalized site attenuation requirements of CISPR 16 / CISPR 22 / ANSI C63.4 for an alternate test site at the measurement distances used.

Floor-standing equipment is placed on the floor with insulating supports between the unit and the ground plane.

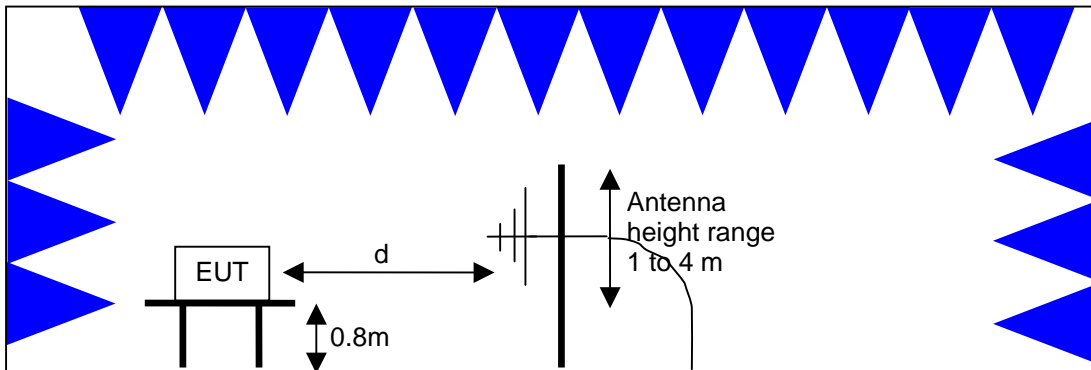

Test Configuration for Radiated Field Strength Measurements
Semi-Anechoic Chamber, Plan and Side Views

CONDUCTED EMISSIONS FROM ANTENNA PORT

Direct measurements of power, bandwidth and power spectral density are performed, where possible, with the antenna port of the EUT connected to either the power meter or spectrum analyzer via a suitable attenuator and/or filter. These are used to ensure that the front end of the measurement instrument is not overloaded by the fundamental transmission.

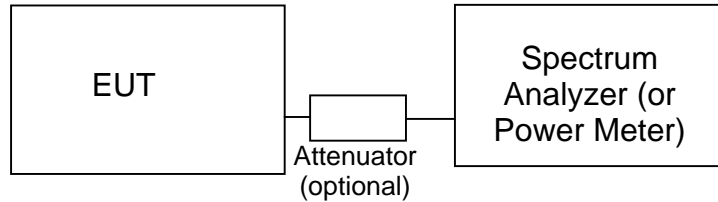

Test Configuration for Antenna Port Measurements

Measurement bandwidths (video and resolution) are set in accordance with the relevant standards and Elliott's test procedures for the type of radio being tested. When power measurements are made using a resolution bandwidth less than the signal bandwidth the power is calculated by summing the power across the signal bandwidth using either the analyzer channel power function or by capturing the trace data and calculating the power using software. In both cases the summed power is corrected to account for the equivalent noise bandwidth (ENBW) of the resolution bandwidth used.

If power averaging is used (typically for certain digital modulation techniques), the EUT is configured to transmit continuously. Power averaging is performed using either the built-in function of the analyzer or, if the analyzer does not feature power averaging, using external software. In both cases the average power is calculated over a number of sweeps (typically 100). When the EUT cannot be configured to continuously transmit then either the analyzer is configured to perform a gated sweep to ensure that the power is averaged over periods that the device is transmitting or power averaging is disabled and a max-hold feature is used.

If a power meter is used to make output power measurements the sensor head type (peak or average) is stated in the test data table.

BANDWIDTH MEASUREMENTS

The 6dB, 20dB and/or 26dB signal bandwidth is measured in using the bandwidths recommended by ANSI C63.4. When required, the 99% bandwidth is measured using the methods detailed in RSS GEN.

SPECIFICATION LIMITS AND SAMPLE CALCULATIONS

The limits for conducted emissions are given in units of microvolts, and the limits for radiated emissions are given in units of microvolts per meter at a specified test distance. Data is measured in the logarithmic form of decibels relative to one microvolt, or dB microvolts (dBuV). For radiated emissions, the measured data is converted to the field strength at the antenna in dB microvolts per meter (dBuV/m). The results are then converted to the linear forms of uV and uV/m for comparison to published specifications.

For reference, converting the specification limits from linear to decibel form is accomplished by taking the base ten logarithm, then multiplying by 20. These limits in both linear and logarithmic form are as follows:

GENERAL TRANSMITTER RADIATED EMISSIONS SPECIFICATION LIMITS

The table below shows the limits for the spurious emissions from transmitters that fall in restricted bands¹ (with the exception of transmitters operating under FCC Part 15 Subpart D and RSS 210 Annex 9), the limits for all emissions from a low power device operating under the general rules of RSS 310 (tables 3 and 4), RSS 210 (table 2) and FCC Part 15 Subpart C section 15.209.

Frequency Range (MHz)	Limit (uV/m)	Limit (dBuV/m @ 3m)
0.009-0.490	$2400/F_{\text{KHz}} @ 300\text{m}$	$67.6-20*\log_{10}(F_{\text{KHz}}) @ 300\text{m}$
0.490-1.705	$24000/F_{\text{KHz}} @ 30\text{m}$	$87.6-20*\log_{10}(F_{\text{KHz}}) @ 30\text{m}$
1.705 to 30	30 @ 30m	29.5 @ 30m
30 to 88	100 @ 3m	40 @ 3m
88 to 216	150 @ 3m	43.5 @ 3m
216 to 960	200 @ 3m	46.0 @ 3m
Above 960	500 @ 3m	54.0 @ 3m

¹ The restricted bands are detailed in FCC 15.203, RSS 210 Table 1 and RSS 310 Table 2

FCC 15.407 (a) OUTPUT POWER LIMITS

The table below shows the limits for output power and output power density. Where the signal bandwidth is less than 20 MHz the maximum output power is reduced to the power spectral density limit plus 10 times the log of the bandwidth (in MHz).

Operating Frequency (MHz)	Output Power	Power Spectral Density
5150 - 5250	50mW (17 dBm)	4 dBm/MHz
5250 - 5350	250 mW (24 dBm)	11 dBm/MHz
5725 – 5825	1 Watts (30 dBm)	17 dBm/MHz

For system using antennas with gains exceeding 6dBi, the output power and power spectral density limits are reduced by 1dB for every dB the antenna gain exceeds 6dBi. Fixed point-to-point applications using the 5725 – 5825 MHz band may use antennas with gains of up to 23dBi without this limitation. If the gain exceeds 23dBi then the output power limit of 1 Watt is reduced by 1dB for every dB the gain exceeds 23dBi.

OUTPUT POWER AND SPURIOUS LIMITS –UNII DEVICES

The table below shows the limits for output power and output power density defined by FCC Part 15 Subpart E. Where the signal bandwidth is less than 20 MHz the maximum output power is reduced to the power spectral density limit plus 10 times the log of the bandwidth (in MHz).

Operating Frequency (MHz)	Output Power	Power Spectral Density
5150 - 5250	50mW (17 dBm)	10 dBm/MHz
5250 - 5350	250 mW (24 dBm)	11 dBm/MHz
5470 - 5725	250 mW (24 dBm)	11 dBm/MHz
5725 – 5825	1 Watts (30 dBm)	17 dBm/MHz

The peak excursion envelope is limited to 13dB.

For system using antennas with gains exceeding 6dBi, the output power and power spectral density limits are reduced by 1dB for every dB the antenna gain exceeds 6dBi. Fixed point-to-point applications using the 5725 – 5825 MHz band may use antennas with gains of up to 23dBi without this limitation. If the gain exceeds 23dBi then the output power limit of 1 Watt is reduced by 1dB for every dB the gain exceeds 23dBi.

SAMPLE CALCULATIONS - CONDUCTED EMISSIONS

Receiver readings are compared directly to the conducted emissions specification limit (decibel form) as follows:

$$R_r - S = M$$

where:

R_r = Receiver Reading in dBuV

S = Specification Limit in dBuV

M = Margin to Specification in +/- dB

SAMPLE CALCULATIONS - RADIATED EMISSIONS

Receiver readings are compared directly to the specification limit (decibel form). The receiver internally corrects for cable loss, preamplifier gain, and antenna factor. The calculations are in the reverse direction of the actual signal flow, thus cable loss is added and the amplifier gain is subtracted. The Antenna Factor converts the voltage at the antenna coaxial connector to the field strength at the antenna elements.

A distance factor, when used for electric field measurements above 30MHz, is calculated by using the following formula:

$$F_d = 20 * \text{LOG}_{10} (D_m/D_s)$$

where:

F_d = Distance Factor in dB

D_m = Measurement Distance in meters

D_s = Specification Distance in meters

For electric field measurements below 30MHz the extrapolation factor is either determined by making measurements at multiple distances or a theoretical value is calculated using the formula:

$$F_d = 40 * \text{LOG}_{10} (D_m/D_s)$$

Measurement Distance is the distance at which the measurements were taken and Specification Distance is the distance at which the specification limits are based. The antenna factor converts the voltage at the antenna coaxial connector to the field strength at the antenna elements.

The margin of a given emission peak relative to the limit is calculated as follows:

$$R_c = R_r + F_d$$

and

$$M = R_c - L_s$$

where:

$$R_r = \text{Receiver Reading in dBuV/m}$$

$$F_d = \text{Distance Factor in dB}$$

$$R_c = \text{Corrected Reading in dBuV/m}$$

$$L_s = \text{Specification Limit in dBuV/m}$$

$$M = \text{Margin in dB Relative to Spec}$$

SAMPLE CALCULATIONS - FIELD STRENGTH TO EIRP CONVERSION

Where the radiated electric field strength is expressed in terms of the equivalent isotropic radiated power (eirp), or where a field strength measurement of output power is made in lieu of a direct measurement, the following formula is used to convert between eirp and field strength at a distance of 3m from the equipment under test:

$$E = \frac{1000000 \sqrt{30 P}}{3} \quad \text{microvolts per meter}$$

where P is the eirp (Watts)

EXHIBIT 1: Test Equipment Calibration Data

3 Pages

Radio Antenna Port (Power and Spurious Emissions), 29-May-08

Engineer: Mehran Birgani

<u>Manufacturer</u>	<u>Description</u>	<u>Model #</u>	<u>Asset #</u>	<u>Cal Due</u>
Hewlett Packard	Spectrum Analyzer 30 Hz -40 GHz, SV (SA40) Red	8564E (84125C)	1148	24-Aug-08

Radio Antenna Port (Power and Spurious Emissions), 10-Jun-08

Engineer: Mehran Birgani

<u>Manufacturer</u>	<u>Description</u>	<u>Model #</u>	<u>Asset #</u>	<u>Cal Due</u>
Hewlett Packard	SpecAn 9 kHz - 40 GHz, (SA40)	8564E	CH5273	20-Jul-08

Radio Antenna Port (Power and Spurious Emissions), 11-Jun-08

Engineer: Mehran Birgani

<u>Manufacturer</u>	<u>Description</u>	<u>Model #</u>	<u>Asset #</u>	<u>Cal Due</u>
Hewlett Packard	SpecAn 9 kHz - 40 GHz, (SA40)	8564E	CH5273	20-Jul-08

Radiated Emissions, 30 - 40,000 MHz, 15-May-08**Engineer: Mehran Birgani**

<u>Manufacturer</u>	<u>Description</u>	<u>Model #</u>	<u>Asset #</u>	<u>Cal Due</u>
EMCO	Antenna, Horn, 1-18 GHz	3115	487	24-May-08
Hewlett Packard	Microwave Preamplifier, 1-26.5GHz	8449B	870	08-Nov-08
Hewlett Packard	SpecAn 9 kHz - 40 GHz, (SA40)	8564E	CH5273	20-Jul-08

Radio Spurious Emissions,, 22-May-08**Engineer: Suhaila Khushzad**

<u>Manufacturer</u>	<u>Description</u>	<u>Model #</u>	<u>Asset #</u>	<u>Cal Due</u>
Hewlett Packard	Microwave Preamplifier, 1-26.5GHz	8449B	870	08-Nov-08
EMCO	Antenna, Horn, 1-18 GHz (SA40-Blu)	3115	1386	11-Jul-08

Radio Spurious Emissions, 27-May-08**Engineer: Suhaila Khushzad**

<u>Manufacturer</u>	<u>Description</u>	<u>Model #</u>	<u>Asset #</u>	<u>Cal Due</u>
Hewlett Packard	Microwave Preamplifier, 1-26.5GHz	8449B	870	08-Nov-08
EMCO	Antenna, Horn, 1-18 GHz (SA40-Blu)	3115	1386	11-Jul-08
Hewlett Packard	SpecAn 9 kHz - 40 GHz, (SA40) Purple	8564E (84125C)	Rental	17-Dec-08

Radio Spurious Emissions, 28-May-08**Engineer: Suhaila Khushzad**

<u>Manufacturer</u>	<u>Description</u>	<u>Model #</u>	<u>Asset #</u>	<u>Cal Due</u>
Hewlett Packard	Microwave Preamplifier, 1-26.5GHz	8449B	870	08-Nov-08
Hewlett Packard	Spectrum Analyzer 30 Hz -40 GHz, SV (SA40) Red	8564E (84125C)	1148	24-Aug-08
EMCO	Antenna, Horn, 1-18 GHz (SA40-Blu)	3115	1386	11-Jul-08

Conducted Emissions - AC Power and Telecommunications Ports, 03-Jun-08**Engineer: Chris Groat**

<u>Manufacturer</u>	<u>Description</u>	<u>Model #</u>	<u>Asset #</u>	<u>Cal Due</u>
Elliott Laboratories	LISN, FCC / CISPR	LISN-3, OATS	304	18-Jul-08
Rohde & Schwarz	Test Receiver, 9 kHz-2750 MHz	ESCS 30	1337	21-Sep-08
Rohde& Schwarz	Pulse Limiter	ESH3 Z2	1398	12-Feb-09
Fischer Custom Comm.	FCC-TLISN-T8-02 (Includes 1907)	FCC-TLISN-T8-02	1906	05-Jul-08
Hewlett Packard	SpecAn 9 kHz - 40 GHz, (SA40)	8564E	CH5273	20-Jul-08

EXHIBIT 2: Test Measurement Data

T71644 – RF Port Measurements (Power, PSD etc)	61 Pages
T71642 – Transmitter Radiated Emissions	19 Pages
T71645 – AC Conducted Emissions	9 Pages



EMC Test Data

Client:	Xirrus	Job Number:	J71456
Model:	XN16 and XN8	T-Log Number:	T71644
		Account Manager:	Susan Pelzl
Contact:	Steve Smith		Mark Briggs
Emissions Standard(s):	-	Class:	-
Immunity Standard(s):	-	Environment:	-

EMC Test Data

For The

Xirrus

Model

XN16 and XN8

Date of Last Test: 6/11/2008

Client: Xirrus

Job Number: J71456

Model: XN16 and XN8

T-Log Number: T71644

Account Manager: Susan Pelzi

RSS 210 and FCC 15E Power Measurement Summary

5150 - 5250 MHz Band

There are four non-overlapping 20MHz channels and two 40MHz non-overlapping channels. The power measurements below cover the cases where there is only one radio operational in the band and where there are the maximum number of radios (4x20MHz channel or 2x40MHz channel) operating in the band. When more than one channel is being used in the band the output power per radio has to be reduced. The power measurements include power levels for one radio and for the maximum number of radios operational in the band.

802.11a - single chain

Power Setting ²	Frequency (MHz)	Output Power		Antenna Gain (dBi)	EIRP ^{Note 2}		
		(dBm) ¹	mW		dBm	W	
17.5	5180	16.2	41.7	6.0	22.2	0.166	
17.0	5200	15.9	38.5	6.0	21.9	0.153	
17.0	5220	Not measured - max will be 16.3dBm					
17.0	5240	16.3	42.7	6.0	22.3	0.170	

Limit is 17dBm

Power setting for all four channels being used:

12.0	5180	10.5	11.3	6.0	16.5	0.045
12.0	5200	11.0	12.4	6.0	17.0	0.050
11.5	5220	10.8	12.0	6.0	16.8	0.048
11.0	5240	10.5	11.3	6.0	16.5	0.045
Power 4x802.11a 20MHz channels:		16.7	47.1	6.0	22.7	0.187

802.11a - dual chain (EIRP assumes coherency between chains, effective antenna gain is x2 = 9dBi)

Frequency (MHz)	Software Setting	Output Power (dBm)				Antenna Gain (dBi)	EIRP ^{Note 2}		
		A	B	C	Total		dBm	W	
5180	12.0	10.7		8.9	12.9	9.0	21.9	0.155	
5200	11.5	10.8		9.0	13.0	9.0	22.0	0.159	
5220		Not measured - max will be 13.3dBm total across both chains							
5240	11.5	11.3		9.1	13.3	9.0	22.3	0.172	

Limit is 14dBm

Power setting for all four channels being used:

5180	6.5	5.5		3.4	7.6	9.0	16.6	0.046
5200	6.0	5.3		3.2	7.4	9.0	16.4	0.044
5220	6.0	5.7		3.4	7.7	9.0	16.7	0.047
5240	6.0	6.1		3.3	8.0	9.0	17.0	0.050
Total power with four 802.11a MIMO 20MHz channels in use:					13.7	9.0	22.7	0.186

Limit is 14dBm

Client: Xirrus

Job Number: J71456

Model: XN16 and XN8

T-Log Number: T71644

Account Manager: Susan Pelzi

802.11n 20MHz - dual chain (EIRP assumes no coherency between chains, effective antenna gain is x1)

Frequency (MHz)	Software Setting	Output Power (dBm)				Antenna Gain (dBi)	EIRP ^{Note 2}		Limit is 17dBm
		A	B	C	Total		dBm	W	
5180	15.0	14.4		12.9	16.7	6.0	22.7	0.186	
5200	14.5	13.8		12.9	16.3	6.0	22.3	0.171	
5220		Not measured - max will be 16.7dBm							
5240	15.0	13.7		13.7	16.7	6.0	22.7	0.186	

Power setting for all four channels being used (11dBm per radio):

5180	6.5	8.5		6.8	10.8	6.0	16.8	0.047	Limit is 17dBm
5200	6.0	8.5		7.4	11.0	6.0	17.0	0.050	
5220	6.0	8.4		7.1	10.8	6.0	16.8	0.048	
5240	6.0	8.3		7.9	11.1	6.0	17.1	0.051	
Total power with four 802.11 20MHz channels in use:					16.9	6.0	22.9	0.197	

802.11n 40MHz - dual chain (EIRP assumes no coherency between chains, effective antenna gain is x1)

Frequency (MHz)	Software Setting	Output Power (dBm)				Antenna Gain (dBi)	EIRP ^{Note 2}		Limit is 17dBm
		A	B	C	Total		dBm	W	
5190	9.0	8.8		7.2	11.1	6.0	17.1	0.051	
5230	15.0	14.0		13.5	16.7	6.0	22.7	0.187	

Power setting for both channels being used:

5180	9.0	8.8		7.2	11.1	6.0	17.1	0.051	Limit is 17dBm
5240	13.0	12.2		12.2	15.2	6.0	21.2	0.132	
Total power with two 802.11 40Mhz channels in use:					16.6	6.0	22.6	0.183	

Client: Xirrus	Job Number: J71456
Model: XN16 and XN8	T-Log Number: T71644
	Account Manager: Susan Pezli
Contact: Steve Smith	
Standard: -	Class: N/A

**RSS-210 (LELAN) and FCC 15.407(UNII)
Antenna Port Measurements
Power, PSD, Peak Excursion, Bandwidth and Spurious Emissions**

Test Specific Details

Objective: The objective of this test session is to perform final qualification testing of the EUT with respect to the specification listed above.

Date of Test: 5/29/2008
Test Engineer: Mehran Birgani
Test Location: SVOATS # 2

Config. Used: -
Config Change: Direct connection
EUT Voltage: 120V/60Hz

General Test Configuration

When measuring the conducted emissions from the EUT's antenna port, the antenna port of the EUT was connected to the spectrum analyzer or power meter via a suitable attenuator to prevent overloading the measurement system. All measurements are corrected to allow for the external attenuators and cables used.

Ambient Conditions:

Temperature: 19 °C
Rel. Humidity: 48 %

Summary of Results

Run #	Test Performed	Limit	Pass / Fail	Result / Margin
1	Power, 5150 - 5250MHz	15.407(a) (1), (2)	Pass	16.3 dBm (43mW)
1	PSD, 5150 - 5250MHz	15.407(a) (1), (2)	Pass	3.9 dBm/MHz
1	26dB Bandwidth	15.407	-	26.6 MHz
1	99% Bandwidth	RSS 210	-	16.9 MHz
2	Peak Excursion Envelope	15.407(a) (6)	Pass	11.9 dBm
3	Antenna Conducted - Out of Band Spurious	15.407(b)	Pass	All emissions below the -27dBm/MHz limit

Modifications Made During Testing

No modifications were made to the EUT during testing

Deviations From The Standard

No deviations were made from the requirements of the standard.

Client: Xirrus	Job Number: J71456
Model: XN16 and XN8	T-Log Number: T71644
	Account Manager: Susan Pezli
Contact: Steve Smith	
Standard: -	Class: N/A

Run #1: Bandwidth, Output Power and Power spectral Density

Antenna gain used is for the internal antenna. The external antenna gain is lower (2.5dBi) and not used for MIMO modes.

Antenna Gain (dBi): **6.0**

Power settings for a single radio operating in the band

Frequency (MHz)	Software Setting	Bandwidth		Output Power ¹ dBm		Power (Watts)	PSD ² dBm/MHz			Result
		26dB	99% ⁴	Measured	Limit		Measured	FCC Limit	RSS Limit ³	
5180	17.5	25.8	16.9	16.2	17.0	0.042	3.9	4.0	4.0	Pass
5200	17.0	25.5	16.9	15.9	17.0	0.038	3.3	4.0	4.0	Pass
5240	17.0	26.6	16.9	16.3	17.0	0.043	3.9	4.0	4.0	Pass

Power settings for all four channels being used in the band
Set power to 11dBm per chain

Frequency (MHz)	Software Setting	Bandwidth		Measured Power ¹		Limit
		26dB	99% ⁴	dBm	mW	
5180	12.0	25.3	16.8	10.5	11.3	Limit
5200	12.0	25.6	16.9	11.0	12.4	
5220	11.5	25.4	16.9	10.8	12.0	
5240	11.0	25.8	16.9	10.5	11.3	
Total Power Across The Band				16.7	47.1	17 dBm

Only power was measured - aggregation of PSD is not applicable as the device cannot have more than one radio operating on a channel.

Note 1:	Output power measured using a spectrum analyzer (see plots below): RBW=1MHz, VB=3 MHz, sample detector, power averaging on (transmitted signal was continuous) and power integration over 50 MHz
Note 2:	Measured using the same analyzer settings used for output power.
Note 3:	For RSS-210 the limit for the 5150 - 5250 MHz band accounts for the antenna gain as the maximum eirp allowed is 10dBm/MHz. The limits are also corrected for instances where the highest measured value of the PSD exceeds the average PSD (calculated from the measured power divided by the measured 99% bandwidth) by more than 3dB by the amount that the measured value exceeds the average by more than 3dB.
Note 4:	99% Bandwidth measured in accordance with RSS GEN - RB > 1% of span and VB >=3xRB

Client: Xirrus	Job Number: J71456
Model: XN16 and XN8	T-Log Number: T71644
Contact: Steve Smith	Account Manager: Susan Pezli
Standard: -	Class: N/A

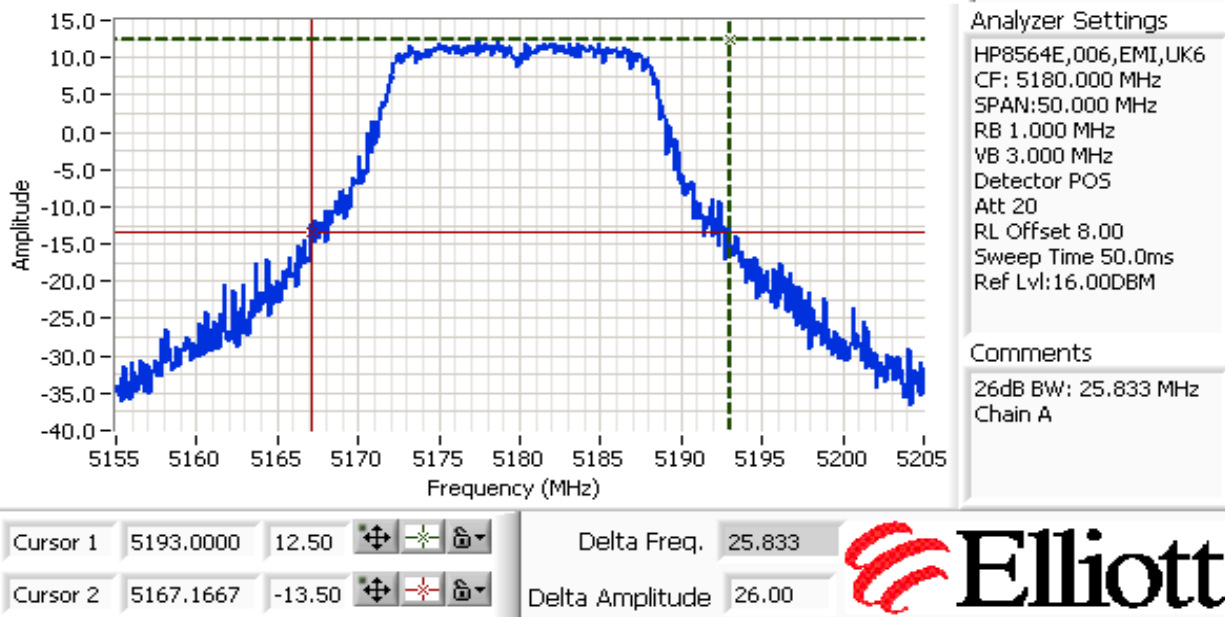
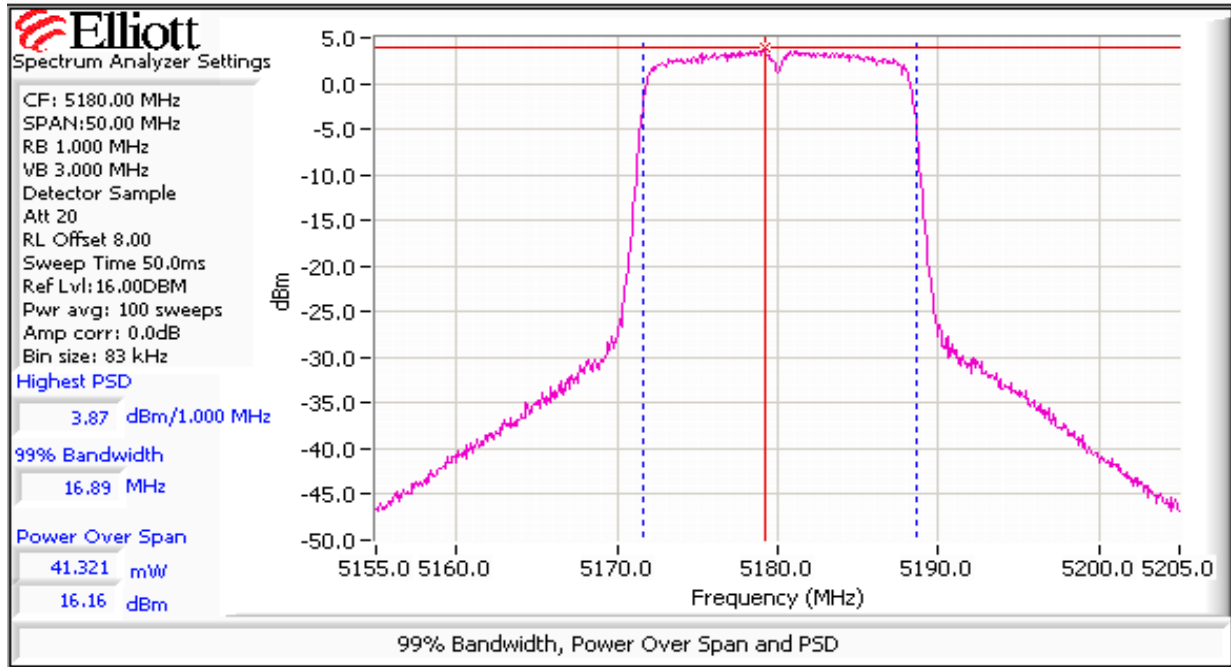

Client: Xirrus	Job Number: J71456
Model: XN16 and XN8	T-Log Number: T71644
Contact: Steve Smith	Account Manager: Susan Pezli
Standard: -	Class: N/A

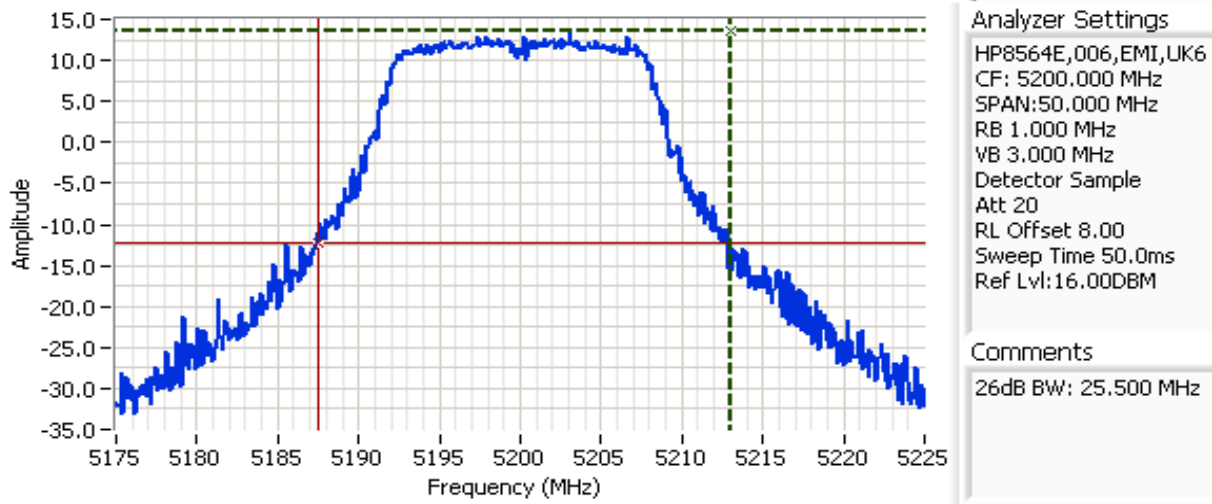
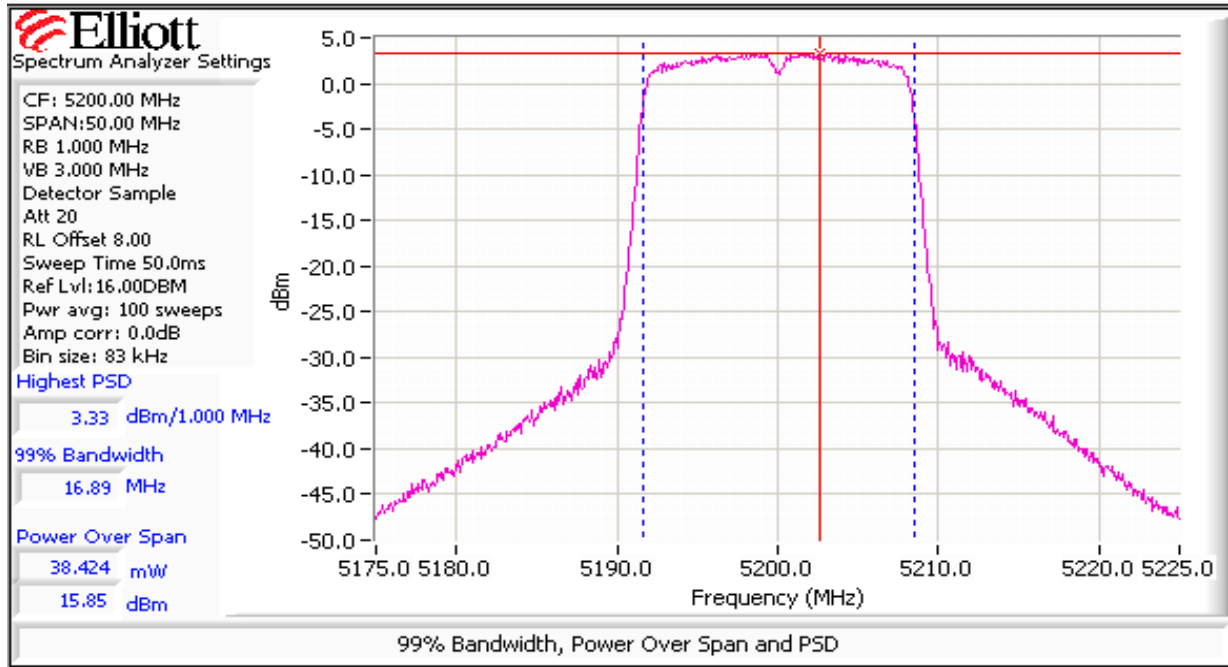

Cursor 1	5213.0000	13.67	↕	✳	🔒
Cursor 2	5187.5000	-12.33	↕	✳	🔒

Delta Freq. 25.500
Delta Amplitude 26.00

Client: Xirrus	Job Number: J71456
Model: XN16 and XN8	T-Log Number: T71644
Contact: Steve Smith	Account Manager: Susan Pezli
Standard: -	Class: N/A

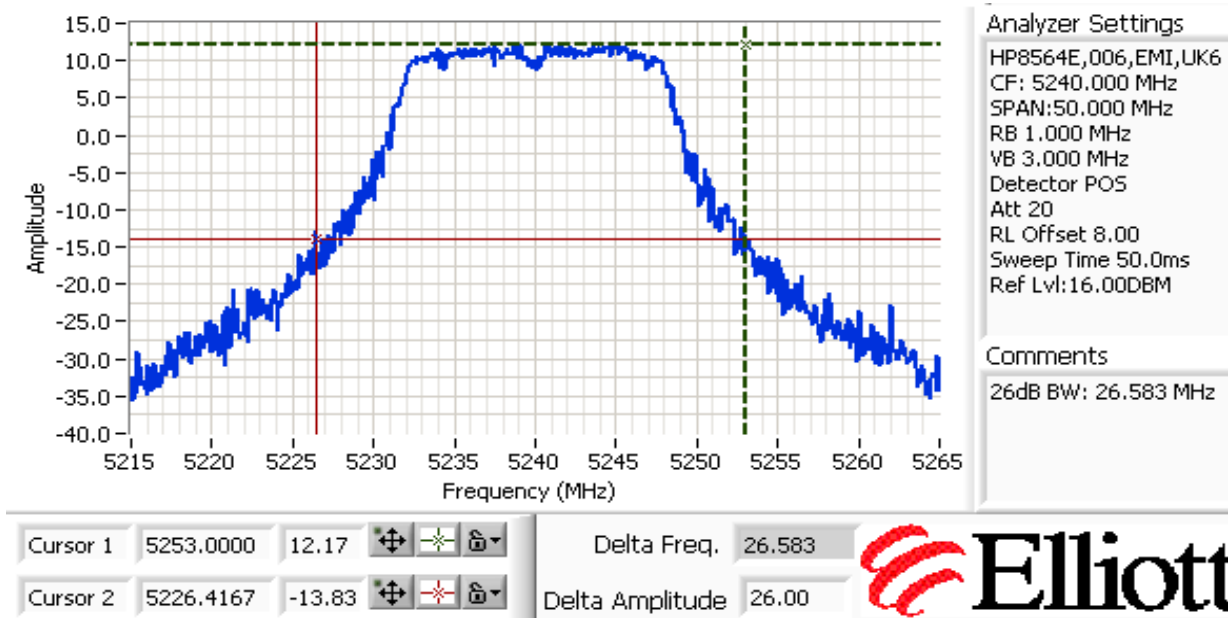
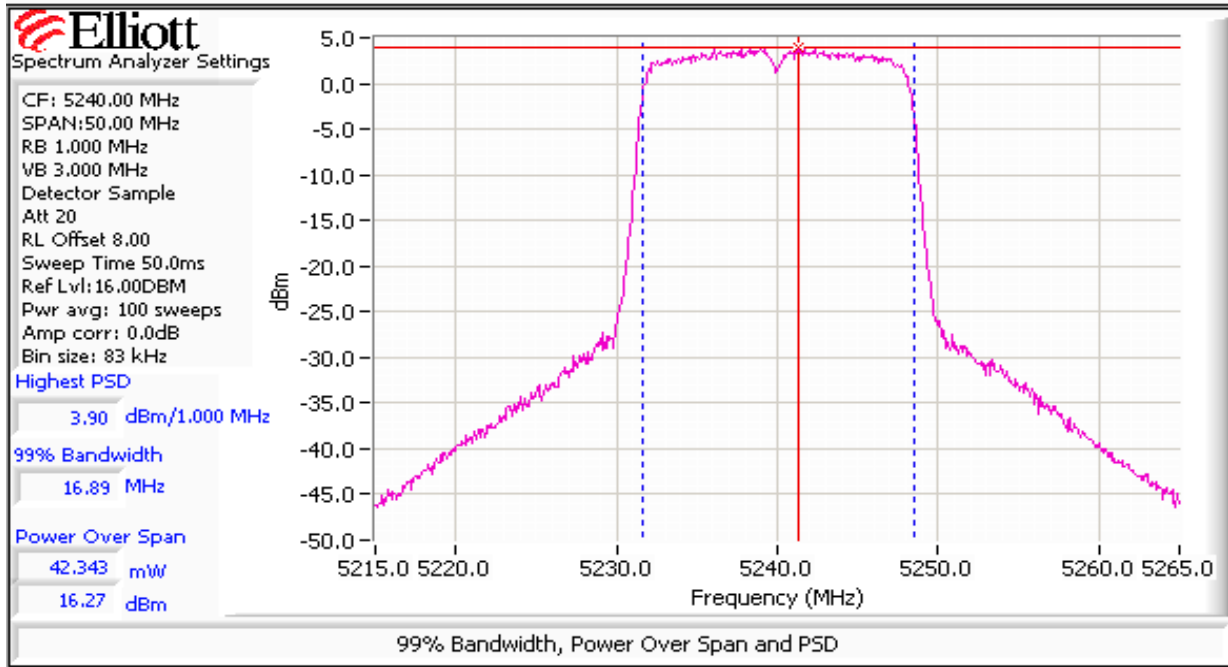

Client: Xirrus	Job Number: J71456
Model: XN16 and XN8	T-Log Number: T71644
Contact: Steve Smith	Account Manager: Susan Pezli
Standard: -	Class: N/A

Run #2: Peak Excursion Measurement

Device meets the requirement for the peak excursion

Freq (MHz)	Peak Excursion(dB) Value	Peak Excursion(dB) Limit	Freq (MHz)	Peak Excursion(dB) Value	Peak Excursion(dB) Limit	Freq (MHz)	Peak Excursion(dB) Value	Peak Excursion(dB) Limit
5180	11.9	13.0	5260		13.0	5500		13.0
5200	11.3	13.0	5300		13.0	5600		13.0
5240	11.5	13.0	5320		13.0	5700		13.0

Plots Showing Peak Excursion

Trace A: RBW = VBW = 3MHz, Peak hold
Trace B: RBW = 1 MHz, VBW = 3MHz, Integrated average power

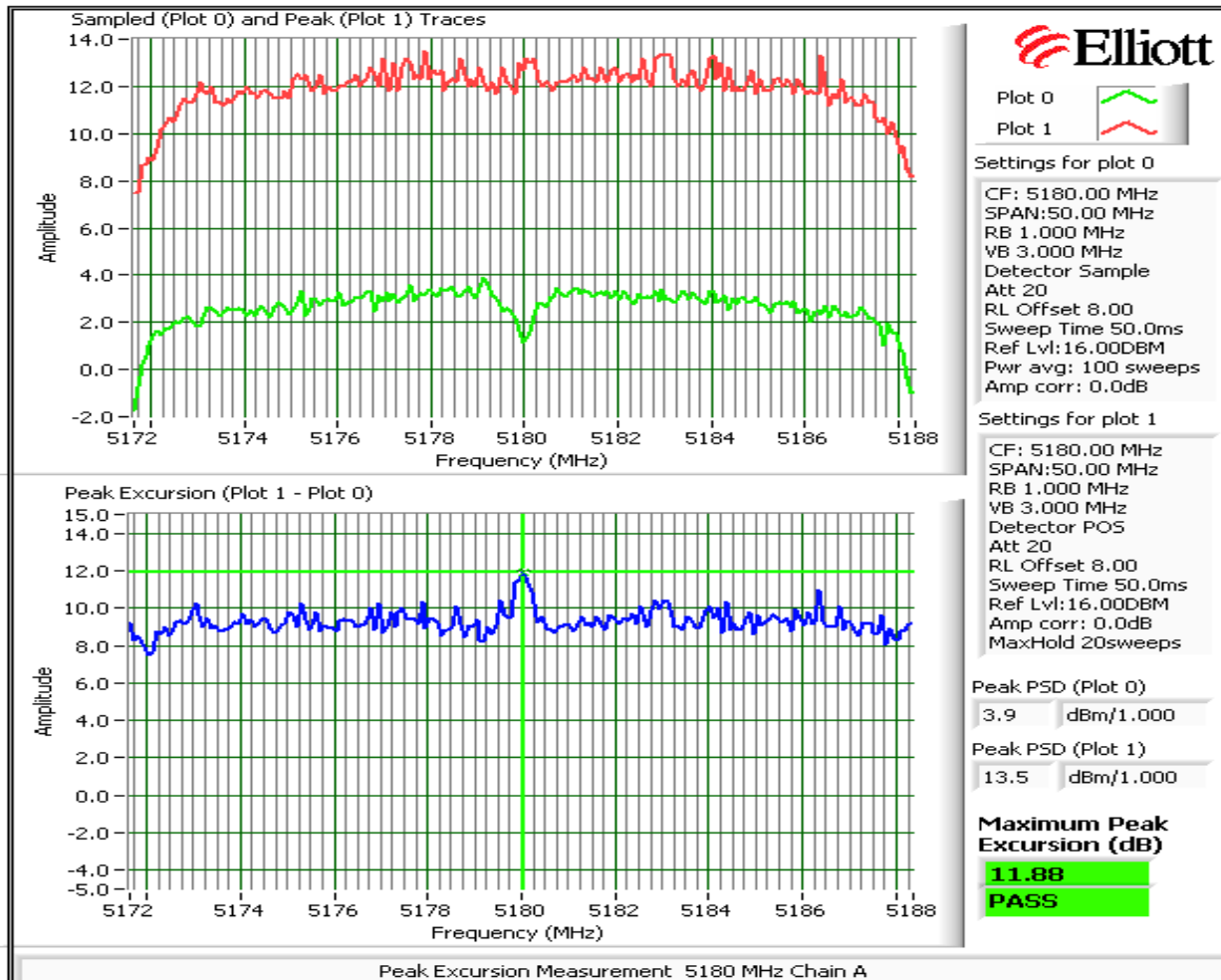

Client: Xirrus	Job Number: J71456
Model: XN16 and XN8	T-Log Number: T71644
	Account Manager: Susan Pezli
Contact: Steve Smith	
Standard: -	Class: N/A

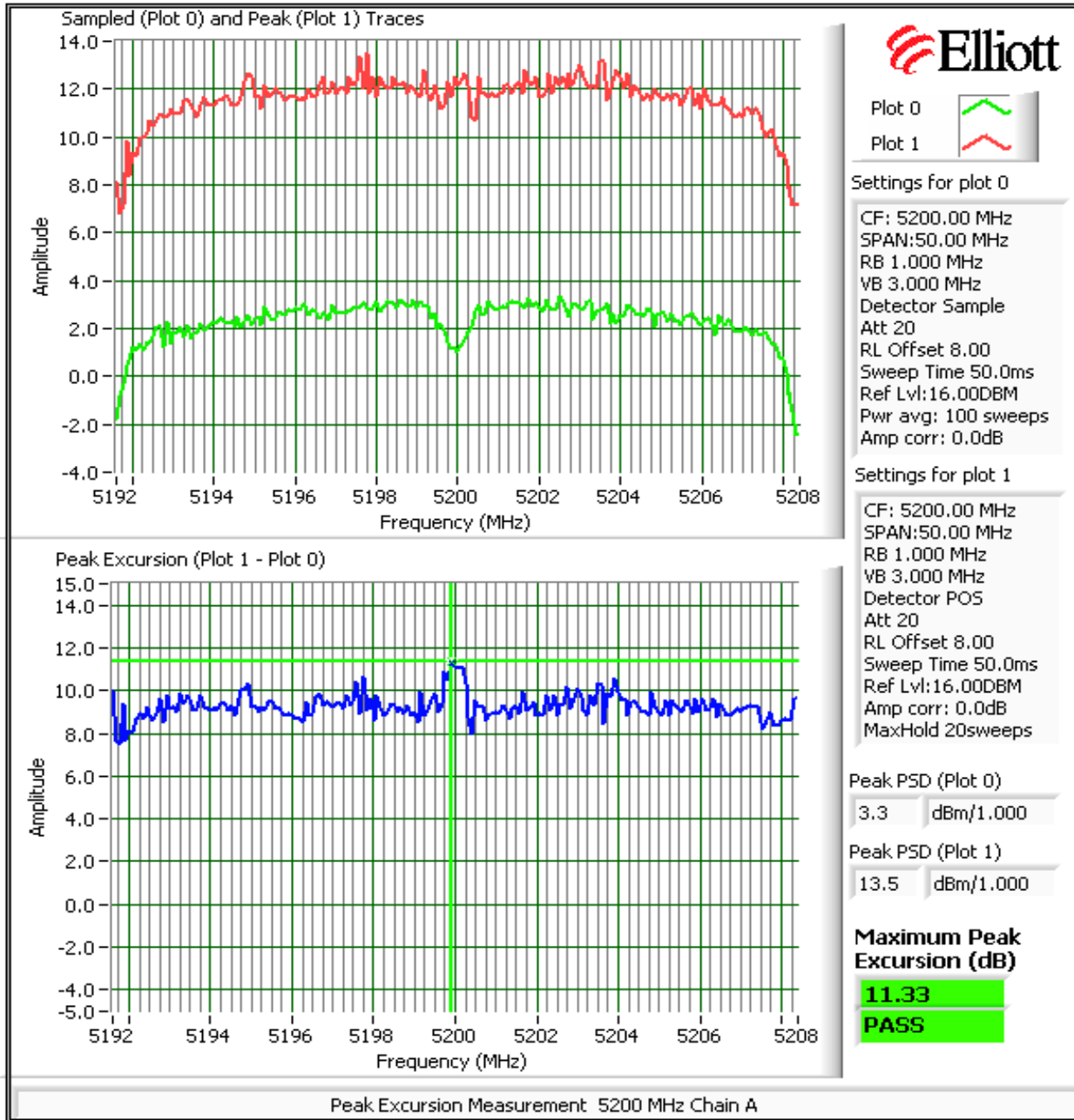

Client: Xirrus	Job Number: J71456
Model: XN16 and XN8	T-Log Number: T71644
Contact: Steve Smith	Account Manager: Susan Pezli
Standard: -	Class: N/A

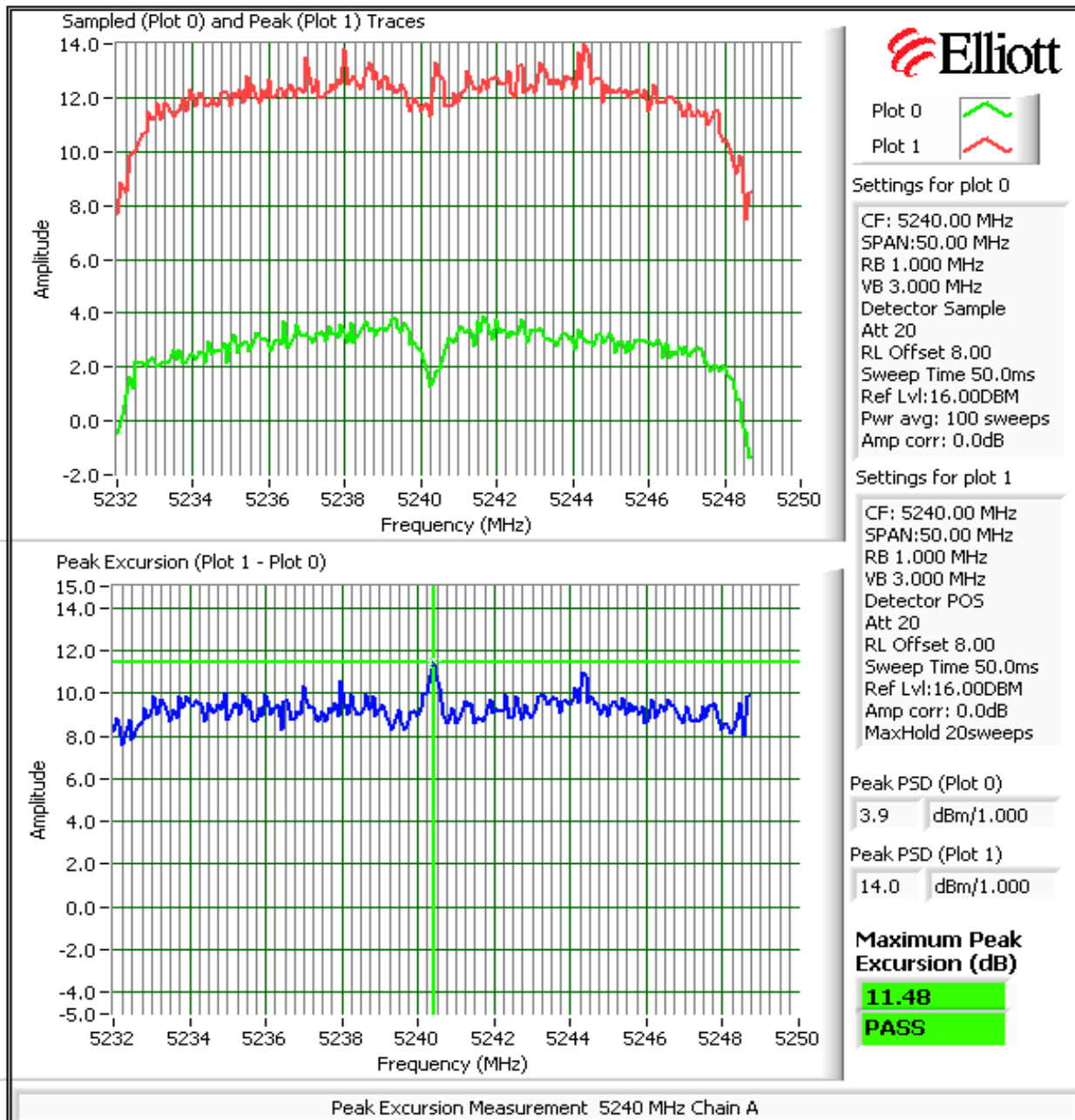

Client: Xirrus	Job Number: J71456
Model: XN16 and XN8	T-Log Number: T71644
	Account Manager: Susan Pelzi
Contact: Steve Smith	
Standard: -	Class: N/A

Run #3: Out Of Band Spurious Emissions - Antenna Conducted

MIMO Devices: As the output power setting for the single chain mode is higher than the setting for dual chain, and by adjusting the limit for out of band spurious emissions to account for dual chain operation, the plots below cover both single- and dual chain operation.

Number of transmit chains:	2
Maximum Antenna Gain:	9.0 dBi
Spurious Limit:	-27.0 dBm/MHz eirp
Adjustment for 2 chains:	-6.0 dB adjustment for multiple chains and coherency between chains.
Limit Used On Plots ^{Note 1} :	-42.0 dBm/MHz Average Limit (RB=1MHz, VB=10Hz)
	-22.0 dBm/MHz Peak Limit (RB=VB=1MHz)

Note 1:	The -27dBm/MHz limit is an eirp limit. The limit for antenna port conducted measurements is adjusted to take into consideration the maximum antenna gain (limit = -27dBm - antenna gain). Radiated field strength measurements for signals more than 50MHz from the bands and that are close to the limit are made to determine compliance as the antenna gain is not known at these frequencies.
Note 2:	All spurious signals below 1GHz are measured during digital device radiated emissions test.
Note 3:	Signals within 10MHz of the 5.725 or 5.825 Band edge are subject to a limit of -17dBm EIRP
Note 4:	If the device is for outdoor use then the -27dBm eirp limit also applies in the 5150 - 5250 MHz band.
Note 5:	Signals that fall in the restricted bands of 15.205 are subject to the limit of 15.209.

Plots Showing Out-Of-Band Emissions (RBW=VBW=1MHz)

Low channel, 5150 - 5250 MHz Band

Compliance with the radiated limits for the restricted band immediately below 5150MHz is demonstrated through the radiated emissions tests.

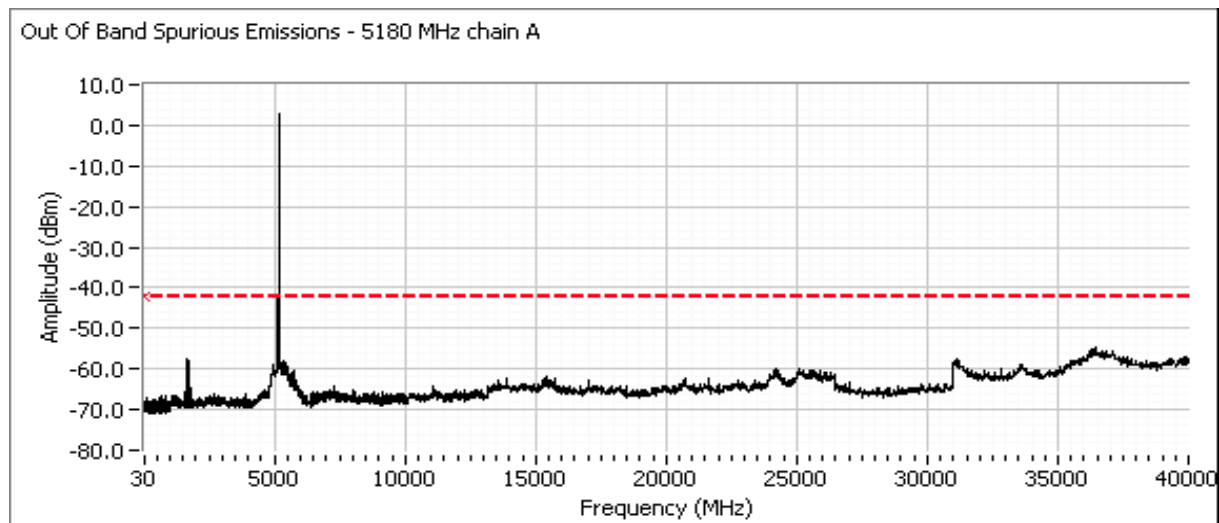

Client: Xirrus	Job Number: J71456
Model: XN16 and XN8	T-Log Number: T71644
	Account Manager: Susan Pezli
Contact: Steve Smith	
Standard: -	Class: N/A

Out Of Band Spurious Emissions - 5180 MHz chain A (Average)

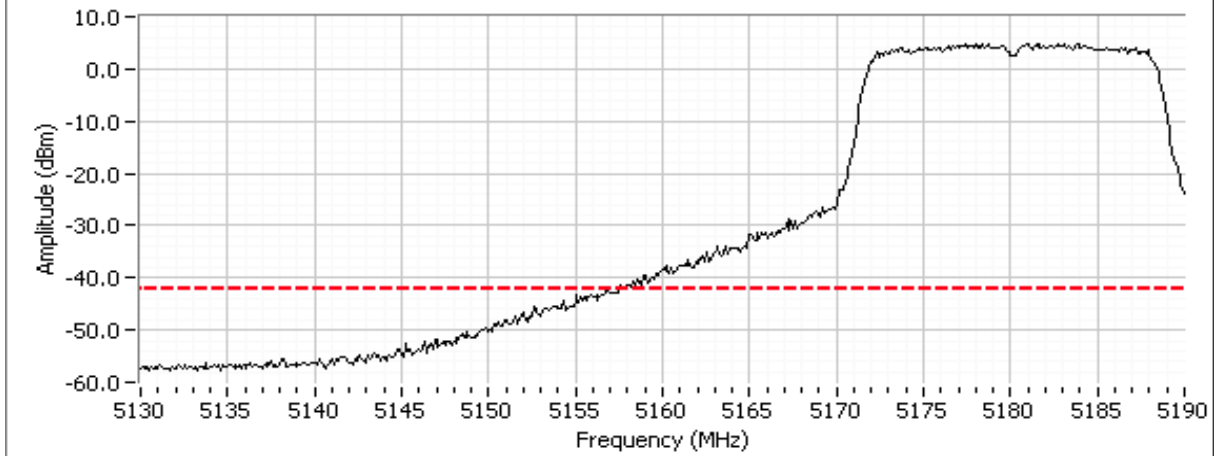

Out Of Band Spurious Emissions - 5180 MHz chain A (Peak)

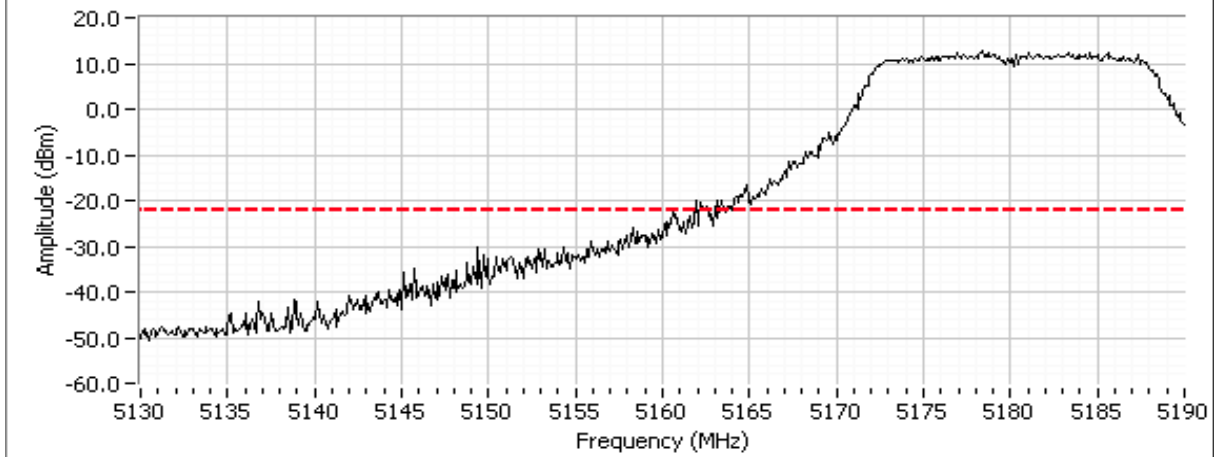

Client: Xirrus	Job Number: J71456
Model: XN16 and XN8	T-Log Number: T71644
Contact: Steve Smith	Account Manager: Susan Pezli
Standard: -	Class: N/A

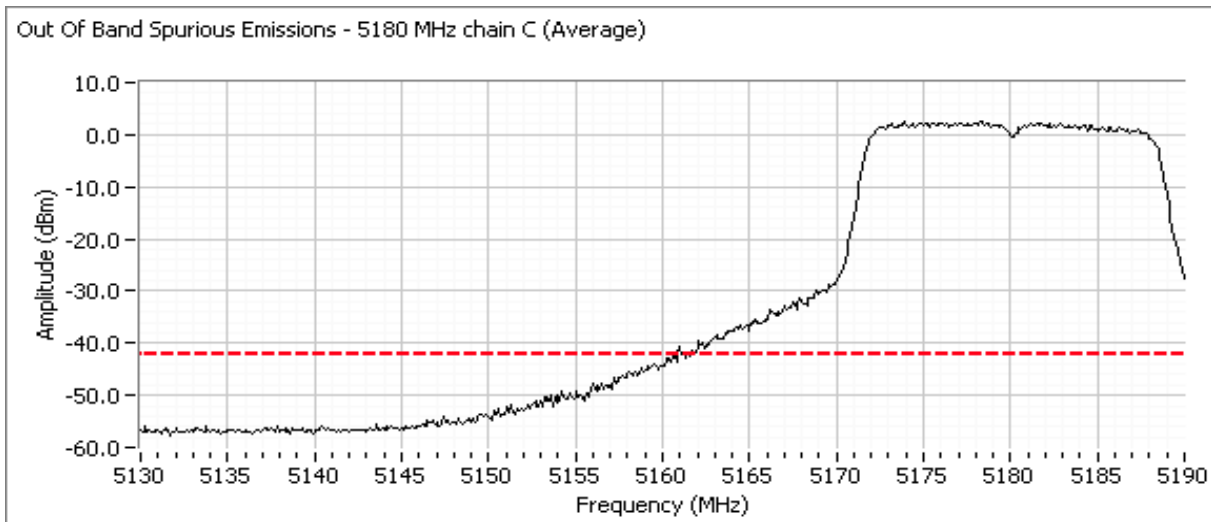
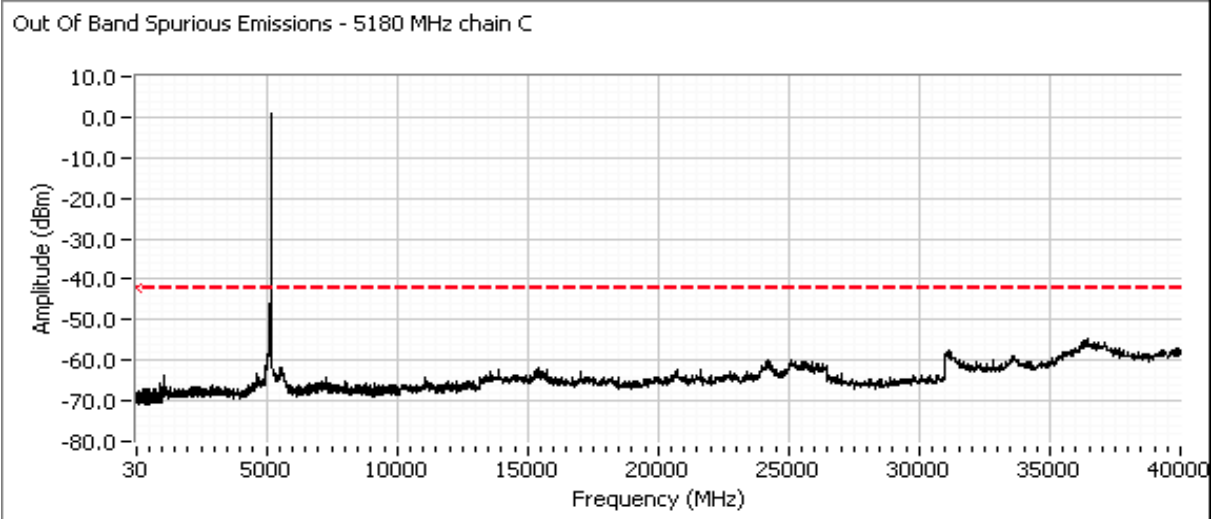

Client: Xirrus	Job Number: J71456
Model: XN16 and XN8	T-Log Number: T71644
	Account Manager: Susan Pelzi
Contact: Steve Smith	
Standard: -	Class: N/A

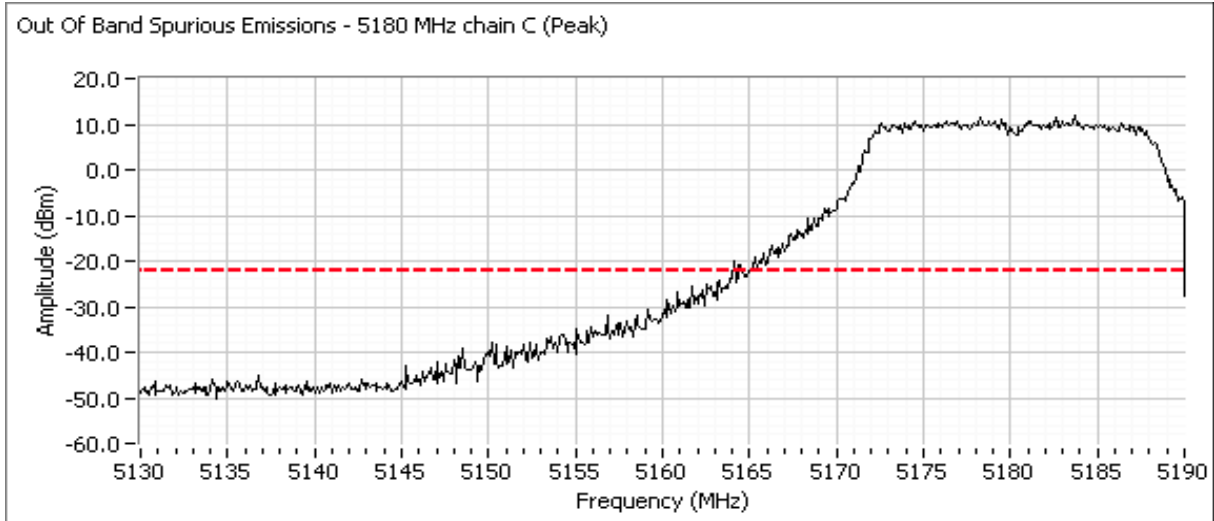

Client: Xirrus	Job Number: J71456
Model: XN16 and XN8	T-Log Number: T71644
	Account Manager: Susan Pezli
Contact: Steve Smith	
Standard: -	Class: N/A

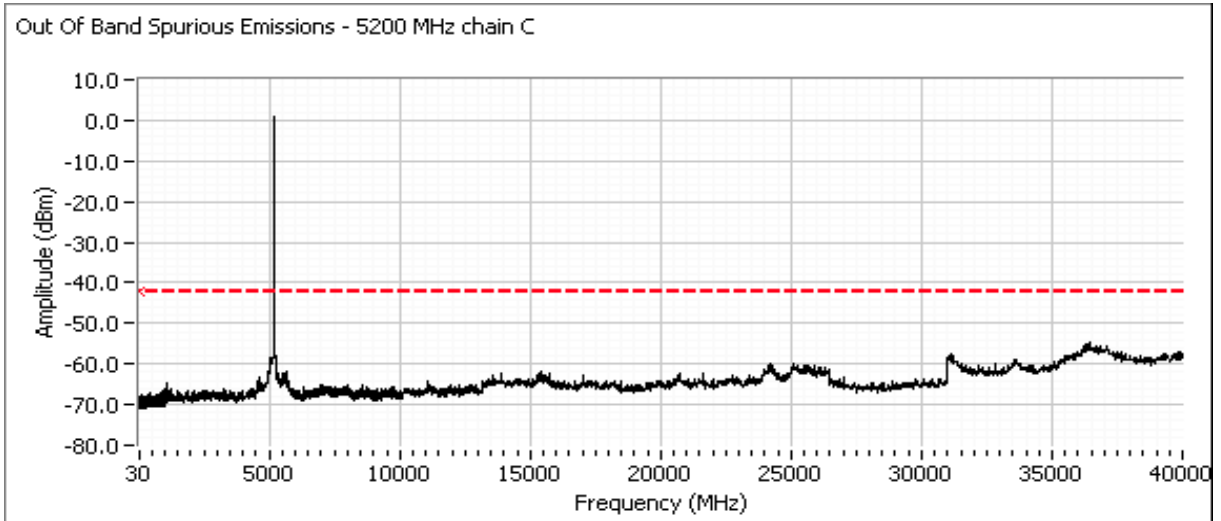
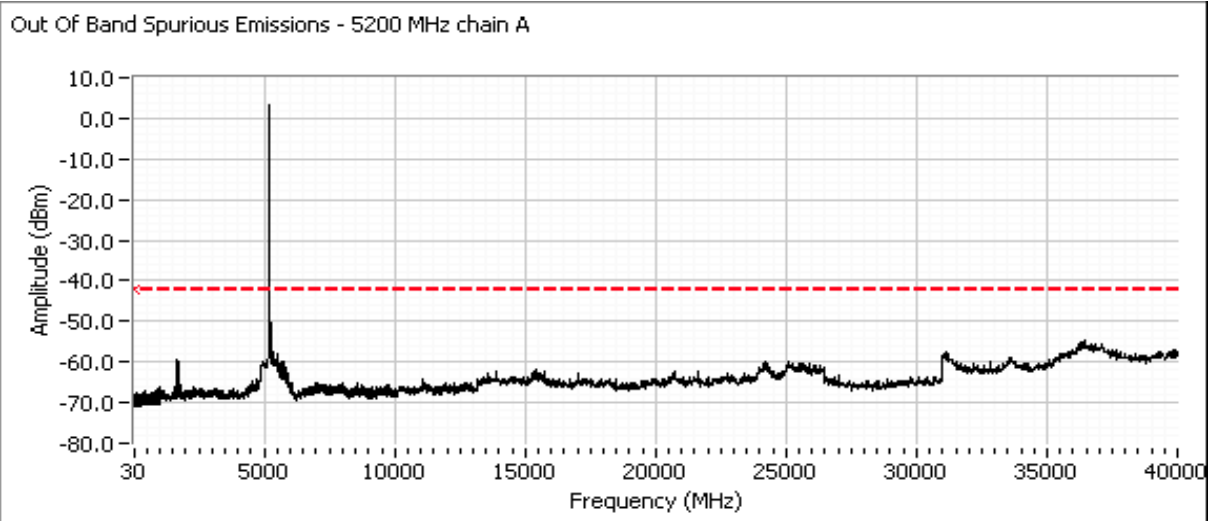
Center channel, 5150 - 5250 MHz Band

Client: Xirrus	Job Number: J71456
Model: XN16 and XN8	T-Log Number: T71644
	Account Manager: Susan Pezli
Contact: Steve Smith	
Standard: -	Class: N/A

High channel, 5150 - 5250 MHz Band

Note; Initial approval for FCC will only allow operation in the 5150 - 5250 MHz NII band so a plot showing -20dBc at 5250 MHz and above is included.

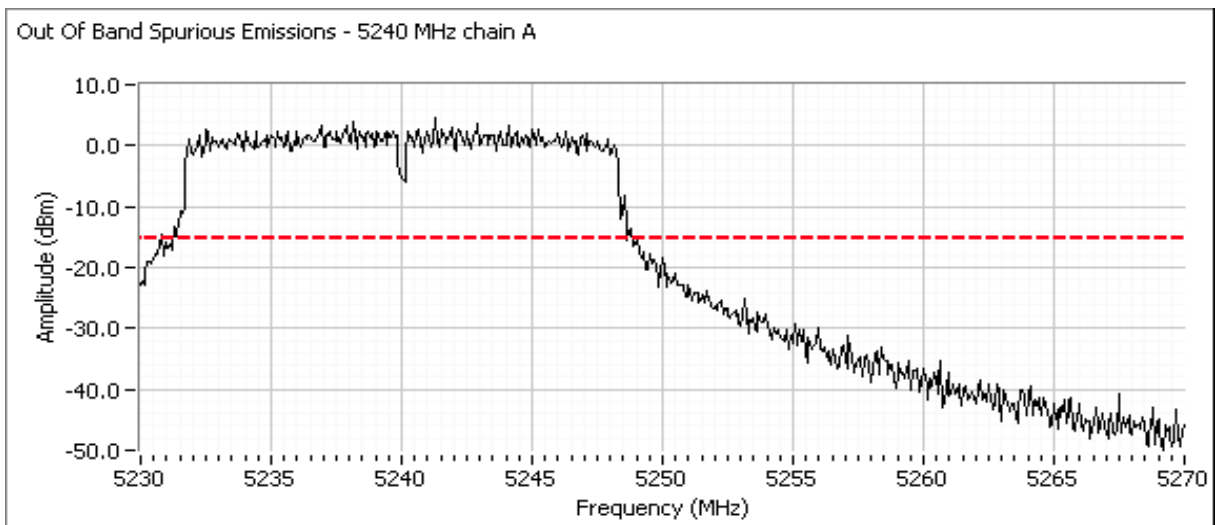
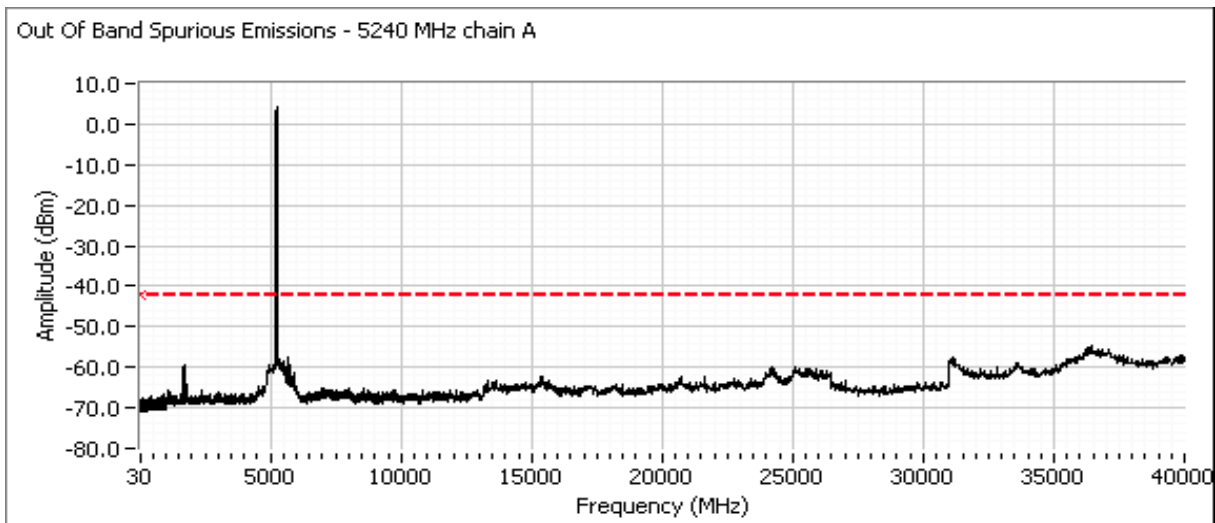

Client: Xirrus	Job Number: J71456
Model: XN16 and XN8	T-Log Number: T71644
Contact: Steve Smith	Account Manager: Susan Pezli
Standard: -	Class: N/A

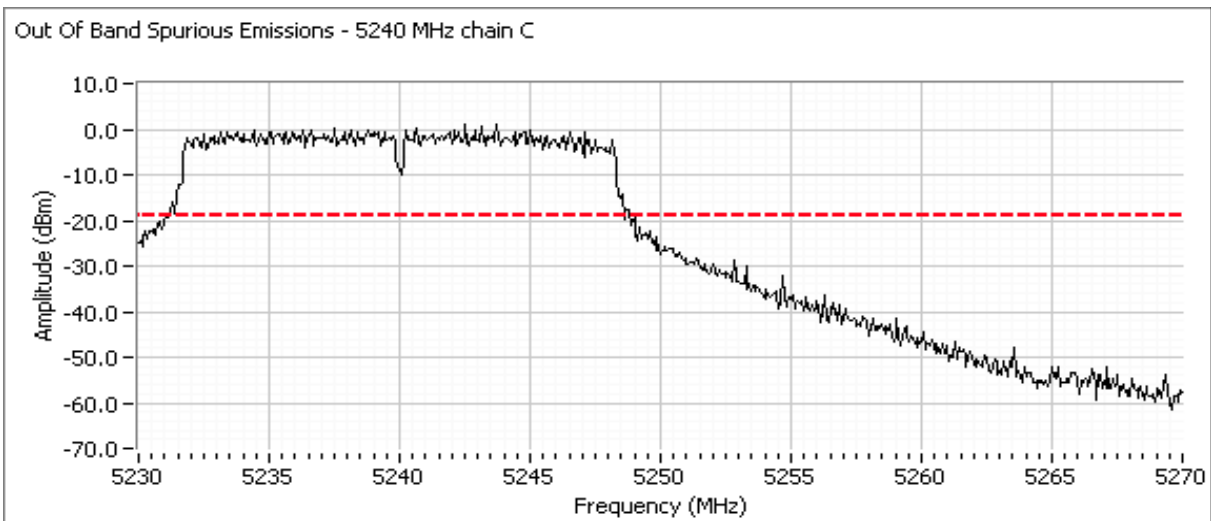
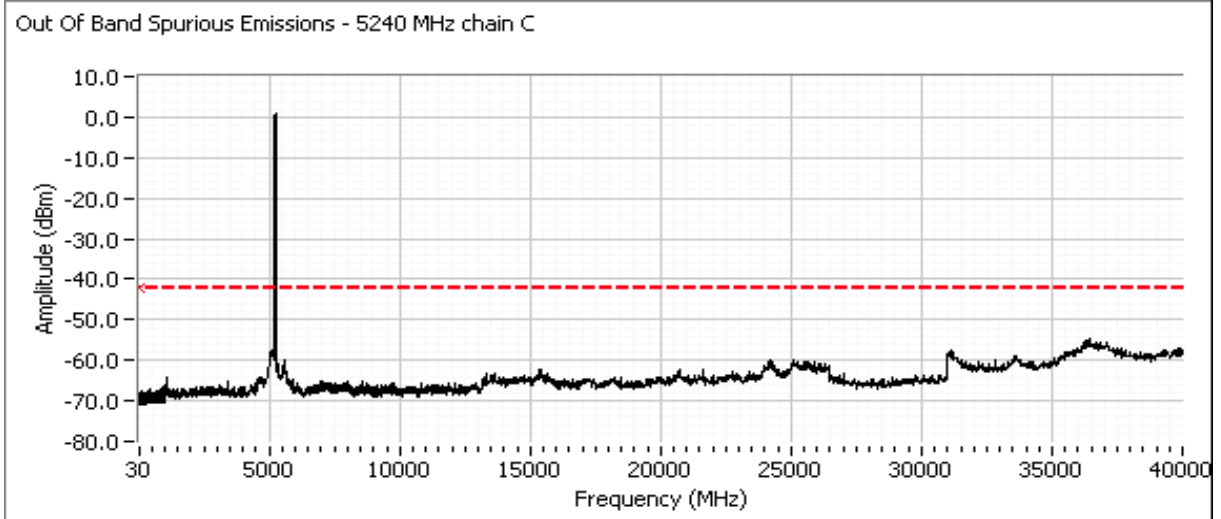

Client: Xirrus	Job Number: J71456
Model: XN16 and XN8	T-Log Number: T71644
	Account Manager: Susan Pezli
Contact: Steve Smith	
Standard: -	Class: N/A

RSS-210 (LELAN) and FCC 15.407(UNII)
Antenna Port Measurements
Power, PSD, Peak Excursion, Bandwidth and Spurious Emissions

Test Specific Details

Objective: The objective of this test session is to perform final qualification testing of the EUT with respect to the specification listed above.

Date of Test: 5/29/2008
 Test Engineer: Mehran Birgani
 Test Location: SVOATS # 2

Config. Used: -
 Config Change: Direct connection
 EUT Voltage: 120V/60Hz

General Test Configuration

When measuring the conducted emissions from the EUT's antenna port, the antenna port of the EUT was connected to the spectrum analyzer or power meter via a suitable attenuator to prevent overloading the measurement system. All measurements are corrected to allow for the external attenuators and cables used.

Ambient Conditions:

Temperature: 18 °C
 Rel. Humidity: 48 %

Summary of Results

Run #	Test Performed	Limit	Pass / Fail	Result / Margin
1	Power, 5150 - 5250MHz	15.407(a) (1), (2)	Pass	13.3 dBm (21.6 mW)
1	PSD, 5150 - 5250MHz	15.407(a) (1), (2)	Pass	0.9 dBm/MHz
1	26dB Bandwidth	15.407	-	25.4 MHz
1	99% Bandwidth	RSS 210	-	16.9 MHz
2	Peak Excursion Envelope	15.407(a) (6)	Pass	12.5 dB
3	Antenna Conducted Out of Band Spurious	15.407(b)		Covered by single-chain mode measurements

Modifications Made During Testing

No modifications were made to the EUT during testing

Deviations From The Standard

No deviations were made from the requirements of the standard.

Client: Xirrus	Job Number: J71456
Model: XN16 and XN8	T-Log Number: T71644
	Account Manager: Susan Pezli
Contact: Steve Smith	
Standard: -	Class: N/A

Run #1: Bandwidth, Output Power and Power spectral Density

Antenna gain used is for the internal antenna. The external antenna gain is lower (2.5dBi) and not used for MIMO modes.

	Chain 1	Chain 2	Chain 3	Coherent	Effective ⁵
Antenna Gain (dBi):	6		6	Yes	9.0

Power settings for a single radio operating in the band

Set output power to as close to 17dB as possible for the middle/high channel - use band edge powers for bottom channel

Frequency (MHz)	Software Setting	26dB BW (MHz)	Measured Output Power ¹ dBm			Total		Limit (dBm)	Max Power (W)	Pass or Fail
			Chain 1	Chain 2	Chain 3	mW	dBm			
5180	12.0	24.6	10.7		8.9	19.5	12.9	14.0	0.022	PASS
5200	11.5	25.3	10.8		9.0	20.0	13.0			PASS
5240	11.5	25.4	11.3		9.1	21.6	13.3			PASS

Frequency (MHz)	99% ⁴ BW	Total Power	PSD ² dBm/MHz			Total PSD		Limit		Pass or Fail
			Chain 1	Chain 2	Chain 3	mW/MHz	dBm/MHz	FCC	RSS 210 ³	
5180	16.9	12.9	-1.7		-3.6	1.1	0.5	1.0	1.0	PASS
5200	16.9	13.0	-1.6		-3.4	1.1	0.6	1.0	1.0	PASS
5240	16.9	13.3	-1.1		-3.5	1.2	0.9	1.0	1.0	PASS

Note 1:	Output power measured using a spectrum analyzer (see plots below for the high power measurements): RBW=1MHz, VB=3 MHz, sample detector, power averaging on (transmitted signal was continuous) and power integration over 50MHz.
Note 2:	Measured using the same analyzer settings used for output power.
Note 3:	For RSS-210 the limit for the 5150 - 5250 MHz band accounts for the antenna gain as the maximum eirp allowed is 10dBm/MHz. The limits are also corrected for instances where the highest measured value of the PSD exceeds the average PSD (calculated from the measured power divided by the measured 99% bandwidth) by more than 3dB by the amount that the measured value exceeds the average by more than 3dB.
Note 4:	99% Bandwidth measured in accordance with RSS GEN - RB > 1% of span and VB >=3xRB
Note 5:	For MIMO systems the total output power and total PSD are calculated from the sum of the powers of the individual chains (in linear terms). The antenna gain used to determine the EIRP and limits for PSD/Output power depends on the operating mode of the MIMO device. If the signals on the non-coherent between the transmit chains then the gain used to determine the limits is the highest gain of the individual chains and the EIRP is the sum of the products of gain and power on each chain. If the signals are coherent then the effective antenna gain is the sum (in linear terms) of the gains for each chain and the EIRP is the product of the effective gain and total power.

Client: Xirrus	Job Number: J71456
Model: XN16 and XN8	T-Log Number: T71644
Contact: Steve Smith	Account Manager: Susan Pezli
Standard: -	Class: N/A

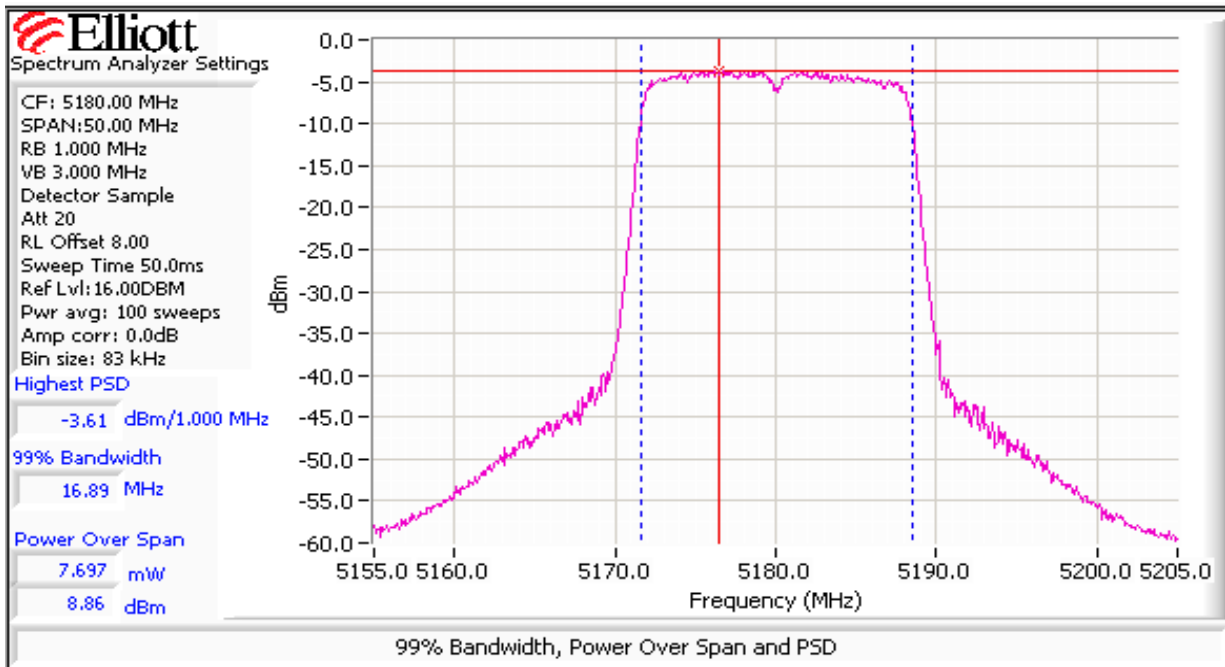
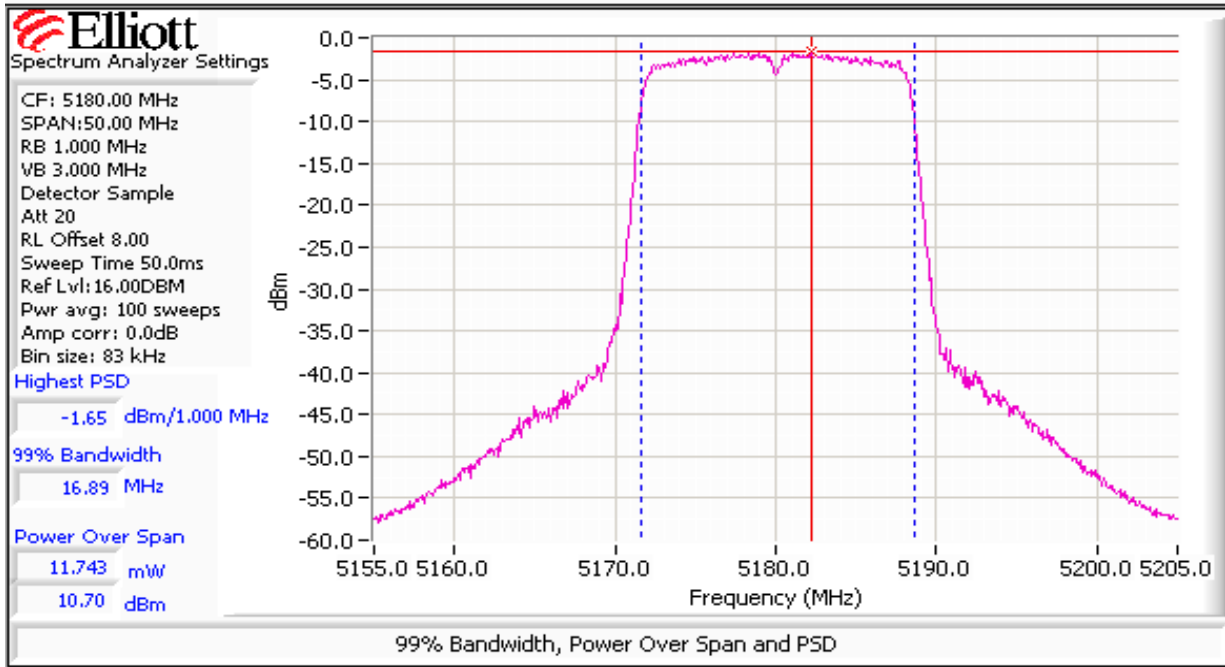

Client: Xirrus	Job Number: J71456
Model: XN16 and XN8	T-Log Number: T71644
Contact: Steve Smith	Account Manager: Susan Pezli
Standard: -	Class: N/A

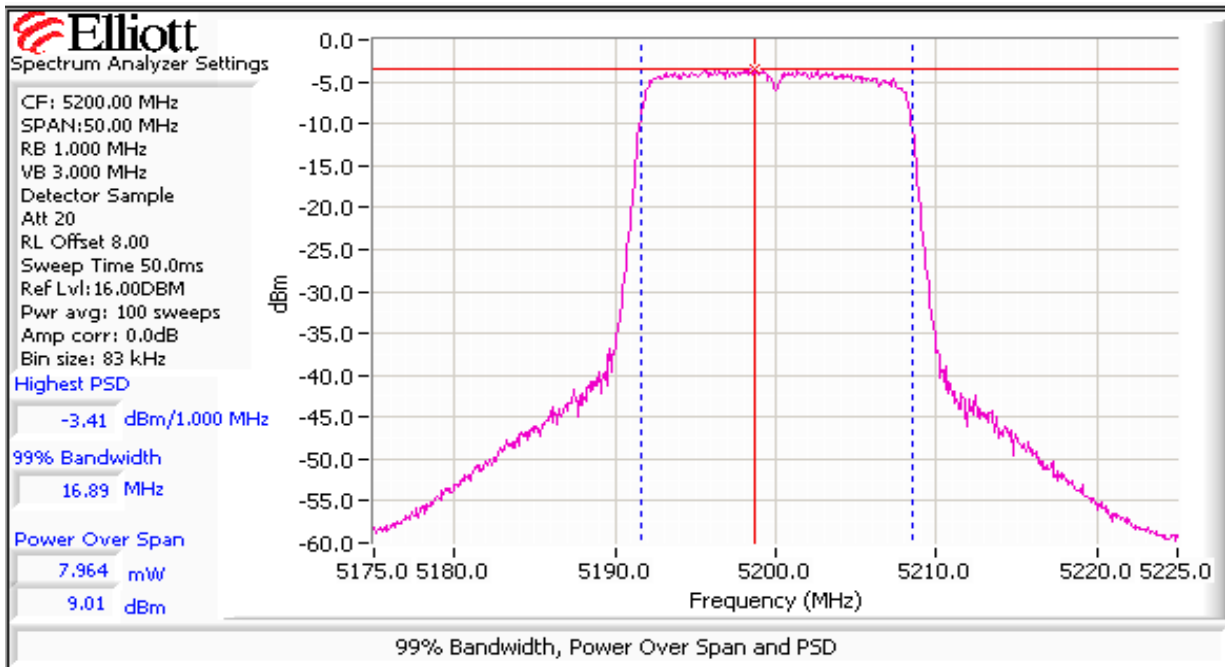
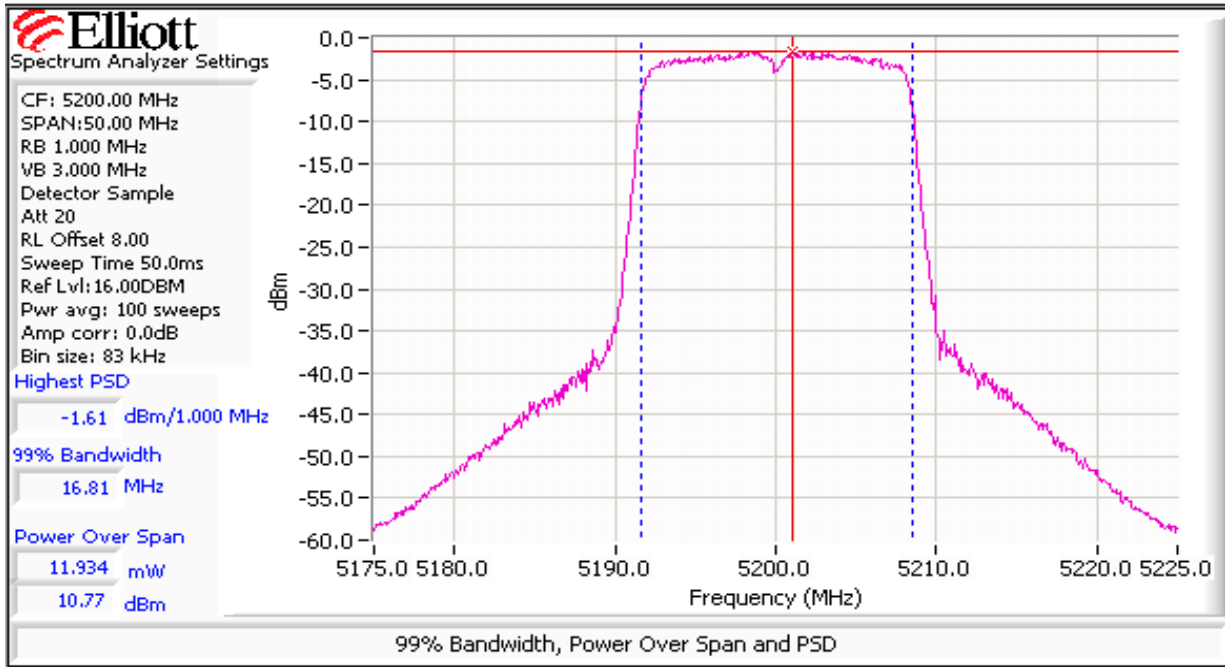

Client: Xirrus	Job Number: J71456
Model: XN16 and XN8	T-Log Number: T71644
	Account Manager: Susan Pezli
Contact: Steve Smith	
Standard: -	Class: N/A

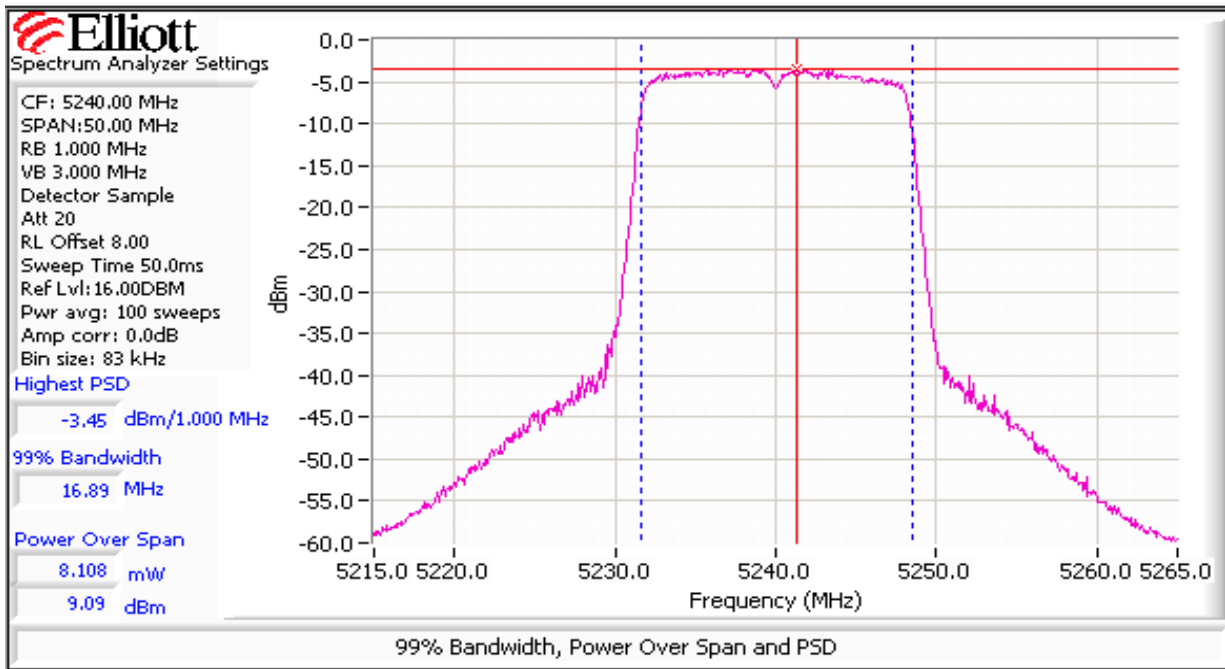
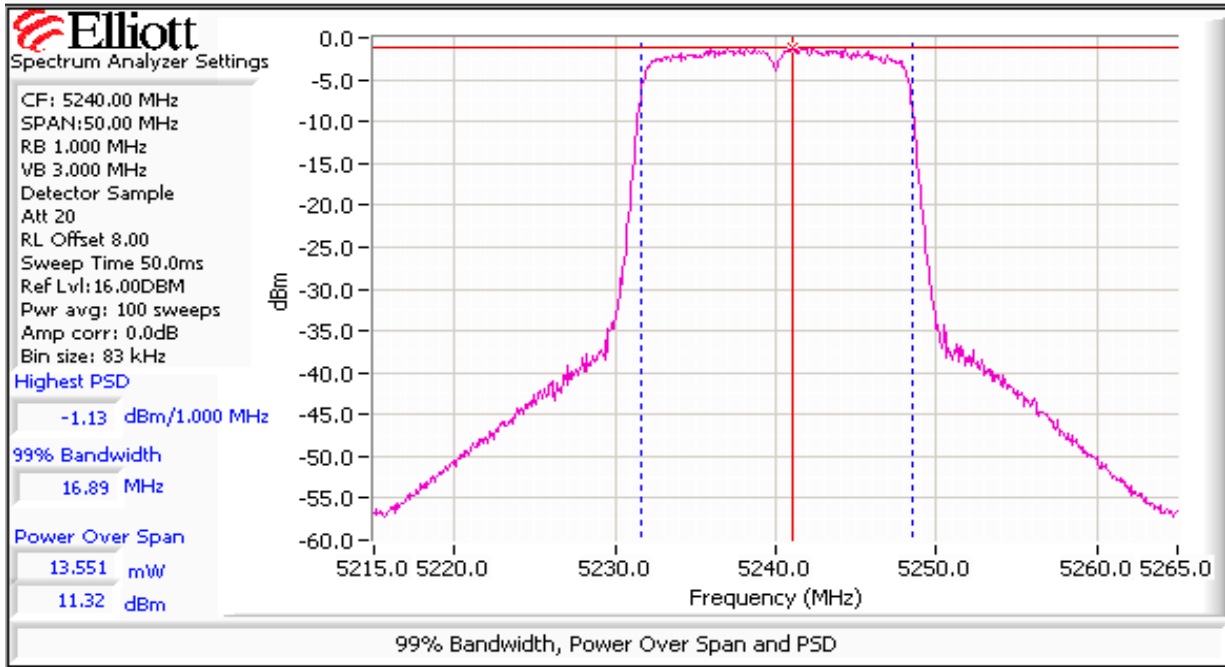

Client: Xirus	Job Number: J71456
Model: XN16 and XN8	T-Log Number: T71644
Contact: Steve Smith	Account Manager: Susan Pezli
Standard: -	Class: N/A

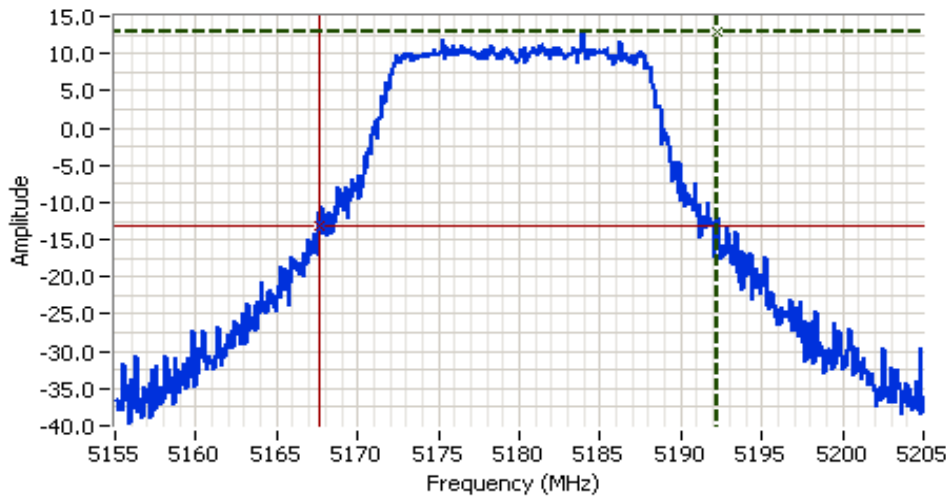

Analyzer Settings
 HP8564E,006,EMI,UK6
 CF: 5180.000 MHz
 SPAN:50.000 MHz
 RB 1.000 MHz
 VB 3.000 MHz
 Detector POS
 Att 20
 RL Offset 8.00
 Sweep Time 50.0ms
 Ref Lvl:16.00DBM

Comments
 26dB BW: 24.583 MHz

Cursor 1	5192.2500	12.83	
Cursor 2	5167.6667	-13.17	

Delta Freq. 24.583
 Delta Amplitude 26.00

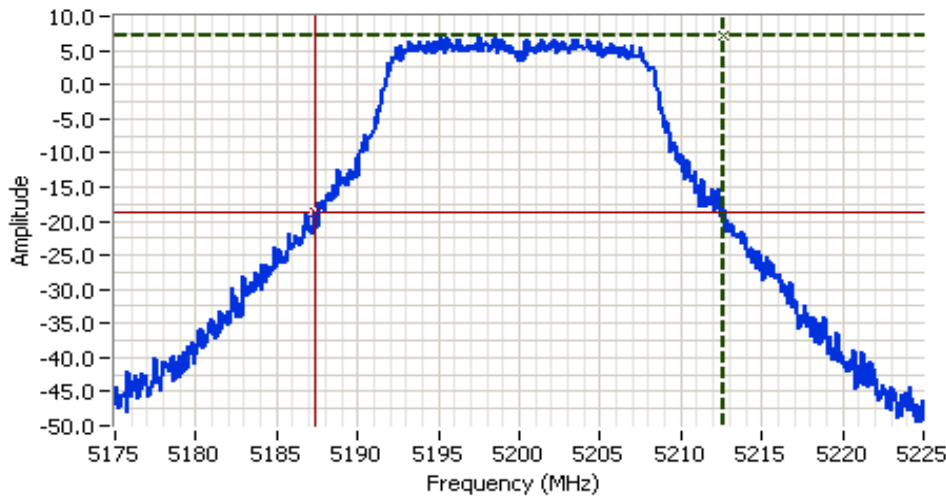

Analyzer Settings
 HP8564E,006,EMI,UK6
 CF: 5200.000 MHz
 SPAN:50.000 MHz
 RB 1.000 MHz
 VB 3.000 MHz
 Detector Sample
 Att 20
 RL Offset 8.00
 Sweep Time 50.0ms
 Ref Lvl:16.00DBM

Comments
 26dB BW: 25.333 MHz

Cursor 1	5212.6667	7.17	
Cursor 2	5187.3333	-18.83	

Delta Freq. 25.333
 Delta Amplitude 26.00



Client: Xirus	Job Number: J71456
Model: XN16 and XN8	T-Log Number: T71644
Contact: Steve Smith	Account Manager: Susan Pezli
Standard: -	Class: N/A

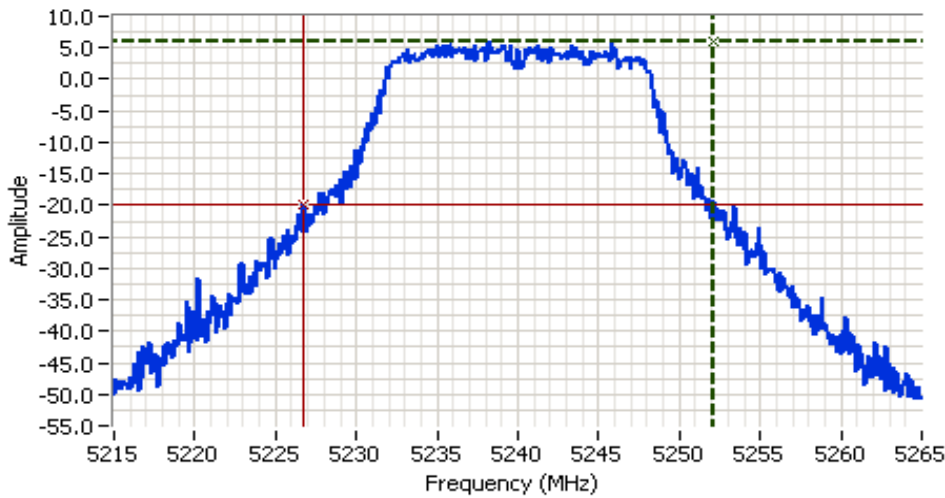

Analyzer Settings

HP8564E,006,EMI,UK6
 CF: 5240.000 MHz
 SPAN:50.000 MHz
 RB 1.000 MHz
 VB 3.000 MHz
 Detector POS
 Att 20
 RL Offset 8.00
 Sweep Time 50.0ms
 Ref Lvl:16.00DBM

Comments

26dB BW: 25.417 MHz

Cursor 1	5252.1667	6.00	
Cursor 2	5226.7500	-20.00	

Delta Freq. 25.417
 Delta Amplitude 26.00



Power settings for all four 802.11a channels being used in the band:

The device adjusts output power downwards if multiple radios operate in the same band to maintain compliance with the total power limit for the band. Measurements were made at the lowest required power setting (i.e. all non-overlapping channels in the band occupied) to verify the device has the dynamic range to do this.

Frequency (MHz)	Software Setting	26dB BW (MHz)	Measured Output Power ¹ dBm			Total		Only power was measured - aggregation of PSD is not applicable as the device cannot operate on overlapping channels		
			Chain 1	Chain 2	Chain 3	mW	dBm			
5180	6.5		5.5		3.4	5.7	7.6			
5200	6.0		5.3		3.2	5.5	7.4			
5220	6.0		5.7		3.4	5.9	7.7			
5240	6.0	25.4	6.1		3.3	6.2	8.0			
Total power in the band:						23.4	13.7	14.0	0.023	PASS

Note 1: Output power measured using a spectrum analyzer (see plots below for the high power measurements): RBW=1MHz, VB=3 MHz, sample detector, power averaging on (transmitted signal was continuous) and power integration over 50MHz.

Client: Xirrus	Job Number: J71456
Model: XN16 and XN8	T-Log Number: T71644
Contact: Steve Smith	Account Manager: Susan Pezli
Standard: -	Class: N/A

Run #2: Peak Excursion Measurement

Device meets the requirement for the peak excursion

Peak Excursion (dB)			Peak Excursion (dB)			Peak Excursion (dB)		
Freq (MHz)	Value	Limit	Freq (MHz)	Value	Limit	Freq (MHz)	Value	Limit
5180	12.2	13.0	5260		13.0	5500		13.0
5200	12.5	13.0	5300		13.0	5600		13.0
5240	11.9	13.0	5320		13.0	5700		13.0

Plots Showing Peak Excursion

Trace A: RBW = VBW = 3MHz, Peak hold
Trace B: RBW = 1 MHz, VBW = 3MHz, Integrated average power

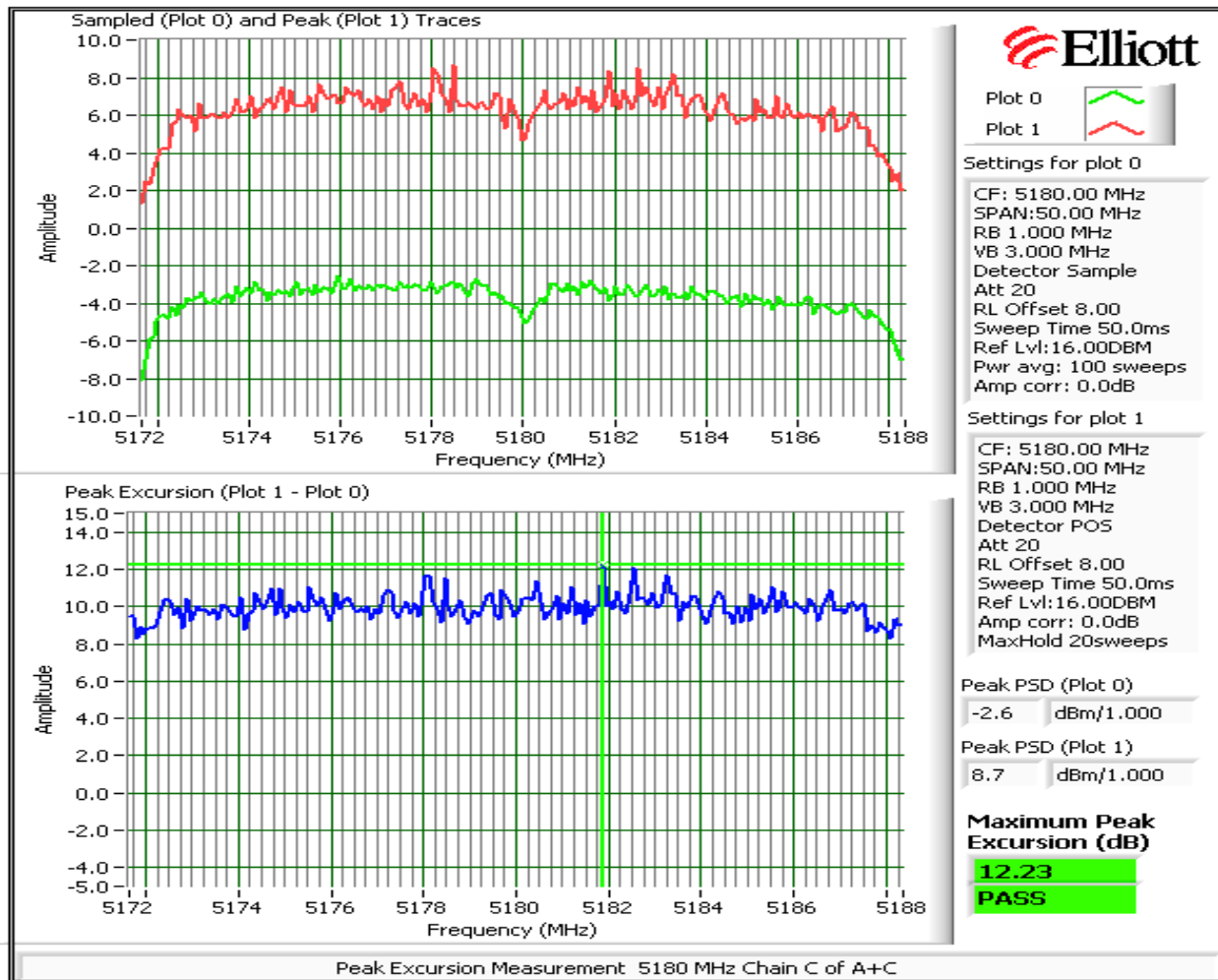

Client: Xirrus	Job Number: J71456
Model: XN16 and XN8	T-Log Number: T71644
Contact: Steve Smith	Account Manager: Susan Pezli
Standard: -	Class: N/A

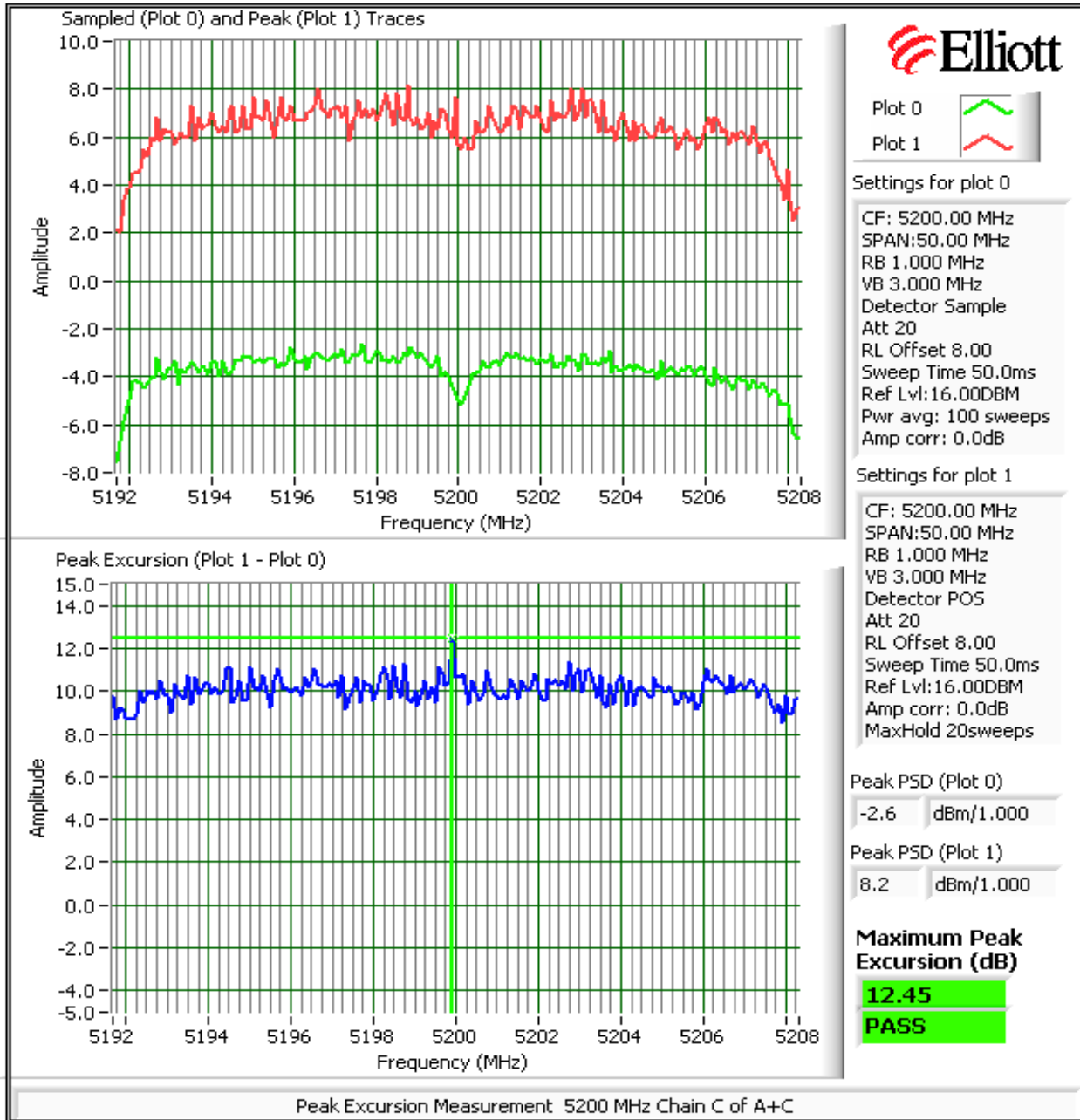

Client: Xirrus	Job Number: J71456
Model: XN16 and XN8	T-Log Number: T71644
	Account Manager: Susan Pezli
Contact: Steve Smith	
Standard: -	Class: N/A

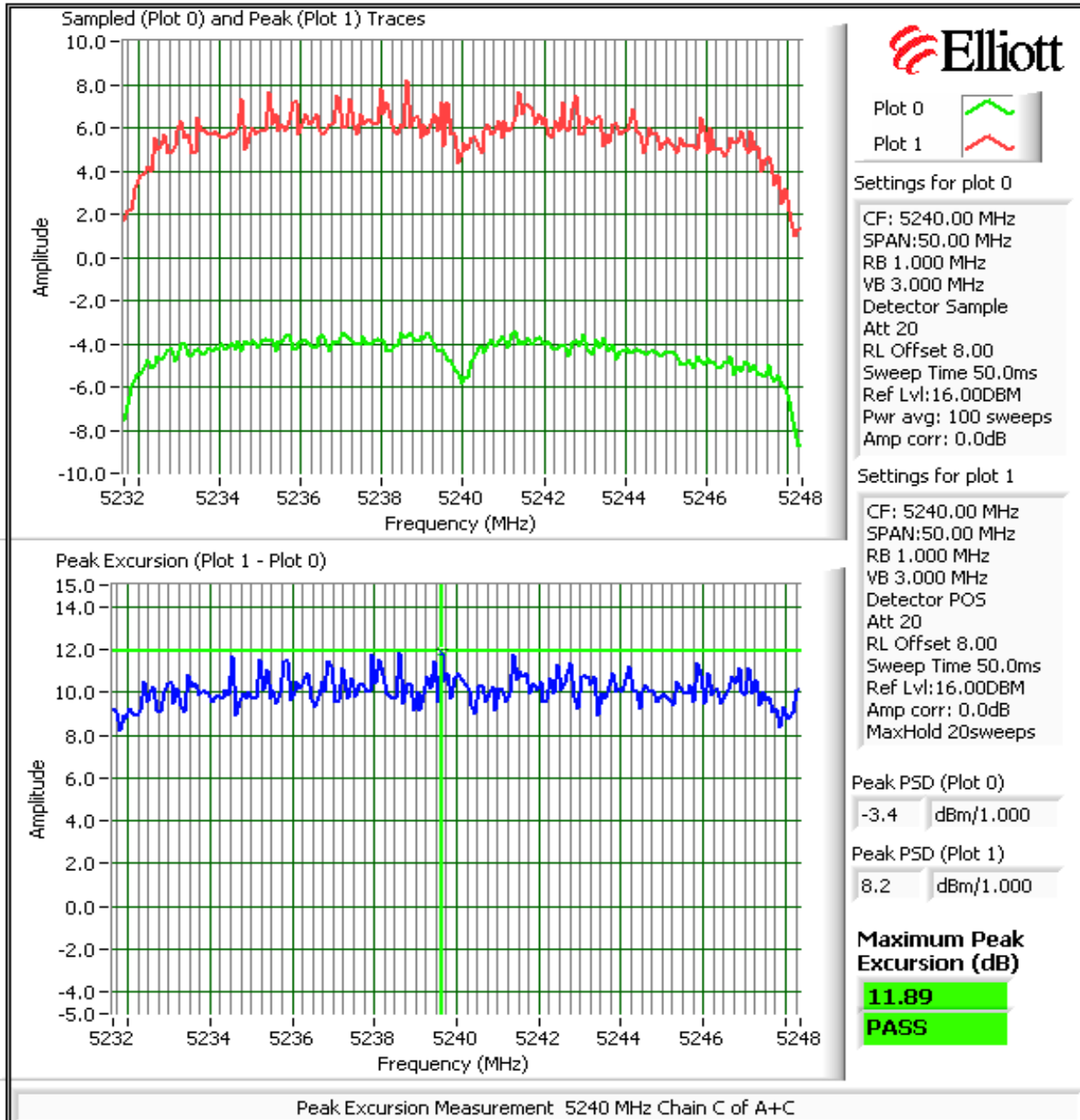

Client: Xirrus	Job Number: J71456
Model: XN16 and XN8	T-Log Number: T71644
	Account Manager: Susan Pezli
Contact: Steve Smith	
Standard: -	Class: N/A

RSS-210 (LELAN) and FCC 15.407(UNII)
Antenna Port Measurements
Power, PSD, Peak Excursion, Bandwidth and Spurious Emissions

Test Specific Details

Objective: The objective of this test session is to perform final qualification testing of the EUT with respect to the specification listed above.

Date of Test: 6/2/2008	Config. Used: 1
Test Engineer: Suhaila Khushzad	Config Change: None
Test Location: OATS # 1	EUT Voltage: POE

General Test Configuration

When measuring the conducted emissions from the EUT's antenna port, the antenna port of the EUT was connected to the spectrum analyzer or power meter via a suitable attenuator to prevent overloading the measurement system. All measurements are corrected to allow for the external attenuators and cables used.

Ambient Conditions: Temperature: 21 °C
 Rel. Humidity: 50 %

Summary of Results

Run #	Mode	Test Performed	Limit	Pass / Fail	Result / Margin
1	n20MHz	Power, 5150 - 5250MHz	15.407(a) (1), (2)	Pass	16.7 dBm (46.8mW)
1	n20MHz	PSD, 5150 - 5250MHz	15.407(a) (1), (2)	Pass	4.0 dBm/MHz
1	n20MHz	99% Bandwidth	RSS 210	-	18.4 MHz
1	n40MHz	Power, 5150 - 5250MHz	15.407(a) (1), (2)	Pass	11.1 dBm (12.8mW)
1	n40MHz	PSD, 5150 - 5250MHz	15.407(a) (1), (2)	Pass	0.8 dBm/MHz
1	n40MHz	99% Bandwidth	RSS 210	-	36.8 MHz
2	n20 & n40	Peak Excursion Envelope	15.407(a) (6)	Pass	12.5 dB
3	n20 & n40	Antenna Conducted Spurious	15.407(b)	Pass	< -27dBm/MHz eirp

Modifications Made During Testing

No modifications were made to the EUT during testing

Deviations From The Standard

No deviations were made from the requirements of the standard.

Client: Xirrus	Job Number: J71456
Model: XN16 and XN8	T-Log Number: T71644
	Account Manager: Susan Pezli
Contact: Steve Smith	
Standard: -	Class: N/A

Run #1: Bandwidth, Output Power and Power spectral Density

Antenna gain used is for the internal antenna. The external antenna gain is lower (2.5dBi) and not used for MIMO modes.

	Chain 1	Chain 2	Chain 3	Coherent	Effective ⁵
Antenna Gain (dBi):	6		6	No	6.0

Power settings for a single radio operating in the band

Frequency (MHz)	Software Setting	26dB BW (MHz)	Measured Output Power ¹ dBm			Total		Limit (dBm)	Max Power (W)	Pass or Fail
			Chain 1	Chain 2	Chain 3	mW	dBm			
5180	15.0	27.2	14.4		12.9	46.8	16.7	17.0	0.047	PASS
5200	14.5	26.8	13.8		12.9	43.0	16.3	17.0		PASS
5240	15.0	27.3	13.7		13.7	46.8	16.7	17.0		PASS
5190	9.0	49.8	8.8		7.2	12.8	11.1	17.0	0.047	PASS
5230	15.0	48.3	14.0		13.5	47.0	16.7	17.0		PASS

Frequency (MHz)	99% ⁴ BW	Total Power	PSD ² dBm/MHz			Total PSD		Limit		Pass or Fail
			Chain 1	Chain 2	Chain 3	mW/MHz	dBm/MHz	FCC	RSS 210 ³	
5180	18.4	16.7	1.6		-0.1	2.4	3.9	4.0	4.0	PASS
5200	18.4	16.3	1.1		0.1	2.3	3.6	4.0	4.0	PASS
5240	18.4	16.7	1.0		0.9	2.5	4.0	4.0	4.0	PASS
5190	36.8	11.1	-7.2		-8.6	0.3	-4.8	4.0	4.0	PASS
5230	36.8	16.7	-2.1		-2.3	1.2	0.8	4.0	4.0	PASS

Power settings for all four n20 channels and both n40 channels being used in the band:

The device adjusts output power downwards if multiple radios operate in the same band to maintain compliance with the total power limit for the band. Measurements were made at the lowest required power setting (i.e. all non-overlapping channels in the band occupied) to verify the device has the dynamic range to do this.

The lowest power level required per radio is 14dBm for the n40Mhz (two 40 Mhz or one 40Mhz channel and one 20Mhz channel available, with both radios at 14dBm the total power in the band is 17dBm).

n20 MHz

Frequency (MHz)	Software Setting	26dB BW (MHz)	Measured Output Power ¹ dBm			Total		Only power was measured - aggregation of PSD is not applicable as the device cannot operate on overlapping channels		
			Chain 1	Chain 2	Chain 3	mW	dBm			
5180	8.5		8.5		6.8	11.9	10.8	Limit (dBm)	Max Power (W)	Pass or Fail
5200	8.5		8.5		7.4	12.5	11.0			
5220	8.5		8.4		7.1	12.1	10.8			
5240	8.5	27.3	8.3		7.9	12.9	11.1			
Total power in the band:						49.4	16.9	17.0	0.049	PASS

Client: Xirrus	Job Number: J71456
Model: XN16 and XN8	T-Log Number: T71644
	Account Manager: Susan Pezli
Contact: Steve Smith	
Standard: -	Class: N/A

n40 MHz

The lowest power level required per radio is 14dBm for the n40MHz (two 40 MHz or one 40MHz channel and one 20MHz channel available, with both radios at 14dBm the total power in the band is 17dBm).

Frequency (MHz)	Software Setting	26dB BW (MHz)	Measured Output Power ¹ dBm			Total		Limit (dBm)	Max Power (W)	Pass or Fail
			Chain 1	Chain 2	Chain 3	mW	dBm			
5190	9.0		8.8		7.2	12.8	11.1	17.0	0.036	PASS
5230	11.0	48.3	10.8		10.5	23.2	13.7			
Total power in the band:						36.0	15.6	17.0	0.036	PASS

Note 1: Output power measured using a spectrum analyzer (see plots below for the high power measurements): RBW=1MHz, VB=3 MHz, sample detector, power averaging on (transmitted signal was continuous) and power integration over 50MHz (20MHz mode) and 100MHz (40MHz mode)

Note 2: Measured using the same analyzer settings used for output power.

Note 3: For RSS-210 the limit for the 5150 - 5250 MHz band accounts for the antenna gain as the maximum eirp allowed is 10dBm/MHz. The limits are also corrected for instances where the highest measured value of the PSD exceeds the average PSD (calculated from the measured power divided by the measured 99% bandwidth) by more than 3dB by the amount that the measured value exceeds the average by more than 3dB.

Note 4: 99% Bandwidth measured in accordance with RSS GEN - RB > 1% of span and VB >=3xRB

Note 5: For MIMO systems the total output power and total PSD are calculated from the sum of the powers of the individual chains (in linear terms). The antenna gain used to determine the EIRP and limits for PSD/Output power depends on the operating mode of the MIMO device. If the signals are non-coherent between the transmit chains then the gain used to determine the limits is the highest gain of the individual chains and the EIRP is the sum of the products of gain and power on each chain. If the signals are coherent then the effective antenna gain is the sum (in linear terms) of the gains for each chain and the EIRP is the product of the effective gain and total power.

Client: Xirrus	Job Number: J71456
Model: XN16 and XN8	T-Log Number: T71644
Contact: Steve Smith	Account Manager: Susan Pezli
Standard: -	Class: N/A

Plots showing power/PSD measurements and 26dB bandwidth measurements at the high power setting

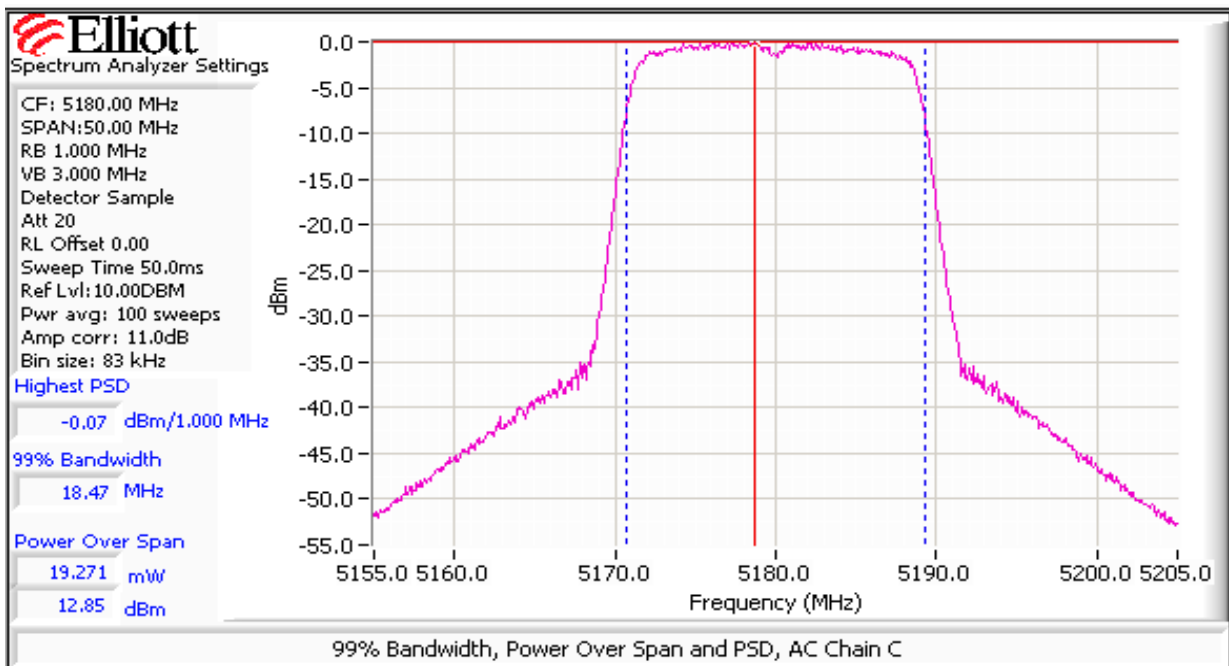
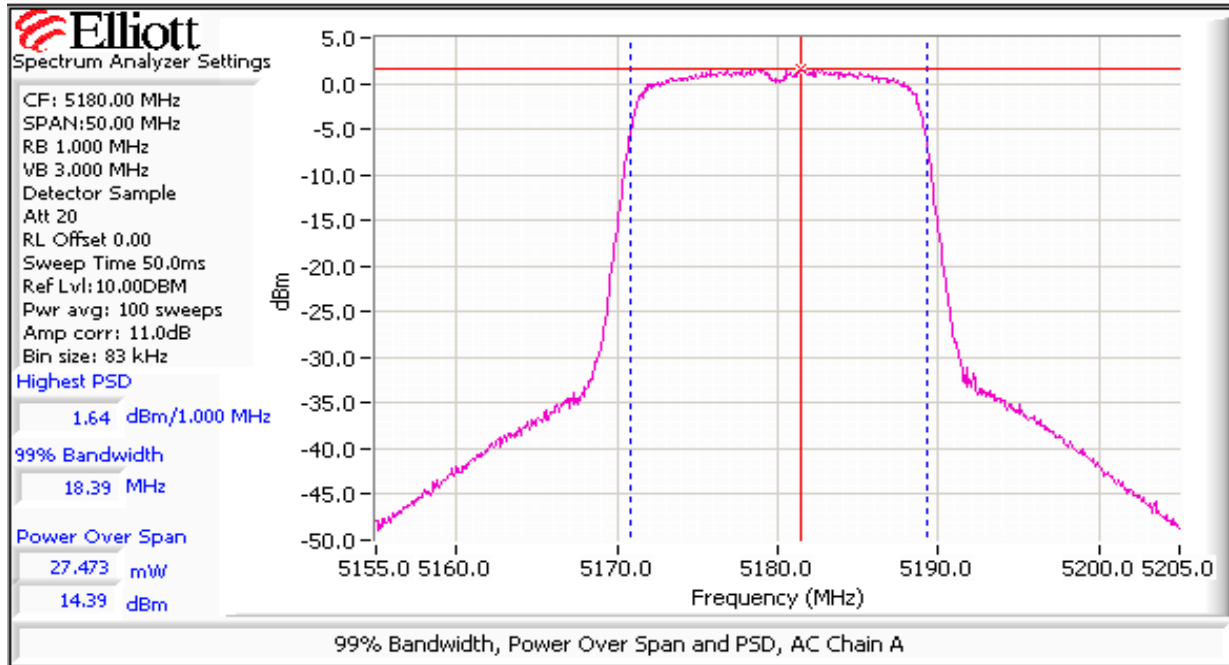

Client: Xirrus	Job Number: J71456
Model: XN16 and XN8	T-Log Number: T71644
Contact: Steve Smith	Account Manager: Susan Pezli
Standard: -	Class: N/A

Plots showing power/PSD measurements and 26dB bandwidth measurements at the high power setting

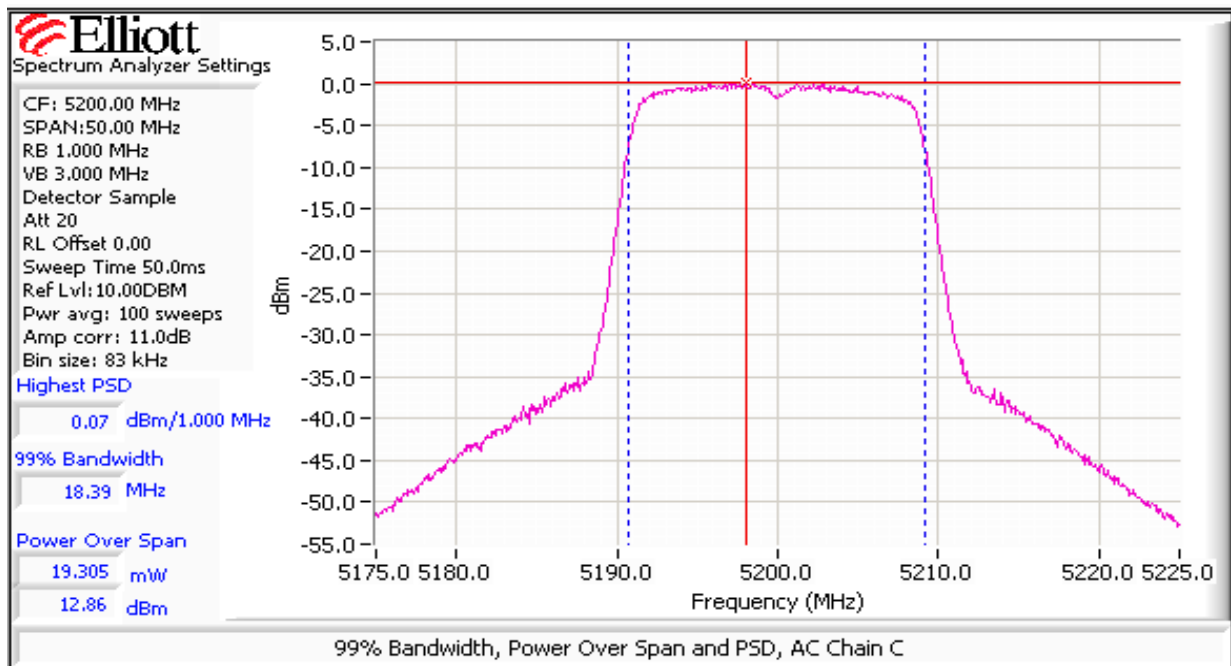
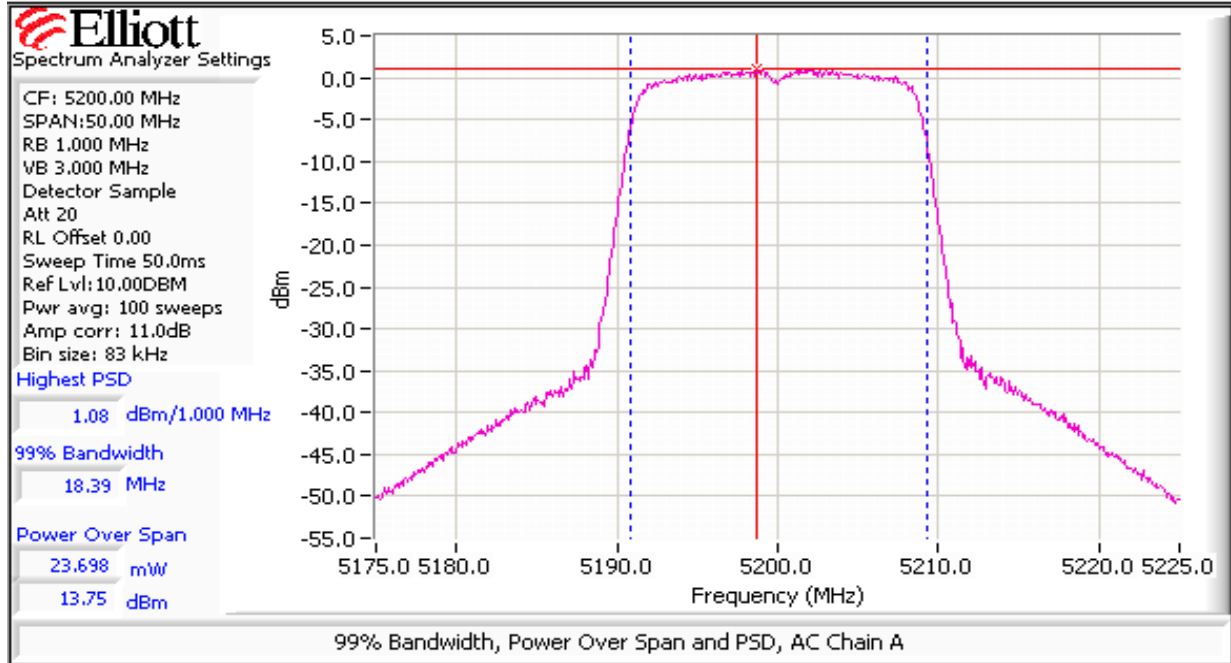

Client: Xirrus	Job Number: J71456
Model: XN16 and XN8	T-Log Number: T71644
Contact: Steve Smith	Account Manager: Susan Pezli
Standard: -	Class: N/A

Plots showing power/PSD measurements and 26dB bandwidth measurements at the high power setting

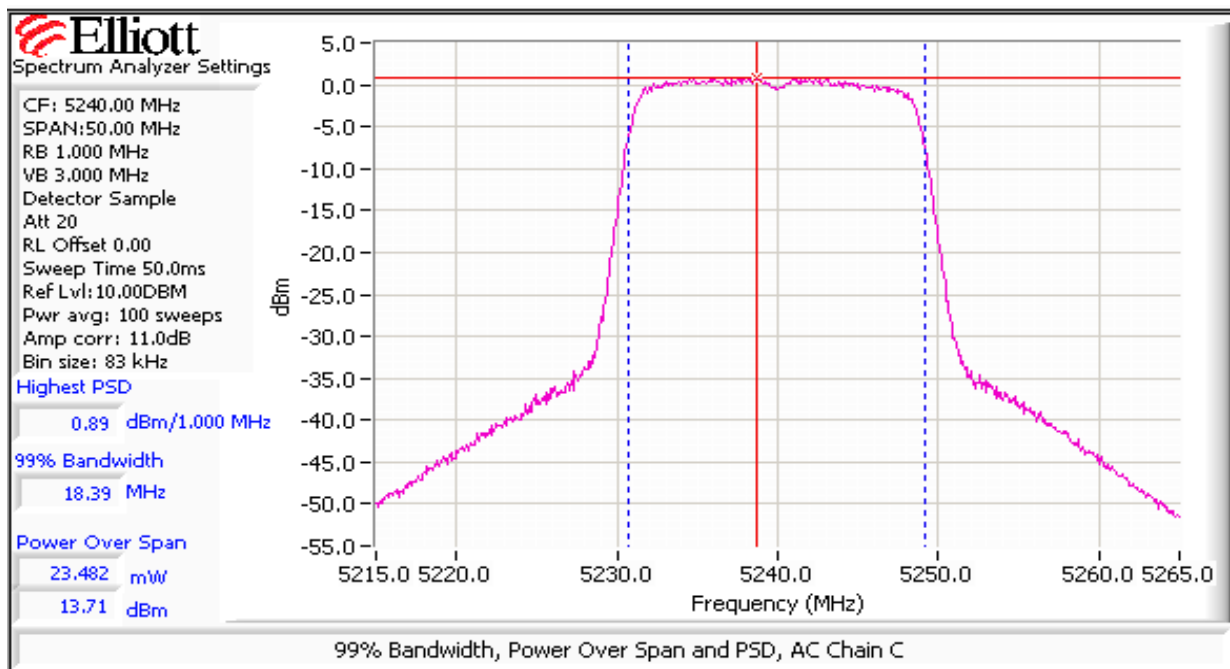
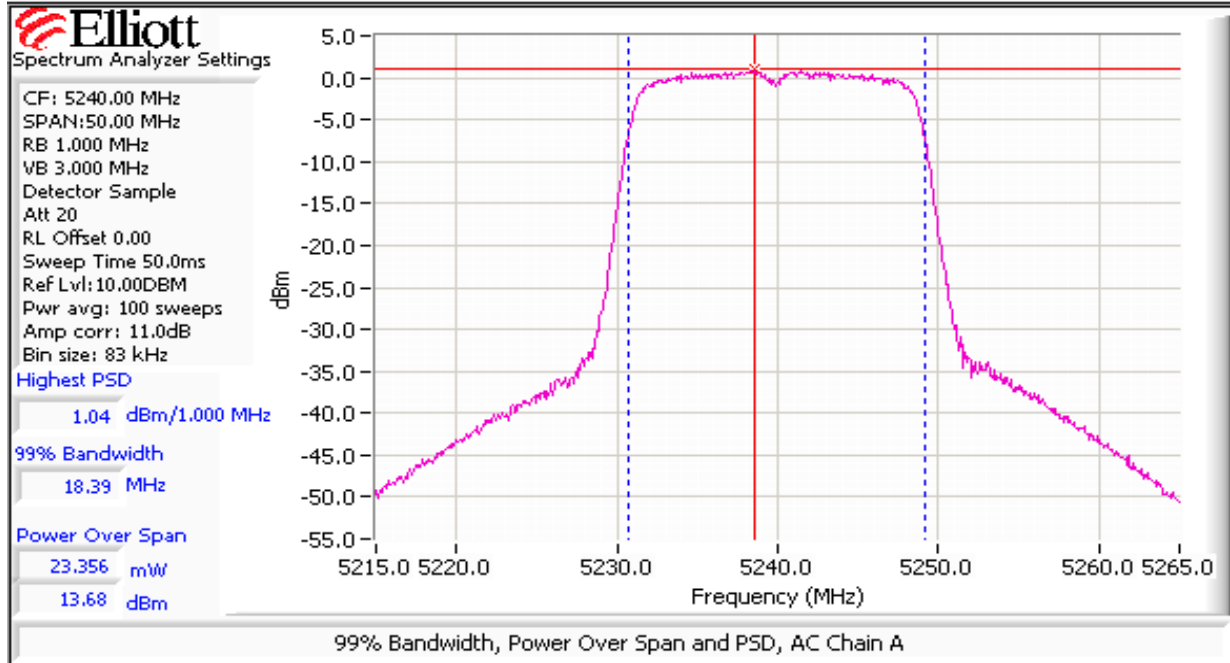

Client: Xirrus	Job Number: J71456
Model: XN16 and XN8	T-Log Number: T71644
Contact: Steve Smith	Account Manager: Susan Pezli
Standard: -	Class: N/A

Plots showing power/PSD measurements and 26dB bandwidth measurements at the high power setting

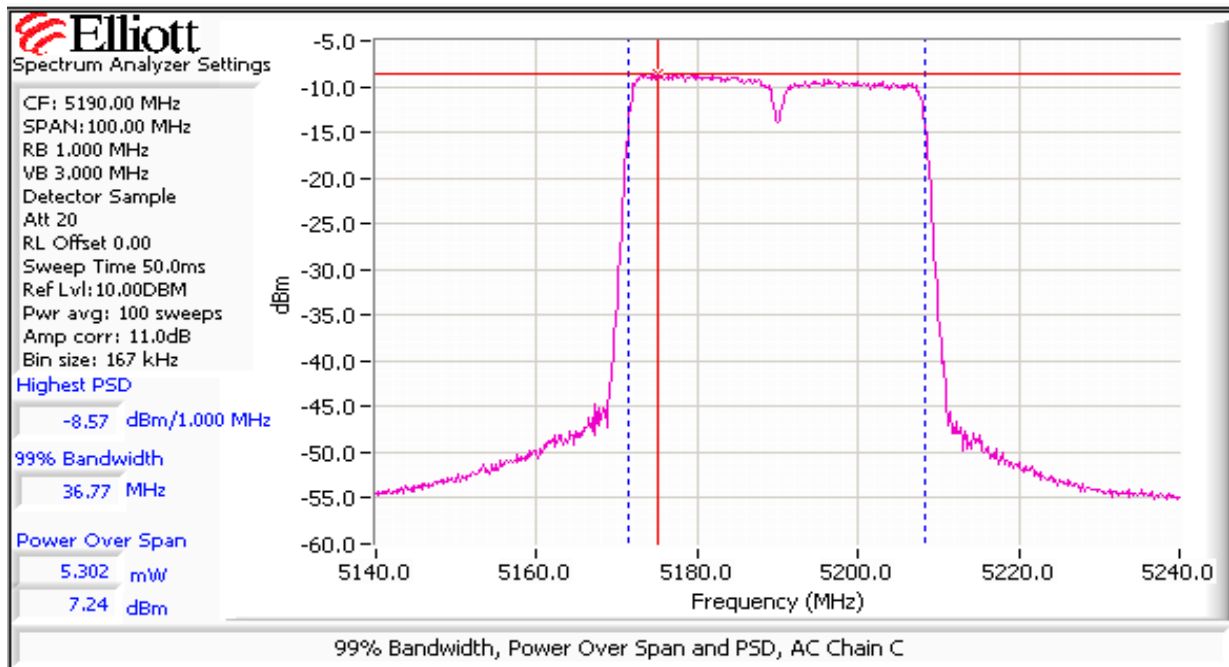
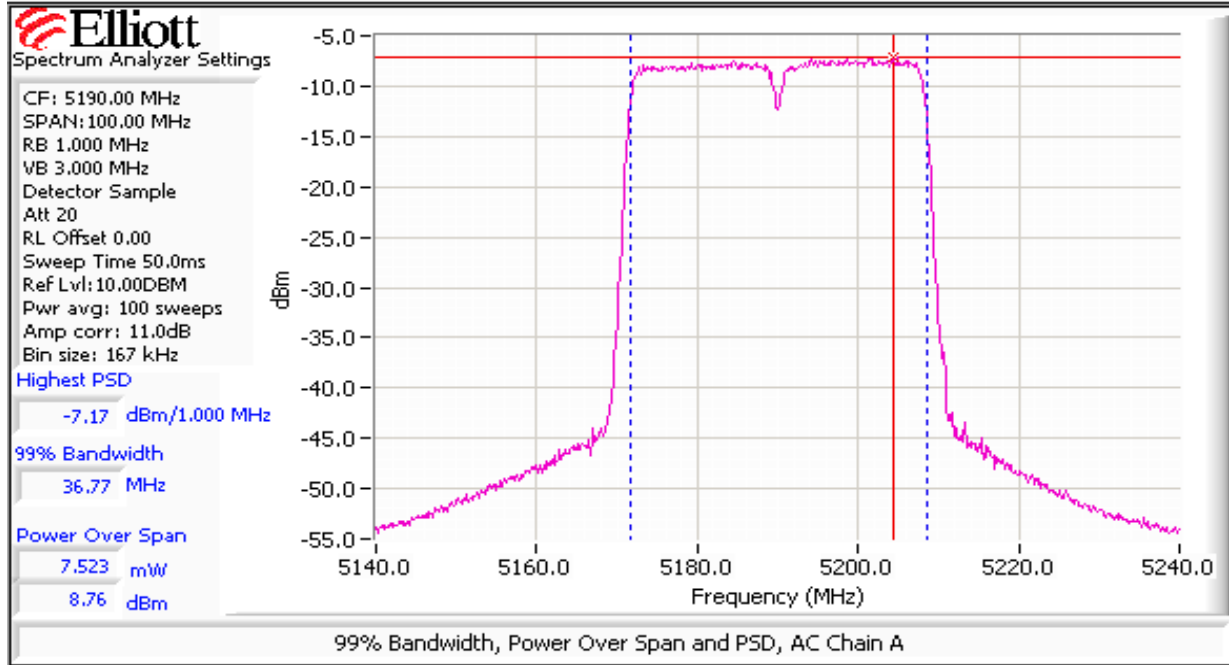

Client: Xirus	Job Number: J71456
Model: XN16 and XN8	T-Log Number: T71644
Contact: Steve Smith	Account Manager: Susan Pezli
Standard: -	Class: N/A

Plots showing power/PSD measurements and 26dB bandwidth measurements at the high power setting

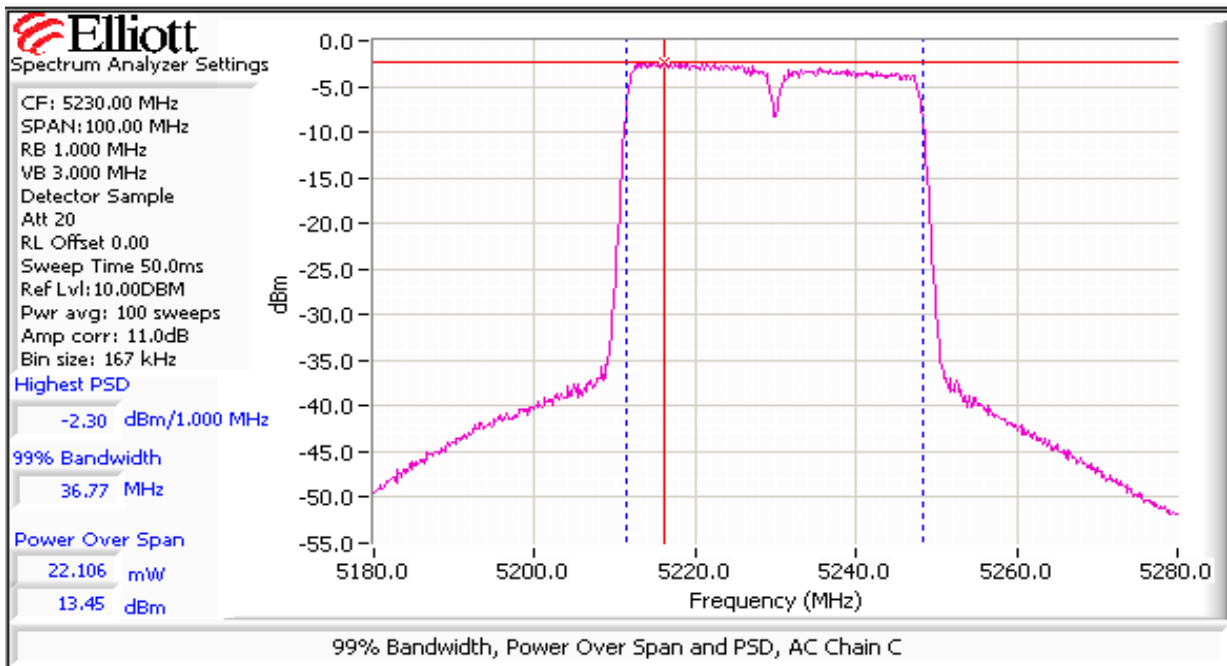
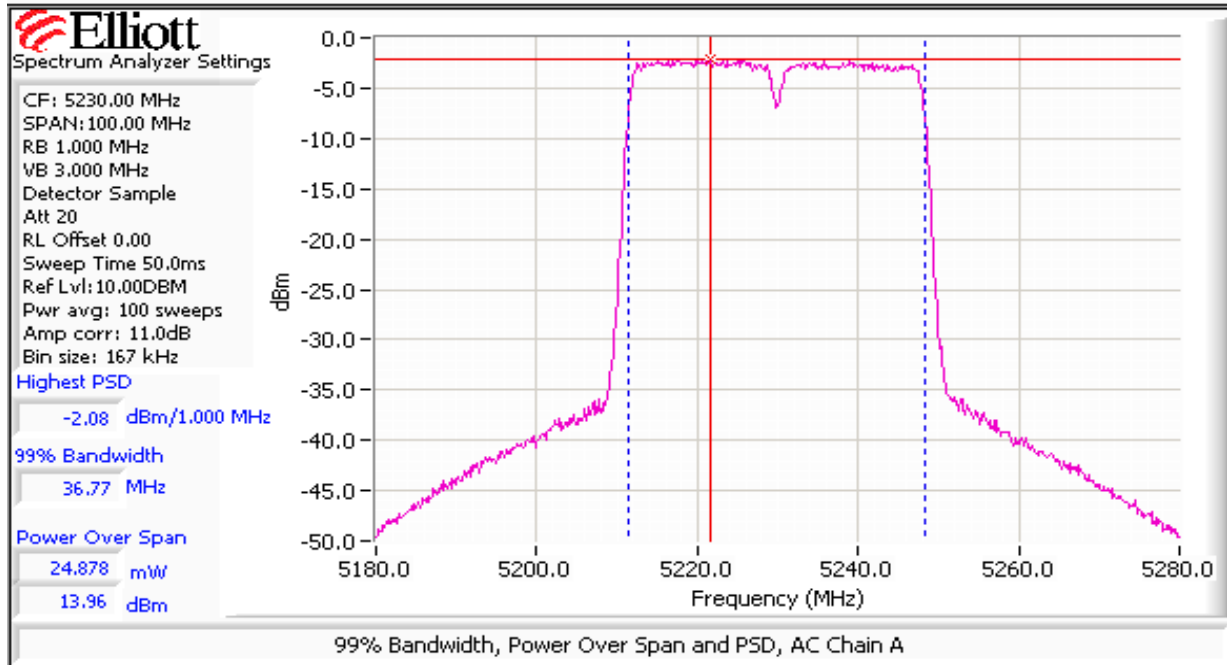

Client: Xirrus	Job Number: J71456
Model: XN16 and XN8	T-Log Number: T71644
Contact: Steve Smith	Account Manager: Susan Pezl
Standard: -	Class: N/A

Plots showing power/PSD measurements and 26dB bandwidth measurements at the high power setting

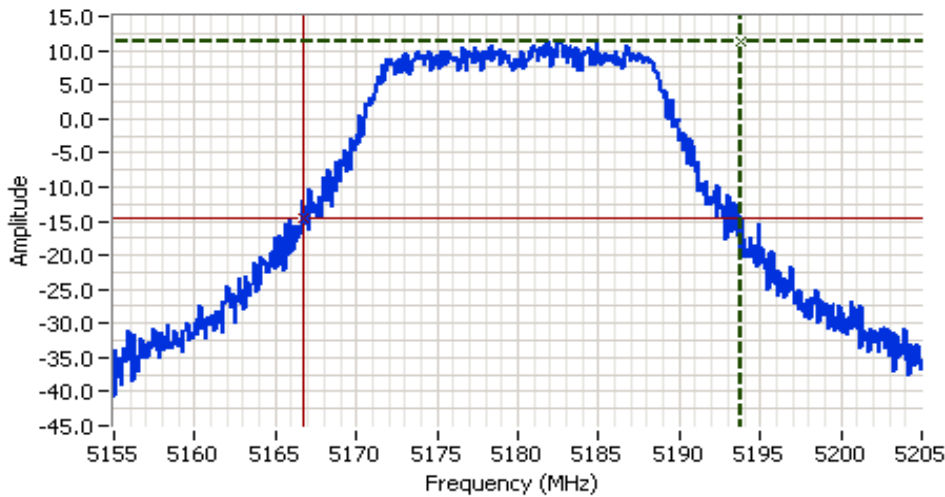

Analyzer Settings
 HP8564E
 CF: 5180.000 MHz
 SPAN:50.000 MHz
 RB 1.000 MHz
 VB 3.000 MHz
 Detector POS
 Att 20
 RL Offset 11.00
 Sweep Time 50.0ms
 Ref Lvl:21.00DBM

Comments
 26dB BW: 27.167 MHz
 n20, Chain AC

Cursor 1	5193.8333	11.33	
Cursor 2	5166.6667	-14.67	

Delta Freq. 27.167
 Delta Amplitude 26.00

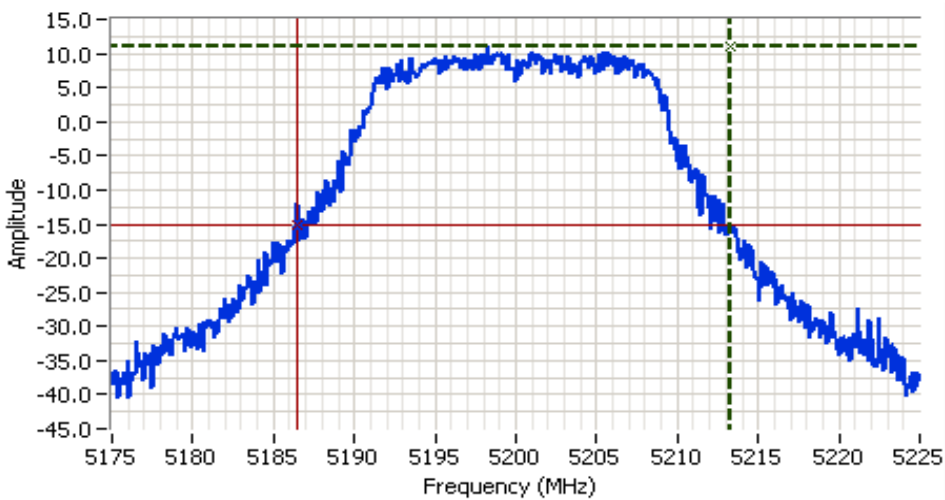

Analyzer Settings
 HP8564E
 CF: 5200.000 MHz
 SPAN:50.000 MHz
 RB 1.000 MHz
 VB 3.000 MHz
 Detector POS
 Att 20
 RL Offset 11.00
 Sweep Time 50.0ms
 Ref Lvl:21.00DBM

Comments
 26dB BW: 26.750 MHz
 n20, Chain AC

Cursor 1	5213.2500	11.00	
Cursor 2	5186.5000	-15.00	

Delta Freq. 26.750
 Delta Amplitude 26.00



Client: Xirrus	Job Number: J71456
Model: XN16 and XN8	T-Log Number: T71644
Contact: Steve Smith	Account Manager: Susan Pezli
Standard: -	Class: N/A

Plots showing power/PSD measurements and 26dB bandwidth measurements at the high power setting

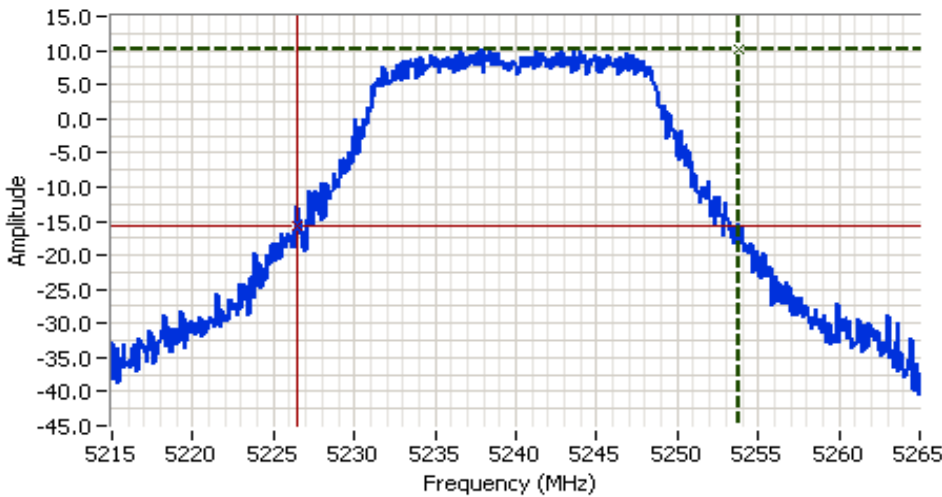

Analyzer Settings
 HP8564E
 CF: 5240.000 MHz
 SPAN:50.000 MHz
 RB 1.000 MHz
 VB 3.000 MHz
 Detector POS
 Att 20
 RL Offset 11.00
 Sweep Time 50.0ms
 Ref Lvl:21.00DBM

Comments
 26dB BW: 27.250 MHz
 n20, Chain AC

Cursor 1	5253.7500	10.17	
Cursor 2	5226.5000	-15.83	

Delta Freq. 27.250
 Delta Amplitude 26.00

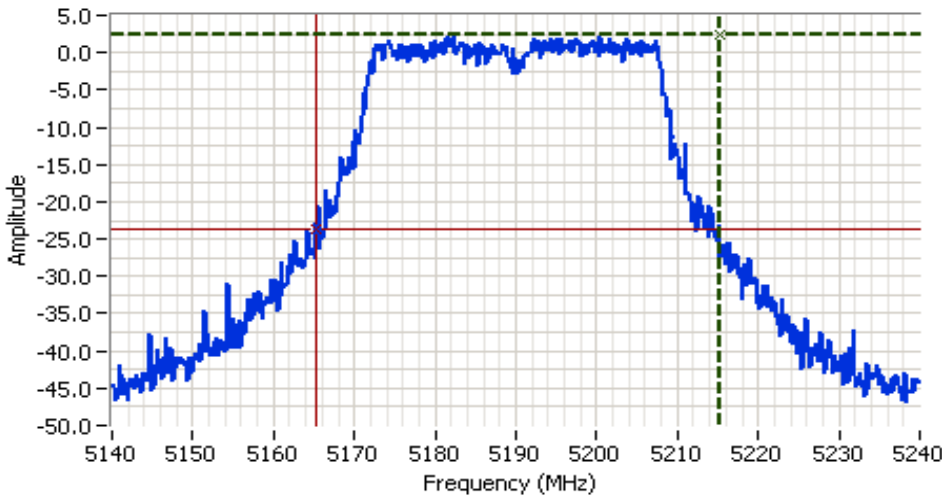

Analyzer Settings
 HP8564E
 CF: 5190.000 MHz
 SPAN:100.000 MHz
 RB 1.000 MHz
 VB 3.000 MHz
 Detector POS
 Att 20
 RL Offset 11.00
 Sweep Time 50.0ms
 Ref Lvl:21.00DBM

Comments
 26dB BW: 49.833 MHz
 n40 MHz, Chain AC

Cursor 1	5215.1667	2.33	
Cursor 2	5165.3333	-23.67	

Delta Freq. 49.833
 Delta Amplitude 26.00



Client: Xirrus	Job Number: J71456
Model: XN16 and XN8	T-Log Number: T71644
	Account Manager: Susan Pezli
Contact: Steve Smith	
Standard: -	Class: N/A

Plots showing power/PSD measurements and 26dB bandwidth measurements at the high power setting

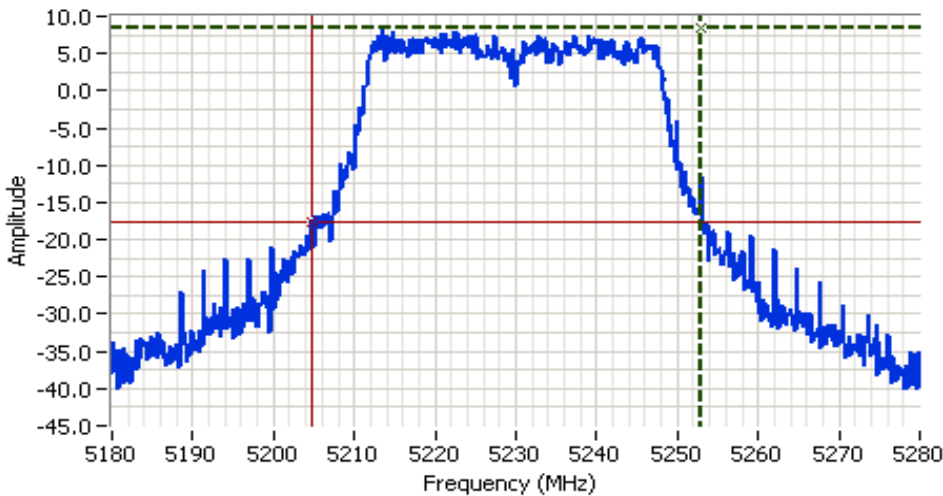

Analyzer Settings

HP8564E
 CF: 5230.000 MHz
 SPAN: 100.000 MHz
 RB 1.000 MHz
 VB 3.000 MHz
 Detector PO5
 Att 20
 RL Offset 11.00
 Sweep Time 50.0ms
 Ref Lvl: 21.00DBM

Comments

26dB BW: 48.333 MHz
 n20, Chain AC

Cursor 1	5253.0000	8.50		Delta Freq.	48.333
Cursor 2	5204.6667	-17.50		Delta Amplitude	26.00



Client: Xirrus	Job Number: J71456
Model: XN16 and XN8	T-Log Number: T71644
	Account Manager: Susan Pelzi
Contact: Steve Smith	
Standard: -	Class: N/A

Run #2: Peak Excursion Measurement
Device meets the requirement for the peak excursion

Freq (MHz)	Mode/ Chain	Peak Excursion(dB)	
		Value	Limit
5180	n20 A	11.9	13.0
5180	n20 C	11.7	13.0
5240	n20 A	11.8	13.0
5240	n20 C	11.0	13.0
5260	n20 A	11.2	13.0
5260	n20 C	11.8	13.0

Freq (MHz)	Mode/ Chain	Peak Excursion(dB)	
		Value	Limit
5190	n40 A	12.5	13.0
5190	n40 C	12.5	13.0
5230	n40 A	12.2	13.0
5230	n40 C	12.5	13.0

Plots Showing Peak Excursion

Trace A: RBW = VBW = 3MHz, Peak hold

Trace B: RBW = 1 MHz, VBW = 3MHz, Integrated average power

Client: Xirrus	Job Number: J71456
Model: XN16 and XN8	T-Log Number: T71644
Contact: Steve Smith	Account Manager: Susan Pezli
Standard: -	Class: N/A

Run #2: Peak Excursion Measurement

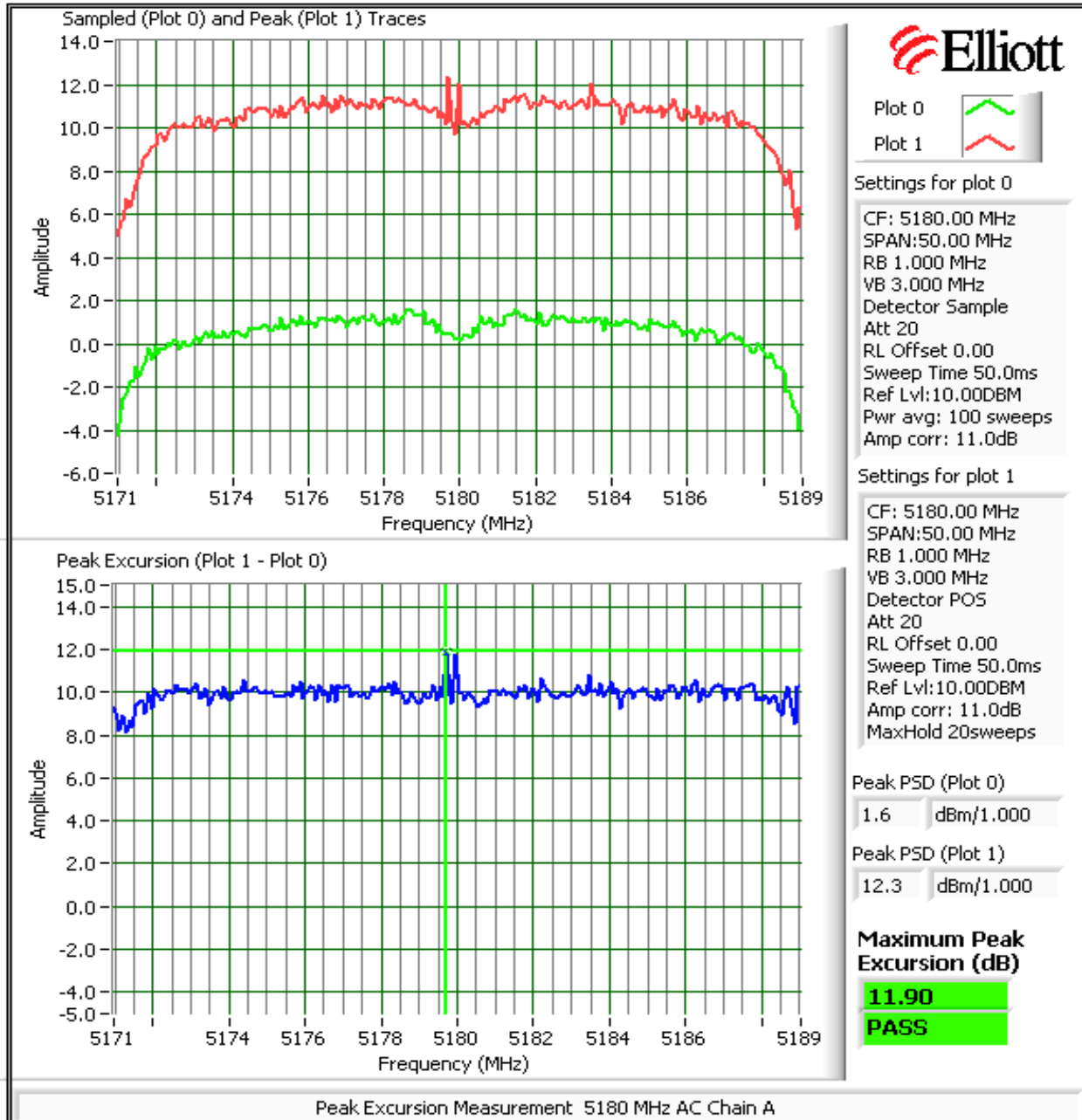

Client: Xirrus	Job Number: J71456
Model: XN16 and XN8	T-Log Number: T71644
Contact: Steve Smith	Account Manager: Susan Pezli
Standard: -	Class: N/A

Run #2: Peak Excursion Measurement

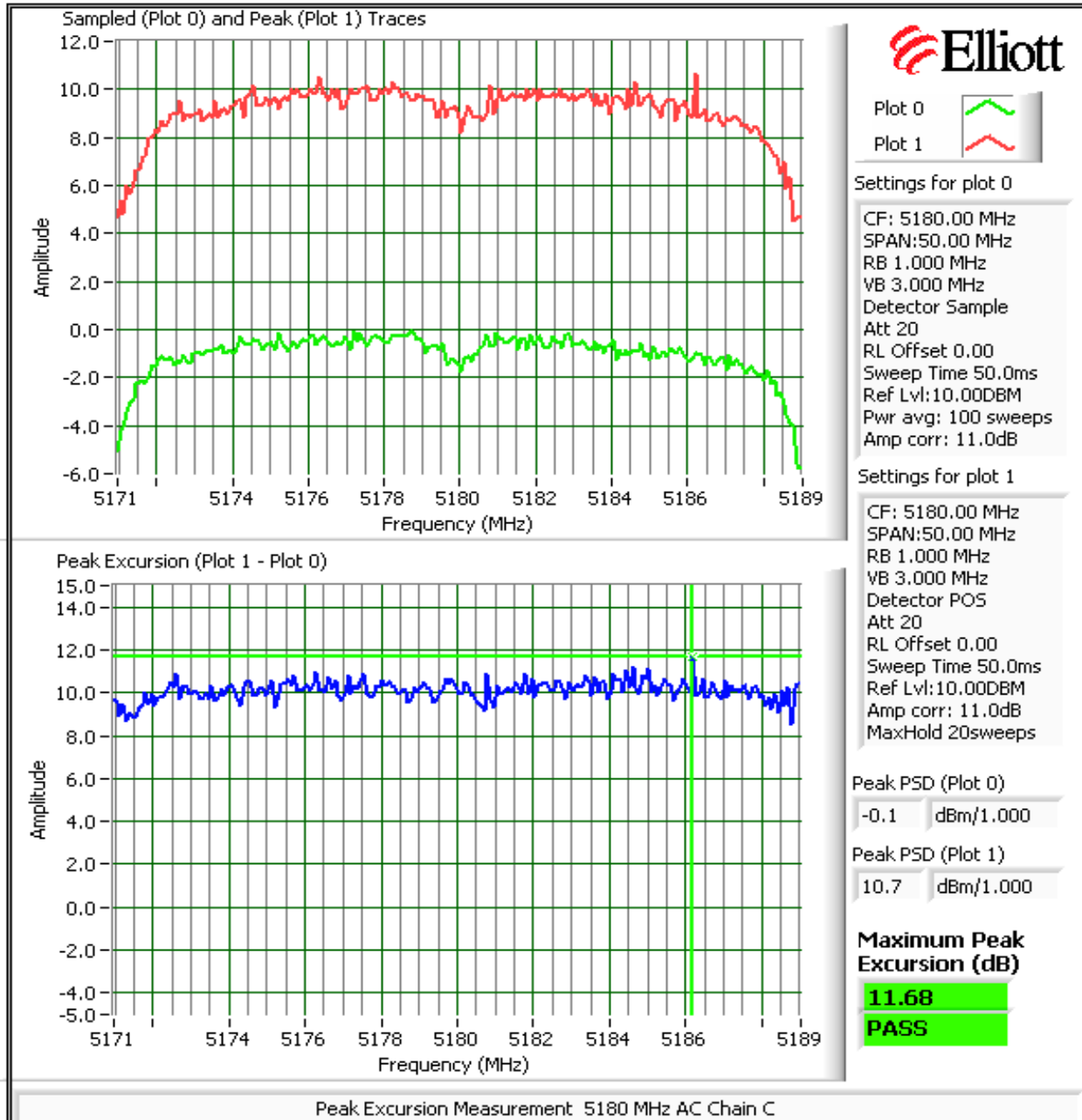

Client: Xirrus	Job Number: J71456
Model: XN16 and XN8	T-Log Number: T71644
Contact: Steve Smith	Account Manager: Susan Pezli
Standard: -	Class: N/A

Run #2: Peak Excursion Measurement

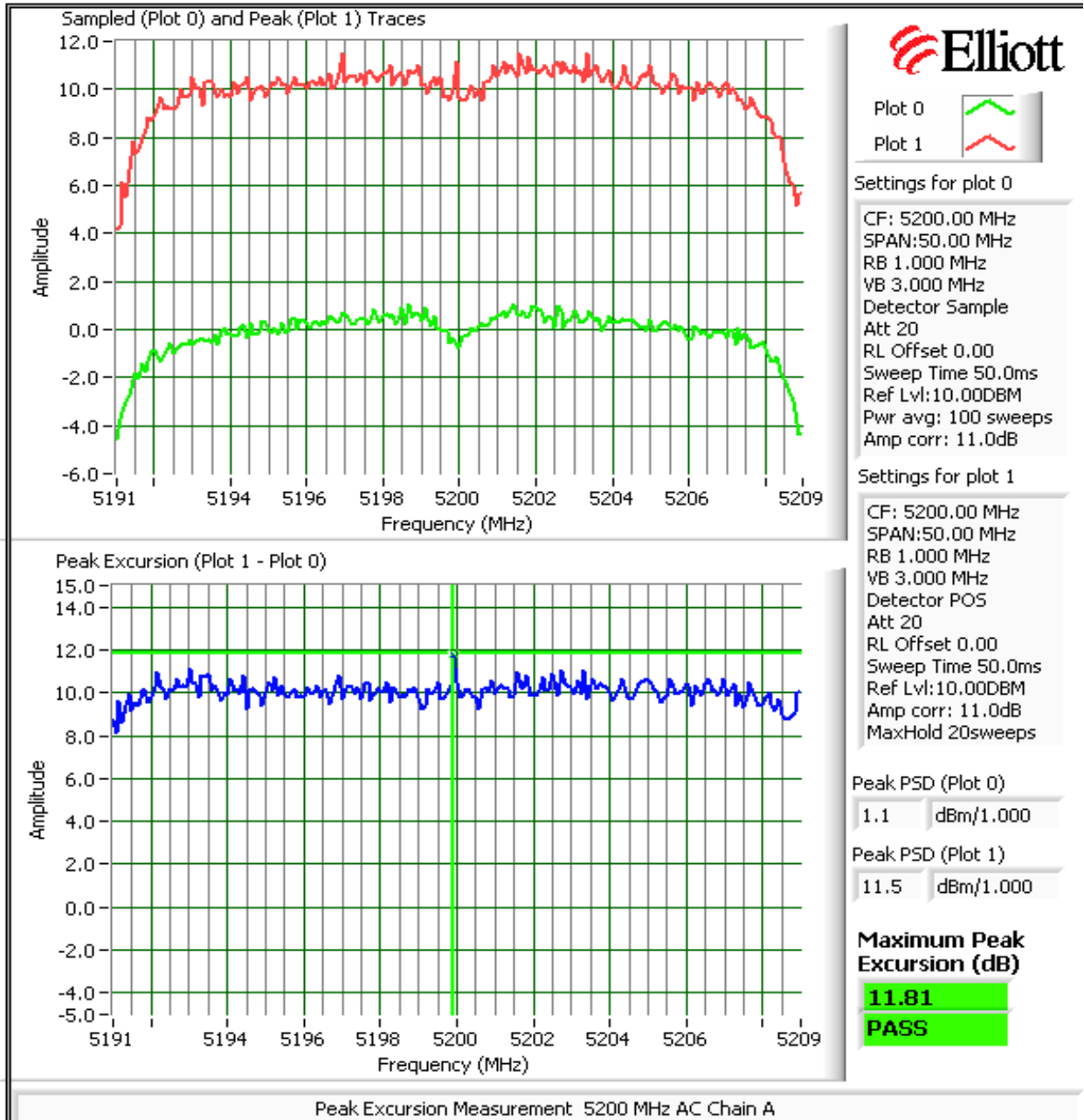

Client: Xirrus	Job Number: J71456
Model: XN16 and XN8	T-Log Number: T71644
	Account Manager: Susan Pezli
Contact: Steve Smith	
Standard: -	Class: N/A

Run #2: Peak Excursion Measurement

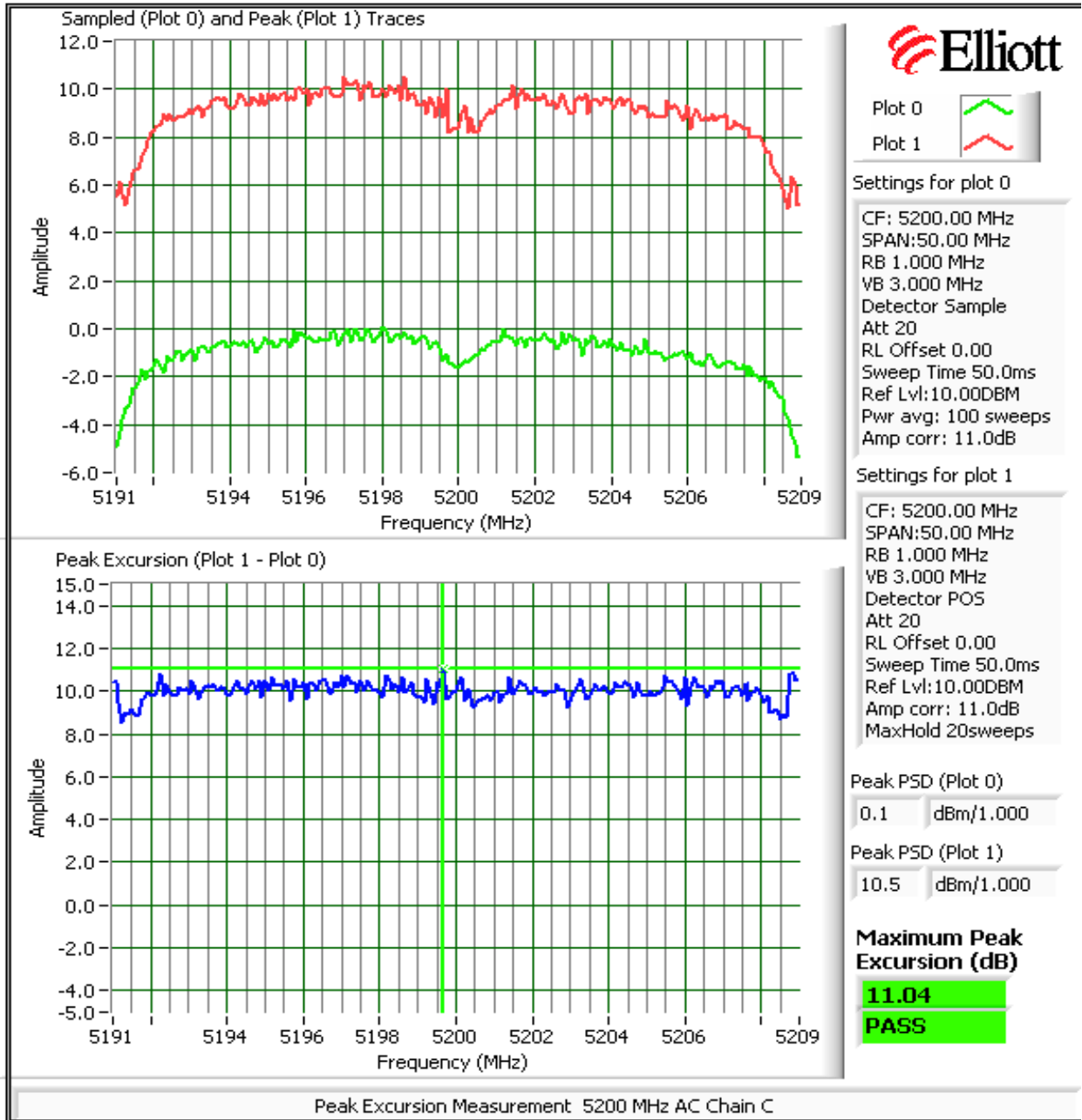

Client: Xirrus	Job Number: J71456
Model: XN16 and XN8	T-Log Number: T71644
Contact: Steve Smith	Account Manager: Susan Pezli
Standard: -	Class: N/A

Run #2: Peak Excursion Measurement

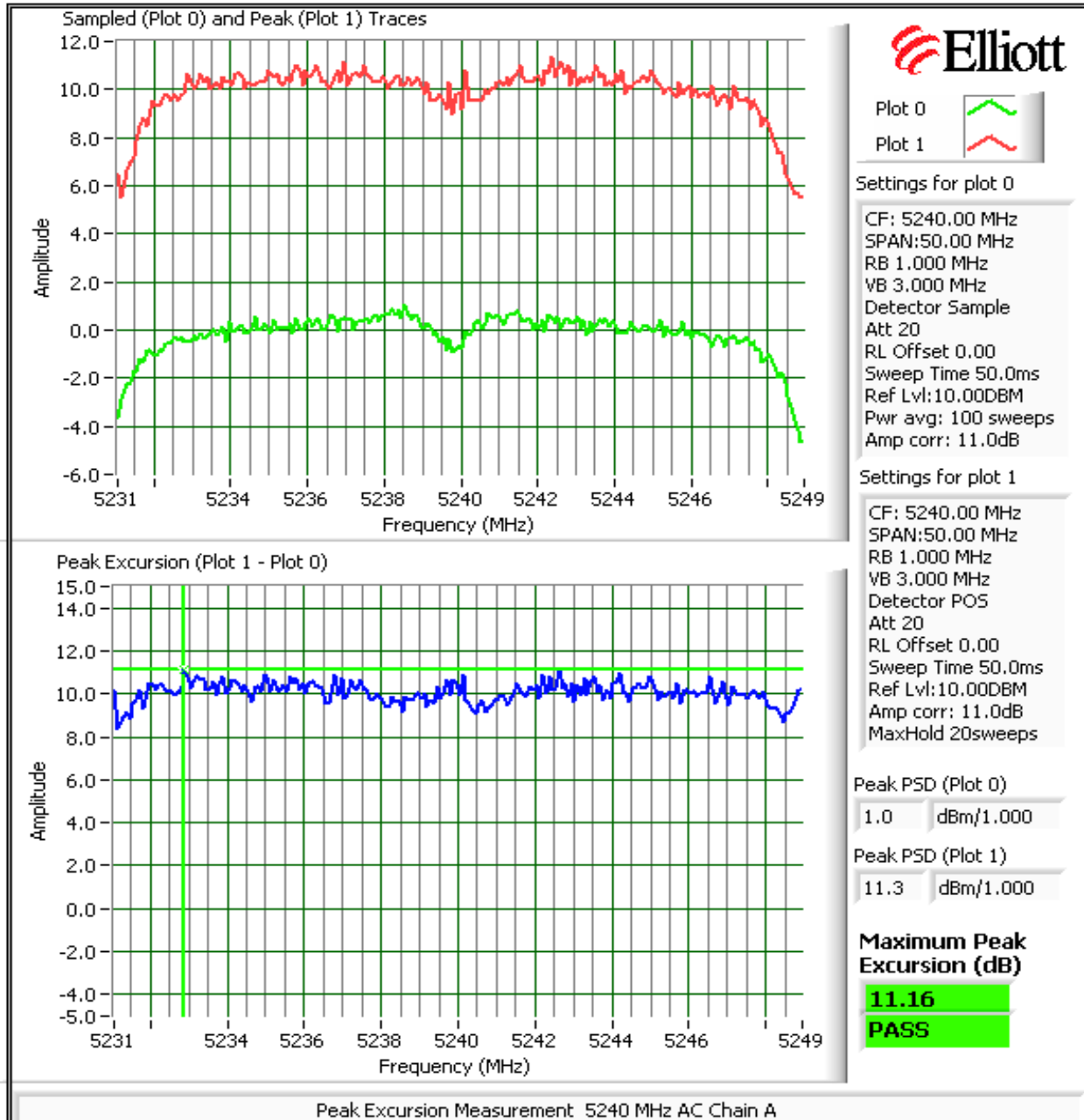

Client: Xirrus	Job Number: J71456
Model: XN16 and XN8	T-Log Number: T71644
Contact: Steve Smith	Account Manager: Susan Pezli
Standard: -	Class: N/A

Run #2: Peak Excursion Measurement

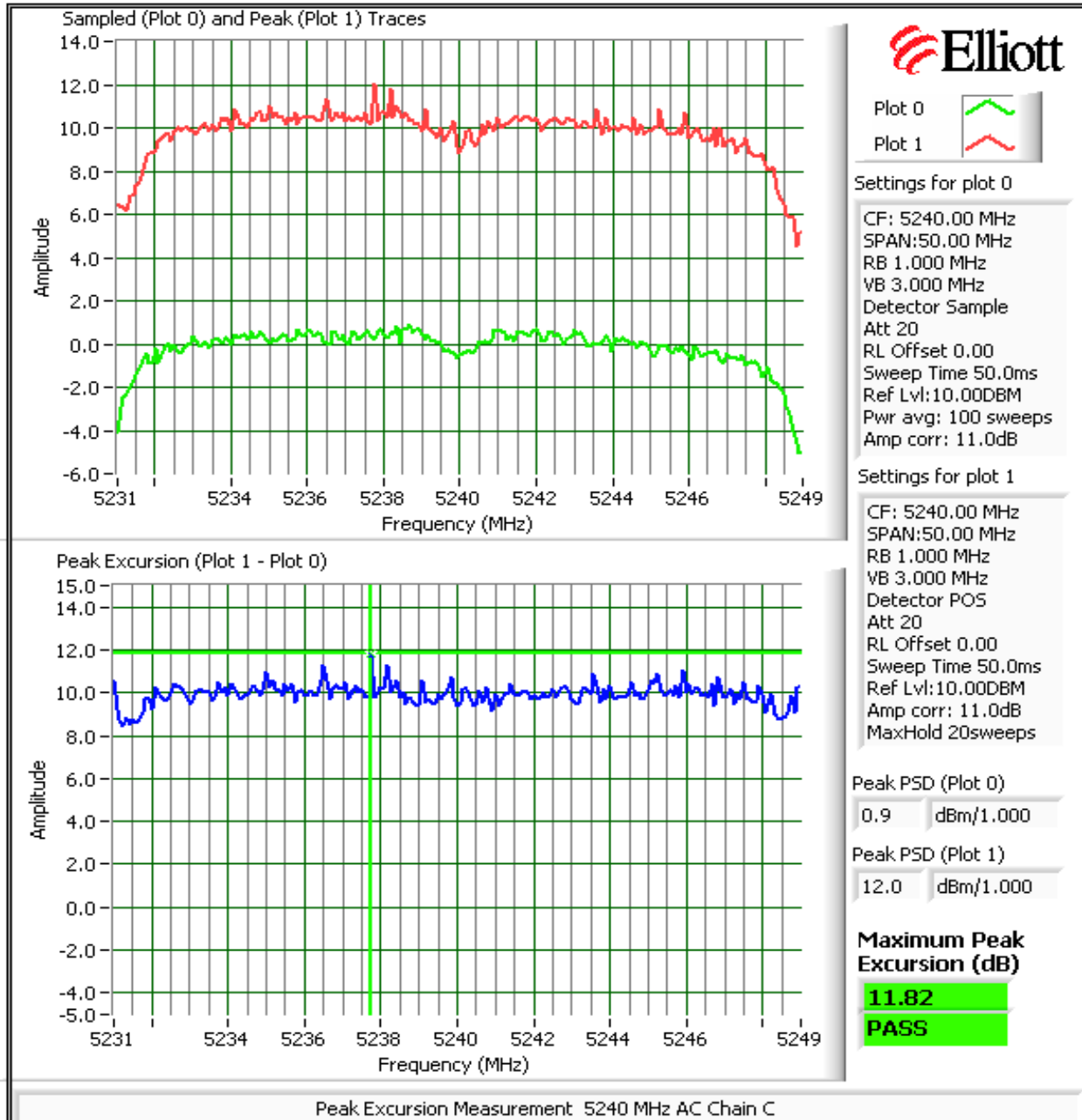

Client: Xirrus	Job Number: J71456
Model: XN16 and XN8	T-Log Number: T71644
Contact: Steve Smith	Account Manager: Susan Pezli
Standard: -	Class: N/A

Run #2: Peak Excursion Measurement

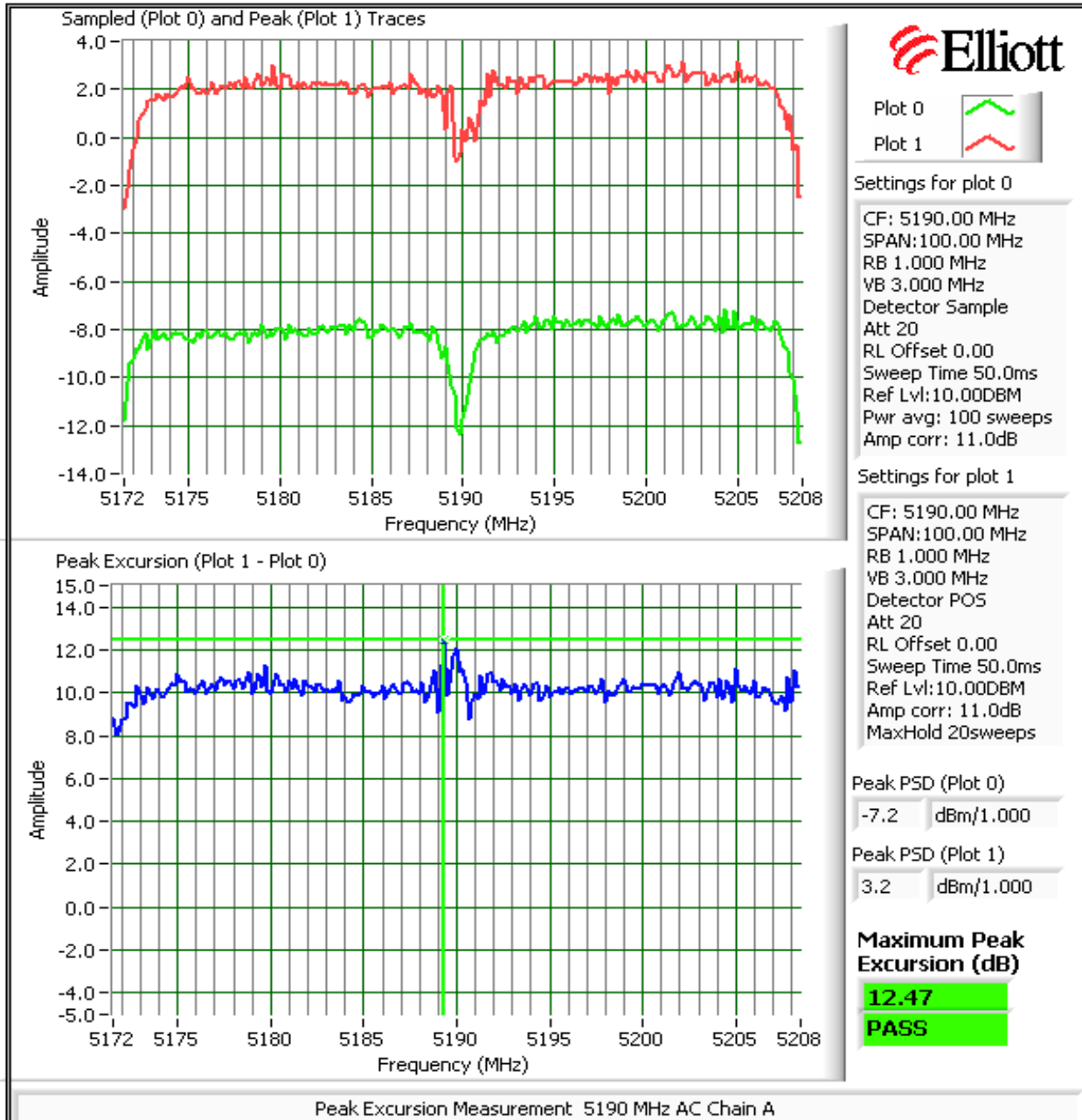

Client: Xirrus	Job Number: J71456
Model: XN16 and XN8	T-Log Number: T71644
Contact: Steve Smith	Account Manager: Susan Pezli
Standard: -	Class: N/A

Run #2: Peak Excursion Measurement

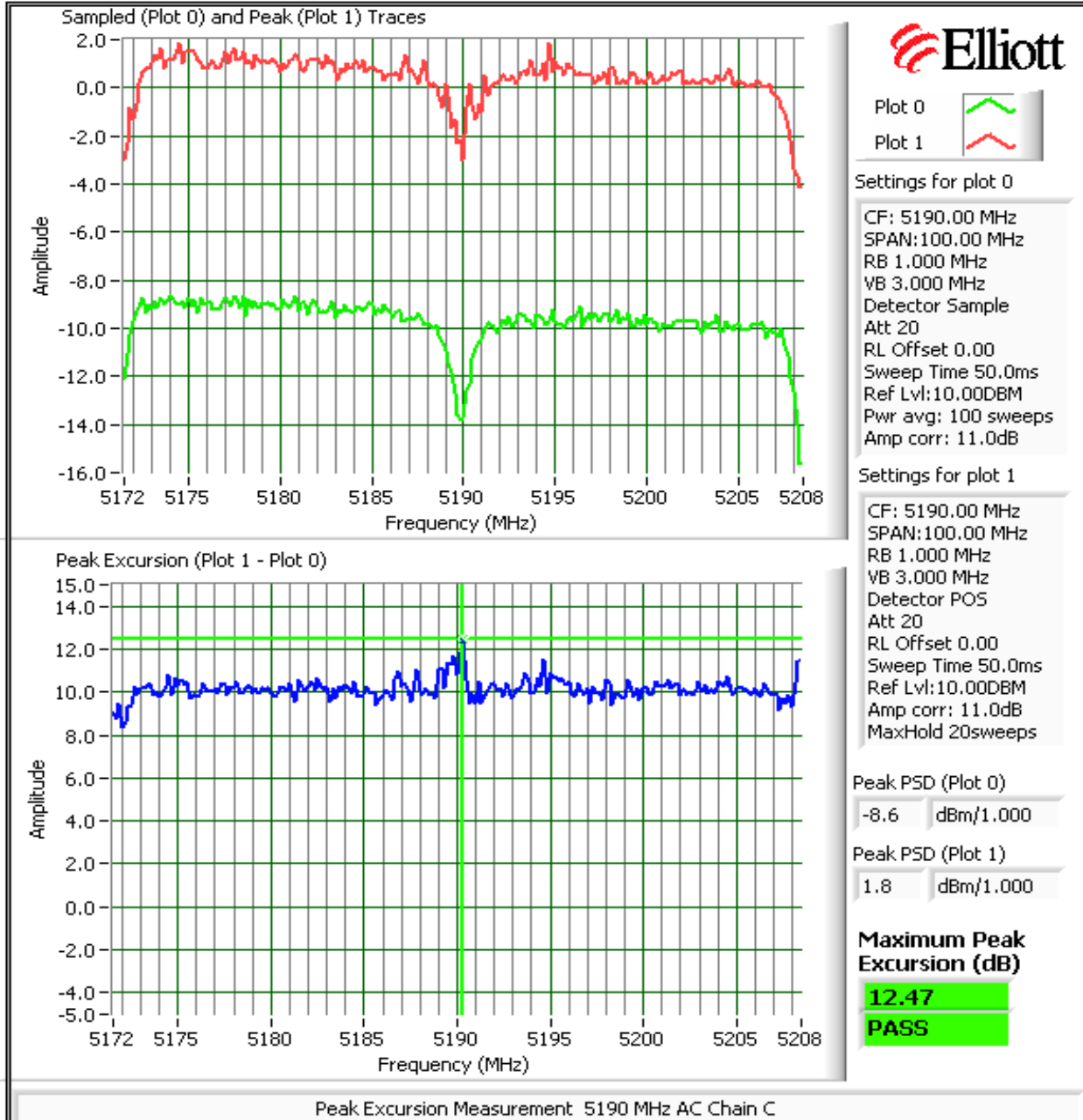

Client: Xirus	Job Number: J71456
Model: XN16 and XN8	T-Log Number: T71644
	Account Manager: Susan Pezli
Contact: Steve Smith	
Standard: -	Class: N/A

Run #2: Peak Excursion Measurement

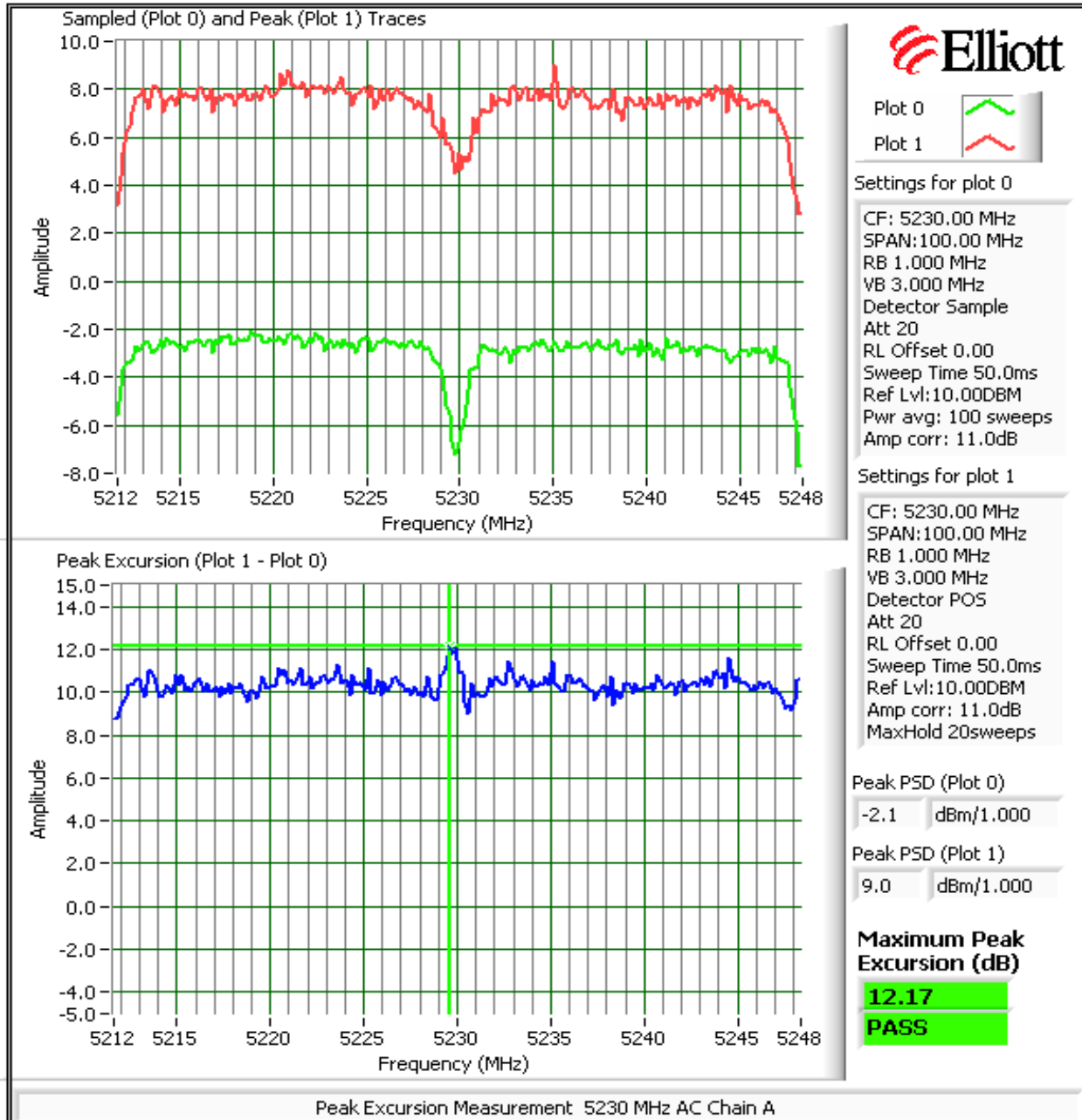

Client: Xirrus	Job Number: J71456
Model: XN16 and XN8	T-Log Number: T71644
Contact: Steve Smith	Account Manager: Susan Pezli
Standard: -	Class: N/A

Run #2: Peak Excursion Measurement

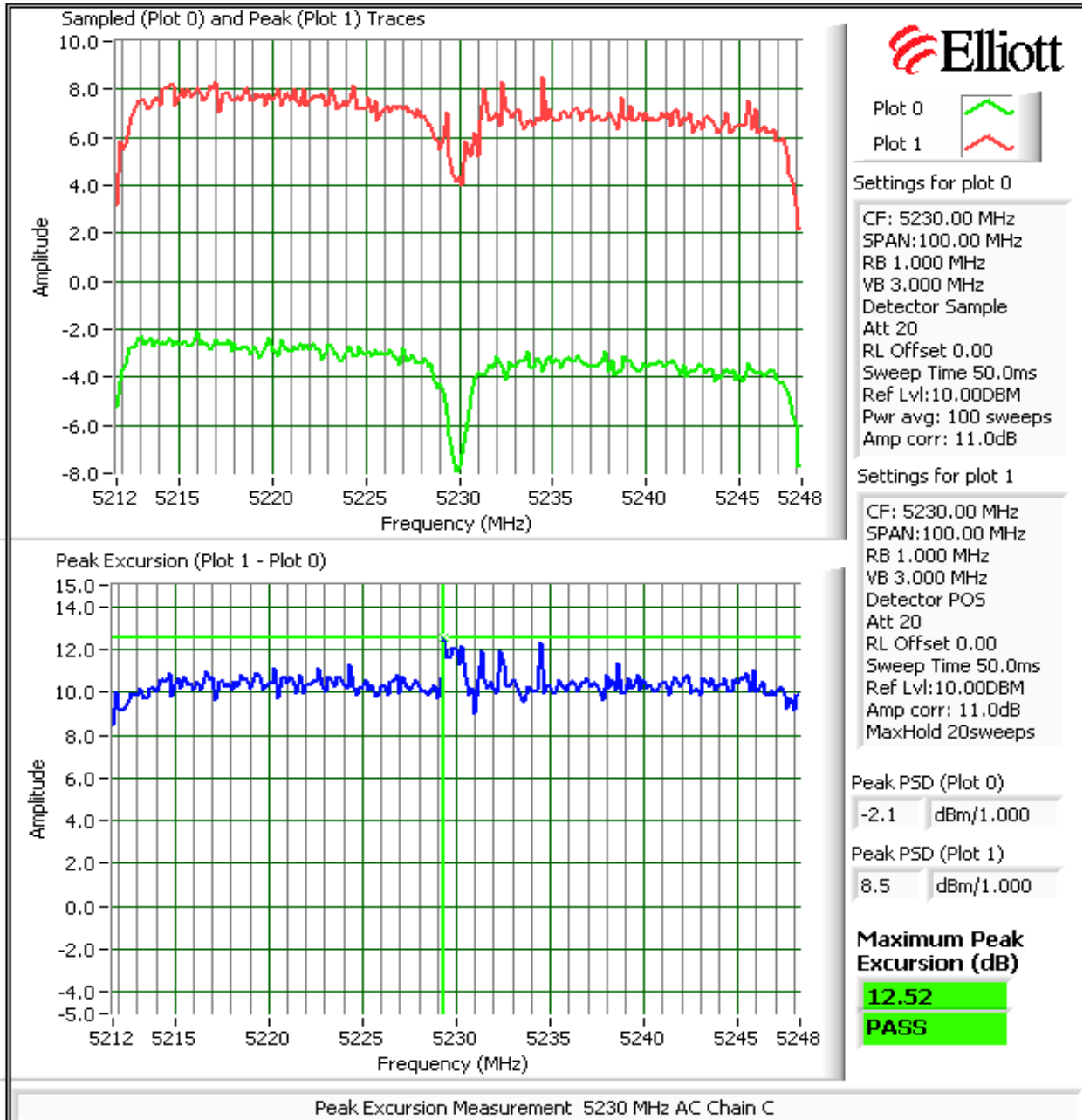

Client: Xirrus	Job Number: J71456
Model: XN16 and XN8	T-Log Number: T71644
	Account Manager: Susan Pelzi
Contact: Steve Smith	
Standard: -	Class: N/A

Run #3: Out Of Band Spurious Emissions - Antenna Conducted

MIMO Devices: Antenna gain used is the effective gain calculated in the power section of this data sheet. The plots were obtained for each chain individually and the limit was adjusted to account for all chains transmitting simultaneously

Number of transmit chains:	2
Maximum Antenna Gain:	9.0 dBi
Spurious Limit:	-27.0 dBm/MHz eirp
Adjustment for 2 chains:	-3.0 dB adjustment for multiple chains.
Limit Used On Plots ^{Note 1:}	-39.0 dBm/MHz Average Limit (RB=1MHz, VB=10Hz)
	-19.0 dBm/MHz Peak Limit (RB=VB=1MHz)

Note 1:	The -27dBm/MHz limit is an eirp limit. The limit for antenna port conducted measurements is adjusted to take into consideration the maximum antenna gain (limit = -27dBm - antenna gain). Radiated field strength measurements for signals more than 50MHz from the bands and that are close to the limit are made to determine compliance as the antenna gain is not known at these frequencies.
Note 2:	All spurious signals below 1GHz are measured during digital device radiated emissions test.
Note 3:	Signals within 10MHz of the 5.725 or 5.825 Band edge are subject to a limit of -17dBm EIRP
Note 4:	If the device is for outdoor use then the -27dBm eirp limit also applies in the 5150 - 5250 MHz band.
Note 5:	Signals that fall in the restricted bands of 15.205 are subject to the limit of 15.209.

Plots Showing Out-Of-Band Emissions (RBW=VBW=1MHz) on Each Chain

802.11n - 20MHz, Low channel, 5150 - 5250 MHz Band (5180 MHz)

Compliance with the radiated limits for the restricted band immediately below 5150MHz is demonstrated through the radiated emissions tests.

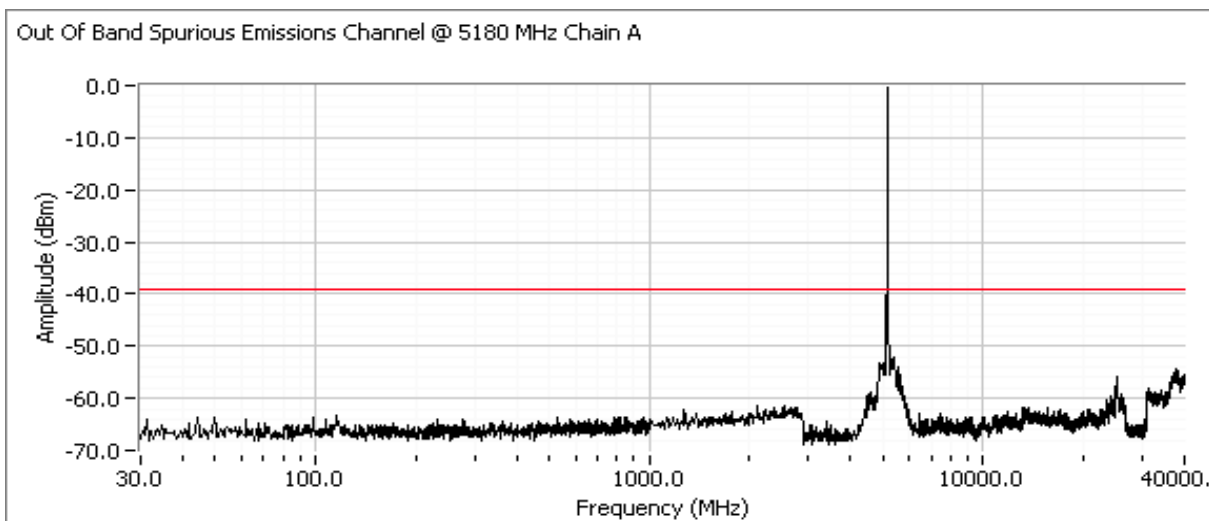

Client: Xirrus	Job Number: J71456
Model: XN16 and XN8	T-Log Number: T71644
	Account Manager: Susan Pezli
Contact: Steve Smith	
Standard: -	Class: N/A

Run #3: Out Of Band Spurious Emissions - Antenna Conducted
802.11n - 20MHz, Low channel, 5150 - 5250 MHz Band (5180 MHz)

Compliance with the radiated limits for the restricted band immediately below 5150MHz is demonstrated through the radiated emissions tests.

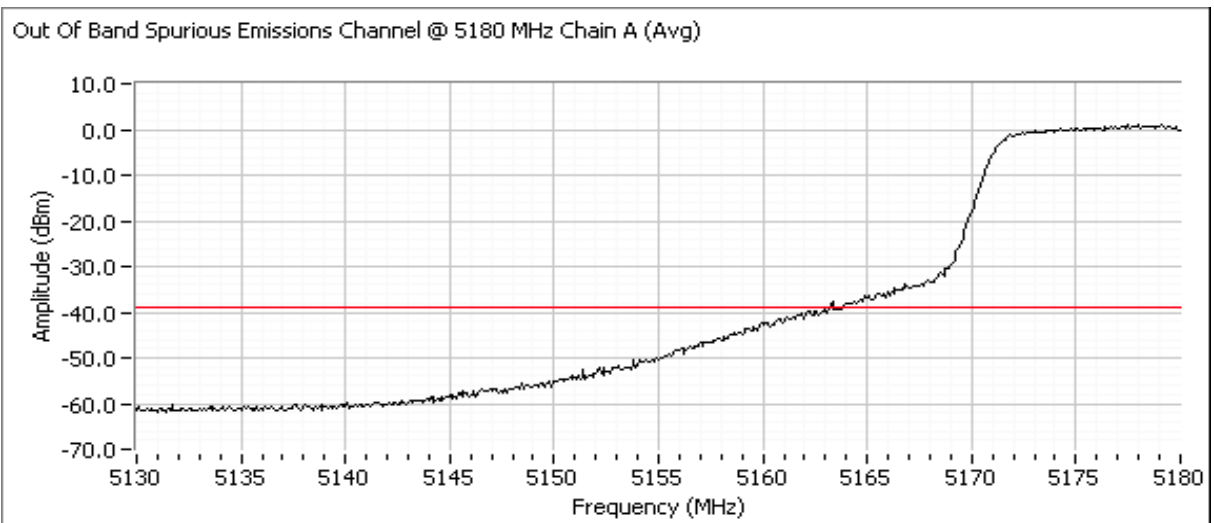
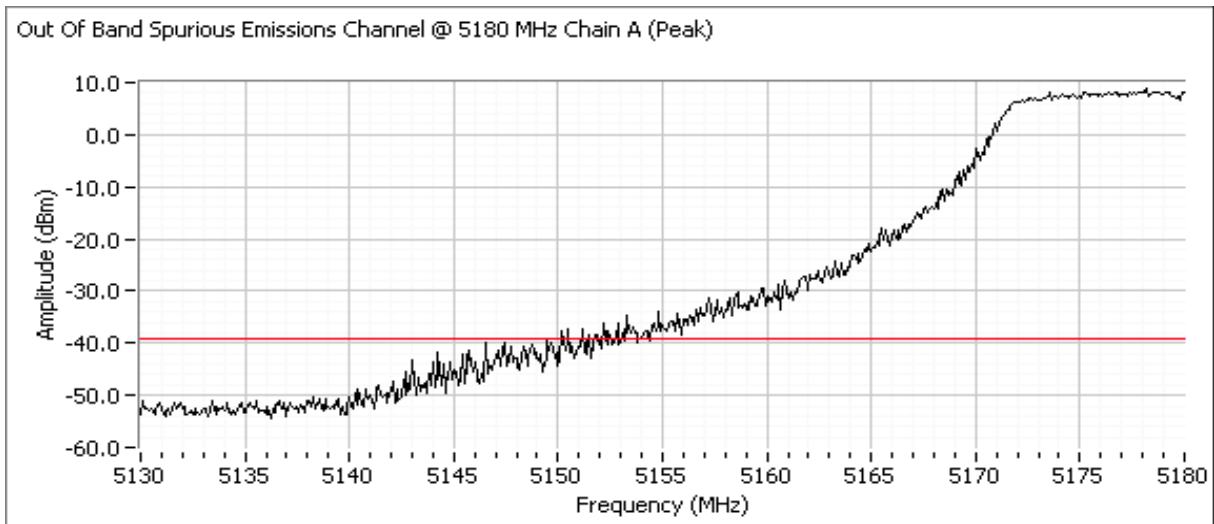

Client: Xirrus	Job Number: J71456
Model: XN16 and XN8	T-Log Number: T71644
	Account Manager: Susan Pezli
Contact: Steve Smith	
Standard: -	Class: N/A

Run #3: Out Of Band Spurious Emissions - Antenna Conducted
802.11n - 20MHz, Low channel, 5150 - 5250 MHz Band (5180 MHz)

Compliance with the radiated limits for the restricted band immediately below 5150MHz is demonstrated through the radiated emissions tests.

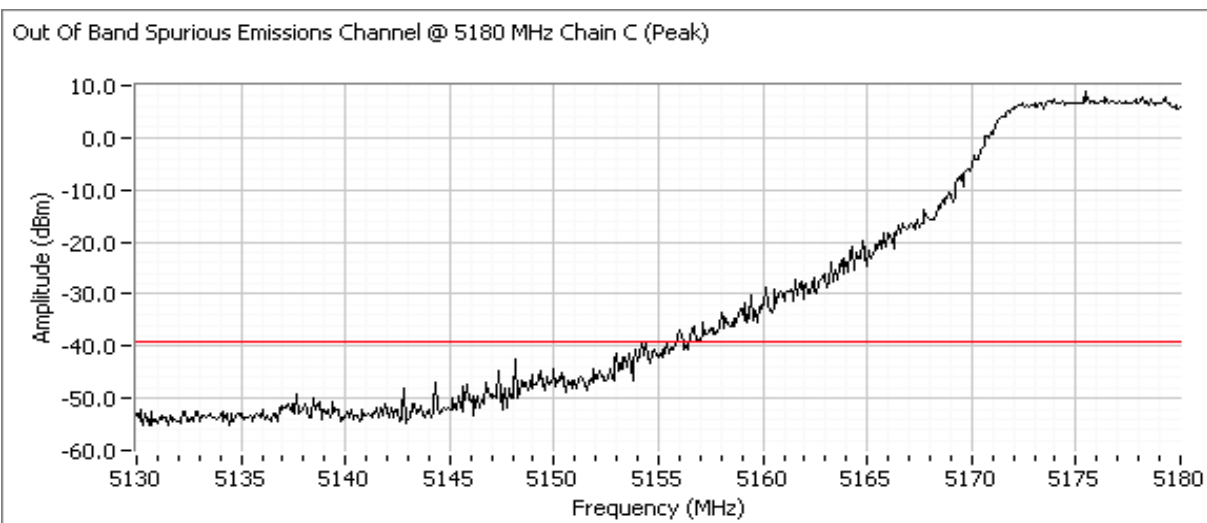
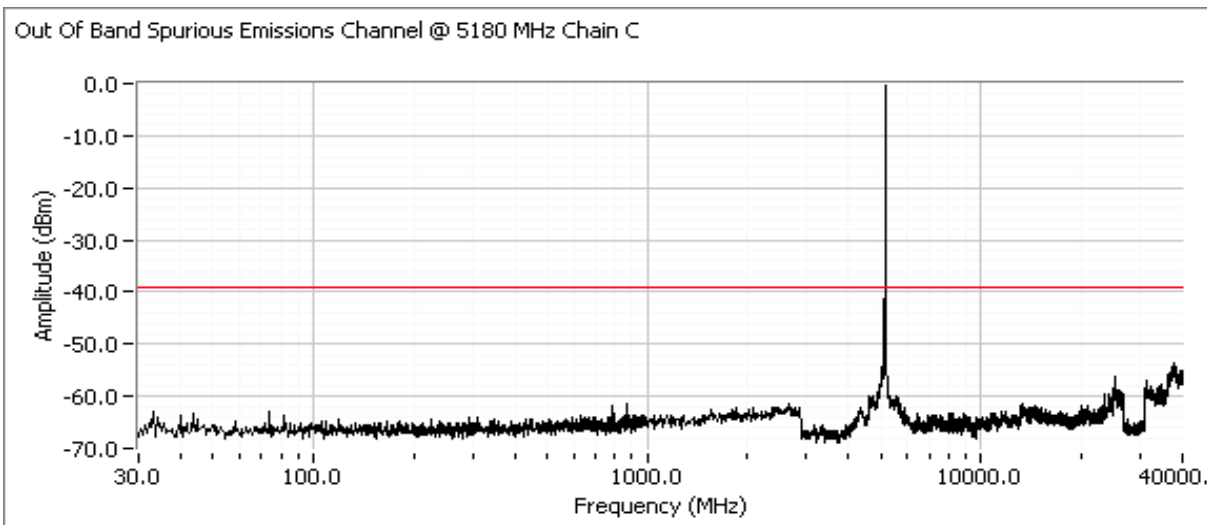

Client: Xirrus	Job Number: J71456
Model: XN16 and XN8	T-Log Number: T71644
	Account Manager: Susan Pezli
Contact: Steve Smith	
Standard: -	Class: N/A

Run #3: Out Of Band Spurious Emissions - Antenna Conducted
802.11n - 20MHz, Low channel, 5150 - 5250 MHz Band (5180 MHz)

Compliance with the radiated limits for the restricted band immediately below 5150MHz is demonstrated through the radiated emissions tests.

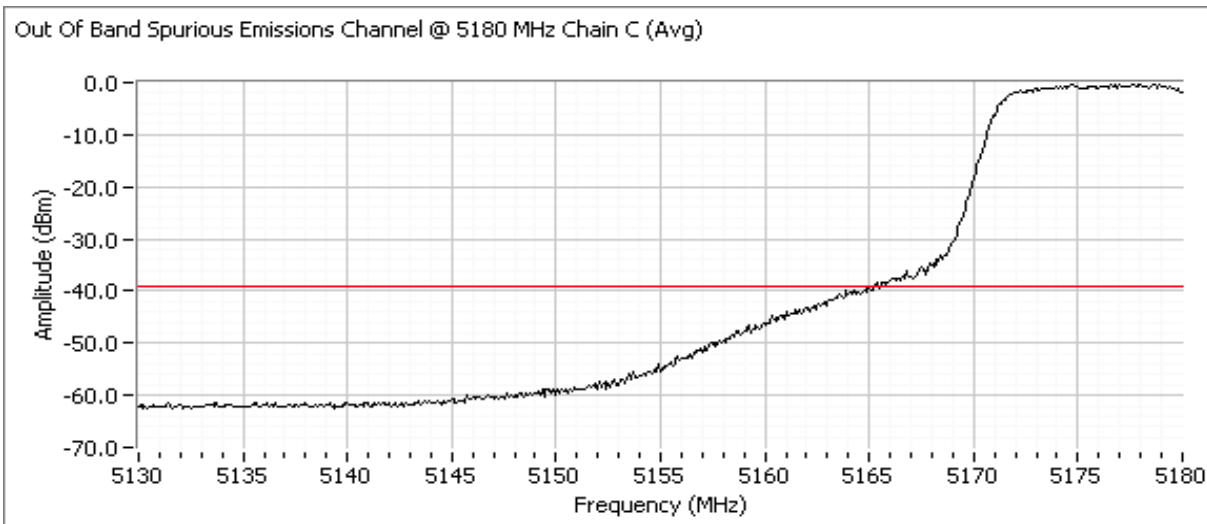

802.11n - 20MHz, Center channel, 5150 - 5250 MHz Band (5200 MHz)

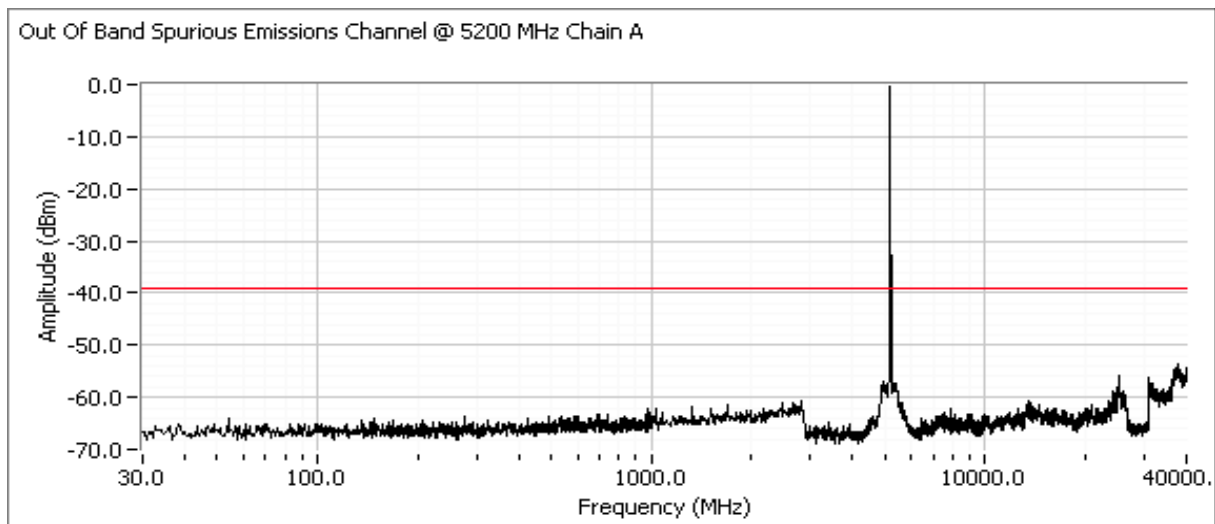

Client: Xirrus	Job Number: J71456
Model: XN16 and XN8	T-Log Number: T71644
Contact: Steve Smith	Account Manager: Susan Pezli
Standard: -	Class: N/A

Run #3: Out Of Band Spurious Emissions - Antenna Conducted
802.11n - 20MHz, Center channel, 5150 - 5250 MHz Band (5200 MHz)

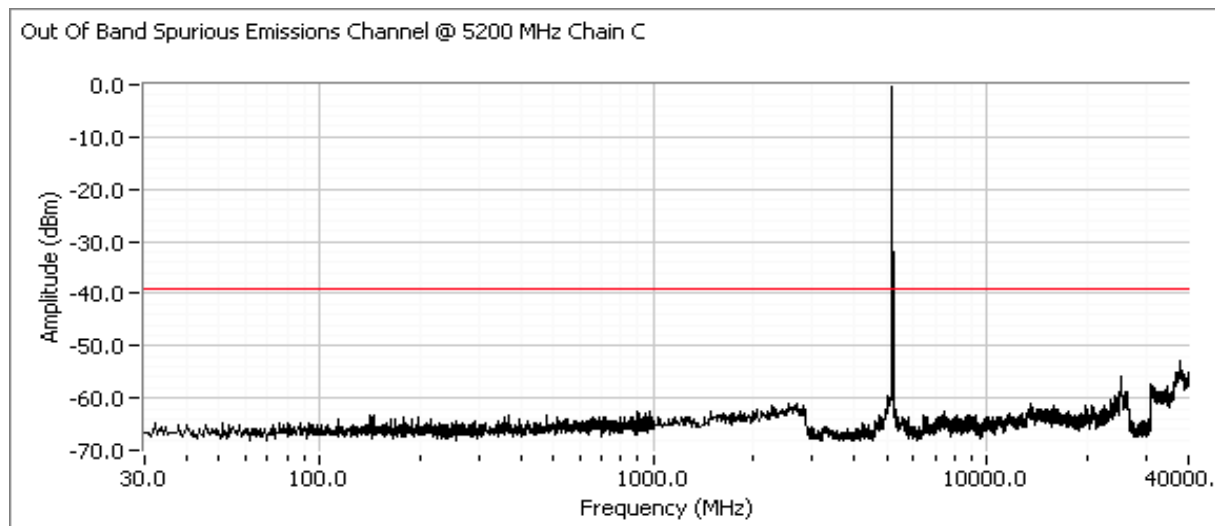

802.11n - 20MHz, High channel, 5150 - 5250 MHz Band (5240 MHz)

Note; Initial approval for FCC will only allow operation in the 5150 - 5250 MHz NII band so a plot showing -20dBc at 5250 MHz and above is included.

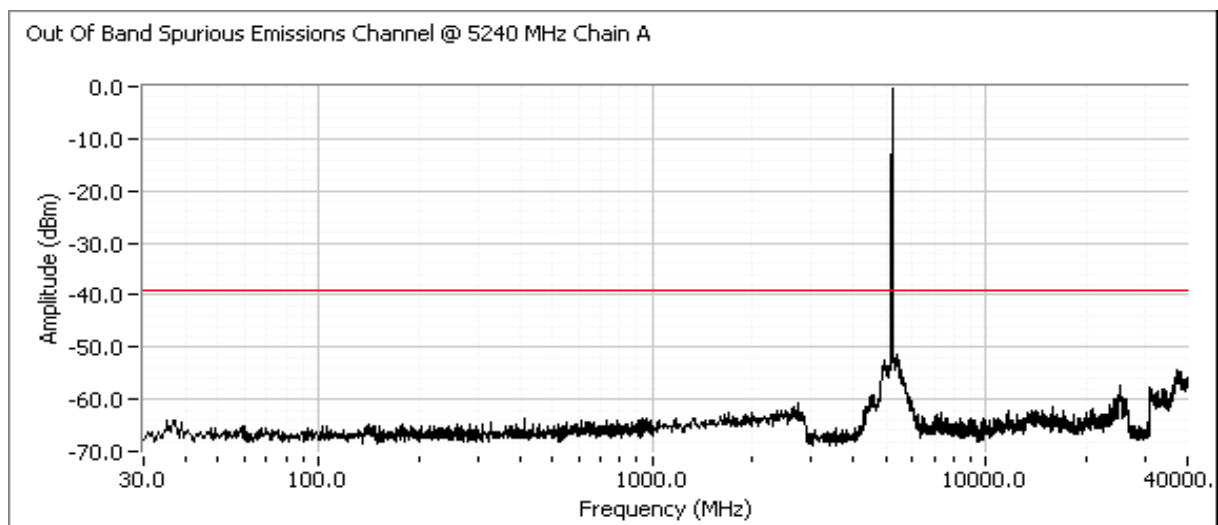

Client: Xirrus	Job Number: J71456
Model: XN16 and XN8	T-Log Number: T71644
Contact: Steve Smith	Account Manager: Susan Pezli
Standard: -	Class: N/A

Run #3: Out Of Band Spurious Emissions - Antenna Conducted
802.11n - 20MHz, High channel, 5150 - 5250 MHz Band (5240 MHz)

Note: Initial approval for FCC will only allow operation in the 5150 - 5250 MHz NII band so a plot showing -20dBc at 5250 MHz and above is included.

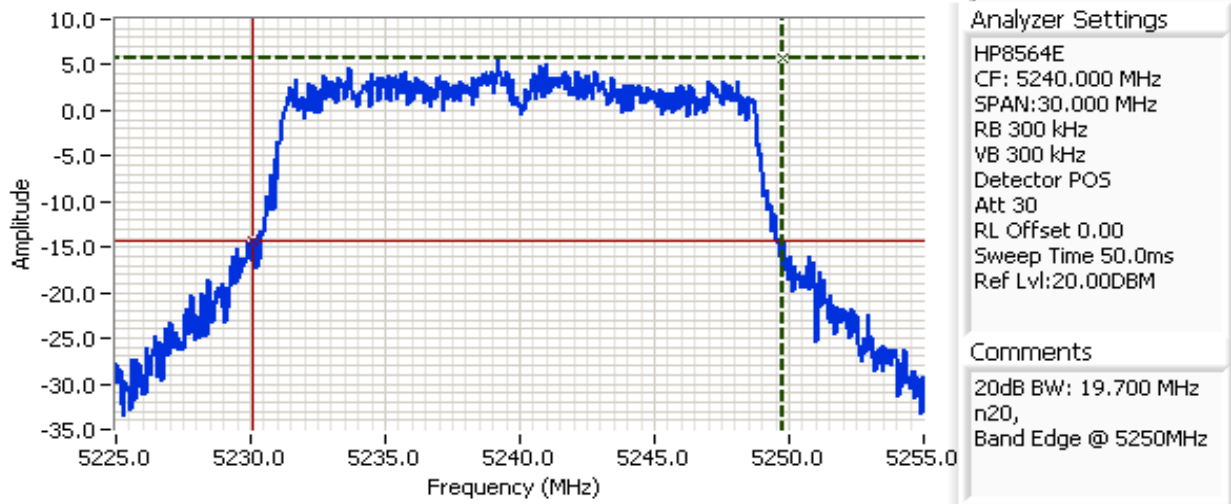

Cursor 1	5249.8000	5.67		Delta Freq.	19.700	
Cursor 2	5230.1000	-14.33		Delta Amplitude	20.00	

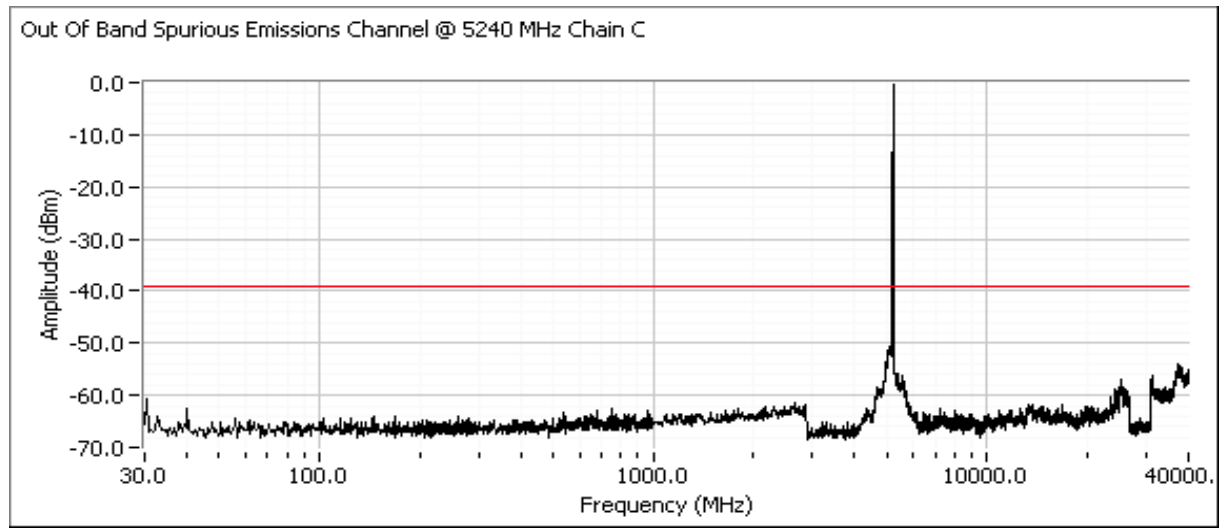

Client: Xirrus	Job Number: J71456
Model: XN16 and XN8	T-Log Number: T71644
Contact: Steve Smith	Account Manager: Susan Pezli
Standard: -	Class: N/A

Run #3: Out Of Band Spurious Emissions - Antenna Conducted
802.11n - 20MHz, High channel, 5150 - 5250 MHz Band (5240 MHz)

Note: Initial approval for FCC will only allow operation in the 5150 - 5250 MHz NII band so a plot showing -20dBc at 5250 MHz and above is included.

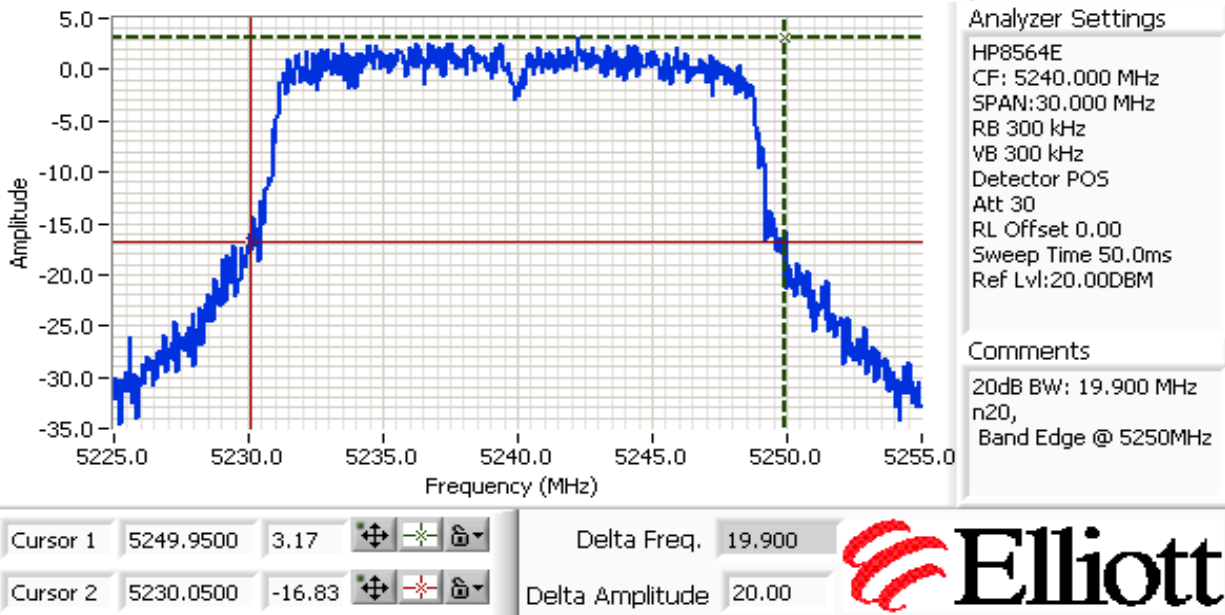

802.11n - 40MHz, Low channel, 5150 - 5250 MHz Band (5190 MHz)

Compliance with the radiated limits for the restricted band immediately below 5150MHz is demonstrated through the radiated emissions tests.

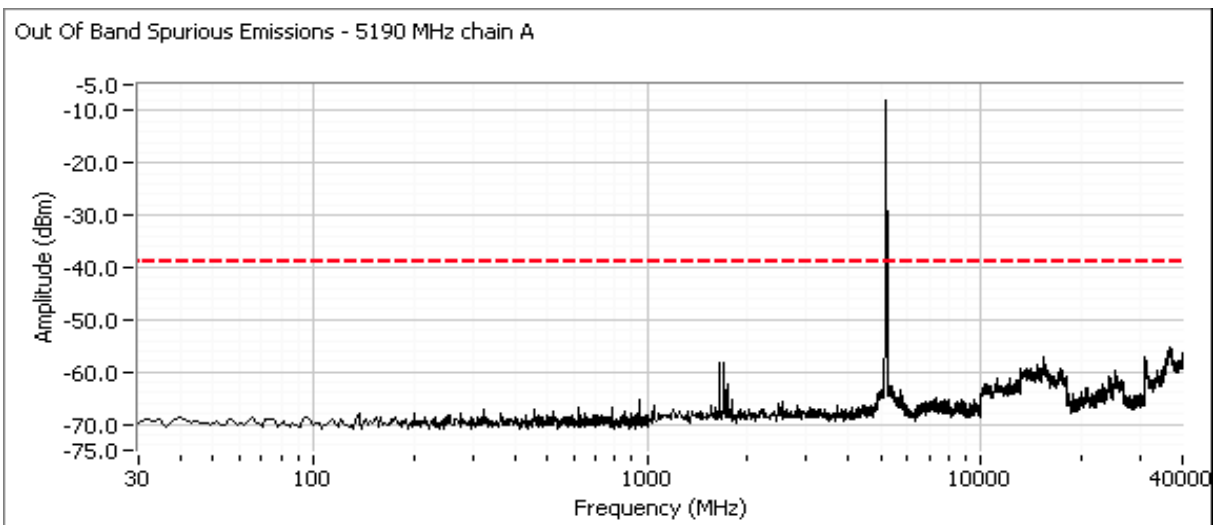

Client: Xirrus	Job Number: J71456
Model: XN16 and XN8	T-Log Number: T71644
	Account Manager: Susan Pezli
Contact: Steve Smith	
Standard: -	Class: N/A

802.11n - 40MHz, Low channel, 5150 - 5250 MHz Band (5190 MHz)

Compliance with the radiated limits for the restricted band immediately below 5150MHz is demonstrated through the radiated emissions tests.

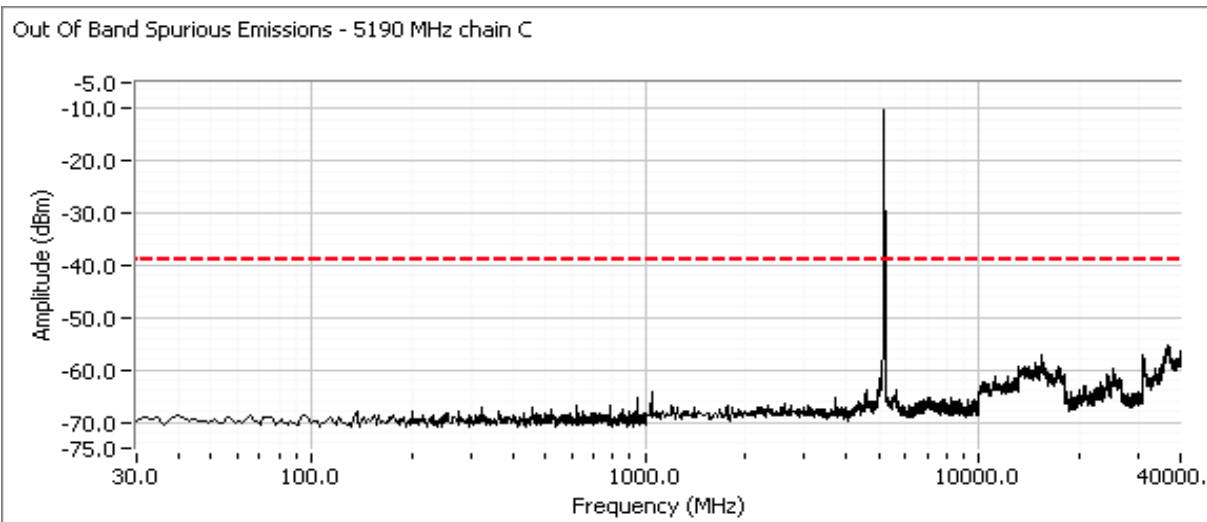
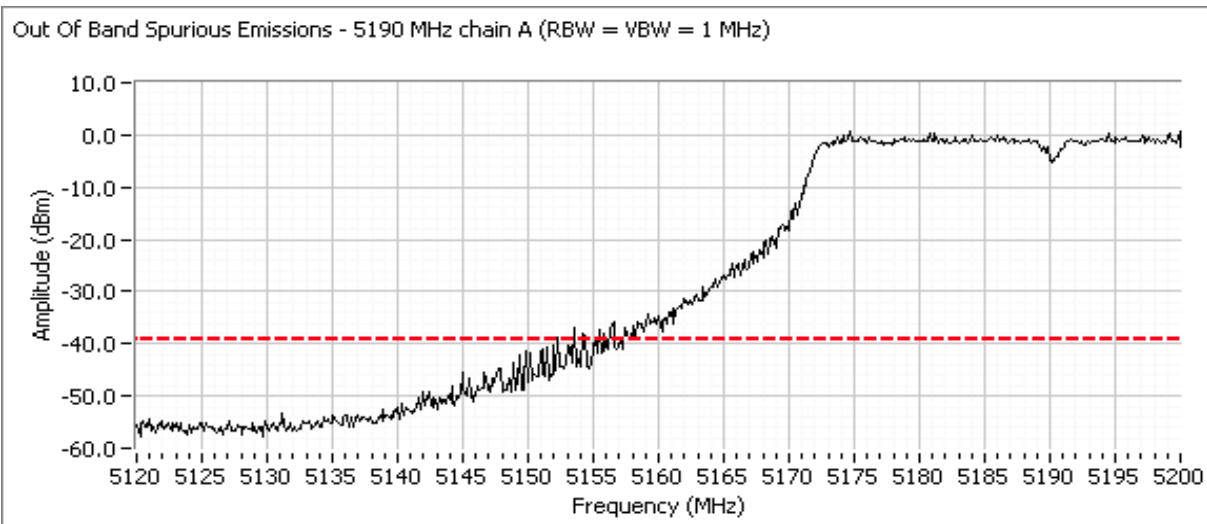

Client: Xirrus	Job Number: J71456
Model: XN16 and XN8	T-Log Number: T71644
	Account Manager: Susan Pezli
Contact: Steve Smith	
Standard: -	Class: N/A

802.11n - 40MHz, Low channel, 5150 - 5250 MHz Band (5190 MHz)

Compliance with the radiated limits for the restricted band immediately below 5150MHz is demonstrated through the radiated emissions tests.

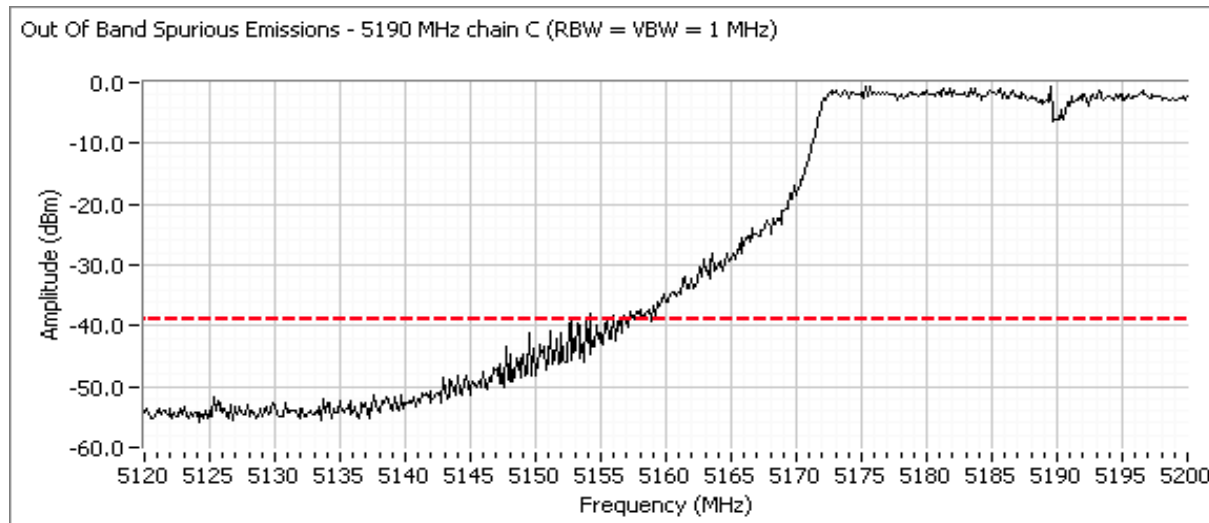
802.11n - 40MHz, High channel, 5150 - 5250 MHz Band (5230 MHz)

Note; Initial approval for FCC will only allow operation in the 5150 - 5250 MHz NII band so a plot showing -20dBc at 5250 MHz and above is included.

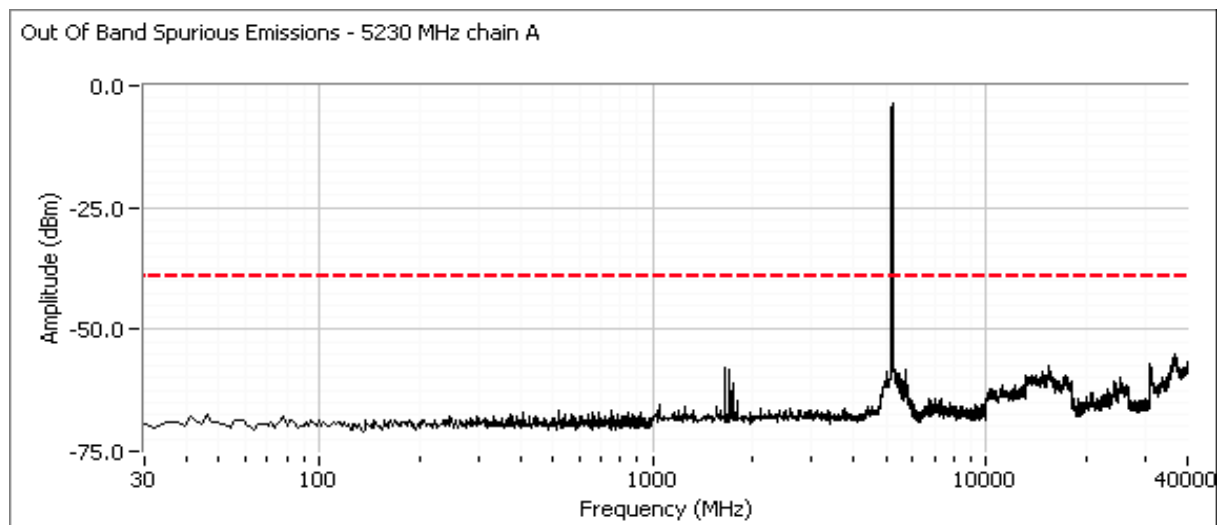

Client: Xirrus	Job Number: J71456
Model: XN16 and XN8	T-Log Number: T71644
	Account Manager: Susan Pezli
Contact: Steve Smith	
Standard: -	Class: N/A

802.11n - 40MHz, High channel, 5150 - 5250 MHz Band (5230 MHz)

Note; Initial approval for FCC will only allow operation in the 5150 - 5250 MHz NII band so a plot showing -20dBc at 5250 MHz and above is included.

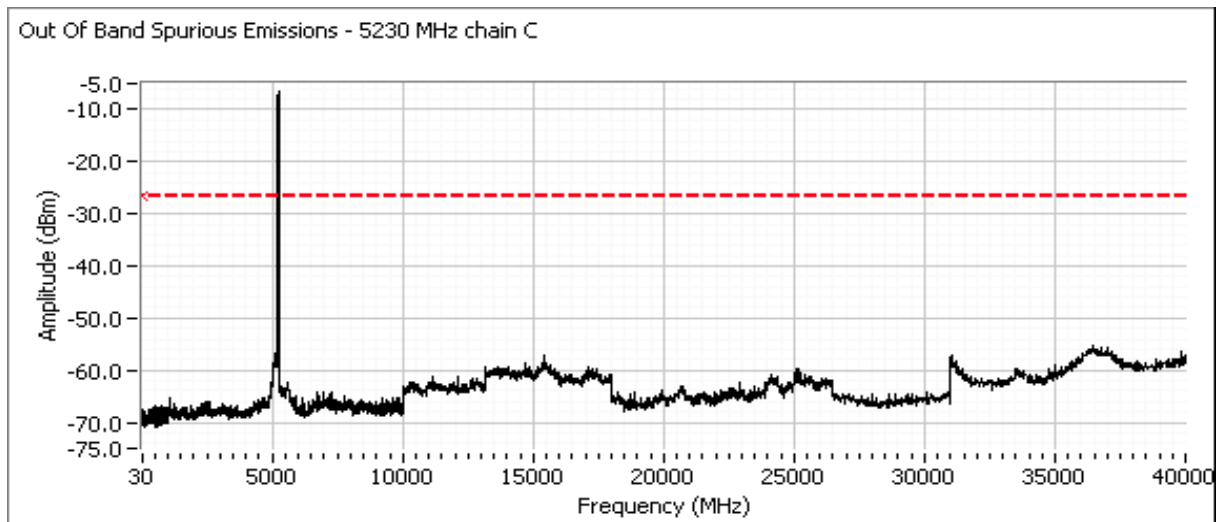
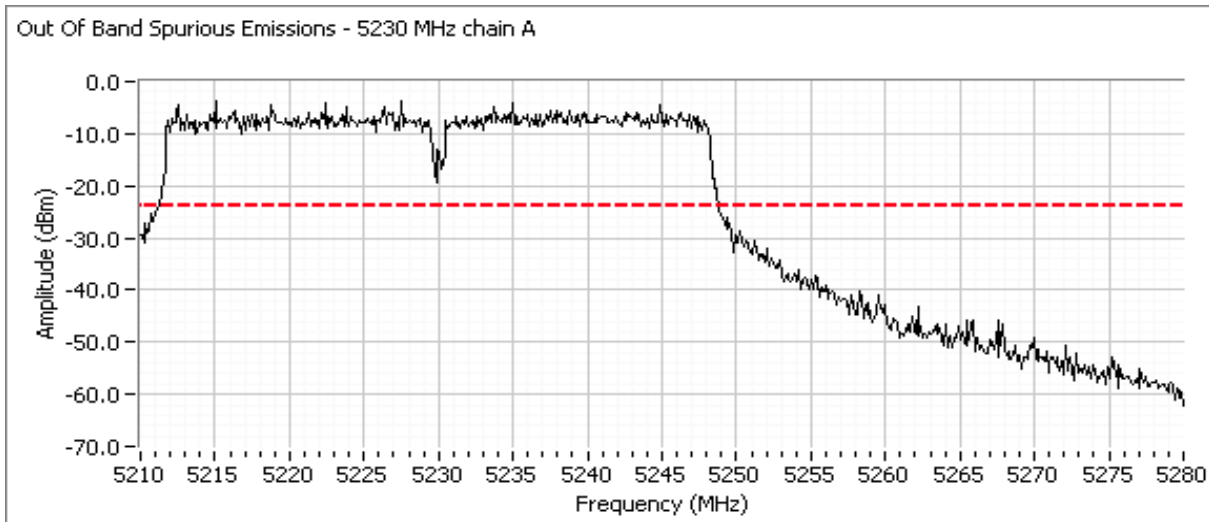

Client: Xirrus	Job Number: J71456
Model: XN16 and XN8	T-Log Number: T71644
	Account Manager: Susan Pezli
Contact: Steve Smith	
Standard: -	Class: N/A

802.11n - 40MHz, High channel, 5150 - 5250 MHz Band (5230 MHz)

Note; Initial approval for FCC will only allow operation in the 5150 - 5250 MHz NII band so a plot showing -20dBc at 5250 MHz and above is included.

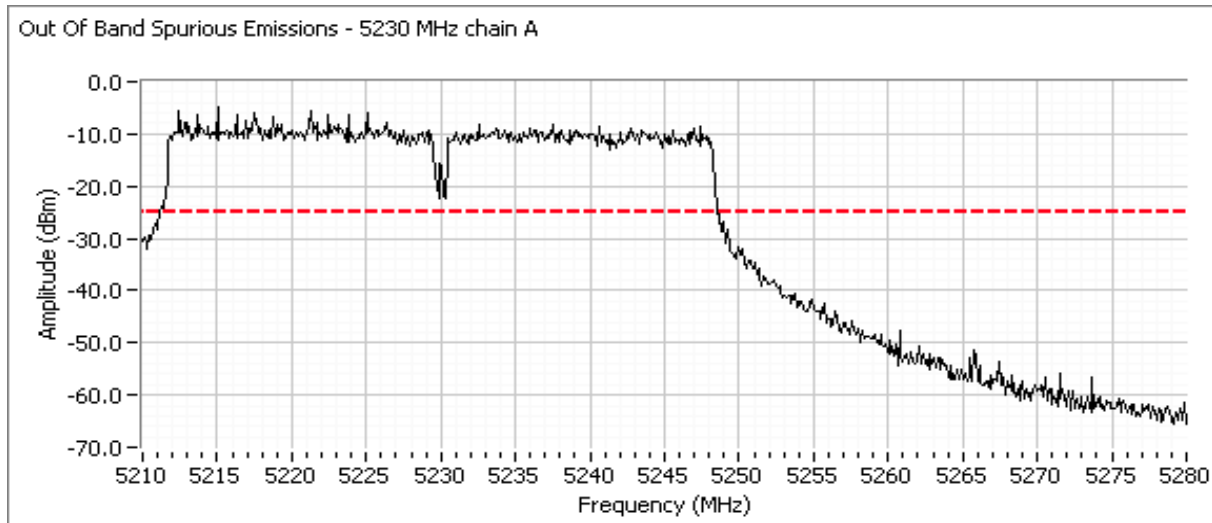



EMC Test Data

Client:	Xirrus	Job Number:	J71456
Model:	XN16 and XN8	T-Log Number:	T71642
		Account Manager:	Susan Pelzl
Contact:	Steve Smith		Mark Briggs
Emissions Standard(s):	FCC 15.247 / RSS 210	Class:	UNII
Immunity Standard(s):	-	Environment:	Wireless

EMC Test Data

For The

Xirrus

Model

XN16 and XN8

Date of Last Test: 6/2/2008

Client: Xirus	Job Number: J71456
Model: XN16 and XN8	T-Log Number: T71642
	Account Manager: Susan Pelzl
Contact: Steve Smith	
Standard: FCC 15.247 / RSS 210	Class: N/A

**RSS 210 and FCC 15.407 (UNII - 5150 - 5250 MHz)
Radiated Spurious Emissions, Band Edges - External Antenna**

Test Specific Details

Objective: The objective of this test session is to perform final qualification testing of the EUT with respect to the specification listed above.

Date of Test: 5/28/2008
 Test Engineer: Suhaila Khushzad
 Test Location: SVOATS #1

Config. Used: 1
 Config Change: None
 EUT Voltage: POE

General Test Configuration

The EUT and all local support equipment were located on the turntable for radiated spurious emissions testing. All remote support equipment was located approximately 30 meters from the EUT with all I/O connections running on top of the groundplane.

For radiated emissions testing the measurement antenna was located 3 meters from the EUT.

Ambient Conditions: Temperature: 19 °C
 Rel. Humidity: 50 %

Summary of Results

Run #	Mode	Channel	Power Setting	Test Performed	Limit	Result / Margin
1a	802.11a Chain A	5180 MHz	17.0	Restricted Band Edge at 5150 MHz	15.209	52.2dBµV/m @ 5150.0MHz (-1.8dB)

Modifications Made During Testing

No modifications were made to the EUT during testing

Deviations From The Standard

No deviations were made from the requirements of the standard.

Client: Xirrus	Job Number: J71456
Model: XN16 and XN8	T-Log Number: T71642
Contact: Steve Smith	Account Manager: Susan Pelzl
Standard: FCC 15.247 / RSS 210	Class: N/A

Run #1, Radiated Spurious Emissions, 30 - 40,000 MH. Operation in the 5150-5250 MHz Band
 Run #1a: 5180 MHz, 802.11a, Chain A with power setting of 17.0 dBm, External Antenna

5150 MHz Band Edge Signal Radiated Field Strength

Frequency MHz	Level dB μ V/m	Pol V/H	FCC 15.209		Detector Pk/QP/Avg	Azimuth degrees	Height meters	Comments
			Limit	Margin				
5149.950	52.2	V	54.0	-1.8	Avg	301	2.1	RB 1.000 MHz; VB: 10 Hz
5149.670	50.4	H	54.0	-3.6	Avg	278	2.3	RB 1.000 MHz; VB: 10 Hz
5149.820	68.6	V	74.0	-5.4	Pk	301	2.2	RB 1.000 MHz; VB: 1.000 MHz
5147.910	63.6	H	74.0	-10.4	Pk	278	2.3	RB 1.000 MHz; VB: 1.000 MHz

Note 1: For emissions in restricted band immediately below 5150MHz, the limit of 15.209 was used.

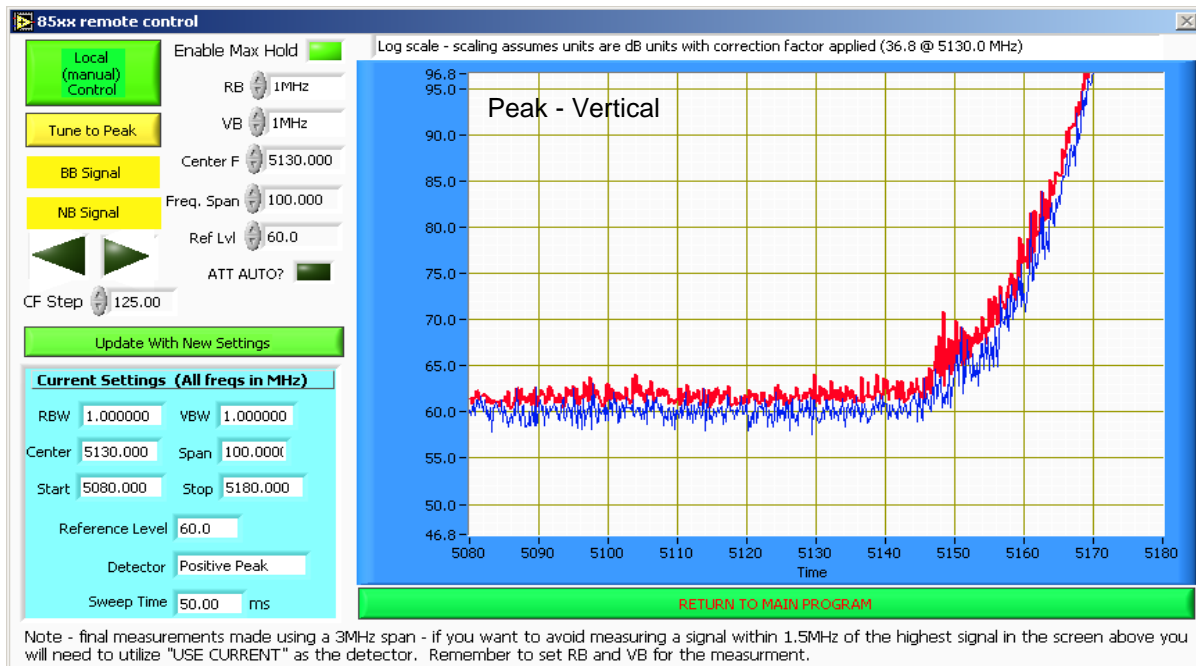

Client: Xirus	Job Number: J71456
Model: XN16 and XN8	T-Log Number: T71642
Contact: Steve Smith	Account Manager: Susan Pelzl
Standard: FCC 15.247 / RSS 210	Class: N/A

Run #1, Radiated Spurious Emissions, 30 - 40,000 MH. Operation in the 5150-5250 MHz Band
 Run #1a: 5180 MHz, 802.11a, Chain A with power setting of 17.0 dBm, External Antenna

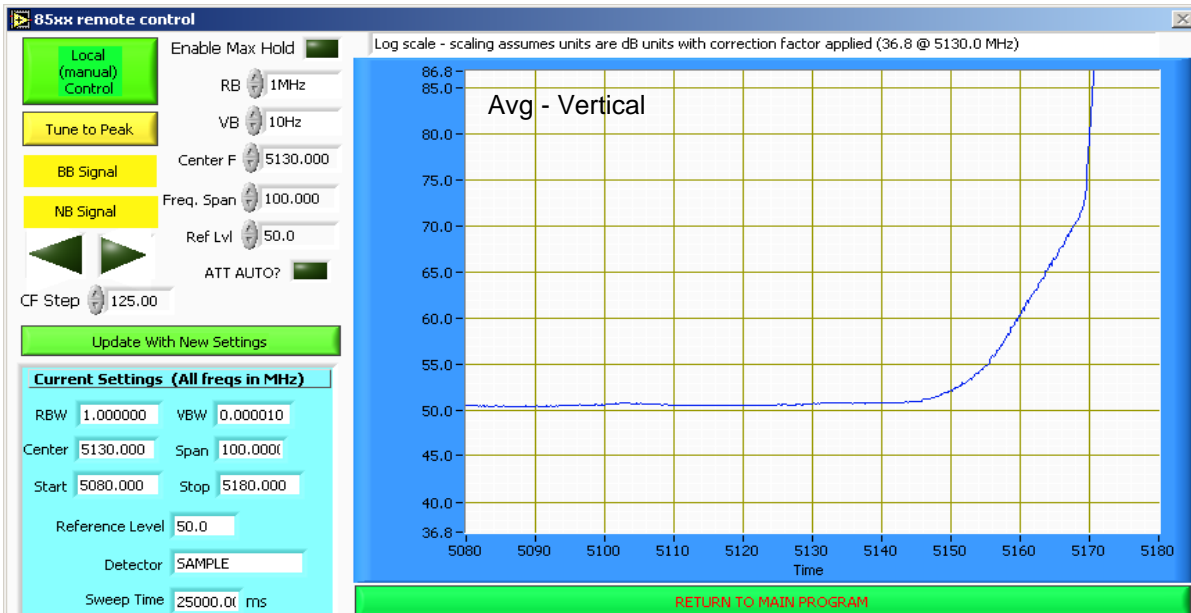

Note - final measurements made using a 3MHz span - if you want to avoid measuring a signal within 1.5MHz of the highest signal in the screen above you will need to utilize "USE CURRENT" as the detector. Remember to set RB and VB for the measurement.

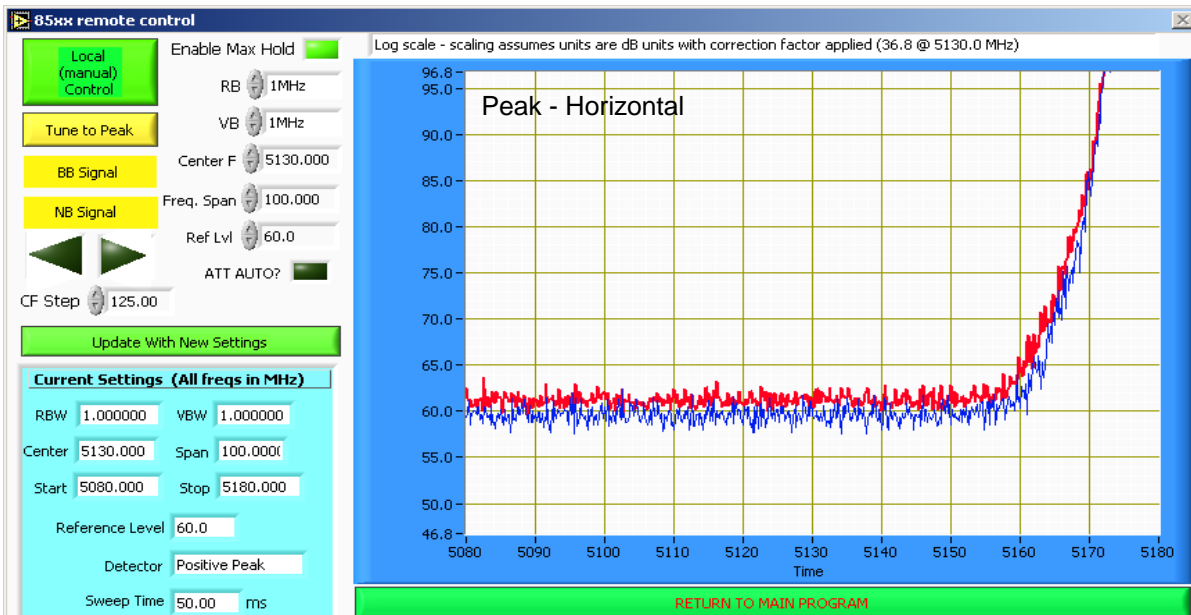

Note - final measurements made using a 3MHz span - if you want to avoid measuring a signal within 1.5MHz of the highest signal in the screen above you will need to utilize "USE CURRENT" as the detector. Remember to set RB and VB for the measurement.

Client: Xirrus	Job Number: J71456
Model: XN16 and XN8	T-Log Number: T71642
Contact: Steve Smith	Account Manager: Susan Pelzl
Standard: FCC 15.247 / RSS 210	Class: N/A

Run #1, Radiated Spurious Emissions, 30 - 40,000 MH. Operation in the 5150-5250 MHz Band
 Run #1a: 5180 MHz, 802.11a, Chain A with power setting of 17.0 dBm, External Antenna

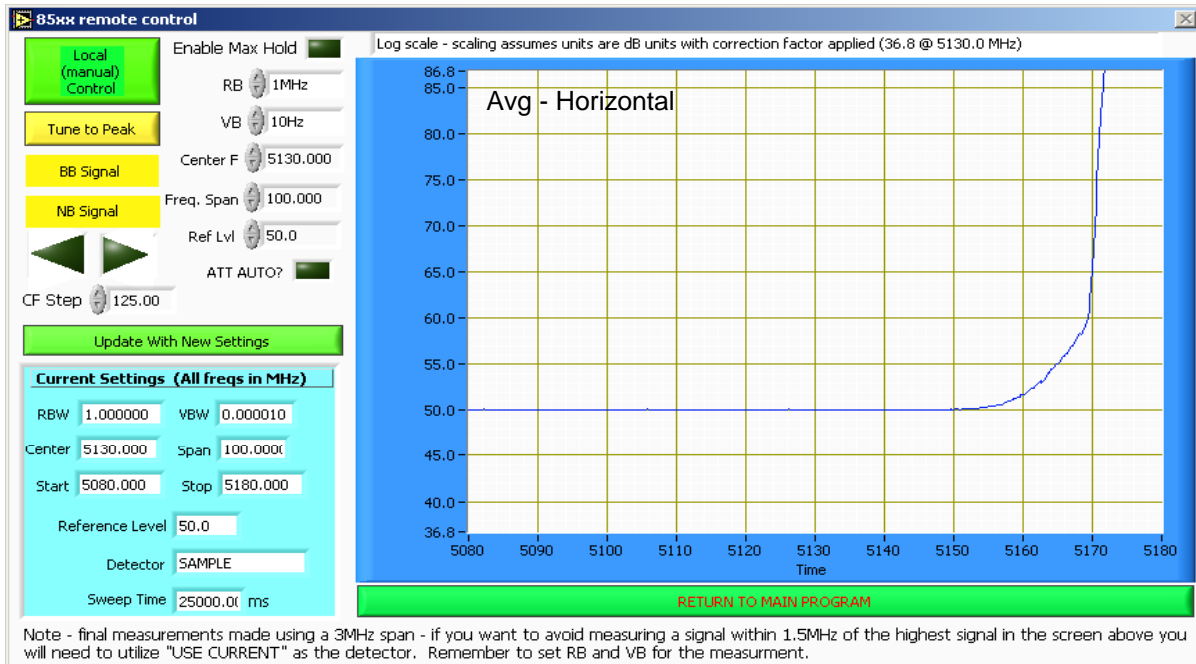

Note - final measurements made using a 3MHz span - if you want to avoid measuring a signal within 1.5MHz of the highest signal in the screen above you will need to utilize "USE CURRENT" as the detector. Remember to set RB and VB for the measurement.

Client: Xirrus	Job Number: J71456
Model: XN16 and XN8	T-Log Number: T71642
	Account Manager: Susan Pelzl
Contact: Steve Smith	
Standard: FCC 15.247 / RSS 210	Class: N/A

**RSS 210 and FCC 15.407 (UNII - 5150 - 5250 MHz)
Radiated Spurious Emissions, External Antenna**

Test Specific Details

Objective: The objective of this test session is to perform final qualification testing of the EUT with respect to the specification listed above.

Date of Test: 5/22/2008	Config. Used: 1
Test Engineer: Suhaila Khushzad	Config Change: None
Test Location: OATS #1	EUT Voltage: POE

General Test Configuration

The EUT and all local support equipment were located on the turntable for radiated spurious emissions testing. All remote support equipment was located approximately 30 meters from the EUT with all I/O connections running on top of the groundplane or rou

For radiated emissions testing the measurement antenna was located 3 meters from the EUT.

Ambient Conditions: Temperature: 20 °C
 Rel. Humidity: 45 %

Summary of Results

Run #	Mode	Channel	Power Setting	Radio	Test Performed	Limit	Result / Margin
1	802.11a	5180 MHz	17	4	Radiated Emissions, 1 - 40 GHz	FCC 15.209 / 15 E	39.9dBµV/m @ 15537.3MHz (-14.1dB)
	802.11a	5200 MHz		4			40.1dBµV/m @ 15601.8MHz (-13.9dB)
	802.11a	5240 MHz		4			40.8dBµV/m @ 15738MHz (-13.2dB)

Modifications Made During Testing

No modifications were made to the EUT during testing

Deviations From The Standard

No deviations were made from the requirements of the standard.

Client: Xirrus	Job Number: J71456
Model: XN16 and XN8	T-Log Number: T71642
	Account Manager: Susan Pelzl
Contact: Steve Smith	
Standard: FCC 15.247 / RSS 210	Class: N/A

Run #1, Radiated Spurious Emissions, 30 - 40,000 MH. Operation in the 5150-5250 MHz Band, 802.11a Mode, External Ant.
Run #1a: 5180 MHz, 802.11a, Low Channel, With External Antenna

Frequency Range	Test Distance	Limit Distance	Extrapolation Factor
1000 - 18000 MHz	3	3	0.0

Spurious Radiated Emissions:

Frequency MHz	Level dB μ V/m	Pol v/h	15.209 / 15E		Detector PK/QP/Avg	Azimuth degrees	Height meters	Comments
			Limit	Margin				
10352.420	39.9	V	68.3	-28.4	AVG	354	1.0	
10355.420	40.9	H	68.3	-27.4	AVG	45	1.0	
15537.250	39.9	H	54.0	-14.1	AVG	131	1.0	
15557.750	39.9	V	54.0	-14.1	AVG	317	1.0	
10352.420	51.1	V	88.3	-37.2	PK	354	1.0	
10355.420	53.1	H	88.3	-35.2	PK	45	1.0	
15537.250	51.7	H	74.0	-22.3	PK	131	1.0	
15557.750	51.4	V	74.0	-22.6	PK	317	1.0	

Run #1b: 5200 MHz, 802.11a, Center Channel, With External Antenna

Spurious Radiated Emissions:

Frequency MHz	Level dB μ V/m	Pol v/h	15.209 / 15E		Detector PK/QP/Avg	Azimuth degrees	Height meters	Comments
			Limit	Margin				
10390.750	39.5	H	68.3	-28.8	AVG	105	1.0	
10396.500	39.7	V	68.3	-28.6	AVG	325	1.1	
15601.750	40.1	V	54.0	-13.9	AVG	78	1.0	
15607.500	40.1	H	54.0	-13.9	AVG	346	1.0	
10390.750	52.0	H	88.3	-36.3	PK	105	1.0	
10396.500	51.3	V	88.3	-37.0	PK	325	1.1	
15601.750	51.5	V	74.0	-22.5	PK	78	1.0	
15607.500	51.2	H	74.0	-22.8	PK	346	1.0	

Run #1c: 5240 MHz, 802.11a, High Channel, With External Antenna

Spurious Radiated Emissions:

Frequency MHz	Level dB μ V/m	Pol v/h	15.209 / 15E		Detector PK/QP/Avg	Azimuth degrees	Height meters	Comments
			Limit	Margin				
10464.080	39.6	H	68.3	-28.7	AVG	346	1.0	
10464.420	39.5	V	68.3	-28.8	AVG	322	1.2	
15703.830	40.7	V	54.0	-13.3	AVG	360	1.0	
15738.000	40.8	H	54.0	-13.2	AVG	277	1.0	
10464.080	51.1	H	88.3	-37.2	PK	346	1.0	
10464.420	50.6	V	88.3	-37.7	PK	322	1.2	
15703.830	52.3	V	74.0	-21.7	PK	360	1.0	
15738.000	52.3	H	74.0	-21.7	PK	277	1.0	



Client: Xirus	Job Number: J71456
Model: XN16 and XN8	T-Log Number: T71642
	Account Manager: Susan Pelzl
Contact: Steve Smith	
Standard: FCC 15.247 / RSS 210	Class: N/A

RSS 210 and FCC 15.407 (UNII - 5150 - 5250 MHz) Radiated Spurious Emissions, Band Edges - Internal Antenna

Test Specific Details

Objective: The objective of this test session is to perform final qualification testing of the EUT with respect to the specification listed above.

Date of Test: 5/15/2008
 Test Engineer: Mehran Birgani
 Test Location: SVOATS #1

Config. Used: 1
 Config Change: None
 EUT Voltage: POE

General Test Configuration

The EUT and all local support equipment were located on the turntable for radiated spurious emissions testing. All remote support equipment was located approximately 30 meters from the EUT with all I/O connections running on top of the groundplane.

For radiated emissions testing the measurement antenna was located 3 meters from the EUT.

Ambient Conditions: Temperature: 35 °C
 Rel. Humidity: 20 %

Summary of Results

Run #	Mode	Channel	Power Setting	Test Performed	Limit	Result / Margin
1a	802.11a Chain A	5180 MHz	19.0	Restricted Band Edge at 5150 MHz	15.209	52.9dBµV/m (441.6µV/m) @ 5150.0MHz (-1.1dB)
1b	802.11a Chain A+C	5180 MHz	16.5	Restricted Band Edge at 5150 MHz	15.209	52.7dBµV/m (431.5µV/m) @ 5149.9MHz (-1.3dB)
1c	802.11n20 Chain A+C	5180 MHz	15.5	Restricted Band Edge at 5150 MHz	15.209	50.7dBµV/m (342.8µV/m) @ 5149.8MHz (-3.3dB)
1d	802.11n40 Chain A+C	5190 MHz	9.0	Restricted Band Edge at 5150 MHz	15.209	53.2dBµV/m (457.1µV/m) @ 5149.6MHz (-0.8dB)

Modifications Made During Testing

No modifications were made to the EUT during testing

Deviations From The Standard

No deviations were made from the requirements of the standard.

Client: Xirus	Job Number: J71456
Model: XN16 and XN8	T-Log Number: T71642
	Account Manager: Susan Pelzl
Contact: Steve Smith	
Standard: FCC 15.247 / RSS 210	Class: N/A

Run #1, Radiated Spurious Emissions, 30 - 40,000 MH. Operation in the 5150-5250 MHz Band

Run #1a: 5180 MHz, 802.11a, Chain A with power setting of 19.0 dBm.

5150 MHz Band Edge Signal Radiated Field Strength

Frequency MHz	Level dB μ V/m	Pol V/H	FCC 15.209		Detector PK/QP/Avg	Azimuth degrees	Height meters	Comments
			Limit	Margin				
5150.000	52.9	V	54.0	-1.1	AVG	11	2.5	RB 1.000 MHz; VB: 10 Hz
5150.000	42.0	H	54.0	-12.0	AVG	11	2.5	RB 1.000 MHz; VB: 10 Hz
5149.870	68.4	V	74.0	-5.6	PK	11	2.5	RB 1.000 MHz; VB: 1.000 MHz
5149.900	59.4	H	74.0	-14.6	PK	11	2.5	RB 1.000 MHz; VB: 1.000 MHz

Note 1: For emissions in restricted band immediately below 5150MHz, the limit of 15.209 was used.

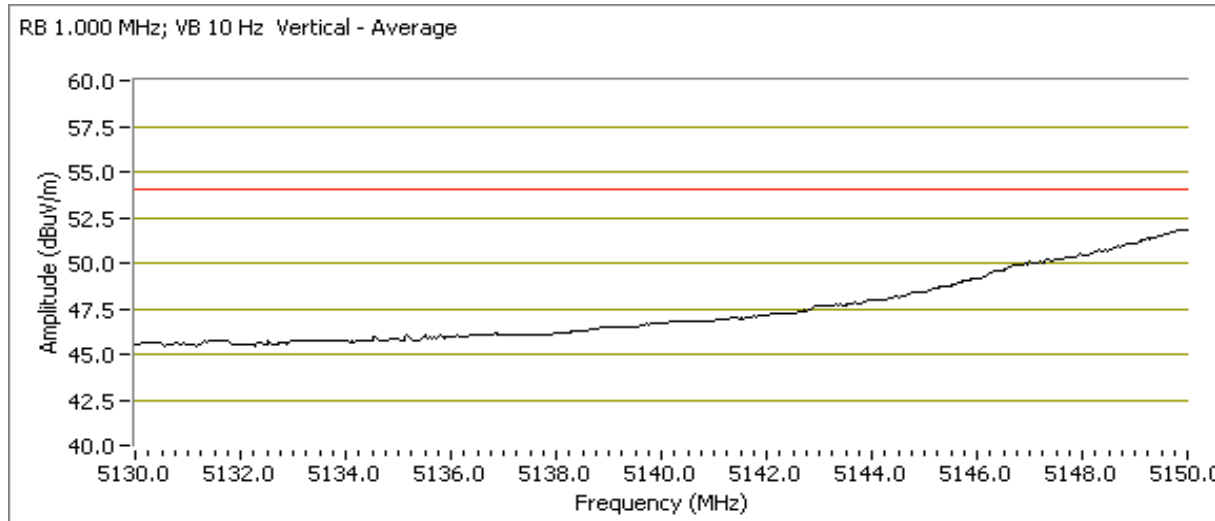
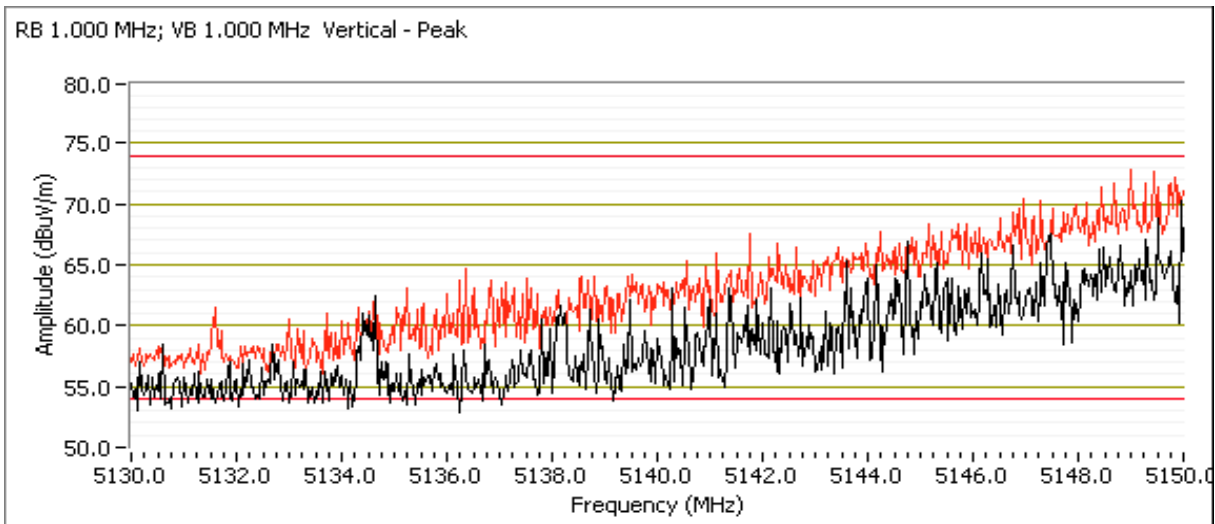

Client: Xirus	Job Number: J71456
Model: XN16 and XN8	T-Log Number: T71642
	Account Manager: Susan Pelzl
Contact: Steve Smith	
Standard: FCC 15.247 / RSS 210	Class: N/A

Run #1b: 5180 MHz, 802.11a, Chain A+C with power setting of 16.5dBm.

5150 MHz Band Edge Signal Radiated Field Strength

Frequency MHz	Level dB μ V/m	Pol V/H	FCC 15.209		Detector Pk/QP/Avg	Azimuth degrees	Height meters	Comments
			Limit	Margin				
5149.770	46.9	H	54.0	-7.1	AVG	8	2.0	RB 1.000 MHz; VB: 10 Hz
5149.930	52.7	V	54.0	-1.3	AVG	4	2.5	RB 1.000 MHz; VB: 10 Hz
5144.570	63.2	H	74.0	-10.8	PK	8	2.0	RB 1.000 MHz; VB: 1.000 MHz
5149.670	71.0	V	74.0	-3.0	PK	4	2.5	RB 1.000 MHz; VB: 1.000 MHz

Note 1: For emissions in restricted band immediately below 5150MHz, the limit of 15.209 was used.

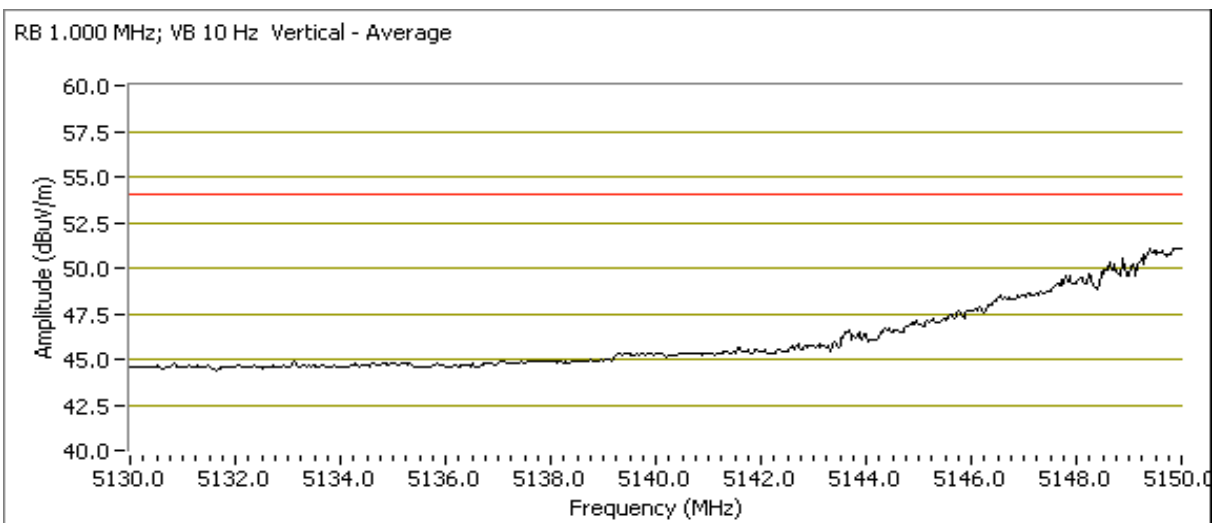
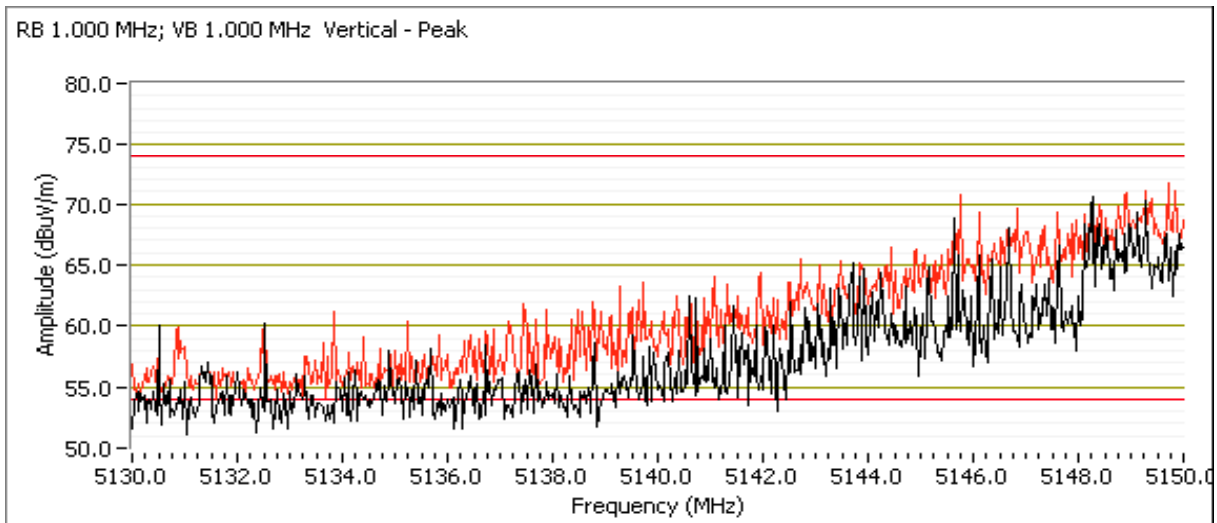

Client: Xirus	Job Number: J71456
Model: XN16 and XN8	T-Log Number: T71642
	Account Manager: Susan Pelzl
Contact: Steve Smith	
Standard: FCC 15.247 / RSS 210	Class: N/A

Run #1c: 5180 MHz, 802.11n 20MHz Chain A+C with power setting of 15.5dBm.

5150 MHz Band Edge Signal Radiated Field Strength

Frequency MHz	Level dB μ V/m	Pol V/H	FCC 15.209		Detector Pk/QP/Avg	Azimuth degrees	Height meters	Comments
			Limit	Margin				
5149.770	50.7	V	54.0	-3.3	AVG	7	2.5	00 MHz; VB: 10 Hz
5149.930	39.2	H	54.0	-14.8	AVG	0	2.0	00 MHz; VB: 10 Hz
5141.900	56.0	H	74.0	-18.0	PK	0	2.0	MHz; VB: 1.000 MHz
5146.430	70.5	V	74.0	-3.5	PK	7	2.5	MHz; VB: 1.000 MHz

Note 1: For emissions in restricted band immediately below 5150MHz, the limit of 15.209 was used.

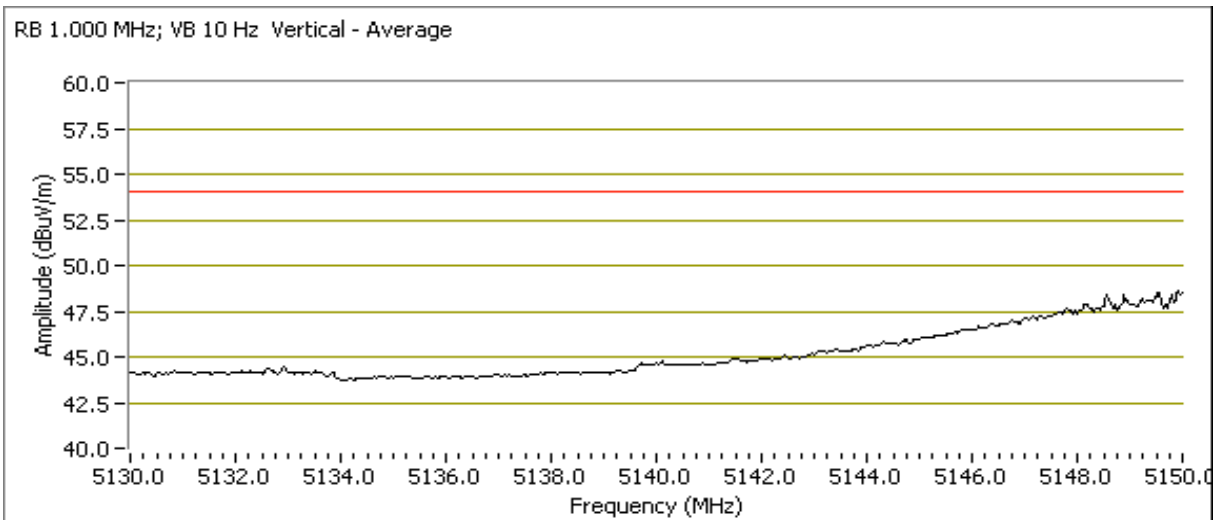
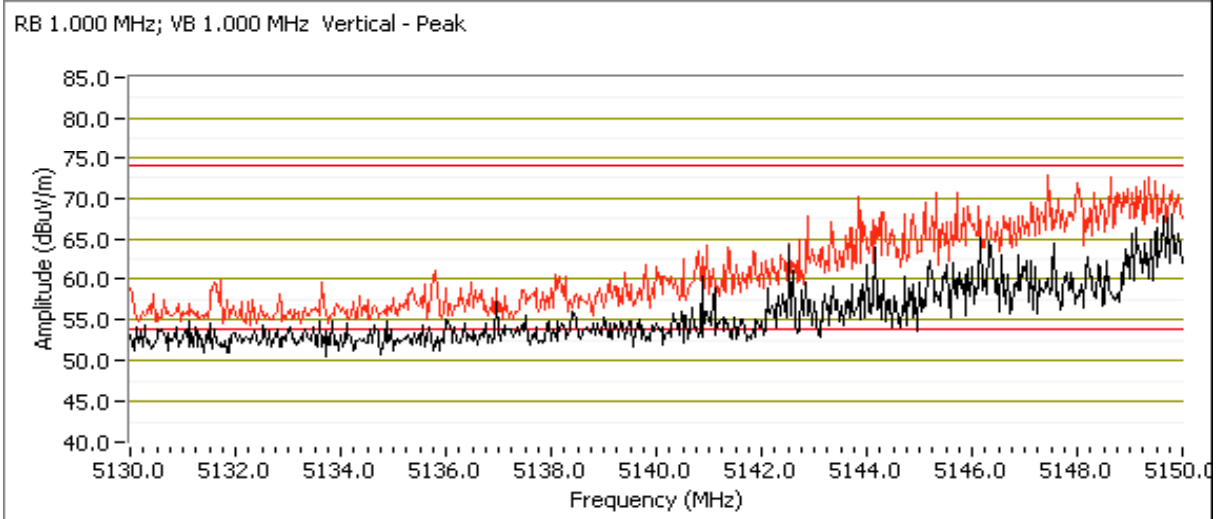

Client: Xirus	Job Number: J71456
Model: XN16 and XN8	T-Log Number: T71642
	Account Manager: Susan Pelzl
Contact: Steve Smith	
Standard: FCC 15.247 / RSS 210	Class: N/A

Run #1d: 5190 MHz, 802.11n 40MHz Chain A+C with power setting of 9.5dBm.

5150 MHz Band Edge Signal Radiated Field Strength

Frequency MHz	Level dB μ V/m	Pol V/H	FCC 15.209		Detector Pk/QP/Avg	Azimuth degrees	Height meters	Comments
			Limit	Margin				
5149.630	53.2	V	54.0	-0.8	AVG	360	2.5	RB 1.000 MHz; VB: 10 Hz
5150.000	41.4	H	54.0	-12.6	AVG	3	2.0	RB 1.000 MHz; VB: 10 Hz
5148.900	57.9	H	74.0	-16.1	PK	3	2.0	RB 1.000 MHz; VB: 1.000 MHz
5149.900	70.3	V	74.0	-3.7	PK	360	2.5	RB 1.000 MHz; VB: 1.000 MHz

Note 1: For emissions in restricted band immediately below 5150MHz, the limit of 15.209 was used.

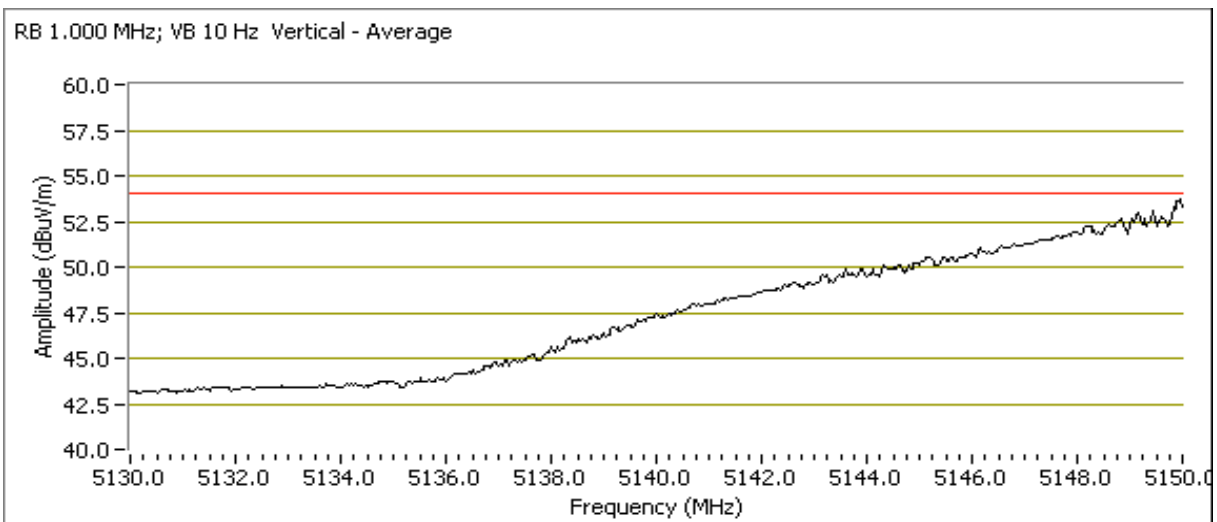
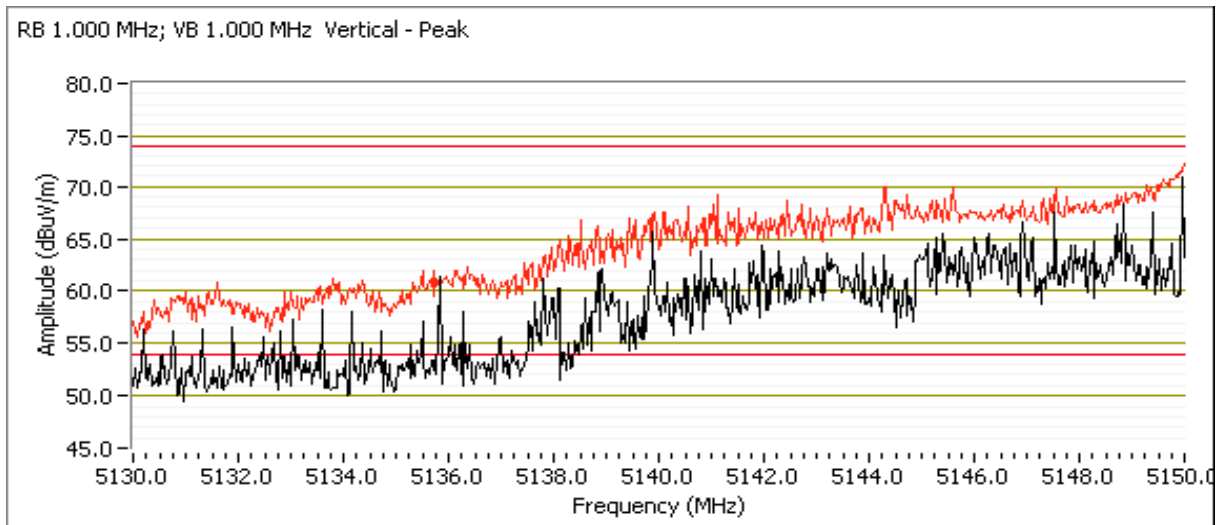

Client: Xirus	Job Number: J71456
Model: XN16 and XN8	T-Log Number: T71642
	Account Manager: Susan Pelzl
Contact: Steve Smith	
Standard: FCC 15.247 / RSS 210	Class: N/A

**RSS 210 and FCC 15.407 (UNII - 5150 - 5250 MHz)
Radiated Spurious Emissions, Internal Antenna**

Test Specific Details

Objective: The objective of this test session is to perform final qualification testing of the EUT with respect to the specification listed above.

Date of Test: 5/22/2008
 Test Engineer: Suhaila Khushzad
 Test Location: OATS #1

Config. Used: 1
 Config Change: None
 EUT Voltage: POE

General Test Configuration

The EUT and all local support equipment were located on the turntable for radiated spurious emissions testing. All remote support equipment was located approximately 30 meters from the EUT with all I/O connections running on top of the groundplane or rou

For radiated emissions testing the measurement antenna was located 3 meters from the EUT.

Ambient Conditions: Temperature: 20 °C
 Rel. Humidity: 45 %

Summary of Results

Run #	Mode	Channel	Power Setting	Measured Power	Test Performed	Limit	Result / Margin
1	802.11a, n20, n40	5180 MHz 5190 MHz	Refer to data		Radiated Emissions, 1 - 40 GHz	FCC 15.209 / 15 E	46.0dBµV/m @ 10356MHz (-22.3dB)
	802.11a, n20	5200 MHz					43.1dBµV/m @ 10396.0MHz (-25.2dB)
	802.11a, n20, n40	5240 MHz 5230 MHz					42.1dBµV/m @ 10484.8MHz (-26.2dB)

Modifications Made During Testing

No modifications were made to the EUT during testing

Deviations From The Standard

No deviations were made from the requirements of the standard.

Client: Xirrus	Job Number: J71456
Model: XN16 and XN8	T-Log Number: T71642
	Account Manager: Susan Pelzl
Contact: Steve Smith	
Standard: FCC 15.247 / RSS 210	Class: N/A

Run #1, Radiated Spurious Emissions, 30 - 40,000 MH. Operation in the 5150-5250 MHz Band, 802.11a Mode

Frequency Range	Test Distance	Limit Distance	Extrapolation Factor
1000 - 18000 MHz	3	3	0.0

Transmit mode, all radios at max power as follows: 5180 MHz 802.11a, 5200 MHz 802.11a, 5240 MHz 802.11a, 5180 MHz 802.11n20, 5200 MHz 802.11n20, 5240 MHz 802.11n20, 5190 MHz 802.11n40, 5230 MHz 802.11n40.

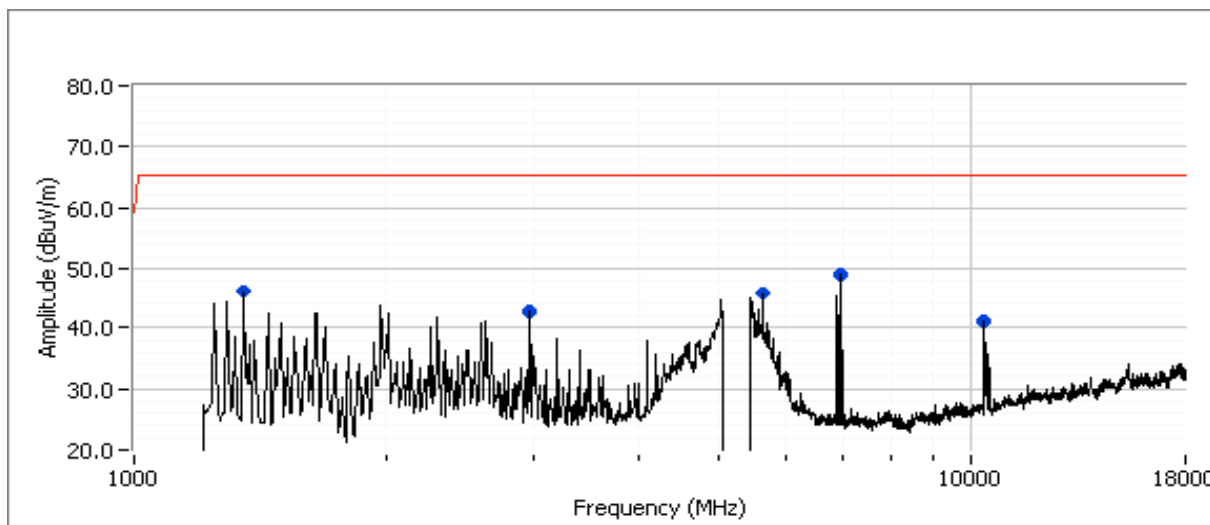

Scan made in anechoic chamber, measurements in tables below taken on OATS.

Client: Xirrus	Job Number: J71456
Model: XN16 and XN8	T-Log Number: T71642
	Account Manager: Susan Pelzl
Contact: Steve Smith	
Standard: FCC 15.247 / RSS 210	Class: N/A

Run #1a: 5180 MHz, 802.11a, 802.11n20 and 802.11n40 Low Channel

Radio	Channel (MHz)	Mode	Power Setting		Comments
			Chain A	Chain C	
1	5180	a	17	17	Power is the higher, single-chain power to cover MIMO & MISO modes
5	5180	n20	17	17	
9	5190	n40	17	17	

Spurious Radiated Emissions:

Frequency MHz	Level dB μ V/m	Pol v/h	15.209 / 15E		Detector Pk/QP/Avg	Azimuth degrees	Height meters	Comments
			Limit	Margin				
1369.4	24.3	H	54.0	-29.7	Average	0	2.0	
1381.4	25.1	V	54.0	-28.9	Average	21	1.0	
5657.2	33.6	H	68.3	-34.7	Average	218	1.0	Note 2
5731.0	33.9	V	68.3	-34.4	Average	190	1.0	Note 2
6972.4	35.2	V	68.3	-33.1	Average	100	1.0	Note 2
6978.4	35.3	H	68.3	-33.0	Average	237	1.0	Note 2 Check frequency
10356.0	46.0	V	68.3	-22.3	Average	248	2.1	Note 2
10358.1	42.4	H	68.3	-25.9	Average	142	1.5	Note 2 a/n20 second harmonic
10365.7	45.3	V	68.3	-23.0	Average	248	2.0	Note 2
10379.1	40.5	V	68.3	-27.8	Average	2	2.4	Note 2 n40 second harmonic
10387.8	41.1	H	68.3	-27.2	Average	213	1.5	Note 2 n40 second harmonic
1369.4	35.5	H	74.0	-38.5	Peak	0	2.0	
1381.4	36.5	V	74.0	-37.5	Peak	21	1.0	
5638.0	45.3	V	88.3	-43.0	Peak	190	1.0	Note 2
5657.2	44.9	H	88.3	-43.4	Peak	218	1.0	Note 2
6972.4	46.6	V	88.3	-41.7	Peak	100	1.0	Note 2
6978.4	46.8	H	88.3	-41.5	Peak	237	1.0	Note 2
10356.0	58.4	V	88.3	-29.9	Peak	248	2.1	Note 2
10358.1	52.9	H	88.3	-35.4	Peak	142	1.5	Note 2 a/n20 second harmonic
10365.7	57.5	V	88.3	-30.8	Peak	248	2.0	Note 2
10379.1	51.6	V	88.3	-36.7	Peak	2	2.4	Note 2 n40 second harmonic
10387.8	52.5	H	88.3	-35.8	Peak	213	1.5	Note 2 n40 second harmonic

Note 1: For emissions in restricted bands, the limit of 15.209 was used. For all other emissions outside the 5150 - 5250MHz band the **average** limit was set to -27dBm/MHz (-68.3 dBuV/m) and peak limit set to 20dB higher than the average limit (88.3 dBuV/m).

Note 2: Not in a restricted band

Client: Xirrus	Job Number: J71456
Model: XN16 and XN8	T-Log Number: T71642
	Account Manager: Susan Pelzl
Contact: Steve Smith	
Standard: FCC 15.247 / RSS 210	Class: N/A

Run #1b: 5200 MHz, 802.11a, 802.11n20 Center Channel

Radio	Channel (MHz)	Mode	Power Setting		Comments
			Chain A	Chain C	
2	5200	a	17	17	Power is the higher, single-chain power to cover MIMO & MISO modes
6	5200	n20	17	17	

Spurious Radiated Emissions:

Frequency MHz	Level dB μ V/m	Pol v/h	15.209 / 15E		Detector PK/QP/Avg	Azimuth degrees	Height meters	Comments
			Limit	Margin				
1369.4	24.3	H	54.0	-29.7	Average	0	2.0	
1381.4	25.1	V	54.0	-28.9	Average	21	1.0	
5657.2	33.6	H	68.3	-34.7	Average	218	1.0	Note 2
5731.0	33.9	V	68.3	-34.4	Average	190	1.0	Note 2
6972.4	35.2	V	68.3	-33.1	Average	100	1.0	Note 2
6978.4	35.3	H	68.3	-33.0	Average	237	1.0	Note 2
10396.0	43.1	V	68.3	-25.2	Average	178	1.5	Note 2
10400.8	43.0	H	68.3	-25.3	Average	175	1.9	Note 2
1369.4	35.5	H	74.0	-38.5	Peak	0	2.0	
1381.4	36.5	V	74.0	-37.5	Peak	21	1.0	
5638.0	45.3	V	88.3	-43.0	Peak	190	1.0	Note 2
5657.2	44.9	H	88.3	-43.4	Peak	218	1.0	Note 2
6972.4	46.6	V	88.3	-41.7	Peak	100	1.0	Note 2
6978.4	46.8	H	88.3	-41.5	Peak	237	1.0	Note 2
10396.0	54.3	V	88.3	-34.0	Peak	178	1.5	Note 2
10400.8	54.6	H	88.3	-33.7	Peak	175	1.9	Note 2

Note 1: For emissions in restricted bands, the limit of 15.209 was used. For all other emissions outside the 5150 - 5250MHz band the **average** limit was set to -27dBm/MHz (~68.3 dBuV/m) and peak limit set to 20dB higher than the average limit (88.3 dBuV/m).

Note 2: Not in a restricted band

Client: Xirrus	Job Number: J71456
Model: XN16 and XN8	T-Log Number: T71642
	Account Manager: Susan Pelzl
Contact: Steve Smith	
Standard: FCC 15.247 / RSS 210	Class: N/A

Run #1c: 802.11a, 802.11n20 and 802.11n40, High Channel

Radio	Channel (MHz)	Mode	Power Setting		Comments
			Chain A	Chain C	
4	5240	a	17	17	Power is the higher, single-chain power to cover MIMO & MISO modes
6	5240	n20	17	17	
12	5230	n40	17	17	

Spurious Radiated Emissions:

Frequency MHz	Level dBμV/m	Pol v/h	15.209 / 15E		Detector Pk/QP/Avg	Azimuth degrees	Height meters	Comments
			Limit	Margin				
1369.4	24.3	H	54.0	-29.7	Average	0	2.0	
1381.4	25.1	V	54.0	-28.9	Average	21	1.0	
5657.2	33.6	H	68.3	-34.7	Average	218	1.0	Note 2
5731.0	33.9	V	68.3	-34.4	Average	190	1.0	Note 2
6972.4	35.2	V	68.3	-33.1	Average	100	1.0	Note 2
6978.4	35.3	H	68.3	-33.0	Average	237	1.0	Note 2
10469.6	40.5	V	68.3	-27.8	Average	152	2.4	Note 2
10475.0	40.7	H	68.3	-27.6	Average	335	1.5	Note 2
10484.7	41.5	H	68.3	-26.8	Average	334	2.0	Note 2
10484.8	42.1	V	68.3	-26.2	Average	4	1.2	Note 2
1369.4	35.5	H	74.0	-38.5	Peak	0	2.0	
1381.4	36.5	V	74.0	-37.5	Peak	21	1.0	
5638.0	45.3	V	88.3	-43.0	Peak	190	1.0	Note 2
5657.2	44.9	H	88.3	-43.4	Peak	218	1.0	Note 2
6972.4	46.6	V	88.3	-41.7	Peak	100	1.0	Note 2
6978.4	46.8	H	88.3	-41.5	Peak	237	1.0	Note 2
10469.6	52.3	V	88.3	-36.0	Peak	152	2.4	Note 2
10475.0	51.8	H	88.3	-36.5	Peak	335	1.5	Note 2
10484.7	52.6	H	88.3	-35.7	Peak	334	2.0	Note 2
10484.8	53.5	V	88.3	-34.8	Peak	4	1.2	Note 2

Note 1: For emissions in restricted bands, the limit of 15.209 was used. For all other emissions outside the 5150 - 5250MHz band the **average** limit was set to -27dBm/MHz (~68.3 dBuV/m) and peak limit set to 20dB higher than the average limit (88.3 dBuV/m).

Note 2: Not in a restricted band



EMC Test Data

Client:	Xirrus	Job Number:	J71456
Model:	XN16 and XN8	T-Log Number:	T71645
		Account Manager:	Susan Pelzl
Contact:	Steve Smith		Mark Briggs
Emissions Standard(s):	FCC 15.109, RSS GEN, EN 55022, EN 301 489-17	Class:	B (A maybe OK)
Immunity Standard(s):	EN 301 489-1,-17 and EN 55024	Environment:	WLAN

AC Conducted Emissions Test Data

For The

Xirrus

Model

XN16 and XN8

Date of Last Test: 6/16/2008



EMC Test Data

Client:	Xirrus	Job Number:	J71456
Model:	XN16 and XN8	T-Log Number:	T71645
		Account Manger:	Susan Pelzl
Contact:	Steve Smith		
Emissions Standard(s):	FCC 15.109, RSS GEN, EN 55022, EN 301 489-17	Class:	B (A maybe OK)
Immunity Standard(s):	EN 301 489-1,-17 and EN 55024	Environment:	WLAN

EUT INFORMATION

General Description

The Xirrus, Inc. model XN16 is a multi-radio 802.11abgn Access Point radio which is designed to act as a hub for a wireless local area network (WLAN). There are two versions of the system, one (model XN16) contains 16 separate transceivers, the other (model XN8) contains 8 transceivers. The radio interfaces are provided via four identical circuit boards. Each of the boards has four 802.11abgn radios installed onto it (in the 8-port version two of these radios are removed from each board).

Normally, the EUT's would be ceiling mounted during operation. The EUT's were tested as both table-top equipment and also tested with the EUT raised to a height of 1.5m above the ground plane. The electrical rating of the device is 100/240Vac, 50/60Hz, 0.5-3A.

Equipment Under Test

Manufacturer	Model	Description	Serial Number	FCC ID
Xirrus	XN16	802.11abgn access point	Prototype	SK6XN16
Xirrus	XN8	802.11abgn access point	Prototype	SK6XN8

EUT Antenna

The antennas are either integral to the device or connect to the EUT via a non-standard, reverse gender TNC connector, thereby meeting the requirements of FCC 15.203.

EUT Enclosure

The EUT(XN16) enclosure is primarily constructed of plastic. It is circular with a diameter of 48 cm and a height of 10cm. The EUT(XN8) enclosure is primarily constructed of plastic. It is circular with a diameter of 48 cm and a height of 10cm. The antenna is integral to the device.



EMC Test Data

Client:	Xirrus	Job Number:	J71456
Model:	XN16 and XN8	T-Log Number:	T71645
		Account Manger:	Susan Pelzl
Contact:	Steve Smith		
Emissions Standard(s):	FCC 15.109, RSS GEN, EN 55022, EN 301 489-17	Class:	B (A maybe OK)
Immunity Standard(s):	EN 301 489-1,-17 and EN 55024	Environment:	WLAN

Modification History

Mod. #	Test	Date	Modification
1			
2			
3			

Modifications applied are assumed to be used on subsequent tests unless otherwise stated as a further modification.



EMC Test Data

Client:	Xirrus	Job Number:	J71456
Model:	XN16 and XN8	T-Log Number:	T71645
Contact:	Steve Smith	Account Manger:	Susan Pelzl
Emissions Standard(s):	FCC 15.109, RSS GEN, EN 55022, EN 301 489-17	Class:	B (A maybe OK)
Immunity Standard(s):	EN 301 489-1,-17 and EN 55024	Environment:	WLAN

Test Configuration #1 - XS16

Local Support Equipment

Manufacturer	Model	Description	Serial Number	FCC ID
Xirrus	PoE60U-560(G)-SS-R	Power Injector	P7450010A1	N/A

Remote Support Equipment

Manufacturer	Model	Description	Serial Number	FCC ID
IBM	R51	Laptop	99-V4543	DoC
Netgear	GS108	Switch	GS16152CB035447	DoC

Cabling and Ports

Port	Connected To	Cable(s)		
		Description	Shielded or Unshielded	Length(m)
PoE IN	Switch	Cat 5	Unshielded	10.0
PoE Out	Data& Power IN	Cat 5	Unshielded	1.0
Data (To GIG 1/2) OUT	Ethernet 1	Cat 5	Unshielded	0.1
AC Power	PoE	3 wire	Unshielded	1.5

Note 1: The console port on the XN-16 was not connected during testing. This port is used for configuration and troubleshooting purposes only and is not intended to be connected during normal operation.

Note 2: The gigabit ethernet# 2, ethernet# 0 ports on the XN16 were not connected during testing. These ports were not exercised for this configuration

EUT Operation During Emissions Tests

During AC conducted emissions and harmonics and Flicker testing all 16 (*8 for the XS-8*) radios were transmitting at max power on the following channels: 2412 MHz 802.11b, 2472 MHz 802.11g, 2437MHz 802.11n20, 5180 MHz 802.11a, 5320 MHz 802.11n20, 5500 MHz 802.11n40, 5700 MHz 802.11a, 5825 MHz 802.11n20, 5745 MHz 802.11n 20, 5600 MHz n20, 2412 MHz 802.11n20, 2462 MHz 802.11n20, 5510MHz n40, 5690 MHz 802.11n40, 5240 MHz 802.11a, 5260 MHz 802.11a, 5280 MHz 802.11n20

During radiated emissions tests all 16 radios (*8 for the XS-8*) were in receive mode with all chains active on the following channels: 2437 MHz, 5200 MHz, 5280 MHz, 5600 MHz, 5785 MHz, 2412 MHz, 2472 MHz, 5180 MHz, 5320 MHz, 5500 MHz, 5700 MHz, 5785 MHz, 2462 MHz, 5240MHz,5260 MHz, 5540 MHz. Transmit mode emissions are covered by the relevant radio standards.

The ethernet interface was active for all tests and exercised via **??fast pings??** from the laptop PC connected to the ethernet port.

Client: Xirrus	Job Number: J71456
Model: XN16 and XN8	T-Log Number: T71645
	Account Manager: Susan Pelzl
Contact: Steve Smith	
Standard: FCC 15.109, RSS GEN, EN 55022, EN 301 489-17	Class: B (A maybe OK)

Conducted Emissions - Power Ports

Test Specific Details

Objective: The objective of this test session is to perform final qualification testing of the EUT with respect to the specification listed above.

Date of Test: 6/3/2008
 Test Engineer: Chris Groat
 Test Location: SVOATS #1

Config. Used: 1
 Config Change: none
 EUT Voltage: 230V/50Hz & 120V/60Hz

General Test Configuration

The EUT was located on a wooden table, 40 cm from a vertical coupling plane and 80cm from the LISN. A second LISN was used for all local support equipment. Remote support equipment was located approximately 30 meters from the test area. All I/O connections were routed overhead.

Ambient Conditions: Temperature: 23 °C
 Rel. Humidity: 43 %

Summary of Results

Run #	Test Performed	Limit	Result	Margin
1	CE, AC Power, 230V/50Hz Model XN16	EN 55022 Class B	Pass	41.3dBµV @ 0.469MHz (-5.2dB)
2	CE, AC Power, 120V/60Hz Model XN16	FCC 15.109 Class B FCC 15.209 RSS GEN	Pass	42.8dBµV @ 4.670MHz (-3.2dB)
3	CE, AC Power, 230V/50Hz Model XN8	EN 55022 Class B		Covered by XN16 as worst case
4	CE, AC Power, 120V/60Hz Model XN8	FCC 15.109 Class B FCC 15.209 RSS GEN		Covered by XN16 as worst case

Modifications Made During Testing

No modifications were made to the EUT during testing

Deviations From The Standard

No deviations were made from the requirements of the standard.

Client: Xirus	Job Number: J71456
Model: XN16 and XN8	T-Log Number: T71645
	Account Manager: Susan Pelzl
Contact: Steve Smith	
Standard: FCC 15.109, RSS GEN, EN 55022, EN 301 489-17	Class: B (A maybe OK)

Run #1: AC Power Port Conducted Emissions, 0.15 - 30MHz, 230V/50Hz MODEL XN16

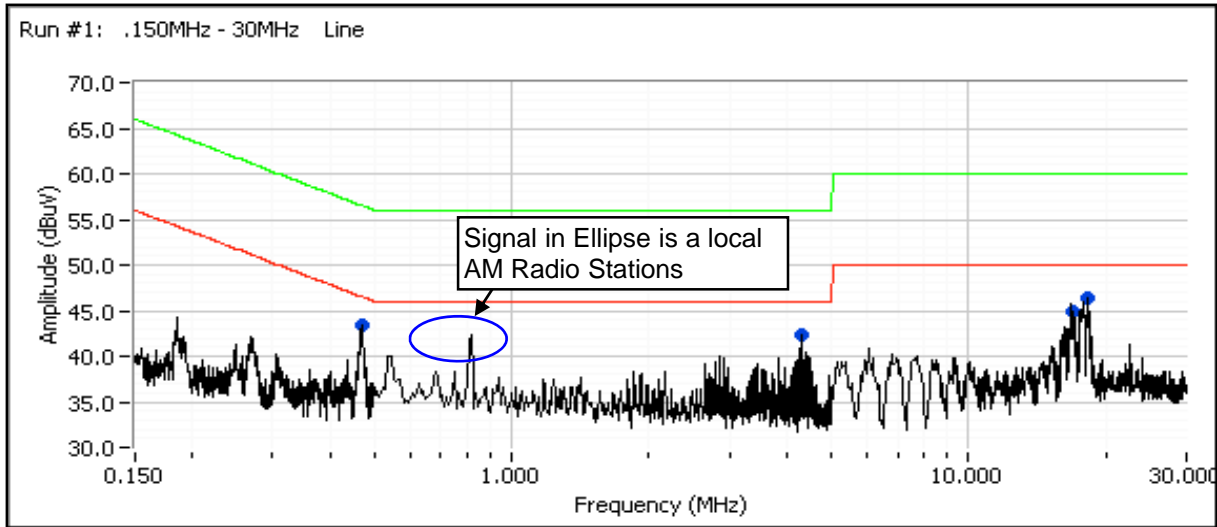
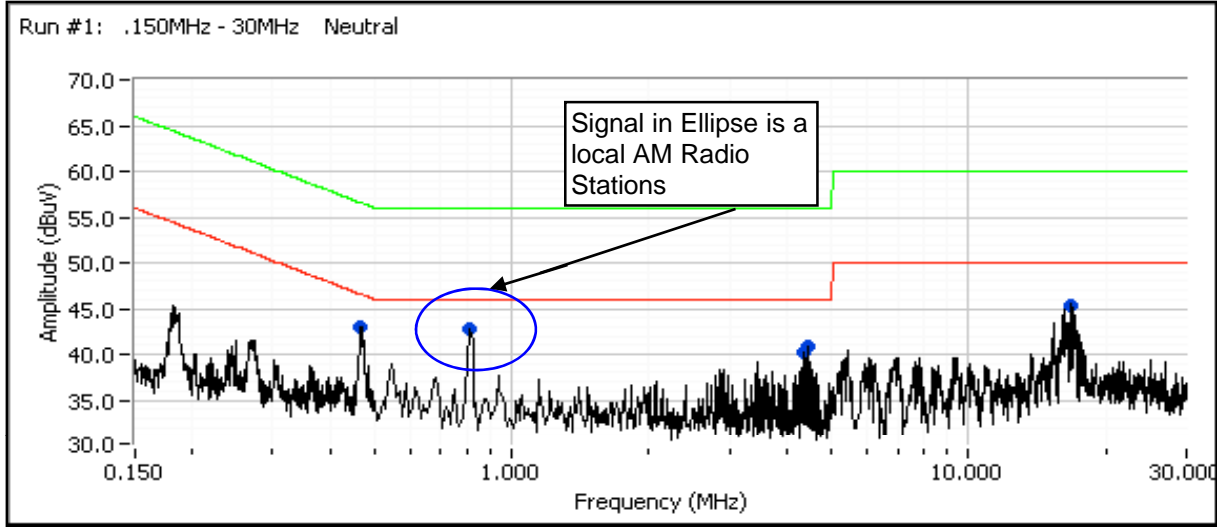



EMC Test Data

Client: Xirrus	Job Number: J71456
Model: XN16 and XN8	T-Log Number: T71645
	Account Manager: Susan Pelzl
Contact: Steve Smith	
Standard: FCC 15.109, RSS GEN, EN 55022, EN 301 489-17	Class: B (A maybe OK)

Run #1: AC Power Port Conducted Emissions, 0.15 - 30MHz, 230V/50Hz MODEL XN16

Frequency MHz	Level dB μ V	AC Line	EN55022 B		Detector QP/Ave	Comments
			Limit	Margin		
0.469	41.3	Line 1	46.5	-5.2	AVG	
0.468	41.1	Neutral	46.5	-5.4	AVG	
4.460	38.7	Neutral	46.0	-7.3	AVG	
4.399	38.6	Neutral	46.0	-7.4	AVG	
16.893	38.5	Neutral	50.0	-11.5	AVG	
4.347	33.0	Line 1	46.0	-13.0	AVG	
16.909	35.6	Line 1	50.0	-14.4	AVG	
0.468	40.8	Neutral	56.5	-15.7	QP	
0.469	40.8	Line 1	56.5	-15.7	QP	
4.460	38.5	Neutral	56.0	-17.5	QP	
4.399	38.3	Neutral	56.0	-17.7	QP	
16.893	41.9	Neutral	60.0	-18.1	QP	
18.275	30.9	Line 1	50.0	-19.1	AVG	
16.909	40.7	Line 1	60.0	-19.3	QP	
4.347	33.3	Line 1	56.0	-22.7	QP	
18.275	36.9	Line 1	60.0	-23.1	QP	

Client: Xirrus	Job Number: J71456
Model: XN16 and XN8	T-Log Number: T71645
	Account Manager: Susan Pelzl
Contact: Steve Smith	
Standard: FCC 15.109, RSS GEN, EN 55022, EN 301 489-17	Class: B (A maybe OK)

Run #2: AC Power Port Conducted Emissions, 0.15 - 30MHz, 120V/60Hz MODEL XN16

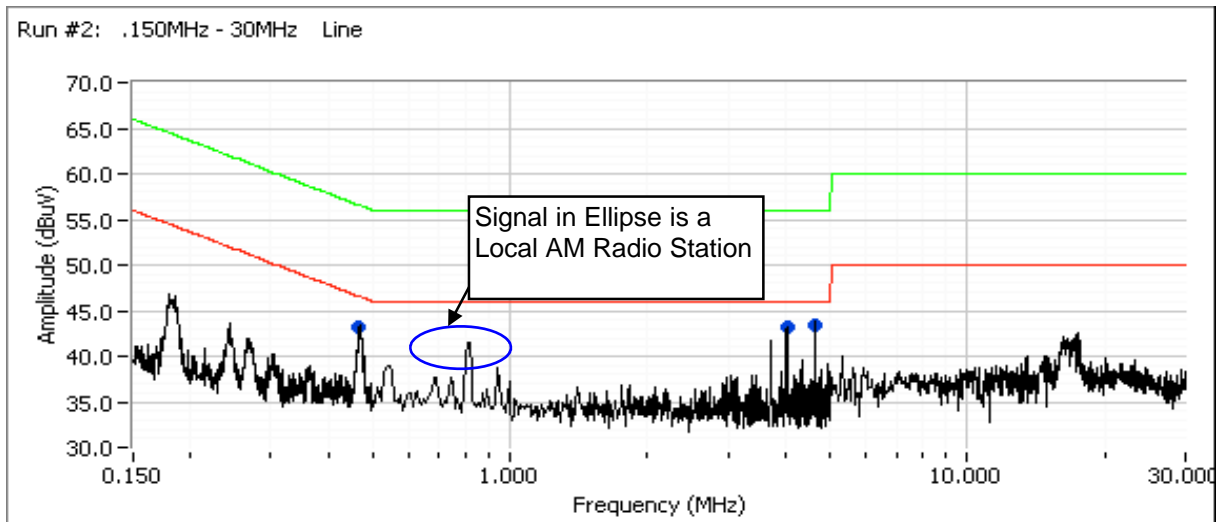
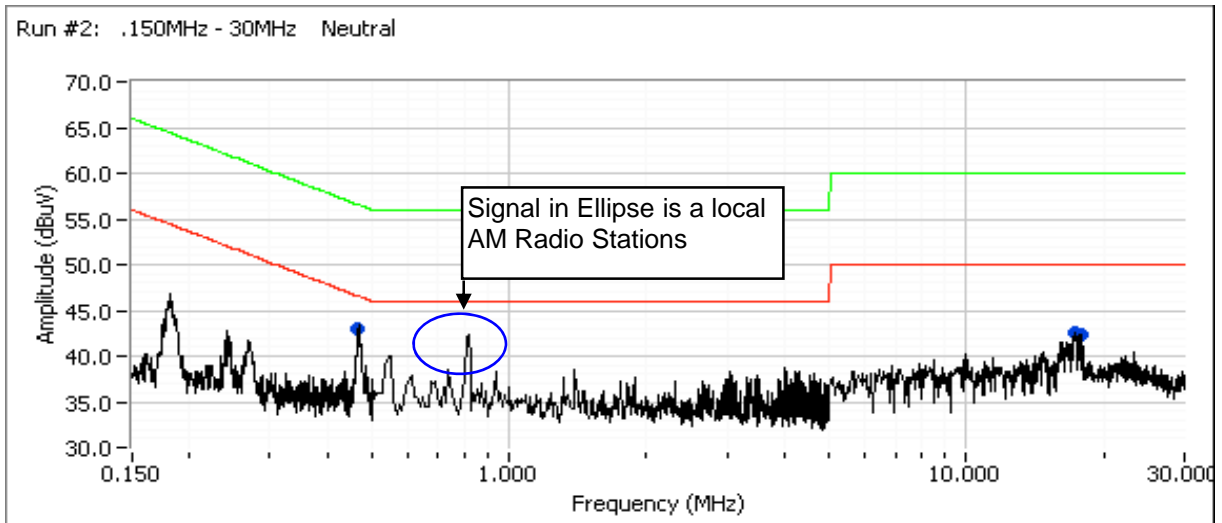



EMC Test Data

Client: Xirrus	Job Number: J71456
Model: XN16 and XN8	T-Log Number: T71645
	Account Manager: Susan Pelzl
Contact: Steve Smith	
Standard: FCC 15.109, RSS GEN, EN 55022, EN 301 489-17	Class: B (A maybe OK)

Run #2: AC Power Port Conducted Emissions, 0.15 - 30MHz, 120V/60Hz MODEL XN16

Frequency MHz	Level dB μ V	AC Line	EN55022 B		Detector QP/Ave	Comments
			Limit	Margin		
4.670	42.8	Line 1	46.0	-3.2	AVG	
0.469	41.4	Line 1	46.5	-5.1	AVG	
0.469	41.2	Neutral	46.5	-5.3	AVG	
4.047	40.3	Line 1	46.0	-5.7	AVG	
4.670	45.3	Line 1	56.0	-10.7	QP	
17.316	38.3	Neutral	50.0	-11.7	AVG	
4.047	42.8	Line 1	56.0	-13.2	QP	
17.676	35.7	Neutral	50.0	-14.3	AVG	
0.469	41.0	Line 1	56.5	-15.5	QP	
0.469	40.9	Neutral	56.5	-15.6	QP	
17.316	41.4	Neutral	60.0	-18.6	QP	
17.676	39.6	Neutral	60.0	-20.4	QP	

EXHIBIT 3: Photographs of Test Configurations

2 Pages