

**NOTES:**

1 INSTALL ITEM #2 (PRODUCT LABEL) AS INDICATED. ENSURE THE LABEL IS FULLY ADHERED TO THE POWER COAT FINISH.

2 INSTALL ITEMS #3 AND #4 (LABELS) AS INDICATED.

REVISIONS				
ZONE	REV.	DESCRIPTION	DATE	APPROVED
	1	INITIAL RELEASE	7/18/2013	I. LAITY
	2	ADDED SECONDARY LABELS / MOUNTING BRACKET	9/19/2013	I. LAITY
	A	PRODUCTION RELEASE	10/28/2013	I. LAITY

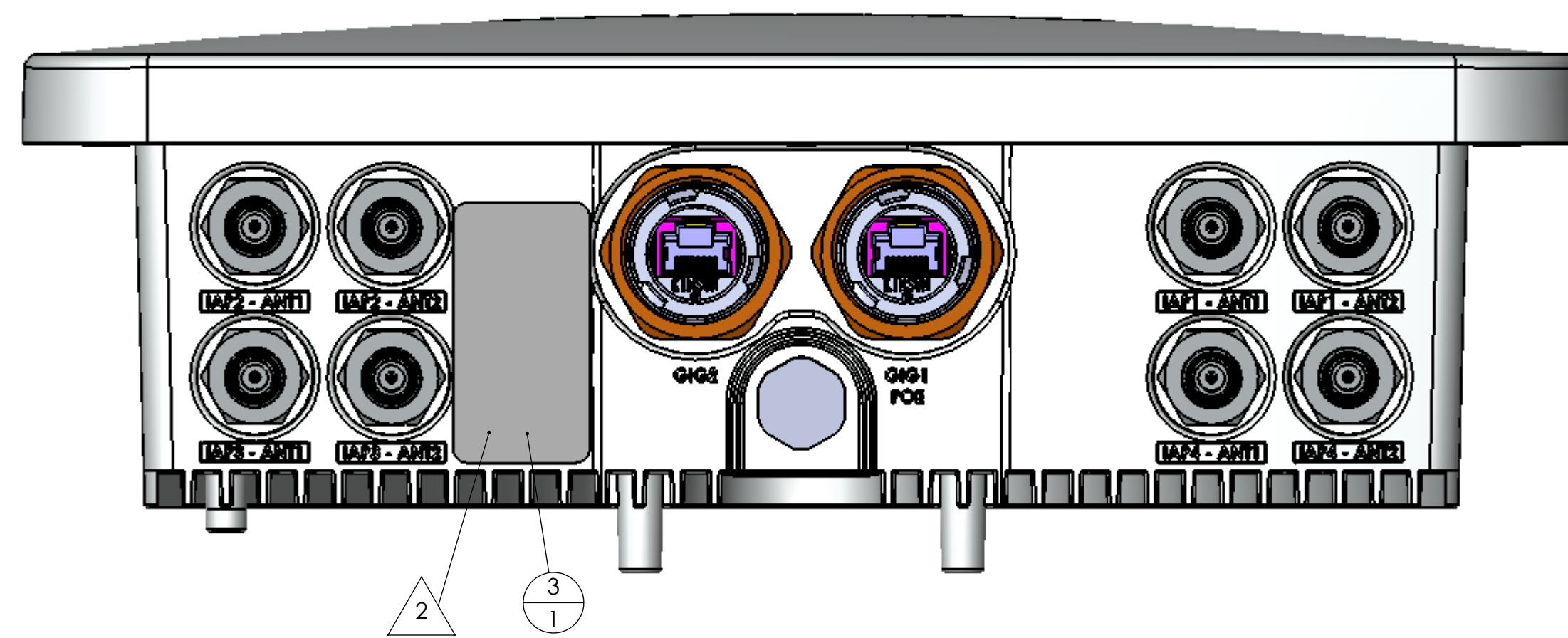
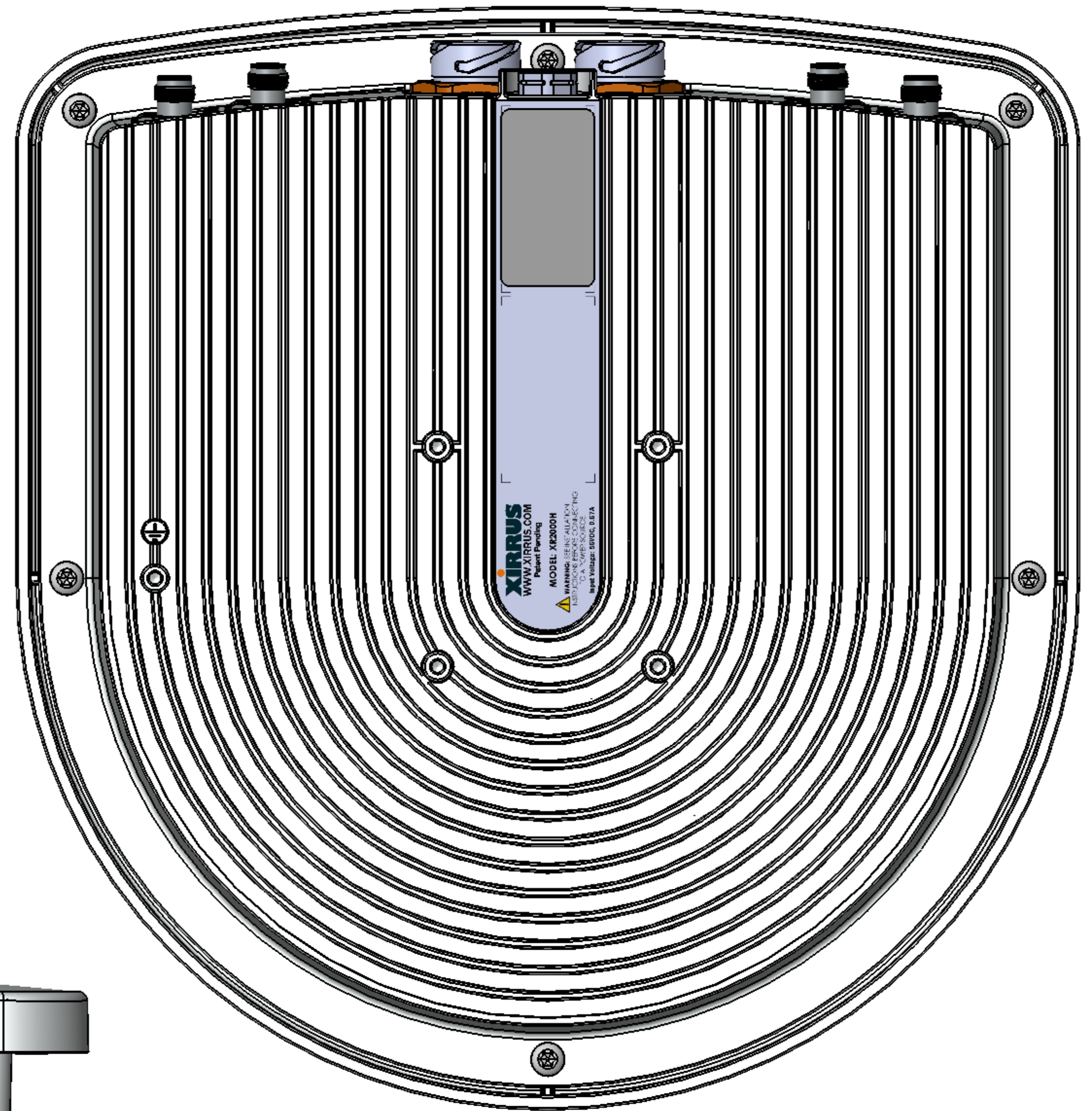
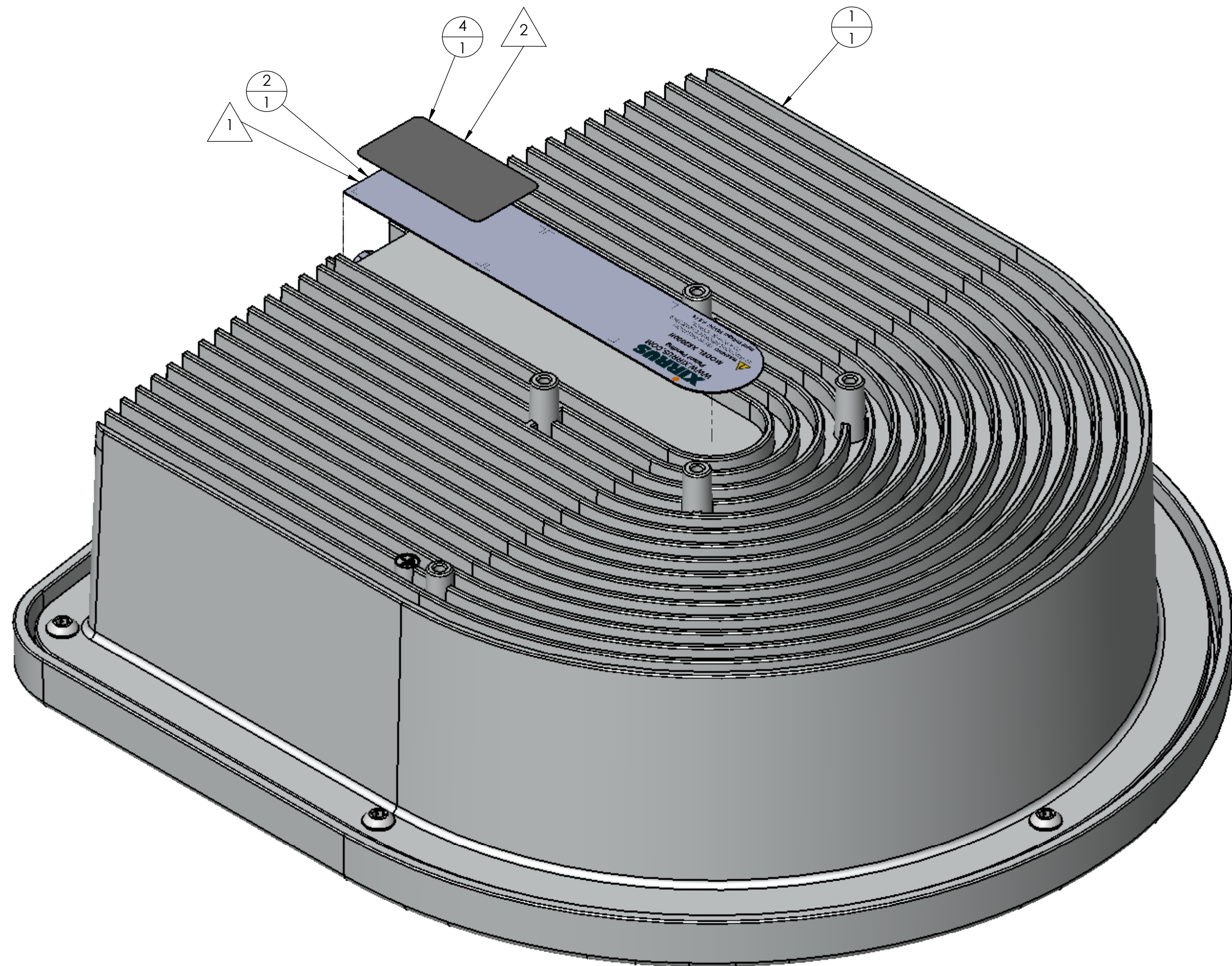

ITEM NO.	PartNo	DESCRIPTION	Phase 2/QTY.
1	170-0103-001	TLA, XR-2425H, QUAD 2X2 IAP	1
2	830-0378-001	LABEL, XR-2425H	1
3	830-0322-001	LABEL, PRODUCT, TLA, XR-1000/XR-2000/XR-4000, POST PRINTED	1
4	830-0380-001	LABEL, PRODUCT APPROVALS, XR-2425H, POST PRINTED	1

UNLESS OTHERWISE SPECIFIED:  
 DIMENSIONS - INCHES / MM  
 TOLERANCES:  
 FRACTIONAL ± 1/16"  
 ANGULAR: MACH ± 1/4"  
 BEND ± 1/4"  
 XX ± .01 IN. ± .3 MM  
 XXX ± .005 IN. ± .13 MM  
 INTERPRET GEOMETRIC TOLERANCING PER ASME Y14.5M MATERIAL FINISH DO NOT SCALE DRAWING

PROPRIETARY AND CONFIDENTIAL  
 THE INFORMATION CONTAINED IN THIS DRAWING IS THE SOLE PROPERTY OF XIRRUS. ANY REPRODUCTION IN PART OR AS A WHOLE WITHOUT THE WRITTEN PERMISSION OF XIRRUS IS PROHIBITED.

NAME	DATE
I. LAITY	7/18/2013
I. LAITY	7/18/2013

**XIRRUS** 2101 CORPORATE CENTER DRIVE, THOUSAND OAKS, CA 91320  
 TITLE: TLA, LABELED, XR-2425H, QUAD 2X2 IAP  
 SIZE DWG. NO. REV  
**D** 185-0095-001 **A**  
 PART NO. 180-0095-001  
 SCALE 1:2 SHEET 1 OF 1