



Hardened Wireless Access Point XH2-120 Quick Installation Guide

September 16, 2015

 is a registered trademark of Xirrus, Inc. All other trademarks and brand names are marks of their respective holders.

Please see Legal Notices, Warnings, Compliance Statements, and Warranty and License Agreements in the *Wireless AP User's Guide*.

All rights reserved. This document may not be reproduced or disclosed in whole or in part by any means without the written consent of Xirrus, Inc.

Part Number: 812-0085-011 Rev A September 16, 2015

Quick Installation Guide

For XH2 Models

The XH2 Series Hardened Wireless Access Point provides two dual-band 802.11ac radios in a hardened case for installation outdoors and in other harsh environments. This guide describes how to install the XH2 Series on a pole or wall and execute the initial power up of the AP. The pole or wall can be a structure that is at ground level or on a roof. The XH2 is not compatible with other Xirrus mounting options. For additional information, see the *Wireless AP User's Guide*.



The XH2 Series includes the XH2-120 (Model XH2120). This document is intended ONLY for XH2 model APs. For other models please see the installation guide for that model series.

1

You Need the Following Items

- ◆ Professional Installation Required—regulatory requirements for the XH2-120 mandate that the device be installed and configured for use by trained professionals only. Direct questions regarding installation and use of the products to Xirrus Customer Support (see last page).
- ◆ Accessory Kit (included in each AP carton) includes:
 - ◆ Mounting bracket and eight attachment screws
 - ◆ Grounding screw
 - ◆ Two watertight RJ connector assemblies
- ◆ Appropriate tools, bands, screws, and/or anchors required for the desired mounting location (not provided with the AP).
- ◆ Antennas and cables for two radios, to be installed by a professional installer. Cables are low-loss outdoor-rated coaxial cables terminated with N-type male connectors (e.g., Xirrus part number ANT-CAB-195-10-MM-02). Note that some antennas include integrated cables as part of the unit, and these do not need separate cables.

See *Xirrus External Antenna Guide* for recommended antennas. If you are not using one of the recommended antennas, the XH2-120's output power setting must be reduced by 1 dB for every dB above 6dBi gain the selected antenna may produce.

- ◆ Grounding wire and lug. If lightning surges are a concern, consider using a lightning arrester.
- ◆ Workstation with a Web browser to configure the AP.
- ◆ RJ-45 Ethernet connection(s) to your wired network.
- ◆ **Gigabit1/PoE+** —XH2-120 APs are powered via one Power over Ethernet (PoE) port using an outdoor-rated Ethernet Cat 5e or Cat 6 cable that also carries data traffic. Use only 802.3at

PoE+ compliant switches or power injectors, or a Xirrus-supplied PoE injector (the 30W XP1-MSI-30, or current models rated at 70W or higher).

- ◆ (Optional) **GIGABIT2**—Connection to this second, data-only Gigabit port provides additional bandwidth. Use Cat 5E or Cat 6 cable.
- ◆ The AP protects its inputs from typical static charge buildup on antennas. In areas where lightning surges are a concern, a lightning arrestor may be used between the antenna and the AP, with 6 AWG copper wire from the arrestor to a good earth ground.

NOTE: PoE Injectors and switches must be installed and used indoors.

NOTE: If XH2 models are used indoors, they are to be connected only to PoE networks without routing to the outside plant.

NOTE: The AP comes with plastic covers installed on Ethernet and antenna ports. You MUST leave these covers securely installed on unused ports to prevent weather damage.

2

Choose a Suitable Location

The XH2-120 is tested to IP65 waterproof and dust-proof requirements to protect against severely wet and dusty environments. For optimal placement, we recommend that a predictive survey be performed by a qualified Xirrus partner.

- ◆ Choose a location that is not subjected to submersion.
- ◆ Direct sunlight may raise the effective ambient temperature many degrees above air temperature. It is best to choose a location that has some protection from the sun.
- ◆ The maximum cable length between the XH2-120 and the RJ-45 Ethernet network is 100 meters. The PoE injector is not a repeater, so its location will not increase this distance.
- ◆ The XH2-120 can operate from a Wireless Distribution System (WDS) link. However, the unit will need to be configured via the Ethernet connection prior to mounting and power must still be supplied via the GIG1 Ethernet connector.
- ◆ Keep the unit away from electrical devices or appliances that generate RF noise—at least 3 to 6 feet (1 to 2 meters).
- ◆ The AP must be installed in a position so that the LED's cover is not directly affected by the Sun's radiation (typically with the LED and Ethernet connectors facing down).

3

Prepare the Mounting Location

The installation must ensure that the AP is grounded to earth ground to dissipate any static electric charge that may develop due to wind.

XH Outdoor Access Points

- ◆ Determine a good electrical earth ground point near the AP mounting location. If an earth ground point is not available, consult an electrician to have one installed.
- ◆ Before the AP is attached to a wall or pole, secure a grounding wire and lug to the AP with the provided screw in the location indicated in the illustration.

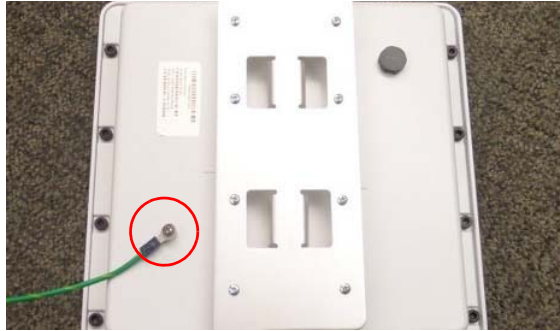

4

Attach the Mounting Plate to the AP

The accessory kit includes a mounting plate. Mounting plate dimensions are included in “Physical/Environmental Specifications” on page 12. The mounting plate can be used for wall or pole mounting by reversing the side of the plate exposed. Attach the mounting plate to the AP using the eight provided screws in the locations indicated below (secure in at least 4 places).

For Wall Mounting:

For Wall Mounting, position the bracket with the four slotted flanges pointed towards the AP, as shown in Step 3, above.

For Pole Mounting:

For Pole Mounting, position the bracket with the four slotted flanges pointed away from the AP, as shown below.

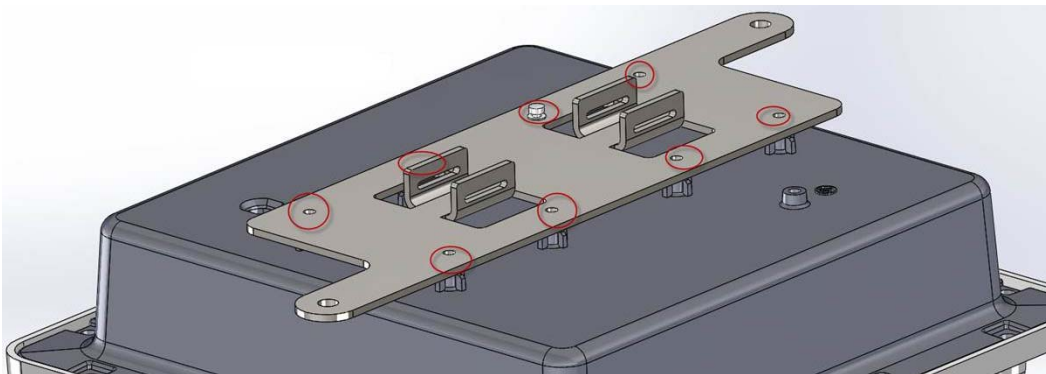

5

Mount the AP on a Pole or Wall

5a—Pole Mounting

For pole mounting, Xirrus recommends using metal straps (not included with the AP). The metal straps can be obtained from BAND-IT-IDEX, Inc. (www.BAND-IT-IDEX.com). See their web site for additional contact information. Complete the following steps to mount the AP to a pole.

- ◆ Install the metal bands through the holes in the mounting bracket.
- ◆ Note that the photos below show a different mounting bracket. The steps for installation are identical, however.
- ◆ Hand tighten the Band-It strap through the pole mounting bracket, thread it through the strap buckle and then bend the strap back.
- ◆ Using the Band-It tool, place the tool onto the strap.
- ◆ Rotate the Band-It tool so that it can pull the excess strap through the buckle and turn the crank until the strap is very tight.

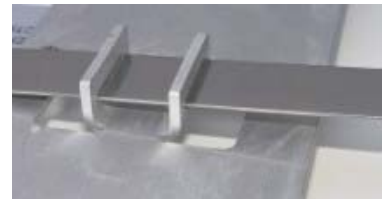

XH Outdoor Access Points

- ◆ Once the strap is satisfactorily tight, rotate the Band-It tool back so that the strap cannot slide back through the buckle.
- ◆ Using the built in cutting tool on the Band-It tool, cut the excess strap.
- ◆ Your installation should now appear as shown here.
- ◆ Using a hammer, bend back and flatten the remaining strap.
- ◆ Using a hammer, bend and flatten the two tabs on the buckle to hold the flattened strap end in place.
- ◆ The completed attachment should have the mounting bracket firmly seated against the pole. One band should be enough for most installations however a second band can be used for additional mounting security.

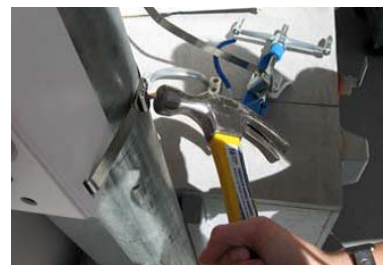

5b—Wall Mounting

- ◆ Place the AP in the desired location and mark the location of the two mounting holes on the wall, as shown.
- ◆ Drill and prepare the holes for the desired screw type. In metal walls the holes may be tapped to the proper thread or the AP may be mounted with sheet metal screws. For concrete walls, a plastic anchor and screw are suggested.

NOTE: Mounting screws for attaching the plate to the wall are not provided in the kit.

- ◆ The AP should already be secured to the mounting plate (Step 4). Mount the assembly to the wall, securing it at the two locations indicated.

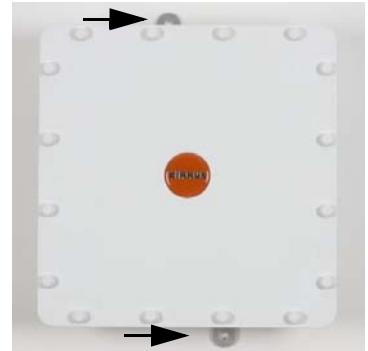

6

Ground to Earth Ground

WARNING: This equipment must be externally grounded using a customer-supplied ground wire before power is applied. Contact the appropriate electrical inspection authority or an electrician if you are uncertain that suitable grounding is available.

The mechanical installation must ensure that the AP is grounded to earth ground to dissipate static electric charge that may develop due to wind. In Step 3, you secured a grounding wire to the AP.



- ◆ After Step 3 is complete and the AP is mounted to the wall or pole, attach the grounding wire from the AP to the electrical earth ground point that you located or installed in Step 3. The photo shows an earth ground connection where the AP is mounted on a pole at ground level and the grounding wire is attached to a stake driven into the ground.
- ◆ Continue the installation by mounting the antenna and attaching the cables as described in Steps 7, 8, and 9.

7

Install Antenna(s)

See the *Xirrus External Antenna Guide* for recommended antennas.

NOTE: See the Warnings and Notices regarding external antennas in “Notices, Warnings & Compliance Statements” on page 13.

NOTE: Be sure to configure the AP’s IAPs to the proper bands (2.4 GHz and 5.0 GHz) in Step 10. Each must match the band of the antenna to which it is connected.

- ◆ Install your antenna(s) as directed by the manufacturer.
- ◆ Use low-loss outdoor-rated coaxial cables terminated with male N type connectors (e.g., Xirrus part number ANT-CAB-195-10-MM-2). Note that some antennas include integrated cables as part of the unit, and these do not need separate cables.

8

Connect the Ethernet Cable with the Waterproof Connector

- ◆ **Power:** These APs are only powered through the GIG1 PoE+ port.
- ◆ **Data:** Data is supplied to the GIG1-POE+ port via the same cable that powers the AP, and a second optional connection to the GIG2 port.

NOTE: It is VERY IMPORTANT to assemble the waterproof connector properly, following the directions below. Failure to do so may expose the AP to the elements, and may result in an intermittent connection causing the AP to connect at very low speeds! If you are not using GIG2, you MUST leave its plastic protector cap securely installed.

- ◆ The Ethernet cable must be terminated with a simple RJ45 plug with the tab exposed, as shown on the left below. Do not use a plug with a tab protector boot, as shown on the right. This will not seat properly in the waterproof connector, and the assembly will not be watertight.

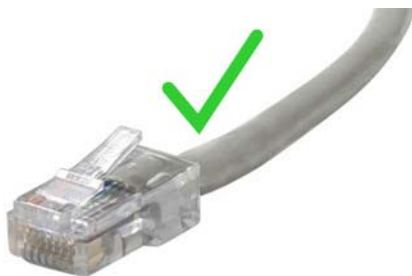

XH Outdoor Access Points

- ◆ Assemble the PoE connector. The components of the connector are shown in the photo below in the order that they are placed onto the Ethernet cable, and also shown in more detail as a color-coded drawing. You will perform a few assembly steps below before sliding the parts onto the cable.

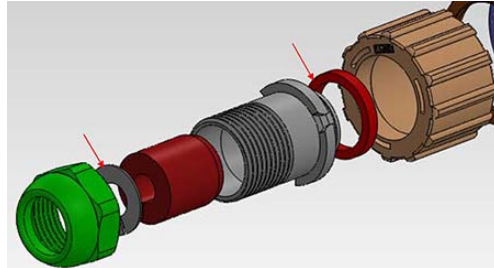

- ◆ Seat the O-ring (shown in red) on the connector body (gray) at its RJ45 jack side.
- ◆ Note the slots in the collar of the connector body and the matching tabs inside the connector ring. Insert the connector body into the connector ring so that they mate.

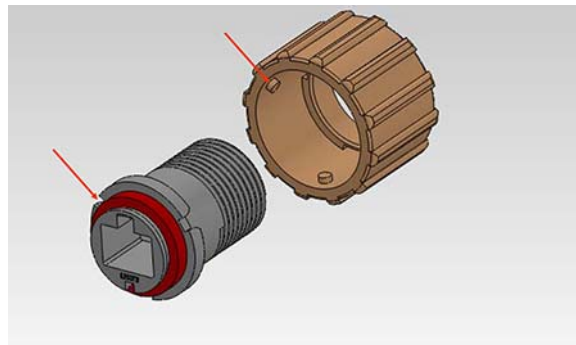
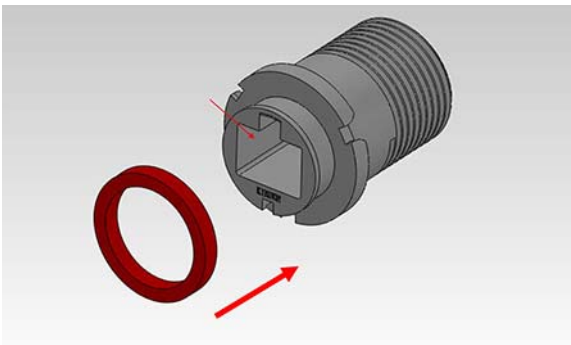

- ◆ Slide the sealing nut (shown in green) and the connector body assembly over the Ethernet cable as shown.
- ◆ Attach the split washer and split rubber grommet over the cable.
- ◆ Seat the washer in the sealing nut and slide the grommet into the connector body.

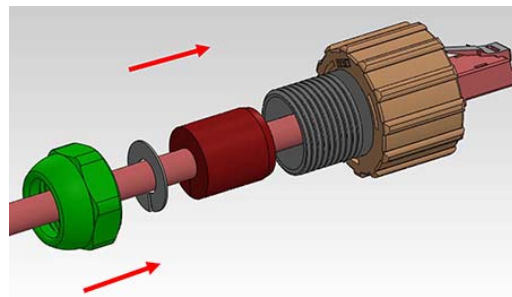
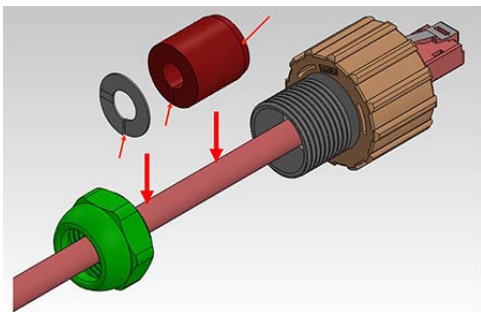

XH Outdoor Access Points

- ◆ Snug all of the components together as shown, but leave the RJ45 connector protruding. Tighten the sealing nut lightly, making sure that the RJ45 connector is rotated so that it will seat easily in the connector body later.

NOTE: Once you connect the AP's GIG1/POE port, an automatic upgrade typically starts soon after the AP has Internet connectivity. Do not unplug this port while booting or during the upgrade process or the AP may become inoperable. The upgrade should take 10 minutes or less depending on bandwidth.

- ◆ Plug the RJ45 connector into the GIG1 POE+ port on the bottom of the XH2-120, making sure that its tab clicks in place for a secure connection. If power is being properly supplied to the AP, the LED located between the two Ethernet ports will show blinking green. When the boot has successfully completed, the LED will be solid green.

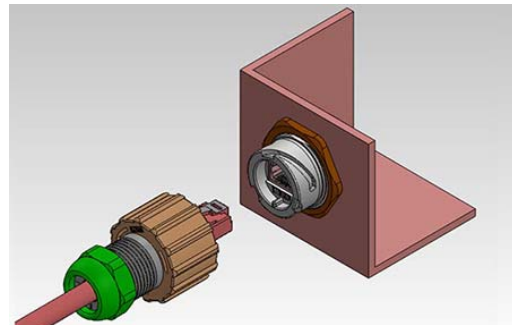
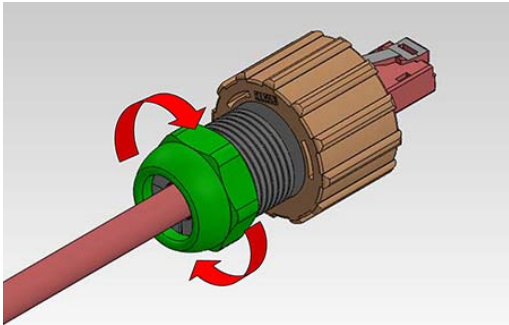

- ◆ Seat the RJ45 connector correctly in the connector body.
- ◆ Note the slotted track in the connector ring on the bottom of the AP and the matching tabs inside the connector ring in the waterproof connector assembly, below. Screw the assembly onto the AP's connector ring so that they mate securely.

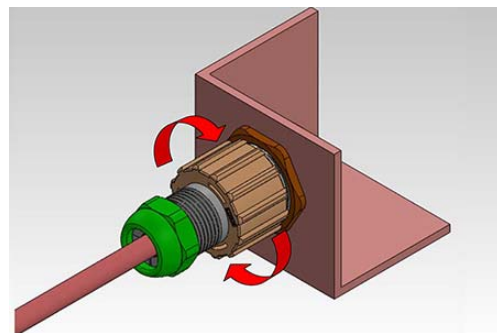
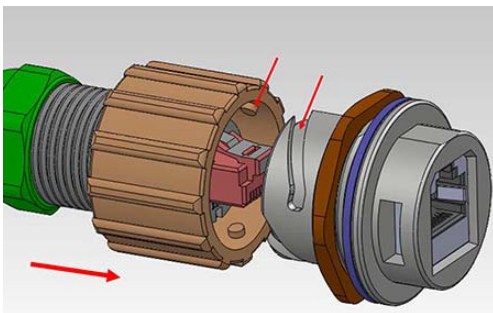

- ◆ Snug all the sections of the assembly together a final time and tighten the sealing nut on the end to 5kg but not more than 8kg torque force to insure a water tight fit.
- ◆ Repeat for the GIG2 port, if you are using it.

9

Connect the Antenna

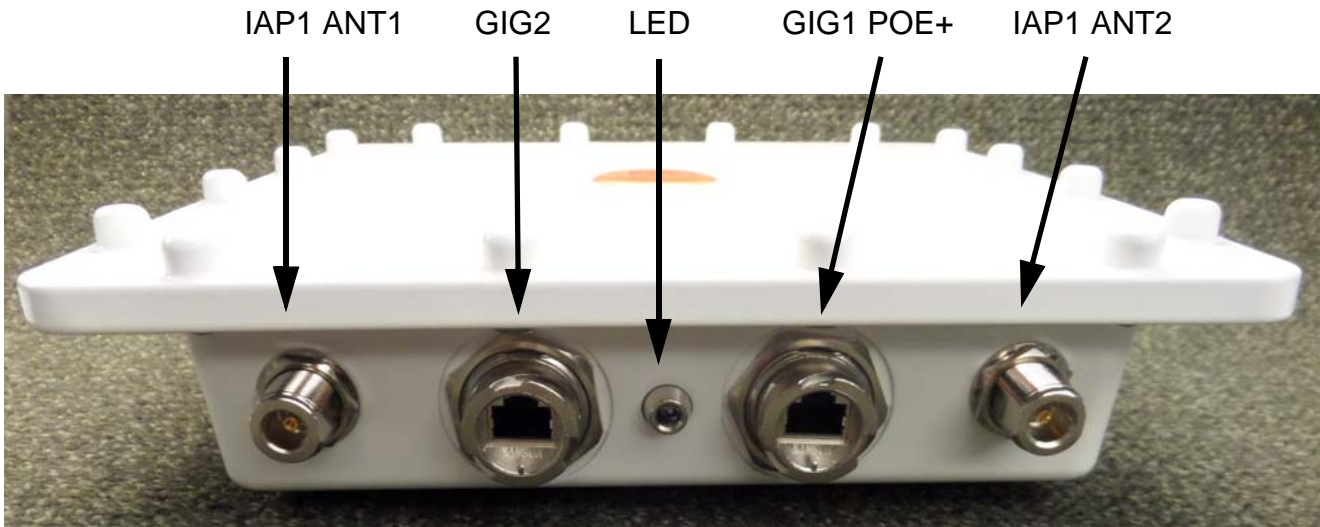

The XH2-120 has four male Type N connectors for the antennas.

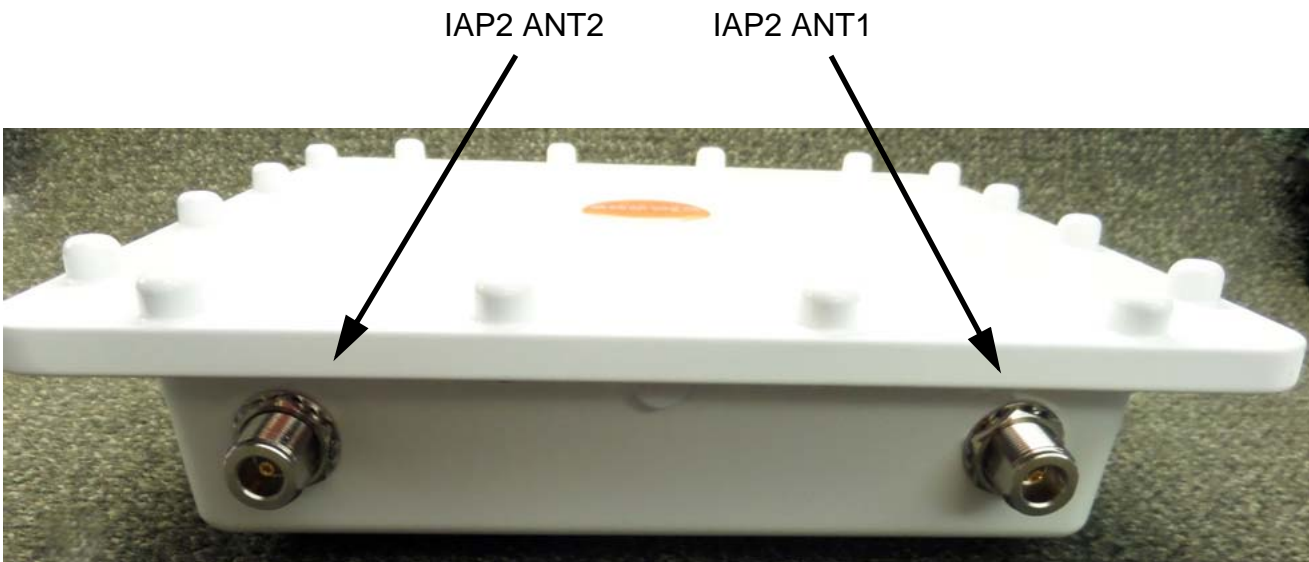

Both of the AP's RADIO1 cables (RADIO1 ANT1 and RADIO1 ANT2) must be attached to antenna leads for the same frequency band (for example, 2.4GHz), and RADIO1 must be set to that band on the AP (see Step 10). Similarly, both RADIO2 cables need to go to the same frequency band on the antenna (for example, 5GHz). For simplicity, if you are using an antenna with two 2.4GHz leads and two 5GHz leads, we suggest that you connect RADIO1 (ANT1 and

ANT2) to 2.4GHz on the antenna, and connect RADIO2 (ANT1 and ANT2) to 5GHz. Then you must configure the AP to correspond in Step 10—set RADIO1 to the 2.4GHz band and RADIO2 to the 5GHz band.

NOTE: To use a 3x3 MIMO antenna type with the XH2-120, connect to the +45 and -45 antenna outputs. Do not use the connector marked “V”.

NOTE: For some MIMO omni-directional antennas where each of the individual antennas is dual-band, it does not matter which lead is connected to which connector on the AP. For example, the Xirrus ANT-OMNI-2x2-02 has four antenna leads that are not differentiated in any way. The labels on all the leads are the same since each antenna is dual-band and omni-directional.

10

Zero-Touch Provisioning and Ongoing Management

Most customers employ the Xirrus Management System (XMS) for the initial setup and continuing management of Xirrus devices. XMS users can readily set up their new devices for zero-touch provisioning and ongoing maintenance via the following platforms. Wait five minutes after powering up the AP to automatically discover it, then use XMS to view and manage it. Newly discovered APs are automatically assigned to the XMS “default” profile, and will receive the configuration defined for that profile.

- ◆ XMS-Cloud—performs zero-touch provisioning as shown in this quick video guide: <http://www.xirrus.com/TV/Training/XMS-cloud-Next-Generation>. Your new APs appear in XMS even before you receive your equipment. When the email arrives with your login information, use XMS-Cloud to specify the initial settings for your APs. A Guided Tour will walk you through the basic steps of creating a profile containing configuration settings, including creating SSIDs and firewall/application control rules. Once the installed AP has Internet connectivity, it will automatically contact Xirrus for cloud-based zero-touch provisioning per your settings, install the latest applicable license, and upgrade the AP to the latest software version as appropriate.
- ◆ XMS-Enterprise—automatically detects and provisions new Xirrus devices deployed in your network via a similar zero-touch provisioning approach. Create and configure a default profile for newly added APs—these new devices will automatically receive the configuration defined in your default profile.
- ◆ If you are not using XMS, please see the *Xirrus Wireless AP User’s Guide* to configure your AP manually via the Express Setup menu option. The User Guide is available from <http://support.xirrus.com> (login required). Select the Libraries tab and click the ArrayOS—XR Platform Latest Release link.

11

Physical/Environmental Specifications

- Operating Temperature: -20 to +55°C / -4 to 131°F, 0-90% humidity, non-condensing.

XH2-120 Dimensions

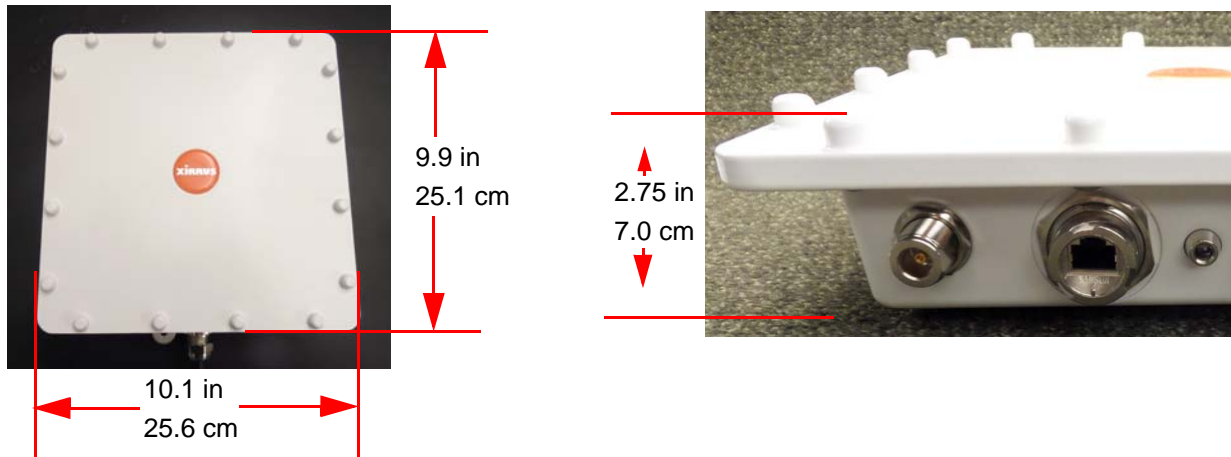

Note: Depth (2.75 in) includes the height of the protrusions built into the top and bottom of unit for screws.

Mounting Bracket Dimensions

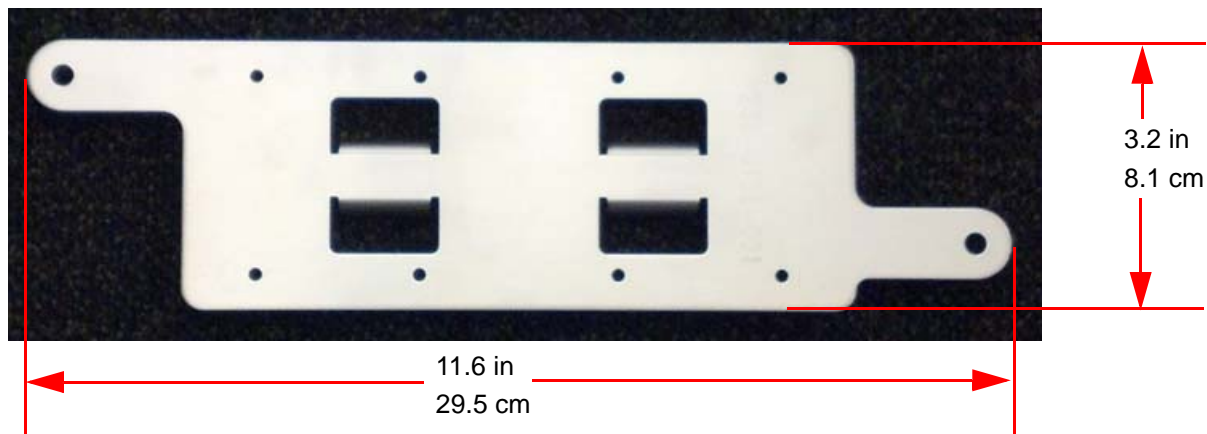

Notices, Warnings & Compliance Statements

Notices

- ◆ Read all user documentation before powering this device. Please verify the integrity of the system ground prior to installing Xirrus equipment. Additionally, verify that the ambient operating temperature does not exceed 55°C.
- ◆ Software used by the modular Access Points (APs) is covered by the Xirrus Software License and Product Warranty Agreement.
- ◆ Non-Modification Statement: Unauthorized changes or modifications to the device are not permitted. Use only Xirrus-approved external antennas supplied or recommended by the manufacturer. Modifications to the device will void the warranty and may violate FCC regulations.
- ◆ UL Statement: Use only with listed ITE product.
- ◆ Operating Frequency: The operating frequency in a wireless LAN is determined by the access point. It is important that the access point is correctly configured to meet the local regulations. If you have questions regarding the compliance of Xirrus products, please contact us at: Xirrus, Inc., 2101 Corporate Center Drive, Thousand Oaks, CA 91320, USA. Tel: 1.805.262.1600/1.800.947.7871 Toll Free in the US, Fax: 1.866.462.3980, www.xirrus.com.
- ◆ The 2-GHz b/g/n radio operates in 2.4 GHz ISM band. It supports channels 1-11 in US, 1-13 in Europe, and 1-13 in Japan. It has two transmitters with a maximum total output power of 25dBm for 802.11b/g/n operation. Output power is configurable to 5 levels. It has three receivers that enables maximum-ratio combining (MRC).
- ◆ The 5-GHz a/n radio operates in the UNII-2 band (5.25 - 5.35 GHz), UNII-2 Extended/ETSI band (5.47 - 5.725 GHz), and the upper ISM band (5.725 - 5.850 GHz). It has two transmitters with a maximum total output power of 26 dBm for UNII-2 and Extended/ETSI bands for the A-domain. The total maximum output power for the upper ISM band is 28 dBm for A-domain. Power settings will change depending on the regulatory domain.
- ◆ High power radars are allocated as primary users (meaning they have priority) in the 5250MHz to 5350MHz and 5650MHz to 5850MHz bands. These radars could cause interference and/or damage Wireless LAN devices.
- ◆ Calculating the Maximum Output Power: The regulatory limits for maximum output power are specified in EIRP (equivalent isotropic radiated power). The EIRP level of a device can be calculated by adding the gain of the antenna used (specified in dBi) to the output power available at the connector (specified in dBm).

Warnings

GENERAL SAFETY GUIDELINES

! **WARNING:** This warning symbol means danger. You are in a situation that could cause bodily injury. Before you work on any equipment, be aware of the hazards involved with electrical circuitry and be familiar with standard practices for preventing accidents.

! **WARNING:** Only trained and qualified personnel should be allowed to install, replace, or service this equipment.

! **WARNING:** Ultimate disposal of this product should be handled according to all national laws and regulations.

! **WARNING:** Incorrect installation of Xirrus Access Points may invalidate FCC, CE mark, or other regulatory compliance approvals. Customers are responsible for any legal violations from operation of un-approved equipment or incorrect installation.

! **WARNING:** Do not operate the Access Point near unshielded blasting caps or in an explosive environment unless the device has been modified to be especially qualified for such use.

! **CAUTION:** Supplied watertight adapters must be used on all input/output connections to the Access Point.

! **CAUTION:** RISK OF EXPLOSION IF BATTERY IS REPLACED BY AN INCORRECT TYPE.
DISPOSE OF USED BATTERIES ACCORDING TO THE MANUFACTURER'S INSTRUCTIONS.

POWER

! **WARNING:** Read the installation instructions before connecting the system to the power source.

! **WARNING:** Installation of the equipment must comply with local and national electrical codes.

! **WARNING:** This equipment must be externally grounded using a customer-supplied ground wire before power is applied. Contact the appropriate electrical inspection authority or an electrician if you are uncertain that suitable grounding is available.

! **WARNING:** Do not work on the system or connect or disconnect cables during periods of lightning activity.

! **WARNING:** To ensure proper PoE power is delivered to the Access Point, use only No. 26 AWG or larger Ethernet (Shielded CAT5E, CAT6) cable.

! **CAUTION:** When the Access Point is installed outdoors or in a wet or damp location, the AC branch circuit that is powering the Injector should be provided with ground fault protection (GFCI), as required by Article 210 of the National Electrical Code (NEC).

! **CAUTION:** Xirrus PoE Injectors rely on the building's installation for over current protection. Ensure that a fuse or circuit breaker no larger than 120 VAC, 15A (U.S.) or 240 VAC, 10A (International) is used on all current-carrying conductors.

EXTERNAL ANTENNAS

- ! **WARNING:** In order to comply with radio frequency (RF) exposure limits, the antennas for this product should be positioned no less than 26 cm from your body or nearby persons.

- ! **WARNING:** Do not locate the antenna near overhead power lines or other electric light or power circuits, or where it can come into contact with such circuits. When installing the antenna, take extreme care not to come into contact with such circuits, because they may cause serious injury or death. For proper installation and grounding of the antenna, please refer to national and local codes (for example, U.S.:NFPA 70, National Electrical Code, Article 810, Canada: Canadian Electrical Code, Section 54).

- ! This device has been designed to operate with antennas having an effective maximum gain of 8dBi in the 2.4 GHz band and 8dBi in the 5 GHz band. Antennas having a gain greater than this are strictly prohibited for use with this device. The required antenna impedance is 50 ohms. Effective maximum gain is antenna gain minus cable loss.

- ! To reduce potential radio interference to other users, the antenna type and its gain should be so chosen that the equivalent isotropically radiated power (EIRP) is not more than that permitted for successful communication.

Wi-Fi Alliance Certification



www.wi-fi.org

Federal Communications Commission (FCC) Statements & Instructions

FCC Declaration of Conformity Statement

This device complies with Part 15 of the FCC Rules, with operation subject to the following two conditions: (1) This device may not cause harmful interference, and (2) this device must accept any interference received, including interference that may cause unwanted operation.

This equipment has been tested and found to comply with the limits for a Class B digital device, pursuant to Part 15 of the FCC rules. These limits are designed to provide reasonable protection against harmful interference in a residential installation. This equipment generates, uses and can radiate RF energy and, if not installed and used in accordance with the instructions, may cause harmful interference to radio communications. However, there is no guarantee that interference will not occur in a particular installation. If this equipment does cause harmful interference to radio or television reception, which can be determined by turning the equipment off and on, the user is encouraged to try to correct the interference by one or more of the following safety measures:

- ◆ Reorient or relocate the receiving antenna.
- ◆ Increase the separation between the equipment and the receiver.

XH Outdoor Access Points

- ◆ Connect the equipment into an outlet on a circuit different from that to which the receiver is connected.
- ◆ Consult the dealer or an experienced wireless technician for help.

Consult the dealer or an experienced wireless technician for help. Shielded twisted pair (STP) cable must be used for all Ethernet connections in order to comply with EMC requirements.

FCC Caution: Any changes or modifications not expressly approved by the party responsible for compliance could void the user's authority to operate this equipment.

FCC-Specific Instructions

The FCC, National Telecommunications and Information Administration (NTIA), Federal Aviation Administration (FAA), and industry are working to resolve interference to Terminal Doppler Weather Radar (TDWR) systems used near airports that has occurred from some outdoor wireless systems operating in the 5470 MHz - 5725 MHz band. These wireless devices are subject to Section 15.407 of our rules and while operating as a master device they are required to implement radar detection and Dynamic Frequency Selection (DFS) functions.

- ◆ Devices must be professionally installed.
- ◆ Any installation of either a master or a client device within 35 km of a TDWR location shall be separated by at least 30 MHz (center-to-center) from the TDWR operating frequency (as shown in the TDWR location at <http://www.spectrumbridge.com/udia/home.aspx>). This will require that channel 116 is not used in these locations.
- ◆ The installers and the operators must register the devices in the industry-sponsored database with the appropriate information regarding the location and operation of the device and installer information. A voluntary Wireless Internet Service Providers Association (WISPA) sponsored database has been developed that allows operators and installers to register the location information of the Unlicensed National Information Infrastructure (UNII) devices operating outdoors in the 5470 - 5725 MHz band within 35 km of any TDWR location (see <http://www.spectrumbridge.com/udia/home.aspx>). This database may be used by government agencies to expedite resolution of any interference to TDWRs.

FCC Safety Compliance Statement

The FCC with its action in ET Docket 96-8 has adopted a safety standard for human exposure to radio frequency (RF) electromagnetic energy emitted by FCC certified equipment. When used with approved Xirrus antennas, Xirrus Wireless products meet the uncontrolled environmental limits found in OET-65 and ANSI C95.1, 1991. Proper installation of this radio according to the instructions found in this manual will result in user exposure that is substantially below the FCC recommended limits.

Industry Canada Statements and Warnings

Industry Canada Notice and Marking: This Class B digital apparatus complies with Canadian ICES-003.

Cet appareil numérique de la classe A est conforme à la norme NMB-003 du Canada.

The term “IC:” before the radio certification number only signifies that Industry Canada technical specifications were met.

Under Industry Canada regulations, this radio transmitter may only operate using an antenna of a type and maximum (or lesser) gain approved for the transmitter by Industry Canada. To reduce potential radio interference to other users, the antenna type and its gain should be so chosen that the equivalent isotropically radiated power (e.i.r.p.) is not more than that necessary for successful communication.

Conformément à la réglementation d'Industrie Canada, le présent émetteur radio peut fonctionner avec une antenne d'un type et d'un gain maximal (ou inférieur) approuvé pour l'émetteur par Industrie Canada. Dans le but de réduire les risques de brouillage radioélectrique à l'intention des autres utilisateurs, il faut choisir le type d'antenne et son gain de sorte que la puissance isotrope rayonnée équivalente (p.i.r.e.) ne dépasse pas l'intensité nécessaire à l'établissement d'une communication satisfaisante.

This device complies with Industry Canada license-exempt RSS standard(s). Operation is subject to the following two conditions: (1) this device may not cause interference, and (2) this device must accept any interference, including interference that may cause undesired operation of the device.

Le présent appareil est conforme aux CNR d'Industrie Canada applicables aux appareils radio exempts de licence. L'exploitation est autorisée aux deux conditions suivantes: (1) l'appareil ne doit pas produire de brouillage, et (2) l'utilisateur de l'appareil doit accepter tout brouillage radioélectrique subi, même si le brouillage est susceptible d'en compromettre le fonctionnement.

Xirrus Access Points are certified to the requirements of RSS-210. The use of this device in a system operating either partially or completely outdoors may require the user to obtain a license for the system according to the Canadian regulations. For further information, contact your local Industry Canada office.

RF Radiation Hazard Warning: To ensure compliance with FCC and Industry Canada RF exposure requirements, this device must be installed in a location where the antennas of the device will have a minimum distance of at least 26 cm from all persons. Using higher gain antennas and types of antennas not certified for use with this product is not allowed. The device shall not be co-located with another transmitter.

Installez l'appareil en veillant à conserver une distance d'au moins 26 cm entre les éléments rayonnants et les personnes. Cet avertissement de sécurité est conforme aux limites d'exposition définies par la norme CNR-102 relative aux fréquences radio.

High Power Radars: High power radars are allocated as primary users (meaning they have priority) in the 5250MHz to 5350MHz and 5650MHz to 5850MHz bands. These radars could cause interference and/or damage to Wireless LAN devices used in Canada.

Les utilisateurs de radars de haute puissance sont désignés utilisateurs principaux (c.-à-d., qu'ils ont la priorité) pour les bandes 5 250 - 5 350 MHz et 5 650 - 5 850 MHz. Ces radars pourraient causer du brouillage et/ou des dommages aux dispositifs LAN-EL.

EU Directive 1999/5/EC Compliance Information

This section contains compliance information for the Xirrus Wireless Access Point family of products. The compliance information contained in this section is relevant to the European Union and other countries that have implemented the EU Directive 1999/5/EC.

This declaration is only valid for configurations (combinations of software, firmware and hardware) provided and/or supported by Xirrus Inc. The use of software or firmware not supported/provided by Xirrus Inc. may result that the equipment is no longer compliant with the regulatory requirements.

Declaration of Conformity

Cesky [Czech] Toto zařízení je v souladu se základními požadavky a ostatními odpovídajícími ustanoveními Směrnice 1999/5/EC.

Dansk [Danish] Dette udstyr er i overensstemmelse med de væsentlige krav og andre relevante bestemmelser i Direktiv 1999/5/EF.

Deutsch [German] Dieses Gerät entspricht den grundlegenden Anforderungen und den weiteren entsprechenden Vorgaben der Richtlinie 1999/5/EU.

Eesti [Estonian] See seade vastab direktiivi 1999/5/EU olulistele nõuetele ja teistele asjakohastele sätetele.

English This equipment is in compliance with the essential requirements and other relevant provisions of Directive 1999/5/EC.

Español [Spain] Este equipo cumple con los requisitos esenciales así como con otras disposiciones de la Directiva 1999/5/CE.

Ελληνική [Greek] Αυτό ο εξοπλισμός είναι σε συμμόρφωση με τις ουσιαστικές απαιτήσεις και άλλες σχετικές διατάξεις της Οδηγίας 1999/5/EC.

Français [French] Cet appareil est conforme aux exigences essentielles et aux autres dispositions pertinentes de la Directive 1999/5/EC.

Íslenska [Icelandic] Þetta tæki er samkvæmt grunnkröfum og öðrum viðeigandi ákvæðum Tilskipunar 1999/5/EC.

Italiano [Italian] Questo apparato é conforme ai requisiti essenziali ed agli altri principi sanciti dalla Direttiva 1999/5/CE.

Latviski [Latvian] Šī iekārta atbilst Direktīvas 1999/5/EK būtiskajā prasībām un citiem ar to saistītajiem noteikumiem.

Lietuvių [Lithuanian] Šis įrenginys tenkina 1995/5/EB Direktyvos esminius reikalavimus ir kitas šios direktyvos nuostatas.

Nederlands [Dutch] Dit apparant voldoet aan de essentiële eisen en andere van toepassing zijnde bepalingen van de Richtlijn 1995/5/EC.

Malti [Maltese] Dan l-apparant huwa konformi mal-htigiet essenzjali u l-provedimenti l-ohra rilevanti tad-Direttiva 1999/5/EC.

Magyar [Hungarian] Ez a készülék teljesíti az alapvető követelményeket és más 1999/5/EK irányelvben meghatározott vonatkozó rendelkezéseket.

Norsk [Norwegian] Dette utstyret er i samsvar med de grunnleggende krav og andre relevante bestemmelser i EU-direktiv 1999/5/EF.

Polski [Polish] Urządzenie jest zgodne z ogólnymi wymaganiami oraz szczególnymi mi warunkami określony mi Dyrektywą. UE:1999/5/EC.

Português [Portuguese] Este equipamento está em conformidade com os requisitos essenciais e outras provisões relevantes da Directiva 1999/5/EC.

Slovensko [Slovenian] Ta naprava je skladna z bistvenimi zahtevami in ostalimi relevantnimi popoji Direktive 1999/5/EC.

Slovensky [Slovak] Toto zariadenie je v zhode so základnými požadavkami a inými príslušnými nariadeniami direktiv: 1999/5/EC.

Suomi [Finnish] Tämä laite täyttää direktiivin 1999/5//EY olennaiset vaatimukset ja on siinä asetettujen muiden laitetta koskevien määräysten mukainen.

Svenska [Swedish] Denna utrustning är i överensstämmelse med de väsentliga kraven och andra relevanta bestämmelser i Direktiv 1999/5/EC.

Assessment Criteria: The following standards were applied during the assessment of the product against the requirements of the Directive 1999/5/EC:

- ◆ Radio: EN 301 893 and EN 300 328 (if applicable)
- ◆ EMC: EN 301 489-1 and EN 301 489-17
- ◆ Safety: EN 50385
- ◆ RF Exposure: EN 62479

CE Marking: For the Xirrus Wireless Access Point, the CE mark and Class-2 identifier opposite are affixed to the equipment and its packaging:



WEEE Compliance: Natural resources were used in the production of this equipment.



- ◆ This equipment may contain hazardous substances that could impact the health of the environment.
- ◆ If you need more information on collection, re-use and recycling systems, please contact your local or regional waste administration.
- ◆ Please contact Xirrus for specific information on the environmental performance of our products.

National Restrictions: In the majority of the EU and other European countries, the 2.4 GHz and 5 GHz bands have been made available for the use of Wireless LANs. The following table provides an overview of the regulatory requirements in general that are applicable for the 2.4 GHz and 5 GHz bands.

Frequency Band (MHz)	Max Power Level (EIRP) (mW)	Indoor	Outdoor
2400-2483.5	100	X	X**
5250-5359*	200	X	N/A
5470-5725	1000	X	X

**Dynamic frequency selection and Transmit Power Control is required in these frequency bands.*

***France is indoor use only in the upper end of the band.*

The requirements for any country may change at any time. Xirrus recommends that you check with local authorities for the current status of their national regulations for both 2.4 GHz and 5 GHz wireless LANs. The following countries have additional requirements or restrictions than those listed in the above table:

Belgium: The Belgian Institute for Postal Services and Telecommunications (BIPT) must be notified of any outdoor wireless link having a range exceeding 300 meters. Xirrus recommends checking at www.bipt.be for more details.

Draadloze verbindingen voor buitengebruik en met een reikwijdte van meer dan 300 meter dienen aangemeld te worden bij het Belgisch Instituut voor postdiensten en telecommunicatie (BIPT). Zie www.bipt.be voor meer gegevens.

Les liaisons sans fil pour une utilisation en extérieur d'une distance supérieure à 300 mètres doivent être notifiées à l'Institut Belge des services Postaux et des Télécommunications (IBPT). Visitez www.bipt.be pour de plus amples détails.

Greece: A license from EETT is required for the outdoor operation in the 5470 MHz to 5725 MHz band. Xirrus recommends checking www.eett.gr for more details.

Η δη ιουργβάικτ ωνεξωτερικο ρουστη ζ νησυ νοτ των 5470–5725 MHz ε ιτρ ετάιωνο ετάά όάδειά της EETT, ου ορηγεβτάι στερά ά ό σ φωνη γν η του ΓΕΕΘΑ. Ερισσότερες λε τομ ρειεωστο www.eett.gr

Italy: This product meets the National Radio Interface and the requirements specified in the National Frequency Allocation Table for Italy. Unless this wireless LAN product is operating within the boundaries of the owner's property, its use requires a “general authorization.” Please check with www.comunicazioni.it/it/ for more details.

Questo prodotto é conforme alla specifiche di Interfaccia Radio Nazionali e rispetta il Piano Nazionale di ripartizione delle frequenze in Italia. Se non viene installato all'interno del proprio fondo, l'utilizzo di prodotti wireless LAN richiede una "autorizzazione Generale." Consultare www.comunicazioni.it/it/ per maggiori dettagli.

Norway, Switzerland and Liechtenstein: Although Norway, Switzerland and Liechtenstein are not EU member states, the EU Directive 1999/5/EC has also been implemented in those countries.

RF Exposure

Generic Information

The Xirrus Access Point products are designed to comply with the following national and international standards on Human Exposure to Radio Frequencies:

- ◆ US 47 Code of Federal Regulations Part 2 Subpart J
- ◆ American National Standards Institute (ANSI) / Institute of Electrical and Electronic Engineers / IEEE C 95.1 (99)
- ◆ International Commission on Non Ionizing Radiation Protection (ICNIRP) 98

XH Outdoor Access Points

- ♦ Ministry of Health (Canada) Safety Code 6. Limits on Human Exposure to Radio Frequency Fields in the range from 3kHz to 300 GHz
- ♦ Australia Radiation Protection Standard

To ensure compliance with various national and international Electromagnetic Field (EMF) standards, the system should only be operated with Xirrus approved antennas and accessories.

Declaration on Conformity

This access point product has been found to be compliant to the requirements set forth in CFR 47 Section 1.1307 addressing RF Exposure from radio frequency devices as defined in Evaluating Compliance with FCC Guidelines for Human Exposure to Radio Frequency Electromagnetic Fields.

Use is permitted with antennas having an effective maximum gain of 9 dBi in the 2.4 GHz band and 6 dBi in the 5 GHz band. Antennas having a gain greater than this are strictly prohibited for use with this device. The required antenna impedance is 50 ohms. Effective maximum gain is antenna gain minus cable loss. A minimum separation distance of 26 cm between the antenna and all persons is required during normal operation.

Only antennas provided by Xirrus for use with the product should be installed. The use of any other antennas may cause damage to the access points or violate regulatory emission limits and will not be supported by Xirrus.

International Guidelines for Exposure to Radio Waves

The Xirrus Access Points include radio transmitters and receivers. It is designed not to exceed the limits for exposure to radio waves (radio frequency electromagnetic fields) recommended by international guidelines. The guidelines were developed by an independent scientific organization (ICNIRP) and include a substantial safety margin designed to ensure the safety of all persons, regardless of age and health.

As such the systems are designed to be operated as to avoid contact with the antennas by the end user. It is recommended to set the system in a location where the antennas can remain at least a minimum distance as specified from the user in accordance to the regulatory guidelines which are designed to reduce the overall exposure of the user or operator.

Separation Distance		
MPE	Distance	Limit
1.34 mW/cm ²	26 cm	1.00 mW/cm ²

The World Health Organization has stated that present scientific information does not indicate the need for any special precautions for the use of wireless devices. They recommend that if you are interested in further reducing your exposure then you can easily do so by reorienting

antennas away from the user or placing the antennas at a greater separation distance than recommended.

FCC Guidelines for Exposure to Radio Waves

The device includes a radio transmitter and receiver. It is designed not to exceed the limits for exposure to radio waves (radio frequency electromagnetic fields) as referenced in FCC Part 1.1310. The guidelines are based on IEEE ANSI C 95.1 (92) and include a substantial safety margin designed to ensure the safety of all persons, regardless of age and health.

As such the systems are designed to be operated as to avoid contact with the antennas by the end user. It is recommended to set the system in a location where the antennas can remain at least a minimum distance as specified from the user in accordance to the regulatory guidelines which are designed to reduce the overall exposure of the user or operator.

Separation Distance		
MPE	Distance	Limit
1.34 mW/cm ²	26 cm	100 mW/cm ²

The device has been tested and found compliant with the applicable regulations as part of the radio certification process.

The US Food and Drug Administration has stated that present scientific information does not indicate the need for any special precautions for the use of wireless devices. The FCC recommends that if you are interested in further reducing your exposure then you can easily do so by reorienting antennas away from the user or placing the antennas at a greater separation distance than recommended or lowering the transmitter power output.

Industry Canada Guidelines for Exposure to Radio Waves

The Xirrus Access Points include radio transmitters and receivers. It is designed not to exceed the limits for exposure to radio waves (radio frequency electromagnetic fields) as referenced in Health Canada Safety Code 6. The guidelines include a substantial safety margin designed into the limit to ensure the safety of all persons, regardless of age and health.

As such the systems are designed to be operated as to avoid contact with the antennas by the end user. It is recommended to set the system in a location where the antennas can remain at

XH Outdoor Access Points

least a minimum distance as specified from the user in accordance to the regulatory guidelines which are designed to reduce the overall exposure of the user or operator.

Separation Distance		
MPE	Distance	Limit
1.34 mW/cm ²	26 cm	100 mW/cm ²

Health Canada states that present scientific information does not indicate the need for any special precautions for the use of wireless devices. They recommend that if you are interested in further reducing your exposure you can easily do so by reorienting antennas away from the user, placing the antennas at a greater separation distance than recommended, or lowering the transmitter power output.

Additional Information on RF Exposure

You can find additional information on the subject at the following links:

- ◆ FCC Bulletin 56: Questions and Answers about Biological Effects and Potential Hazards of Radio Frequency Electromagnetic Fields
- ◆ FCC Bulletin 65: Evaluating Compliance with the FCC guidelines for Human Exposure to Radio Frequency Electromagnetic Fields
- ◆ FCC Bulletin 65C (01-01): Evaluating Compliance with the FCC guidelines for Human Exposure to Radio Frequency Electromagnetic Fields: Additional Information for Evaluating Compliance for Mobile and Portable Devices with FCC limits for Human Exposure to Radio Frequency Emission

You can obtain additional information from the following organizations:

- ◆ World Health Organization Internal Commission on Non-Ionizing Radiation Protection at this URL: www.who.int/emf
- ◆ United Kingdom, National Radiological Protection Board at this URL: www.nrp.org.uk
- ◆ Cellular Telecommunications Association at this URL: www.wow-com.com
- ◆ The Mobile Manufacturers Forum at this URL: www.mmfa.org

Customer Support

The Xirrus Customer Support Website provides online documents and tools for troubleshooting and resolving technical issues with Xirrus products and technologies. Access to all tools on the Xirrus Customer Support Website requires a login user ID and password. If you have a valid service contract but do not have a user ID or password, you can register at this URL: <http://support.xirrus.com>

To request additional assistance, please contact Xirrus Customer Support via

- ◆ Email at support@xirrus.com
- ◆ Live chat with one of the Xirrus Customer Support Representatives at <http://support.xirrus.com>
- ◆ Call Xirrus at the following numbers:

United States and Canada	+1.800.947.7871 (US Toll Free) or +1.805.262.1600 (Direct)
Europe, Middle East, and Africa	+44.20.3239.8644
Australia	1.300.947.787 (Within Australia)
Asia and Oceania	+61.2.8006.0622
Latin, Central, and South America	+1.805.262.1600



1.800.947.7871 Toll Free in the US
+1.805.262.1600 Sales
+1.805.262.1601 Fax
2101 Corporate Center Drive
Thousand Oaks, CA 91320, USA

To learn more visit:
xirrus.com or
email info@xirrus.com