

# TEST REPORT



of

FCC Part 15 Subpart C §15.247

FCC ID : SJ9CS-WDP06G

Equipment Under Test : Network Camera  
Model Name : CS-WDP06G  
Serial No. : N/A  
Applicant : Planex Communications Inc.  
Manufacturer : SAMSUNG ELECTRO-MECHANICS CO., LTD.  
Date of Test(s) : 2011.01.31 ~ 2011.02.23  
Date of Issue : 2011.02.25

In the configuration tested, the EUT complied with the standards specified above.

Tested By:		Date	2011.02.25
	_____		_____
	Duke Ko		
Approved By		Date	2011.02.25
	_____		_____
	Feel Jeong		

*The results shown in this test report refer only to the sample(s) tested unless otherwise stated. This test report cannot be reproduced, except in full, without prior written permission of the Company.*

---

# INDEX

## Table of contents

1. General information -----	3
2. Transmitter radiated spurious emissions and conducted spurious emission -----	6
3. 6 dB bandwidth -----	20
4. Maximum peak output power -----	25
5. Power Spectral Density -----	27
6. Transmitter AC Power Line Conducted Emission-----	32
7. Antenna Requirement -----	37
8. RF Exposure evaluation -----	38

---

*The results shown in this test report refer only to the sample(s) tested unless otherwise stated. This test report cannot be reproduced, except in full, without prior written permission of the Company.*

## 1. General Information

### 1.1. Testing Laboratory

SGS Testing Korea Co., Ltd.  
 - Wireless Div. 2FL, 18-34, Sanbon-dong, Gunpo-si, Gyeonggi-dong, Korea  
 - 705, Dongcheon-dong Suji-gu, Yongin-si, Gyeonggi-do, Korea  
[www.electrolab.kr.sgs.com](http://www.electrolab.kr.sgs.com)  
 Telephone : +82 +31 428 5700  
 FAX : +82 +31 427 2371

### 1.2. Details of Applicant

Applicant : Planex Communications Inc.  
 Address : 2F F.Nissay Ebisu Bldg. 3-16-3 Higashi, Shibuya-ku, Tokyo 150-0011, Japan  
 Contact Person : Toru Ohnishi  
 Phone No. : +81 +3 5766 1056  
 Fax No. : +81 +3 5766 1057

### 1.3. Description of EUT

<b>Kind of Product</b>	Network Camera
<b>Model Name</b>	CS-WDP06G
<b>Serial Number</b>	N/A
<b>Power Supply</b>	AC 100 ~ 240 V
<b>Frequency Range</b>	2 412 ~ 2 462 MHz (11b/g)
<b>Modulation Technique</b>	DSSS, OFDM
<b>Number of Channels</b>	11
<b>Antenna Type</b>	Integral Type
<b>Antenna Gain</b>	1.7 dBi

### 1.4. Declaration by the manufacturer

- N/A

*The results shown in this test report refer only to the sample(s) tested unless otherwise stated. This test report cannot be reproduced, except in full, without prior written permission of the Company.*

### 1.5. Test Equipment List

EQUIPMENT	MANUFACTURER	MODEL	CAL DUE.
Signal Generator	Agilent	E4438C	Mar. 31, 2011
Signal Generator	Rohde & Schwarz	SMR40	Jul. 18, 2011
Spectrum Analyzer	R & S	FSV30	May 31, 2011
AC Power Supply	Daekwang Electronics	Slide-AC	Sep. 17, 2011
Preamplifier	H.P	8447F	Jul. 05, 2011
Preamplifier	Agilent	8449B	Apr. 01, 2011
High Pass Filter	Wainwright	WHK3.0/18G-10SS	Sep. 29, 2011
Test Receiver	R & S	ESU26	Apr. 08, 2011
Bilog Antenna	SCHWARZBECK MESSELEKTRONIK	396	Jul. 22, 2011
Horn Antenna	R & S	HF 906	Oct. 08, 2011
Horn Antenna	SCHWARZBECK MESSELEKTRONIK	BBHA9170	Mar. 17 2012
Power sensor	R & S	NRP-Z81	Aug. 14, 2011
Antenna Master	EMCO	1050	N.C.R.
Turn Table	Daeil EMC	DI-1500	N.C.R.
Anechoic Chamber	SY Corporation	L x W x H (9.6 mx6.4 mx6.6 m)	N.C.R.
Two-Line V-Network	R & S	ENV216	Jan. 04, 2012
Test Receiver	R & S	ESHS10	Jul. 13, 2011
Anechoic Chamber	SY Corporation	L x W x H (6.5 mx3.5 mx3.5 m)	N.C.R.

*The results shown in this test report refer only to the sample(s) tested unless otherwise stated. This test report cannot be reproduced, except in full, without prior written permission of the Company.*

### 1.6. Summary of Test Results

The EUT has been tested according to the following specifications:

APPLIED STANDARD:FCC Part15 subpart C		
Standard section	Test Item	Result
15.205(a) 15.209 15.247(d)	Transmitter Radiated Spurious Emissions Conducted Spurious Emission	Complied
15.247(a)(2)	6 dB Bandwidth	Complied
15.247(b)(3)	Maximum Peak Output Power	Complied
15.247(e)	Power Spectral Density	Complied
15.207	Transmitter AC Power Line Conducted Emission	Complied

### 1.7. Conclusion of worst-case

The field strength of spurious emission was measured in three orthogonal EUT positions(X-axis, Y-axis and Z-axis). Worst case is Y -axis. 1 Mbps is the highest output power in the 11b. 6 Mbps is the highest output power in the 11g.

### 1.8 Test report revision

Revision	Report number	Description
0	F690501/RF-RTL004503	Initial

*The results shown in this test report refer only to the sample(s) tested unless otherwise stated. This test report cannot be reproduced, except in full, without prior written permission of the Company.*

## 2. Transmitter Radiated Spurious Emissions and Conducted Spurious Emission

### 2.1. Test Setup

#### 2.1.1. Transmitter Radiated Spurious Emissions

The diagram below shows the test setup that is utilized to make the measurements for emission from 30 MHz to 1 GHz Emissions.

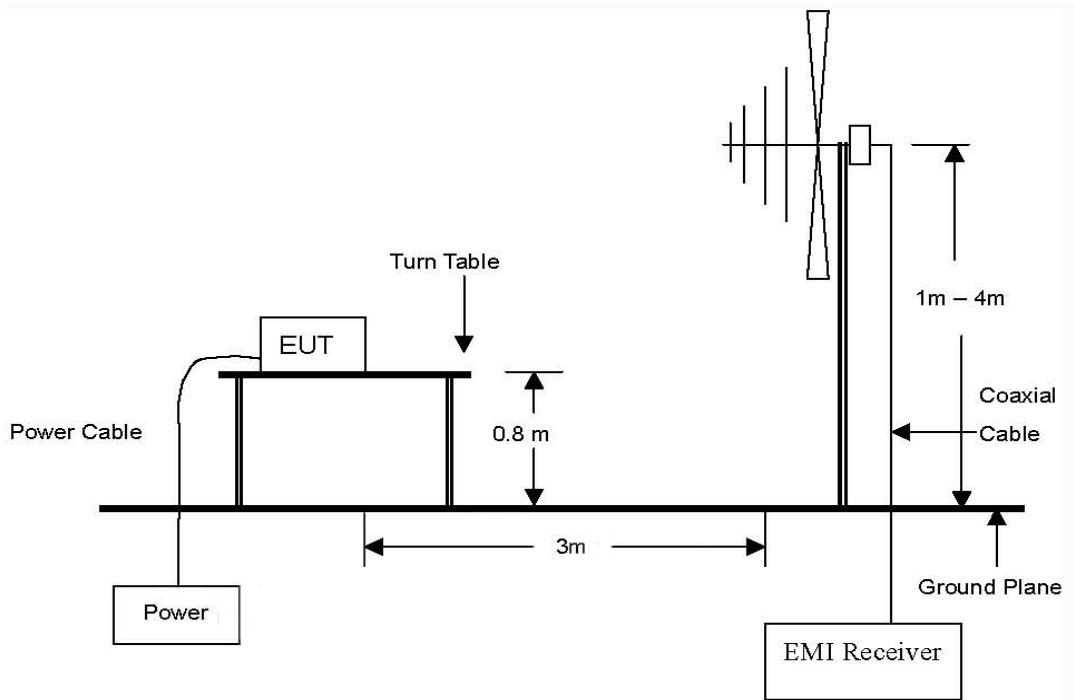

The diagram below shows the test setup that is utilized to make the measurements for emission from 1 GHz to 24 GHz Emissions.

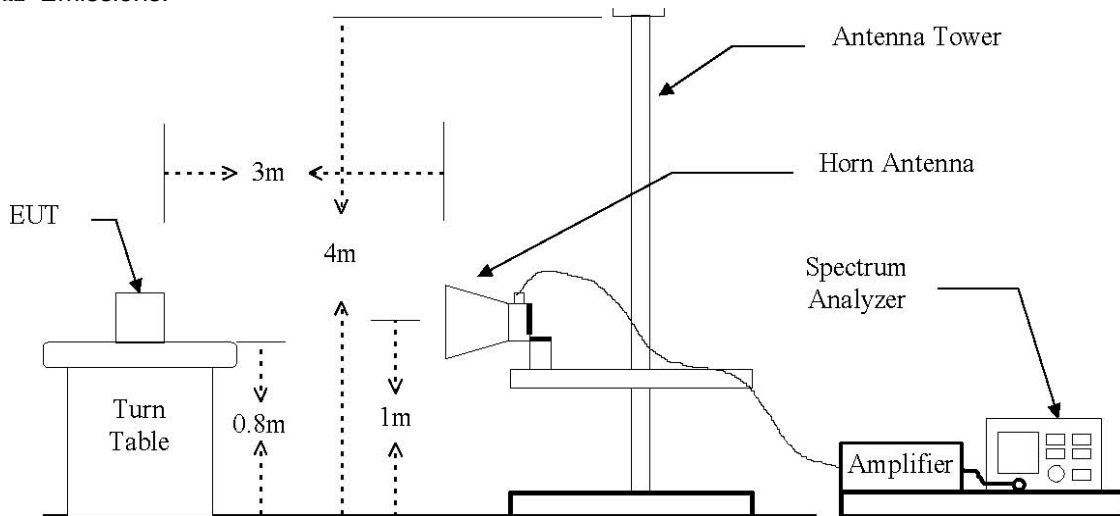

*The results shown in this test report refer only to the sample(s) tested unless otherwise stated. This test report cannot be reproduced, except in full, without prior written permission of the Company.*

### 2.1.2. Conducted Spurious Emission

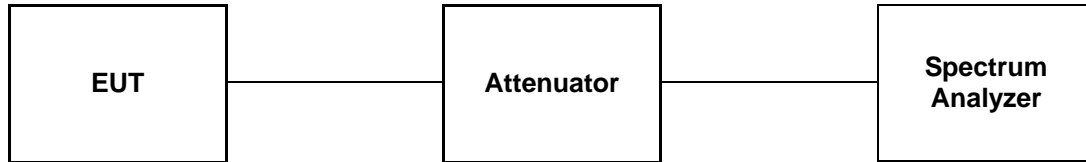

### 2.2. Limit

According to §15.247(d), in any 100 kHz bandwidth outside the frequency band in which the spread spectrum or digitally modulated intentional radiator is operating, the radio frequency power that is produced by the intentional radiator shall be at least 20 dB below that in the 100 kHz bandwidth within the band that contains the highest level of the desired power, based on either an RF conducted or a radiated measurement, provided the transmitter demonstrates compliance with the peak conducted power limits. If the transmitter complies with the conducted power limits based on the use of RMS averaging over a time interval, as permitted under paragraph(b)(3) of this section, the attenuation required under this paragraph shall be 30 dB instead of 20 dB. Attenuation below the general limits specified in section §15.209(a) is not required. In addition, radiated emission which in the restricted band, as define in section §15.205(a), must also comply the radiated emission limits specified in section §15.209(a) (see section §15.205(c))

According to § 15.209(a), Except as provided elsewhere in this Subpart, the emissions from an intentional radiator shall not exceed the field strength levels specified in the following table :

Frequency (MHz)	Distance (Meters)	Field Strength (dB $\mu$ V/m)	Field Strength ( $\mu$ V/m)
30 - 88	3	40.0	100
88 – 216	3	43.5	150
216 – 960	3	46.0	200
Above 960	3	54.0	500

*The results shown in this test report refer only to the sample(s) tested unless otherwise stated. This test report cannot be reproduced, except in full, without prior written permission of the Company.*

## 2.3. Test Procedures

Radiated emissions from the EUT were measured according to the dictates of ANSI C63.4:2003

### 2.3.1. Test Procedures for Radiated Spurious Emissions

1. The EUT was placed on the top of a rotating table 0.8 meters above the ground at a 3 meter anechoic chamber test site. The table was rotated 360 degrees to determine the position of the highest radiation.
2. During performing radiated emission below 1 GHz, the EUT was set 3 meters away from the interference receiving antenna, which was mounted on the top of a variable-height antenna tower. During performing radiated emission above 1 GHz, the EUT was set 3 meter away from the interference-receiving antenna.
3. The antenna is a broadband antenna, and its height is varied from one meter to four meters above the ground to determine the maximum value of the field strength. Both horizontal and vertical polarizations of the antenna are set to make the measurement.
4. For each suspected emission, the EUT was arranged to its worst case and then the antenna was tuned to heights from 1 meter to 4 meters and the table was turned from 0 degrees to 360 degrees to find the maximum reading.
5. The test-receiver system was set to Peak Detect Function and Specified Bandwidth with Maximum Hold Mode.
6. If the emission level of the EUT in peak mode was 10 dB lower than the limit specified, then testing could be stopped and the peak values of the EUT would be reported. Otherwise the emissions that did not have 10 dB margin would be re-tested one by one using peak, quasi-peak or average method as specified and then reported in a data sheet.

#### NOTE ;

1. The resolution bandwidth and video bandwidth of test receiver/spectrum analyzer is 120 kHz for Peak detection (PK) or Quasi-peak detection (QP) at frequency below 1 GHz.
2. The resolution bandwidth and video bandwidth of test receiver/spectrum analyzer is 1 MHz for Peak detection and frequency above 1 GHz.
3. The resolution bandwidth of test receiver/spectrum analyzer is 1 MHz and the video bandwidth is 10 Hz for Average detection (AV) at frequency above 1 GHz.

### 2.3.2. Test Procedures for Conducted Spurious Emissions

1. The transmitter output was connected to the spectrum analyzer.
2. The bandwidth of the fundamental frequency was measured with the spectrum analyzer using RBW = 100 kHz, VBW = 100 kHz.

---

*The results shown in this test report refer only to the sample(s) tested unless otherwise stated. This test report cannot be reproduced, except in full, without prior written permission of the Company.*



## 2.4. Test Results

Ambient temperature : (24 ± 2) °C  
 Relative humidity : 47 % R.H.

### 2.4.1. Spurious Radiated Emission (Worst case configuration\_11g mode)

The frequency spectrum from 30 MHz to 1 000 MHz was investigated. Emission levels are not reported much lower than the limits by over 30 dB. All reading values are peak values.

Radiated Emissions			Ant	Correction Factors		Total	FCC Limit	
Frequency (MHz)	Reading (dBμV)	Detect Mode	Pol.	AF (dB/m)	AMP + CL (dB)	Actual (dBμV/m)	Limit (dBμV/m)	Margin (dB)
186.202	54.7	Q.P.	H	9.85	-26.36	38.2	43.5	5.3
239.402	55.4	Q.P.	H	12.07	-25.90	41.6	46.0	4.4
292.607	55.2	Q.P.	H	13.25	-25.67	42.8	46.0	3.2
665.012	46.4	Q.P.	H	19.61	-26.28	39.7	46.0	6.3
799.988	45.6	Q.P.	H	21.07	-25.69	41.0	46.0	5.0
Above 800.000	Not detected	-	-	-	-	-	-	-

#### Remark:

1. All spurious emission at channels are almost the same below 1 GHz, so that the channel was chosen at representative in final test.
2. Actual = Reading + AF + AMP + CL

*The results shown in this test report refer only to the sample(s) tested unless otherwise stated. This test report cannot be reproduced, except in full, without prior written permission of the Company.*

### 2.4.2. Spurious Radiated Emission

The frequency spectrum above 1000 MHz was investigated. Emission levels are not reported much lower than the limits by over 30 dB.

#### DSSS : 802.11b

Low Channel (2 412 MHz)

Radiated Emissions			Ant	Correction Factors		Total	FCC Limit	
Frequency (MHz)	Reading (dB $\mu$ V)	Detect Mode	Pol.	AF (dB/m)	CL (dB)	Actual (dB $\mu$ V/m)	Limit (dB $\mu$ V/m)	Margin (dB)
*2 390.000	25.71	Peak	H	28.09	4.84	58.64	74.00	15.36
*2 390.000	12.27	Average	H	28.09	4.84	45.20	54.00	8.80

Radiated Emissions			Ant	Correction Factors		Total	FCC Limit	
Frequency (MHz)	Reading (dB $\mu$ V)	Detect Mode	Pol.	AF (dB/m)	AMP+CL (dB)	Actual (dB $\mu$ V/m)	Limit (dB $\mu$ V/m)	Margin (dB)
4 819.753	45.37	Peak	H	32.65	-27.79	50.23	74.00	23.77
Above 4 900.000	Not detected	-	-	-	-	-	-	-

Middle Channel (2 437 MHz)

Radiated Emissions			Ant	Correction Factors		Total	FCC Limit	
Frequency (MHz)	Reading (dB $\mu$ V)	Detect Mode	Pol.	AF (dB/m)	AMP+CL (dB)	Actual (dB $\mu$ V/m)	Limit (dB $\mu$ V/m)	Margin (dB)
4 871.596	45.80	Peak	H	32.85	-27.64	51.01	74.00	22.99
Above 4 900.000	Not detected	-	-	-	-	-	-	-

The results shown in this test report refer only to the sample(s) tested unless otherwise stated. This test report cannot be reproduced, except in full, without prior written permission of the Company.

High Channel (2 462 MHz)

Radiated Emissions			Ant	Correction Factors		Total	FCC Limit	
Frequency (MHz)	Reading (dB $\mu$ V)	Detect Mode	Pol.	AF (dB/m)	CL (dB)	Actual (dB $\mu$ V/m)	Limit (dB $\mu$ V/m)	Margin (dB)
*2 483.500	30.18	Peak	H	28.09	4.78	63.05	74.00	10.95
*2 483.500	15.96	Average	H	28.09	4.78	48.83	54.00	5.17

Radiated Emissions			Ant	Correction Factors		Total	FCC Limit	
Frequency (MHz)	Reading (dB $\mu$ V)	Detect Mode	Pol.	AF (dB/m)	AMP+CL (dB)	Actual (dB $\mu$ V/m)	Limit (dB $\mu$ V/m)	Margin (dB)
4 921.115	45.42	Peak	H	33.08	-27.39	51.11	74.00	22.89
Above 5 000.000	Not detected	-	-	-	-	-	-	-

*The results shown in this test report refer only to the sample(s) tested unless otherwise stated. This test report cannot be reproduced, except in full, without prior written permission of the Company.*

**OFDM : 802.11g**

Low Channel (2 412 MHz)

Radiated Emissions			Ant	Correction Factors		Total	FCC Limit	
Frequency (MHz)	Reading (dB $\mu$ V)	Detect Mode	Pol.	AF (dB/m)	CL (dB)	Actual (dB $\mu$ V/m)	Limit (dB $\mu$ V/m)	Margin (dB)
*2 390.000	24.69	Peak	H	28.09	4.84	57.62	74.00	16.38
*2 390.000	12.05	Average	H	28.09	4.84	44.98	54.00	9.02

Radiated Emissions			Ant	Correction Factors		Total	FCC Limit	
Frequency (MHz)	Reading (dB $\mu$ V)	Detect Mode	Pol.	AF (dB/m)	AMP+CL (dB)	Actual (dB $\mu$ V/m)	Limit (dB $\mu$ V/m)	Margin (dB)
4 822.397	44.29	Peak	H	32.66	-27.79	49.16	74.00	24.84
Above 4 900.000	Not detected	-	-	-	-	-	-	-

Middle Channel (2 437 MHz)

Radiated Emissions			Ant	Correction Factors		Total	FCC Limit	
Frequency (MHz)	Reading (dB $\mu$ V)	Detect Mode	Pol.	AF (dB/m)	AMP+CL (dB)	Actual (dB $\mu$ V/m)	Limit (dB $\mu$ V/m)	Margin (dB)
4 875.042	44.91	Peak	H	32.87	-27.61	50.17	74.00	23.83
Above 4 900.000	Not detected	-	-	-	-	-	-	-

The results shown in this test report refer only to the sample(s) tested unless otherwise stated. This test report cannot be reproduced, except in full, without prior written permission of the Company.

High Channel (2 462 MHz)

Radiated Emissions			Ant	Correction Factors		Total	FCC Limit	
Frequency (MHz)	Reading (dB $\mu$ V)	Detect Mode	Pol.	AF (dB/m)	CL (dB)	Actual (dB $\mu$ V/m)	Limit (dB $\mu$ V/m)	Margin (dB)
*2 483.500	34.49	Peak	H	28.09	4.78	67.36	74.00	6.64
*2 483.500	17.44	Average	H	28.09	4.78	50.31	54.00	3.69

Radiated Emissions			Ant	Correction Factors		Total	FCC Limit	
Frequency (MHz)	Reading (dB $\mu$ V)	Detect Mode	Pol.	AF (dB/m)	AMP+CL (dB)	Actual (dB $\mu$ V/m)	Limit (dB $\mu$ V/m)	Margin (dB)
4 921.788	45.56	Peak	H	33.09	-27.39	51.26	74.00	22.74
Above 5 000.000	Not detected	-	-	-	-	-	-	-

Remarks ;

1. “\*” means the restricted band.
2. Measuring frequencies from 1 GHz to the 10<sup>th</sup> harmonic of highest fundamental Frequency.
3. Radiated emissions measured in frequency above 1 000 MHz were made with an instrument using peak/average detector mode.
4. Average test would be performed if the peak result were greater than the average limit.
5. Actual = Reading + AF + AMP + CL

The results shown in this test report refer only to the sample(s) tested unless otherwise stated. This test report cannot be reproduced, except in full, without prior written permission of the Company.

### 2.4.3. Spurious RF Conducted Emissions: Plot of Spurious RF Conducted Emission

DSSS : 802.11b

Low Channel



The results shown in this test report refer only to the sample(s) tested unless otherwise stated. This test report cannot be reproduced, except in full, without prior written permission of the Company.

Middle Channel

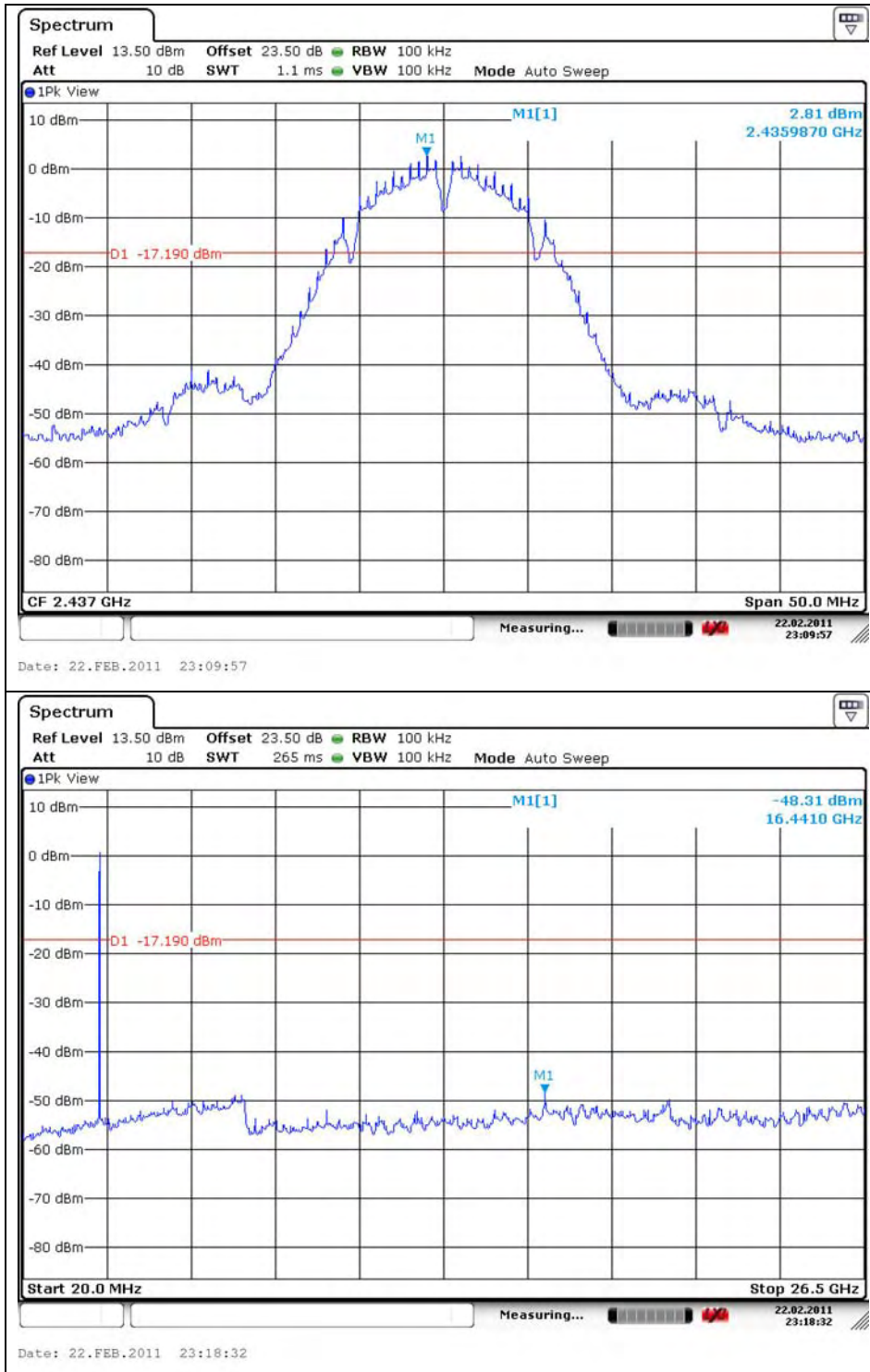

The results shown in this test report refer only to the sample(s) tested unless otherwise stated. This test report cannot be reproduced, except in full, without prior written permission of the Company.

High Channel

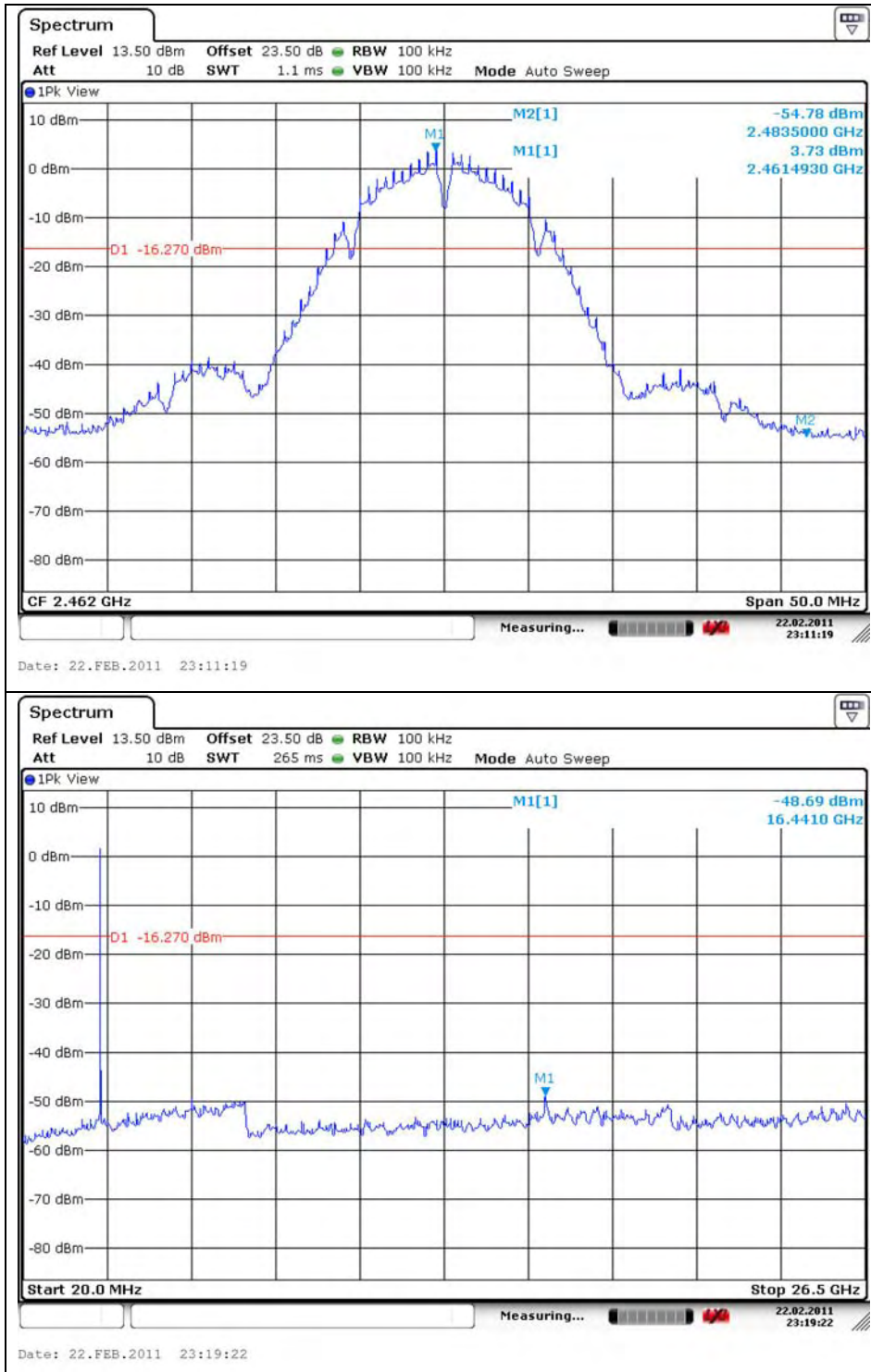

The results shown in this test report refer only to the sample(s) tested unless otherwise stated. This test report cannot be reproduced, except in full, without prior written permission of the Company.



**OFDM : 802.11g**  
Low Channel

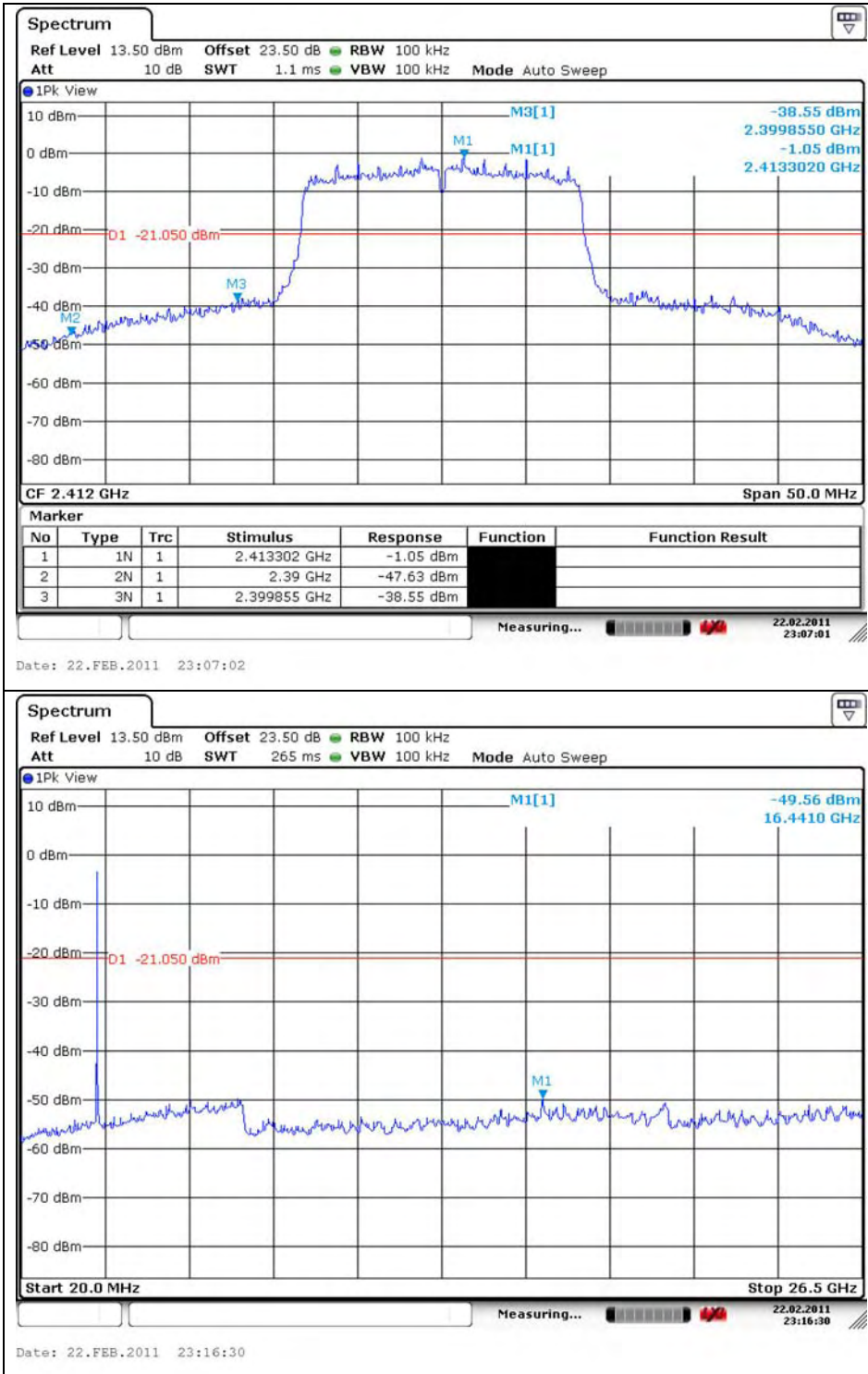

The results shown in this test report refer only to the sample(s) tested unless otherwise stated. This test report cannot be reproduced, except in full, without prior written permission of the Company.

Middle Channel

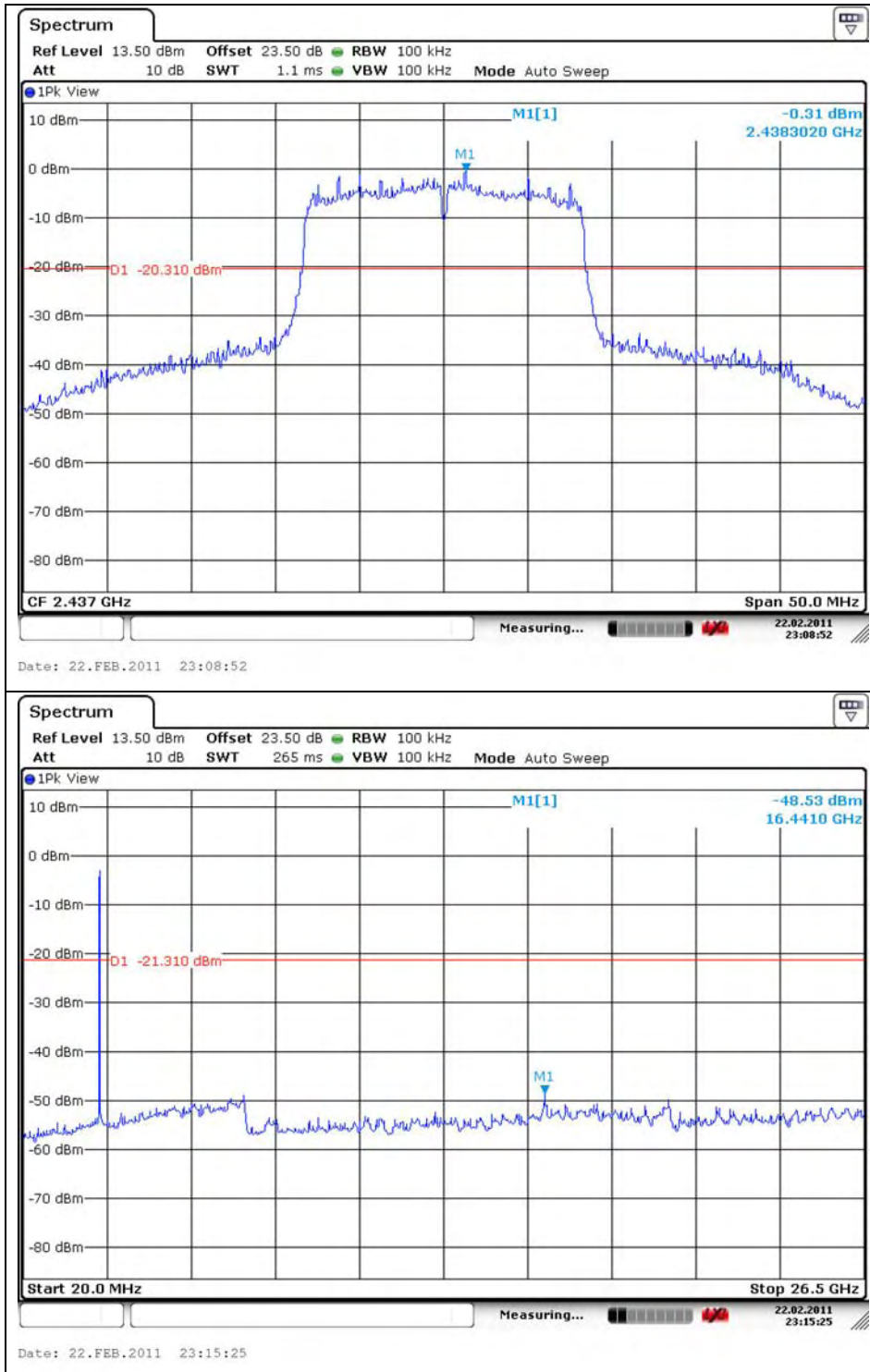

The results shown in this test report refer only to the sample(s) tested unless otherwise stated. This test report cannot be reproduced, except in full, without prior written permission of the Company.

High Channel

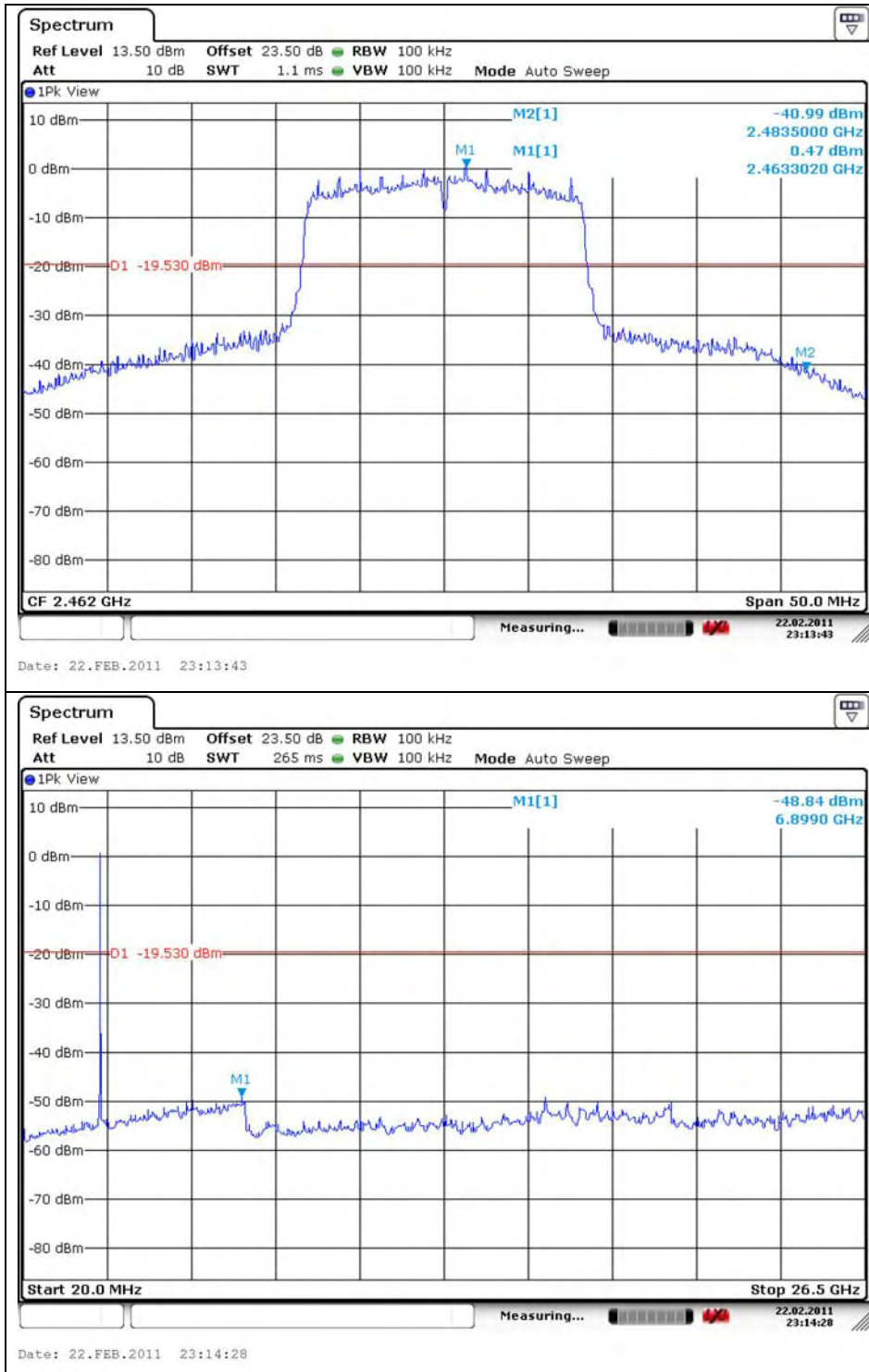

The results shown in this test report refer only to the sample(s) tested unless otherwise stated. This test report cannot be reproduced, except in full, without prior written permission of the Company.

## 3. 6 dB Bandwidth Measurement

### 3.1. Test Setup

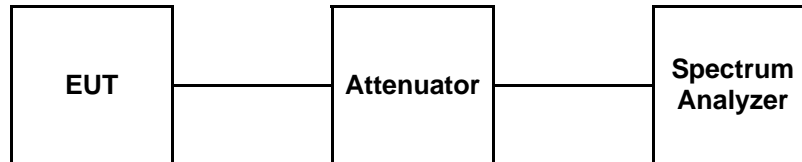

### 3.2. Limit

According to §15.247(a)(2), systems using digital modulation techniques may operate in the 902 ~928 MHz, 2 400 ~ 2 483.5 MHz, and 5 725 ~ 5 825 MHz bands. The minimum of 6 dB Bandwidth shall be at least 500 kHz

### 3.3. Test Procedure

1. The 6 dB band width was measured with a spectrum analyzer connected to RF antenna connector(conducted measurement) while EUT was operating in transmit mode at the appropriate center frequency. The analyzer center frequency was set to the EUT carrier frequency, using the analyzer. Display Line and Marker Delta functions, the 6 dB band width of the emission was determined.
2. The bandwidth of the fundamental frequency was measured with the spectrum analyzer using RBW = 100 kHz, VBW = 100 kHz, Span = 50 MHz.

*The results shown in this test report refer only to the sample(s) tested unless otherwise stated. This test report cannot be reproduced, except in full, without prior written permission of the Company.*

### 3.4. Test Results

Ambient temperature : (24 ± 2) °C  
 Relative humidity : 47 % R.H.

Operation Mode	Channel	Channel Frequency (MHz)	6 dB Bandwidth (MHz)	Minimum Limit (MHz)
DSSS (802.11b)	Low	2 412	8.03	0.5
	Middle	2 437	8.03	
	High	2 462	8.03	
OFDM (802.11g)	Low	2 412	15.12	
	Middle	2 437	15.60	
	High	2 462	15.31	

*The results shown in this test report refer only to the sample(s) tested unless otherwise stated. This test report cannot be reproduced, except in full, without prior written permission of the Company.*

**DSSS : 802.11b**

Low Channel

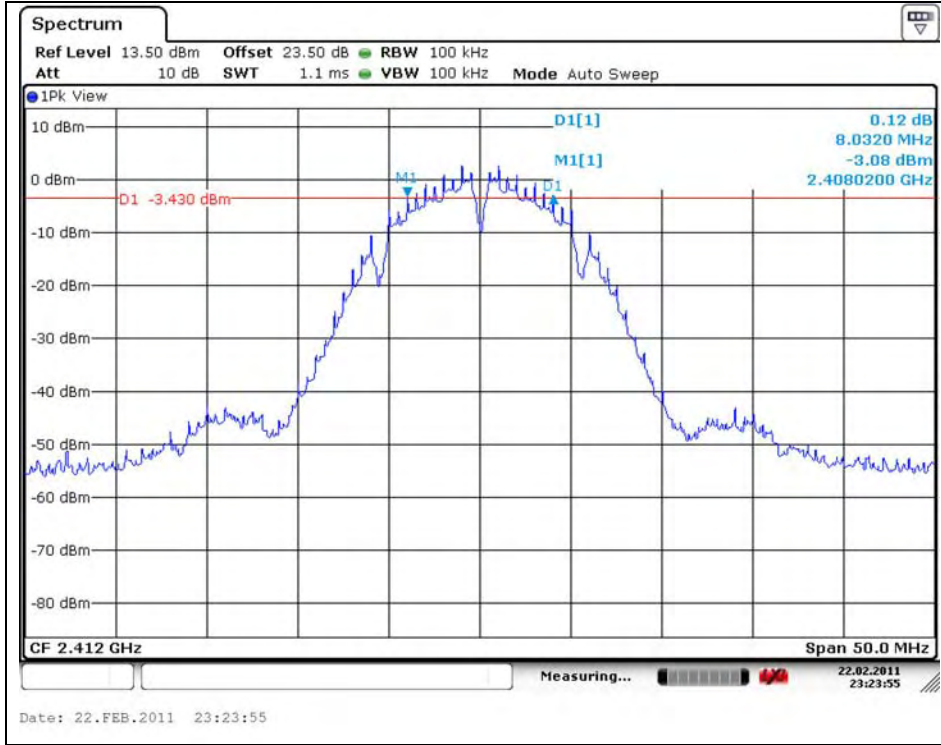

Middle Channel

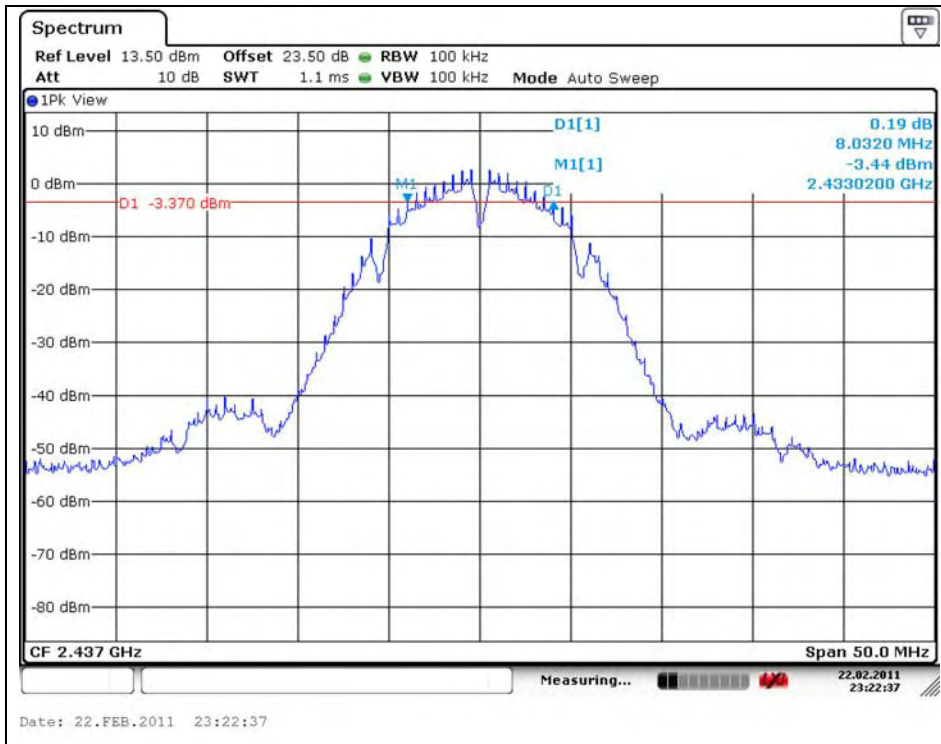

The results shown in this test report refer only to the sample(s) tested unless otherwise stated. This test report cannot be reproduced, except in full, without prior written permission of the Company.

High Channel

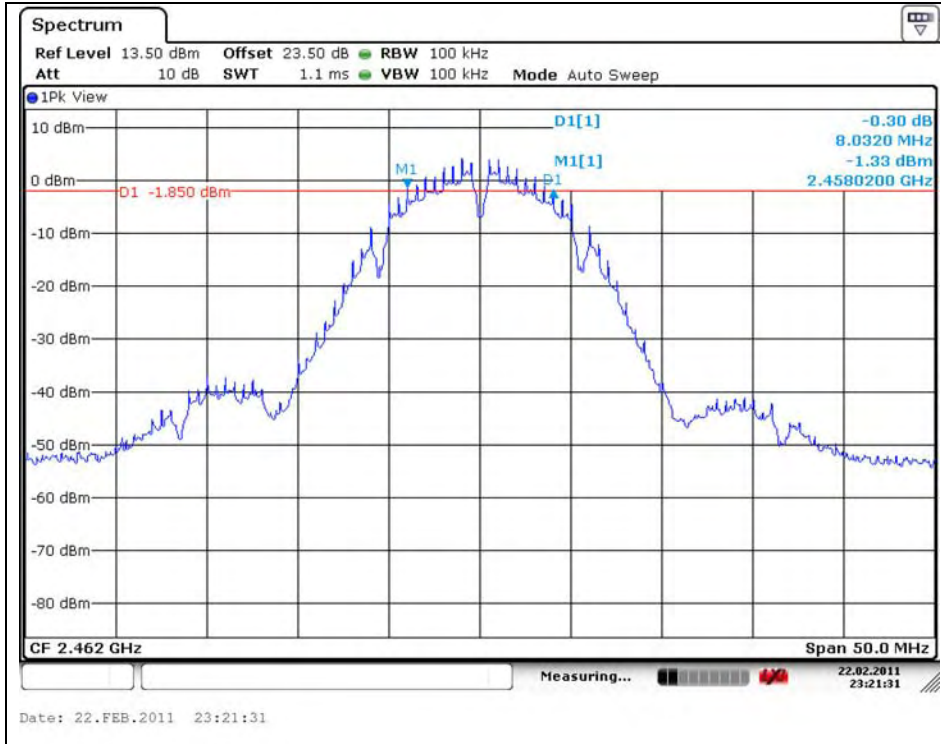

OFDM : 802.11g

Low Channel

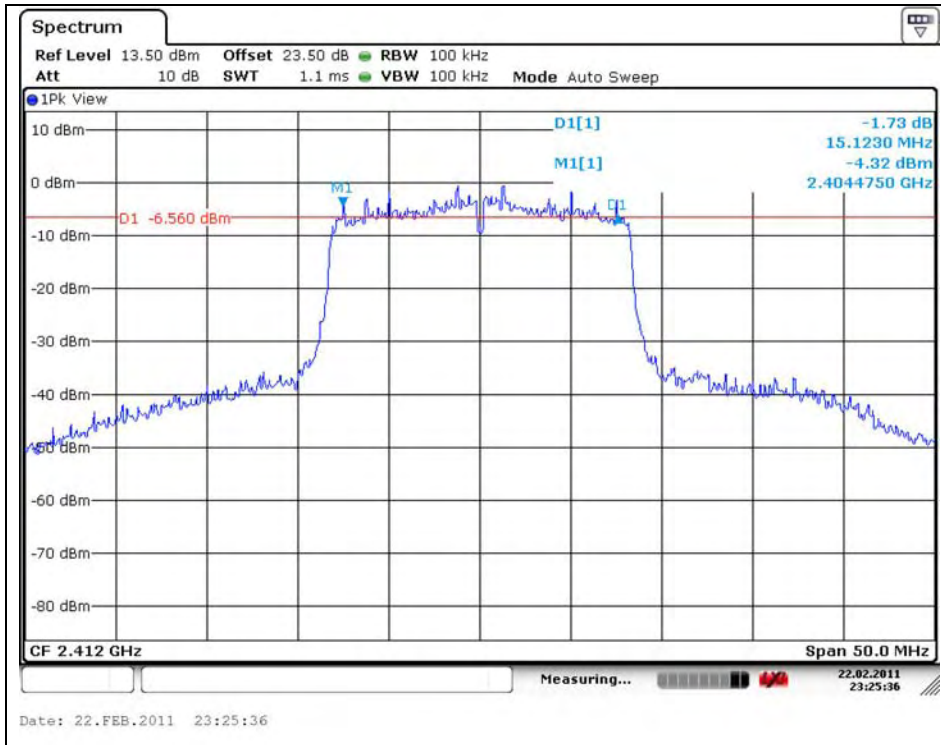

The results shown in this test report refer only to the sample(s) tested unless otherwise stated. This test report cannot be reproduced, except in full, without prior written permission of the Company.

Middle Channel

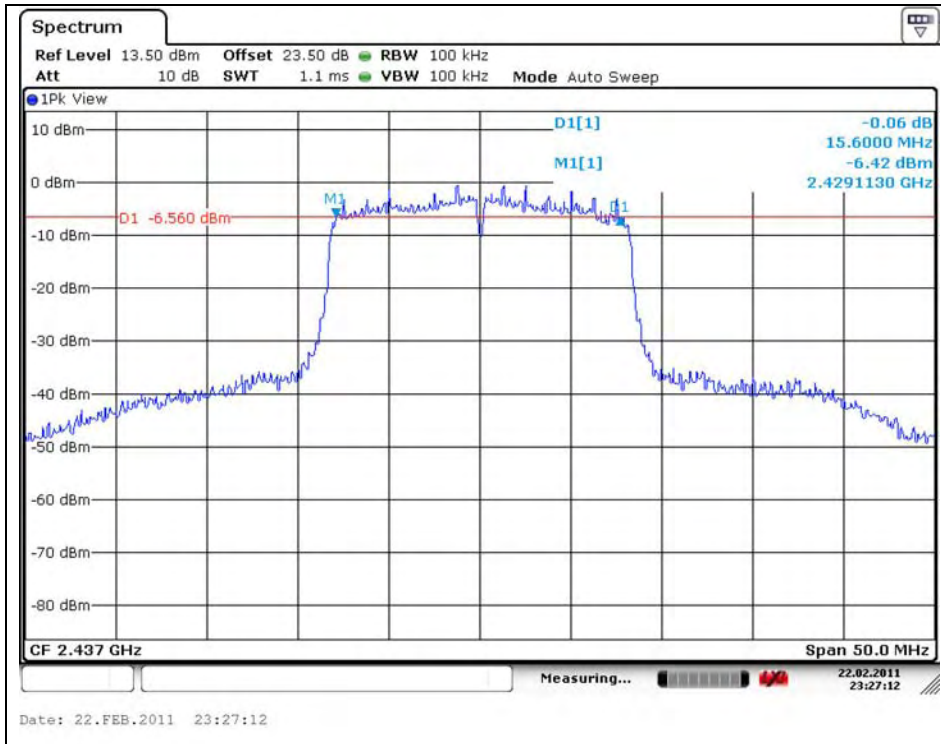

High Channel

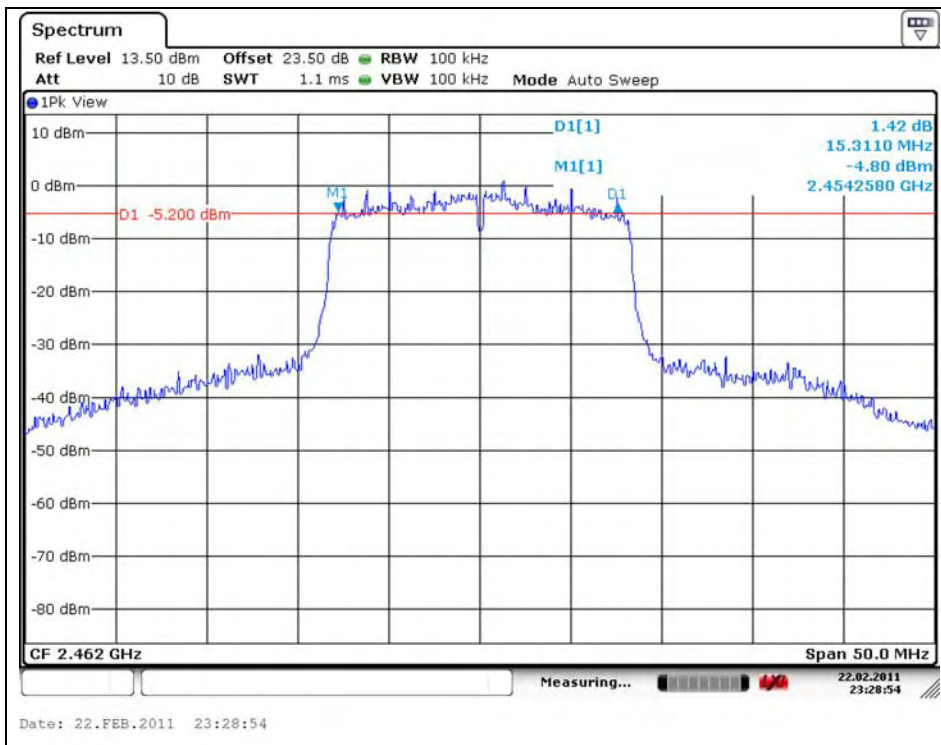

The results shown in this test report refer only to the sample(s) tested unless otherwise stated. This test report cannot be reproduced, except in full, without prior written permission of the Company.



## 4. Maximum Peak Output Power Measurement

### 4.1. Test Setup

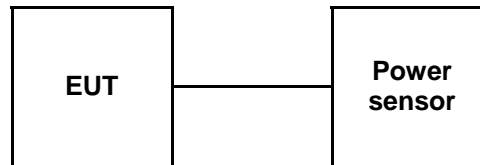

### 4.2. Limit

According to §15.247(b)(3), for systems using digital modulation in the 902 ~ 928 MHz, 2 400 ~2 483.5 MHz, and 5 725 ~ 5 850 MHz band: 1 Watt. As an alternative to a peak power measurement, compliance with the one watt limit can be based on a measurement of the maximum conducted output power. Maximum Conducted output Power is defined as the total transmit power delivered to all antennas and antenna elements averaged across all symbols in the signaling alphabet when the transmitter is operating at its maximum power control level. Power must be summed across all antenna elements. The average must not include any intervals during which the transmitter is off or is transmitting at a reduced power level. If multiple modes of operation are possible (e.g., alternative modulation methods), the maximum conducted output power is the highest total transmit power occurring in any mode.

According to §15.247(b)(4), the conducted output power limit specified in paragraph(b) of this section is based on the use of antenna with directional gains that do not exceed 6 dBi. Except as shown in paragraph(c) of this section, if transmitting antenna of directional gain greater than 6 dBi are used, the conducted output power from the intentional radiator shall be reduced below the stated values in paragraph (b)(1), (b)(2), and (b)(3) of this section , as appropriate, by the amount in dB that the directional gain of the antenna exceeds 6dBi.

### 4.3. Test Procedure

1. Place the EUT on the table and set it in the transmitting mode.
2. Remove the antenna from the EUT and then connect a low loss RF cable from the antenna port to power sensor

*The results shown in this test report refer only to the sample(s) tested unless otherwise stated. This test report cannot be reproduced, except in full, without prior written permission of the Company.*

#### 4.4. Test Results

Ambient temperature : (24 ± 2) °C  
 Relative humidity : 47 % R.H.

Operation Mode	Channel	Channel Frequency (MHz)	Peak Power Output (dB m)	Peak Power Limit (dB m)
DSSS (802.11b)	Low	2 412	13.64	30
	Middle	2 437	14.14	30
	High	2 462	14.87	30
OFDM (802.11g)	Low	2 412	21.49	30
	Middle	2 437	21.96	30
	High	2 462	22.04	30

*The results shown in this test report refer only to the sample(s) tested unless otherwise stated. This test report cannot be reproduced, except in full, without prior written permission of the Company.*

---

## 5. POWER SPECTRAL DENSITY MEASUREMENT

### 5.1. Test Setup

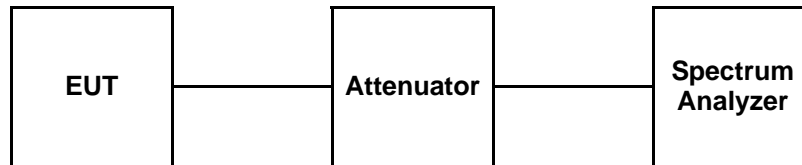

### 5.2. Limit

§15.247(e) For digitally modulated system, the power spectral density conducted from the intentional radiator to the antenna shall not be greater than 8 dB m in any 3 kHz band any time interval of continuous transmission. This power spectral density shall be determined in accordance with the provisions of paragraph (b) of this section. The same method of determining the conducted output power shall be used to determine the power spectral density.

### 5.3. Test Procedure

1. Check the calibration of the measuring instrument using either an internal calibrator or a known signal from an external generator.
2. Position the EUT as shown in test setup without connection to measurement instrument. Turn on the EUT and connect it to measurement instrument. Then set it to any one convenient frequency within its operating range.
3. By using the Max Hold function record the separation of adjacent channels.
4. Repeat above procedures until all frequencies measured were complete.
5. The bandwidth of the fundamental frequency was measured with the spectrum analyzer using ;  
RBW = 3 kHz, VBW = 10 kHz, Span = 300 kHz and Sweep = 100 s.

---

*The results shown in this test report refer only to the sample(s) tested unless otherwise stated. This test report cannot be reproduced, except in full, without prior written permission of the Company.*

## 5.4. Test Results

Ambient temperature : (24 ± 2) °C  
 Relative humidity : 47 % R.H.

Operation Mode	Frequency	Final RF Power Level in 3 kHz BW (dB m)	Maximum Limit (dB m)
DSSS (802.11b)	2 412 MHz	-10.39	8
	2 437 MHz	-9.37	8
	2 462 MHz	-8.63	8
OFDM (802.11g)	2 412 MHz	-14.43	8
	2 437 MHz	-13.54	8
	2 462 MHz	-13.48	8

*The results shown in this test report refer only to the sample(s) tested unless otherwise stated. This test report cannot be reproduced, except in full, without prior written permission of the Company.*

**DSSS : 802.11b**

Low Channel

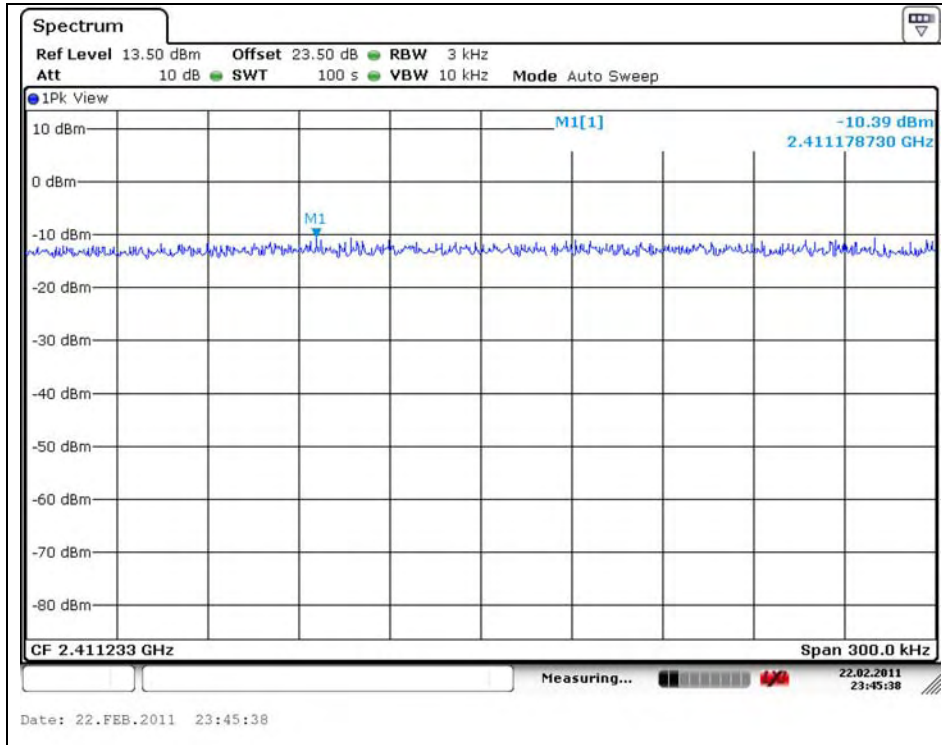

Middle Channel

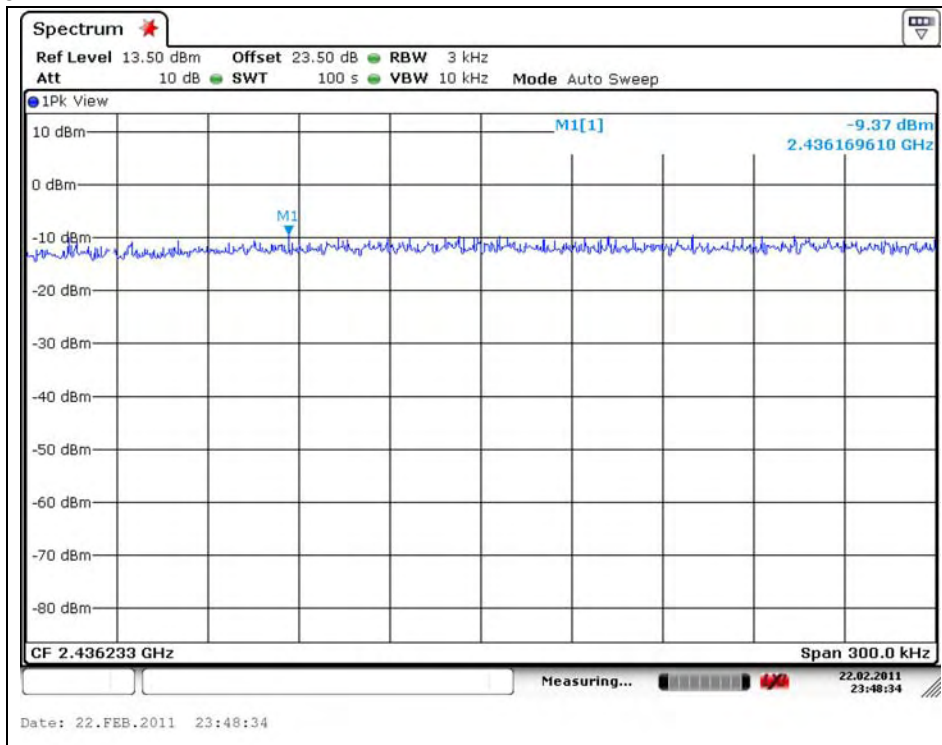

The results shown in this test report refer only to the sample(s) tested unless otherwise stated. This test report cannot be reproduced, except in full, without prior written permission of the Company.

High Channel

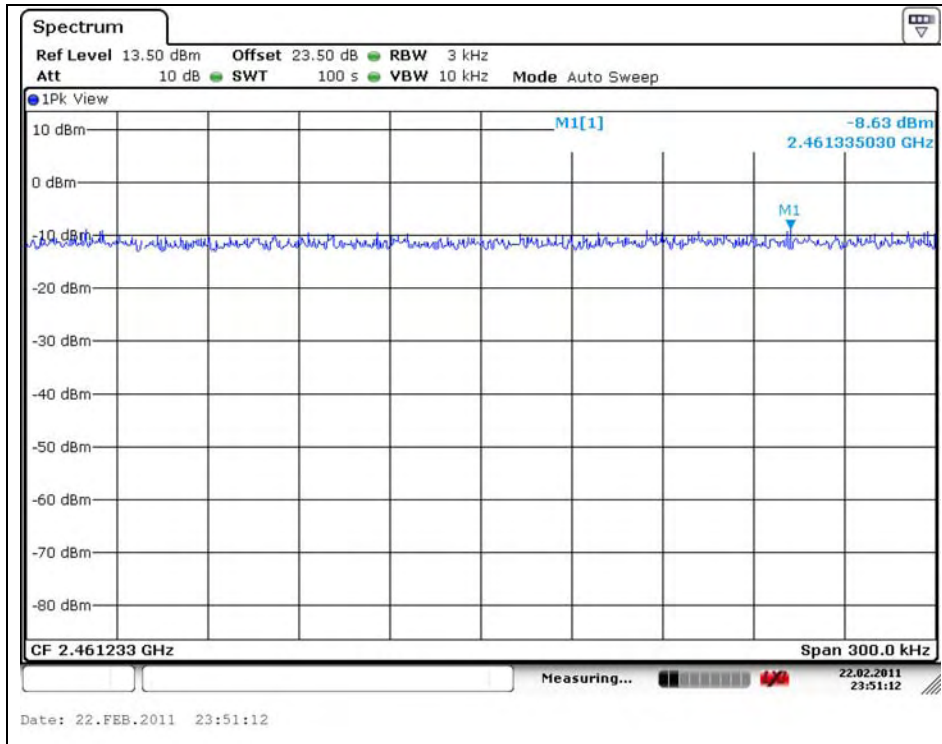

OFDM : 802.11g

Low Channel

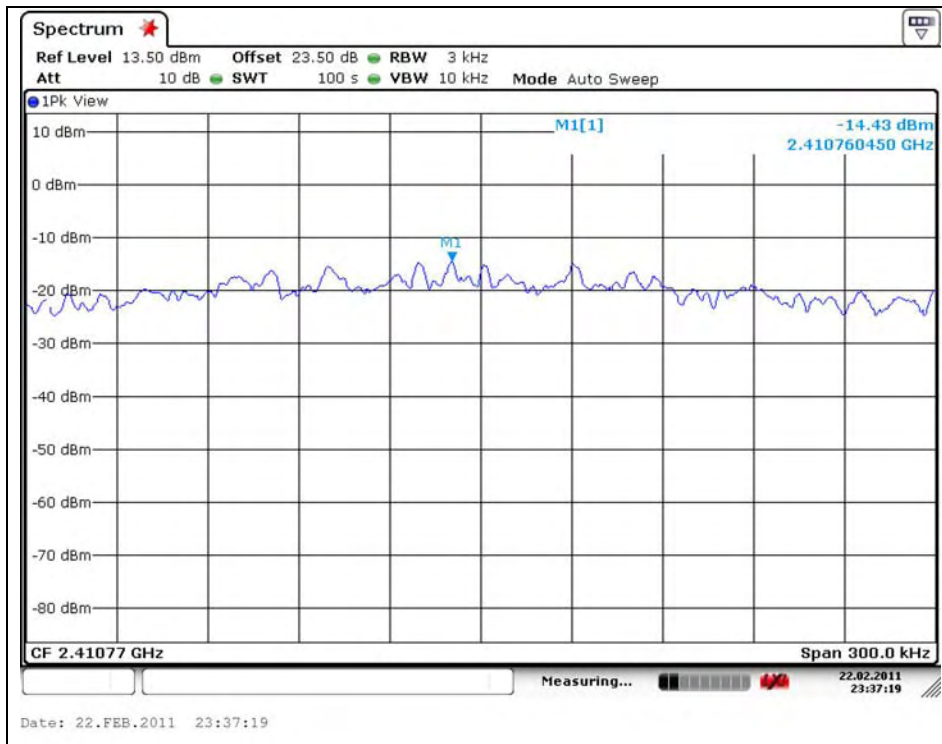

The results shown in this test report refer only to the sample(s) tested unless otherwise stated. This test report cannot be reproduced, except in full, without prior written permission of the Company.

Middle Channel

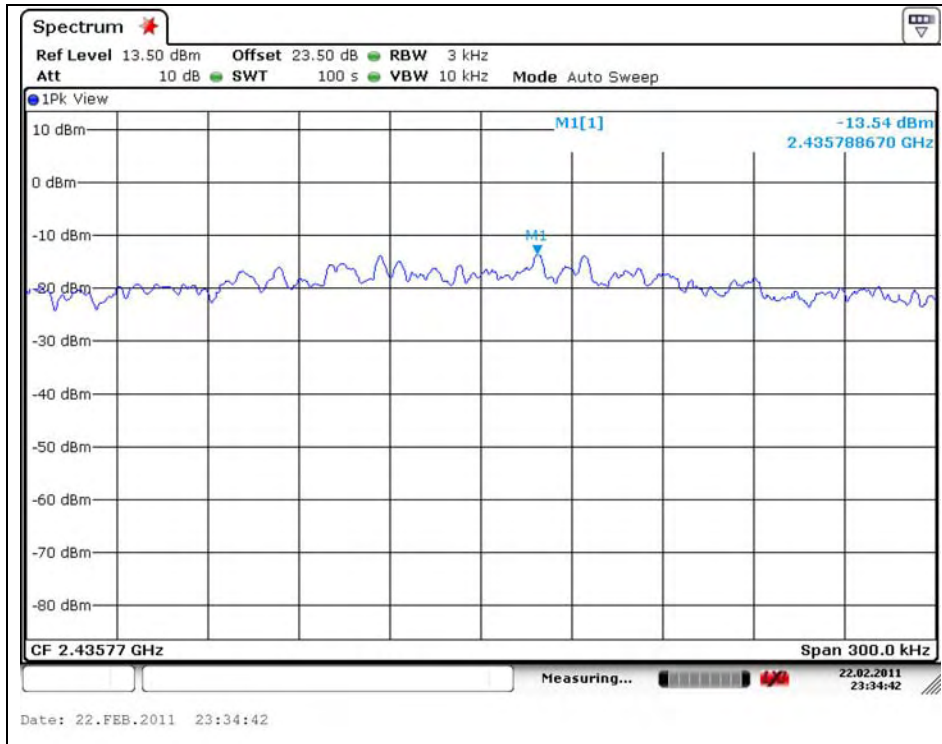

High Channel

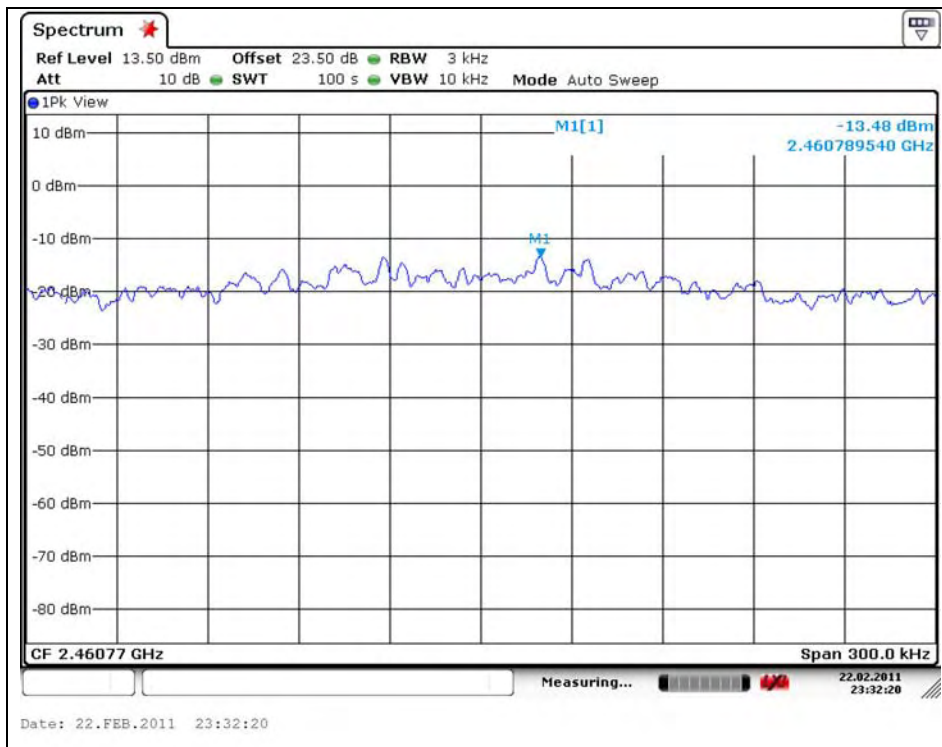

The results shown in this test report refer only to the sample(s) tested unless otherwise stated. This test report cannot be reproduced, except in full, without prior written permission of the Company.

## 6. Transmitter AC Power Line Conducted Emission

### 6.1. Test Setup

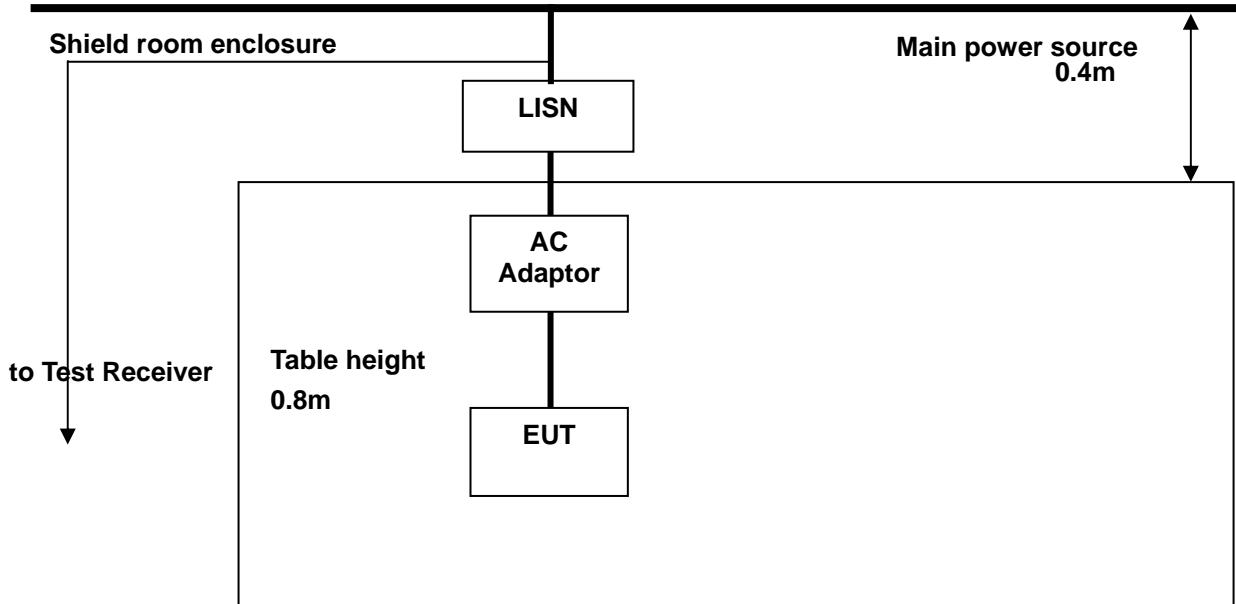

### 6.2. Limit

According to §15.207(a) for an intentional radiator that is designed to be connected to the public utility (AC) power line, the radio frequency voltage that is conducted back onto the AC power line on any frequency or frequencies, within the band 150 kHz to 30 MHz, shall not exceed the limits in the following table, as measured using a 50 uH/50 ohm line impedance stabilization network(LISN).

Compliance with the provision of this paragraph shall on the measurement of the radio frequency voltage between each power line and ground at the power terminal. The lower applies at the boundary between the frequency ranges.

Frequency of Emission (MHz)	Conducted limit (dB $\mu$ V)	
	Quasi-peak	Average
0.15 – 0.50	66 - 56*	56 - 46*
0.50 – 5.00	56	46
5.00 – 30.0	60	50

\* Decreases with the logarithm of the frequency.

The results shown in this test report refer only to the sample(s) tested unless otherwise stated. This test report cannot be reproduced, except in full, without prior written permission of the Company.



### 6.3. Test Procedures

Radiated emissions from the EUT were measured according to the dictates of ANSI C63.4:2003

1. The test procedure is performed in a 6.5m × 3.6m × 3.6m (L × W × H) shielded room. The EUT along with its peripherals were placed on a 1.0 m(W) × 1.5 m(L) and 0.8 m in height wooden table and the EUT was adjusted to maintain a 0.4 meter space from a vertical reference plane.
2. The EUT was connected to power mains through a line impedance stabilization network (LISN) which provides 50 ohm coupling impedance for measuring instrument and the chassis ground was bounded to the horizontal ground plane of shielded room.
3. All peripherals were connected to the second LISN and the chassis ground also bounded to the horizontal ground plane of shielded room.
4. The excess power cable between the EUT and the LISN was bundled. The power cables of peripherals were unbundled. All connecting cables of EUT and peripherals were moved to find the maximum emission.

---

*The results shown in this test report refer only to the sample(s) tested unless otherwise stated. This test report cannot be reproduced, except in full, without prior written permission of the Company.*

#### 6.4. Test Results (Worst case configuration\_11g mode)

The following table shows the highest levels of conducted emissions on both phase of Hot and Neutral line.

Ambient temperature : (24 ± 2) °C  
 Relative humidity : 47 % R.H.

Frequency range : 0.15 MHz – 30 MHz

Measured Bandwidth : 9 kHz

FREQ. (MHz)	LEVEL(dB $\mu$ V)		LINE	LIMIT(dB $\mu$ V)		MARGIN(dB)	
	Q-Peak	Average		Q-Peak	Average	Q-Peak	Average
0.16	63.2	34.1	H	65.5	55.5	2.3	21.4
0.19	52.1	33.3	H	64.3	54.3	12.2	21.0
0.31	45.1	32.0	H	60.0	50.0	14.9	18.0
5.83	30.4	21.9	H	60.0	50.0	29.6	28.1
15.52	17.3	13.7	H	60.0	50.0	42.7	36.3
26.60	22.5	19.8	H	60.0	50.0	37.5	30.2
0.16	51.3	26.9	N	65.5	55.5	14.2	28.6
0.18	51.7	32.8	N	64.7	54.7	13.0	21.9
0.33	44.1	40.1	N	59.6	49.6	15.5	9.5
0.56	38.5	33.9	N	56.0	46.0	17.5	12.1
0.84	36.9	31.9	N	56.0	46.0	19.1	14.1
5.85	31.4	24.5	N	60.0	50.0	28.6	25.5

Note ;

Line ( H ) : Hot

Line ( N ) : Neutral

*The results shown in this test report refer only to the sample(s) tested unless otherwise stated. This test report cannot be reproduced, except in full, without prior written permission of the Company.*

**Plot of Conducted Power line**

Test mode : (Hot)

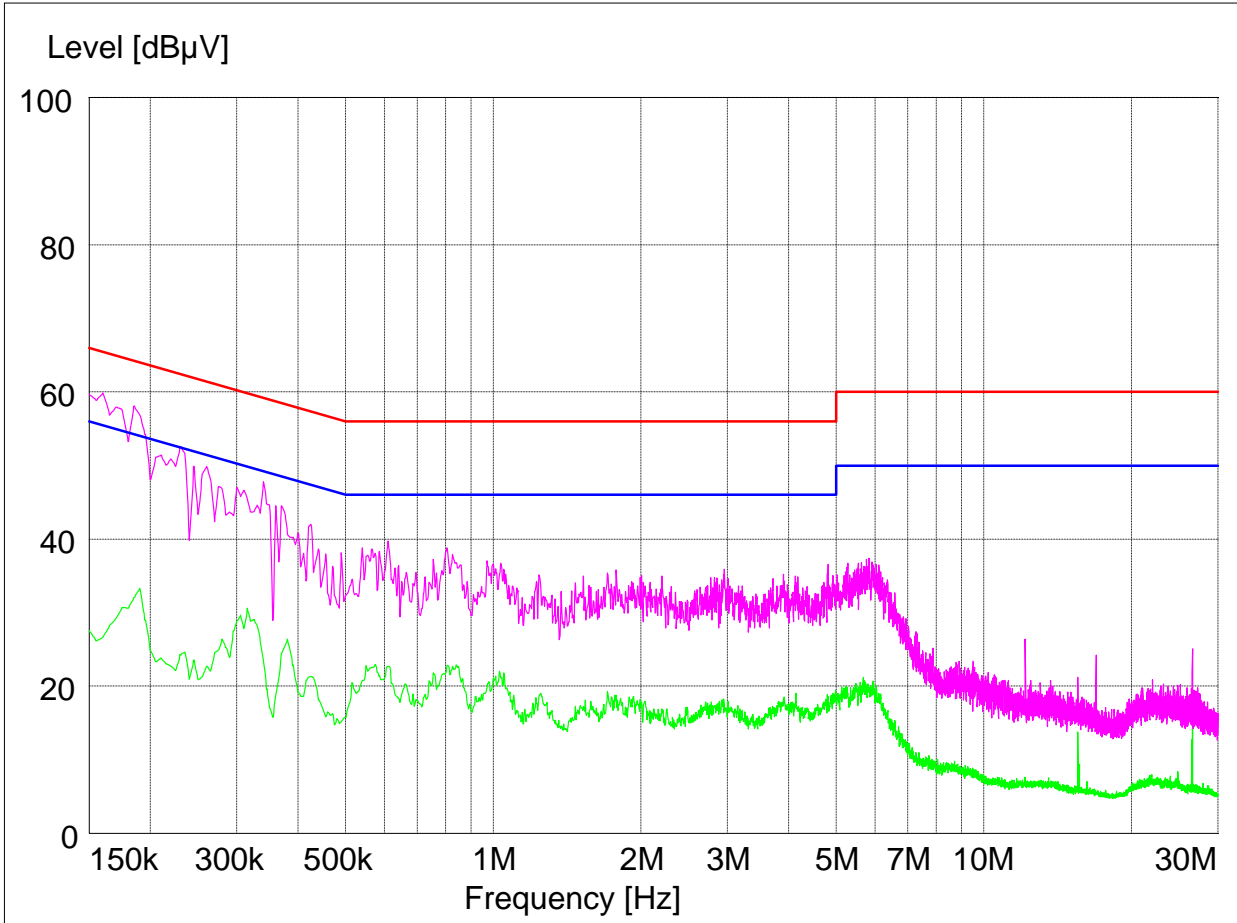

*The results shown in this test report refer only to the sample(s) tested unless otherwise stated. This test report cannot be reproduced, except in full, without prior written permission of the Company.*

Test mode : (Neutral)

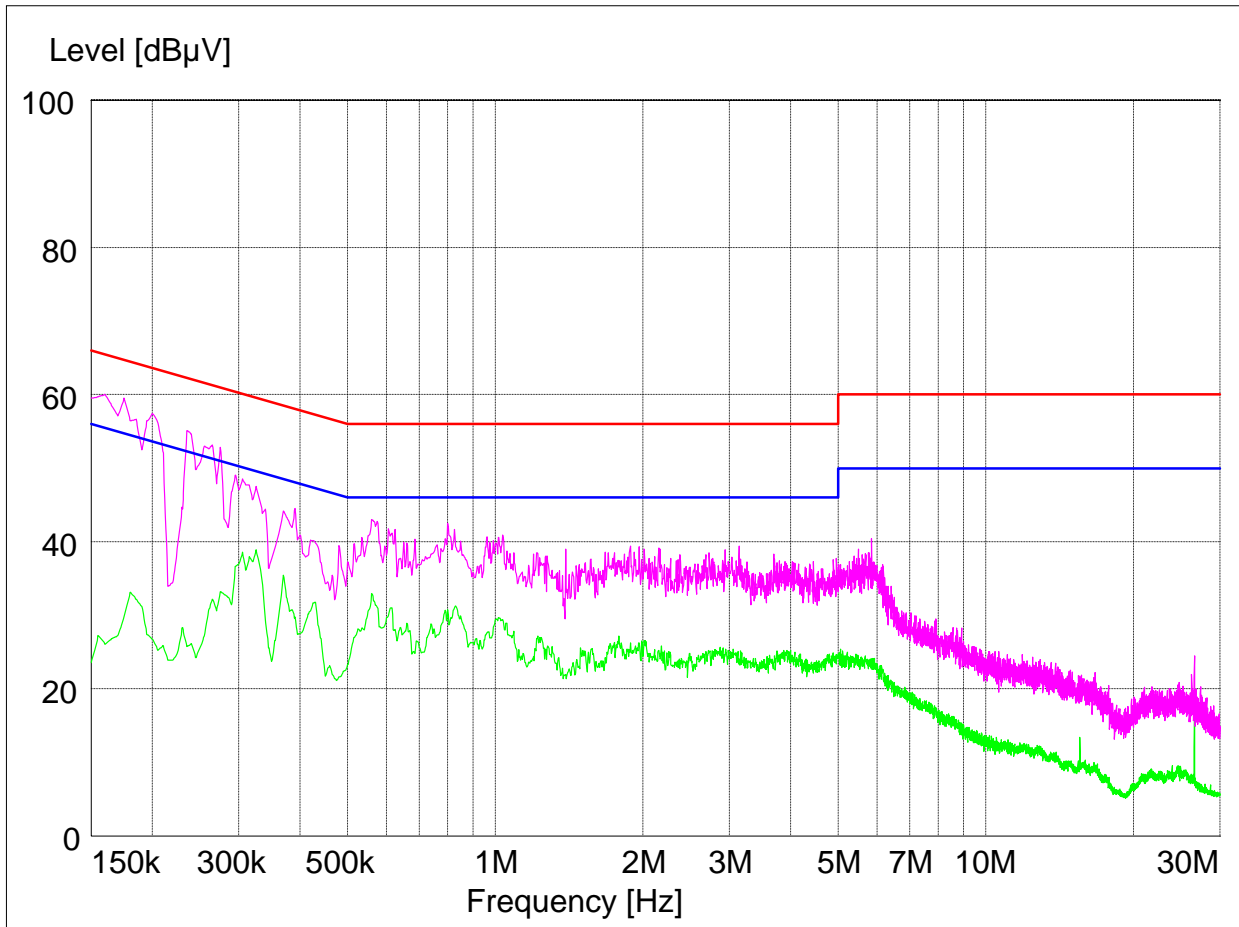

The results shown in this test report refer only to the sample(s) tested unless otherwise stated. This test report cannot be reproduced, except in full, without prior written permission of the Company.

## 7. Antenna Requirement

### 7.1. Standard Applicable

For intentional device, according to FCC 47 CFR Section §15.203, an intentional radiator shall be designed to ensure that no antenna other than that furnished by the responsible party shall be used with the device. And according to FCC 47 CFR Section §15.247 (b) if transmitting antennas of directional gain greater than 6 dB i are used, the power shall be reduced by the amount in dB that the gain of the antenna exceeds 6 dB i.

### 7.2. Antenna Connected Construction

Antenna used in this product is Integral type (Chip Antenna ) gain of 1.7 dB i.

---

*The results shown in this test report refer only to the sample(s) tested unless otherwise stated. This test report cannot be reproduced, except in full, without prior written permission of the Company.*

## 8. RF Exposure Evaluation

### 8.1 Environmental evaluation and exposure limit according to FCC CFR 47 part 1, 1.1307(b), 1.1310

According to FCC 1.1310 : The criteria listed in the following table shall be used to evaluate the environment impact of human exposure to radio frequency (RF) radiation as specified in §1.1307(b)

#### LIMITS FOR MAXIMUM PERMISSIBLE EXPOSURE (MPE)

Frequency Range (MHz)	Electric Field Strength(V/m)	Magnetic Field Strength (A/m)	Power Density (mW/cm <sup>2</sup> )	Average Time
(A) Limits for Occupational /Control Exposures				
300 – 1 500	--	--	F/300	6
1 500 – 100 000	--	--	5	6
(B) Limits for General Population/Uncontrol Exposures				
300 – 1 500	--	--	F/1500	6
<b><u>1 500 – 100 000</u></b>	--	--	<b><u>1</u></b>	<b><u>30</u></b>

#### 8.1.1. Friis transmission formula: $P_d = (P_{out} \cdot G) / (4 \cdot \pi \cdot R^2)$

Where  $P_d$  = power density in mW/cm<sup>2</sup>

$P_{out}$  = output power to antenna in mW

G = gain of antenna in linear scale

$\pi$  = 3.1416

R = distance between observation point and center of the radiator in cm

$P_d$  the limit of MPE, 1 mW/cm<sup>2</sup>. If we know the maximum gain of the antenna and the total power input to the antenna, through the calculation, we will know the distance where the MPE limit is reached.

*The results shown in this test report refer only to the sample(s) tested unless otherwise stated. This test report cannot be reproduced, except in full, without prior written permission of the Company.*

### 8.1.2. Test Result of RF Exposure Evaluation

Test Item : RF Exposure Evaluation Data

Test Mode : Normal Operation

### 8.1.3. Output Power into Antenna & RF Exposure Evaluation Distance

FHSS : 11b

Channel	Channel Frequency (MHz)	Output Average Power to Antenna (dB m)	Antenna Gain (dB i)	Power Density at 20 cm (mW/cm <sup>2</sup> )	LIMITS (mW/cm <sup>2</sup> )
Low	2 412	9.86	1.7	0.002 85	1
Middle	2 437	10.59	1.7	0.003 20	1
High	2 462	11.42	1.7	0.003 88	1

FHSS : 11g

Channel	Channel Frequency (MHz)	Output Average Power to Antenna (dB m)	Antenna Gain (dB i)	Power Density at 20 cm (mW/cm <sup>2</sup> )	LIMITS (mW/cm <sup>2</sup> )
Low	2 412	9.52	1.7	0.002 63	1
Middle	2 437	10.12	1.7	0.003 03	1
High	2 462	10.65	1.7	0.003 42	1

Note :

1. The power density Pd (5th column) at a distance of 20 cm calculated from the friis transmission formula is far below the limit of 1 mW/cm<sup>2</sup> .

*The results shown in this test report refer only to the sample(s) tested unless otherwise stated. This test report cannot be reproduced, except in full, without prior written permission of the Company.*