



# FCC TEST REPORT

**REPORT NO.:** RF961203L09

**MODEL NO.:** MZK-W04NU

**RECEIVED:** Dec. 03, 2007

**TESTED:** Dec. 14, 2007 ~ Jan. 08, 2008

**ISSUED:** Jan. 11, 2008

**APPLICANT:** PLANEX COMMUNICATION INC.

**ADDRESS:** 9F-1, No. 188, Baociao Rd., Sindian City, Taipei  
County 231, TAIWAN

**ISSUED BY:** Advance Data Technology Corporation

**LAB ADDRESS:** 47 14<sup>th</sup> Lin, Chiapau Tsun, Linko, Taipei, Taiwan,  
R.O.C.

**TEST LOCATION:** No. 19, Hwa Ya 2<sup>nd</sup> Rd., Kueishan, Taoyuan,  
Taiwan, R.O.C.

This test report consists of 91 pages in total. It may be duplicated completely for legal use with the approval of the applicant. It should not be reproduced except in full, without the written approval of our laboratory. The client should not use it to claim product endorsement by TAF, A2LA or any government agencies. The test results in the report only apply to the tested sample.





## TABLE OF CONTENTS

1.	CERTIFICATION.....	4
2.	SUMMARY OF TEST RESULTS .....	5
2.1	MEASUREMENT UNCERTAINTY.....	5
3.	GENERAL INFORMATION.....	6
3.1	GENERAL DESCRIPTION OF EUT .....	6
3.2	DESCRIPTION OF TEST MODES .....	7
3.2.1	CONFIGURATION OF SYSTEM UNDER TEST .....	8
3.2.2	TEST MODE APPLICABILITY AND TESTED CHANNEL DETAIL.....	9
3.3	GENERAL DESCRIPTION OF APPLIED STANDARDS.....	11
3.4	DESCRIPTION OF SUPPORT UNITS.....	11
4.	TEST TYPES AND RESULTS .....	12
4.1	RADIATED EMISSION MEASUREMENT .....	12
4.1.1	LIMITS OF RADIATED EMISSION MEASUREMENT.....	12
4.1.2	TEST INSTRUMENTS .....	13
4.1.3	TEST PROCEDURES .....	14
4.1.4	DEVIATION FROM TEST STANDARD .....	14
4.1.5	TEST SETUP .....	15
4.1.6	EUT OPERATING CONDITIONS .....	15
4.1.7	TEST RESULTS .....	16
4.2	CONDUCTED EMISSION MEASUREMENT .....	29
4.2.1	LIMITS OF CONDUCTED EMISSION MEASUREMENT.....	29
4.2.2	TEST INSTRUMENTS .....	29
4.2.3	TEST PROCEDURES .....	30
4.2.4	DEVIATION FROM TEST STANDARD .....	30
4.2.5	TEST SETUP .....	31
4.2.6	EUT OPERATING CONDITIONS .....	31
4.2.7	TEST RESULTS .....	32
4.3	6dB BANDWIDTH MEASUREMENT .....	34
4.3.1	LIMITS OF 6dB BANDWIDTH MEASUREMENT .....	34
4.3.2	TEST INSTRUMENTS .....	34
4.3.3	TEST PROCEDURE .....	34
4.3.4	DEVIATION FROM TEST STANDARD .....	34
4.3.5	TEST SETUP .....	35
4.3.6	EUT OPERATING CONDITIONS .....	35
4.3.7	TEST RESULTS .....	36
4.4	MAXIMUM PEAK OUTPUT POWER.....	50
4.4.1	LIMITS OF MAXIMUM PEAK OUTPUT POWER MEASUREMENT .....	50
4.4.2	INSTRUMENTS.....	50
4.4.3	TEST PROCEDURES .....	50
4.4.4	DEVIATION FROM TEST STANDARD .....	50
4.4.5	TEST SETUP .....	51
4.4.6	EUT OPERATING CONDITIONS .....	51
4.4.7	TEST RESULTS .....	52
4.5	POWER SPECTRAL DENSITY MEASUREMENT .....	54
4.5.1	LIMITS OF POWER SPECTRAL DENSITY MEASUREMENT .....	54
4.5.2	TEST INSTRUMENTS .....	54
4.5.3	TEST PROCEDURE .....	54
4.5.4	DEVIATION FROM TEST STANDARD .....	54
4.5.5	TEST SETUP .....	55
4.5.6	EUT OPERATING CONDITION .....	55



4.5.7	TEST RESULTS .....	56
4.6	BAND EDGES MEASUREMENT .....	70
4.6.1	LIMITS OF BAND EDGES MEASUREMENT .....	70
4.6.2	TEST INSTRUMENTS .....	70
4.6.3	TEST PROCEDURE .....	71
4.6.4	DEVIATION FROM TEST STANDARD .....	71
4.6.5	EUT OPERATING CONDITION .....	71
4.6.6	TEST RESULTS .....	72
4.7	ANTENNA REQUIREMENT .....	88
4.7.1	STANDARD APPLICABLE .....	88
4.7.2	ANTENNA CONNECTED CONSTRUCTION .....	88
5.	PHOTOGRAPHS OF THE TEST CONFIGURATION .....	89
6.	INFORMATION ON THE TESTING LABORATORIES .....	90
7.	APPENDIX A - MODIFICATIONS RECORDERS FOR ENGINEERING CHANGES TO THE EUT BY THE LAB.....	91



# 1. CERTIFICATION

**PRODUCT :** 11N WIRELESS LAN USB ROUTER  
**MODEL NO.:** MZK-W04NU  
**BRAND:** PCI  
**APPLICANT :** PLANEX COMMUNICATION INC.  
**TESTED:** Dec. 14, 2007 ~ Jan. 08, 2008  
**TEST SAMPLE:** ENGINEERING SAMPLE  
**STANDARDS :** **FCC Part 15, Subpart C (Section 15.247)**  
ANSI C63.4-2003

The above equipment (Model: MZK-W04NU) has been tested by **Advance Data Technology Corporation**, and found compliance with the requirement of the above standards. The test record, data evaluation & Equipment Under Test (EUT) configurations represented herein are true and accurate accounts of the measurements of the sample's EMC characteristics under the conditions specified in this report.

**PREPARED BY :** Peggy Chen , **DATE:** Jan. 11, 2008  
Peggy Chen / Specialist

**TECHNICAL ACCEPTANCE :** Long Chen , **DATE:** Jan. 11, 2008  
Responsible for RF Long Chen / Senior Engineer

**APPROVED BY :** Gary Chang , **DATE:** Jan. 11, 2008  
Gary Chang / Assistant Manager

## 2. SUMMARY OF TEST RESULTS

The EUT has been tested according to the following specifications:

APPLIED STANDARD: FCC Part 15, Subpart C			
STANDARD SECTION	TEST TYPE AND LIMIT	RESULT	REMARK
15.207	AC Power Conducted Emission	PASS	Meet the requirement of limit. Minimum passing margin is -16.72dB at 0.197MHz.
15.247(a)(2)	Spectrum Bandwidth of a Direct Sequence Spread Spectrum System Limit : min. 500kHz	PASS	Meet the requirement of limit.
15.247(b)	Maximum Peak Output Power Limit: max. 30dBm	PASS	Meet the requirement of limit.
15.247(d)	Transmitter Radiated Emissions Limit: Table 15.209	PASS	Meet the requirement of limit. Minimum passing margin is -1.12dB at 7386.0MHz.
15.247(e)	Power Spectral Density Limit: max. 8dBm	PASS	Meet the requirement of limit.
15.247(d)	Band Edge Measurement Limit: 20dB less than the peak value of fundamental frequency	PASS	Meet the requirement of limit.

### 2.1 MEASUREMENT UNCERTAINTY

Where relevant, the following measurement uncertainty levels have been estimated for tests performed on the EUT as specified in CISPR 16-4-2:

MEASUREMENT	FREQUENCY	UNCERTAINTY
Conducted emissions	9kHz ~ 30MHz	2.44 dB
Radiated emissions	30MHz ~ 200MHz	2.93 dB
	200MHz ~ 1000MHz	2.95 dB
	1GHz ~ 18GHz	2.26 dB
	18GHz ~ 40GHz	1.94 dB

This uncertainty represents an expanded uncertainty expressed at approximately the 95% confidence level using a coverage factor of  $k = 2$ .

### 3. GENERAL INFORMATION

#### 3.1 GENERAL DESCRIPTION OF EUT

<b>PRODUCT</b>	11N WIRELESS LAN USB ROUTER
<b>MODEL NO.</b>	MZK-W04NU
<b>FCC ID</b>	SJ9-MZKW04NU
<b>POWER SUPPLY</b>	5Vdc from AC Adapter
<b>MODULATION TYPE</b>	CCK, DQPSK, DBPSK for DSSS 64QAM, 16QAM, QPSK, BPSK for OFDM
<b>MODULATION TECHNOLOGY</b>	DSSS, OFDM
<b>TRANSFER RATE</b>	802.11b: 11.0/ 5.5/ 2.0/ 1.0Mbps 802.11g: 54.0/ 48.0/ 36.0/ 24.0/ 18.0/ 12.0/ 9.0/ 6.0Mbps Draft 802.11n: up to 300Mbps
<b>FREQUENCY RANGE</b>	2412MHz ~ 2462MHz
<b>NUMBER OF CHANNEL</b>	11 for 802.11b, 802.11g, draft 802.11n (20MHz) 7 for draft 802.11n (40MHz)
<b>MAXIMUM OUTPUT POWER</b>	76.821mW
<b>ANTENNA TYPE</b>	Dipole antenna with 3dBi gain
<b>DATA CABLE</b>	NA
<b>I/O PORTS</b>	RJ45
<b>ACCESSORY DEVICES</b>	Adapter

**NOTE:**

- The EUT were operated with following power adapter:

<b>BRAND:</b>	JENTEC TECHNOLOGY CO., LTD.
<b>MODEL:</b>	AF 1805-A
<b>INPUT:</b>	100-120Vac, 50-60Hz, 0.4A
<b>OUTPUT:</b>	5Vdc, 3A
<b>POWER LINE:</b>	1.8m non-shielded cable without core

- The EUT incorporates a MIMO function. Physically, the card provides three completed transmitters and three receivers.
- The EUT is 3 \* 3 spatial MIMO (3Tx & 3Rx) without beam forming function that only operate triple chain configuration (both chain 0, chain 1 and chain 2 transceivers are operational).
- When the EUT operating in 802.11b & 802.11g is for single Tx.
- When the EUT operating in draft 802.11n, the software operation, which is defined by manufacturer, only set 0 ~ 15 of "MCS" (MCS: Modulation and Coding Schemes) for triple Tx.
- The EUT complies with draft 802.11n standards and backwards compatible with 802.11b, 802.11g products.
- The EUT operates in the 2.4GHz frequency spectrum with throughput of up to 300Mbps.
- The above EUT information was declared by manufacturer and for more detailed features description, please refer to the manufacturer's specifications or user's manual.

### 3.2 DESCRIPTION OF TEST MODES

Eleven channels are provided for 802.11b, 802.11g, draft 802.11n (20MHz):

CHANNEL	FREQUENCY	CHANNEL	FREQUENCY
1	2412MHz	7	2442MHz
2	2417MHz	8	2447MHz
3	2422MHz	9	2452MHz
4	2427MHz	10	2457MHz
5	2432MHz	11	2462MHz
6	2437MHz		

Seven channels are provided for draft 802.11n (40MHz):

CHANNEL	FREQUENCY	CHANNEL	FREQUENCY
1	2422MHz	5	2442MHz
2	2427MHz	6	2447MHz
3	2432MHz	7	2452MHz
4	2437MHz		

### 3.2.1 CONFIGURATION OF SYSTEM UNDER TEST

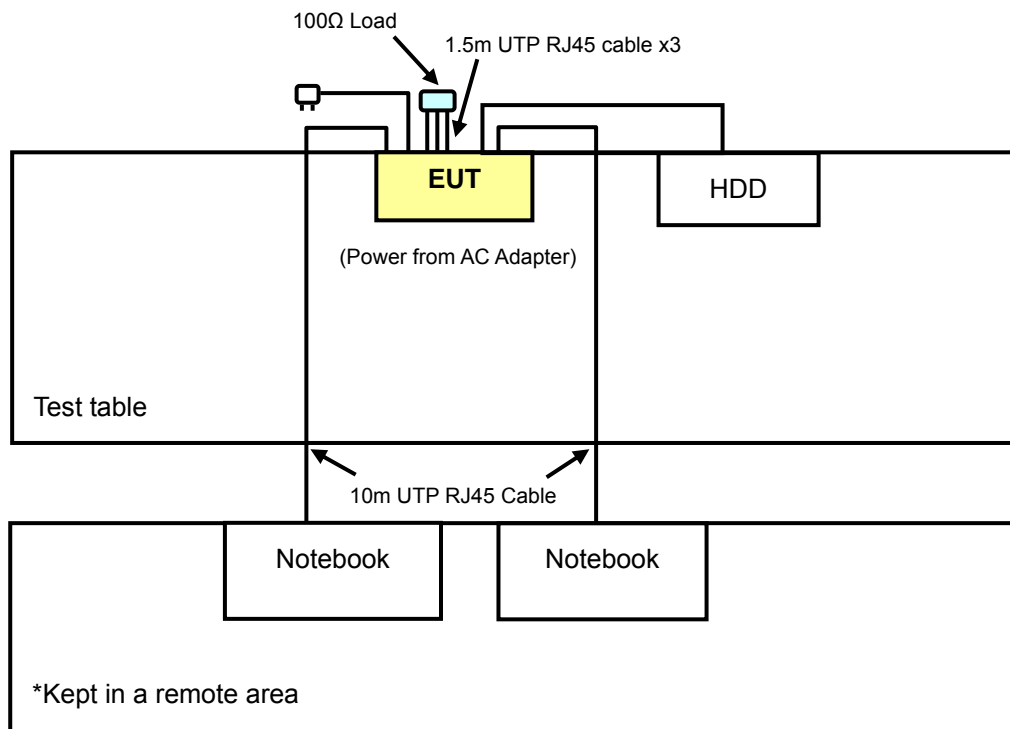



### 3.2.2 TEST MODE APPLICABILITY AND TESTED CHANNEL DETAIL

EUT CONFIGURE MODE	APPLICABLE TO					DESCRIPTION
	RE ≥ 1G	RE < 1G	PLC	BANDEDGE	APCM	
-	√	√	√	√	√	-

Where **RE ≥ 1G**: Radiated Emission above 1GHz

**RE < 1G**: Radiated Emission below 1GHz

**PLC**: Power Line Conducted Emission

**APCM**: Antenna Port Conducted Measurement

#### RADIATED EMISSION TEST (ABOVE 1 GHz):

- Pre-Scan has been conducted to determine the worst-case mode from all possible combinations between available modulations, data rates and antenna ports (if EUT with antenna diversity architecture).
- Following channel(s) was (were) selected for the final test as listed below.

MODE	AVAILABLE CHANNEL	TESTED CHANNEL	MODULATION TECHNOLOGY	MODULATION TYPE	DATA RATE (Mbps)
802.11b	1 to 11	1, 6, 11	DSSS	DBPSK	1.0
802.11g	1 to 11	1, 6, 11	OFDM	BPSK	6.0
Draft 802.11n (20MHz)	1 to 11	1, 6, 11	OFDM	BPSK	7.2
Draft 802.11n (40MHz)	1 to 7	1, 4, 7	OFDM	BPSK	15.0

#### RADIATED EMISSION TEST (BELOW 1 GHz):

- Pre-Scan has been conducted to determine the worst-case mode from all possible combinations between available modulations, data rates and antenna ports (if EUT with antenna diversity architecture).
- Following channel(s) was (were) selected for the final test as listed below.

MODE	AVAILABLE CHANNEL	TESTED CHANNEL	MODULATION TECHNOLOGY	MODULATION TYPE	DATA RATE (Mbps)
Draft 802.11n (20MHz)	1 to 11	1	OFDM	BPSK	7.2

**POWER LINE CONDUCTED EMISSION TEST:**

- Pre-Scan has been conducted to determine the worst-case mode from all possible combinations between available modulations, data rates and antenna ports (if EUT with antenna diversity architecture).
- Following channel(s) was (were) selected for the final test as listed below.

MODE	AVAILABLE CHANNEL	TESTED CHANNEL	MODULATION TECHNOLOGY	MODULATION TYPE	DATA RATE (Mbps)
Draft 802.11n (20MHz)	1 to 11	1	OFDM	BPSK	7.2

**BANDEDGE MEASUREMENT:**

- Pre-Scan has been conducted to determine the worst-case mode from all possible combinations between available modulations, data rates and antenna ports (if EUT with antenna diversity architecture).
- Following channel(s) was (were) selected for the final test as listed below.

MODE	AVAILABLE CHANNEL	TESTED CHANNEL	MODULATION TECHNOLOGY	MODULATION TYPE	DATA RATE (Mbps)
802.11b	1 to 11	1, 11	DSSS	DBPSK	1.0
802.11g	1 to 11	1, 11	OFDM	BPSK	6.0
Draft 802.11n (20MHz)	1 to 11	1, 11	OFDM	BPSK	7.2
Draft 802.11n (40MHz)	1 to 7	1, 7	OFDM	BPSK	15.0

**ANTENNA PORT CONDUCTED MEASUREMENT:**

- Pre-Scan has been conducted to determine the worst-case mode from all possible combinations between available modulations, data rates and antenna ports (if EUT with antenna diversity architecture).
- Following channel(s) was (were) selected for the final test as listed below.

MODE	AVAILABLE CHANNEL	TESTED CHANNEL	MODULATION TECHNOLOGY	MODULATION TYPE	DATA RATE (Mbps)
802.11b	1 to 11	1, 6, 11	DSSS	DBPSK	1.0
802.11g	1 to 11	1, 6, 11	OFDM	BPSK	6.0
Draft 802.11n (20MHz)	1 to 11	1, 6, 11	OFDM	BPSK	7.2
Draft 802.11n (40MHz)	1 to 7	1, 4, 7	OFDM	BPSK	15.0



### 3.3 GENERAL DESCRIPTION OF APPLIED STANDARDS

The EUT is a RF product. According to the specifications of the manufacturer, it must comply with the requirements of the following standards:

#### FCC Part 15, Subpart C. (15.247)

#### ANSI C63.4-2003

All test items have been performed and recorded as per the above standards.

**NOTE:** The EUT is also considered as a kind of computer peripheral, because the connection to computer is necessary for typical use. It has been verified to comply with the requirements of FCC Part 15, Subpart B, Class B (DoC). The test report has been issued separately.

### 3.4 DESCRIPTION OF SUPPORT UNITS

The EUT has been tested as an independent unit together with other necessary accessories or support units. The following support units or accessories were used to form a representative test configuration during the tests.

NO.	PRODUCT	BRAND	MODEL NO.	SERIAL NO.	FCC ID
1	External Hard Disk	Terasys	F12-UF	A0100222-4A71007	FCC DoC Approved
2	Notebook computer	DELL	PP05L	16484462992	E2K24CLNS
3	Notebook computer	DELL	PP05L	12130898320	E2K24CLNS

NO.	SIGNAL CABLE DESCRIPTION OF THE ABOVE SUPPORT UNITS
1	1.5 m shielded cable, terminated with USB connector, w/o core.
2	10m UTP RJ45 Cable
3	10m UTP RJ45 Cable

**NOTE:**

1. All power cords of the above support units are non-shielded (1.8m).
2. Item 2, 3 acted as communication partners to transfer data.

## 4. TEST TYPES AND RESULTS

### 4.1 RADIATED EMISSION MEASUREMENT

#### 4.1.1 LIMITS OF RADIATED EMISSION MEASUREMENT

Emissions radiated outside of the specified bands, shall be according to the general radiated limits in 15.209 as following:

FREQUENCIES (MHz)	FIELD STRENGTH (microvolts/meter)	MEASUREMENT DISTANCE (meters)
0.009 ~ 0.490	2400 / F(kHz)	300
0.490 ~ 1.705	24000 / F(kHz)	30
1.705 ~ 30.0	30	30
30 ~ 88	100	3
88 ~ 216	150	3
216 ~ 960	200	3
Above 960	500	3

**NOTE:**

1. The lower limit shall apply at the transition frequencies.
2. Emission level (dBuV/m) = 20 log Emission level (uV/m).
3. As shown in 15.35(b), for frequencies above 1000MHz, the field strength limits are based on average detector, however, the peak field strength of any emission shall not exceed the maximum permitted average limits, specified above by more than 20dB under any condition of modulation.



#### 4.1.2 TEST INSTRUMENTS

DESCRIPTION & MANUFACTURER	MODEL NO.	SERIAL NO.	CALIBRATED UNTIL
Test Receiver ROHDE & SCHWARZ	ESCI	100424	Jul. 27, 2008
Spectrum Analyzer ROHDE & SCHWARZ	FSP40	100269	Aug. 05, 2008
BILOG Antenna SCHWARZBECK	VULB9168	9168-153	Jan. 03, 2009
HORN Antenna SCHWARZBECK	BBHA 9120 D	9120D-563	Jul. 30, 2008
HORN Antenna SCHWARZBECK	BBHA 9170	BBHA9170242	Jan. 16, 2008
Preamplifier Agilent	8449B	3008A01910	Sep. 19, 2008
Preamplifier Agilent	8447D	2944A10638	Dec. 19, 2008
RF signal cable HUBER+SUHNNER	SUCOFLEX 104	274039/223650	Nov. 07, 2008
RF signal cable Worken	8D-FB	Cable-HYCH9-01	Aug. 09, 2008
Software	ADT_Radiated_V7.6	NA	NA
Antenna Tower EMCO	2070/2080	512.835.4684	NA
Turn Table EMCO	2087-2.03	NA	NA
Antenna Tower & Turn Table Controller EMCO	2090	NA	NA

- NOTE:**
1. The calibration interval of the above test instruments is 12 months and the calibrations are traceable to NML/ROC and NIST/USA.
  2. The test was performed in HwaYa Chamber 9.
  3. The horn antenna and HP preamplifier (model: 8449B) are used only for the measurement of emission frequency above 1GHz if tested.
  4. The IC Site Registration No. is IC3789B-9.

#### 4.1.3 TEST PROCEDURES

- a. The EUT was placed on the top of a rotating table 0.8 meters above the ground at a 3 meters semi-anechoic chamber. The table was rotated 360 degrees to determine the position of the highest radiation.
- b. The EUT was set 3 meters away from the interference-receiving antenna, which was mounted on the top of a variable-height antenna tower.
- c. The antenna is a broadband antenna, and its height is varied from one meter to four meters above the ground to determine the maximum value of the field strength. Both horizontal and vertical polarizations of the antenna are set to make the measurement.
- d. For each suspected emission, the EUT was arranged to its worst case and then the antenna was tuned to heights from 1 meter to 4 meters and the rotatable table was turned from 0 degrees to 360 degrees to find the maximum reading.
- e. The test-receiver system was set to Peak Detect Function and Specified Bandwidth with Maximum Hold Mode.
- f. If the emission level of the EUT in peak mode was lower than the limit specified, then testing could be stopped and the peak values of the EUT would be reported. Otherwise the emissions would be re-tested one by one using peak, quasi-peak or average method as specified and then reported in a data sheet.

**NOTE:**

1. The resolution bandwidth and video bandwidth of test receiver/spectrum analyzer is 120kHz for Peak detection (PK) and Quasi-peak detection (QP) at frequency below 1GHz.
2. The resolution bandwidth of test receiver/spectrum analyzer is 1 MHz and video bandwidth is 3MHz for Peak detection at frequency above 1GHz.
3. The resolution bandwidth of test receiver/spectrum analyzer is 1MHz and the video bandwidth is 10Hz (for 802.11b/g), 1kHz (for 802.11n) for Average detection (AV) at frequency above 1GHz.

#### 4.1.4 DEVIATION FROM TEST STANDARD

No deviation

#### 4.1.5 TEST SETUP

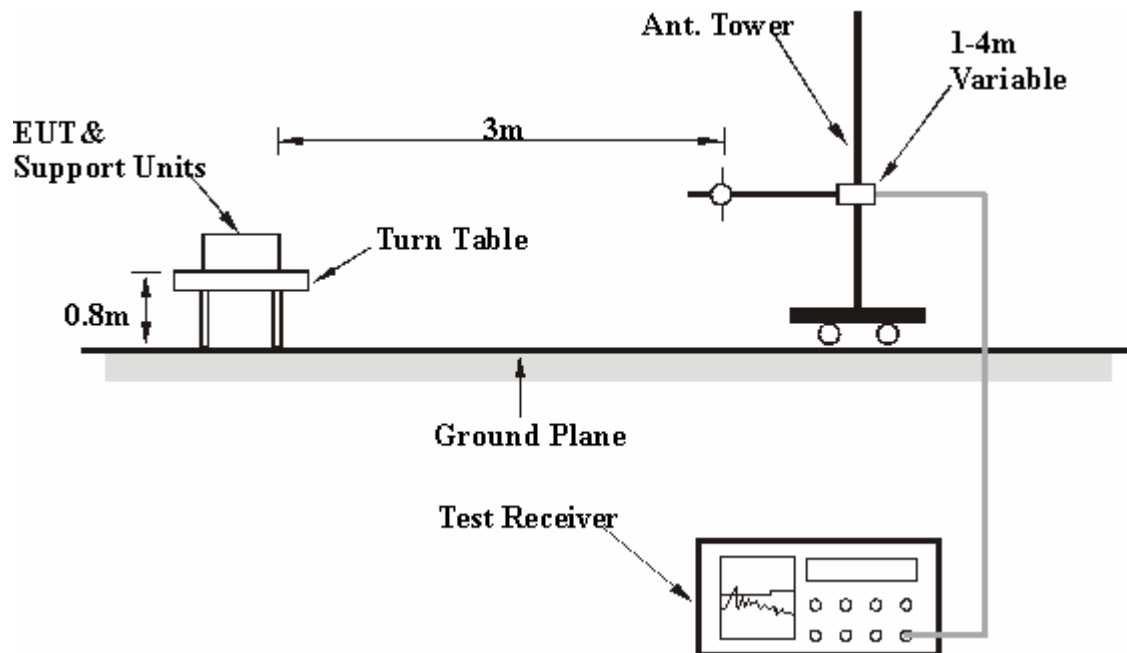

For the actual test configuration, please refer to the related item – Photographs of the Test Configuration.

#### 4.1.6 EUT OPERATING CONDITIONS

- Placed the EUT on a testing table.
- Prepared notebook computers and placed them outside of testing area to act as communication partners for EUT via RJ45 cables.
- The notebook systems ran a test program (provided by manufacturer) to enable EUT under transmission condition continuously at specific channel frequency.

#### 4.1.7 TEST RESULTS

##### 802.11b DSSS MODULATION

EUT TEST CONDITION		MEASUREMENT DETAIL	
CHANNEL	Channel 1	FREQUENCY RANGE	1 ~ 25GHz
INPUT POWER	120Vac, 60 Hz	DETECTOR FUNCTION	Peak (PK) Average (AV)
ENVIRONMENTAL CONDITIONS	24deg. C, 64%RH 1020hPa	TESTED BY	Brad Wu

ANTENNA POLARITY & TEST DISTANCE: HORIZONTAL AT 3 M								
NO.	FREQ. (MHz)	EMISSION LEVEL (dBuV/m)	LIMIT (dBuV/m)	MARGIN (dB)	ANTENNA HEIGHT (m)	TABLE ANGLE (Degree)	RAW VALUE (dBuV)	CORRECTION FACTOR (dB/m)
1	2390.00	56.62 PK	74.00	-17.38	1.03 H	228	24.30	32.32
2	2390.00	45.32 AV	54.00	-8.68	1.03 H	228	13.00	32.32
3	*2412.00	97.25 PK			1.03 H	228	64.93	32.32
4	*2412.00	92.76 AV			1.03 H	228	60.44	32.32
5	4824.00	47.08 PK	74.00	-26.92	1.06 H	227	9.08	38.00
6	4824.00	39.35 AV	54.00	-14.65	1.06 H	227	1.35	38.00
7	7236.00	61.41 PK	77.25	-15.84	1.20 H	51	16.53	44.88
8	7236.00	55.09 AV	72.76	-17.67	1.20 H	51	10.21	44.88
ANTENNA POLARITY & TEST DISTANCE: VERTICAL AT 3 M								
NO.	FREQ. (MHz)	EMISSION LEVEL (dBuV/m)	LIMIT (dBuV/m)	MARGIN (dB)	ANTENNA HEIGHT (m)	TABLE ANGLE (Degree)	RAW VALUE (dBuV)	CORRECTION FACTOR (dB/m)
1	2386.00	59.99 PK	74.00	-14.01	1.18 V	312	27.67	32.32
2	2386.00	50.82 AV	54.00	-3.18	1.18 V	312	18.50	32.32
3	*2412.00	109.83 PK			1.18 V	81	77.51	32.32
4	*2412.00	105.23 AV			1.18 V	81	72.91	32.32
5	4824.00	46.07 PK	74.00	-27.93	1.00 V	115	8.07	38.00
6	4824.00	35.35 AV	54.00	-18.65	1.00 V	115	-2.65	38.00
7	7236.00	59.28 PK	89.83	-30.55	1.55 V	225	14.40	44.88
8	7236.00	52.81 AV	85.23	-32.42	1.55 V	225	7.93	44.88

- REMARKS:**
1. Emission level (dBuV/m) = Raw Value (dBuV) + Correction Factor (dB/m).
  2. Correction Factor (dB/m) = Antenna Factor (dB/m) + Cable Factor (dB).
  3. The other emission levels were very low against the limit.
  4. Margin value = Emission level – Limit value.
  5. “ \* “: Fundamental frequency.





EUT TEST CONDITION		MEASUREMENT DETAIL	
CHANNEL	Channel 6	FREQUENCY RANGE	1 ~ 25GHz
INPUT POWER	120Vac, 60 Hz	DETECTOR FUNCTION	Peak (PK) Average (AV)
ENVIRONMENTAL CONDITIONS	24deg. C, 64%RH 1020hPa	TESTED BY	Brad Wu

ANTENNA POLARITY & TEST DISTANCE: HORIZONTAL AT 3 M								
NO.	FREQ. (MHz)	EMISSION LEVEL (dBuV/m)	LIMIT (dBuV/m)	MARGIN (dB)	ANTENNA HEIGHT (m)	TABLE ANGLE (Degree)	RAW VALUE (dBuV)	CORRECTION FACTOR (dB/m)
1	*2437.00	98.42 PK			1.04 H	232	66.08	32.34
2	*2437.00	93.85 AV			1.04 H	232	61.51	32.34
3	4874.00	50.88 PK	74.00	-23.12	1.06 H	231	12.76	38.12
4	4874.00	45.73 AV	54.00	-8.27	1.06 H	231	7.61	38.12
5	7311.00	60.20 PK	74.00	-13.80	1.18 H	333	15.24	44.97
6	7311.00	52.81 AV	54.00	-1.19	1.18 H	333	7.84	44.97
ANTENNA POLARITY & TEST DISTANCE: VERTICAL AT 3 M								
NO.	FREQ. (MHz)	EMISSION LEVEL (dBuV/m)	LIMIT (dBuV/m)	MARGIN (dB)	ANTENNA HEIGHT (m)	TABLE ANGLE (Degree)	RAW VALUE (dBuV)	CORRECTION FACTOR (dB/m)
1	*2437.00	110.66 PK			1.14 V	98	78.32	32.34
2	*2437.00	106.09 AV			1.14 V	98	73.75	32.34
3	4874.00	49.25 PK	74.00	-24.75	1.14 V	223	11.13	38.12
4	4874.00	38.46 AV	54.00	-15.54	1.14 V	223	0.34	38.12
5	7311.00	59.22 PK	74.00	-14.78	1.04 V	271	14.25	44.97
6	7311.00	51.94 AV	54.00	-2.06	1.04 V	271	6.97	44.97

- REMARKS:**
1. Emission level (dBuV/m) = Raw Value (dBuV) + Correction Factor (dB/m).
  2. Correction Factor (dB/m) = Antenna Factor (dB/m) + Cable Factor (dB).
  3. The other emission levels were very low against the limit.
  4. Margin value = Emission level – Limit value.
  5. “ \* “: Fundamental frequency.



EUT TEST CONDITION		MEASUREMENT DETAIL	
CHANNEL	Channel 11	FREQUENCY RANGE	1 ~ 25GHz
INPUT POWER	120Vac, 60 Hz	DETECTOR FUNCTION	Peak (PK) Average (AV)
ENVIRONMENTAL CONDITIONS	24deg. C, 64%RH 1020hPa	TESTED BY	Brad Wu

ANTENNA POLARITY & TEST DISTANCE: HORIZONTAL AT 3 M								
NO.	FREQ. (MHz)	EMISSION LEVEL (dBuV/m)	LIMIT (dBuV/m)	MARGIN (dB)	ANTENNA HEIGHT (m)	TABLE ANGLE (Degree)	RAW VALUE (dBuV)	CORRECTION FACTOR (dB/m)
1	*2462.00	98.73 PK			1.08 H	238	66.36	32.37
2	*2462.00	94.11 AV			1.08 H	238	61.74	32.37
3	2483.50	55.73 PK	74.00	-18.27	1.08 H	238	23.34	32.39
4	2483.50	45.52 AV	54.00	-8.48	1.08 H	238	13.13	32.39
5	4924.00	47.56 PK	74.00	-26.44	1.26 H	31	9.33	38.23
6	4924.00	39.39 AV	54.00	-14.61	1.26 H	31	1.16	38.23
7	7386.00	59.91 PK	74.00	-14.09	1.03 H	154	14.88	45.03
8	7386.00	52.88 AV	54.00	-1.12	1.03 H	154	7.85	45.03
ANTENNA POLARITY & TEST DISTANCE: VERTICAL AT 3 M								
NO.	FREQ. (MHz)	EMISSION LEVEL (dBuV/m)	LIMIT (dBuV/m)	MARGIN (dB)	ANTENNA HEIGHT (m)	TABLE ANGLE (Degree)	RAW VALUE (dBuV)	CORRECTION FACTOR (dB/m)
1	*2462.00	110.57 PK			1.12 V	102	78.20	32.37
2	*2462.00	105.97 AV			1.12 V	102	73.60	32.37
3	2488.00	60.61 PK	74.00	-13.39	1.13 V	94	28.22	32.39
4	2488.00	51.30 AV	54.00	-2.70	1.13 V	94	18.91	32.39
5	4924.00	46.96 PK	74.00	-27.04	1.09 V	109	8.73	38.23
6	4924.00	38.31 AV	54.00	-15.69	1.09 V	109	0.08	38.23
7	7386.00	59.75 PK	74.00	-14.25	1.00 V	256	14.73	45.03
8	7386.00	52.83 AV	54.00	-1.17	1.00 V	256	7.81	45.03

- REMARKS:**
1. Emission level (dBuV/m) = Raw Value (dBuV) + Correction Factor (dB/m).
  2. Correction Factor (dB/m) = Antenna Factor (dB/m) + Cable Factor (dB).
  3. The other emission levels were very low against the limit.
  4. Margin value = Emission level – Limit value.
  5. “ \* “: Fundamental frequency.



### 802.11g OFDM MODULATION

EUT TEST CONDITION		MEASUREMENT DETAIL	
CHANNEL	Channel 1	FREQUENCY RANGE	1 ~ 25GHz
INPUT POWER	120Vac, 60 Hz	DETECTOR FUNCTION	Peak (PK) Average (AV)
ENVIRONMENTAL CONDITIONS	24deg. C, 64%RH 1020hPa	TESTED BY	Brad Wu

ANTENNA POLARITY & TEST DISTANCE: HORIZONTAL AT 3 M								
NO.	FREQ. (MHz)	EMISSION LEVEL (dBuV/m)	LIMIT (dBuV/m)	MARGIN (dB)	ANTENNA HEIGHT (m)	TABLE ANGLE (Degree)	RAW VALUE (dBuV)	CORRECTION FACTOR (dB/m)
1	2390.00	57.44 PK	74.00	-16.56	1.01 H	221	25.12	32.32
2	2390.00	46.47 AV	54.00	-7.53	1.01 H	221	14.15	32.32
3	*2412.00	97.52 PK			1.01 H	221	65.20	32.32
4	*2412.00	87.15 AV			1.01 H	221	54.83	32.32
5	4824.00	45.37 PK	74.00	-28.63	1.00 H	145	7.37	38.00
6	4824.00	32.60 AV	54.00	-21.40	1.00 H	145	-5.40	38.00
ANTENNA POLARITY & TEST DISTANCE: VERTICAL AT 3 M								
NO.	FREQ. (MHz)	EMISSION LEVEL (dBuV/m)	LIMIT (dBuV/m)	MARGIN (dB)	ANTENNA HEIGHT (m)	TABLE ANGLE (Degree)	RAW VALUE (dBuV)	CORRECTION FACTOR (dB/m)
1	2390.00	71.11 PK	74.00	-2.89	1.16 V	281	38.79	32.32
2	2390.00	52.82 AV	54.00	-1.18	1.16 V	281	20.50	32.32
3	*2412.00	111.45 PK			1.17 V	91	79.13	32.32
4	*2412.00	100.55 AV			1.17 V	91	68.23	32.32
5	4824.00	45.82 PK	74.00	-28.18	1.00 V	201	7.82	38.00
6	4824.00	32.19 AV	54.00	-21.81	1.00 V	201	-5.81	38.00

- REMARKS:**
1. Emission level (dBuV/m) = Raw Value (dBuV) + Correction Factor (dB/m).
  2. Correction Factor (dB/m) = Antenna Factor (dB/m) + Cable Factor (dB).
  3. The other emission levels were very low against the limit.
  4. Margin value = Emission level – Limit value.
  5. “ \* ”: Fundamental frequency.



EUT TEST CONDITION		MEASUREMENT DETAIL	
CHANNEL	Channel 6	FREQUENCY RANGE	1 ~ 25GHz
INPUT POWER	120Vac, 60 Hz	DETECTOR FUNCTION	Peak (PK) Average (AV)
ENVIRONMENTAL CONDITIONS	24deg. C, 64%RH 1020hPa	TESTED BY	Brad Wu

ANTENNA POLARITY & TEST DISTANCE: HORIZONTAL AT 3 M								
NO.	FREQ. (MHz)	EMISSION LEVEL (dBuV/m)	LIMIT (dBuV/m)	MARGIN (dB)	ANTENNA HEIGHT (m)	TABLE ANGLE (Degree)	RAW VALUE (dBuV)	CORRECTION FACTOR (dB/m)
1	*2437.00	97.86 PK			1.02 H	223	65.52	32.34
2	*2437.00	87.44 AV			1.02 H	223	55.10	32.34
3	4874.00	46.47 PK	74.00	-27.53	1.02 H	213	8.35	38.12
4	4874.00	33.41 AV	54.00	-20.59	1.02 H	213	-4.71	38.12
ANTENNA POLARITY & TEST DISTANCE: VERTICAL AT 3 M								
NO.	FREQ. (MHz)	EMISSION LEVEL (dBuV/m)	LIMIT (dBuV/m)	MARGIN (dB)	ANTENNA HEIGHT (m)	TABLE ANGLE (Degree)	RAW VALUE (dBuV)	CORRECTION FACTOR (dB/m)
1	*2437.00	112.14 PK			1.17 V	93	79.80	32.34
2	*2437.00	100.83 AV			1.17 V	93	68.49	32.34
3	4874.00	45.10 PK	74.00	-28.90	1.01 V	20	6.98	38.12
4	4874.00	32.09 AV	54.00	-21.91	1.01 V	20	-6.03	38.12

- REMARKS:**
1. Emission level (dBuV/m) = Raw Value (dBuV) + Correction Factor (dB/m).
  2. Correction Factor (dB/m) = Antenna Factor (dB/m) + Cable Factor (dB).
  3. The other emission levels were very low against the limit.
  4. Margin value = Emission level – Limit value.
  5. “ \* “: Fundamental frequency.



EUT TEST CONDITION		MEASUREMENT DETAIL	
CHANNEL	Channel 11	FREQUENCY RANGE	1 ~ 25GHz
INPUT POWER	120Vac, 60 Hz	DETECTOR FUNCTION	Peak (PK) Average (AV)
ENVIRONMENTAL CONDITIONS	24deg. C, 64%RH 1020hPa	TESTED BY	Brad Wu

ANTENNA POLARITY & TEST DISTANCE: HORIZONTAL AT 3 M								
NO.	FREQ. (MHz)	EMISSION LEVEL (dBuV/m)	LIMIT (dBuV/m)	MARGIN (dB)	ANTENNA HEIGHT (m)	TABLE ANGLE (Degree)	RAW VALUE (dBuV)	CORRECTION FACTOR (dB/m)
1	*2462.00	96.72 PK			1.04 H	226	64.35	32.37
2	*2462.00	86.35 AV			1.04 H	226	53.98	32.37
3	2483.50	56.36 PK	74.00	-17.64	1.04 H	226	23.97	32.39
4	2483.50	45.38 AV	54.00	-8.62	1.04 H	226	12.99	32.39
5	4924.00	45.46 PK	74.00	-28.54	1.11 H	59	7.23	38.23
6	4924.00	32.84 AV	54.00	-21.16	1.11 H	59	-5.39	38.23
ANTENNA POLARITY & TEST DISTANCE: VERTICAL AT 3 M								
NO.	FREQ. (MHz)	EMISSION LEVEL (dBuV/m)	LIMIT (dBuV/m)	MARGIN (dB)	ANTENNA HEIGHT (m)	TABLE ANGLE (Degree)	RAW VALUE (dBuV)	CORRECTION FACTOR (dB/m)
1	*2462.00	110.82 PK			1.17 V	95	78.45	32.37
2	*2462.00	99.51 AV			1.17 V	95	67.14	32.37
3	2483.50	71.41 PK	74.00	-2.59	1.14 V	253	39.02	32.39
4	2483.50	52.86 AV	54.00	-1.14	1.14 V	253	20.47	32.39
5	4924.00	45.10 PK	74.00	-28.90	1.14 V	253	6.87	38.23
6	4924.00	32.31 AV	54.00	-21.69	1.14 V	253	-5.92	38.23

- REMARKS:**
1. Emission level (dBuV/m) = Raw Value (dBuV) + Correction Factor (dB/m).
  2. Correction Factor (dB/m) = Antenna Factor (dB/m) + Cable Factor (dB).
  3. The other emission levels were very low against the limit.
  4. Margin value = Emission level – Limit value.
  5. “ \* “: Fundamental frequency.



**DRAFT 802.11n (20MHz) OFDM MODULATION**

EUT TEST CONDITION		MEASUREMENT DETAIL	
CHANNEL	Channel 1	FREQUENCY RANGE	1 ~ 25GHz
INPUT POWER	120Vac, 60 Hz	DETECTOR FUNCTION	Peak (PK) Average (AV)
ENVIRONMENTAL CONDITIONS	24deg. C, 64%RH 1020hPa	TESTED BY	Brad Wu

ANTENNA POLARITY & TEST DISTANCE: HORIZONTAL AT 3 M								
NO.	FREQ. (MHz)	EMISSION LEVEL (dBuV/m)	LIMIT (dBuV/m)	MARGIN (dB)	ANTENNA HEIGHT (m)	TABLE ANGLE (Degree)	RAW VALUE (dBuV)	CORRECTION FACTOR (dB/m)
1	2390.00	61.57 PK	74.00	-12.43	1.45 H	309	29.25	32.32
2	2390.00	47.72 AV	54.00	-6.28	1.45 H	309	15.40	32.32
3	*2412.00	105.84 PK			1.45 H	309	73.52	32.32
4	*2412.00	95.67 AV			1.45 H	309	63.35	32.32
5	4824.00	46.70 PK	74.00	-27.30	1.05 H	226	8.70	38.00
6	4824.00	33.77 AV	54.00	-20.23	1.05 H	226	-4.23	38.00
ANTENNA POLARITY & TEST DISTANCE: VERTICAL AT 3 M								
NO.	FREQ. (MHz)	EMISSION LEVEL (dBuV/m)	LIMIT (dBuV/m)	MARGIN (dB)	ANTENNA HEIGHT (m)	TABLE ANGLE (Degree)	RAW VALUE (dBuV)	CORRECTION FACTOR (dB/m)
1	2390.00	66.69 PK	74.00	-7.31	1.00 V	95	34.37	32.32
2	2390.00	52.26 AV	54.00	-1.74	1.00 V	95	19.94	32.32
3	*2412.00	111.60 PK			1.00 V	95	79.28	32.32
4	*2412.00	101.44 AV			1.00 V	95	69.12	32.32
5	4824.00	45.22 PK	74.00	-28.78	1.00 V	15	7.22	38.00
6	4824.00	32.70 AV	54.00	-21.30	1.00 V	15	-5.30	38.00

- REMARKS:**
1. Emission level (dBuV/m) = Raw Value (dBuV) + Correction Factor (dB/m).
  2. Correction Factor (dB/m) = Antenna Factor (dB/m) + Cable Factor (dB).
  3. The other emission levels were very low against the limit.
  4. Margin value = Emission level – Limit value.
  5. “ \* ”: Fundamental frequency.



EUT TEST CONDITION		MEASUREMENT DETAIL	
CHANNEL	Channel 6	FREQUENCY RANGE	1 ~ 25GHz
INPUT POWER	120Vac, 60 Hz	DETECTOR FUNCTION	Peak (PK) Average (AV)
ENVIRONMENTAL CONDITIONS	24deg. C, 64%RH 1020hPa	TESTED BY	Brad Wu

ANTENNA POLARITY & TEST DISTANCE: HORIZONTAL AT 3 M								
NO.	FREQ. (MHz)	EMISSION LEVEL (dBuV/m)	LIMIT (dBuV/m)	MARGIN (dB)	ANTENNA HEIGHT (m)	TABLE ANGLE (Degree)	RAW VALUE (dBuV)	CORRECTION FACTOR (dB/m)
1	*2437.00	106.62 PK			1.43 H	311	74.28	32.34
2	*2437.00	96.51 AV			1.43 H	311	64.17	32.34
3	4874.00	46.96 PK	74.00	-27.04	1.15 H	26	8.84	38.12
4	4874.00	34.12 AV	54.00	-19.88	1.15 H	26	-4.00	38.12
ANTENNA POLARITY & TEST DISTANCE: VERTICAL AT 3 M								
NO.	FREQ. (MHz)	EMISSION LEVEL (dBuV/m)	LIMIT (dBuV/m)	MARGIN (dB)	ANTENNA HEIGHT (m)	TABLE ANGLE (Degree)	RAW VALUE (dBuV)	CORRECTION FACTOR (dB/m)
1	*2437.00	112.45 PK			1.09 V	112	80.11	32.34
2	*2437.00	103.12 AV			1.09 V	112	70.78	32.34
3	4874.00	45.83 PK	74.00	-28.17	1.05 V	216	7.71	38.12
4	4874.00	33.14 AV	54.00	-20.86	1.05 V	216	-4.98	38.12

- REMARKS:**
1. Emission level (dBuV/m) = Raw Value (dBuV) + Correction Factor (dB/m).
  2. Correction Factor (dB/m) = Antenna Factor (dB/m) + Cable Factor (dB).
  3. The other emission levels were very low against the limit.
  4. Margin value = Emission level – Limit value.
  5. “ \* “: Fundamental frequency.



EUT TEST CONDITION		MEASUREMENT DETAIL	
CHANNEL	Channel 11	FREQUENCY RANGE	1 ~ 25GHz
INPUT POWER	120Vac, 60 Hz	DETECTOR FUNCTION	Peak (PK) Average (AV)
ENVIRONMENTAL CONDITIONS	24deg. C, 64%RH 1020hPa	TESTED BY	Brad Wu

ANTENNA POLARITY & TEST DISTANCE: HORIZONTAL AT 3 M								
NO.	FREQ. (MHz)	EMISSION LEVEL (dBuV/m)	LIMIT (dBuV/m)	MARGIN (dB)	ANTENNA HEIGHT (m)	TABLE ANGLE (Degree)	RAW VALUE (dBuV)	CORRECTION FACTOR (dB/m)
1	*2462.00	106.85 PK			1.44 H	310	74.48	32.37
2	*2462.00	96.72 AV			1.44 H	310	64.35	32.37
3	2483.50	62.65 PK	74.00	-11.35	1.44 H	310	30.26	32.39
4	2483.50	48.84 AV	54.00	-5.16	1.44 H	310	16.45	32.39
5	4924.00	46.86 PK	74.00	-27.14	1.15 H	236	8.63	38.23
6	4924.00	33.94 AV	54.00	-20.06	1.15 H	236	-4.29	38.23
ANTENNA POLARITY & TEST DISTANCE: VERTICAL AT 3 M								
NO.	FREQ. (MHz)	EMISSION LEVEL (dBuV/m)	LIMIT (dBuV/m)	MARGIN (dB)	ANTENNA HEIGHT (m)	TABLE ANGLE (Degree)	RAW VALUE (dBuV)	CORRECTION FACTOR (dB/m)
1	*2462.00	112.85 PK			1.08 V	110	80.48	32.37
2	*2462.00	103.38 AV			1.08 V	110	71.01	32.37
3	2483.50	65.65 PK	74.00	-8.35	1.08 V	110	33.26	32.39
4	2483.50	52.22 AV	54.00	-1.78	1.08 V	110	19.83	32.39
5	4924.00	45.46 PK	74.00	-28.54	1.14 V	23	7.23	38.23
6	4924.00	32.93 AV	54.00	-21.07	1.14 V	23	-5.30	38.23

- REMARKS:**
1. Emission level (dBuV/m) = Raw Value (dBuV) + Correction Factor (dB/m).
  2. Correction Factor (dB/m) = Antenna Factor (dB/m) + Cable Factor (dB).
  3. The other emission levels were very low against the limit.
  4. Margin value = Emission level – Limit value.
  5. “ \* “: Fundamental frequency.





**DRAFT 802.11n (40MHz) OFDM MODULATION**

EUT TEST CONDITION		MEASUREMENT DETAIL	
CHANNEL	Channel 1	FREQUENCY RANGE	1 ~ 25GHz
INPUT POWER	120Vac, 60 Hz	DETECTOR FUNCTION	Peak (PK) Average (AV)
ENVIRONMENTAL CONDITIONS	24deg. C, 64%RH 1020hPa	TESTED BY	Brad Wu

ANTENNA POLARITY & TEST DISTANCE: HORIZONTAL AT 3 M								
NO.	FREQ. (MHz)	EMISSION LEVEL (dBuV/m)	LIMIT (dBuV/m)	MARGIN (dB)	ANTENNA HEIGHT (m)	TABLE ANGLE (Degree)	RAW VALUE (dBuV)	CORRECTION FACTOR (dB/m)
1	2390.00	59.84 PK	74.00	-14.16	1.44 H	307	27.52	32.32
2	2390.00	46.98 AV	54.00	-7.02	1.44 H	307	14.66	32.32
3	*2422.00	97.23 PK			1.44 H	307	64.90	32.33
4	*2422.00	87.04 AV			1.44 H	307	54.71	32.33
5	4844.00	45.46 PK	74.00	-28.54	1.08 H	124	7.41	38.05
6	4844.00	32.93 AV	54.00	-21.07	1.08 H	124	-5.12	38.05
ANTENNA POLARITY & TEST DISTANCE: VERTICAL AT 3 M								
NO.	FREQ. (MHz)	EMISSION LEVEL (dBuV/m)	LIMIT (dBuV/m)	MARGIN (dB)	ANTENNA HEIGHT (m)	TABLE ANGLE (Degree)	RAW VALUE (dBuV)	CORRECTION FACTOR (dB/m)
1	2390.00	66.37 PK	74.00	-7.63	1.00 V	309	34.05	32.32
2	2390.00	52.42 AV	54.00	-1.58	1.00 V	309	20.10	32.32
3	*2422.00	105.48 PK			1.00 V	309	73.15	32.33
4	*2422.00	95.87 AV			1.00 V	309	63.54	32.33
5	4844.00	45.13 PK	74.00	-28.87	1.02 V	218	7.08	38.05
6	4844.00	32.51 AV	54.00	-21.49	1.02 V	218	-5.54	38.05

- REMARKS:**
1. Emission level (dBuV/m) = Raw Value (dBuV) + Correction Factor (dB/m).
  2. Correction Factor (dB/m) = Antenna Factor (dB/m) + Cable Factor (dB).
  3. The other emission levels were very low against the limit.
  4. Margin value = Emission level – Limit value.
  5. “ \* “: Fundamental frequency.



EUT TEST CONDITION		MEASUREMENT DETAIL	
CHANNEL	Channel 4	FREQUENCY RANGE	1 ~ 25GHz
INPUT POWER	120Vac, 60 Hz	DETECTOR FUNCTION	Peak (PK) Average (AV)
ENVIRONMENTAL CONDITIONS	24deg. C, 64%RH 1020hPa	TESTED BY	Brad Wu

ANTENNA POLARITY & TEST DISTANCE: HORIZONTAL AT 3 M								
NO.	FREQ. (MHz)	EMISSION LEVEL (dBuV/m)	LIMIT (dBuV/m)	MARGIN (dB)	ANTENNA HEIGHT (m)	TABLE ANGLE (Degree)	RAW VALUE (dBuV)	CORRECTION FACTOR (dB/m)
1	*2437.00	97.95 PK			1.43 H	310	65.61	32.34
2	*2437.00	87.82 AV			1.43 H	310	55.48	32.34
3	4874.00	45.96 PK	74.00	-28.04	1.01 H	235	7.84	38.12
4	4874.00	33.24 AV	54.00	-20.76	1.01 H	235	-4.88	38.12
ANTENNA POLARITY & TEST DISTANCE: VERTICAL AT 3 M								
NO.	FREQ. (MHz)	EMISSION LEVEL (dBuV/m)	LIMIT (dBuV/m)	MARGIN (dB)	ANTENNA HEIGHT (m)	TABLE ANGLE (Degree)	RAW VALUE (dBuV)	CORRECTION FACTOR (dB/m)
1	*2437.00	106.21 PK			1.01 V	310	73.87	32.34
2	*2437.00	96.54 AV			1.01 V	310	64.20	32.34
3	4874.00	45.86 PK	74.00	-28.14	1.05 V	119	7.74	38.12
4	4874.00	33.23 AV	54.00	-20.77	1.05 V	119	-4.89	38.12

- REMARKS:**
1. Emission level (dBuV/m) = Raw Value (dBuV) + Correction Factor (dB/m).
  2. Correction Factor (dB/m) = Antenna Factor (dB/m) + Cable Factor (dB).
  3. The other emission levels were very low against the limit.
  4. Margin value = Emission level – Limit value.
  5. “ \* “: Fundamental frequency.



EUT TEST CONDITION		MEASUREMENT DETAIL	
CHANNEL	Channel 7	FREQUENCY RANGE	1 ~ 25GHz
INPUT POWER	120Vac, 60 Hz	DETECTOR FUNCTION	Peak (PK) Average (AV)
ENVIRONMENTAL CONDITIONS	24deg. C, 64%RH 1020hPa	TESTED BY	Brad Wu

ANTENNA POLARITY & TEST DISTANCE: HORIZONTAL AT 3 M								
NO.	FREQ. (MHz)	EMISSION LEVEL (dBuV/m)	LIMIT (dBuV/m)	MARGIN (dB)	ANTENNA HEIGHT (m)	TABLE ANGLE (Degree)	RAW VALUE (dBuV)	CORRECTION FACTOR (dB/m)
1	*2452.00	98.21 PK			1.42 H	315	65.85	32.36
2	*2452.00	88.16 AV			1.42 H	315	55.80	32.36
3	2483.50	59.94 PK	74.00	-14.06	1.42 H	315	27.55	32.39
4	2483.50	47.21 AV	54.00	-6.79	1.42 H	315	14.82	32.39
5	4904.00	46.21 PK	74.00	-27.79	1.01 H	38	8.02	38.19
6	4904.00	33.55 AV	54.00	-20.45	1.01 H	38	-4.64	38.19
ANTENNA POLARITY & TEST DISTANCE: VERTICAL AT 3 M								
NO.	FREQ. (MHz)	EMISSION LEVEL (dBuV/m)	LIMIT (dBuV/m)	MARGIN (dB)	ANTENNA HEIGHT (m)	TABLE ANGLE (Degree)	RAW VALUE (dBuV)	CORRECTION FACTOR (dB/m)
1	*2452.00	106.45 PK			1.02 V	308	74.09	32.36
2	*2452.00	96.75 AV			1.02 V	308	64.39	32.36
3	2483.50	66.52 PK	74.00	-7.48	1.02 V	308	34.13	32.39
4	2483.50	52.68 AV	54.00	-1.32	1.02 V	308	20.29	32.39
5	4904.00	46.23 PK	74.00	-27.77	1.08 V	231	8.04	38.19
6	4904.00	33.51 AV	54.00	-20.49	1.08 V	231	-4.68	38.19

- REMARKS:**
1. Emission level (dBuV/m) = Raw Value (dBuV) + Correction Factor (dB/m).
  2. Correction Factor (dB/m) = Antenna Factor (dB/m) + Cable Factor (dB).
  3. The other emission levels were very low against the limit.
  4. Margin value = Emission level – Limit value.
  5. “ \* “: Fundamental frequency.



**BELOW 1GHz WORST-CASE DATA : DRAFT 802.11n (20MHz) OFDM MODULATION**

EUT TEST CONDITION		MEASUREMENT DETAIL	
CHANNEL	Channel 1	FREQUENCY RANGE	Below 1000MHz
INPUT POWER	120Vac, 60 Hz	DETECTOR FUNCTION	Quasi-Peak
ENVIRONMENTAL CONDITIONS	25deg. C, 65%RH 1020hPa	TESTED BY	Brad Wu

ANTENNA POLARITY & TEST DISTANCE: HORIZONTAL AT 3 M								
NO.	FREQ. (MHz)	EMISSION LEVEL (dBuV/m)	LIMIT (dBuV/m)	MARGIN (dB)	ANTENNA HEIGHT (m)	TABLE ANGLE (Degree)	RAW VALUE (dBuV)	CORRECTION FACTOR (dB/m)
1	451.81	33.12 QP	46.00	-12.88	2.00 H	109	15.85	17.27
2	500.42	32.56 QP	46.00	-13.44	1.50 H	139	13.80	18.76
3	601.52	31.97 QP	46.00	-14.03	1.00 H	133	10.86	21.11
4	751.23	34.71 QP	46.00	-11.29	2.00 H	277	11.49	23.22
5	852.33	35.33 QP	46.00	-10.67	1.50 H	142	10.47	24.87
6	953.44	35.93 QP	46.00	-10.07	2.00 H	139	10.19	25.74
ANTENNA POLARITY & TEST DISTANCE: VERTICAL AT 3 M								
NO.	FREQ. (MHz)	EMISSION LEVEL (dBuV/m)	LIMIT (dBuV/m)	MARGIN (dB)	ANTENNA HEIGHT (m)	TABLE ANGLE (Degree)	RAW VALUE (dBuV)	CORRECTION FACTOR (dB/m)
1	97.95	39.39 QP	43.50	-4.11	1.00 V	262	30.27	9.12
2	401.26	35.13 QP	46.00	-10.87	1.50 V	310	19.39	15.75
3	500.42	37.33 QP	46.00	-8.67	1.50 V	163	18.57	18.76
4	751.23	35.73 QP	46.00	-10.27	1.50 V	193	12.50	23.22
5	852.33	33.75 QP	46.00	-12.25	1.00 V	259	8.88	24.87
6	957.33	37.14 QP	46.00	-8.86	1.00 V	7	11.38	25.75

- REMARKS:**
1. Emission level (dBuV/m) = Raw Value (dBuV) + Correction Factor (dB/m).
  2. Correction Factor (dB/m) = Antenna Factor (dB/m) + Cable Factor (dB).
  3. The other emission levels were very low against the limit.
  4. Margin value = Emission level – Limit value.

## 4.2 CONDUCTED EMISSION MEASUREMENT

### 4.2.1 LIMITS OF CONDUCTED EMISSION MEASUREMENT

FREQUENCY OF EMISSION (MHz)	CONDUCTED LIMIT (dB $\mu$ V)	
	Quasi-peak	Average
0.15-0.5	66 to 56	56 to 46
0.5-5	56	46
5-30	60	50

- NOTE:**
1. The lower limit shall apply at the transition frequencies.
  2. The limit decreases in line with the logarithm of the frequency in the range of 0.15 to 0.50 MHz.
  3. All emanations from a class A/B digital device or system, including any network of conductors and apparatus connected thereto, shall not exceed the level of field strengths specified above.

### 4.2.2 TEST INSTRUMENTS

DESCRIPTION & MANUFACTURER	MODEL NO.	SERIAL NO.	CALIBRATED UNTIL
Test Receiver ROHDE & SCHWARZ	ESCS30	100288	Sep. 21, 2008
RF signal cable Woken	5D-FB	Cable-HYCO3-01	Jan. 06, 2009
LISN ROHDE & SCHWARZ	ESH2-Z5	100100	Jan. 09, 2009
LISN ROHDE & SCHWARZ	ESH3-Z5	100311	Jan. 16, 2008
Software ADT	ADT_Cond_V3	NA	NA

- NOTE:**
1. The calibration interval of the above test instruments is 12 months and the calibrations are traceable to NML/ROC and NIST/USA.
  2. The test was performed in HwaYa Shielded Room 2.
  3. The VCCI Site Registration No. is C-2047.

#### 4.2.3 TEST PROCEDURES

- a. The EUT was placed 0.4 meters from the conducting wall of the shielded room with EUT being connected to the power mains through a line impedance stabilization network (LISN). Other support units were connected to the power mains through another LISN. The two LISNs provide 50 ohm/ 50uH of coupling impedance for the measuring instrument.
- b. Both lines of the power mains connected to the EUT were checked for maximum conducted interference.
- c. The frequency range from 150kHz to 30MHz was searched. Emission levels under (Limit - 20dB) was not recorded.

#### 4.2.4 DEVIATION FROM TEST STANDARD

No deviation

#### 4.2.5 TEST SETUP

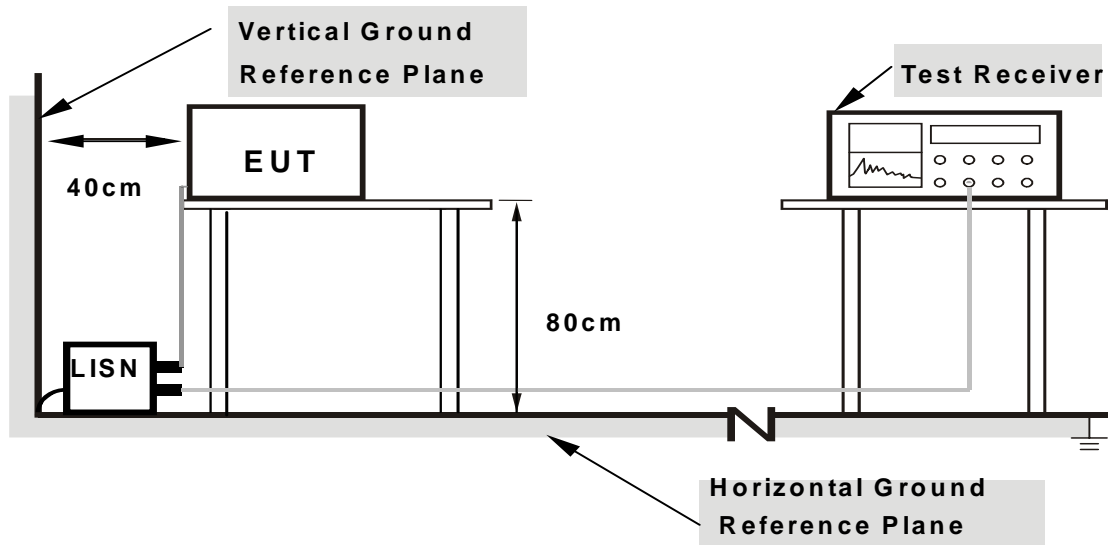

**Note: 1.Support units were connected to second LISN.**

**2.Both of LISNs (AMN) are 80 cm from EUT and at least 80 from other units and other metal planes**

For the actual test configuration, please refer to the attached file (Test Setup Photo).

#### 4.2.6 EUT OPERATING CONDITIONS

Same as 4.1.6.

## 4.2.7 TEST RESULTS

### CONDUCTED WORST-CASE DATA DRAFT 802.11n (20MHz) OFDM MODULATION

EUT TEST CONDITION		MEASUREMENT DETAIL	
CHANNEL	Channel 1	PHASE	Line 1
MODULATION TYPE	BPSK	6dB BANDWIDTH	9 kHz
ENVIRONMENTAL CONDITIONS	25deg. C, 65% RH, 983hPa	INPUT POWER	120Vac, 60 Hz
TESTED BY	Lori Chiu		

No	Freq. [MHz]	Corr. Factor (dB)	Reading Value		Emission Level		Limit		Margin	
			[dB (uV)]		[dB (uV)]		[dB (uV)]		(dB)	
			Q.P.	AV.	Q.P.	AV.	Q.P.	AV.	Q.P.	AV.
1	0.197	0.10	46.92	-	47.02	-	63.74	53.74	-16.72	-
2	0.334	0.10	37.15	-	37.25	-	59.36	49.36	-22.11	-
3	0.392	0.10	36.38	-	36.48	-	58.02	48.02	-21.54	-
4	0.595	0.10	35.25	-	35.35	-	56.00	46.00	-20.65	-
5	3.461	0.26	30.47	-	30.73	-	56.00	46.00	-25.27	-
6	9.641	0.33	28.96	-	29.29	-	60.00	50.00	-30.71	-

- REMARKS:**
1. Q.P. and AV. are abbreviations of quasi-peak and average individually.
  2. "-": The Quasi-peak reading value also meets average limit and measurement with the average detector is unnecessary.
  3. The emission levels of other frequencies were very low against the limit.
  4. Margin value = Emission level - Limit value
  5. Correction factor = Insertion loss + Cable loss
  6. Emission Level = Correction Factor + Reading Value.

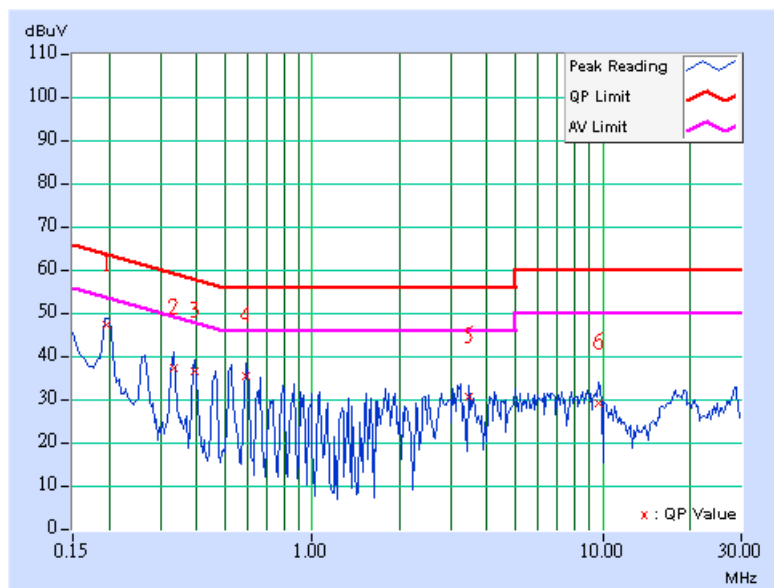



EUT TEST CONDITION		MEASUREMENT DETAIL	
CHANNEL	Channel 1	PHASE	Line 2
MODULATION TYPE	BPSK	6dB BANDWIDTH	9 kHz
ENVIRONMENTAL CONDITIONS	25deg. C, 65% RH, 983hPa	INPUT POWER	120Vac, 60 Hz
TESTED BY	Lori Chiu		

No	Freq. [MHz]	Corr. Factor (dB)	Reading Value		Emission Level		Limit		Margin	
			[dB (uV)]		[dB (uV)]		[dB (uV)]		(dB)	
			Q.P.	AV.	Q.P.	AV.	Q.P.	AV.	Q.P.	AV.
1	0.193	0.10	43.74	-	43.84	-	63.91	53.91	-20.07	-
2	0.459	0.11	35.56	-	35.67	-	56.72	46.72	-21.05	-
3	0.595	0.14	34.35	-	34.49	-	56.00	46.00	-21.51	-
4	0.666	0.15	34.46	-	34.61	-	56.00	46.00	-21.39	-
5	2.328	0.23	32.37	-	32.60	-	56.00	46.00	-23.40	-
6	9.711	0.42	27.84	-	28.26	-	60.00	50.00	-31.74	-

- REMARKS:**
1. Q.P. and AV. are abbreviations of quasi-peak and average individually.
  2. "-": The Quasi-peak reading value also meets average limit and measurement with the average detector is unnecessary.
  3. The emission levels of other frequencies were very low against the limit.
  4. Margin value = Emission level - Limit value
  5. Correction factor = Insertion loss + Cable loss
  6. Emission Level = Correction Factor + Reading Value.

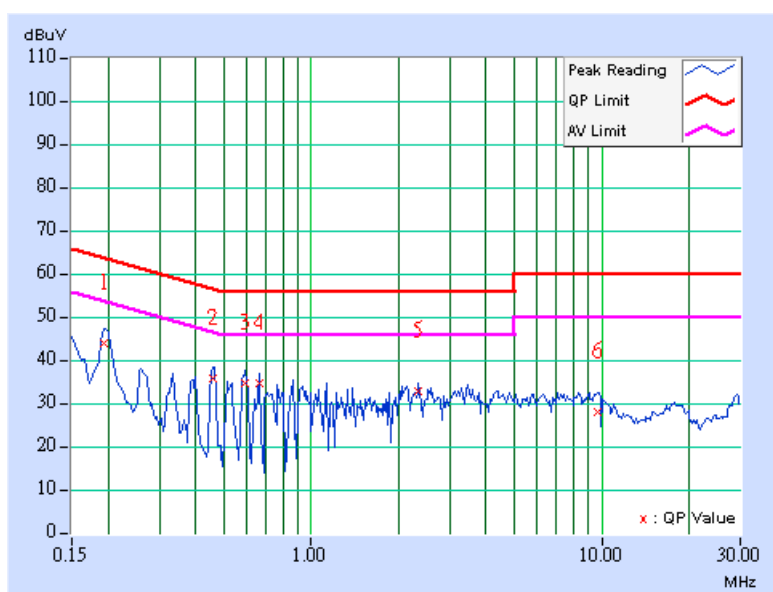



### 4.3 6dB BANDWIDTH MEASUREMENT

#### 4.3.1 LIMITS OF 6dB BANDWIDTH MEASUREMENT

The minimum of 6dB Bandwidth Measurement is 0.5 MHz.

#### 4.3.2 TEST INSTRUMENTS

DESCRIPTION & MANUFACTURER	MODEL NO.	SERIAL NO.	CALIBRATED UNTIL
SPECTRUM ANALYZER	FSP40	100040	Jun. 28, 2008

**NOTE:** The calibration interval of the above test instruments is 12 months and the calibrations are traceable to NML/ROC and NIST/USA.

#### 4.3.3 TEST PROCEDURE

The transmitter output was connected to the spectrum analyzer through an attenuator. The bandwidth of the fundamental frequency was measured by spectrum analyzer with 100kHz RBW and 300kHz VBW. The 6dB bandwidth is defined as the total spectrum the power of which is higher than peak power minus 6dB.

#### 4.3.4 DEVIATION FROM TEST STANDARD

No deviation

#### 4.3.5 TEST SETUP

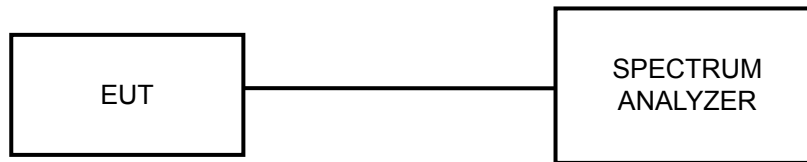

#### 4.3.6 EUT OPERATING CONDITIONS

The software provided by client to enable the EUT under transmission condition continuously at lowest, middle and highest channel frequencies individually.

### 4.3.7 TEST RESULTS

#### 802.11b DSSS MODULATION

<b>MODULATION TYPE</b>	DBPSK	<b>ENVIRONMENTAL CONDITIONS</b>	25deg.C, 65% RH, 987hPa
<b>INPUT POWER</b>	120Vac, 60 Hz	<b>TESTED BY</b>	Brad Wu

CHANNEL	CHANNEL FREQUENCY (MHz)	6dB BANDWIDTH (MHz)	MINIMUM LIMIT (MHz)	PASS / FAIL
1	2412	10.18	0.5	PASS
6	2437	10.14	0.5	PASS
11	2462	11.13	0.5	PASS

#### CH 1

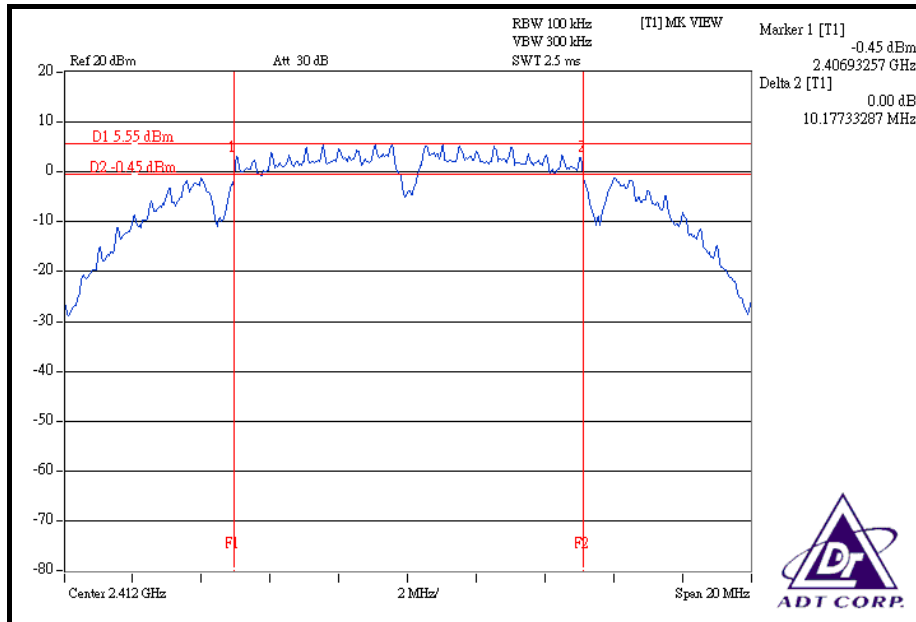

### CH 6

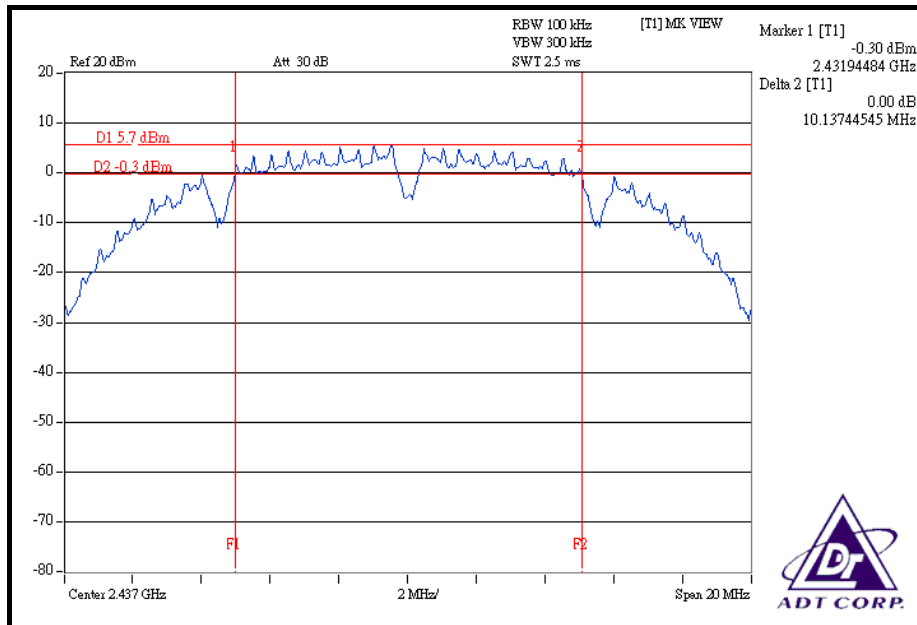

### CH 11

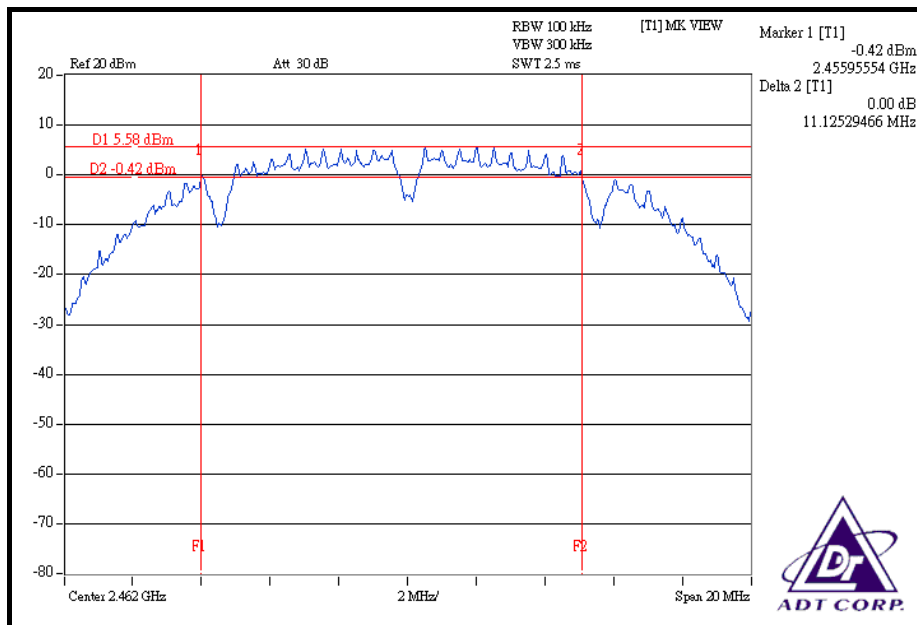

### 802.11g OFDM MODULATION

<b>MODULATION TYPE</b>	BPSK	<b>ENVIRONMENTAL CONDITIONS</b>	25deg.C, 65% RH, 987hPa
<b>INPUT POWER</b>	120Vac, 60 Hz	<b>TESTED BY</b>	Brad Wu

CHANNEL	CHANNEL FREQUENCY (MHz)	6dB BANDWIDTH (MHz)	MINIMUM LIMIT (MHz)	PASS / FAIL
1	2412	16.38	0.5	PASS
6	2437	16.41	0.5	PASS
11	2462	16.44	0.5	PASS

### CH 1

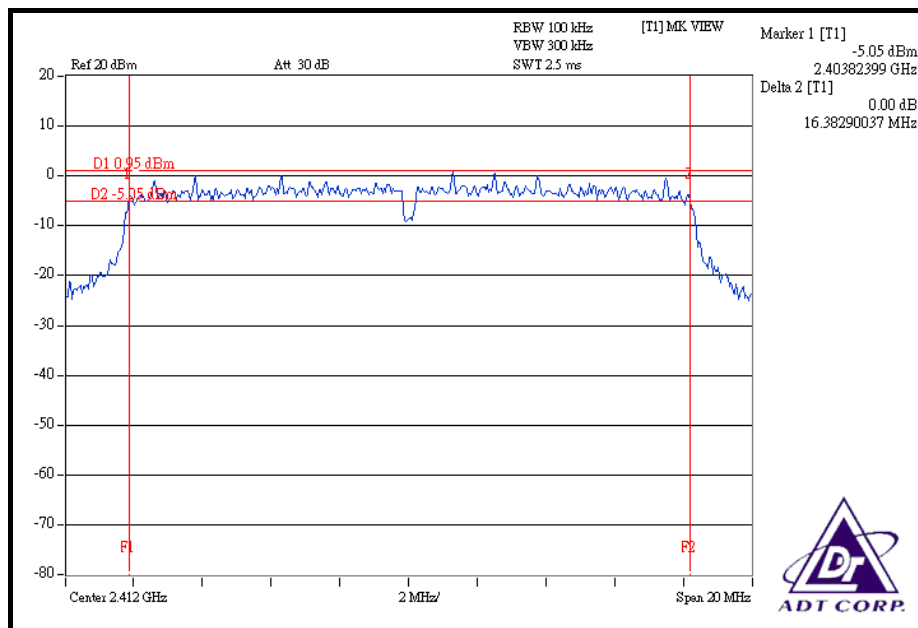

### CH 6

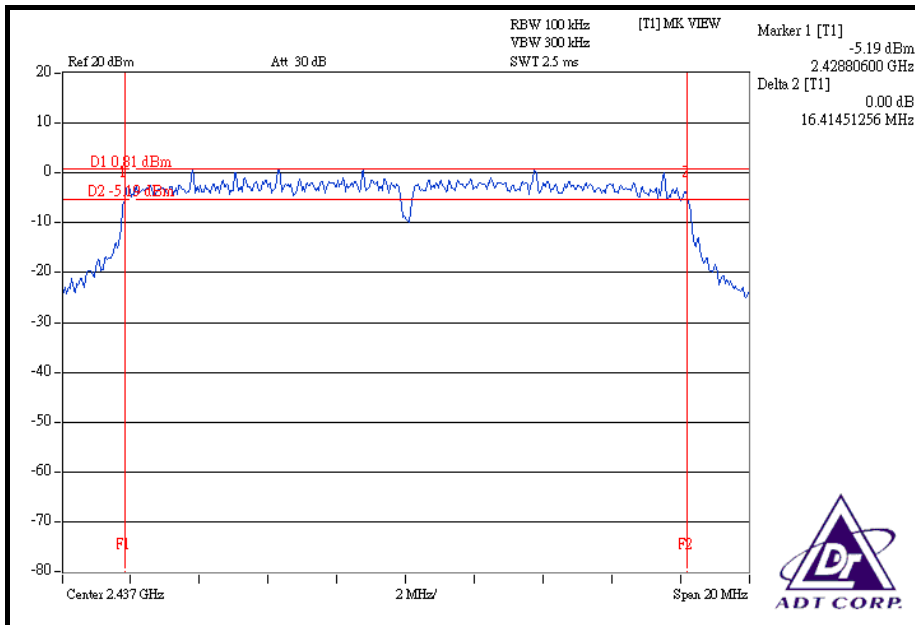

### CH 11

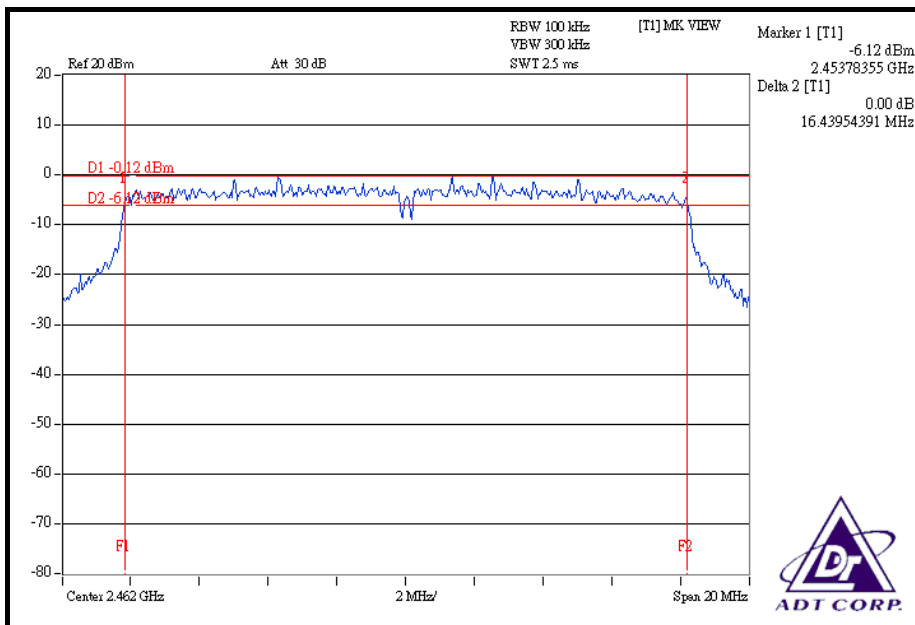



**DRAFT 802.11n (20MHz) OFDM MODULATION**

<b>MODULATION TYPE</b>	BPSK	<b>ENVIRONMENTAL CONDITIONS</b>	25deg.C, 65% RH, 987hPa
<b>INPUT POWER</b>	120Vac, 60 Hz	<b>TESTED BY</b>	Brad Wu

CHANNEL	CHANNEL FREQUENCY (MHz)	6dB BANDWIDTH (MHz)			MINIMUM LIMIT (MHz)	PASS / FAIL
		CHAIN 0	CHAIN 1	CHAIN 2		
1	2412	17.62	17.65	17.61	0.5	PASS
6	2437	17.64	17.66	17.64	0.5	PASS
11	2462	17.65	17.66	17.65	0.5	PASS

**FOR CHAIN 0: CH 1**

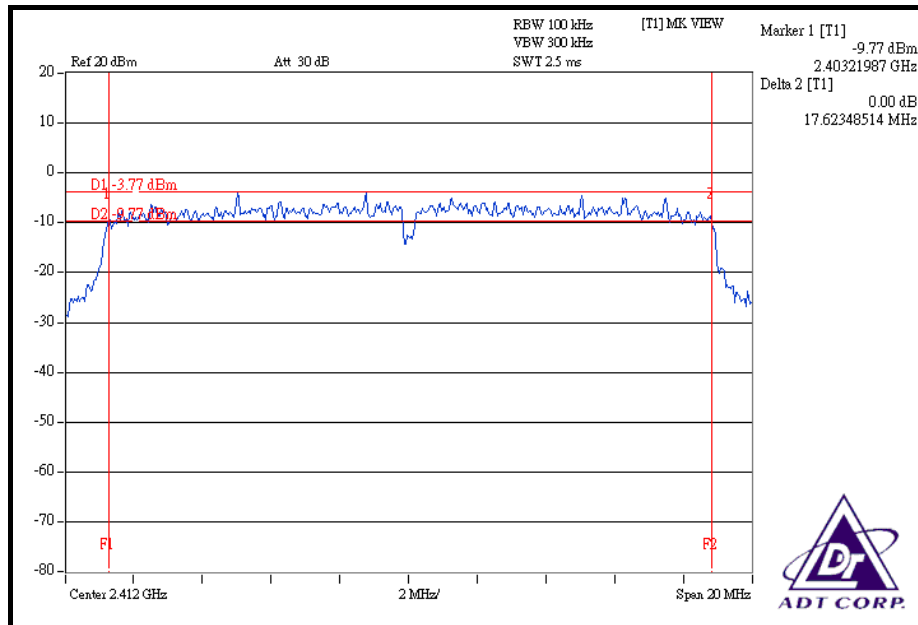



### CH 6

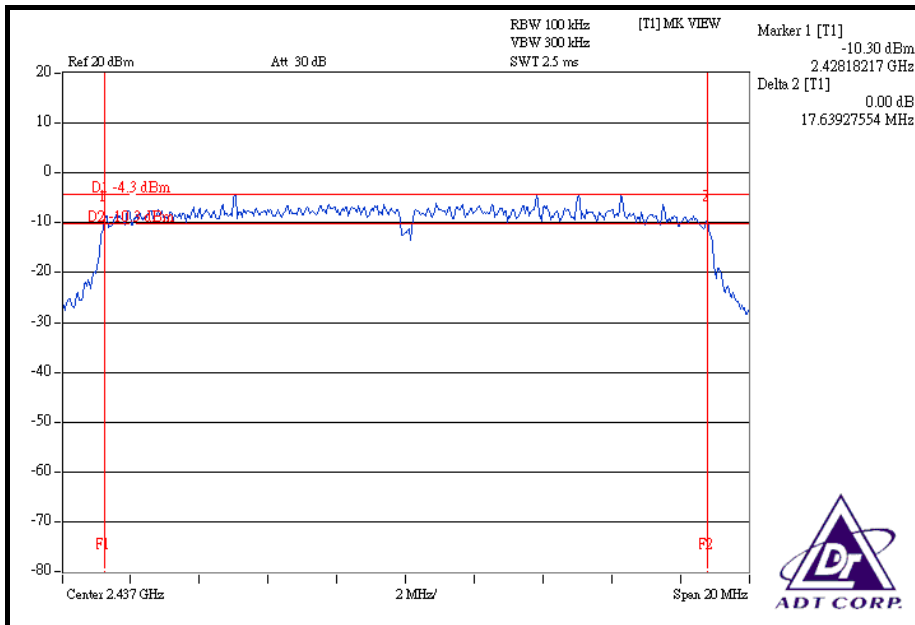

### CH 11

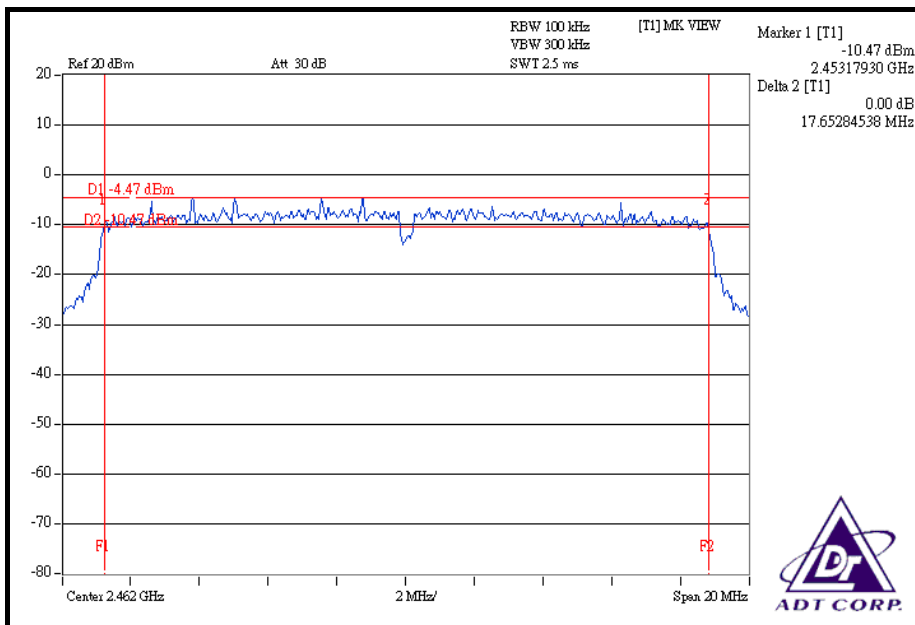

**FOR CHAIN 1: CH 1**

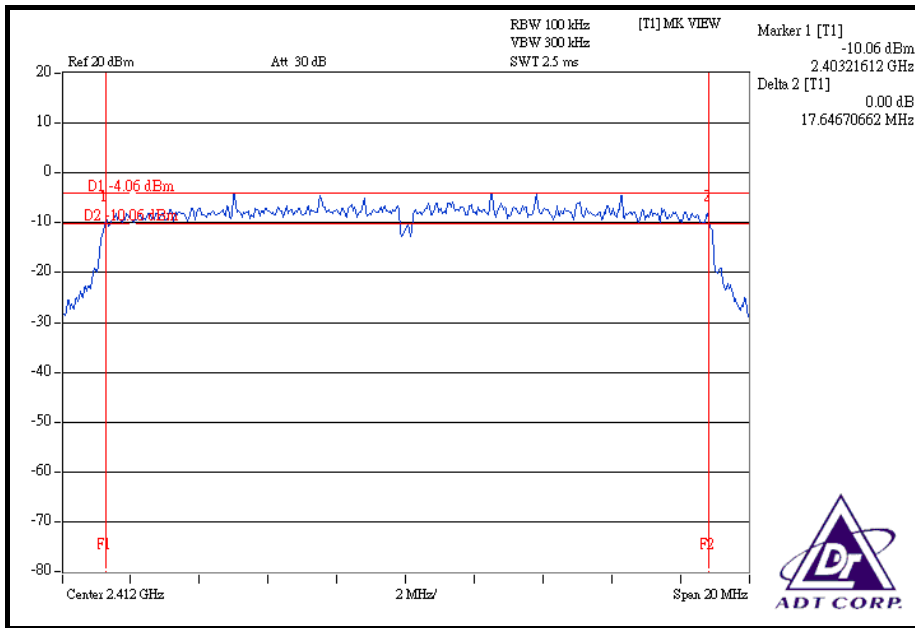

**CH 6**

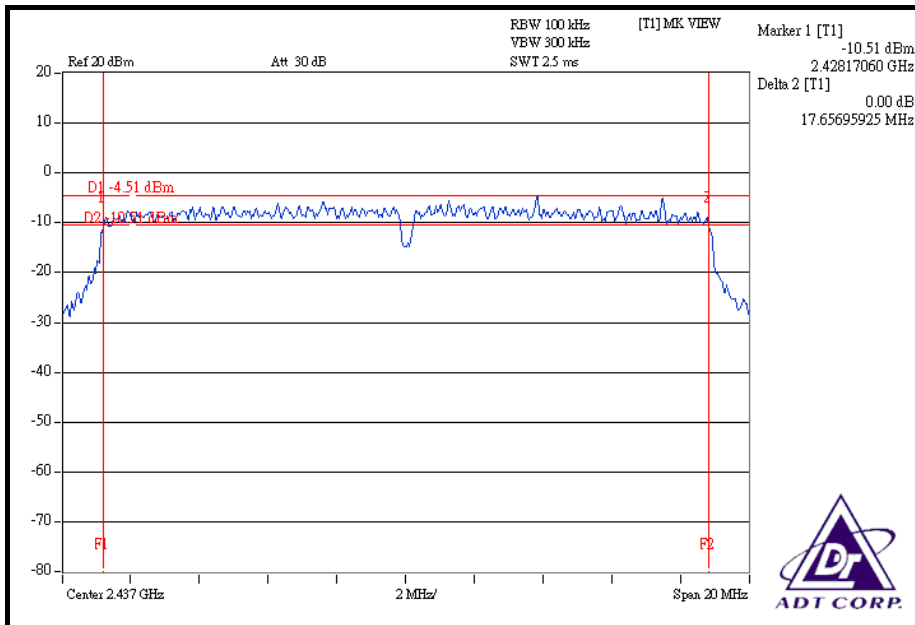

### CH 11

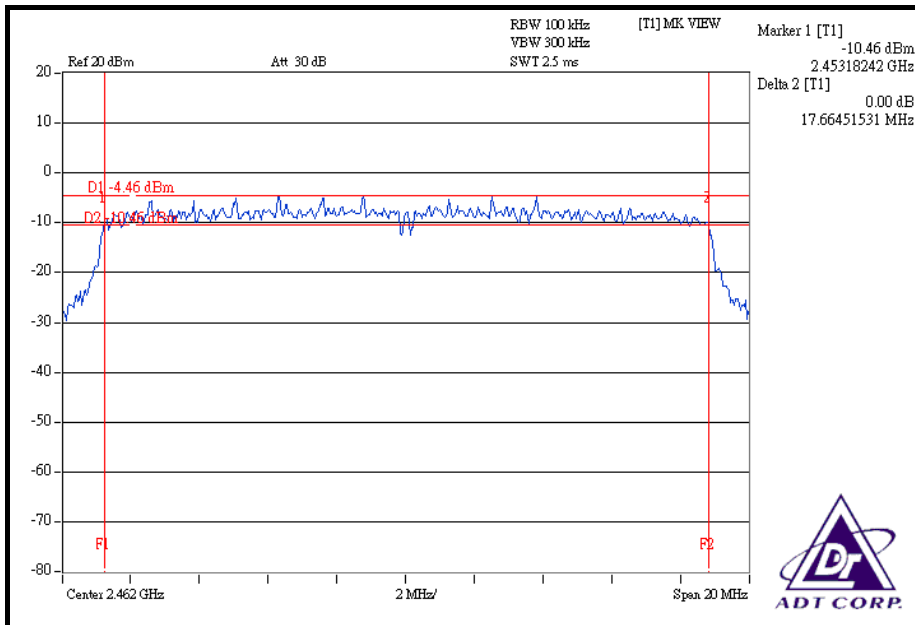

### FOR CHAIN 2: CH 1

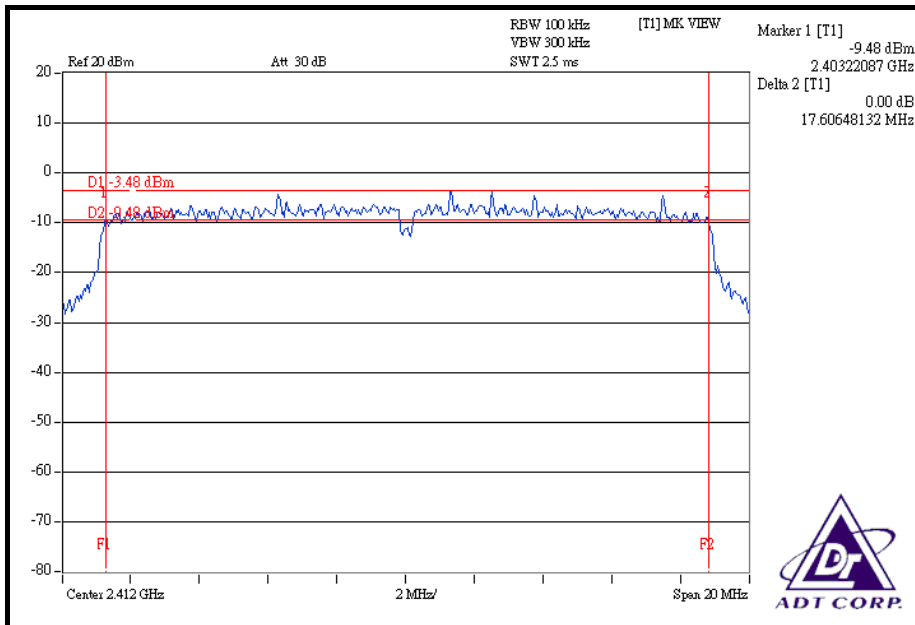

### CH 6

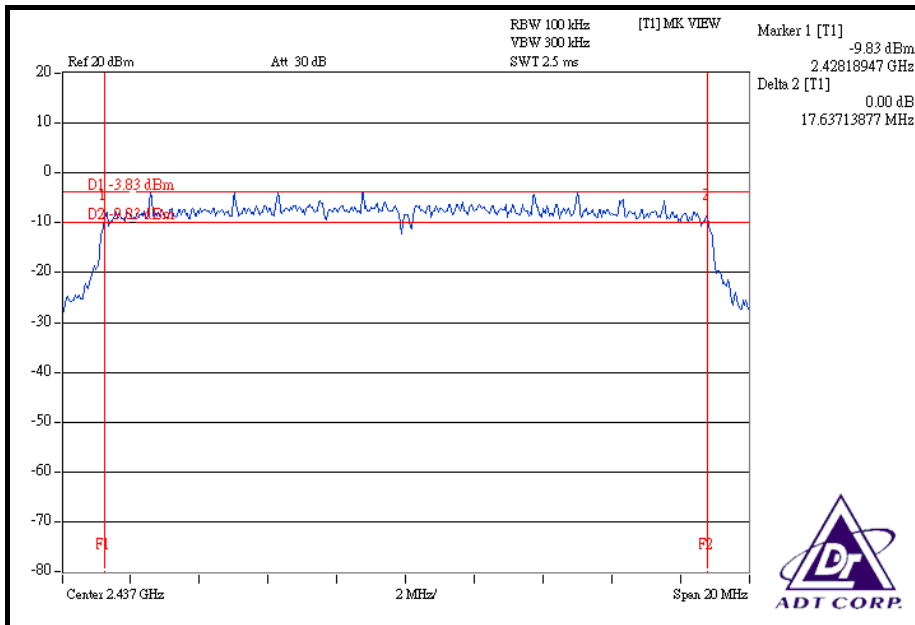

### CH 11

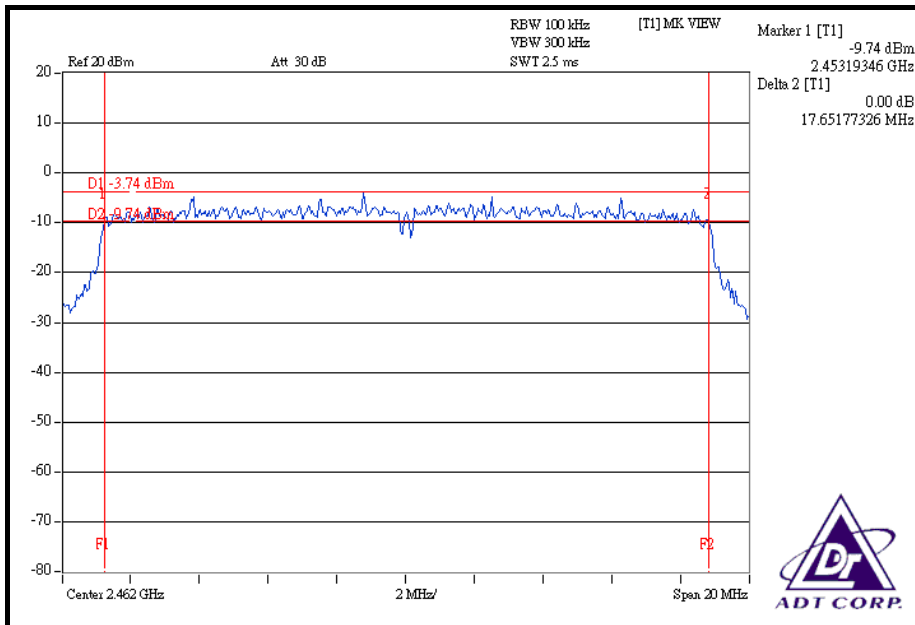



**DRAFT 802.11n (40MHz) OFDM MODULATION**

<b>MODULATION TYPE</b>	BPSK	<b>ENVIRONMENTAL CONDITIONS</b>	25deg.C, 65% RH, 987hPa
<b>INPUT POWER</b>	120Vac, 60 Hz	<b>TESTED BY</b>	Brad Wu

CHANNEL	CHANNEL FREQUENCY (MHz)	6dB BANDWIDTH (MHz)			MINIMUM LIMIT (MHz)	PASS / FAIL
		CHAIN 0	CHAIN 1	CHAIN 2		
1	2422	36.43	36.46	36.45	0.5	PASS
4	2437	36.49	36.50	36.52	0.5	PASS
7	2452	36.50	36.55	36.55	0.5	PASS

**FOR CHAIN 0: CH 1**

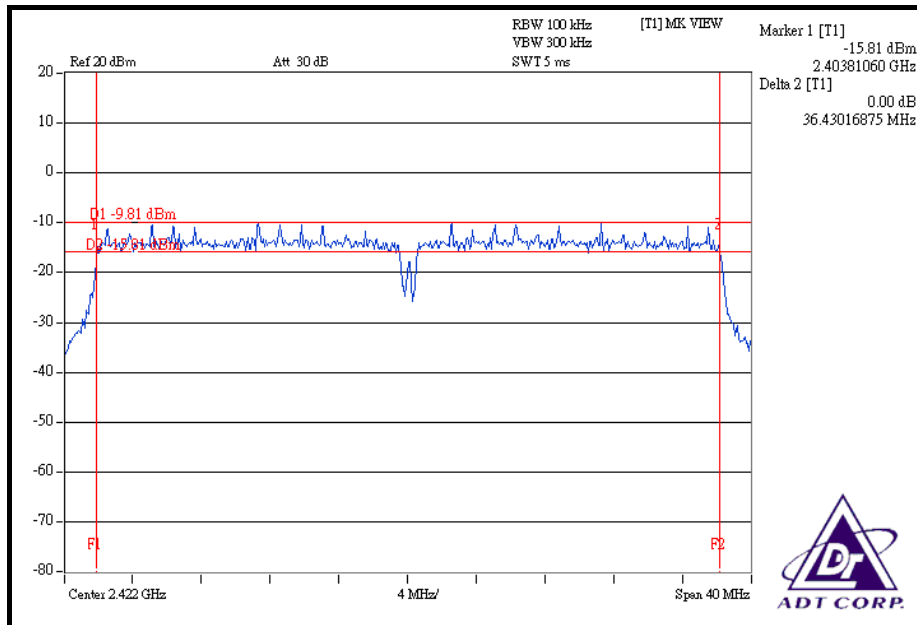

### CH 4

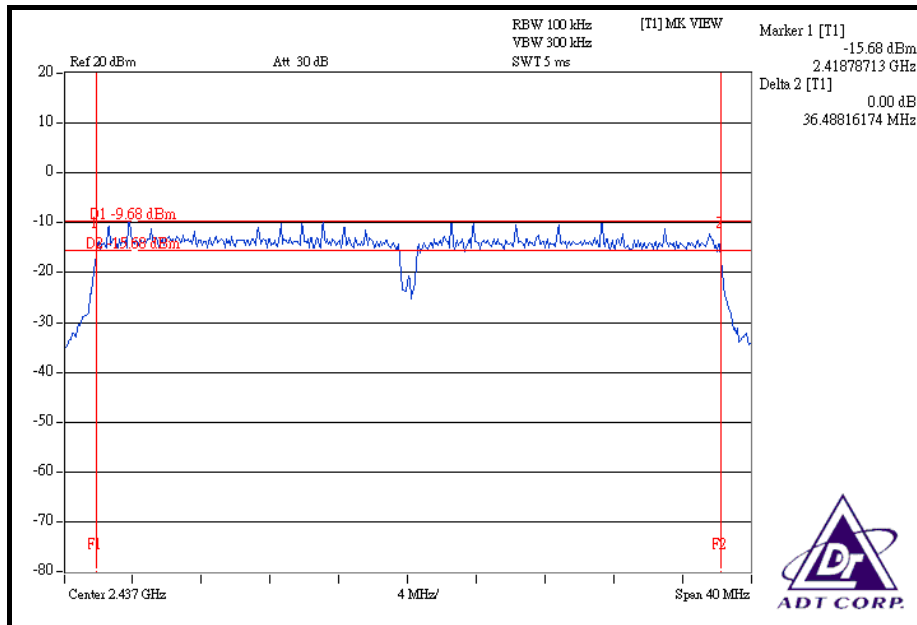

### CH 7

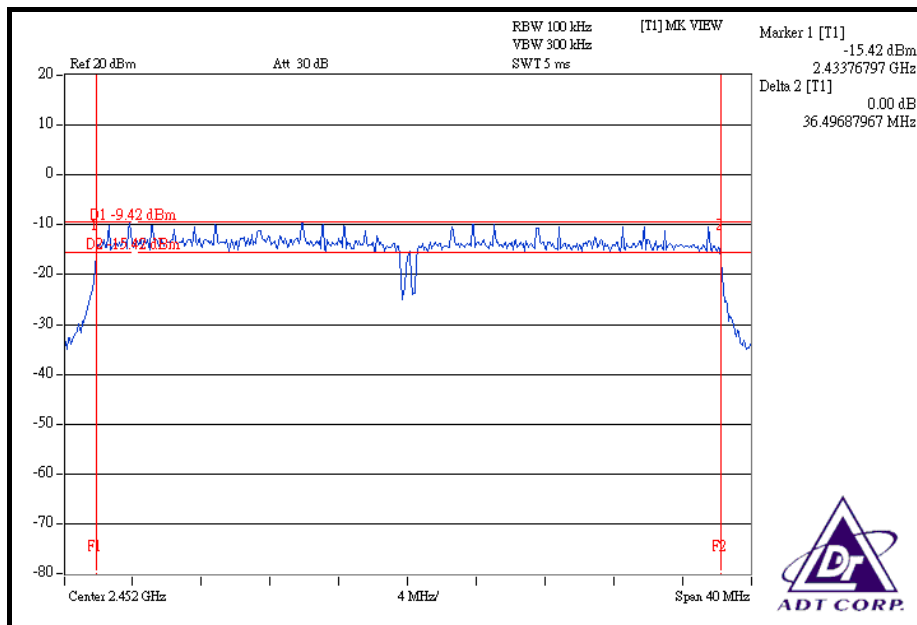

**FOR CHAIN 1: CH 1**

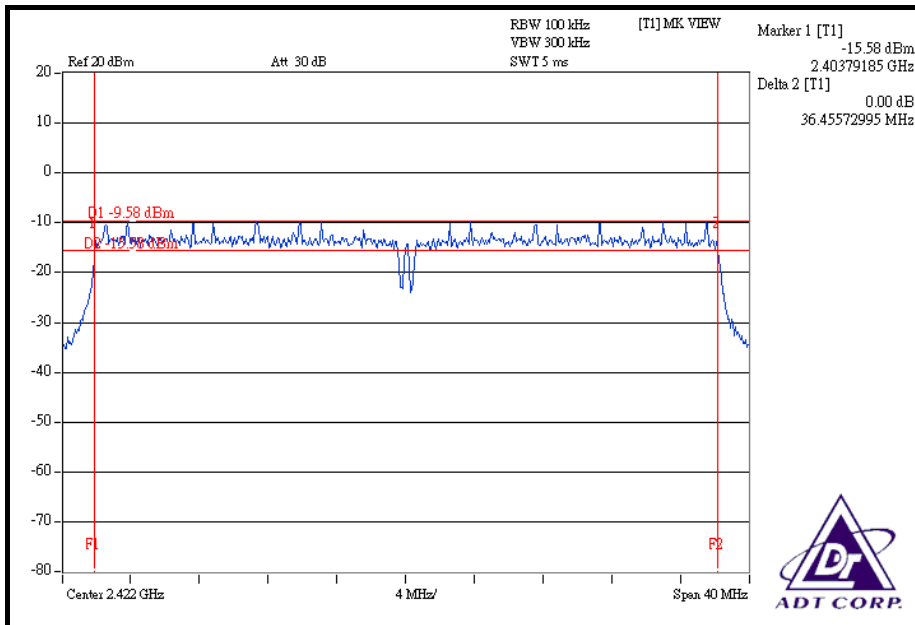

**CH 4**

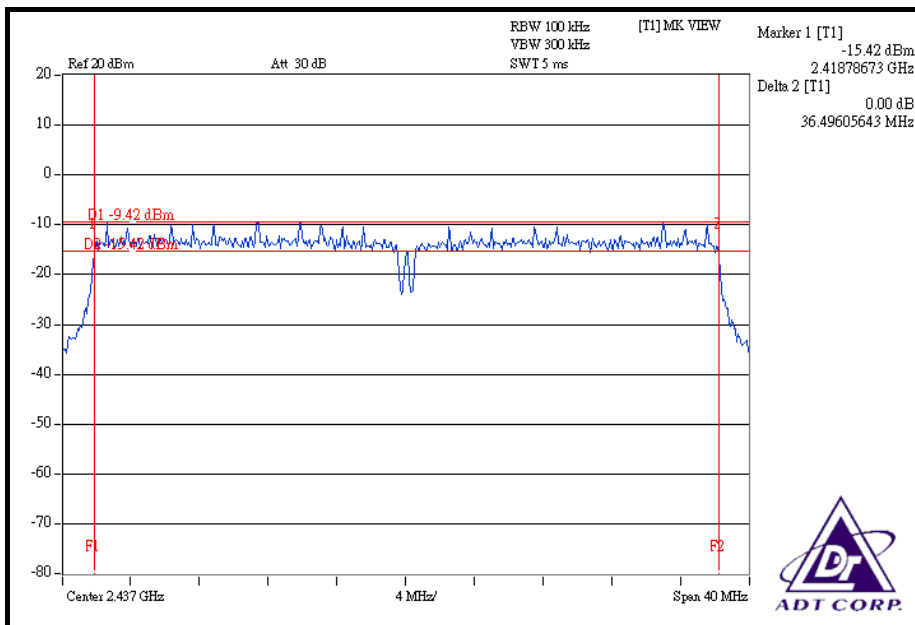

### CH 7

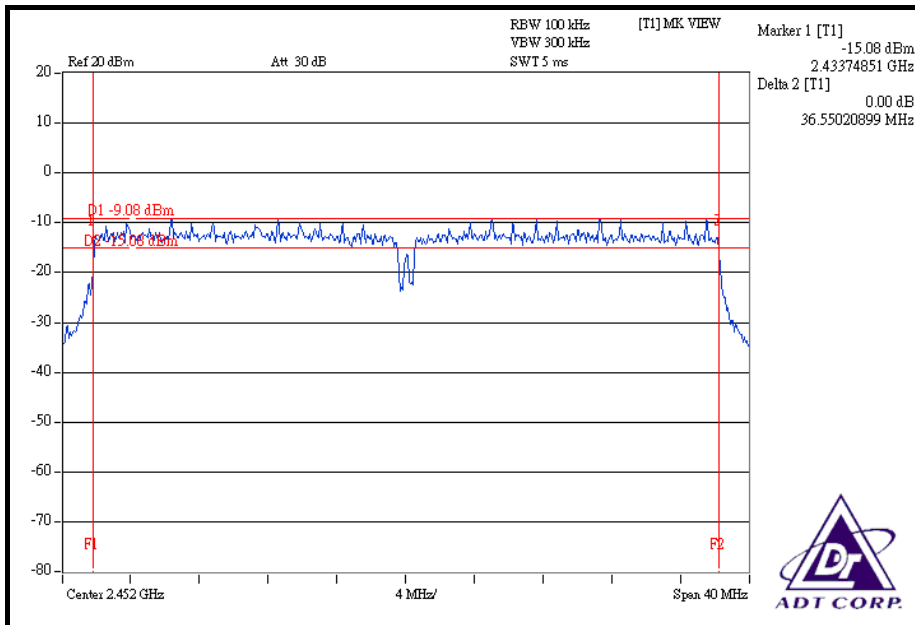

### FOR CHAIN 2: CH 1

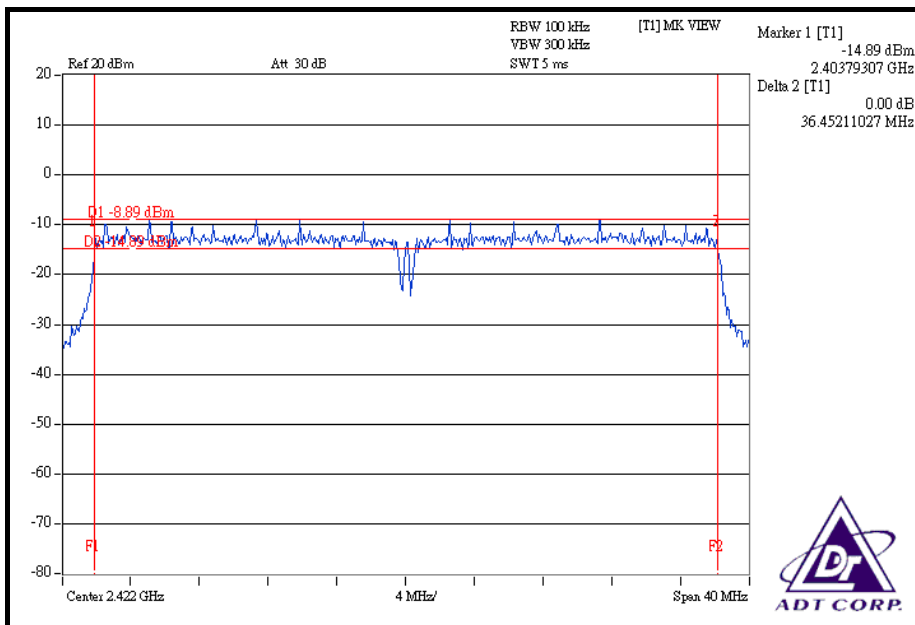



### CH 4

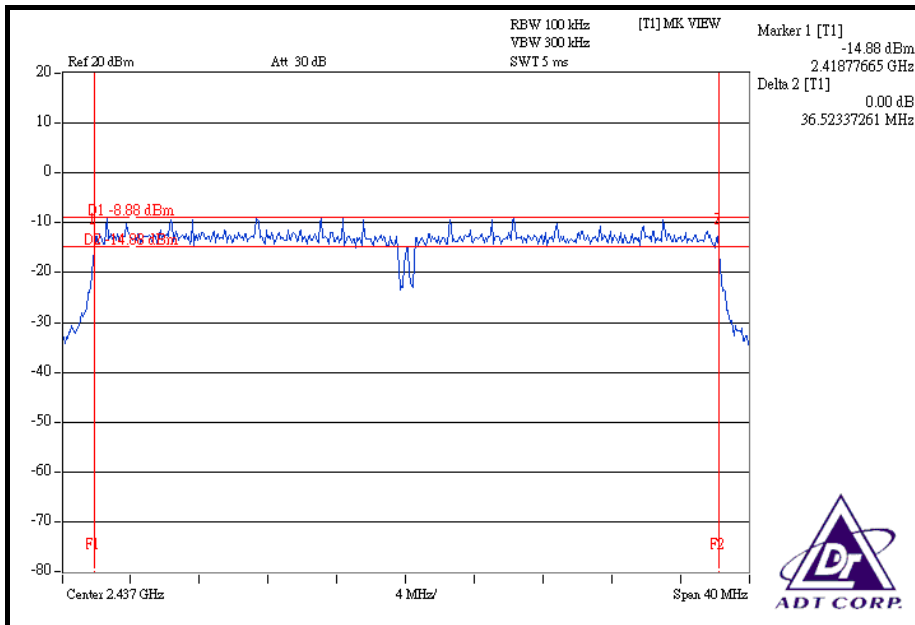

### CH 7

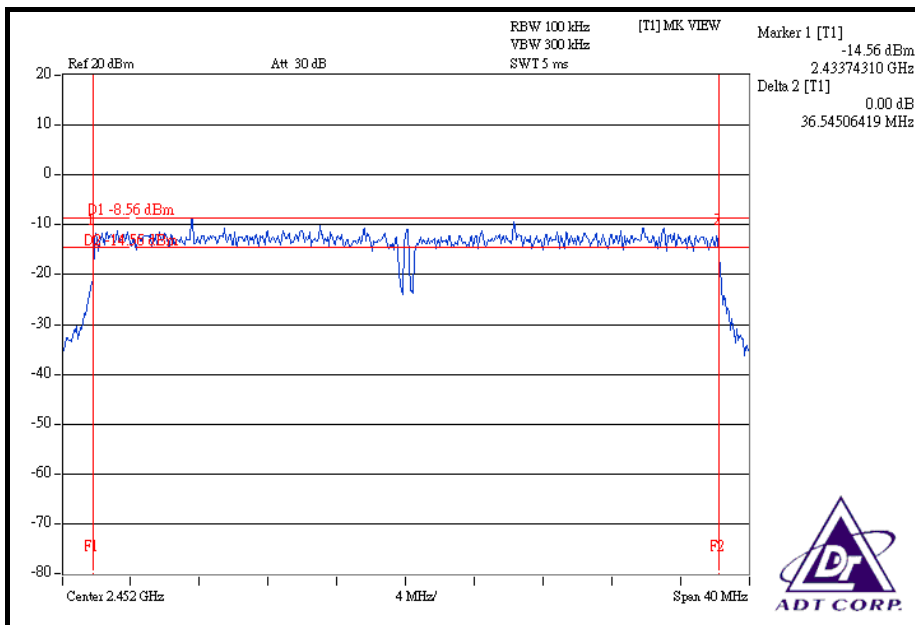



#### 4.4 MAXIMUM PEAK OUTPUT POWER

##### 4.4.1 LIMITS OF MAXIMUM PEAK OUTPUT POWER MEASUREMENT

The Maximum Peak Output Power Measurement is 30dBm.

##### 4.4.2 INSTRUMENTS

DESCRIPTION & MANUFACTURER	MODEL NO.	SERIAL NO.	CALIBRATED UNTIL
R&S SPECTRUM ANALYZER	FSP40	100040	Jun. 28, 2008
AGILENT SIGNAL GENERATOR	E8257C	MY43320668	Dec. 25, 2008
TEKTRONIX OSCILLOSCOPE	TDS1012	C037299	Nov. 21, 2008
NARDA DETECTOR	4503A	FSCM99899	NA

**NOTE:** The calibration interval of the above test instruments is 12 months and the calibrations are traceable to NML/ROC and NIST/USA.

##### 4.4.3 TEST PROCEDURES

- a. A detector was used on the output port of the EUT. An oscilloscope was used to read the response of the detector.
- b. Replaced the EUT by the signal generator. The center frequency of the S.G was adjusted to the center frequency of the measured channel.
- c. Adjusted the power to have the same reading on oscilloscope. Record the power level.

##### 4.4.4 DEVIATION FROM TEST STANDARD

No deviation

#### 4.4.5 TEST SETUP



#### 4.4.6 EUT OPERATING CONDITIONS

Same as Item 4.3.6



#### 4.4.7 TEST RESULTS

##### 802.11b DSSS MODULATION

<b>MODULATION TYPE</b>	DBPSK	<b>ENVIRONMENTAL CONDITIONS</b>	25deg.C, 65% RH, 987hPa
<b>INPUT POWER</b>	120Vac, 60 Hz	<b>TESTED BY</b>	Brad Wu

CHANNEL	CHANNEL FREQUENCY (MHz)	PEAK POWER OUTPUT (mW)	PEAK POWER OUTPUT (dBm)	PEAK POWER LIMIT (dBm)	PASS/FAIL
1	2412	64.714	18.11	30	PASS
6	2437	63.973	18.06	30	PASS
11	2462	64.269	18.08	30	PASS

##### 802.11g OFDM MODULATION

<b>MODULATION TYPE</b>	BPSK	<b>ENVIRONMENTAL CONDITIONS</b>	25deg.C, 65% RH, 987hPa
<b>INPUT POWER</b>	120Vac, 60 Hz	<b>TESTED BY</b>	Brad Wu

CHANNEL	CHANNEL FREQUENCY (MHz)	PEAK POWER OUTPUT (mW)	PEAK POWER OUTPUT (dBm)	PEAK POWER LIMIT (dBm)	PASS/FAIL
1	2412	63.533	18.03	30	PASS
6	2437	64.269	18.08	30	PASS
11	2462	51.168	17.09	30	PASS



**DRAFT 802.11n (20MHz) OFDM MODULATION**

<b>MODULATION TYPE</b>	BPSK	<b>ENVIRONMENTAL CONDITIONS</b>	25deg.C, 65% RH, 987hPa
<b>INPUT POWER</b>	120Vac, 60 Hz	<b>TESTED BY</b>	Brad Wu

CHAN.	CHANNEL FREQUENCY (MHz)	PEAK POWER OUTPUT (mW)			PEAK POWER OUTPUT (dBm)			TOTAL PEAK POWER (mW)	TOTAL PEAK POWER (dBm)	PEAK POWER LIMIT (dBm)	PASS / FAIL
		CHAIN0	CHAIN1	CHAIN2	CHAIN0	CHAIN1	CHAIN2				
1	2412	25.704	22.803	28.314	14.10	13.58	14.52	76.821	18.85	30	PASS
6	2437	22.387	25.645	25.235	13.50	14.09	14.02	73.267	18.65	30	PASS
11	2462	25.468	25.527	25.586	14.06	14.07	14.08	76.581	18.84	30	PASS

**DRAFT 802.11n (40MHz) OFDM MODULATION**

<b>MODULATION TYPE</b>	BPSK	<b>ENVIRONMENTAL CONDITIONS</b>	25deg.C, 65% RH, 987hPa
<b>INPUT POWER</b>	120Vac, 60 Hz	<b>TESTED BY</b>	Brad Wu

CHAN.	CHANNEL FREQUENCY (MHz)	PEAK POWER OUTPUT (mW)			PEAK POWER OUTPUT (dBm)			TOTAL PEAK POWER (mW)	TOTAL PEAK POWER (dBm)	PEAK POWER LIMIT (dBm)	PASS / FAIL
		CHAIN0	CHAIN1	CHAIN2	CHAIN0	CHAIN1	CHAIN2				
1	2422	10.162	10.186	12.764	10.07	10.08	11.06	33.112	15.20	30	PASS
4	2437	11.246	12.735	12.882	10.51	11.05	11.10	36.863	15.67	30	PASS
7	2452	11.455	12.853	14.388	10.59	11.09	11.58	38.696	15.88	30	PASS



## 4.5 POWER SPECTRAL DENSITY MEASUREMENT

### 4.5.1 LIMITS OF POWER SPECTRAL DENSITY MEASUREMENT

The Maximum of Power Spectral Density Measurement is 8dBm.

### 4.5.2 TEST INSTRUMENTS

DESCRIPTION & MANUFACTURER	MODEL NO.	SERIAL NO.	CALIBRATED UNTIL
SPECTRUM ANALYZER	FSP40	100040	Jun. 28, 2008

**NOTE:** The calibration interval of the above test instruments is 12 months and the calibrations are traceable to NML/ROC and NIST/USA.

### 4.5.3 TEST PROCEDURE

The transmitter output was connected to the spectrum analyzer through an attenuator, the bandwidth of the fundamental frequency was measured with the spectrum analyzer using 3kHz RBW and 30kHz VBW, set sweep time = span/3kHz. The power spectral density was measured and recorded.

The sweep time is allowed to be longer than span/3kHz for a full response of the mixer in the spectrum analyzer.

### 4.5.4 DEVIATION FROM TEST STANDARD

No deviation

#### 4.5.5 TEST SETUP

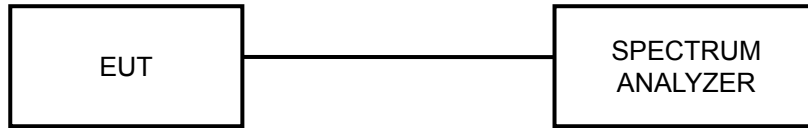

#### 4.5.6 EUT OPERATING CONDITION

Same as Item 4.3.6

## 4.5.7 TEST RESULTS

### 802.11b DSSS MODULATION

<b>MODULATION TYPE</b>	DBPSK	<b>ENVIRONMENTAL CONDITIONS</b>	25deg.C, 65% RH, 987hPa
<b>INPUT POWER</b>	120Vac, 60 Hz	<b>TESTED BY</b>	Brad Wu

CHANNEL	CHANNEL FREQUENCY (MHz)	RF POWER LEVEL IN 3kHz BW (dBm)	MAXIMUM LIMIT (dBm)	PASS/FAIL
1	2412	-8.54	8	PASS
6	2437	-8.64	8	PASS
11	2462	-8.40	8	PASS

### CH 1

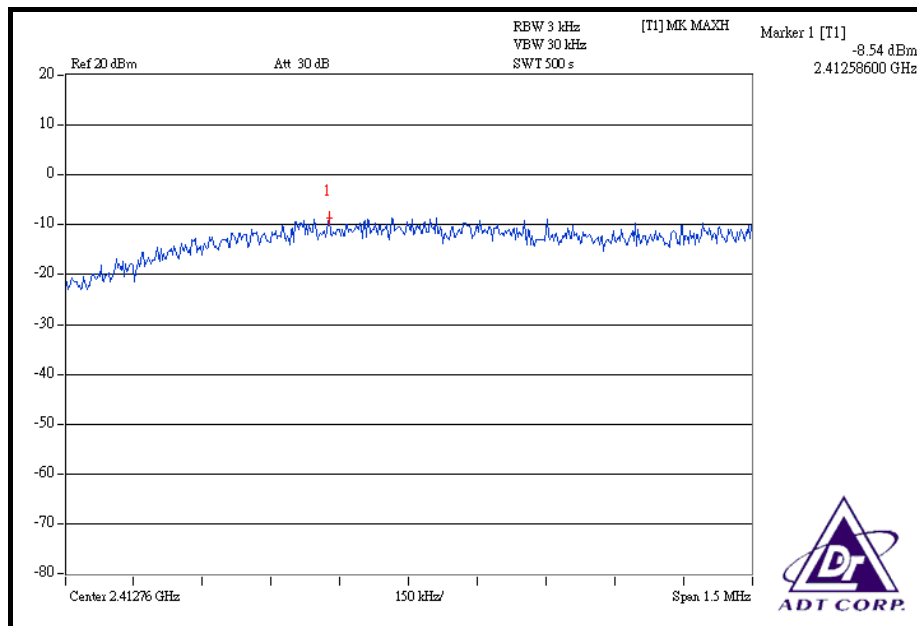



### CH 6

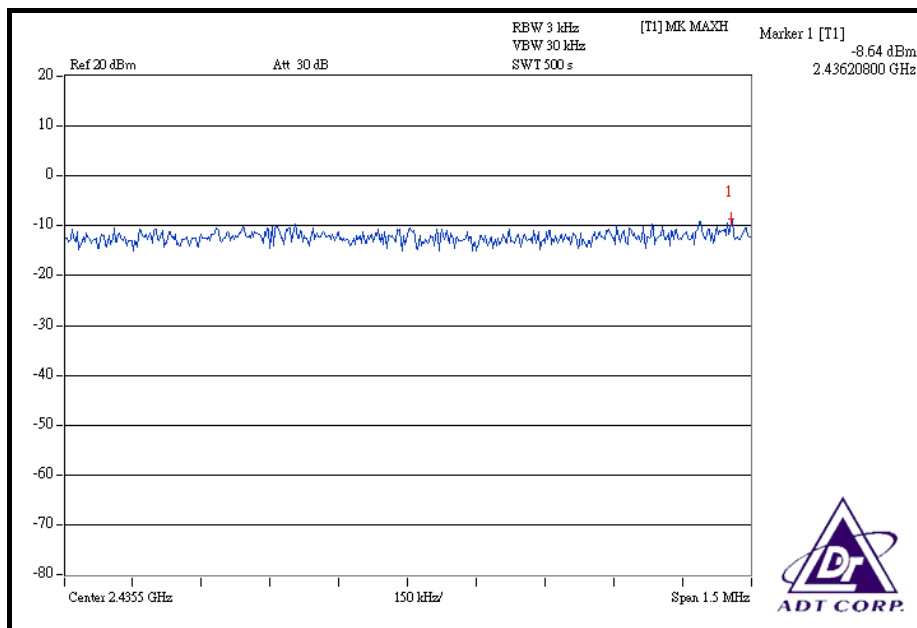

### CH 11

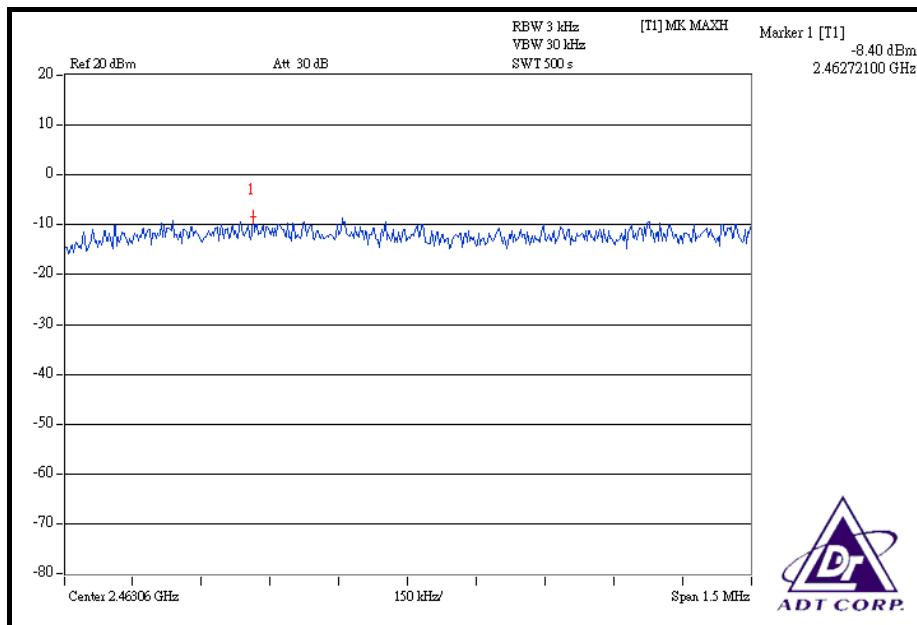



### 802.11g OFDM MODULATION

<b>MODULATION TYPE</b>	BPSK	<b>ENVIRONMENTAL CONDITIONS</b>	25deg.C, 65% RH, 987hPa
<b>INPUT POWER</b>	120Vac, 60 Hz	<b>TESTED BY</b>	Brad Wu

CHANNEL	CHANNEL FREQUENCY (MHz)	RF POWER LEVEL IN 3kHz BW (dBm)	MAXIMUM LIMIT (dBm)	PASS/FAIL
1	2412	-12.68	8	PASS
6	2437	-12.76	8	PASS
11	2462	-13.56	8	PASS

### CH 1

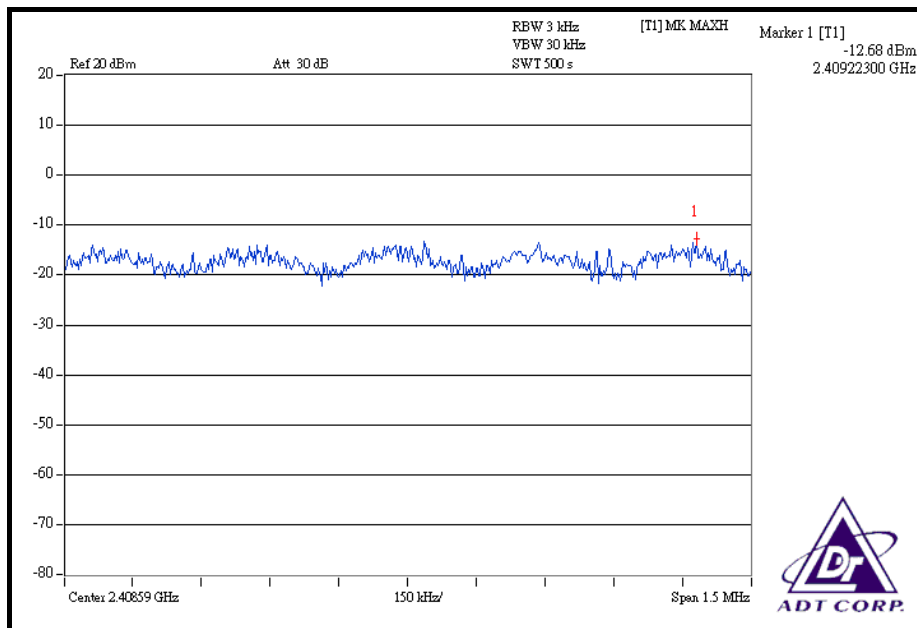

### CH 6

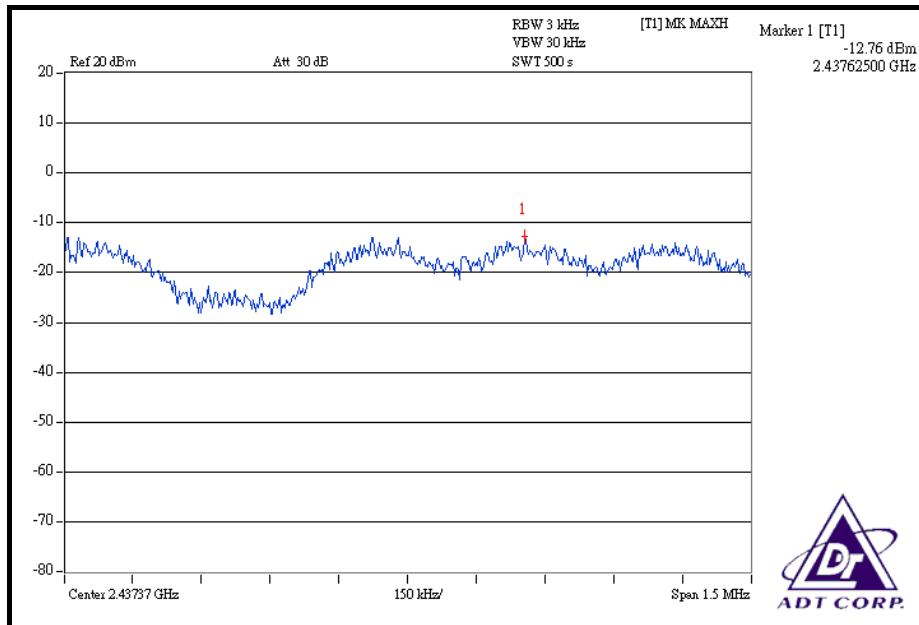

### CH 11

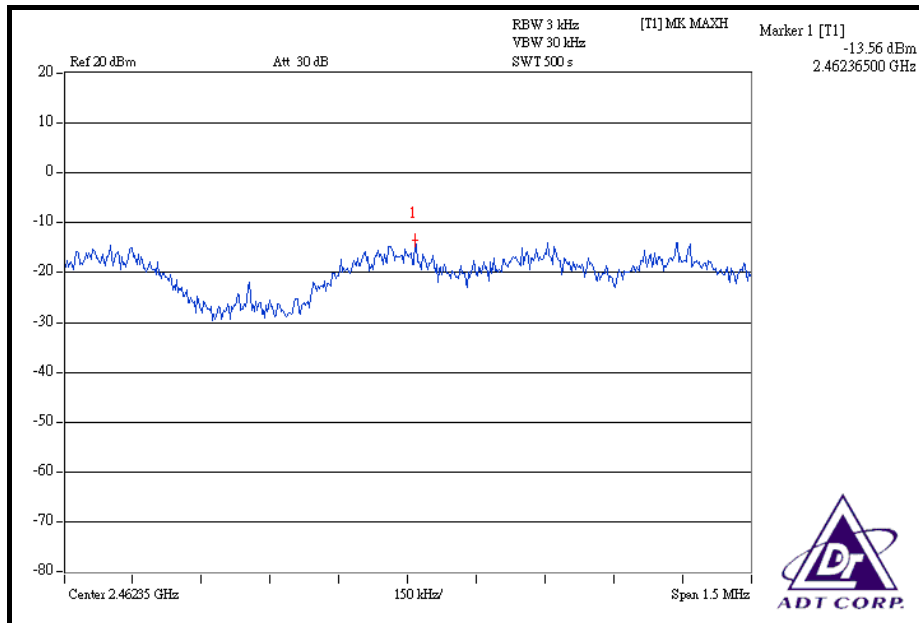



**DRAFT 802.11n (20MHz) OFDM MODULATION**

<b>MODULATION TYPE</b>	BPSK	<b>ENVIRONMENTAL CONDITIONS</b>	25deg.C, 65% RH, 987hPa
<b>INPUT POWER</b>	120Vac, 60 Hz	<b>TESTED BY</b>	Brad Wu

CHANNEL	CHANNEL FREQUENCY (MHz)	RF POWER LEVEL IN 3kHz BW (mW)			RF POWER LEVEL IN 3kHz BW (dBm)			TOTAL POWER DENSITY (mW)	TOTAL POWER DENSITY (dBm)	MAX. LIMIT (dBm)	PASS / FAIL
		CHAIN0	CHAIN1	CHAIN2	CHAIN0	CHAIN1	CHAIN2				
1	2412	0.020	0.031	0.030	-17.00	-15.09	-15.22	0.081	-10.92	8	PASS
6	2437	0.018	0.028	0.027	-17.40	-15.51	-15.61	0.073	-11.37	8	PASS
11	2462	0.018	0.027	0.028	-17.43	-15.73	-15.59	0.073	-11.37	8	PASS

**FOR CHAIN 0: CH 1**

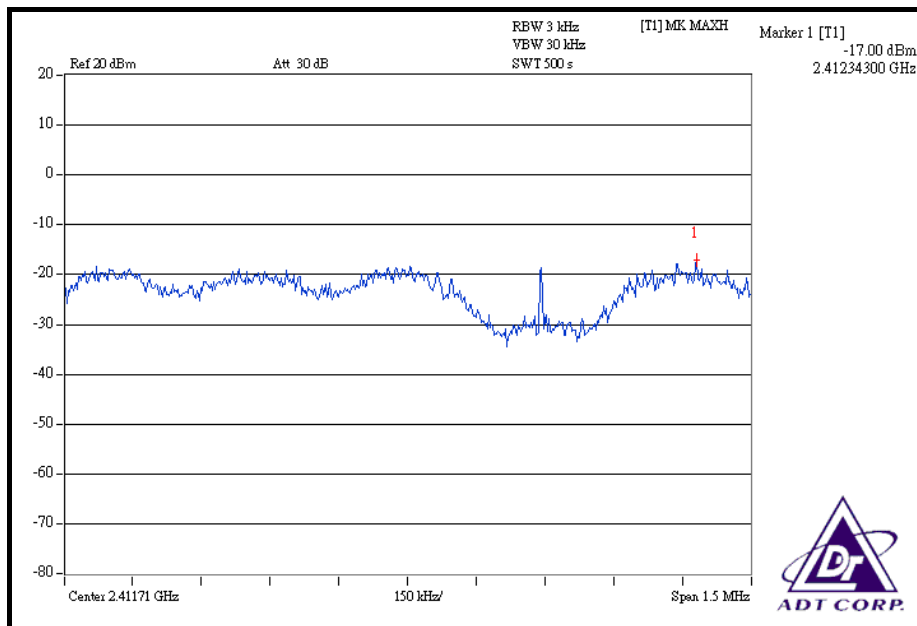

### CH 6

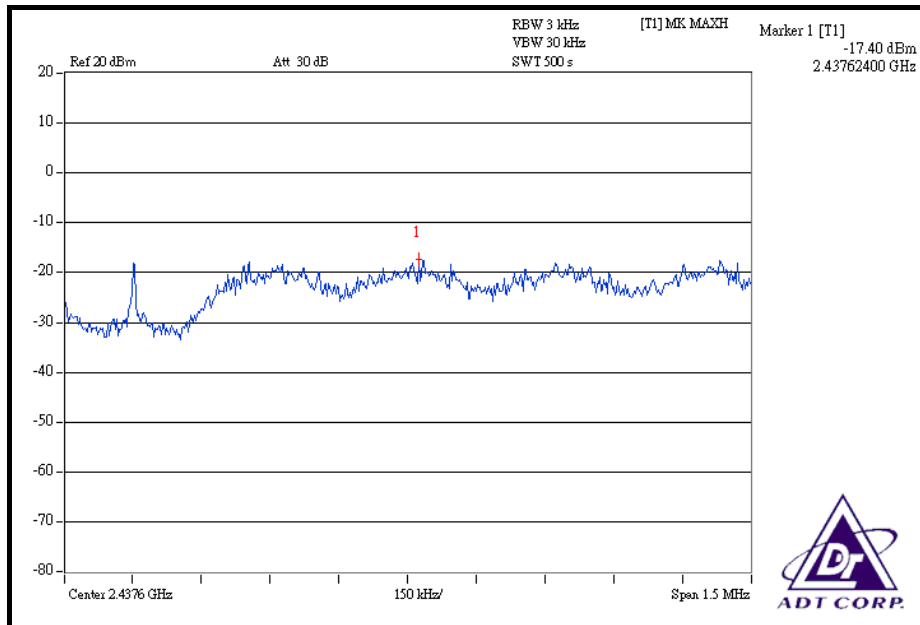

### CH 11

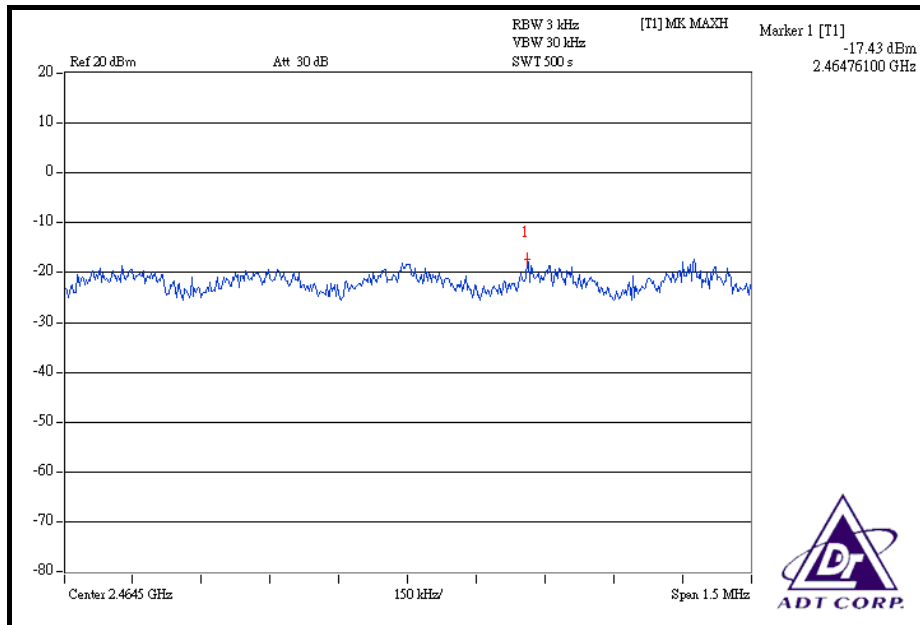

**FOR CHAIN 1: CH 1**

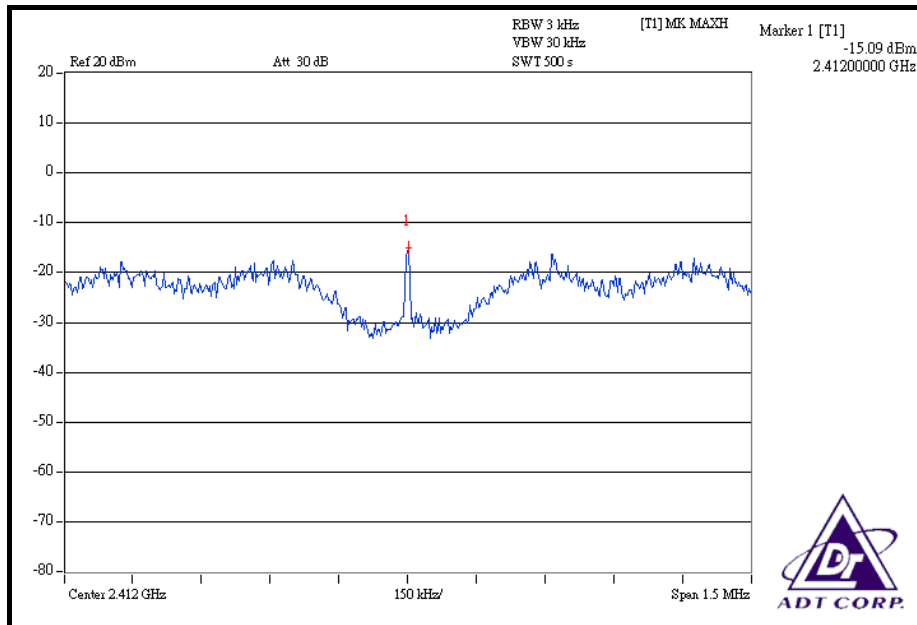

**CH 6**

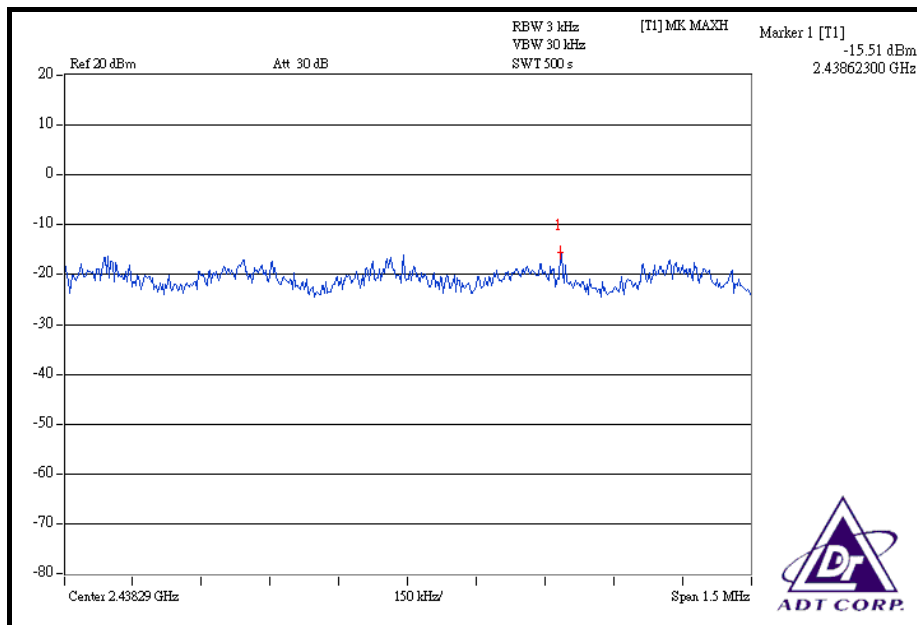

### CH 11

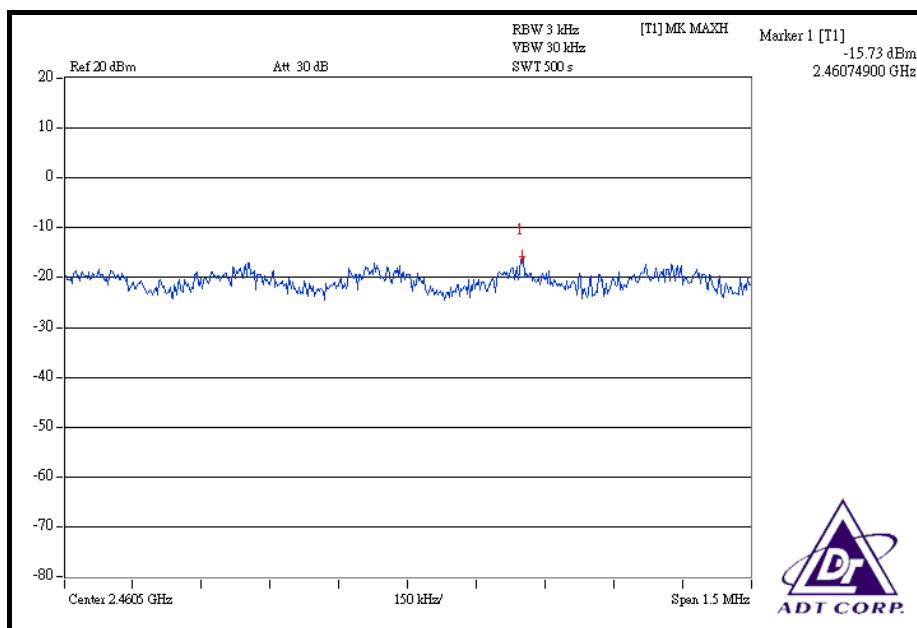

### FOR CHAIN 2: CH 1

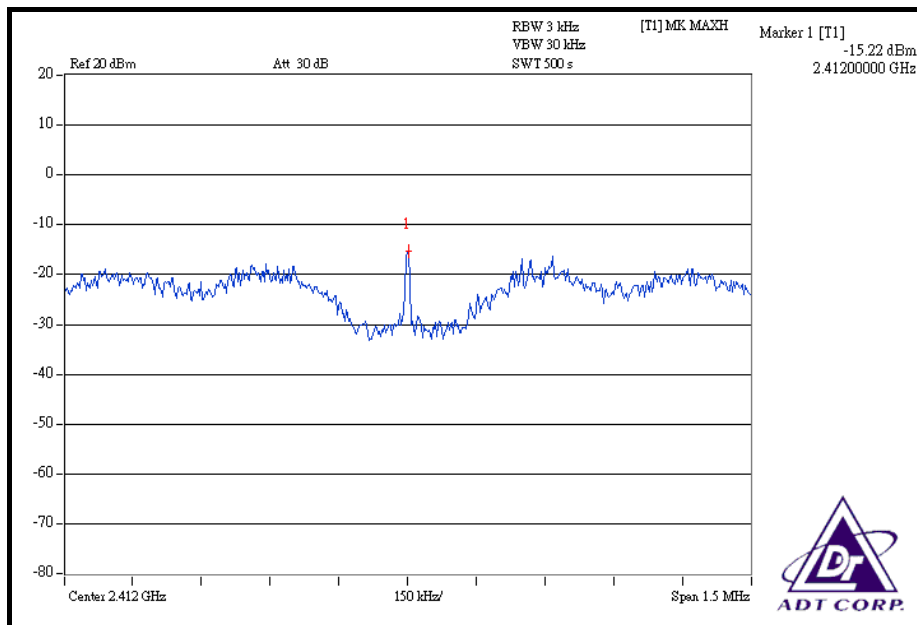

### CH 6

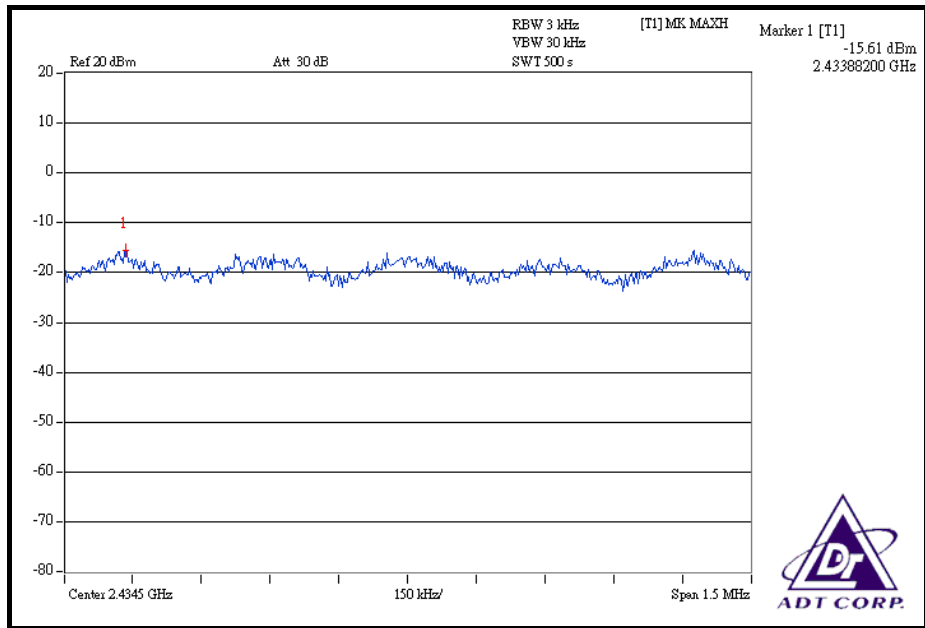

### CH 11

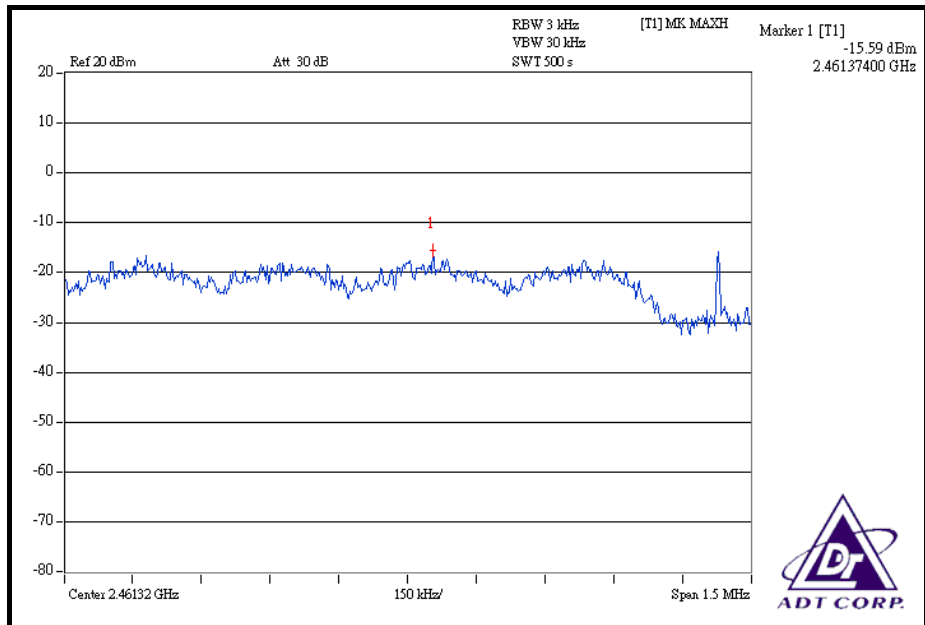





**DRAFT 802.11n (40MHz) OFDM MODULATION**

<b>MODULATION TYPE</b>	BPSK	<b>ENVIRONMENTAL CONDITIONS</b>	25deg.C, 65% RH, 987hPa
<b>INPUT POWER</b>	120Vac, 60 Hz	<b>TESTED BY</b>	Brad Wu

CHANNEL	CHANNEL FREQUENCY (MHz)	RF POWER LEVEL IN 3kHz BW (mW)			RF POWER LEVEL IN 3kHz BW (dBm)			TOTAL POWER DENSITY (mW)	TOTAL POWER DENSITY (dBm)	MAX. LIMIT (dBm)	PASS / FAIL
		CHAIN0	CHAIN1	CHAIN2	CHAIN0	CHAIN1	CHAIN2				
1	2422	0.007	0.010	0.010	-21.43	-20.14	-19.93	0.027	-15.68	8	PASS
4	2437	0.007	0.010	0.011	-21.57	-19.95	-19.74	0.028	-15.58	8	PASS
7	2452	0.008	0.011	0.012	-20.76	-19.58	-19.30	0.031	-15.06	8	PASS

**FOR CHAIN 0: CH 1**

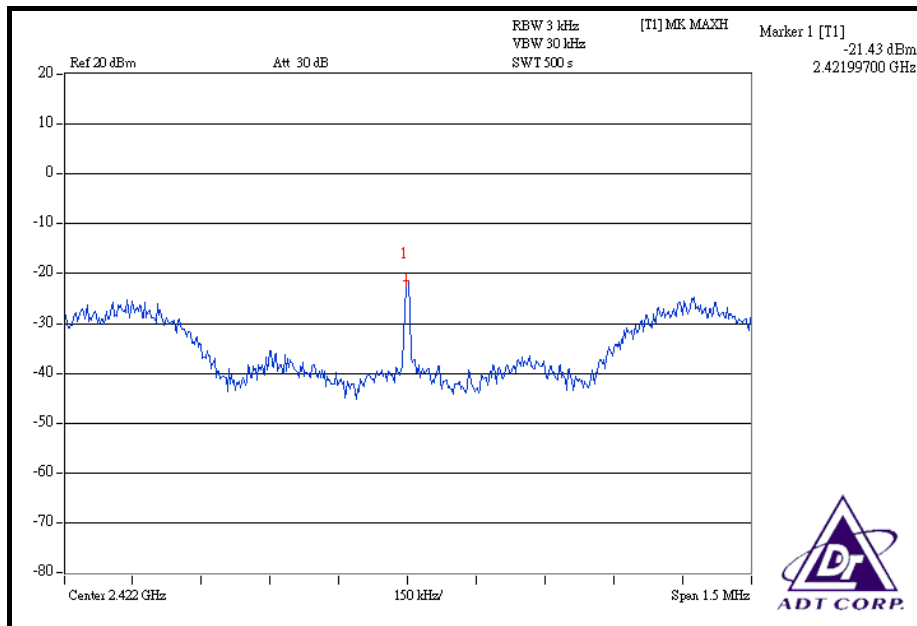

### CH 4

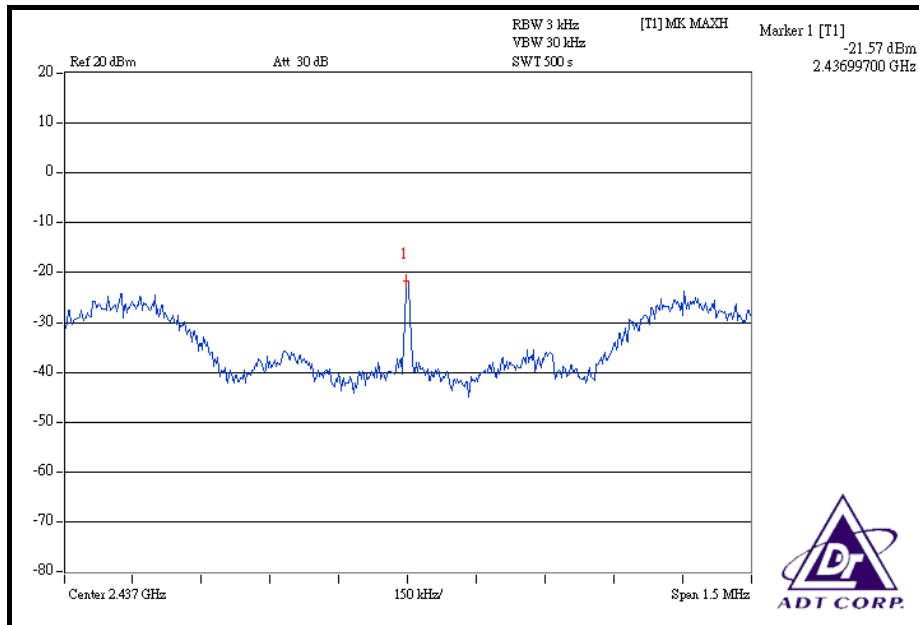

### CH 7

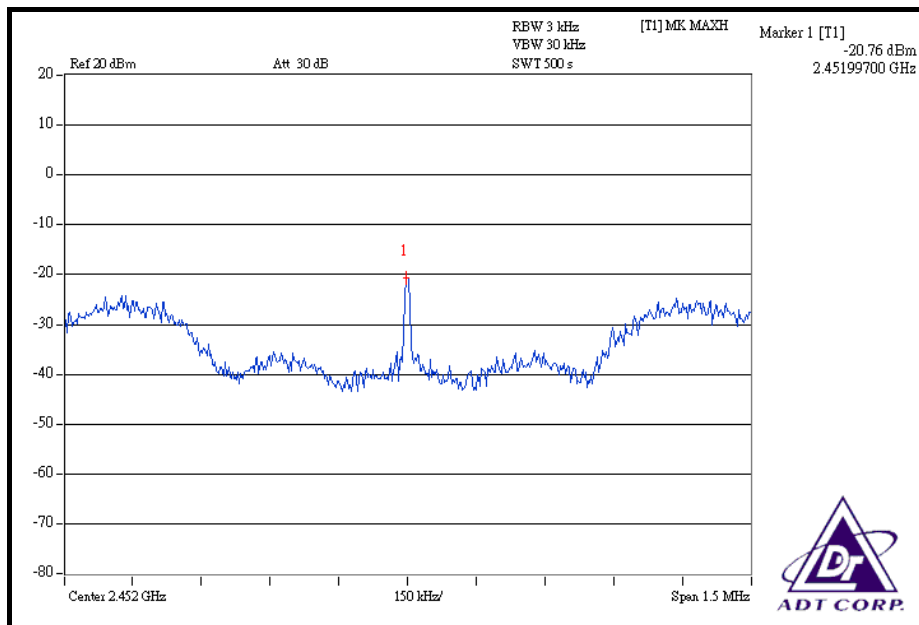

### FOR CHAIN 1: CH 1

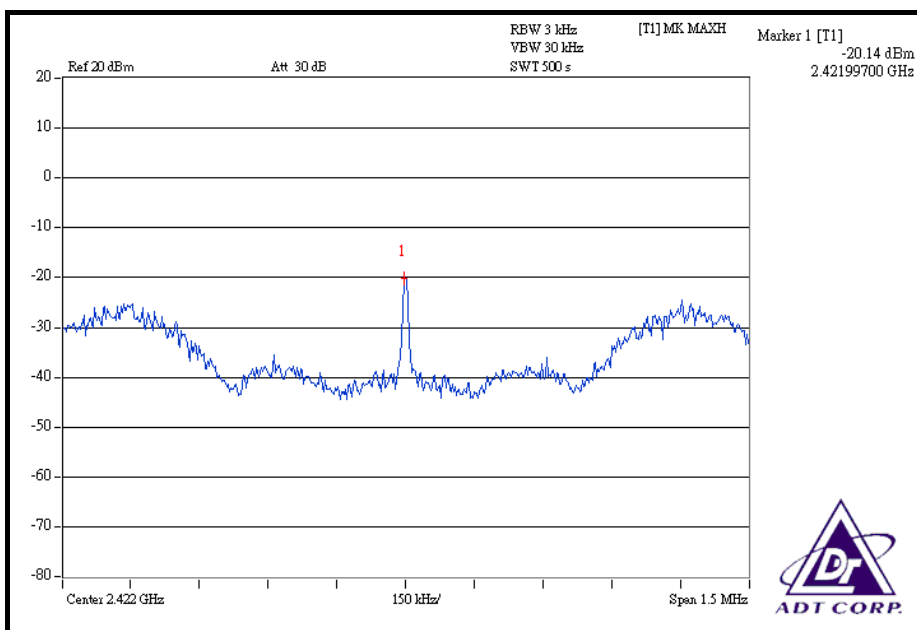

### CH 4

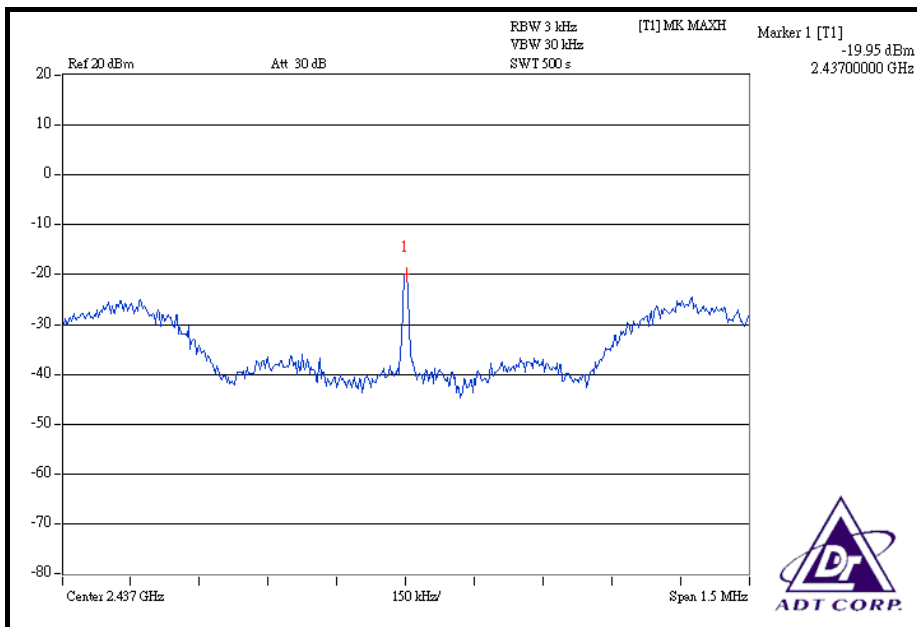

### CH 7

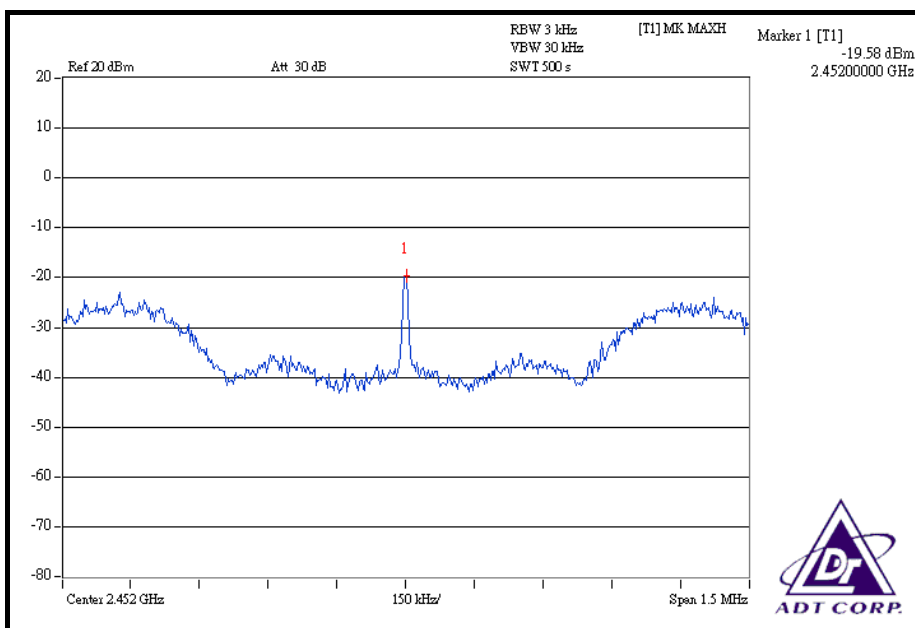

### FOR CHAIN 2: CH 1

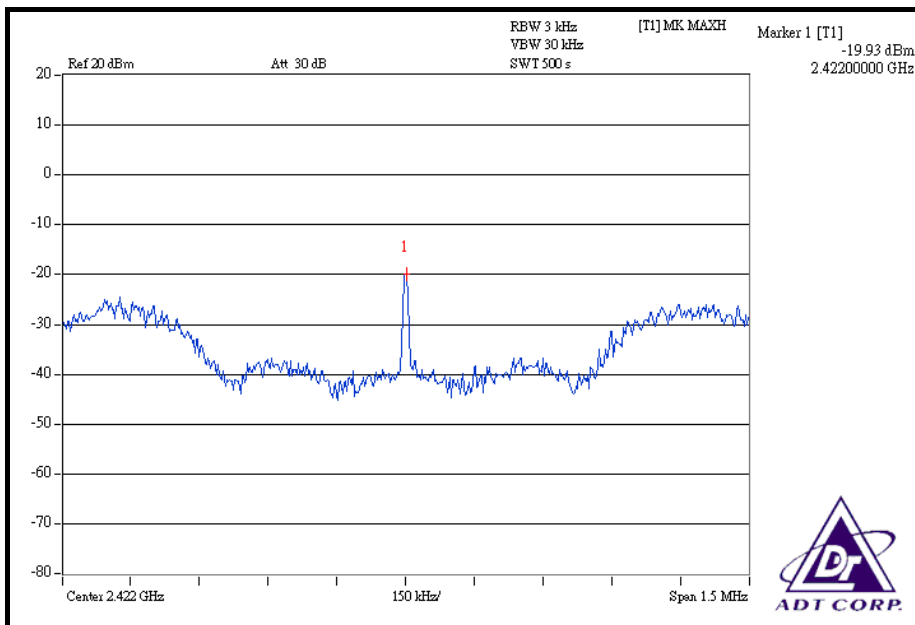



#### CH 4

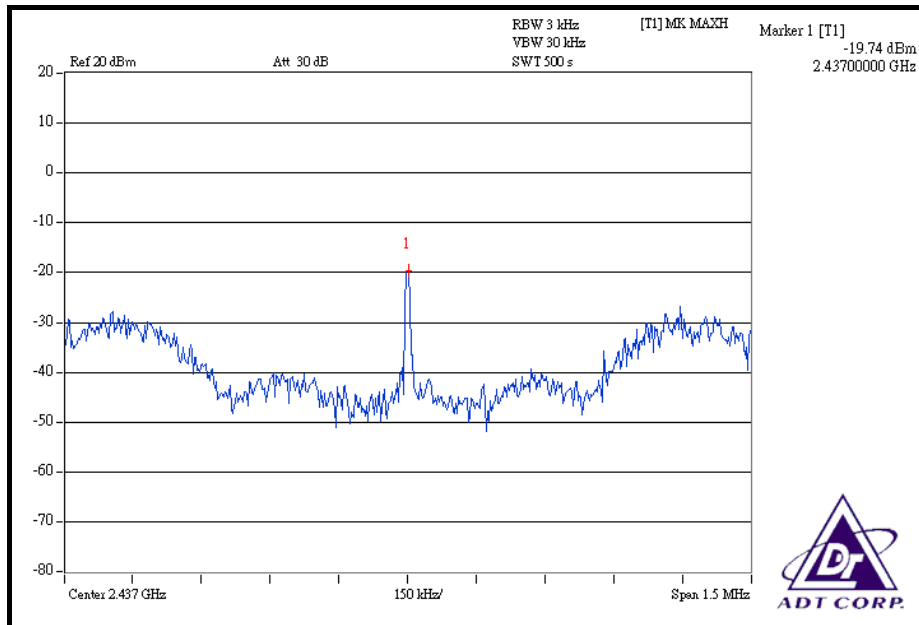

#### CH 7

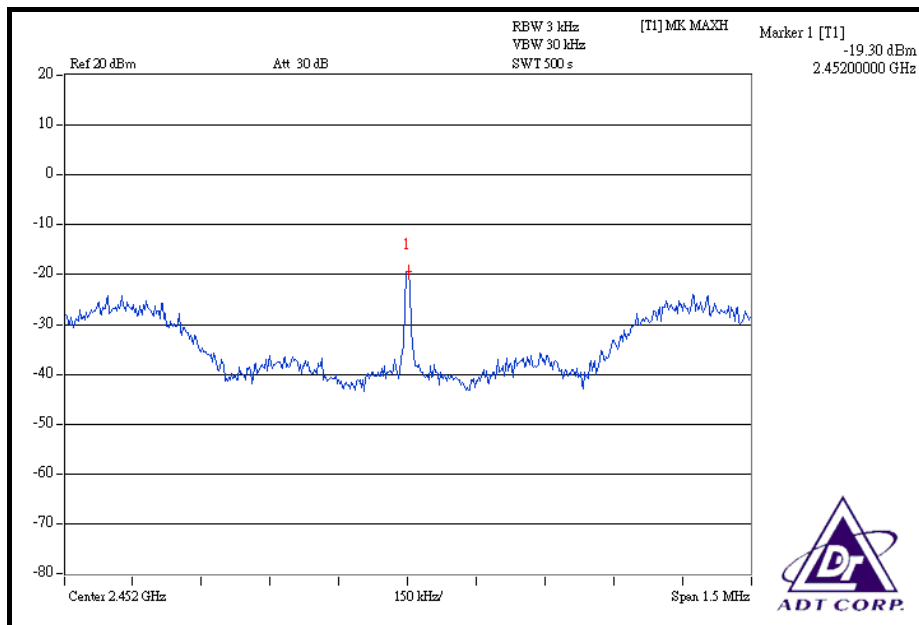



## 4.6 BAND EDGES MEASUREMENT

### 4.6.1 LIMITS OF BAND EDGES MEASUREMENT

Below -20dB of the highest emission level of operating band (in 100kHz Resolution Bandwidth).

### 4.6.2 TEST INSTRUMENTS

DESCRIPTION & MANUFACTURER	MODEL NO.	SERIAL NO.	CALIBRATED UNTIL
<b>For 802.11b, 802.11g:</b>			
R&S SPECTRUM ANALYZER	FSP40	100040	Jun. 28, 2008
<b>For Draft 802.11n:</b>			
Test Receiver ROHDE & SCHWARZ	ESCI	100424	Jul. 27, 2008
Spectrum Analyzer ROHDE & SCHWARZ	FSP40	100269	Aug. 05, 2008
BILOG Antenna SCHWARZBECK	VULB9168	9168-153	Jan. 03, 2009
HORN Antenna SCHWARZBECK	BBHA 9120 D	9120D-563	Jul. 30, 2008
HORN Antenna SCHWARZBECK	BBHA 9170	BBHA9170242	Jan. 16, 2008
Preamplifier Agilent	8449B	3008A01910	Sep. 19, 2008
Preamplifier Agilent	8447D	2944A10638	Dec. 19, 2008
RF signal cable HUBER+SUHNNER	SUCOFLEX 104	274039/223650	Nov. 07, 2008
RF signal cable Worken	8D-FB	Cable-HYCH9-01	Aug. 09, 2008
Software	ADT_Radiated_V7.6	NA	NA
Antenna Tower EMCO	2070/2080	512.835.4684	NA
Turn Table EMCO	2087-2.03	NA	NA
Antenna Tower & Turn Table Controller EMCO	2090	NA	NA

**NOTE:** The calibration interval of the above test instruments is 12 months and the calibrations are traceable to NML/ROC and NIST/USA.

### 4.6.3 TEST PROCEDURE

#### For 802.11b, 802.11g:

The transmitter output was connected to the spectrum analyzer via a low loss cable. Set both RBW and VBW of spectrum analyzer to 100kHz with suitable frequency span including 10Hz bandwidth from band edge. The band edges was measured and recorded.

The spectrum plots (Peak RBW = 100kHz, VBW = 300kHz; Average RBW = 1MHz, VBW = 10Hz) are attached on the following pages.

#### For Draft 802.11n:

- a. The EUT was placed on the top of a rotating table 0.8 meters above the ground at a 3 meter semi-anechoic chamber. The table was rotated 360 degrees to determine the position of the highest radiation.
- b. The EUT was set 3 meters away from the interference-receiving antenna, which was mounted on the top of a variable-height antenna tower.
- c. The antenna is a broadband antenna, and its height is varied from one meter to four meters above the ground to determine the maximum value of the field strength. Both horizontal and vertical polarizations of the antenna are set to make the measurement.
- d. For each suspected emission, the EUT was arranged to its worst case and then the antenna was tuned to heights from 1 meter to 4 meters and the rotatable table was turned from 0 degrees to 360 degrees to find the maximum reading.
- e. Set both RBW and VBW of spectrum analyzer to 100kHz with suitable frequency span including 100MHz bandwidth from band edge. The band edges was measured and recorded.

The spectrum plots (Peak RBW = 100kHz, VBW = 300kHz; Average RBW = 1MHz, VBW = 1kHz)

**NOTE:** The resolution bandwidth of test receiver/spectrum analyzer is 1 MHz and the video bandwidth is 10Hz(for 802.11b/g), 1kHz(for 802.11n) for Average detection (AV) at frequency above 1GHz.

### 4.6.4 DEVIATION FROM TEST STANDARD

No deviation

### 4.6.5 EUT OPERATING CONDITION

Same as Item 4.3.6

#### 4.6.6 TEST RESULTS

The spectrum plots are attached on the following 24 images. D1 line indicates the highest level, and D2 line indicates the 20dB offset below D1. It shows compliance with the requirement in part 15.247(d).

#### 802.11b DSSS MODULATION

**NOTE 1:**

The band edge emission plot on the next page shows 52.49dBc between carrier maximum power and local maximum emission in restrict band (2.38760GHz). The emission of carrier strength list in the test result of channel 1 at the item 4.2.7 is 109.83dBuV/m (Peak), so the maximum field strength in restrict band is  $109.83 - 52.49 = 57.34$ dBuV/m which is under 74dBuV/m limit.

The band edge emission plot of on the next page shows 56.49dBc between carrier maximum power and local maximum emission in restrict band (2.38620GHz). The emission of carrier strength list in the test result of channel 1 at the item 4.2.7 is 105.23dBuV/m (Average), so the maximum field strength in restrict band is  $105.23 - 56.49 = 48.74$ dBuV/m which is under 54dBuV/m limit.

**NOTE 2:**

The band edge emission plot on the next second page shows 53.31dBc between carrier maximum power and local maximum emission in restrict band (2.48800GHz). The emission of carrier strength list in the test result of channel 11 at the item 4.2.7 is 110.57dBuV/m (Peak), so the maximum field strength in restrict band is  $110.57 - 53.31 = 57.26$ dBuV/m which is under 74dBuV/m limit.

The band edge emission plot on the next third page shows 55.57dBc between carrier maximum power and local maximum emission in restrict band (2.48760GHz). The emission of carrier strength list in the test result of channel 11 at the item 4.2.7 is 105.97dBuV/m (Average), so the maximum field strength in restrict band is  $105.97 - 55.57 = 50.40$ dBuV/m which is under 54dBuV/m limit.



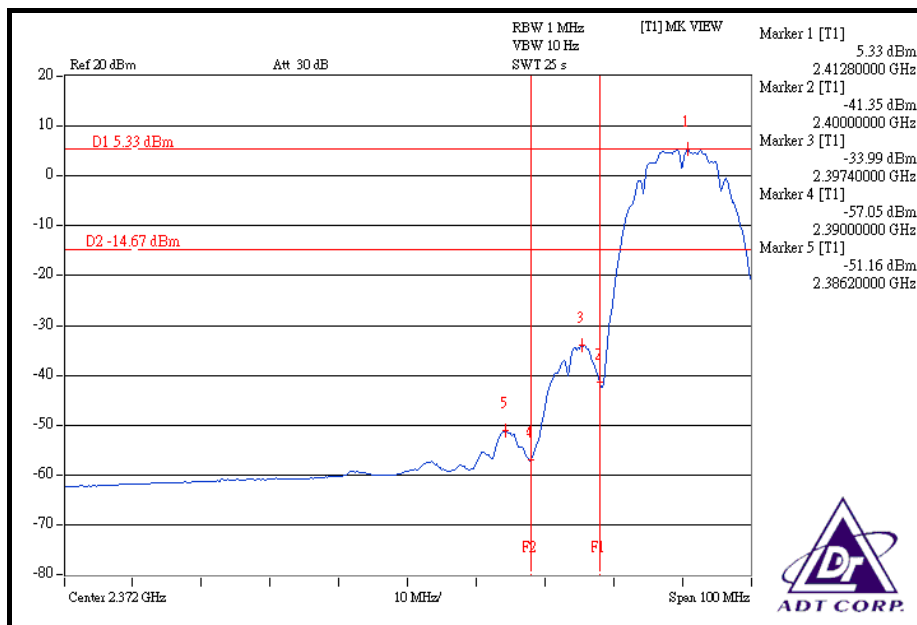
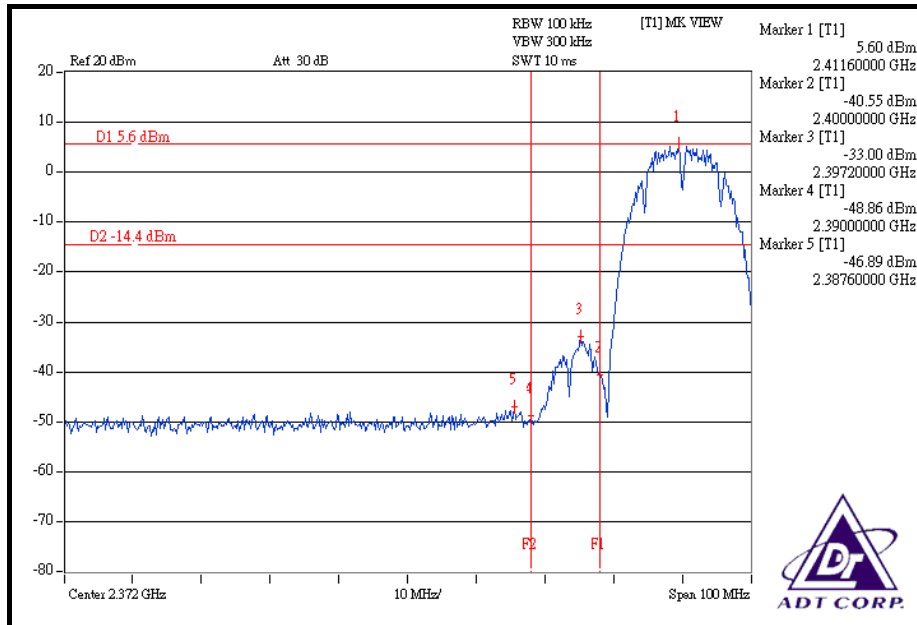

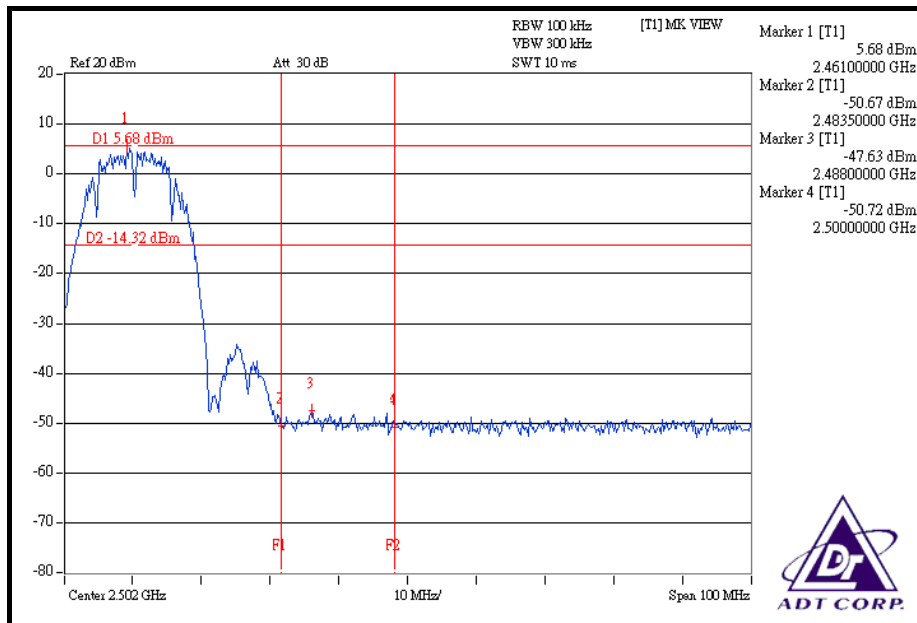
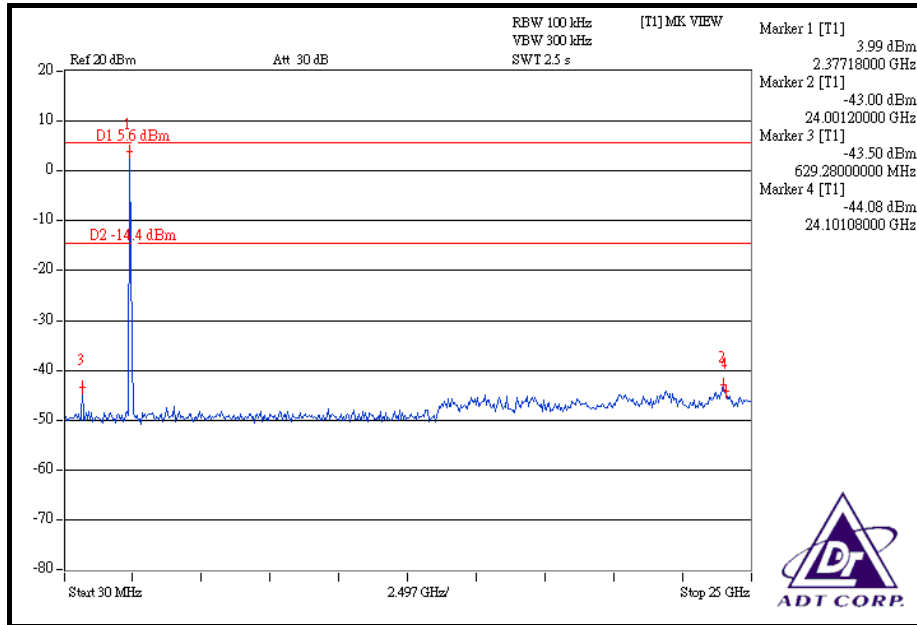

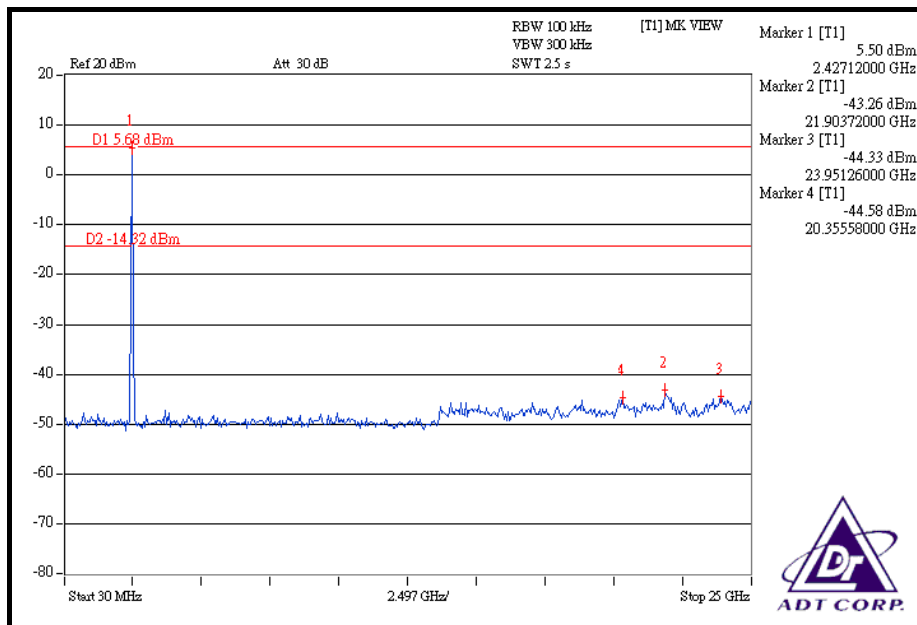
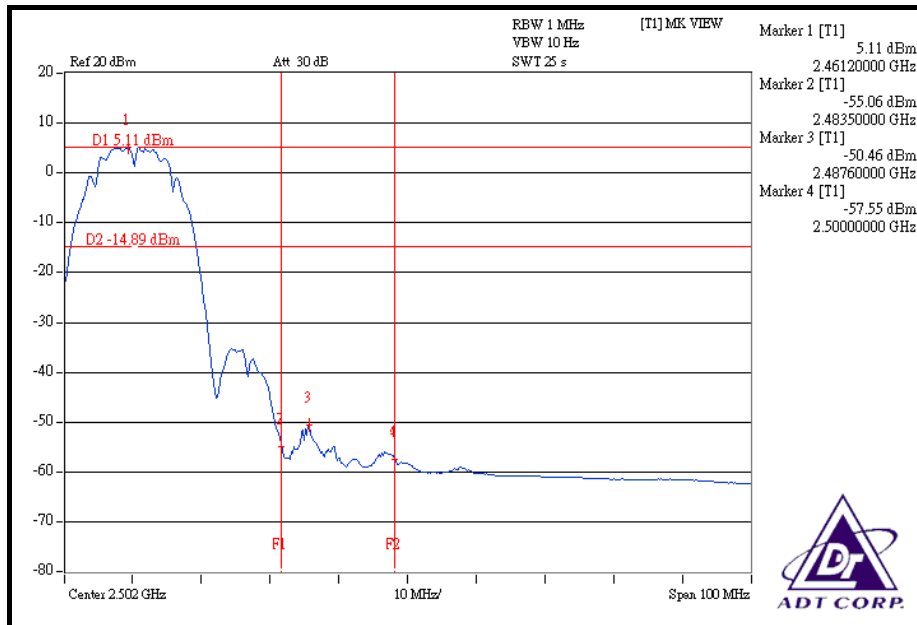

## 802.11g OFDM MODULATION

### NOTE 1:

The band edge emission plot on the next page shows 44.62dBc between carrier maximum power and local maximum emission in restrict band (2.38900GHz). The emission of carrier strength list in the test result of channel 1 at the item 4.2.7 is 111.45dBuV/m (Peak), so the maximum field strength in restrict band is  $111.45 - 44.62 = 66.83$ dBuV/m which is under 74dBuV/m limit.

The band edge emission plot of on the next page shows 47.68dBc between carrier maximum power and local maximum emission in restrict band (2.39000GHz). The emission of carrier strength list in the test result of channel 1 at the item 4.2.7 is 100.55dBuV/m (Average), so the maximum field strength in restrict band is  $100.55 - 47.68 = 52.87$ dBuV/m which is under 54dBuV/m limit.

### NOTE 2:

The band edge emission plot on the next second page shows 41.76dBc between carrier maximum power and local maximum emission in restrict band (2.48360GHz). The emission of carrier strength list in the test result of channel 11 at the item 4.2.7 is 110.82dBuV/m (Peak), so the maximum field strength in restrict band is  $110.82 - 41.76 = 69.06$ dBuV/m which is under 74dBuV/m limit.

The band edge emission plot on the next third page shows 46.63dBc between carrier maximum power and local maximum emission in restrict band (2.48350GHz). The emission of carrier strength list in the test result of channel 11 at the item 4.2.7 is 99.51dBuV/m (Average), so the maximum field strength in restrict band is  $99.51 - 46.63 = 52.88$ dBuV/m which is under 54dBuV/m limit.

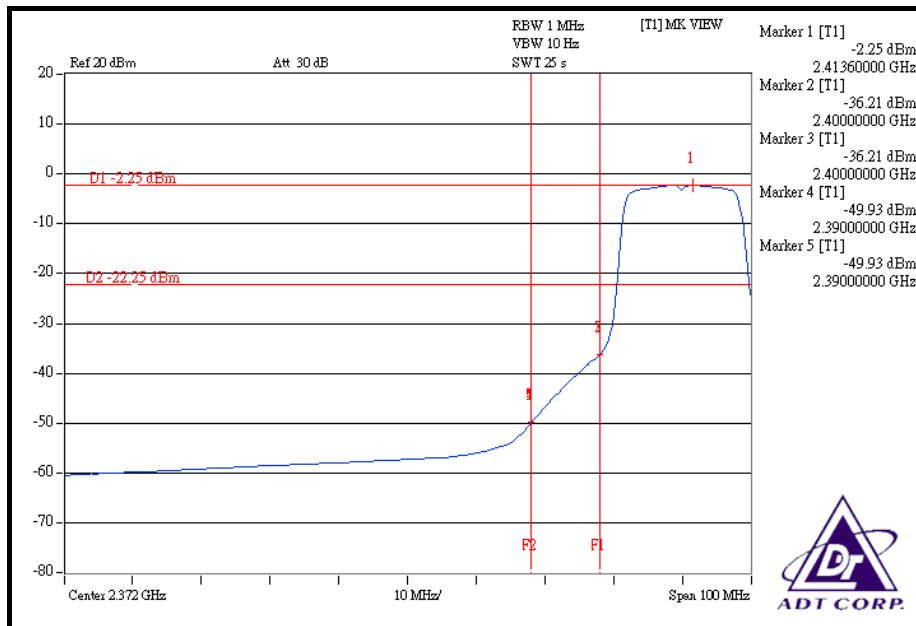
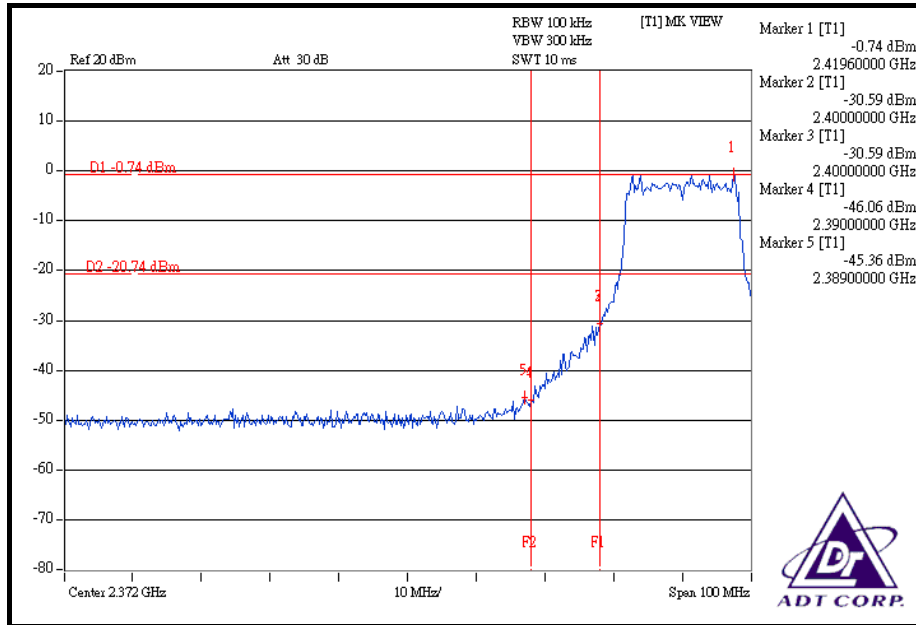

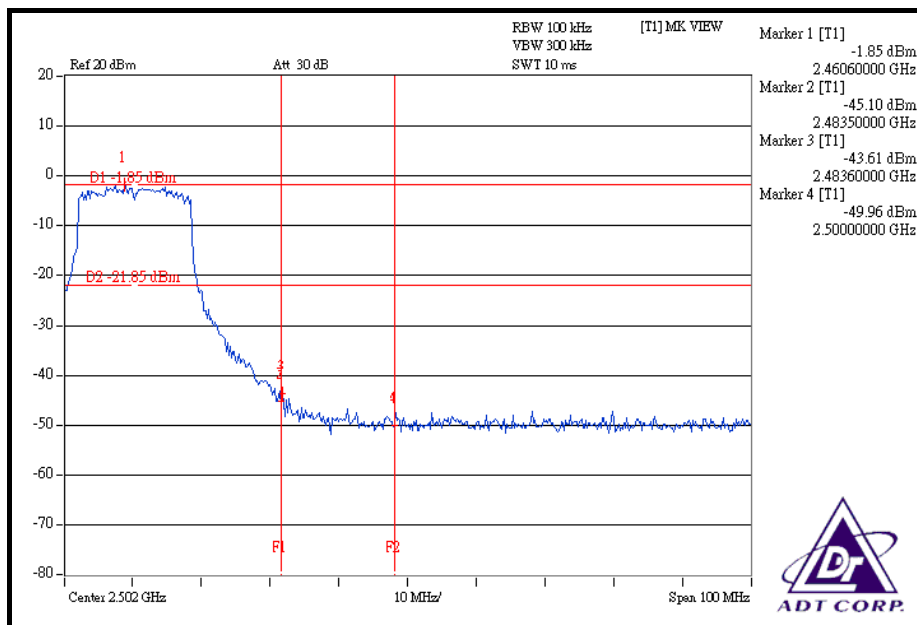
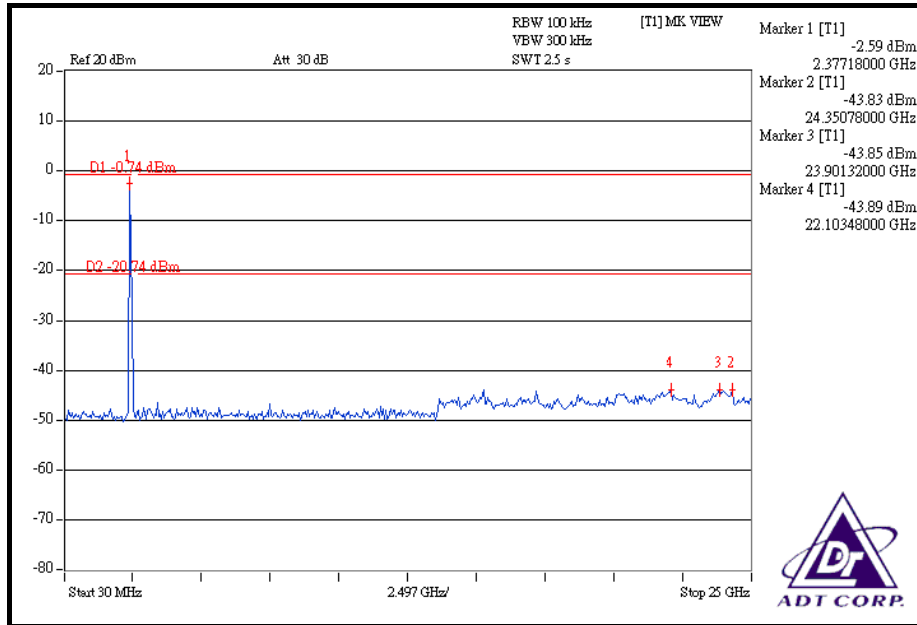

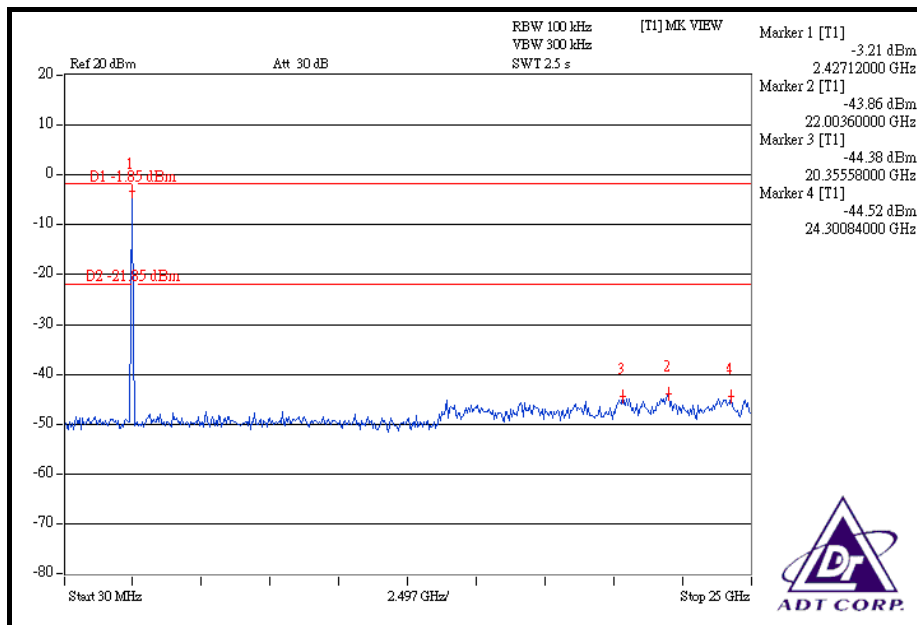
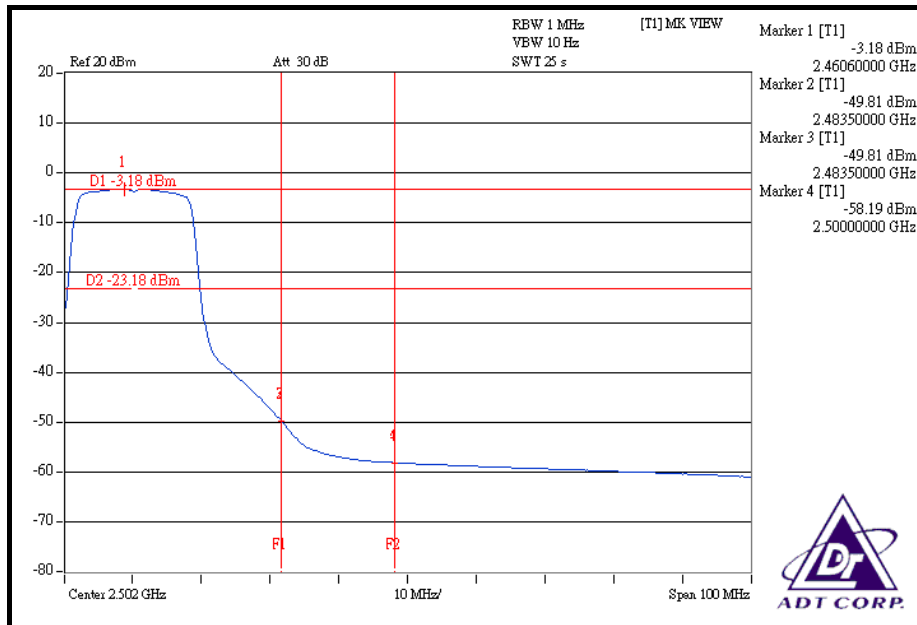

### **DRAFT 802.11n (20MHz) OFDM MODULATION:**

#### **NOTE 1:**

The band edge emission plot of OFDM technique on the next page shows 48.43dBc between carrier maximum power and local maximum emission in restrict band (2.38820GHz). The emission of carrier strength list in the test result of channel 1 at the item 4.2.7 is 111.60dBuV/m (Peak), so the maximum field strength in restrict band is  $111.60 - 48.43 = 63.17$ dBuV/m which is under 74dBuV/m limit.

The band edge emission plot of OFDM technique on the next page shows 50.52dBc between carrier maximum power and local maximum emission in restrict band (2.39000GHz). The emission of carrier strength list in the test result of channel 1 at the item 4.2.7 is 101.44dBuV/m (Average), so the maximum field strength in restrict band is  $101.44 - 50.52 = 50.92$ dBuV/m which is under 54dBuV/m limit.

#### **NOTE 2:**

The band edge emission plot of OFDM technique on the next second page shows 49.12dBc between carrier maximum power and local maximum emission in restrict band (2.48800GHz). The emission of carrier strength list in the test result of channel 11 at the item 4.2.7 is 112.85dBuV/m (Peak), so the maximum field strength in restrict band is  $112.85 - 49.12 = 63.73$ dBuV/m which is under 74dBuV/m limit.

The band edge emission plot of OFDM technique on the next third page shows 53.59dBc between carrier maximum power and local maximum emission in restrict band (2.48350GHz). The emission of carrier strength list in the test result of channel 11 at the item 4.2.7 is 103.38dBuV/m (Average), so the maximum field strength in restrict band is  $103.38 - 53.59 = 49.79$ dBuV/m which is under 54dBuV/m limit.



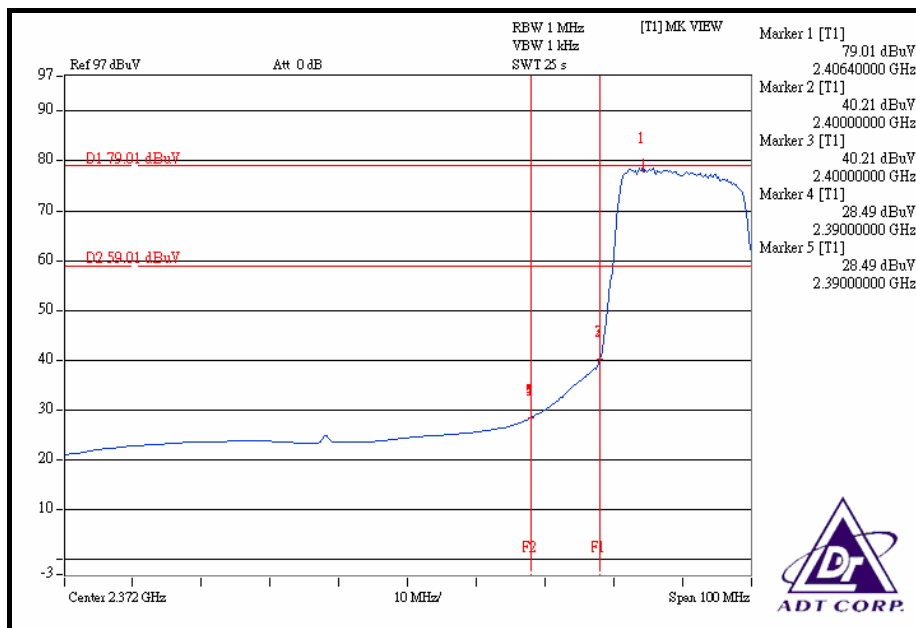
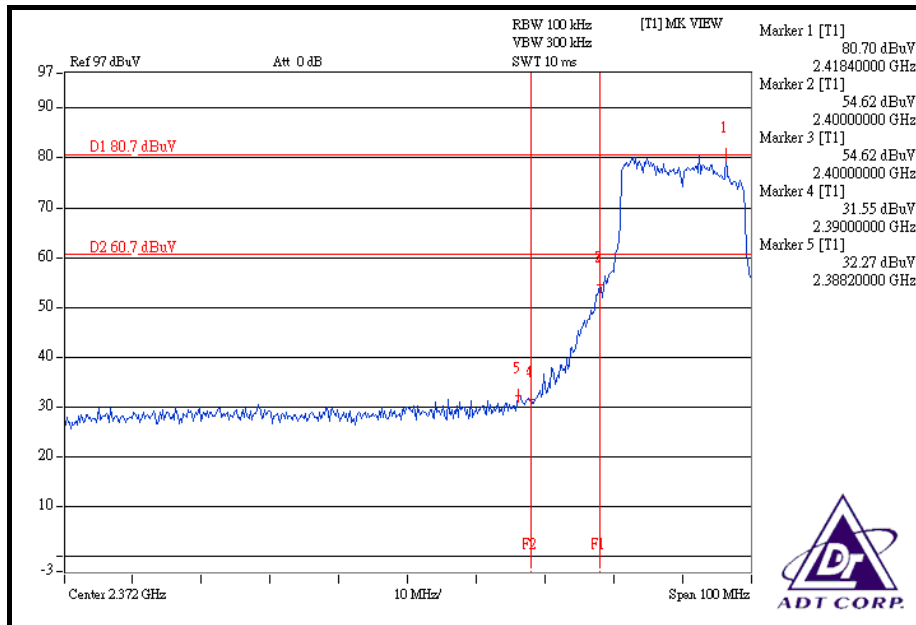

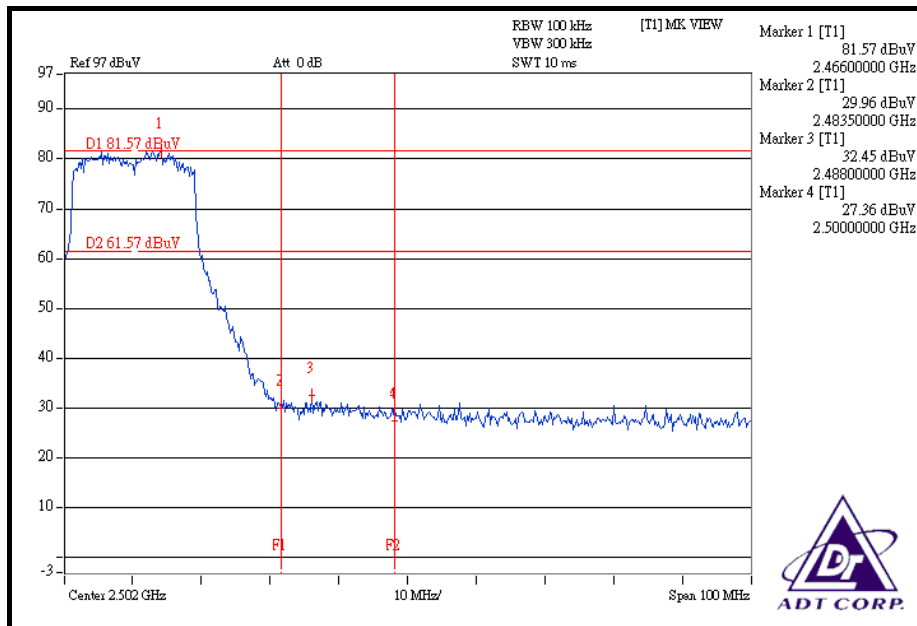
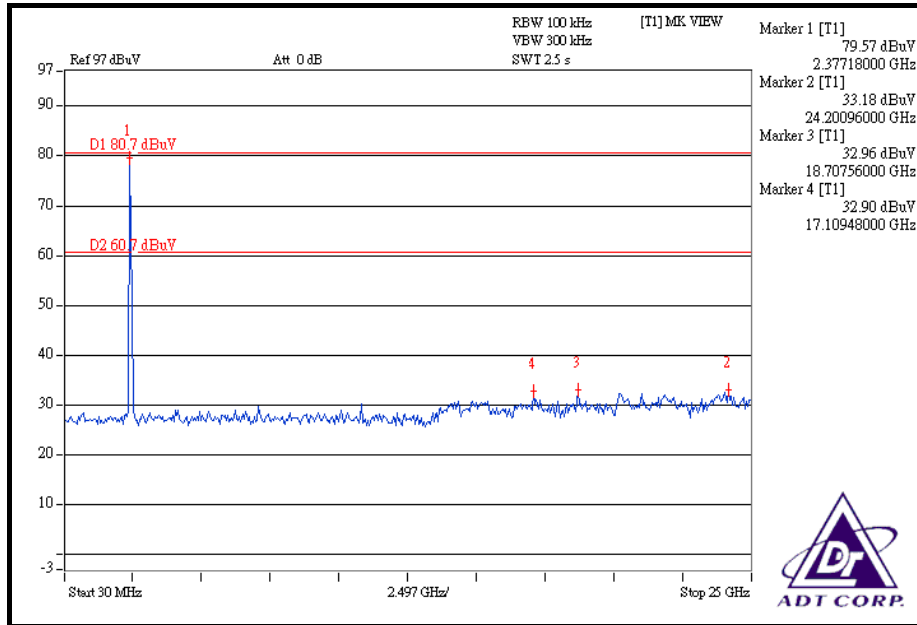

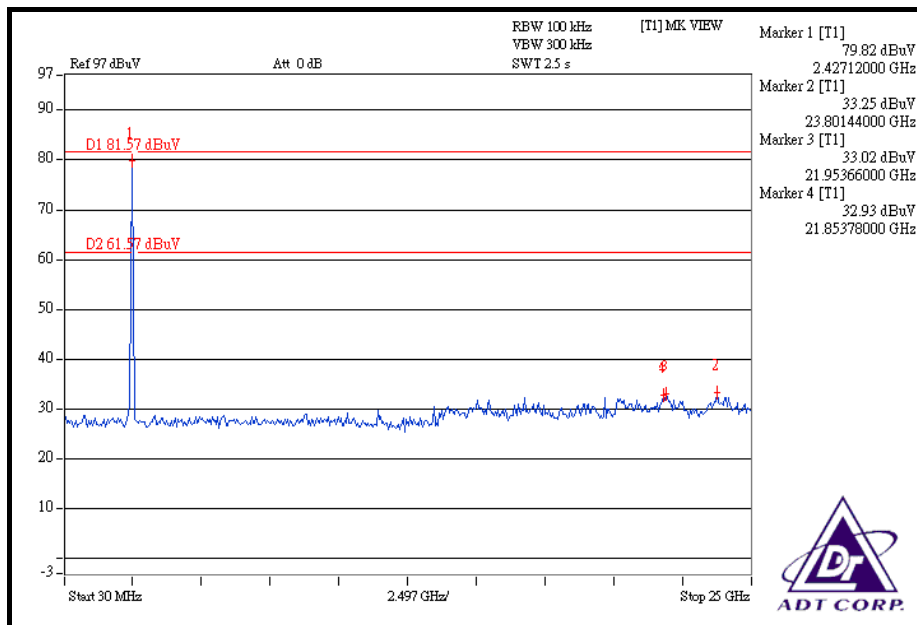
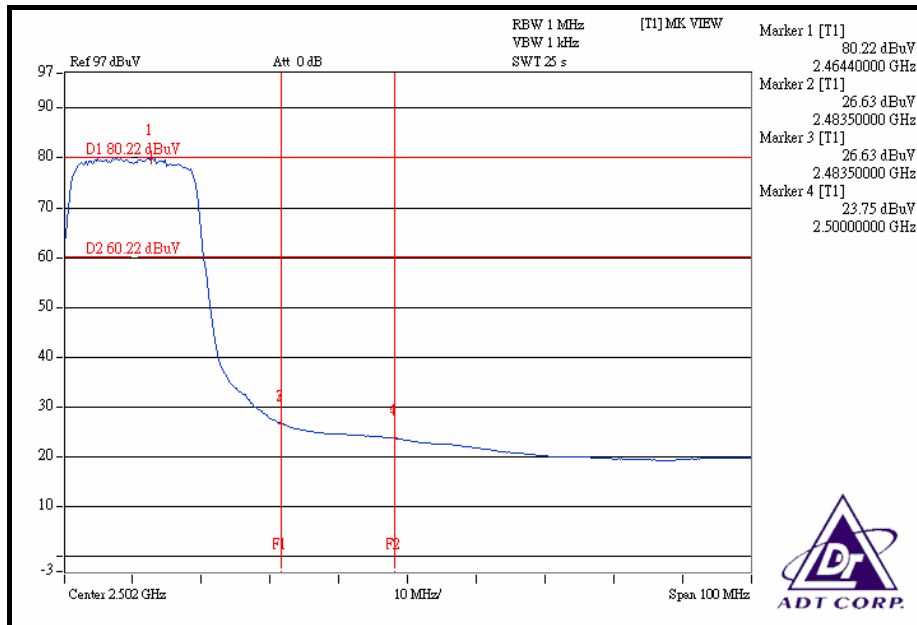

### **DRAFT 802.11n (40MHz) OFDM MODULATION:**

#### **NOTE 1:**

The band edge emission plot of OFDM technique on the next page shows 42.24dBc between carrier maximum power and local maximum emission in restrict band (2.38840GHz). The emission of carrier strength list in the test result of channel 1 at the item 4.2.7 is 105.48dBuV/m (Peak), so the maximum field strength in restrict band is  $105.48 - 42.24 = 63.24$  dBuV/m which is under 74dBuV/m limit.

The band edge emission plot of OFDM technique on the next page shows 45.19dBc between carrier maximum power and local maximum emission in restrict band (2.39000GHz). The emission of carrier strength list in the test result of channel 1 at the item 4.2.7 is 95.87dBuV/m (Average), so the maximum field strength in restrict band is  $95.87 - 45.19 = 50.68$  dBuV/m which is under 54dBuV/m limit.

#### **NOTE 2:**

The band edge emission plot of OFDM technique on the next second page shows 43.74dBc between carrier maximum power and local maximum emission in restrict band (2.48400GHz). The emission of carrier strength list in the test result of channel 7 at the item 4.2.7 is 106.45dBuV/m (Peak), so the maximum field strength in restrict band is  $106.45 - 43.74 = 62.71$  dBuV/m which is under 74dBuV/m limit.

The band edge emission plot of OFDM technique on the next third page shows 47.46dBc between carrier maximum power and local maximum emission in restrict band (2.48350GHz). The emission of carrier strength list in the test result of channel 7 at the item 4.2.7 is 96.75dBuV/m (Average), so the maximum field strength in restrict band is  $96.75 - 47.46 = 49.29$  dBuV/m which is under 54dBuV/m limit.

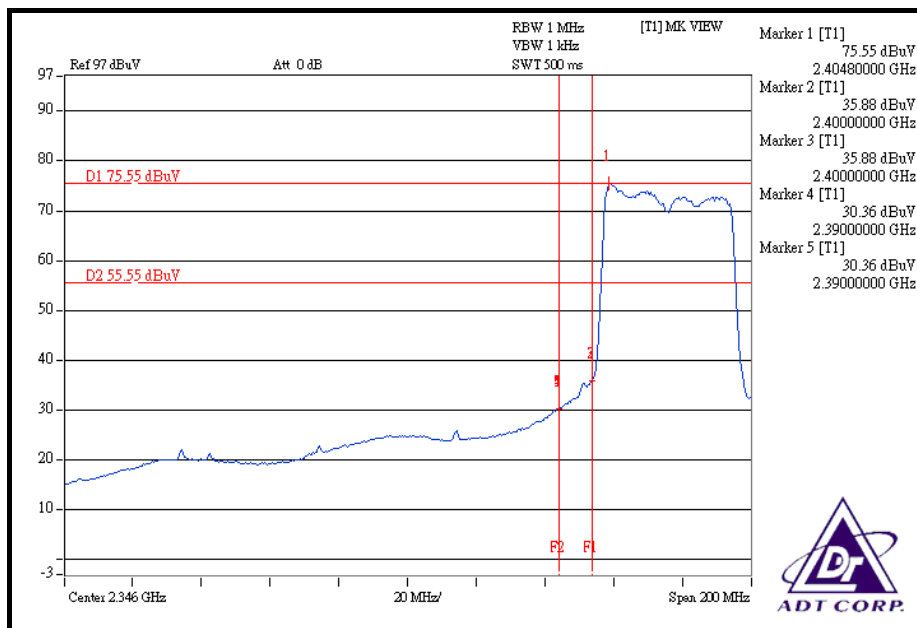
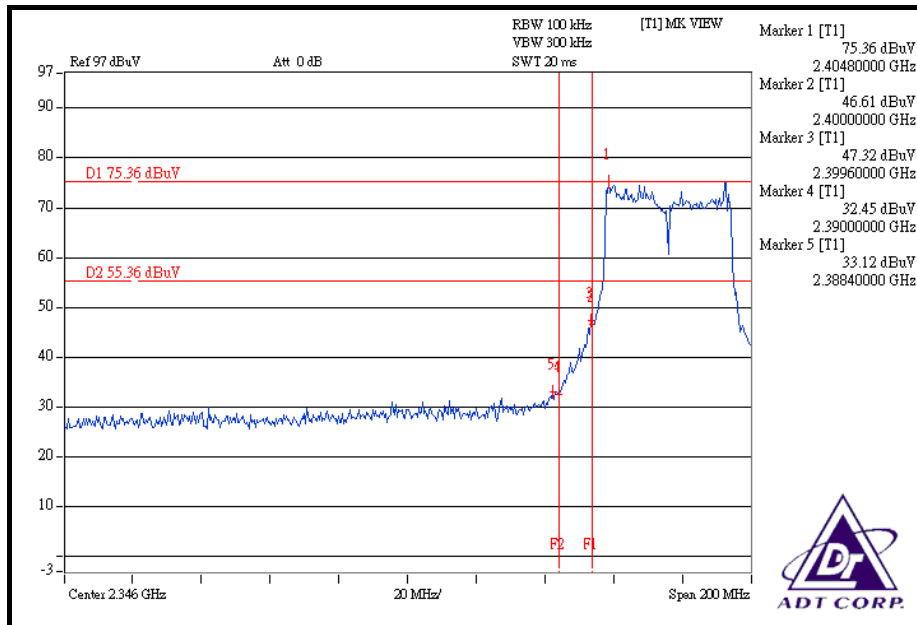

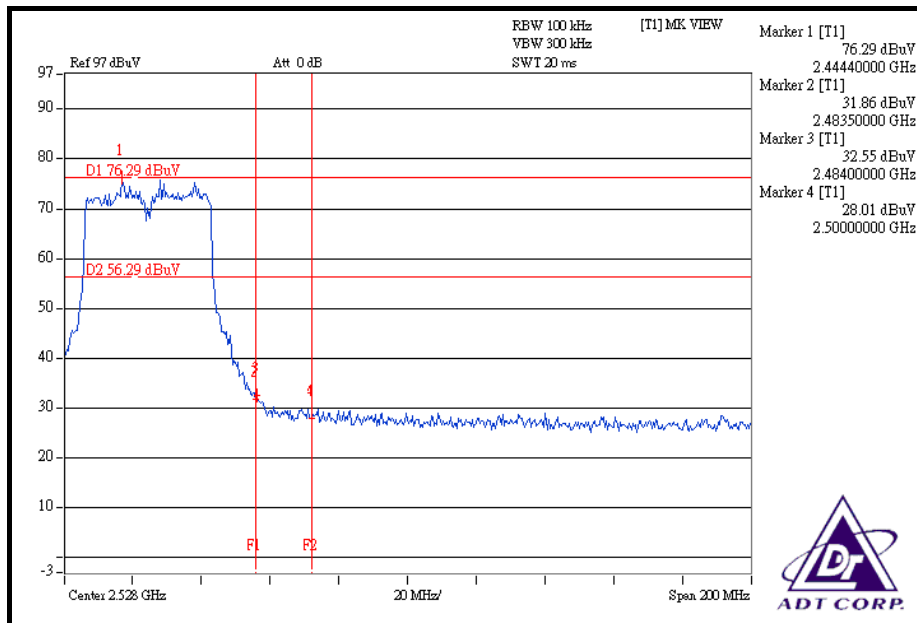
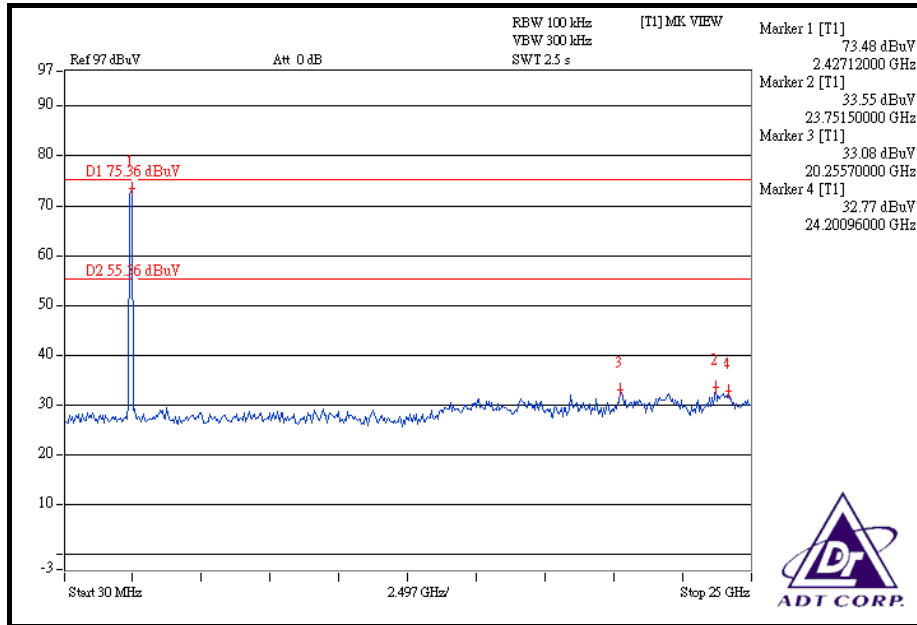

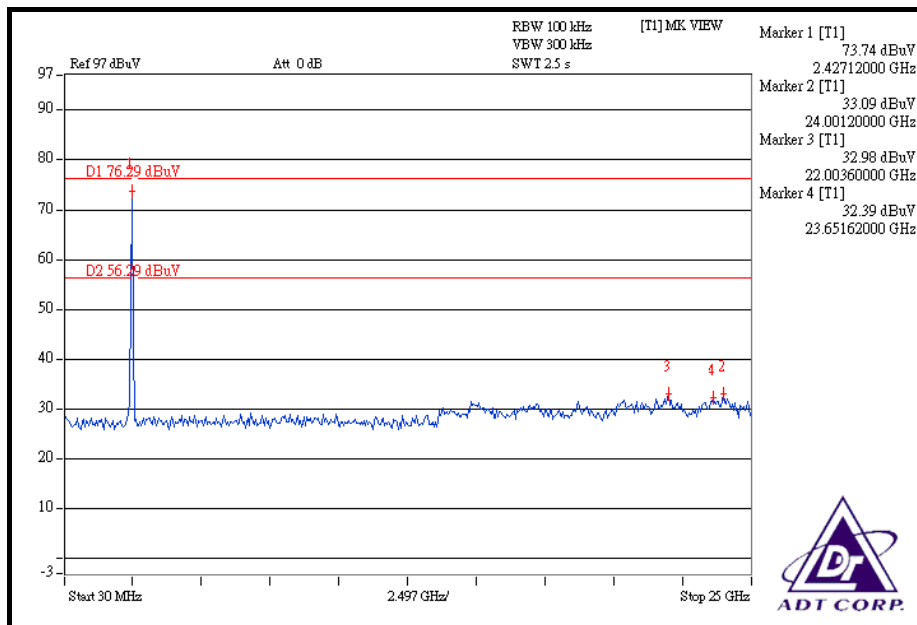
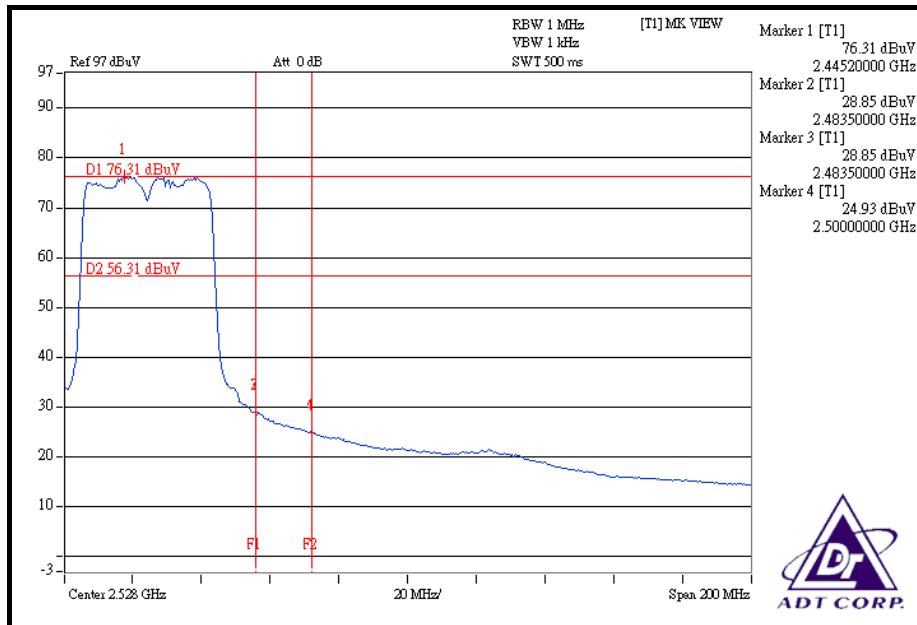



## **4.7 ANTENNA REQUIREMENT**

### **4.7.1 STANDARD APPLICABLE**

For intentional device, according to FCC 47 CFR Section 15.203, an intentional radiator shall be designed to ensure that no antenna other than that furnished by the responsible party shall be used with the device. And according to FCC 47 CFR Section 15.247 (b), if transmitting antennas of directional gain greater than 6dBi are used, the power shall be reduced by the amount in dB that the directional gain of the antenna exceeds 6dBi.

### **4.7.2 ANTENNA CONNECTED CONSTRUCTION**

The antenna used in this product is Dipole antenna with R-SMA connector. The maximum Gain of the antenna is 3dBi.





## 5. PHOTOGRAPHS OF THE TEST CONFIGURATION

Please refer to the attached file (Test Setup Photo).



## 6. INFORMATION ON THE TESTING LABORATORIES

We, ADT Corp., were founded in 1988 to provide our best service in EMC, Radio, Telecom and Safety consultation. Our laboratories are accredited and approved by the following approval agencies according to ISO/IEC 17025.

<b>USA</b>	FCC, UL, A2LA
<b>Germany</b>	TUV Rheinland
<b>Japan</b>	VCCI
<b>Norway</b>	NEMKO
<b>Canada</b>	INDUSTRY CANADA, CSA
<b>R.O.C.</b>	TAF, BSMI, NCC
<b>Netherlands</b>	Telefication
<b>Singapore</b>	GOST-ASIA(MOU)
<b>Russia</b>	CERTIS(MOU)

Copies of accreditation certificates of our laboratories obtained from approval agencies can be downloaded from our web site:

[www.adt.com.tw/index.5/phtml](http://www.adt.com.tw/index.5/phtml). If you have any comments, please feel free to contact us at the following:

**Linko EMC/RF Lab:**

Tel: 886-2-26052180

Fax: 886-2-26051924

**Hsin Chu EMC/RF Lab:**

Tel: 886-3-5935343

Fax: 886-3-5935342

**Hwa Ya EMC/RF/Safety Telecom Lab: Web Site: [www.adt.com.tw](http://www.adt.com.tw)**

Tel: 886-3-3183232

Fax: 886-3-3185050

The address and road map of all our labs can be found in our web site also.

## **7. APPENDIX A - MODIFICATIONS RECORDERS FOR ENGINEERING CHANGES TO THE EUT BY THE LAB**

No any modifications are made to the EUT by the lab during the test.