



FCC 47 CFR PART 15 SUBPART C

TEST REPORT

For

Bluetooth Audio Transmitter

Model: BT-WTM01

Trade Name: PCi

Issued to

**PLANEX COMMUNICATIONS INC.
F Nissei Ebisu Bldg 2F.16-3 Higashi 3-chome,
Shibuya-ku, Tokyo 150-0011, Japan**

Issued by

**Compliance Certification Services Inc.
No. 11, Wu-Gong 6th Rd., Wugu Industrial Park,
Taipei Hsien 248, Taiwan (R.O.C.)
<http://www.ccsrf.com>
service@ccsrf.com**





TABLE OF CONTENTS

1. TEST RESULT CERTIFICATION.....	3
2. EUT DESCRIPTION	4
3. TEST METHODOLOGY	5
3.1 EUT CONFIGURATION	5
3.2 EUT EXERCISE.....	5
3.3 GENERAL TEST PROCEDURES.....	5
3.4 FCC PART 15.205 RESTRICTED BANDS OF OPERATIONS	6
3.5 DESCRIPTION OF TEST MODES	7
4. INSTRUMENT CALIBRATION.....	8
4.1 MEASURING INSTRUMENT CALIBRATION	8
4.2 MEASUREMENT EQUIPMENT USED	8
4.3 MEASUREMENT UNCERTAINTY	9
5. FACILITIES AND ACCREDITATIONS	10
5.1 FACILITIES	10
5.2 EQUIPMENT.....	10
5.3 TABLE OF ACCREDITATIONS AND LISTINGS.....	11
6. SETUP OF EQUIPMENT UNDER TEST	12
6.1 SETUP CONFIGURATION OF EUT.....	12
6.2 SUPPORT EQUIPMENT	12
7. FCC PART 15.247 REQUIREMENTS.....	13
7.1 20 DB BANDWIDTH.....	13
7.2 PEAK POWER.....	18
7.3 AVERAGE POWER	20
7.4 BAND EDGES MEASUREMENT	21
7.5 PEAK POWER SPECTRAL DENSITY	30
7.6 FREQUENCY SEPARATION	36
7.7 NUMBER OF HOPPING FREQUENCY.....	39
7.8 TIME OF OCCUPANCY (DWELL TIME)	42
7.9 SPURIOUS EMISSIONS	55
7.10 POWERLINE CONDUCTED EMISSIONS.....	71
APPENDIX I RADIO FREQUENCY EXPOSURE.....	74
APPENDIX II PHOTOGRAPHS OF TEST SETUP.....	75
APPENDIX 1 - PHOTOGRAPHS OF EUT	



1. TEST RESULT CERTIFICATION

Applicant: PLANEX COMMUNICATIONS INC.
 F Nissei Ebisu Bldg 2F.16-3 Higashi 3-chome,
 Shibuya-ku,Tokyo 150-0011,Japan

Equipment Under Test: Bluetooth Audio Transmitter

Trade Name: PCi

Model: BT-WTM01

Date of Test: September 8 ~ November 15, 2010

APPLICABLE STANDARDS	
STANDARD	TEST RESULT
FCC 47 CFR Part 15 Subpart C	No non-compliance noted

We hereby certify that:

The above equipment was tested by Compliance Certification Services Inc. The test data, data evaluation, test procedures, and equipment configurations shown in this report were made in accordance with the procedures given in **ANSI C63.4: 2003** and the energy emitted by the sample EUT tested as described in this report is in compliance with the requirements of FCC Rules Part 15.207, 15.209, 15.247.

The test results of this report relate only to the tested sample EUT identified in this report.

Approved by:

Reviewed by:

Rex Lai
 Section Manager
 Compliance Certification Services Inc.

Gina Lo
 Section Manager
 Compliance Certification Services Inc.



2. EUT DESCRIPTION

Product	Bluetooth Audio Transmitter
Trade Name	PCi
Model Number	BT-WTM01
Model Discrepancy	N/A
Power Supply	Li-polymer Battery DC 3.7V
Frequency Range	2402 ~ 2480 MHz
Transmit Power	0.68 dBm
Modulation Technique	GFSK for 1Mbps; $\pi/4$ -DQPSK for 2Mbps; 8DPSK for 3Mbps
Transmit Data Rate	1, 2, 3Mbps
Number of Channels	79 Channels
Antenna Specification	Gain: -2.9 dBi
Antenna Designation	Printing Antenna

Remark:

1. The sample selected for test was production product and was provided by manufacturer.
2. This submittal(s) (test report) is intended for FCC ID: **SJ9-BT-WTM01** filing to comply with Section 15.207, 15.209 and 15.247 of the FCC Part 15, Subpart C Rules.



3. TEST METHODOLOGY

The tests documented in this report were performed in accordance with ANSI C63.4 and FCC CFR 47 Part 15.207, 15.209 and 15.247.

3.1 EUT CONFIGURATION

The EUT configuration for testing is installed on RF field strength measurement to meet the Commissions requirement and operating in a manner that intends to maximize its emission characteristics in a continuous normal application.

3.2 EUT EXERCISE

The EUT was operated in the engineering mode to fix the TX frequency that was for the purpose of the measurements.

According to its specifications, the EUT must comply with the requirements of the Section 15.207, 15.209 and 15.247 under the FCC Rules Part 15 Subpart C.

3.3 GENERAL TEST PROCEDURES

Conducted Emissions

The EUT is placed on the turntable, which is 0.8 m above ground plane. According to the requirements in Section 13.1.4.1 of ANSI C63.4 Conducted emissions from the EUT measured in the frequency range between 0.15 MHz and 30MHz using CISPR Quasi-peak and average detector modes.

Radiated Emissions

The EUT is placed on a turn table, which is 0.8 m above ground plane. The turntable shall rotate 360 degrees to determine the position of maximum emission level. EUT is set 3m away from the receiving antenna, which varied from 1m to 4m to find out the highest emission. And also, each emission was to be maximized by changing the polarization of receiving antenna both horizontal and vertical. In order to find out the maximum emissions, exploratory radiated emission measurements were made according to the requirements in Section 13.1.4.1 of ANSI C63.4.



3.4 FCC PART 15.205 RESTRICTED BANDS OF OPERATIONS

(a) Except as shown in paragraph (d) of this section, only spurious emissions are permitted in any of the frequency bands listed below:

MHz	MHz	MHz	GHz
0.090 - 0.110	16.42 - 16.423	399.9 - 410	4.5 - 5.15
¹ 0.495 - 0.505	16.69475 - 16.69525	608 - 614	5.35 - 5.46
2.1735 - 2.1905	16.80425 - 16.80475	960 - 1240	7.25 - 7.75
4.125 - 4.128	25.5 - 25.67	1300 - 1427	8.025 - 8.5
4.17725 - 4.17775	37.5 - 38.25	1435 - 1626.5	9.0 - 9.2
4.20725 - 4.20775	73 - 74.6	1645.5 - 1646.5	9.3 - 9.5
6.215 - 6.218	74.8 - 75.2	1660 - 1710	10.6 - 12.7
6.26775 - 6.26825	108 - 121.94	1718.8 - 1722.2	13.25 - 13.4
6.31175 - 6.31225	123 - 138	2200 - 2300	14.47 - 14.5
8.291 - 8.294	149.9 - 150.05	2310 - 2390	15.35 - 16.2
8.362 - 8.366	156.52475 -	2483.5 - 2500	17.7 - 21.4
8.37625 - 8.38675	156.52525	2655 - 2900	22.01 - 23.12
8.41425 - 8.41475	156.7 - 156.9	3260 - 3267	23.6 - 24.0
12.29 - 12.293	162.0125 - 167.17	3332 - 3339	31.2 - 31.8
12.51975 - 12.52025	167.72 - 173.2	3345.8 - 3358	36.43 - 36.5
12.57675 - 12.57725	240 - 285	3600 - 4400	(²)
13.36 - 13.41	322 - 335.4		

¹ Until February 1, 1999, this restricted band shall be 0.490-0.510 MHz.

² Above 38.6

(b) Except as provided in paragraphs (d) and (e), the field strength of emissions appearing within these frequency bands shall not exceed the limits shown in Section 15.209. At frequencies equal to or less than 1000 MHz, compliance with the limits in Section 15.209 shall be demonstrated using measurement instrumentation employing a CISPR quasi-peak detector. Above 1000 MHz, compliance with the emission limits in Section 15.209 shall be demonstrated based on the average value of the measured emissions. The provisions in Section 15.35 apply to these measurements.



3.5 DESCRIPTION OF TEST MODES

The EUT (model: BT-WTM01) had been tested under operating condition.

Test program used to control the EUT for staying in continuous transmitting mode was programmed.

Software used to control the EUT for staying in continuous transmitting mode was programmed.

The worst case data rate is determined as the data rate with highest output power.

After verification, all tests were carried out with the worst case test modes as shown below except radiated spurious emission below 1GHz and power line conducted emissions below 30MHz, which worst case was in normal link mode only.

During the preliminary test, GFSK, $\pi/4$ -QPSK & 8DPSK with DH1 were pre-tested and found that 8DPSK emits the highest output power. Then the tests were carried on with DH1 compare to DH3 & DH5 and found that 8DPSK with DH5 emit the highest output power, and therefore had been tested under operating condition.

Following channels were selected for the radiated emission testing only as listed below:

Tested Channel	Modulation Type	Packet Type	Data Rate
Low, Mid, High	GFSK	DH 5	1
Low, Mid, High	8DPSK	DH 5	3



4. INSTRUMENT CALIBRATION

4.1 MEASURING INSTRUMENT CALIBRATION

The measuring equipment, which was utilized in performing the tests documented herein, has been calibrated in accordance with the manufacturer's recommendations for utilizing calibration equipment, which is traceable to recognized national standards.

4.2 MEASUREMENT EQUIPMENT USED

Equipment Used for Emissions Measurement

Remark: Each piece of equipment is scheduled for calibration once a year and Loop Antenna is scheduled for calibration once three years.

Conducted Emissions Test Site				
Name of Equipment	Manufacturer	Model	Serial Number	Calibration Due
Spectrum Analyzer	Agilent	E4446A	MY43360131	03/03/2011
Power Meter	Agilent	E4416A	GB41291611	06/27/2011
Power Sensor	Agilent	E9327A	US40441097	06/27/2011

3M Semi Anechoic Chamber				
Name of Equipment	Manufacturer	Model	Serial Number	Calibration Due
Spectrum Analyzer	Agilent	E4446A	US42510252	10/26/2011
EMI Test Receiver	R&S	ESCI	100064	02/04/2011
Pre-Amplifier	Mini-Circuits	ZFL-1000LN	SF350700823	01/12/2011
Pre-Amplifier	MITEQ	AFS44-00102650-42-10P-44	1415367	11/20/2010
Bilog Antenna	Sunol Sciences	JB3	A030105	09/10/2011
Horn Antenna	EMCO	3117	00055165	12/07/2010
Loop Antenna	EMCO	6502	8905/2356	06/10/2013
Turn Table	CCS	CC-T-1F	N/A	N.C.R
Antenna Tower	CCS	CC-A-1F	N/A	N.C.R
Controller	CCS	CC-C-1F	N/A	N.C.R
Site NSA	CCS	N/A	N/A	12/31/2010
Test S/W	EZ-EMC (CCS-3A1RE)			

Powerline Conducted Emissions Test Site				
Name of Equipment	Manufacturer	Model	Serial Number	Calibration Due
EMI Test Receiver	R&S	ESHS10	843743/015	03/25/2011
LISN	SCHWARZBECK	NSLK 8127	8127-541	03/14/2011
LISN	SCHAFFNER	NNB 41	03/10013	12/03/2010
Test S/W	CCS-3A1-CE			



4.3 MEASUREMENT UNCERTAINTY

PARAMETER	UNCERTAINTY
Powerline Conducted Emission	+/- 1.6202
3M Semi Anechoic Chamber / 30M~200M	+/- 4.0606
3M Semi Anechoic Chamber / 200M~1000M	+/- 3.9979
3M Semi Anechoic Chamber / 1G~8G	+/- 2.5790
3M Semi Anechoic Chamber / 8G~18G	+/- 2.5928
3M Semi Anechoic Chamber / 18G~26G	+/- 2.7212
3M Semi Anechoic Chamber / 26G~40G	+/- 2.9520

Remark: This uncertainty represents an expanded uncertainty expressed at approximately the 95% confidence level using a coverage factor of $k=2$.



5. FACILITIES AND ACCREDITATIONS

5.1 FACILITIES

All measurement facilities used to collect the measurement data are located at

No.199, Chunghsen Road, Hsintien City, Taipei Hsien, Taiwan, R.O.C.

Tel: 886-2-2217-0894 / Fax: 886-2-2217-1029

No.11, Wugong 6th Rd., Wugu Industrial Park, Taipei Hsien 248, Taiwan

Tel: 886-2-2299-9720 / Fax: 886-2-2298-4045

No.81-1, Lane 210, Bade 2nd Rd., Luchu Hsiang, Taoyuan Hsien 338, Taiwan

Tel: 886-3-324-0332 / Fax: 886-3-324-5235

The sites are constructed in conformance with the requirements of ANSI C63.7, ANSI C63.4 and CISPR Publication 22.

5.2 EQUIPMENT

Radiated emissions are measured with one or more of the following types of linearly polarized antennas: tuned dipole, biconical, log periodic, bi-log, and/or ridged waveguide, horn. Spectrum analyzers with pre-selectors and quasi-peak detectors are used to perform radiated measurements.



Conducted emissions are measured with Line Impedance Stabilization Networks and EMI Test Receivers.

Calibrated wideband preamplifiers, coaxial cables, and coaxial attenuators are also used for making measurements.

All receiving equipment conforms to CISPR Publication 16-1, "Radio Interference Measuring Apparatus and Measurement Methods."



5.3 TABLE OF ACCREDITATIONS AND LISTINGS

Country	Agency	Scope of Accreditation	Logo
USA	FCC	3M Semi Anechoic Chamber (FCC MRA: TW1039) to perform FCC Part 15 measurements	 FCC MRA: TW1039
Taiwan	TAF	LP0002, RTTE01, FCC Method-47 CFR Part 15 Subpart C, D, E, RSS-210, RSS-310 IDA TS SRD, AS/NZS 4268, AS/NZS 4771, TS 12.1 & 12.2, ETSI EN 300 440-1, ETSI EN 300 440-2, ETSI EN 300 328, ETSI EN 300 220-1, ETSI EN 300 220-2, ETSI EN 301 893, ETSI EN 301 489-1/3/7/17 FCC OET Bulletin 65 + Supplement C, EN 50360, EN 50361, EN 50371, RSS 102, EN 50383, EN 50385, EN 50392, IEC 62209, CNS 14958-1, CNS 14959 FCC Method -47 CFR Part 15 Subpart B IEC / EN 61000-3-2, IEC / EN 61000-3-3, IEC / EN 61000-4-2/3/4/5/6/8/11	
Canada	Industry Canada	3M Semi Anechoic Chamber (IC 2324G-1 / IC 2324G-2) to perform	 IC 2324G-1 IC 2324G-2

** No part of this report may be used to claim or imply product endorsement by A2LA or any agency of the US Government.*



6. SETUP OF EQUIPMENT UNDER TEST

6.1 SETUP CONFIGURATION OF EUT

See test photographs attached in Appendix II for the actual connections between EUT and support equipment.

6.2 SUPPORT EQUIPMENT

No.	Device Type	Brand	Model	Series No.	FCC ID	Data Cable	Power Cord
1.	Notebook PC	DELL	PP10L	7B3ZP1S	FCC DoC	N/A	AC I/P: Unshielded, 1.8m DC O/P: Unshielded, 1.8m with a core
2.	Notebook PC	DELL	PP05L	CBNLD1S	E2K5HCKT	N/A	AC I/P: Unshielded, 1.8m DC O/P: Unshielded, 1.8m with a core
3.	LCD Monitor	DELL	2408WFPb	CN-OG293H-74261-95M-1KGS	FCC DoC	Shielded, 1.8m with 2 cores	Unshielded, 1.8m
4.	iPod	Apple	MA978TA/A	YM741QDHY0P	N/A	USB Cable, Unshielded, 1m	N/A
5.	320GB 2.5" HDD	Seagate	9ZA2MG-500	538224 2806	FCC DoC	Shielded, 1.8m	N/A
6.	USB Mouse	HP	M-UAL-96	570580-001	FCC DoC	Shielded, 1.8m	N/A
7.	Test Kit	N/A	N/A	N/A	N/A	N/A	N/A

Remark:

1. All the equipment/cables were placed in the worst-case configuration to maximize the emission during the test.
2. Grounding was established in accordance with the manufacturer's requirements and conditions for the intended use.



7. FCC PART 15.247 REQUIREMENTS

7.1 20 DB BANDWIDTH

LIMIT

None; for reporting purposes only.

Test Configuration

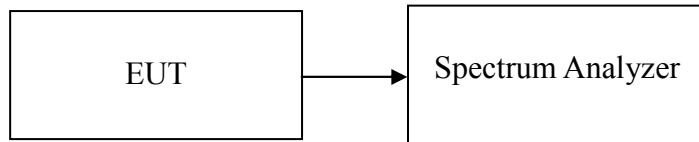

TEST PROCEDURE

1. Place the EUT on the table and set it in the transmitting mode.
2. Remove the antenna from the EUT and then connect a low loss RF cable from the antenna port to the spectrum analyzer.
3. Set the spectrum analyzer as for GFSK RBW=10 kHz, VBW = 30 kHz, Span = 1.5MHz, Sweep = auto. / for 8DPSK RBW=10 kHz, VBW = 30 kHz, Span = 3MHz, Sweep = auto.
4. Mark the peak frequency and 20dB (upper and lower) frequency.
5. Repeat until all the rest channels are investigated.

TEST RESULTS

No non-compliance noted.

Test Data

For GFSK / DH5

Channel	Frequency (MHz)	20dB Bandwidth (MHz)
Low	2402	0.866
Mid	2441	0.917
High	2480	0.918

For 8DPSK / DH5

Channel	Frequency (MHz)	20dB Bandwidth (MHz)
Low	2402	1260
Mid	2441	1265
High	2480	1285



Test Plot

For GFSK / DH5

20dB Bandwidth (CH Low)

Agilent 15:30:30 Oct 8, 2010

R T

Δ Mkr2 866 kHz
-1.24 dB

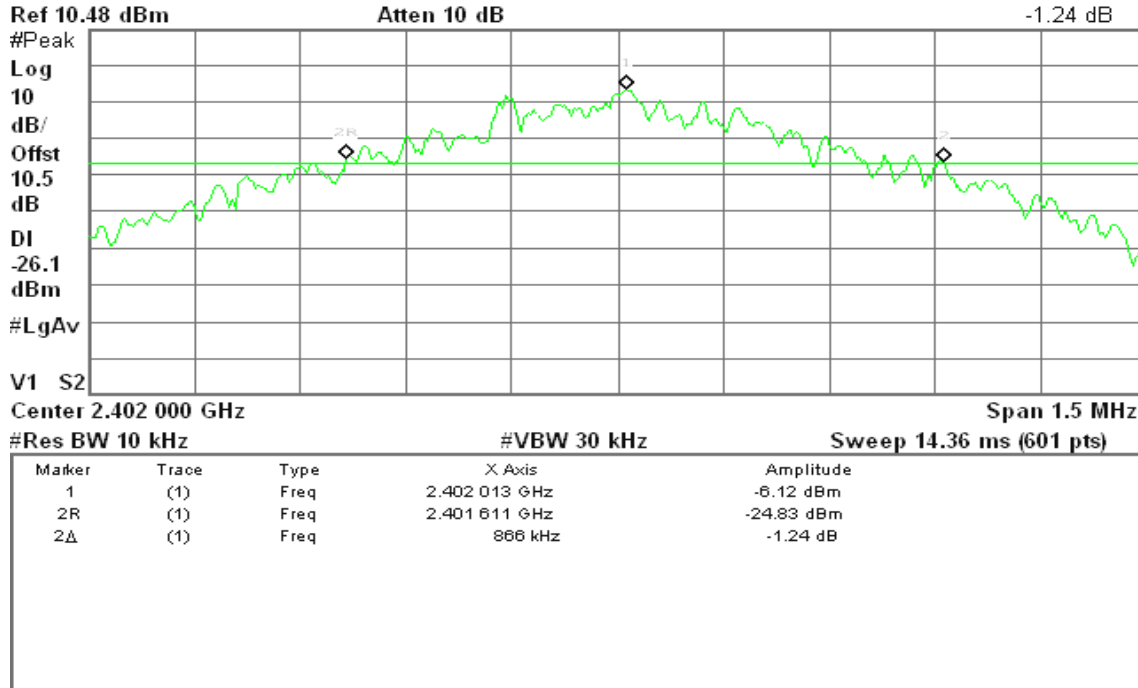

20dB Bandwidth (CH Mid)

Agilent 15:29:25 Oct 8, 2010

R T

Δ Mkr2 917 kHz
-0.06 dB

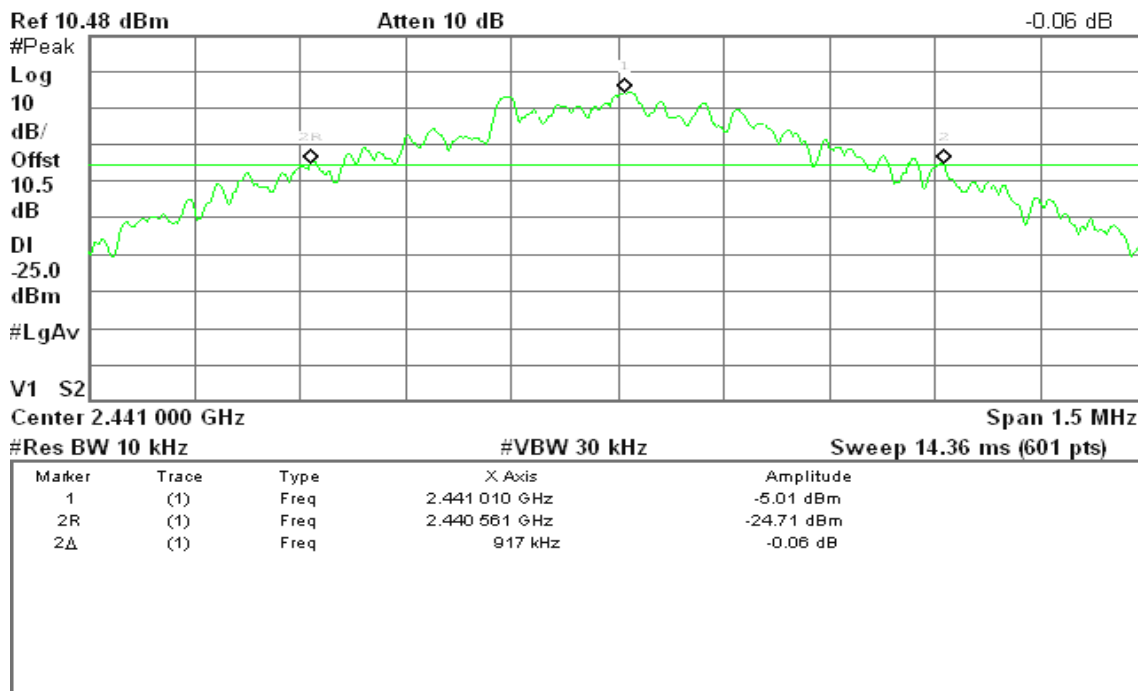



20dB Bandwidth (CH High)

Agilent 15:28:18 Oct 8, 2010

R T

Δ Mkr2 918 kHz
-0.27 dB

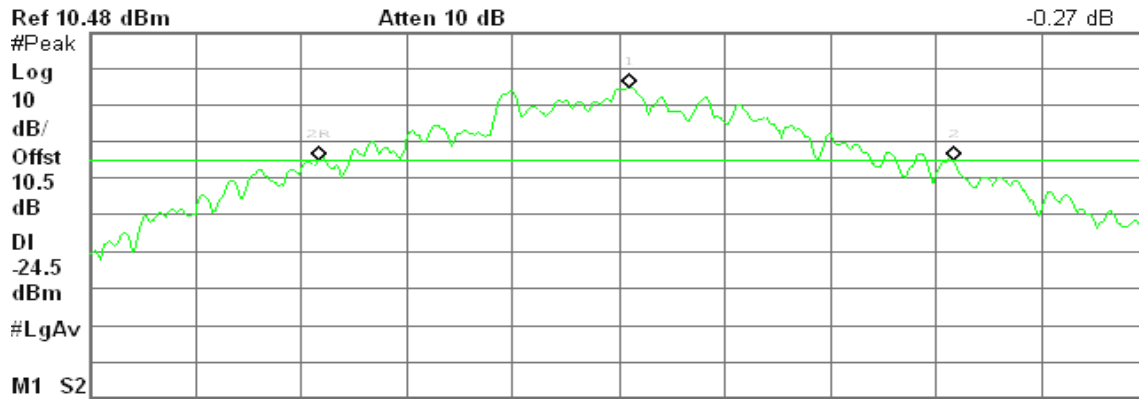

Center 2.480 000 GHz Span 1.5 MHz
 #Res BW 10 kHz #VBW 30 kHz Sweep 14.36 ms (601 pts)

Marker	Trace	Type	X Axis	Amplitude
1	(1)	Freq	2.480 015 GHz	-4.52 dBm
2R	(1)	Freq	2.479 561 GHz	-24.51 dBm
2Δ	(1)	Freq	918 kHz	-0.27 dB



For 8DPSK / DH5

20dB Bandwidth (CH Low)

Agilent 15:46:44 Oct 8, 2010

R T

Δ Mkr2 1.260 MHz

0.17 dB

Ref 10.48 dBm

Atten 10 dB

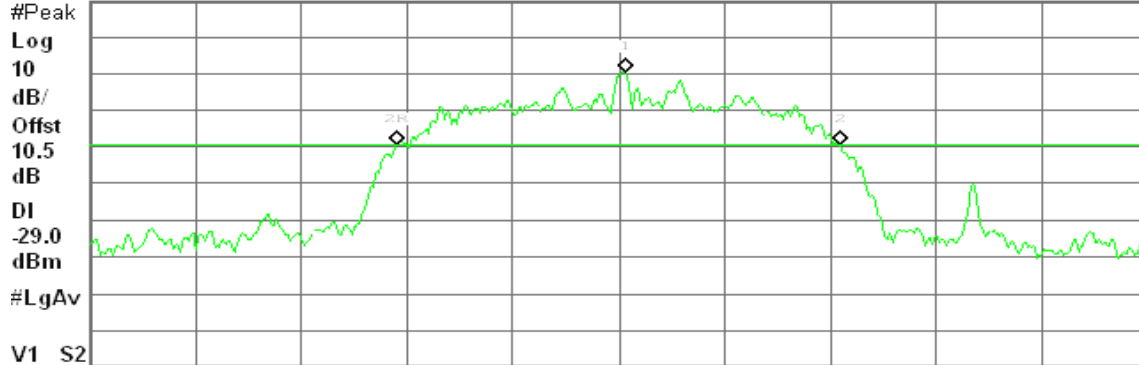

Center 2.402 000 GHz

Span 3 MHz

#Res BW 10 kHz

#VBW 30 kHz

Sweep 28.68 ms (601 pts)

Marker	Trace	Type	X Axis	Amplitude
1	(1)	Freq	2.402 020 GHz	-9.05 dBm
2R	(1)	Freq	2.401 370 GHz	-29.04 dBm
2Δ	(1)	Freq	1.260 MHz	0.17 dB

20dB Bandwidth (CH Mid)

Agilent 15:47:29 Oct 8, 2010

R T

Δ Mkr2 1.265 MHz

-1.17 dB

Ref 10.48 dBm

Atten 10 dB

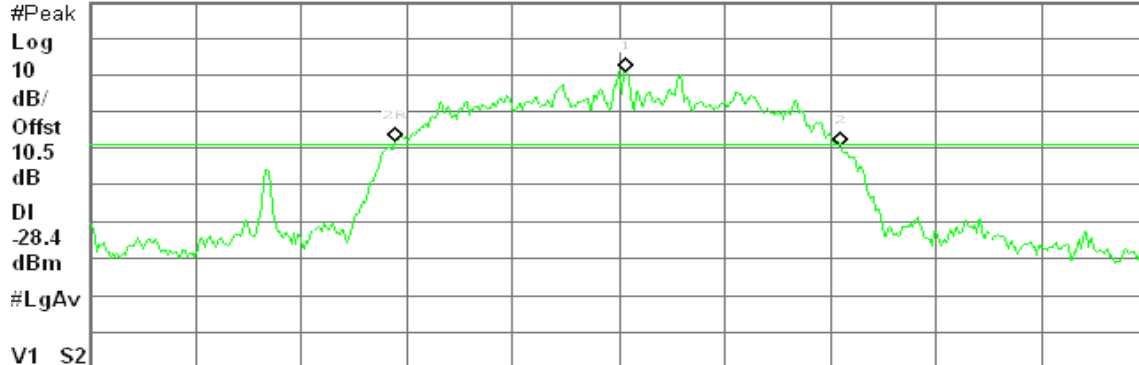

Center 2.441 000 GHz

Span 3 MHz

#Res BW 10 kHz

#VBW 30 kHz

Sweep 28.68 ms (601 pts)

Marker	Trace	Type	X Axis	Amplitude
1	(1)	Freq	2.441 020 GHz	-8.38 dBm
2R	(1)	Freq	2.440 365 GHz	-27.83 dBm
2Δ	(1)	Freq	1.265 MHz	-1.17 dB



20dB Bandwidth (CH High)

Agilent 15:48:23 Oct 8, 2010

R T

Δ Mkr2 1.285 MHz
1.07 dB

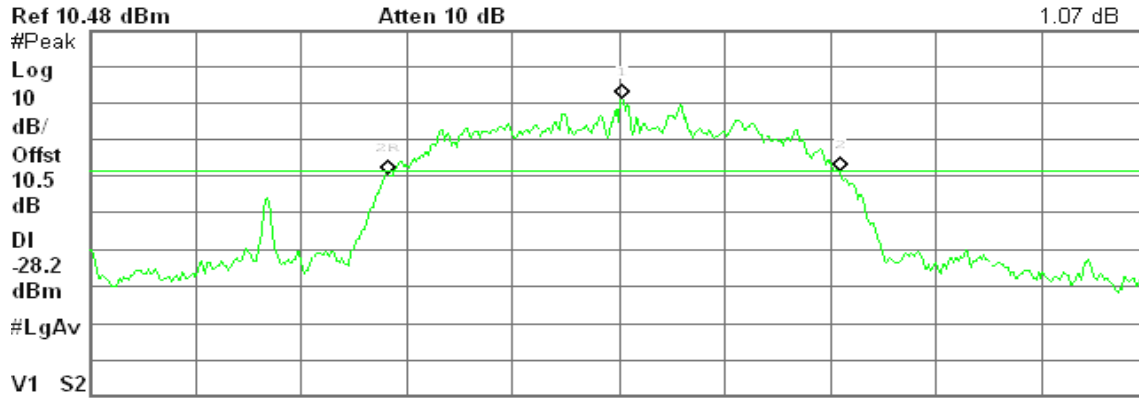

Marker	Trace	Type	X Axis	Amplitude
1	(1)	Freq	2.480 010 GHz	-8.19 dBm
2R	(1)	Freq	2.479 345 GHz	-28.92 dBm
2Δ	(1)	Freq	1.285 MHz	1.07 dB



7.2 PEAK POWER

LIMIT

The maximum peak output power of the intentional radiator shall not exceed the following:

1. According to §15.247(a)(1), Frequency hopping systems shall have hopping channel carrier frequencies separated by a minimum of 25 kHz or the 20 dB bandwidth of the hopping channel, whichever is greater. Alternatively, frequency hopping systems operating in the 2400-2483.5 MHz band may have hopping channel carrier frequencies that are separated by 25 kHz or two-thirds of the 20 dB bandwidth of the hopping channel, whichever is greater, provided the systems operate with an output power no greater than 125 mW.
2. According to §15.247(b)(3), for systems using digital modulation in the bands of 902-928 MHz, 2400-2483.5 MHz, and 5725-5850 MHz: 1 Watt.
3. According to §15.247(b)(4), the conducted output power limit specified in paragraph (b) of this section is based on the use of antennas with directional gains that do not exceed 6 dBi. Except as shown in paragraph (c) of this section, if transmitting antennas of directional gain greater than 6 dBi are used, the conducted output power from the intentional radiator shall be reduced below the stated values in paragraphs (b)(1), (b)(2), and (b)(3) of this section, as appropriate, by the amount in dB that the directional gain of the antenna exceeds 6 dBi.

Test Configuration

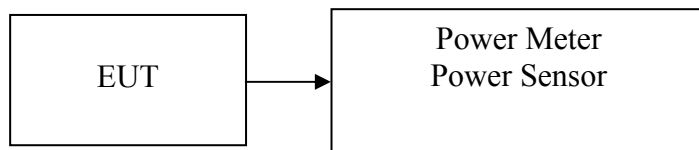

TEST PROCEDURE

The transmitter output is connected to the Power Meter. The Power Meter is set to the peak power detection.

TEST RESULTS

No non-compliance noted.



Test Data

For GFSK / DH5

Channel	Frequency (MHz)	Output Power (dBm)	Output Power (W)	Limit (W)	Result
Low	2402	-0.67	0.0009	0.125	PASS
Mid	2441	0.43	0.0011		PASS
High	2480	0.68	0.0012		PASS

For 8DPSK / DH5

Channel	Frequency (MHz)	Output Power (dBm)	Output Power (W)	Limit (W)	Result
Low	2402	-2.24	0.0006	0.125	PASS
Mid	2441	-0.71	0.0008		PASS
High	2480	-0.88	0.0008		PASS



7.3 AVERAGE POWER

LIMIT

None; for reporting purposes only.

Test Configuration

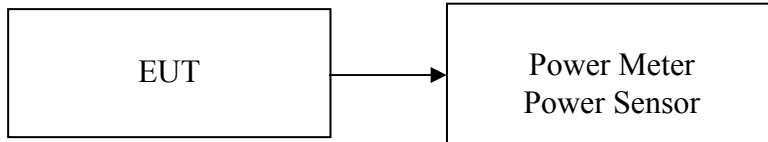

TEST PROCEDURE

The transmitter output is connected to the Power Meter. The Power Meter is set to the peak power detection.

TEST RESULTS

No non-compliance noted.

Test Data

For GFSK / DH5

Channel	Frequency (MHz)	Output Power (dBm)	Output Power (W)
Low	2402	-2.33	0.0006
Mid	2441	-0.80	0.0008
High	2480	-0.55	0.0009

For 8DPSK / DH5

Channel	Frequency (MHz)	Output Power (dBm)	Output Power (W)
Low	2402	-6.48	0.0002
Mid	2441	-4.50	0.0004
High	2480	-4.97	0.0003



7.4 BAND EDGES MEASUREMENT

LIMIT

According to §15.247(d), in any 100 kHz bandwidth outside the frequency bands in which the spread spectrum intentional radiator is operating, the radio frequency power that is produced by the intentional radiator shall be at least 20 dB below that in the 100 kHz bandwidth within the band that contains the highest level of the desired power, based on either an RF conducted or a radiated measurement, provided the transmitter demonstrates compliance with the peak conducted power limits. In addition, radiated emissions which fall in the restricted bands, as defined in §15.205(a), must also comply with the radiated emission limits specified in 15.209(a) (see Section 15.205(c)).

Test Configuration

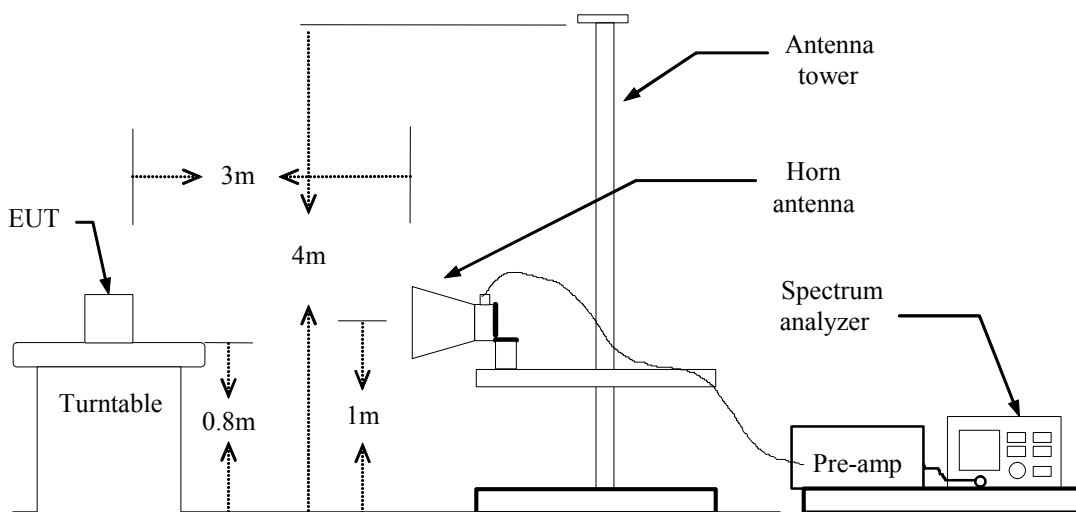

TEST PROCEDURE

1. The EUT is placed on a turntable, which is 0.8m above the ground plane.
2. The turntable shall be rotated for 360 degrees to determine the position of maximum emission level.
3. EUT is set 3m away from the receiving antenna, which is varied from 1m to 4m to find out the highest emission.
4. Set the spectrum analyzer in the following setting in order to capture the lower and upper band-edges of the emission:
 - (a) PEAK: RBW=VBW=1MHz / Sweep=AUTO
 - (b) AVERAGE: RBW=1MHz / VBW=10Hz / Sweep=AUTO
5. Repeat the procedures until all the PEAK and AVERAGE versus POLARIZATION are measured.

TEST RESULTS

Refer to attach spectrum analyzer data chart.



For GFSK / DH5

Band Edges (CH Low)

Detector mode: Peak

Polarity: Vertical

Agilent 15:50:33 Oct 7, 2010

R T

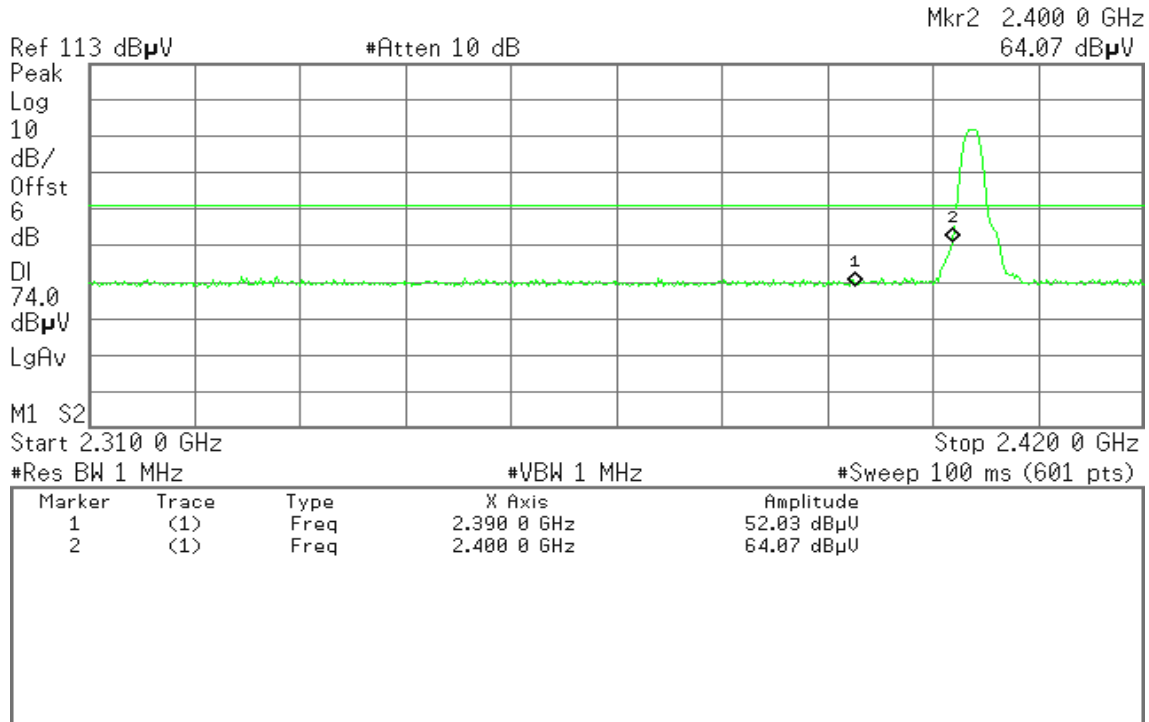

Detector mode: Average

Polarity: Vertical

Agilent 15:49:46 Oct 7, 2010

R T

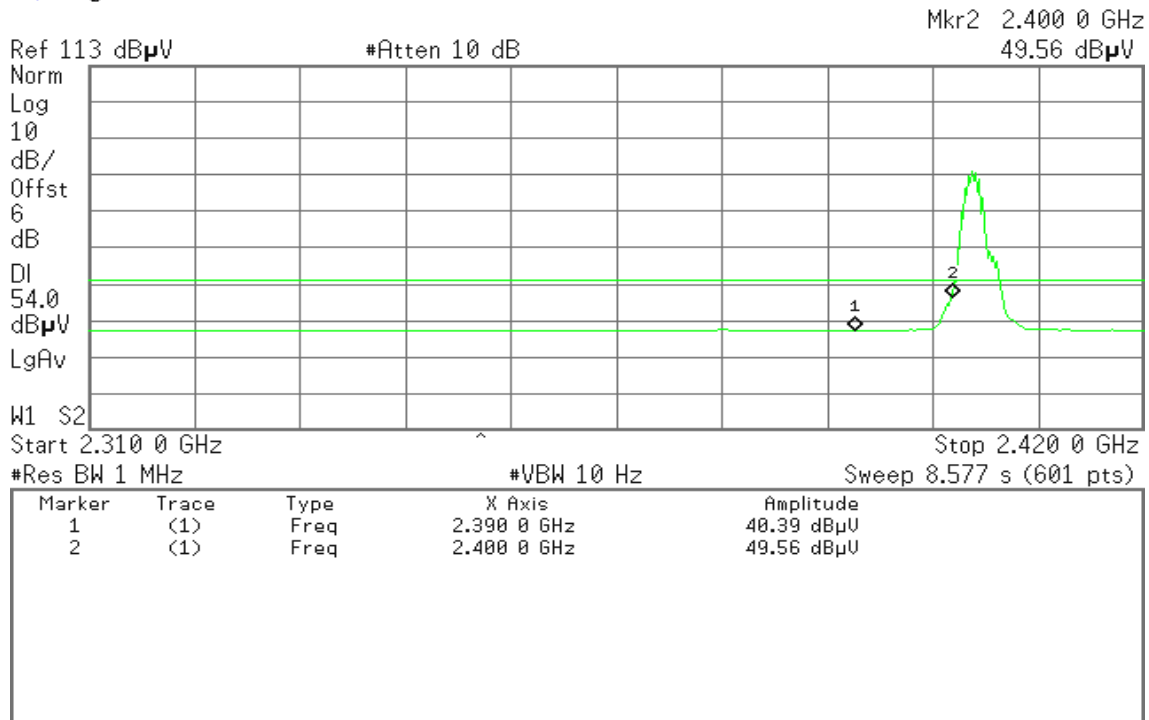



Detector mode: Peak

Polarity: Horizontal

Agilent 15:42:01 Oct 7, 2010

R T

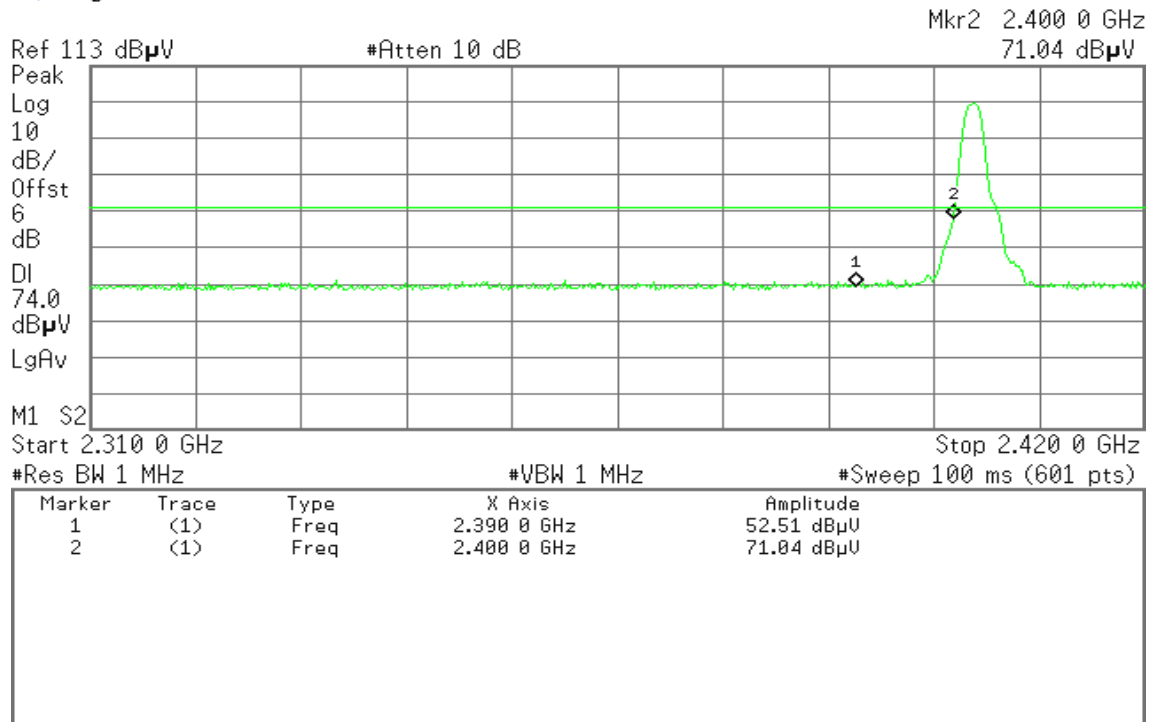

Detector mode: Average

Polarity: Horizontal

Agilent 15:41:31 Oct 7, 2010

R T

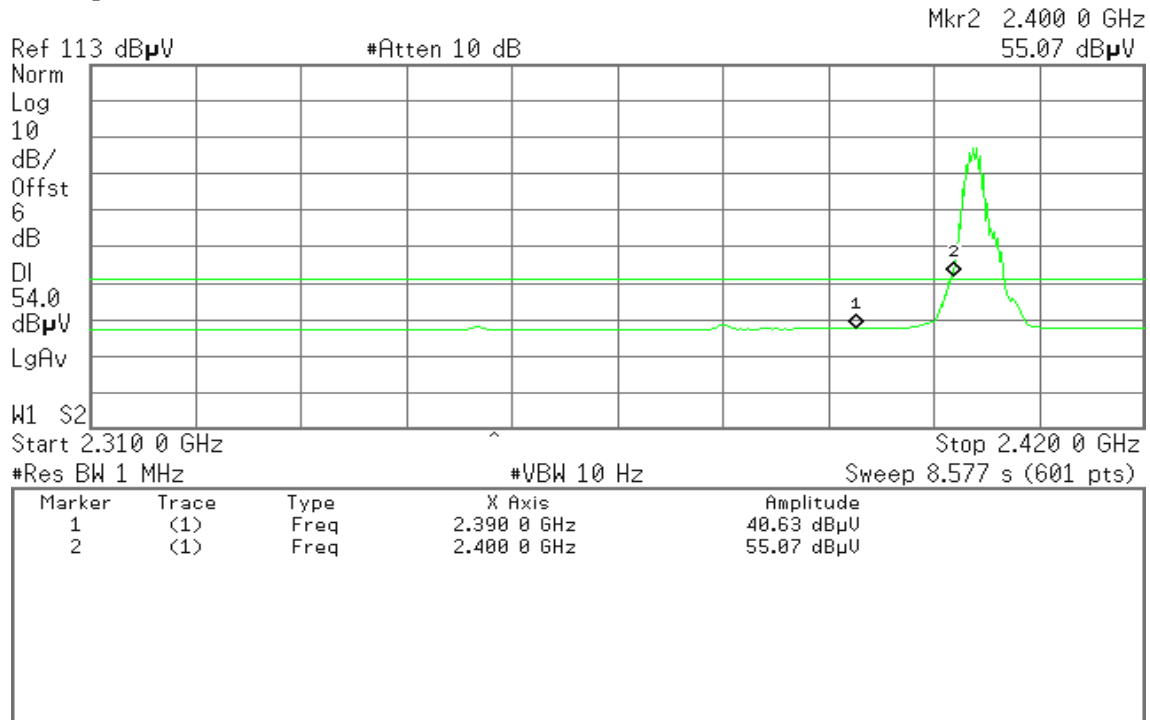



Band Edges (CH High)

Detector mode: Peak

Polarity: Vertical

Agilent 15:56:25 Oct 7, 2010

R T

Mkr1 2.483 50 GHz
53.45 dB μ V

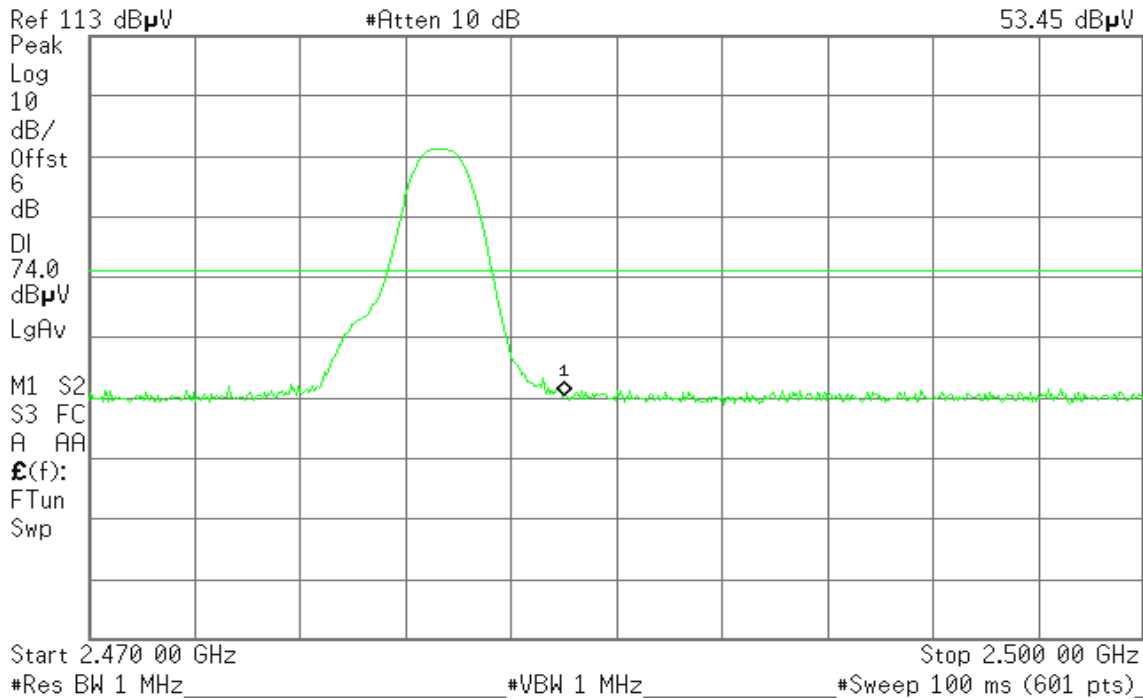

Detector mode: Average

Polarity: Vertical

Agilent 15:56:05 Oct 7, 2010

R T

Mkr1 2.483 50 GHz
41.01 dB μ V

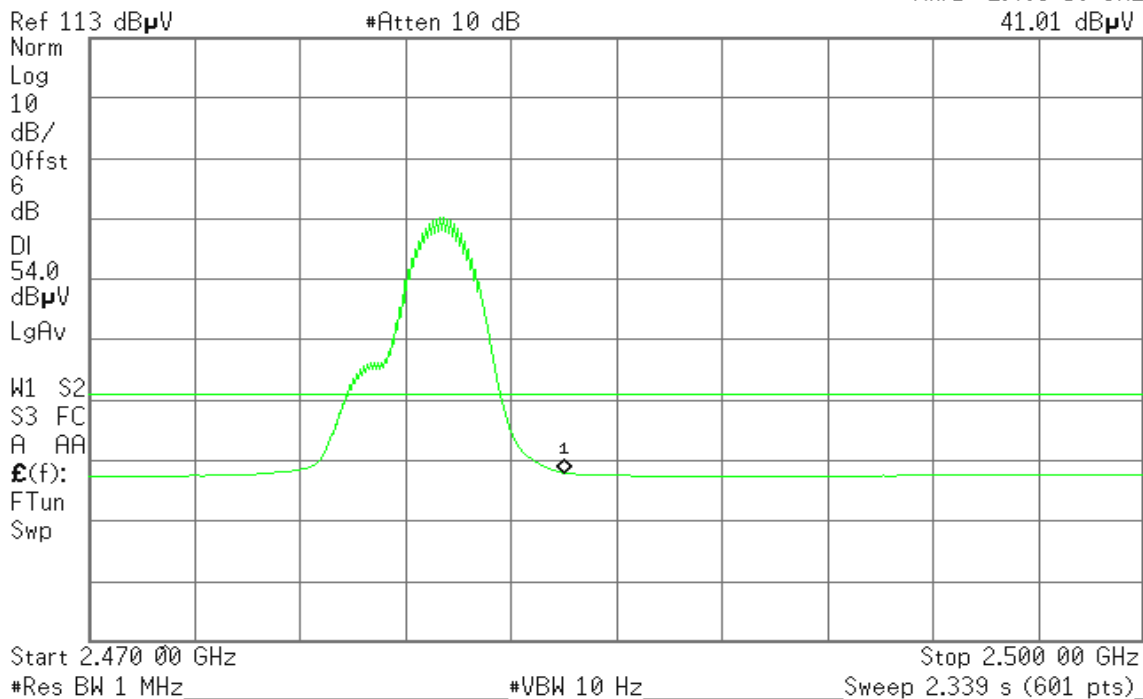



Detector mode: Peak

Polarity: Horizontal

Agilent 16:01:37 Oct 7, 2010

R T

Mkr1 2.483 50 GHz
55.11 dB μ V

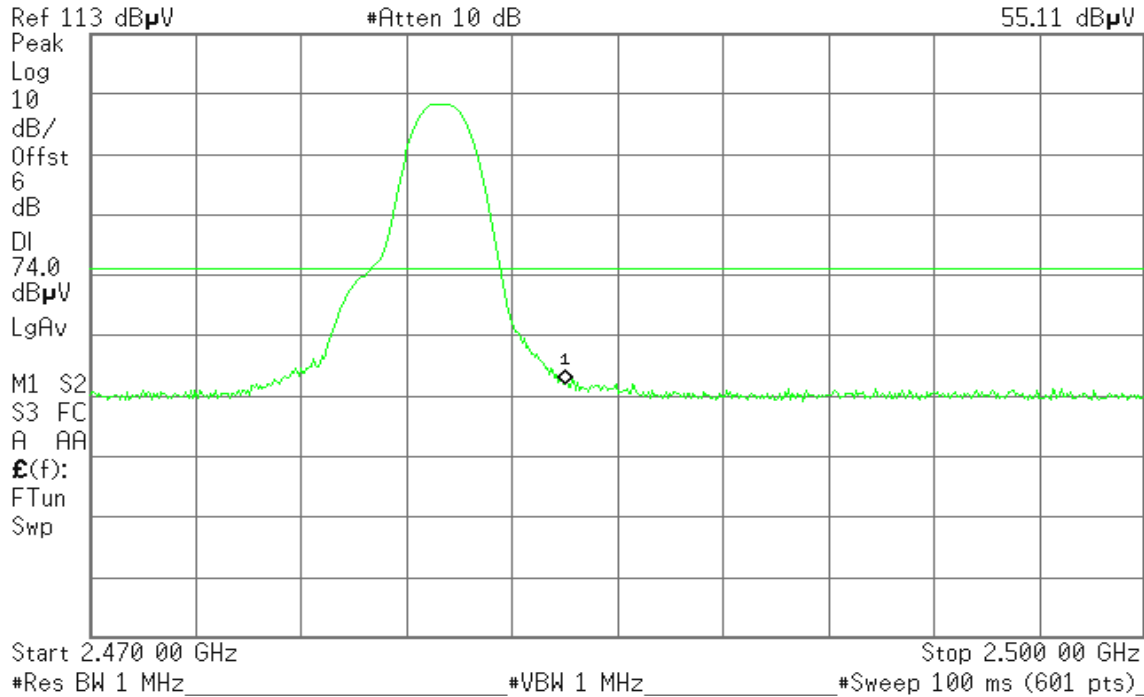

Detector mode: Average

Polarity: Horizontal

Agilent 16:00:31 Oct 7, 2010

R T

Mkr1 2.483 50 GHz
42.66 dB μ V

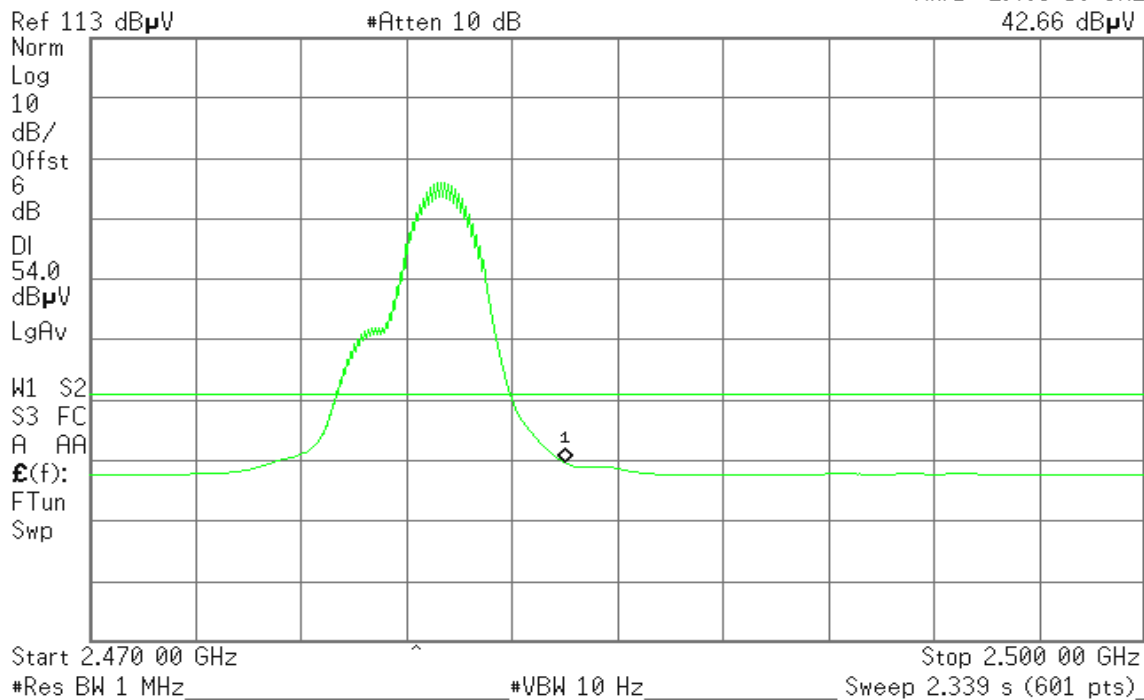



For 8DPSK / DH5

Band Edges (CH Low)

Detector mode: Peak

Polarity: Vertical

Agilent 10:06:37 Nov 15, 2010

R T

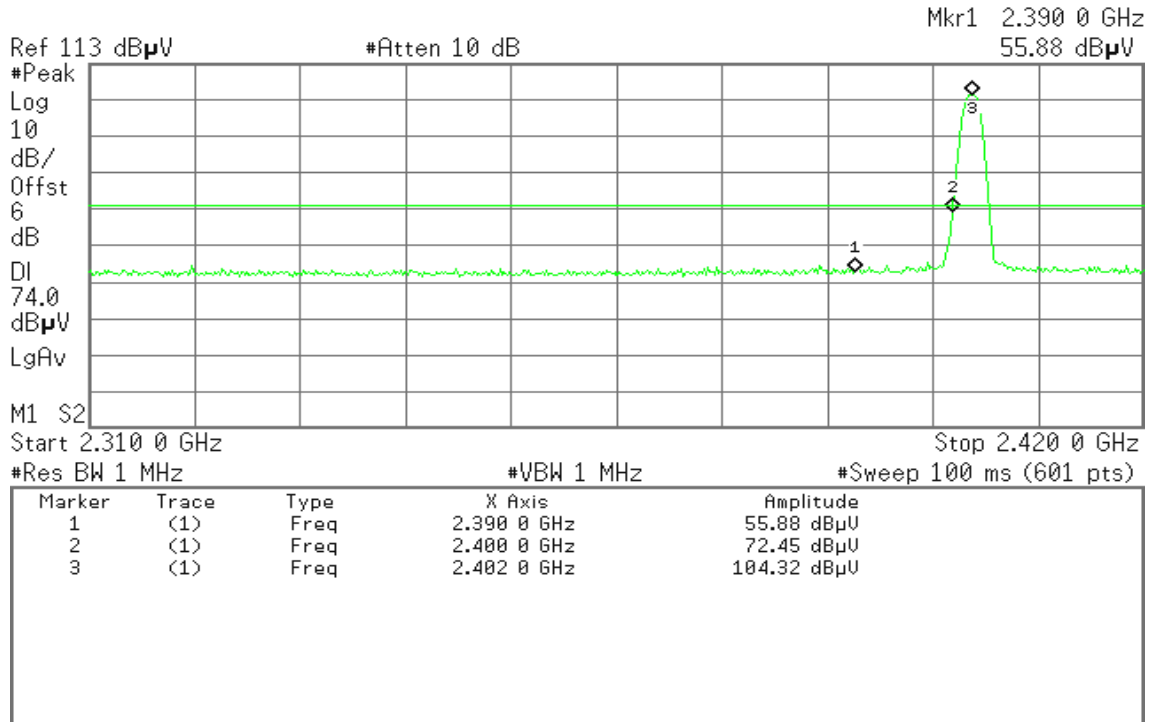

Detector mode: Average

Polarity: Vertical

Agilent 10:06:11 Nov 15, 2010

R T

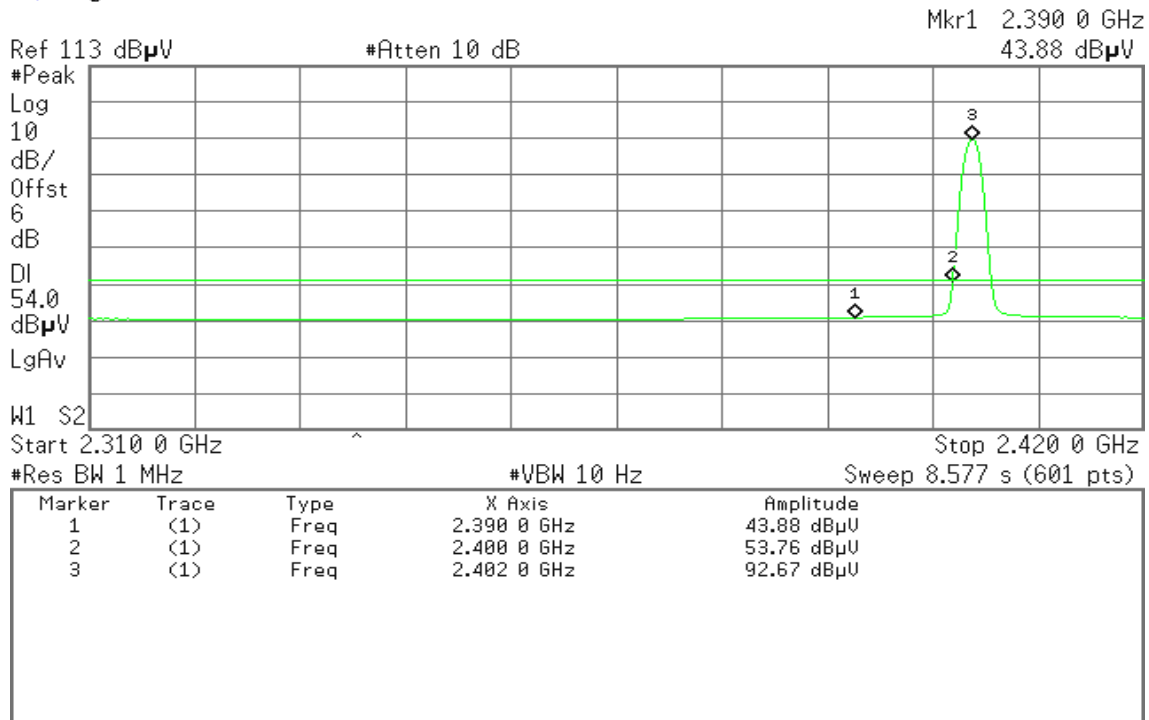



Detector mode: Peak

Polarity: Horizontal

Agilent 10:08:11 Nov 15, 2010

R T

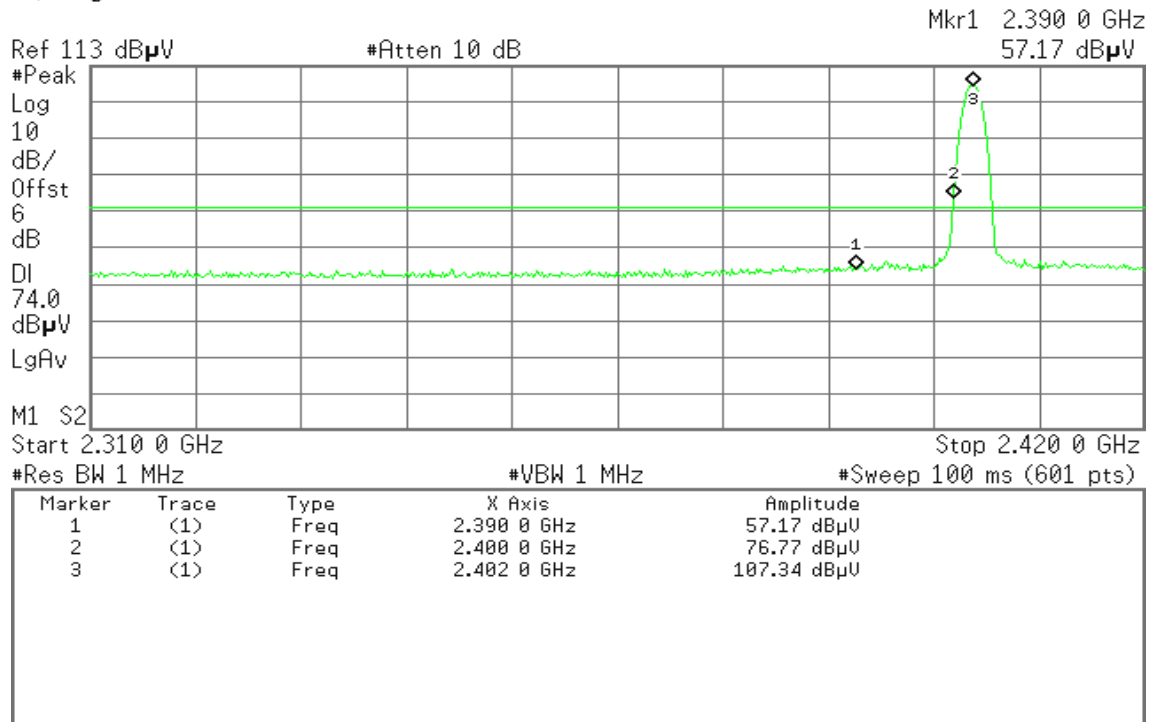

Detector mode: Average

Polarity: Horizontal

Agilent 10:07:43 Nov 15, 2010

R T

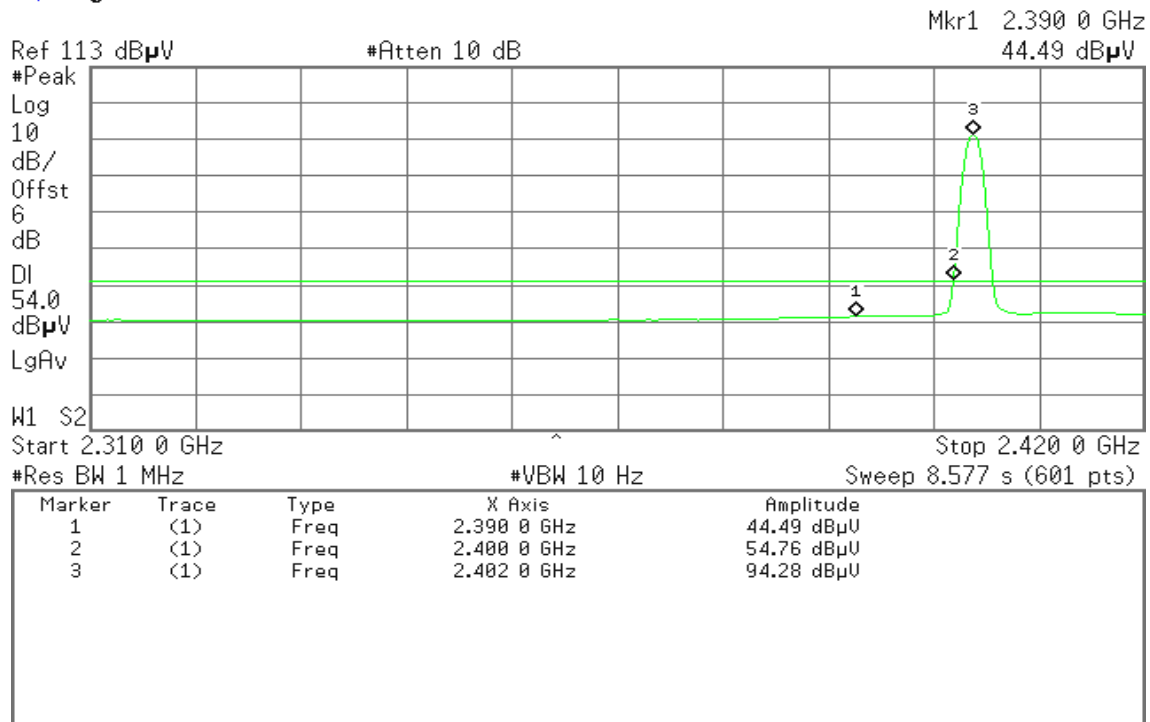



Band Edges (CH High)

Detector mode: Peak

Polarity: Vertical

Agilent 10:31:34 Nov 15, 2010

R T

Mkr1 2.483 50 GHz
54.74 dB μ V

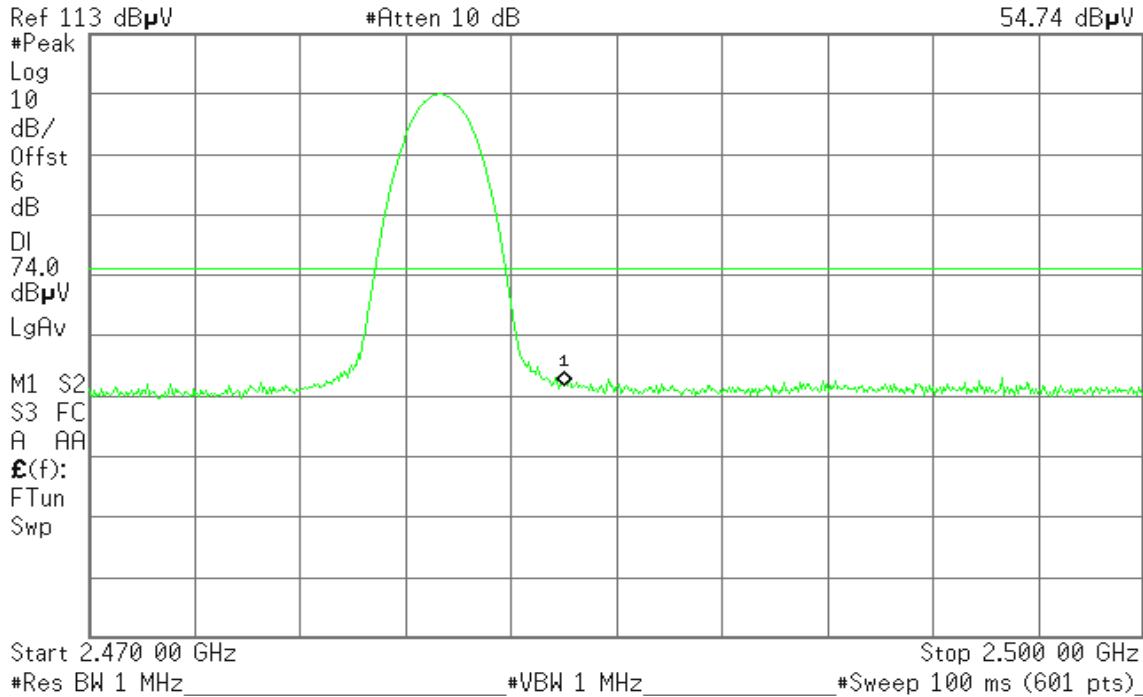

Detector mode: Average

Polarity: Vertical

Agilent 10:31:16 Nov 15, 2010

R T

Mkr1 2.483 50 GHz
42.74 dB μ V

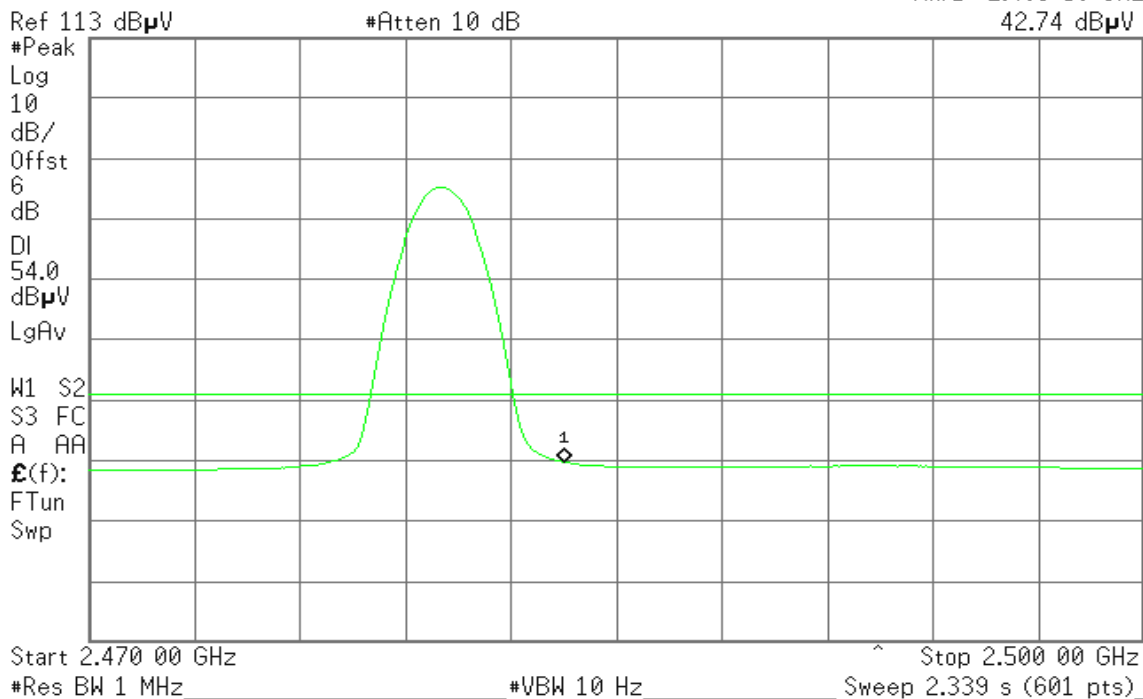



Detector mode: Peak

Polarity: Horizontal

Agilent 10:32:35 Nov 15, 2010

R T

Mkr1 2.483 50 GHz
57.15 dB μ V

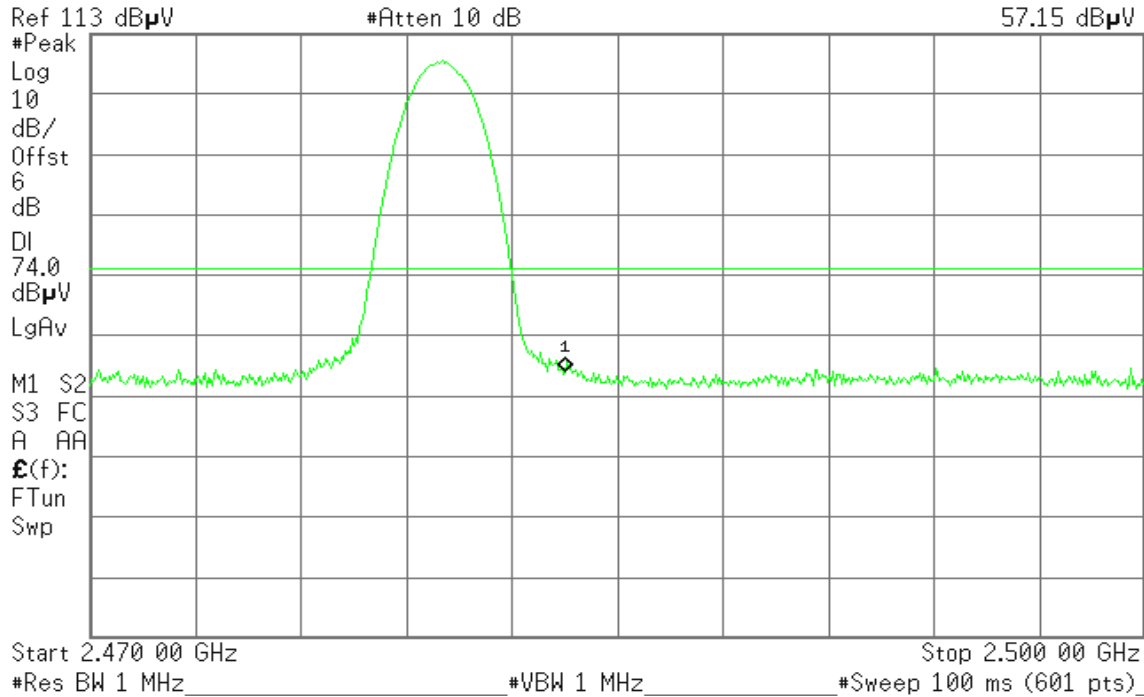

Detector mode: Average

Polarity: Horizontal

Agilent 10:33:01 Nov 15, 2010

R T

Mkr1 2.483 50 GHz
45.04 dB μ V

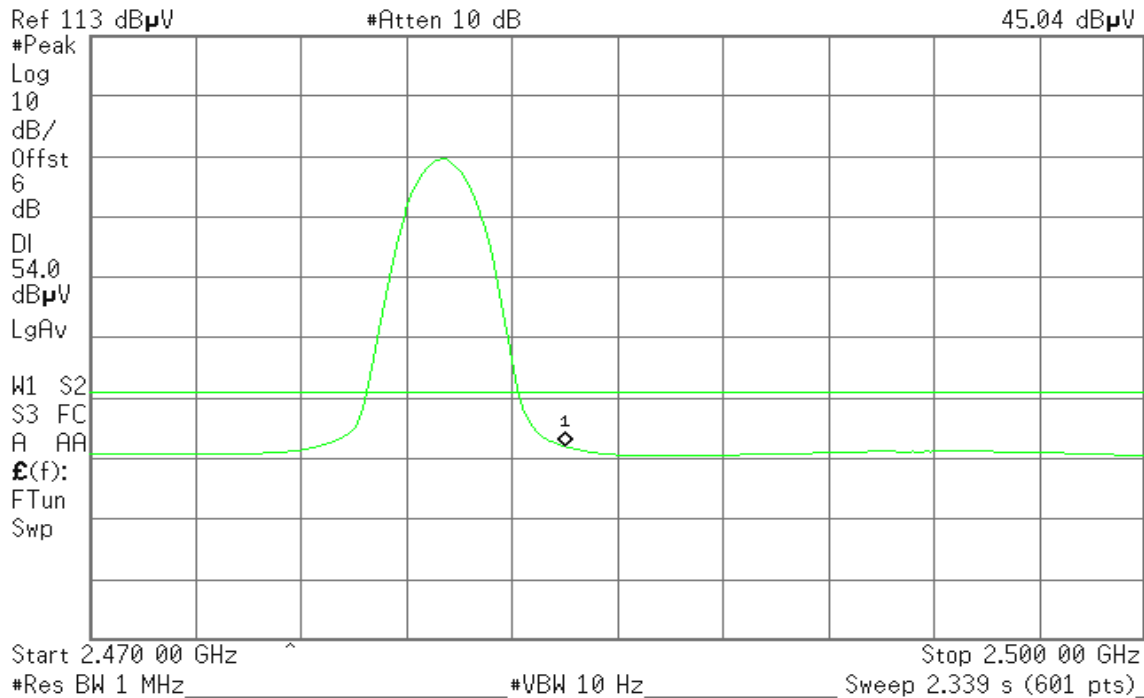



7.5 PEAK POWER SPECTRAL DENSITY

LIMIT

1. According to §15.247(e), for digitally modulated systems, the power spectral density conducted from the intentional radiator to the antenna shall not be greater than 8 dBm in any 3 kHz band during any time interval of continuous transmission.
2. According to §15.247(f), the digital modulation operation of the hybrid system, with the frequency hopping turned off, shall comply with the power density requirements of paragraph (d) of this section.

Test Configuration

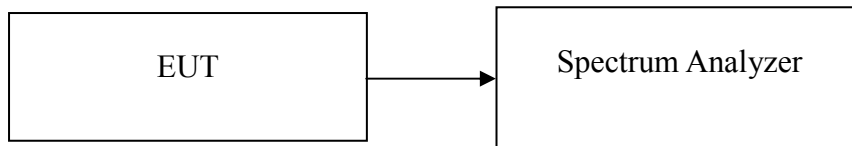

TEST PROCEDURE

1. Place the EUT on the table and set it in transmitting mode.
2. Remove the antenna from the EUT and then connect a low loss RF cable from the antenna port to the spectrum analyzer.
3. Set the spectrum analyzer as RBW = 3kHz, VBW = 10kHz, Span = 300kHz, Sweep=100s
4. Record the max. reading.
5. Repeat the above procedure until the measurements for all frequencies are completed.

TEST RESULTS

No non-compliance noted



Test Data

For GFSK / DH5

Channel	Frequency (MHz)	PPSD (dBm)	Limit (dBm)	Result
Low	2402	-12.04	8.00	PASS
Mid	2441	-12.17		PASS
High	2480	-11.81		PASS

For 8DPSK / DH5

Channel	Frequency (MHz)	PPSD (dBm)	Limit (dBm)	Result
Low	2402	-16.35	8.00	PASS
Mid	2441	-16.48		PASS
High	2480	-16.00		PASS



Test Plot

For GFSK / DH5

PPSD (CH Low)

Agilent 14:15:56 Oct 8, 2010

R T

Mkr1 2.401 946 9 GHz
-12.04 dBm

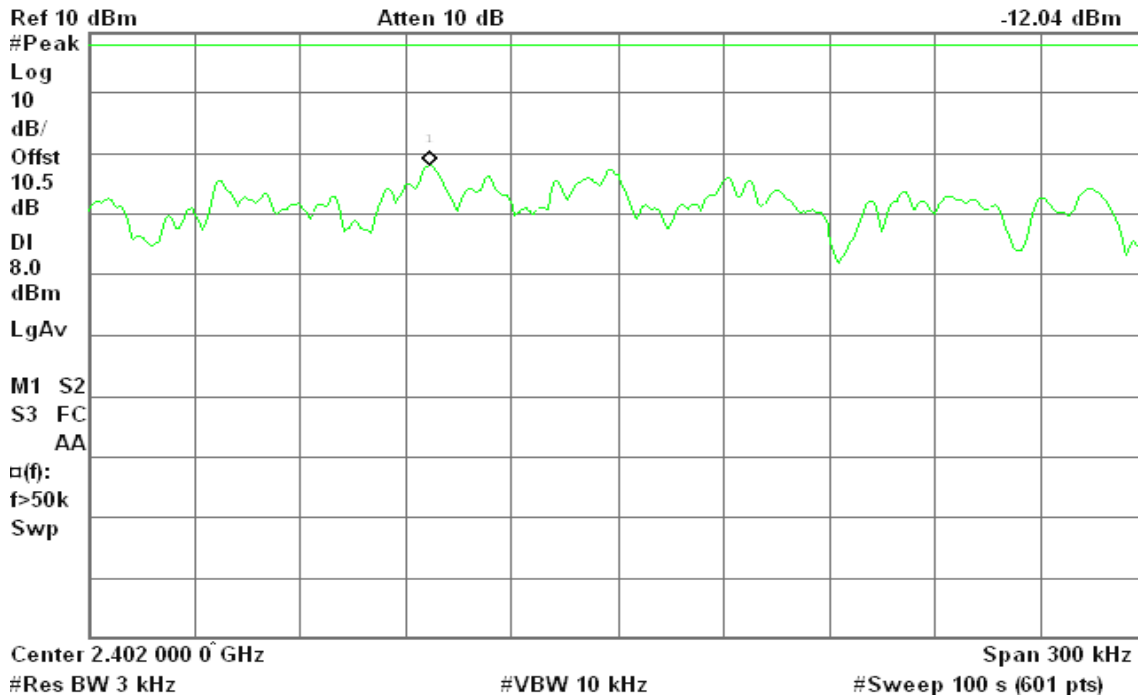

PPSD (CH Mid)

Agilent 14:13:31 Oct 8, 2010

R T

Mkr1 2.440 948 4 GHz
-12.17 dBm

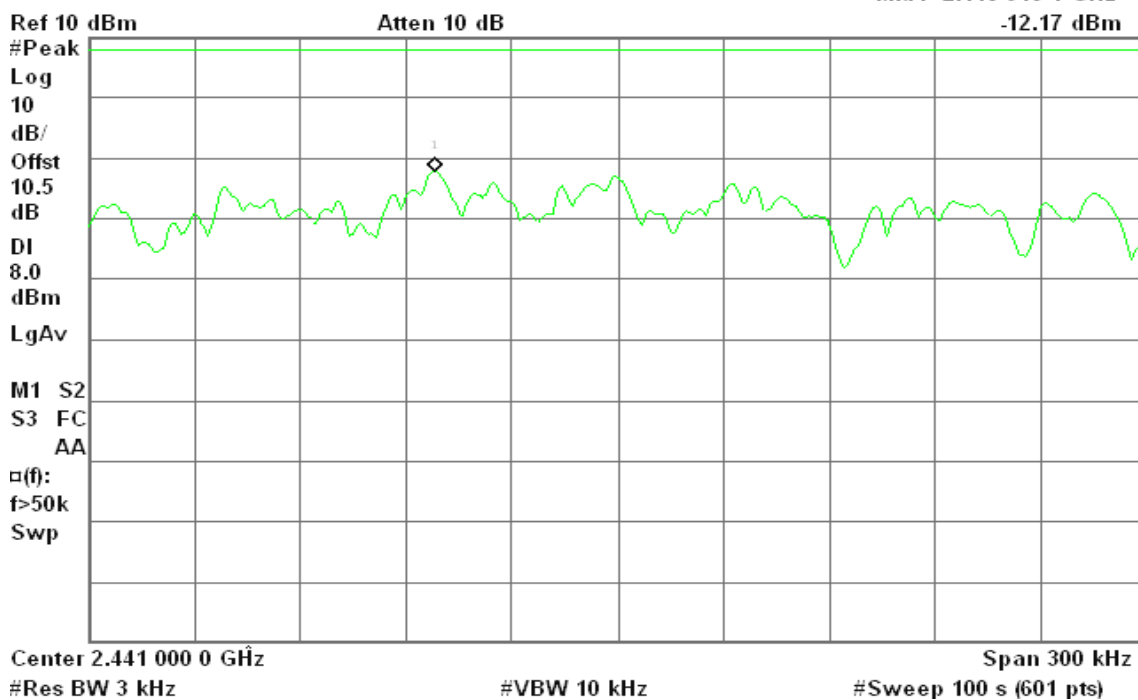



PPSD (CH High)

Agilent 14:11:02 Oct 8, 2010

R T

Mkr1 2.479 949 7 GHz

-11.81 dBm

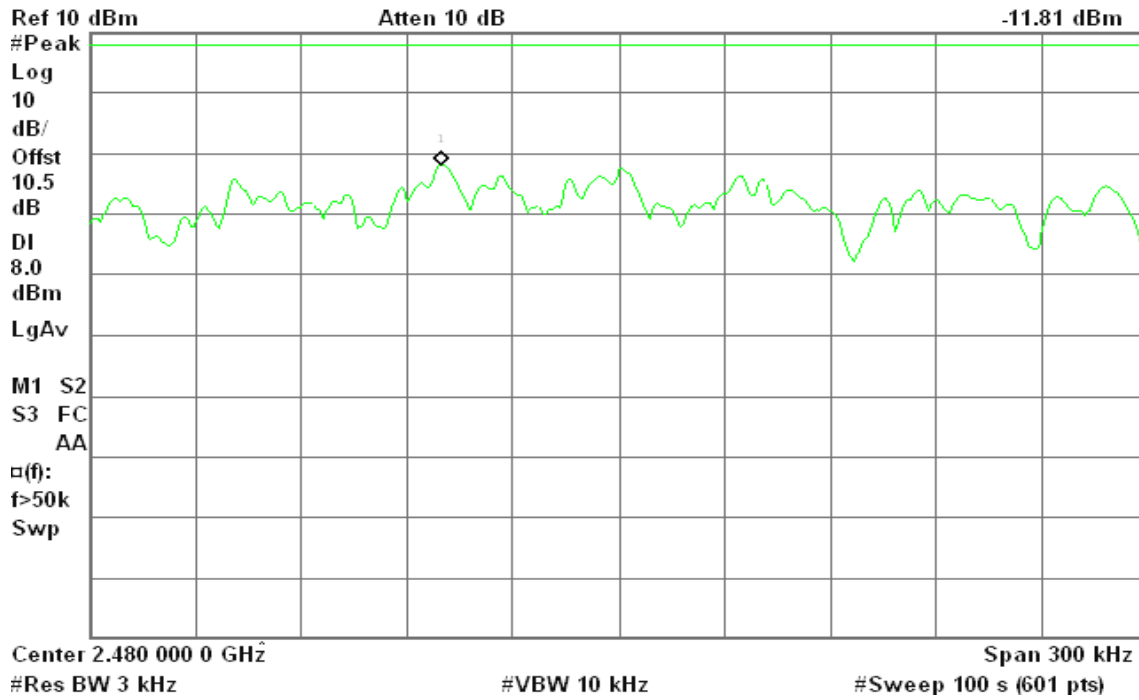



For 8DPSK / DH5

PPSD (CH Low)

Agilent 14:54:53 Oct 8, 2010

R T

Mkr1 2.401 959 4 GHz

-16.35 dBm

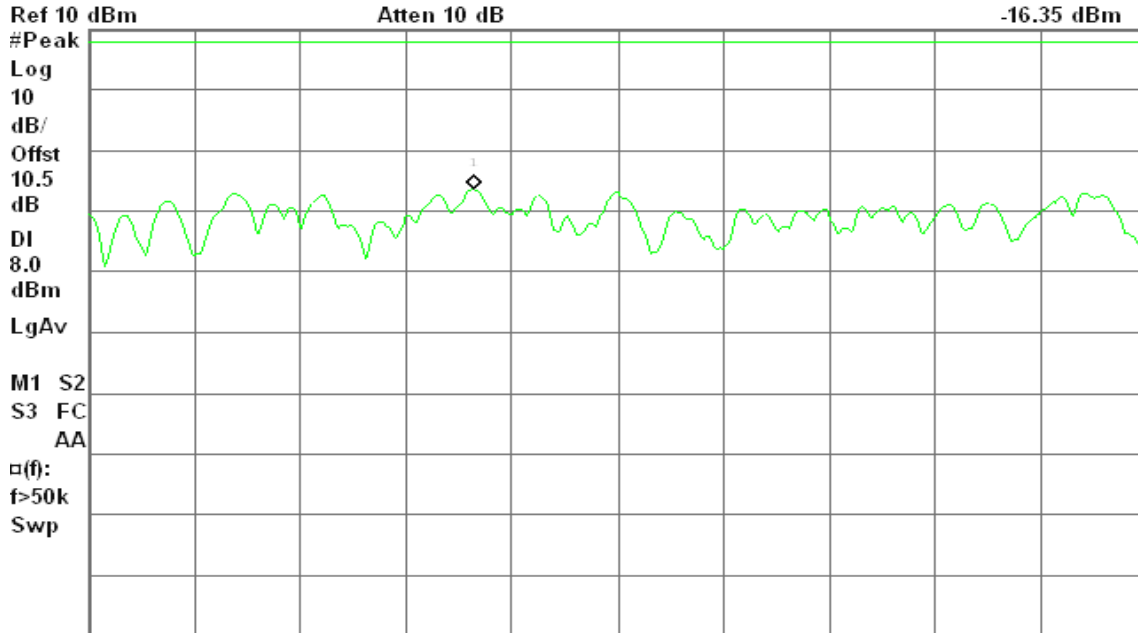

Center 2.402 000 0 GHz

Span 300 kHz

#Res BW 3 kHz

#VBW 10 kHz

#Sweep 100 s (601 pts)

PPSD (CH Mid)

Agilent 14:57:45 Oct 8, 2010

R T

Mkr1 2.440 960 9 GHz

-16.48 dBm

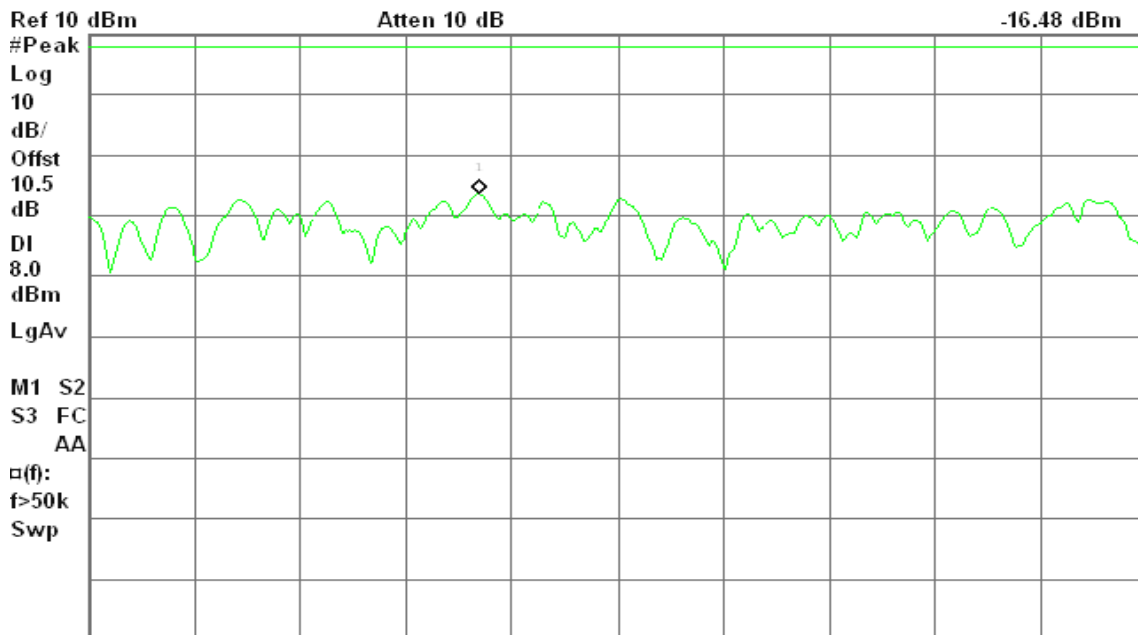

Center 2.441 000 0 GHz

Span 300 kHz

#Res BW 3 kHz

#VBW 10 kHz

#Sweep 100 s (601 pts)



PPSD (CH High)

Agilent 15:00:13 Oct 8, 2010

R T

Mkr1 2.479 963 3 GHz

-16.00 dBm

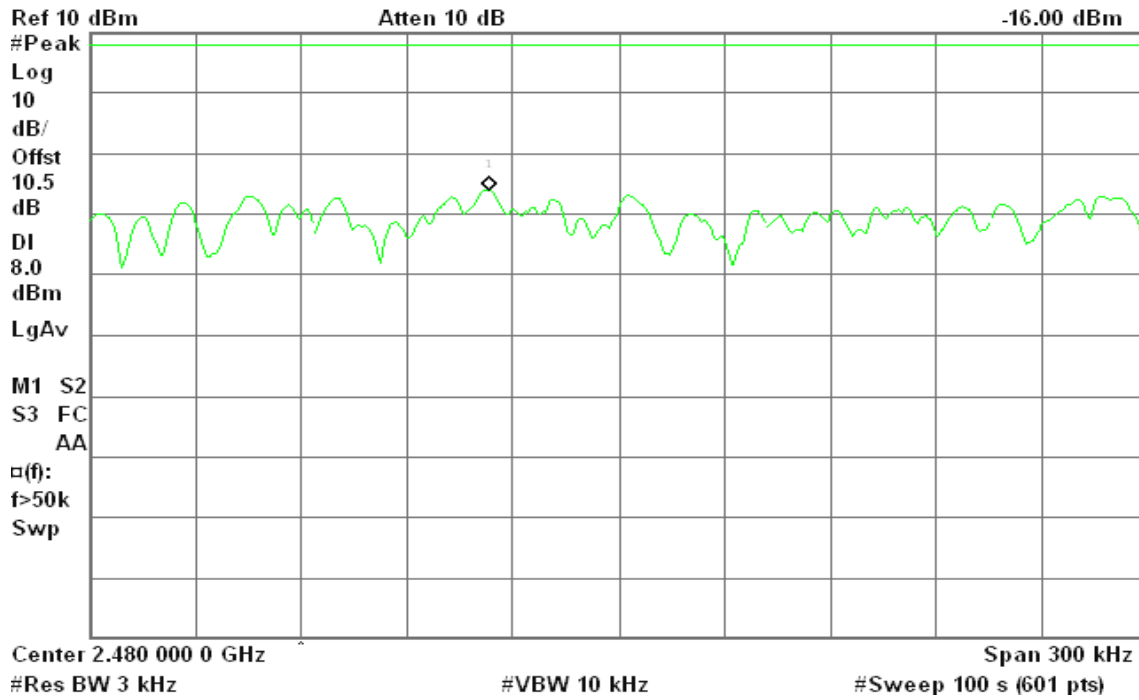



7.6 FREQUENCY SEPARATION

LIMIT

According to §15.247(a)(1), Frequency hopping systems shall have hopping channel carrier frequencies separated by a minimum of 25 kHz or the 20 dB bandwidth of the hopping channel, whichever is greater. Alternatively, frequency hopping systems operating in the 2400-2483.5 MHz band may have hopping channel carrier frequencies that are separated by 25 kHz or two-thirds of the 20 dB bandwidth of the hopping channel, whichever is greater, provided the systems operate with an output power no greater than 125 mW.

Test Configuration

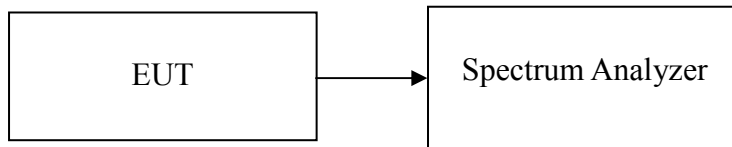

TEST PROCEDURE

1. Place the EUT on the table and set it in transmitting mode.
2. Remove the antenna from the EUT and then connect a low loss RF cable from the antenna port to the spectrum analyzer.
3. Set center frequency of spectrum analyzer = middle of hopping channel.
4. Set the spectrum analyzer as for RBW=30 kHz, VBW = 100 kHz, Span = 3MHz, Sweep = auto.
5. Max hold, mark 3 peaks of hopping channel and record the 3 peaks frequency.

TEST RESULTS

No non-compliance noted

Test Data

For GFSK / DH5

Channel Separation (MHz)	two-thirds of the 20 dB bandwidth (kHz)	Channel Separation Limit	Result
1.00	612	>two-thirds of the 20 dB bandwidth	Pass

For 8DPSK / DH5

Channel Separation (MHz)	two-thirds of the 20 dB bandwidth (kHz)	Channel Separation Limit	Result
1.00	856	>two-thirds of the 20 dB bandwidth	Pass



Test Plot

For GFSK / DH5

Measurement of Channel Separation

Agilent 15:44:28 Oct 8, 2010

R T

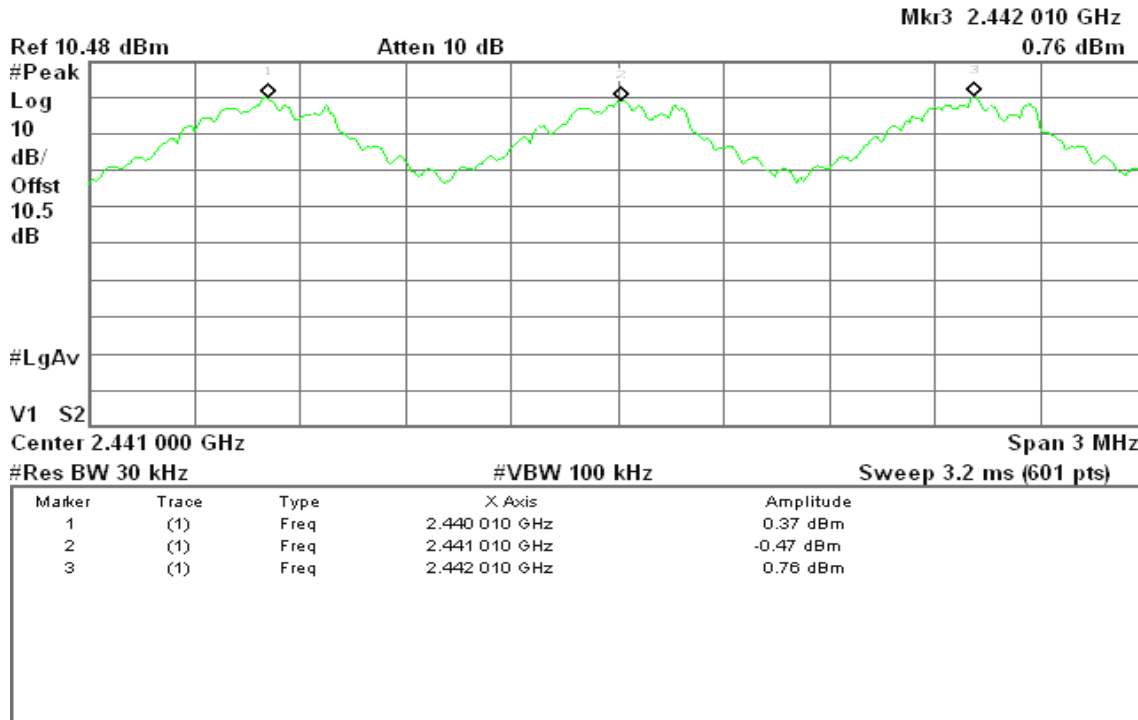

Measurement of 20dB Bandwidth

Agilent 15:28:18 Oct 8, 2010

R T

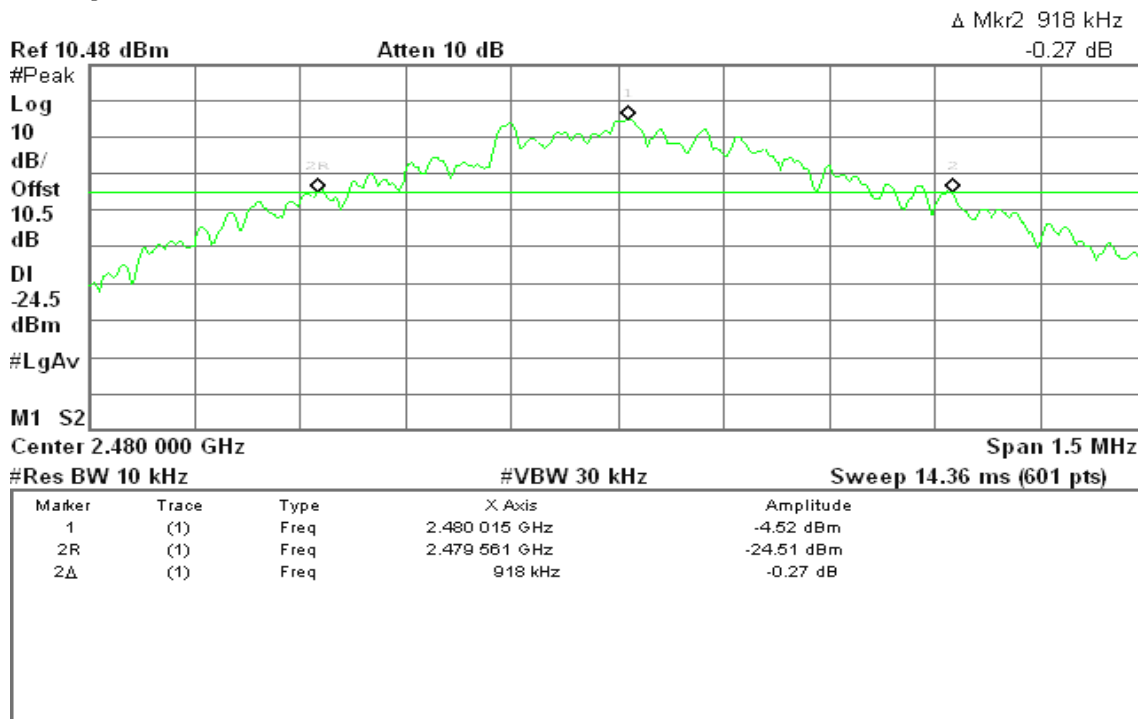



For 8DPSK / DH5

Measurement of Channel Separation

Agilent 16:41:29 Oct 8, 2010

R T

Mkr1 2.440 010 GHz

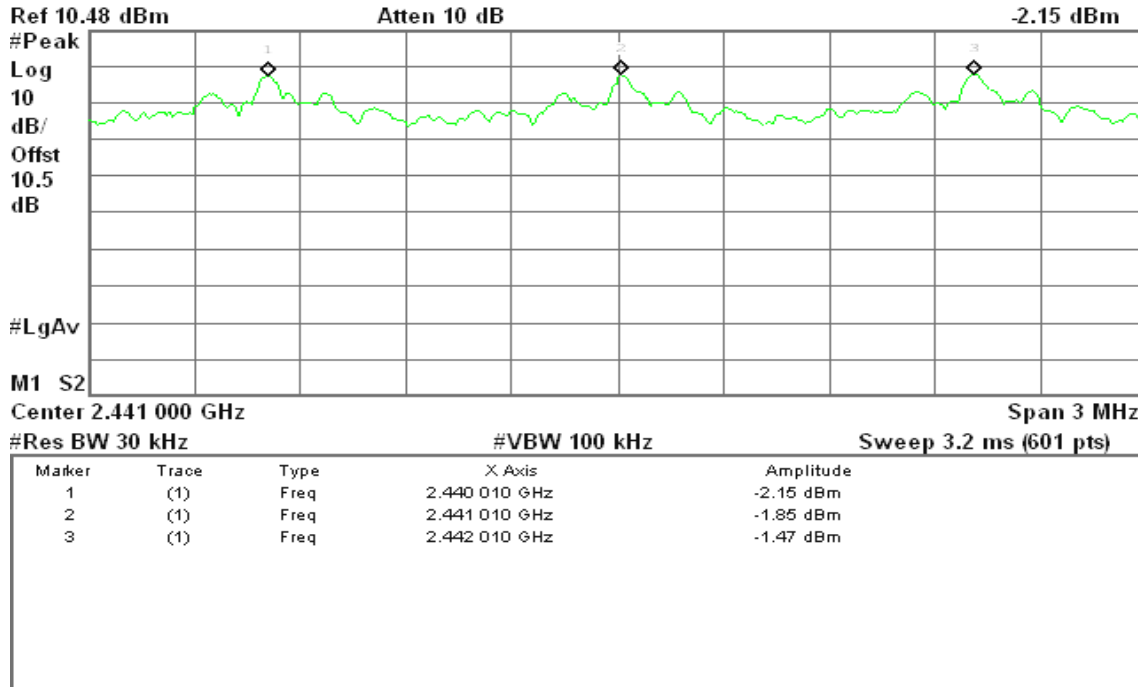

Measurement of 20dB Bandwidth

Agilent 15:48:23 Oct 8, 2010

R T

Δ Mkr2 1.285 MHz

1.07 dB

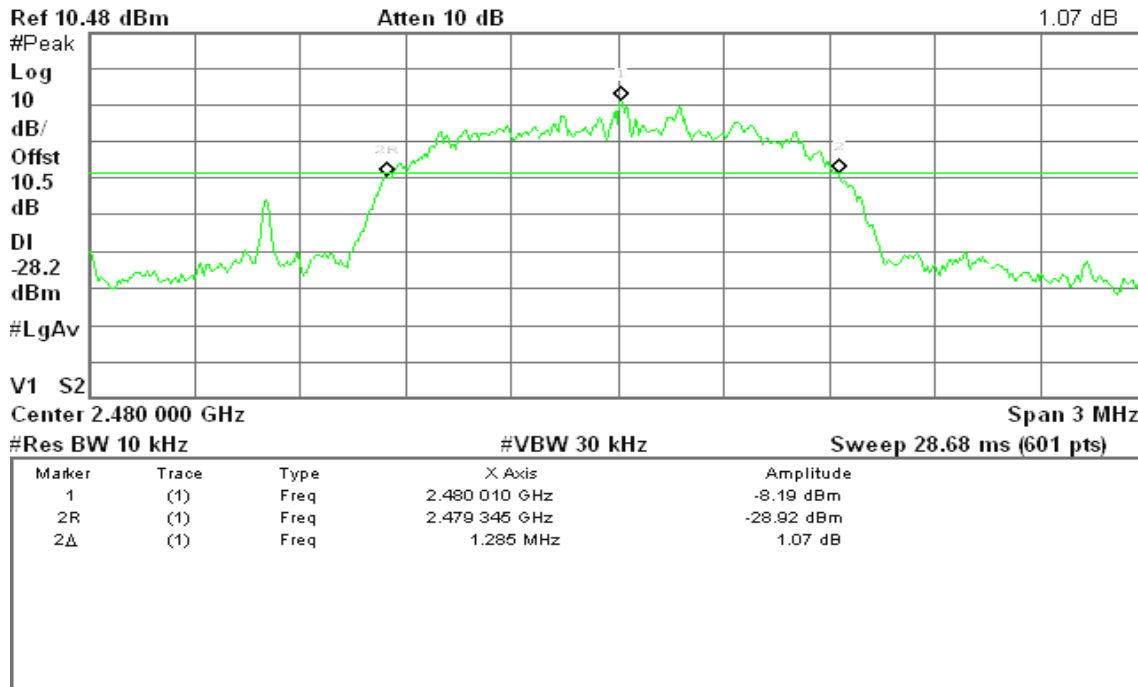



7.7 NUMBER OF HOPPING FREQUENCY

LIMIT

According to §15.247(a)(1)(iii), Frequency hopping systems operating in the 2400MHz-2483.5 MHz bands shall use at least 15 hopping frequencies.

Test Configuration

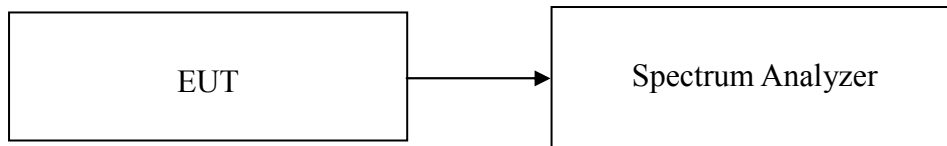

TEST PROCEDURE

1. Place the EUT on the table and set it in transmitting mode.
2. Remove the antenna from the EUT and then connect a low loss RF cable from the antenna port to the spectrum analyzer.
3. Set spectrum analyzer Start=2400MHz, Stop = 2441.5MHz, Sweep = auto and Start=2441.5MHz, Stop = 2483.5MHz, Sweep = auto.
4. Set the spectrum analyzer as RBW, VBW=510kHz.
5. Max hold, view and count how many channel in the band.

TEST RESULTS

No non-compliance noted

Test Data

For GFSK / 8DPSK

Result (No. of CH)	Limit (No. of CH)	Result
79	>15	PASS



Test Plot

For GFSK

Channel Number

2.4 GHz – 2.4415 GHz

Agilent 15:39:11 Oct 8, 2010

R T

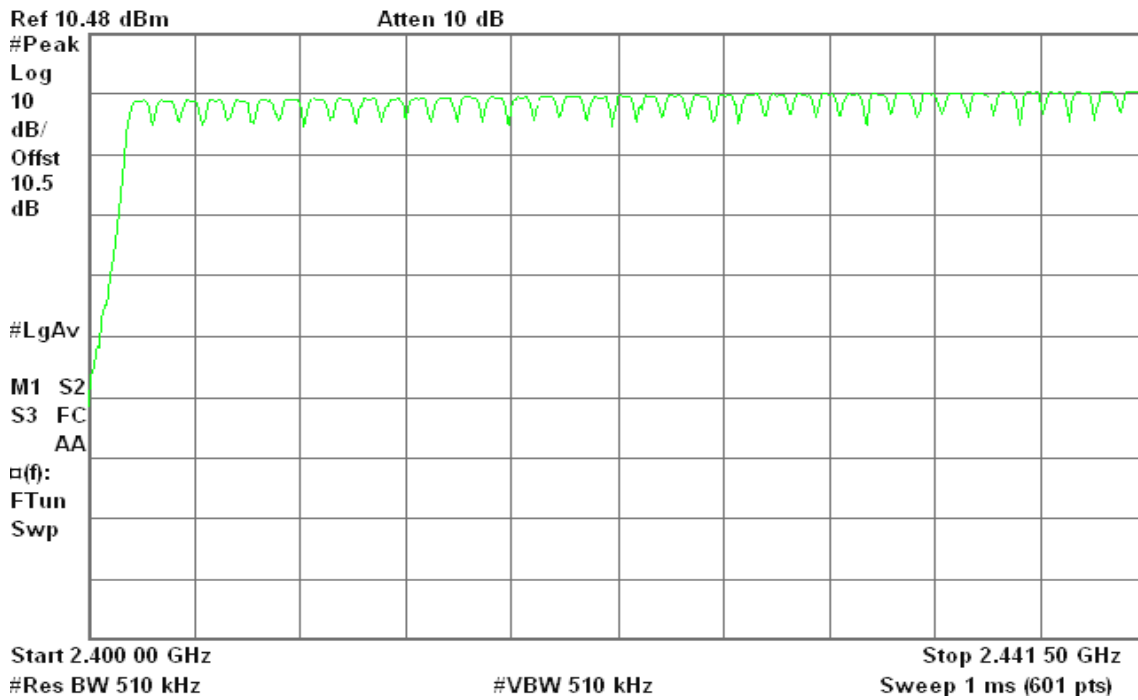

2.4415 GHz – 2.4835 GHz

Agilent 15:39:30 Oct 8, 2010

R T

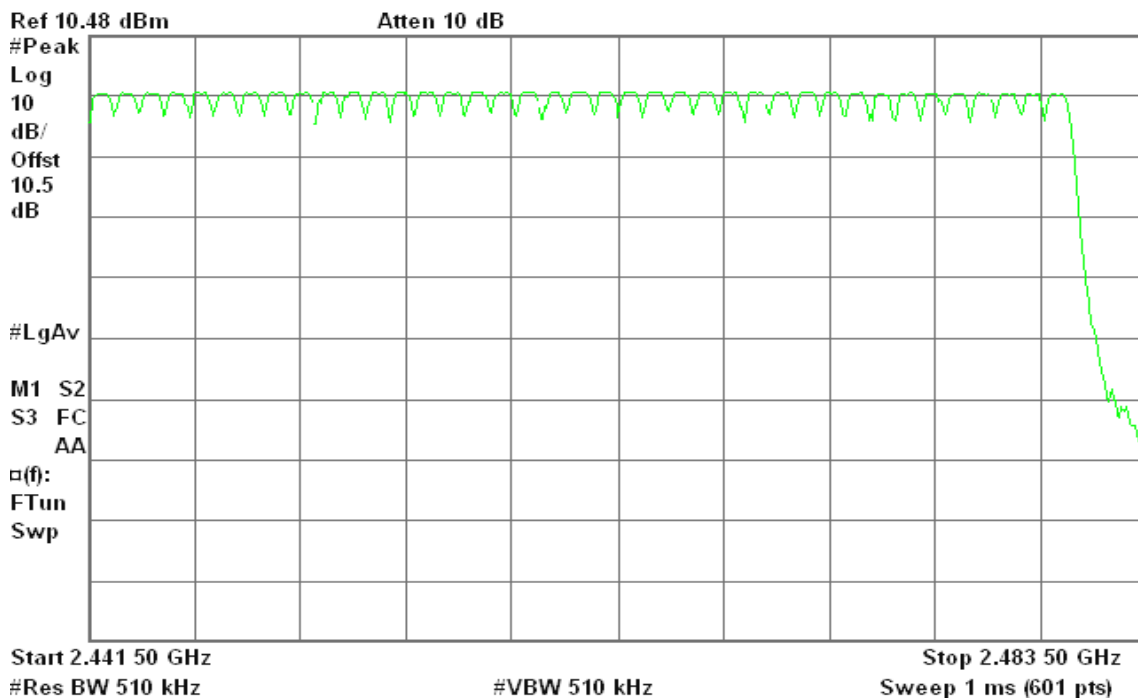



For 8DPSK

Channel Number

2.4 GHz – 2.4415 GHz

* Agilent 16:25:45 Oct 8, 2010

R T

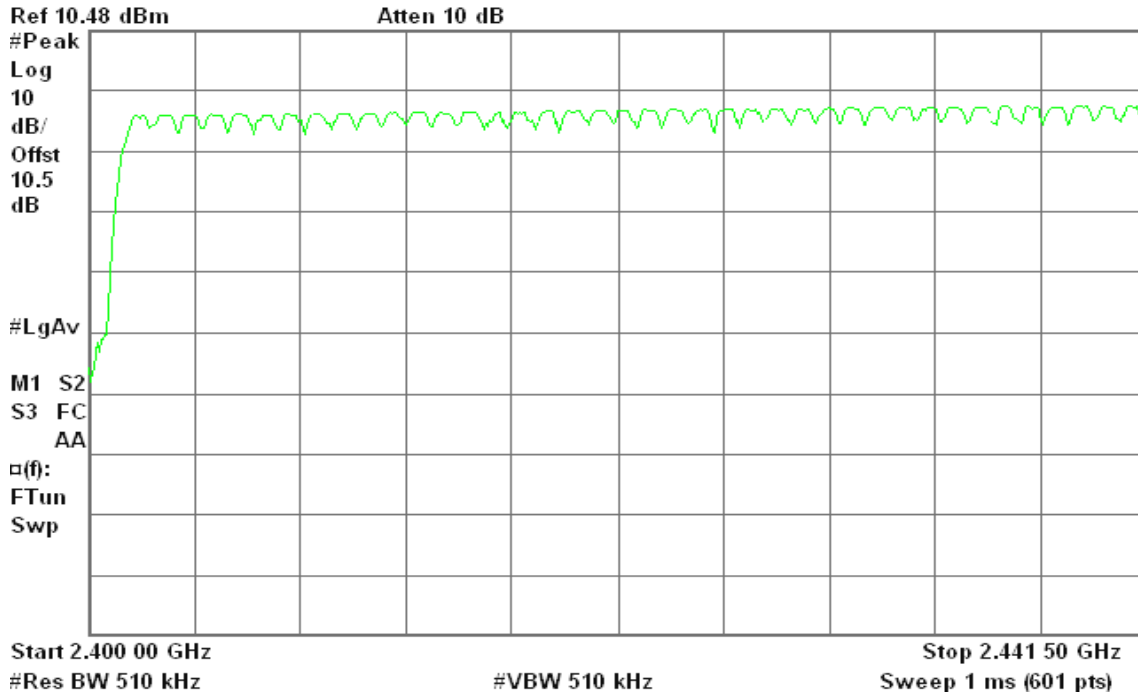

2.4415 GHz – 2.4835 GHz

* Agilent 16:27:39 Oct 8, 2010

R T

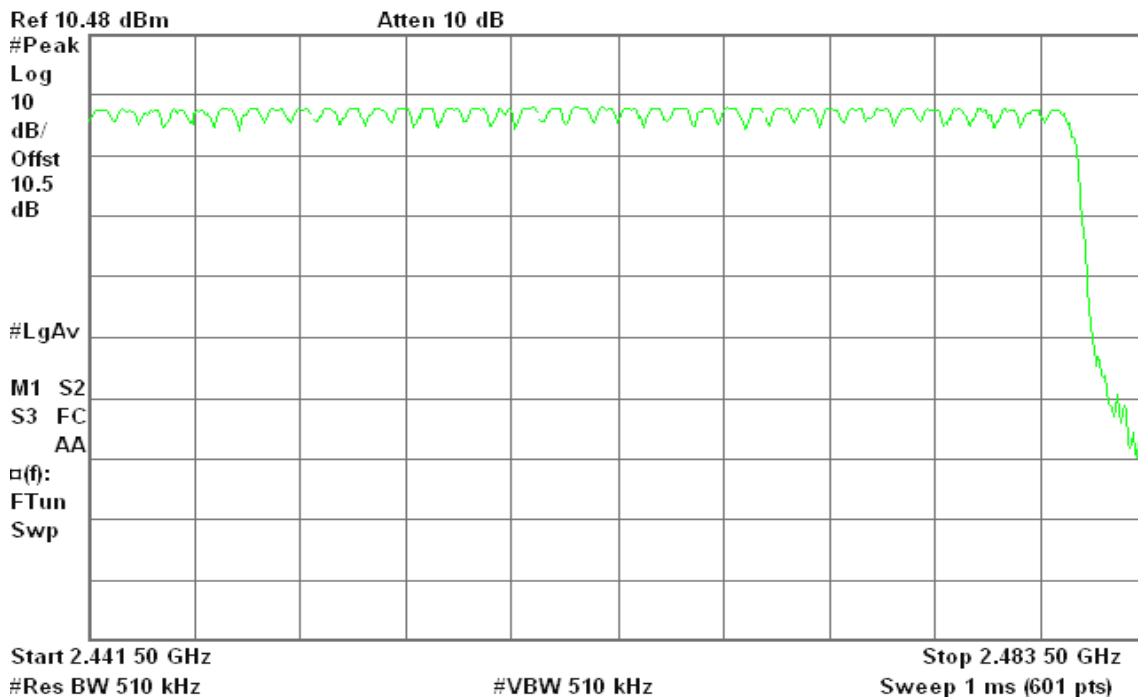



7.8 TIME OF OCCUPANCY (DWELL TIME)

LIMIT

According to §15.247(a)(1)(iii), Frequency hopping systems operating in the 2400MHz-2483.5 MHz bands. The average time of occupancy on any channels shall not greater than 0.4 s within a period 0.4 s multiplied by the number of hopping channels employed.

Test Configuration

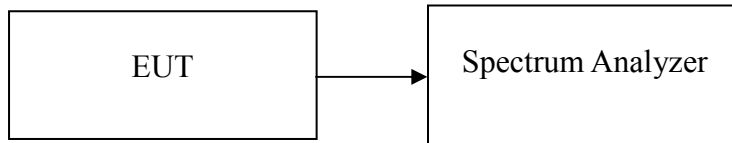

TEST PROCEDURE

1. Place the EUT on the table and set it in transmitting mode.
2. Remove the antenna from the EUT and then connect a low loss RF cable from the antenna port to the spectrum analyzer.
3. Set center frequency of spectrum analyzer = operating frequency.
4. Set the spectrum analyzer as RBW=1MHz, VBW=1MHz, Span = 0Hz, Sweep = auto.
5. Repeat above procedures until all frequency measured were complete.



Test Data

For GFSK

DH 1

CH Low: $0.400 * (1600/2)/79 * 31.6 = 128.000$ (ms)

CH Mid: $0.400 * (1600/2)/79 * 31.6 = 128.000$ (ms)

CH High: $0.400 * (1600/2)/79 * 31.6 = 128.000$ (ms)

CH	Pulse Time (ms)	Total of Dwell (ms)	Period Time (s)	Limit (ms)	Result
Low	0.400	128.000	31.60	400.00	PASS
Mid	0.400	128.000	31.60		PASS
High	0.400	128.000	31.60		PASS

DH 3

CH Low: $1.667 * (1600/4)/79 * 31.6 = 266.720$ (ms)

CH Mid: $1.633 * (1600/4)/79 * 31.6 = 261.280$ (ms)

CH High: $1.650 * (1600/4)/79 * 31.6 = 264.400$ (ms)

CH	Pulse Time (ms)	Total of Dwell (ms)	Period Time (s)	Limit (ms)	Result
Low	1.667	266.720	31.60	400.00	PASS
Mid	1.633	261.280	31.60		PASS
High	1.650	264.000	31.60		PASS

DH 5

CH Low: $2.900 * (1600/6)/79 * 31.6 = 309.333$ (ms)

CH Mid: $2.900 * (1600/6)/79 * 31.6 = 309.333$ (ms)

CH High: $2.917 * (1600/6)/79 * 31.6 = 311.147$ (ms)

CH	Pulse Time (ms)	Total of Dwell (ms)	Period Time (s)	Limit (ms)	Result
Low	2.900	309.333	31.60	400.00	PASS
Mid	2.900	309.333	31.60		PASS
High	2.917	311.147	31.60		PASS



Test Plot

For GFSK

DH 1

CH Low

Agilent 15:37:09 Oct 8, 2010

R T

Δ Mkr1 400 μs
-0.02 dB

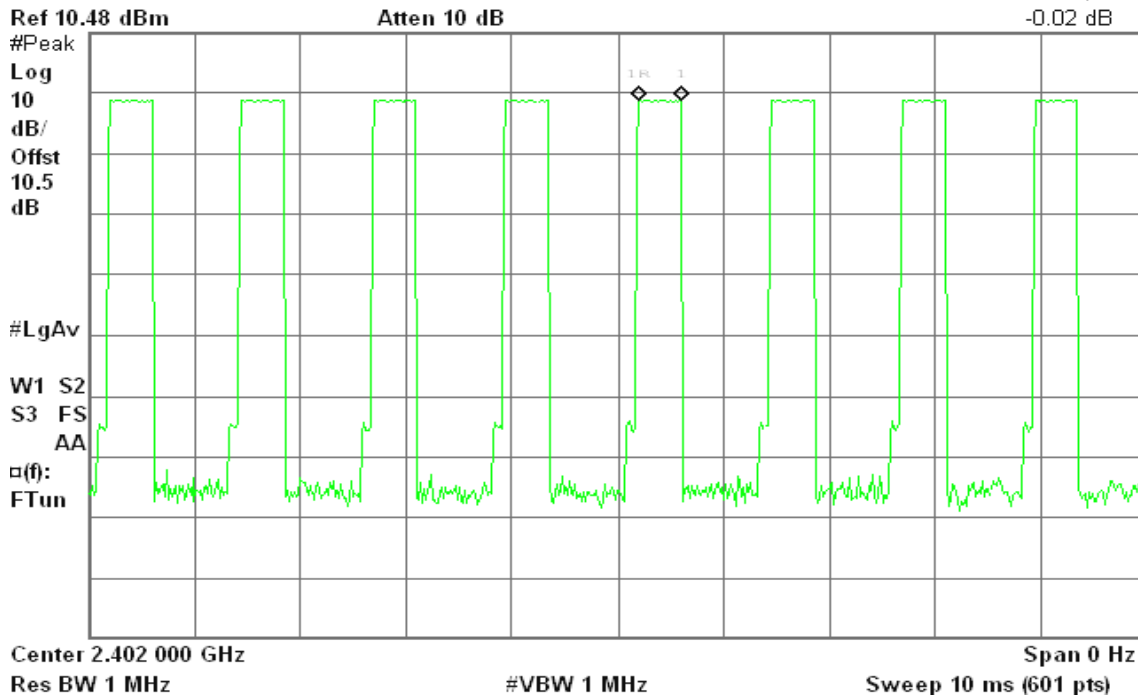

CH Mid

Agilent 15:36:41 Oct 8, 2010

R T

Δ Mkr1 400 μs
-0.07 dB

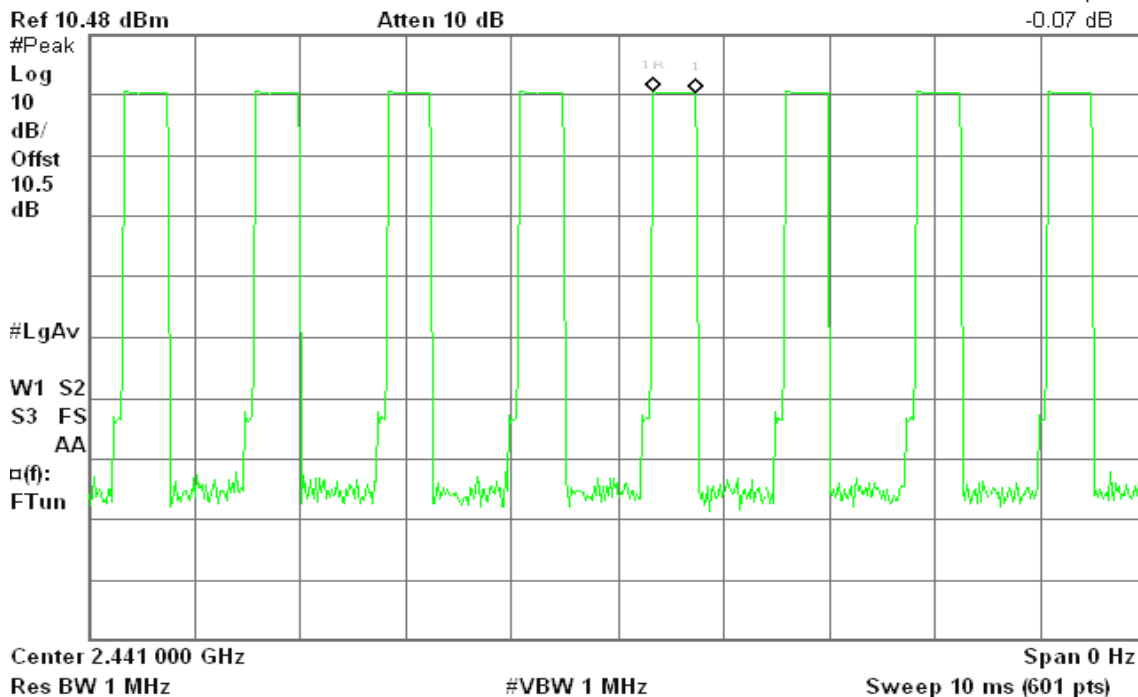



CH High

Agilent 15:34:03 Oct 8, 2010

R T

Δ Mkr1 400 μs
-0.59 dB

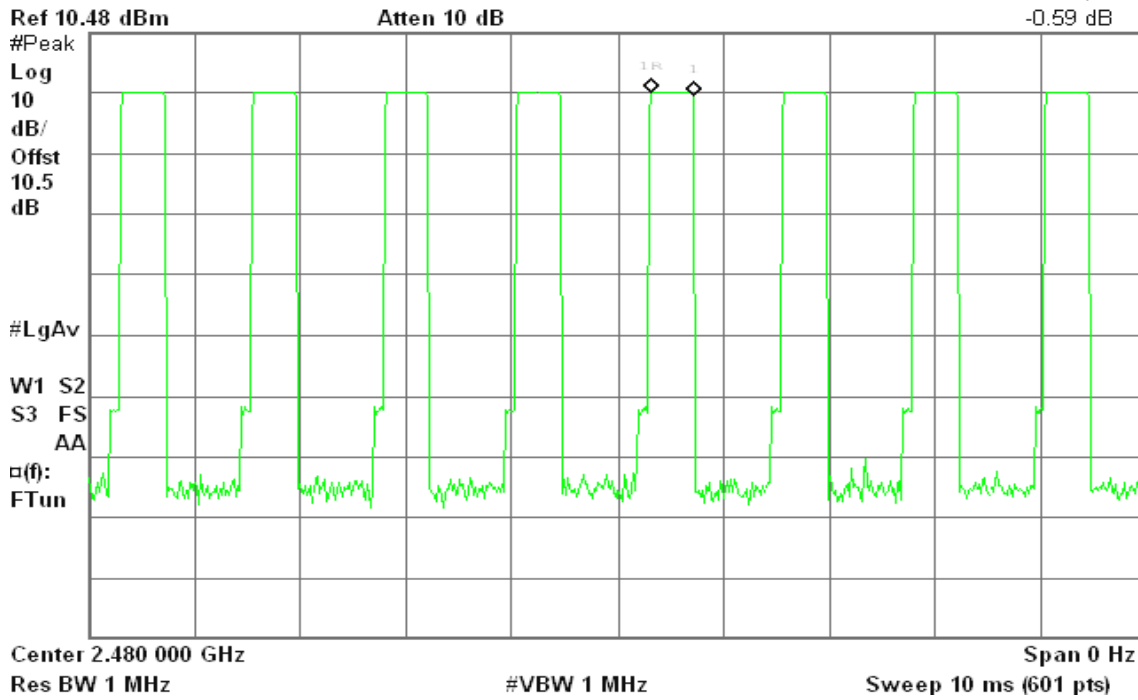

DH 3

CH Low

Agilent 15:37:45 Oct 8, 2010

R T

Δ Mkr1 1.667 ms
-0.88 dB

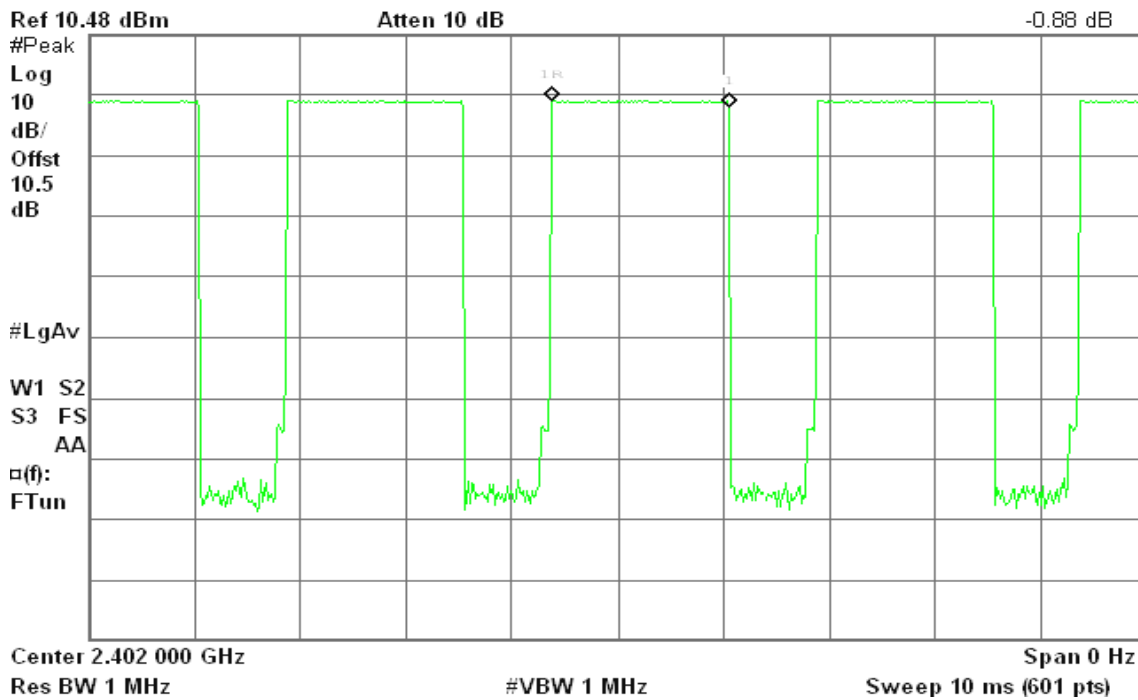



CH Mid

Agilent 15:36:16 Oct 8, 2010

R T

Δ Mkr1 1.633 ms
-0.04 dB

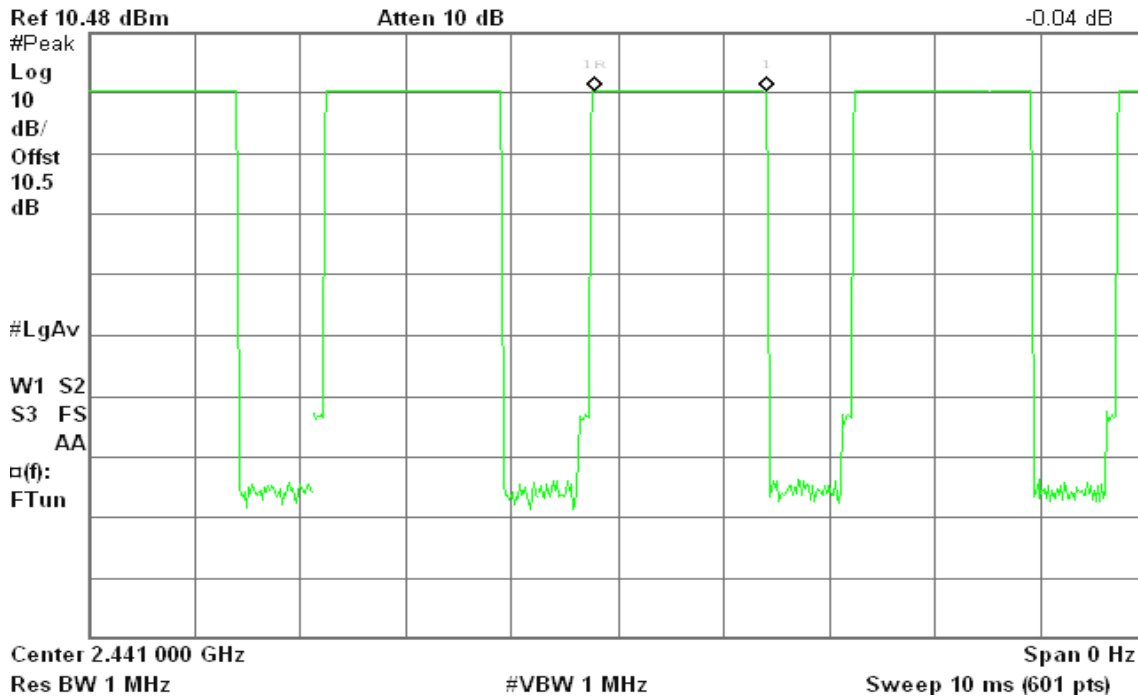

CH High

Agilent 15:34:33 Oct 8, 2010

R T

Δ Mkr1 1.65 ms
-0.04 dB

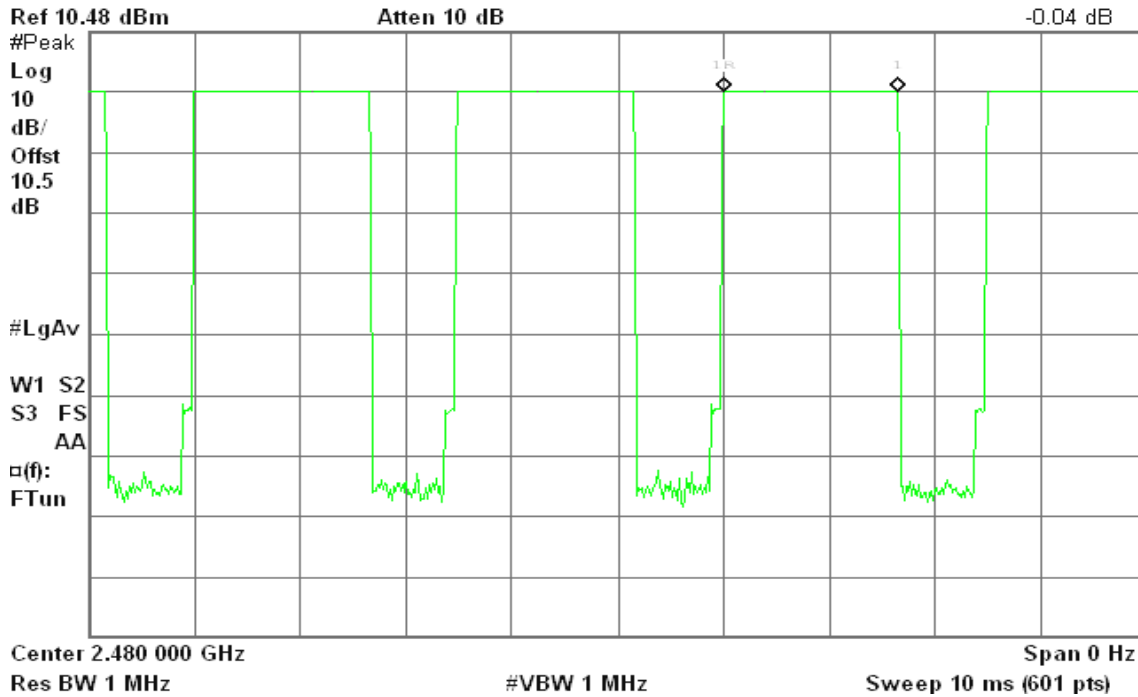



DH 5

CH Low

Agilent 15:38:13 Oct 8, 2010

R T

Δ Mkr1 2.9 ms
-0.06 dB

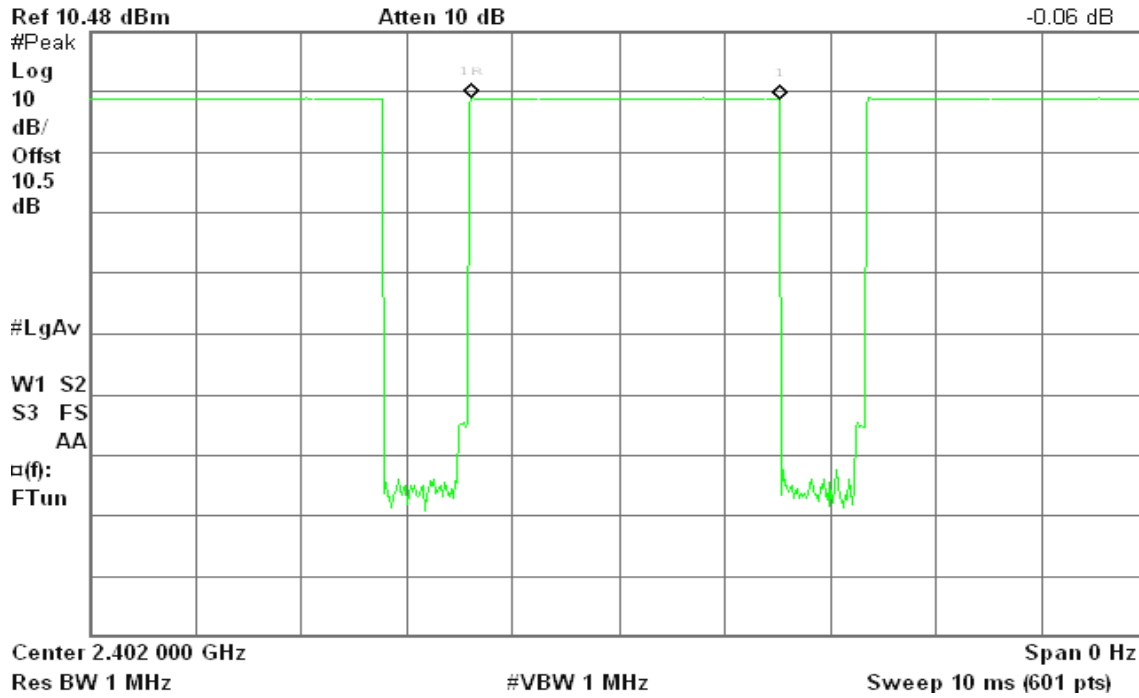

CH Mid

Agilent 15:35:44 Oct 8, 2010

R T

Δ Mkr1 2.9 ms
-0.02 dB

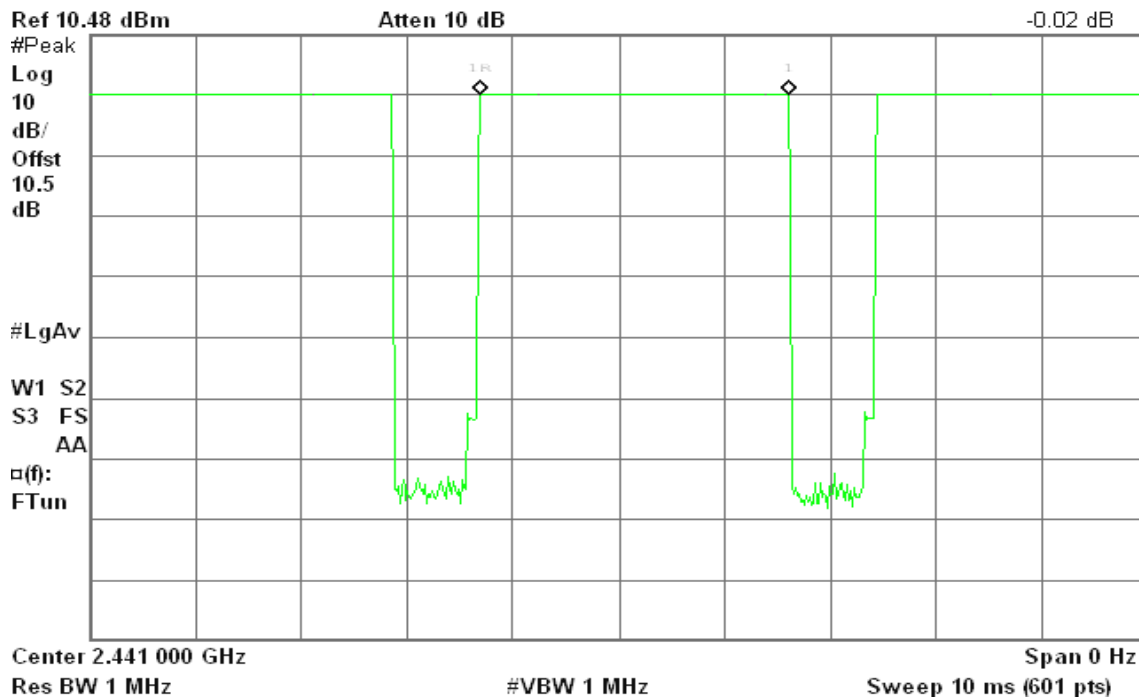



CH High

Agilent 15:35:09 Oct 8, 2010

R T

Δ Mkr1 2.917 ms
-0.01 dB

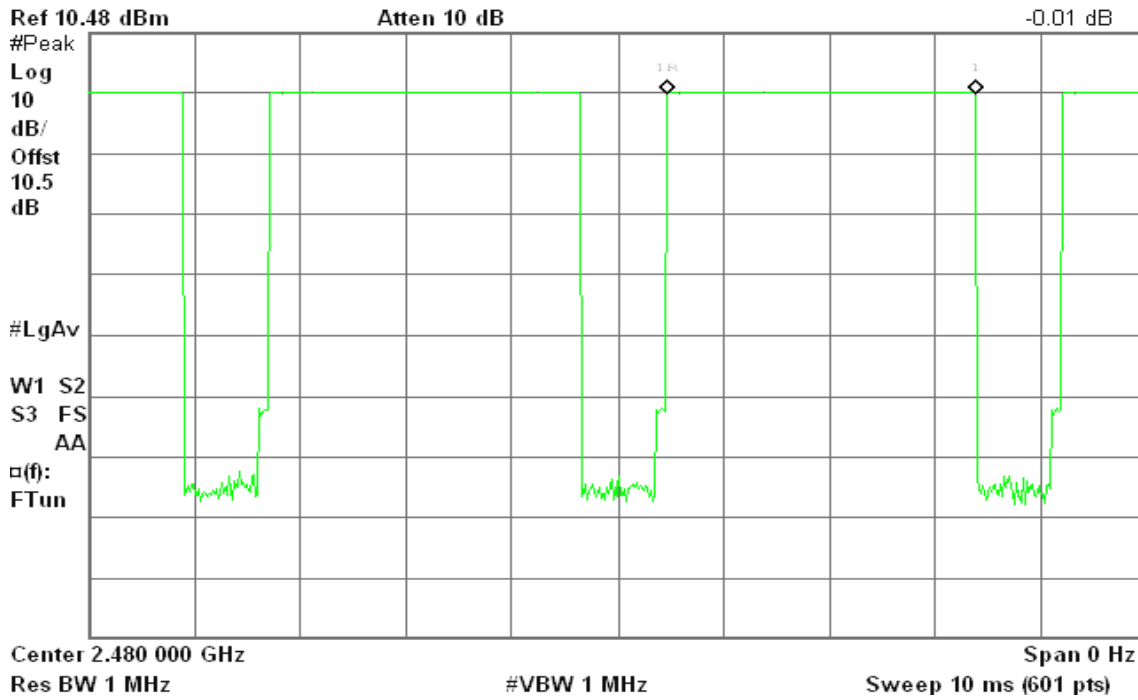



Test Data

For 8DPSK

DH 1

CH Low: $0.383 * (1600/2)/79 * 31.6 = 122.560$ (ms)

CH Mid: $0.400 * (1600/2)/79 * 31.6 = 128.000$ (ms)

CH High: $0.400 * (1600/2)/79 * 31.6 = 128.000$ (ms)

CH	Pulse Time (ms)	Total of Dwell (ms)	Period Time (s)	Limit (ms)	Result
Low	0.383	122.560	31.60	400.00	PASS
Mid	0.400	128.000	31.60		PASS
High	0.400	128.000	31.60		PASS

DH 3

CH Low: $1.917 * (1600/4)/79 * 31.6 = 306.720$ (ms)

CH Mid: $1.650 * (1600/4)/79 * 31.6 = 264.000$ (ms)

CH High: $1.633 * (1600/4)/79 * 31.6 = 261.280$ (ms)

CH	Pulse Time (ms)	Total of Dwell (ms)	Period Time (s)	Limit (ms)	Result
Low	1.917	306.720	31.60	400.00	PASS
Mid	1.650	264.000	31.60		PASS
High	1.633	261.280	31.60		PASS

DH 5

CH Low: $2.900 * (1600/6)/79 * 31.6 = 309.333$ (ms)

CH Mid: $2.900 * (1600/6)/79 * 31.6 = 309.333$ (ms)

CH High: $2.917 * (1600/6)/79 * 31.6 = 311.147$ (ms)

CH	Pulse Time (ms)	Total of Dwell (ms)	Period Time (s)	Limit (ms)	Result
Low	2.900	309.333	31.60	400.00	PASS
Mid	2.900	309.333	31.60		PASS
High	2.917	311.147	31.60		PASS



For 8DPSK

DH 1

CH Low

Agilent 16:11:56 Oct 8, 2010

R T

Δ Mkr1 383.3 μs
-0.31 dB

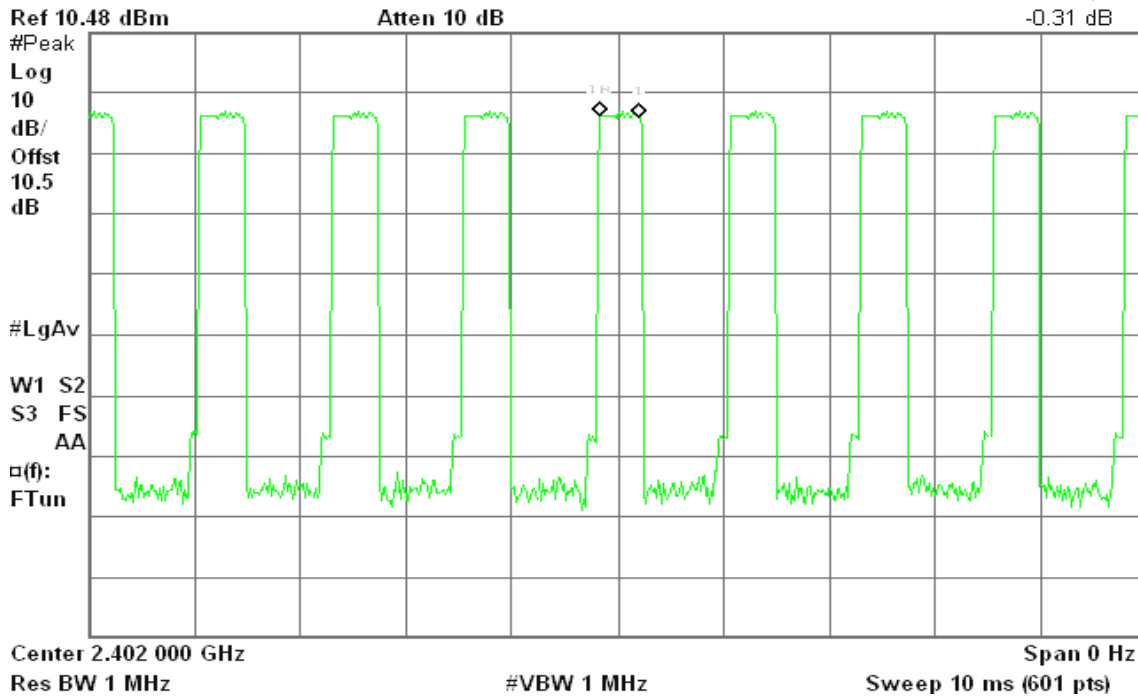

CH Mid

Agilent 16:13:18 Oct 8, 2010

R T

Δ Mkr1 400 μs
-0.22 dB

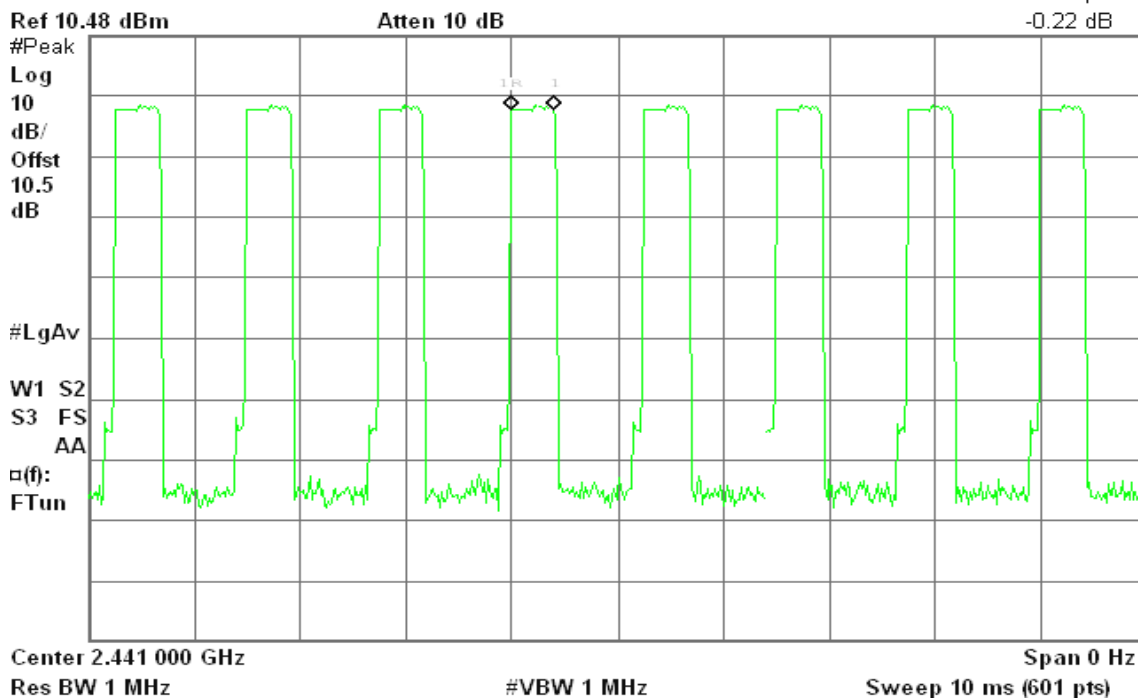



CH High

Agilent 16:19:37 Oct 8, 2010

R T

Δ Mkr1 400 μs
-0.32 dB

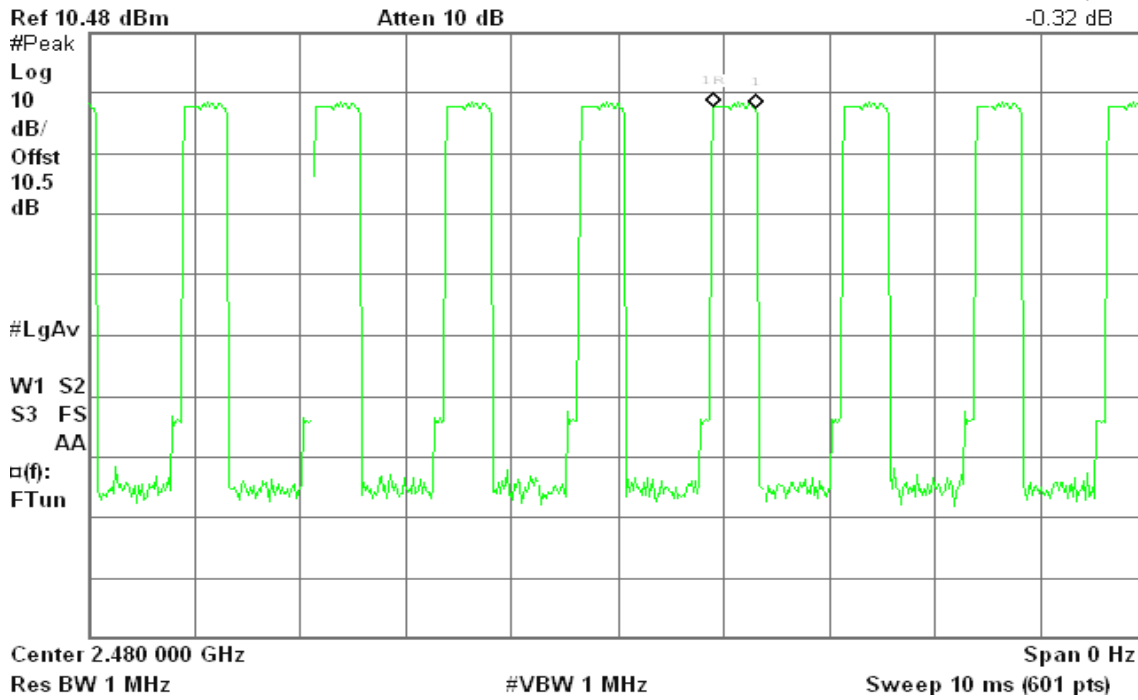

DH 3

CH Low

Agilent 16:10:49 Oct 8, 2010

R T

Δ Mkr1 1.917 ms
0.09 dB

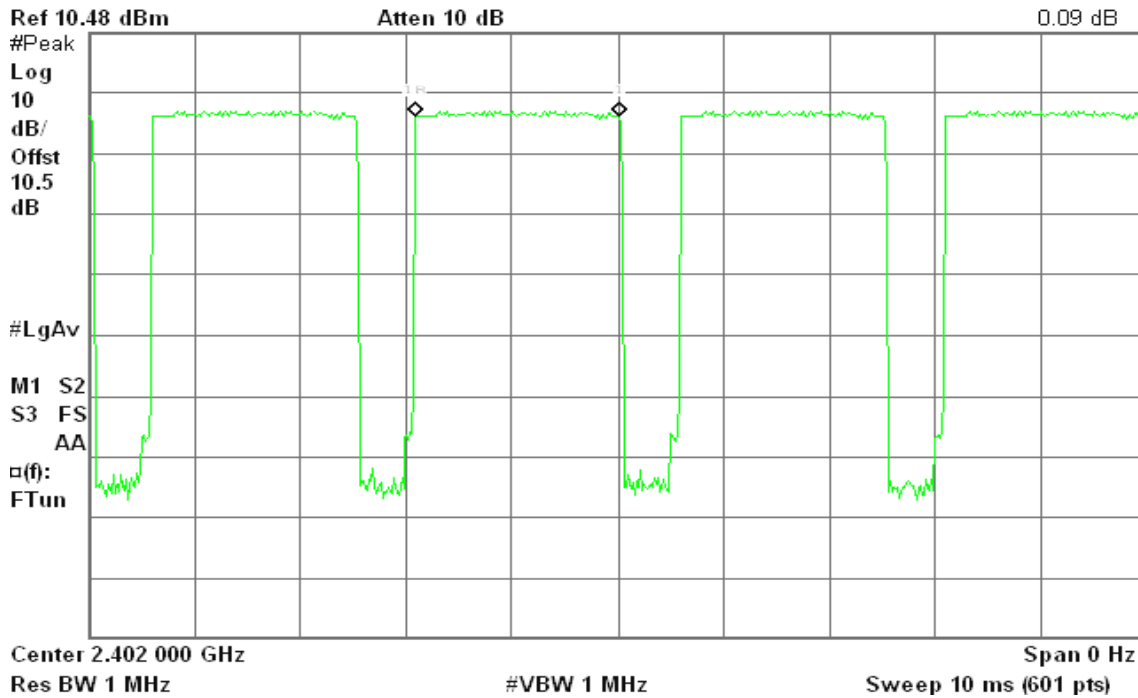



CH Mid

Agilent 16:14:29 Oct 8, 2010

R T

Δ Mkr1 1.65 ms
0.12 dB

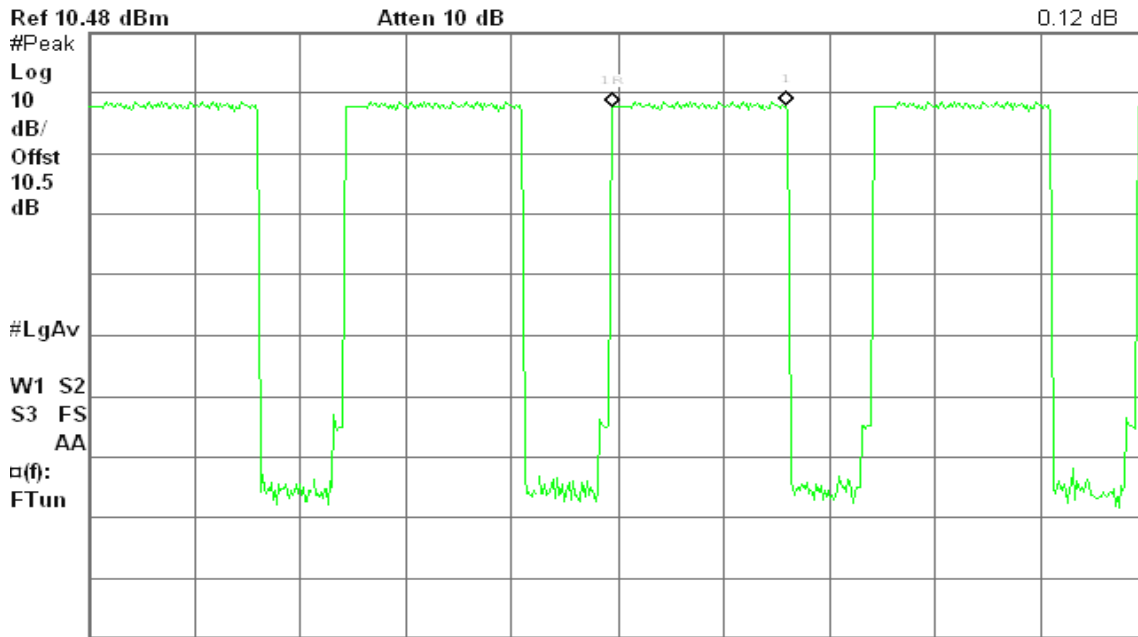

Center 2.441 000 GHz

Res BW 1 MHz

#VBW 1 MHz

Span 0 Hz

Sweep 10 ms (601 pts)

CH High

Agilent 16:18:40 Oct 8, 2010

R T

Δ Mkr1 1.633 ms
0.13 dB

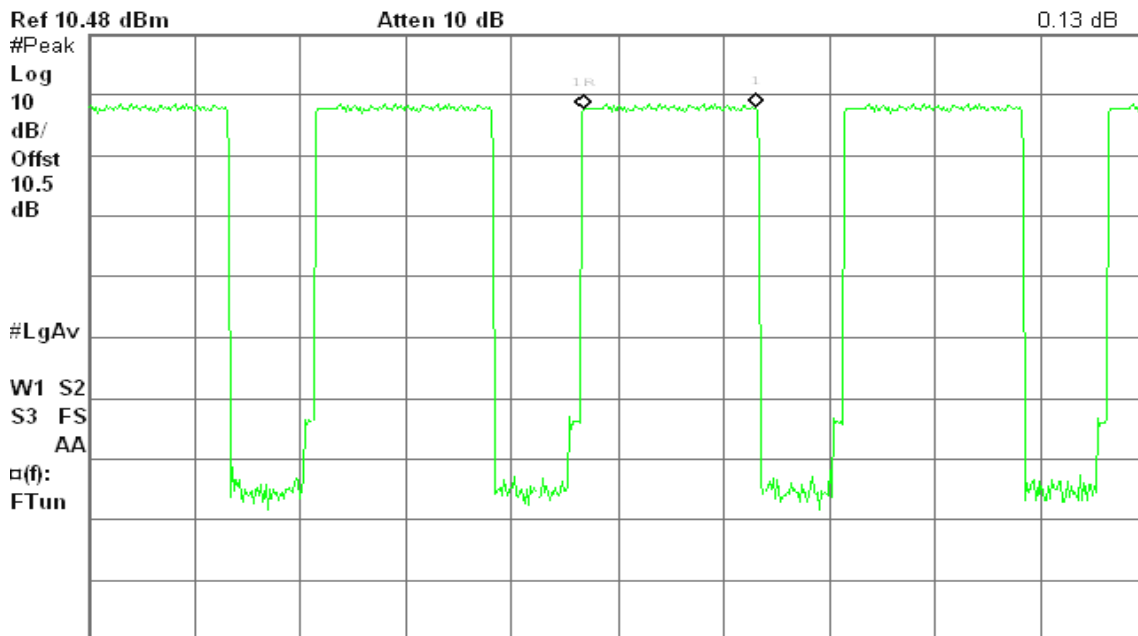

Center 2.480 000 GHz

Res BW 1 MHz

#VBW 1 MHz

Span 0 Hz

Sweep 10 ms (601 pts)



DH 5

CH Low

Agilent 15:56:34 Oct 8, 2010

R T

Δ Mkr1 2.9 ms
0.04 dB

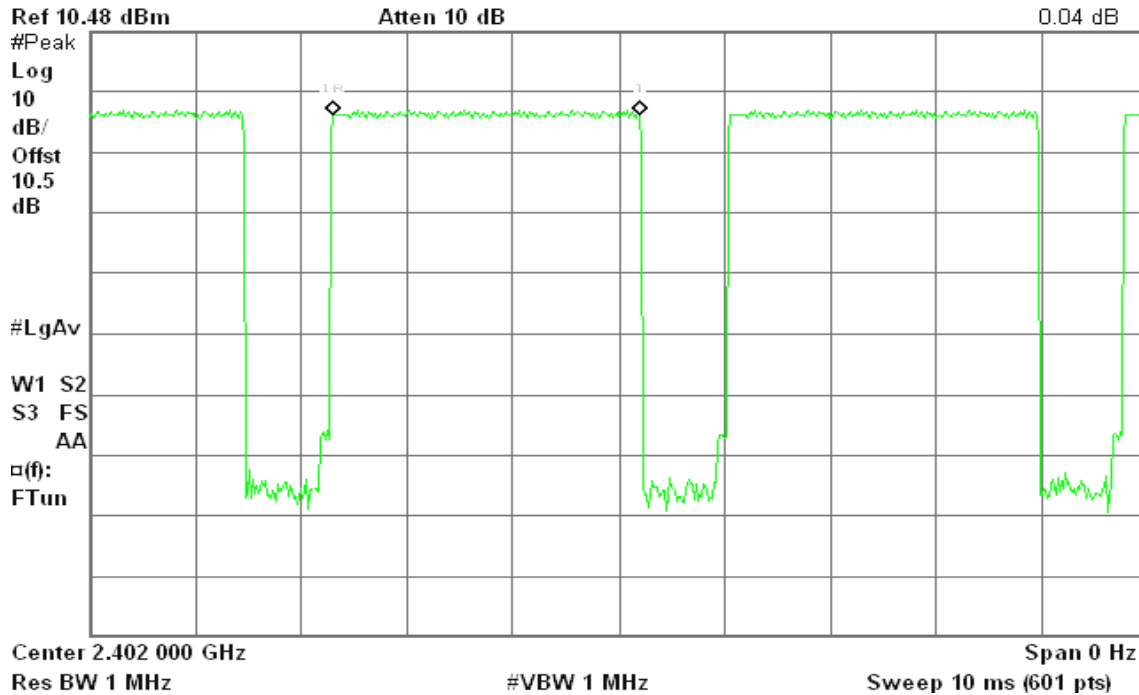

CH Mid

Agilent 16:15:08 Oct 8, 2010

R T

Δ Mkr1 2.9 ms
0.17 dB

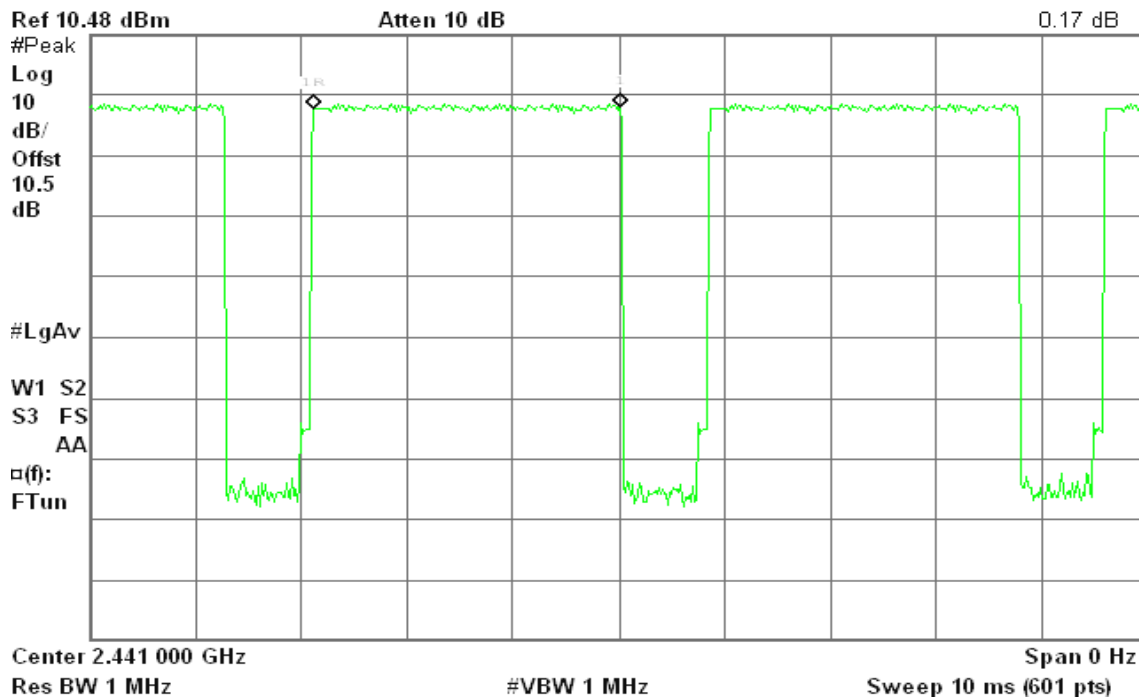



CH High

Agilent 16:17:59 Oct 8, 2010

R T

Δ Mkr1 2.917 ms
-0.07 dB

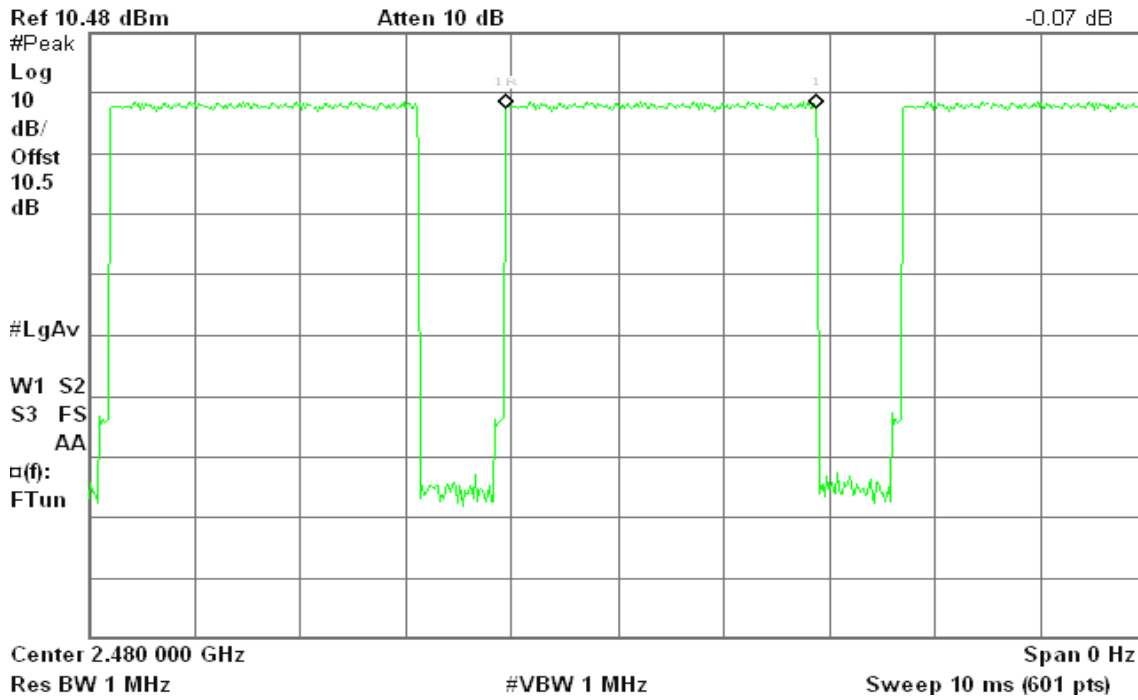



7.9 SPURIOUS EMISSIONS

7.9.1 Conducted Measurement

LIMIT

According to §15.247(d), in any 100 kHz bandwidth outside the frequency bands in which the spread spectrum intentional radiator is operating, the radio frequency power that is produced by the intentional radiator shall be at least 20 dB below that in the 100 kHz bandwidth within the band that contains the highest level of the desired power, based on either an RF conducted or a radiated measurement, provided the transmitter demonstrates compliance with the peak conducted power limits. In addition, radiated emissions which fall in the restricted bands, as defined in §15.205(a), must also comply with the radiated emission limits specified in 15.209(a) (see Section 15.205(c)).

Test Configuration

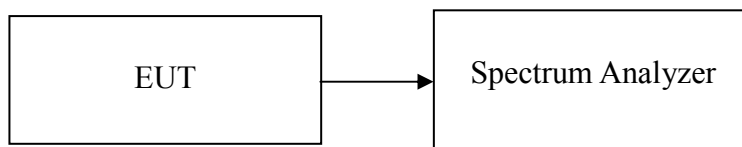

TEST PROCEDURE

Conducted RF measurements of the transmitter output were made to confirm that the EUT antenna port conducted emissions meet the specified limit and to identify any spurious signals that require further investigation or measurements on the radiated emissions site.

The transmitter output is connected to the spectrum analyzer. The resolution bandwidth is set to 100 kHz. The video bandwidth is set to 100 kHz.

Measurements are made over the 30MHz to 26GHz range with the transmitter set to the lowest, middle, and highest channels.

TEST RESULTS

No non-compliance noted



Test Plot

For GFSK / DH5

CH Low

Agilent 15:40:50 Oct 8, 2010

R T

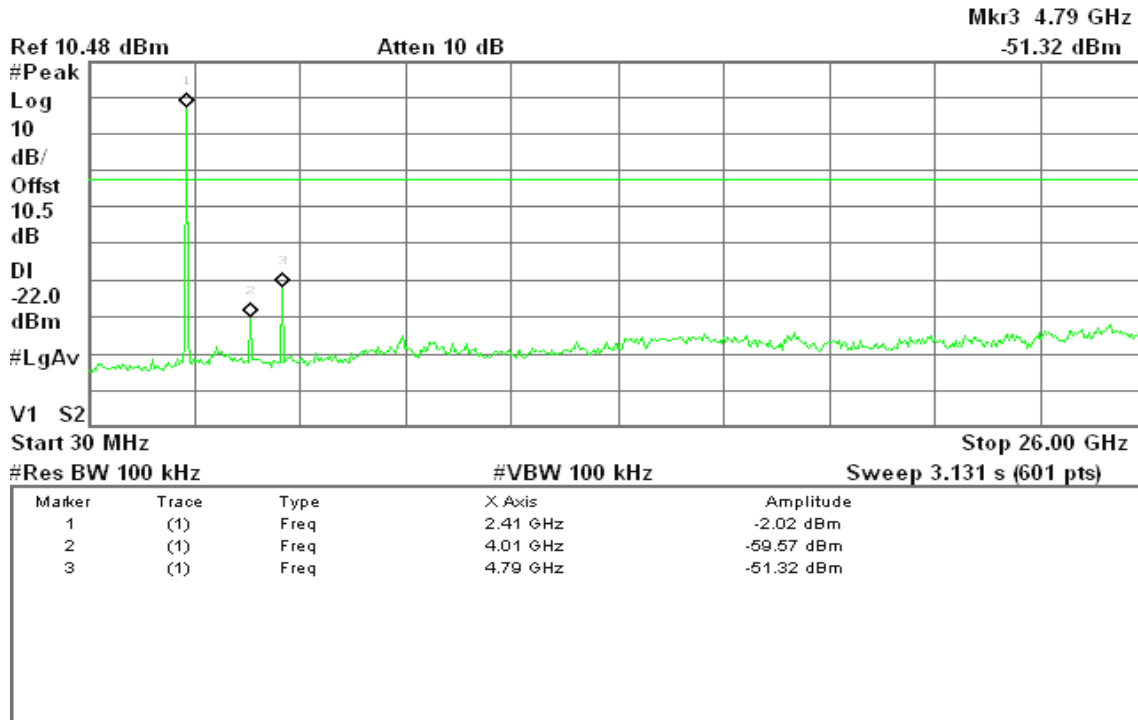

CH Mid

Agilent 15:41:33 Oct 8, 2010

R T

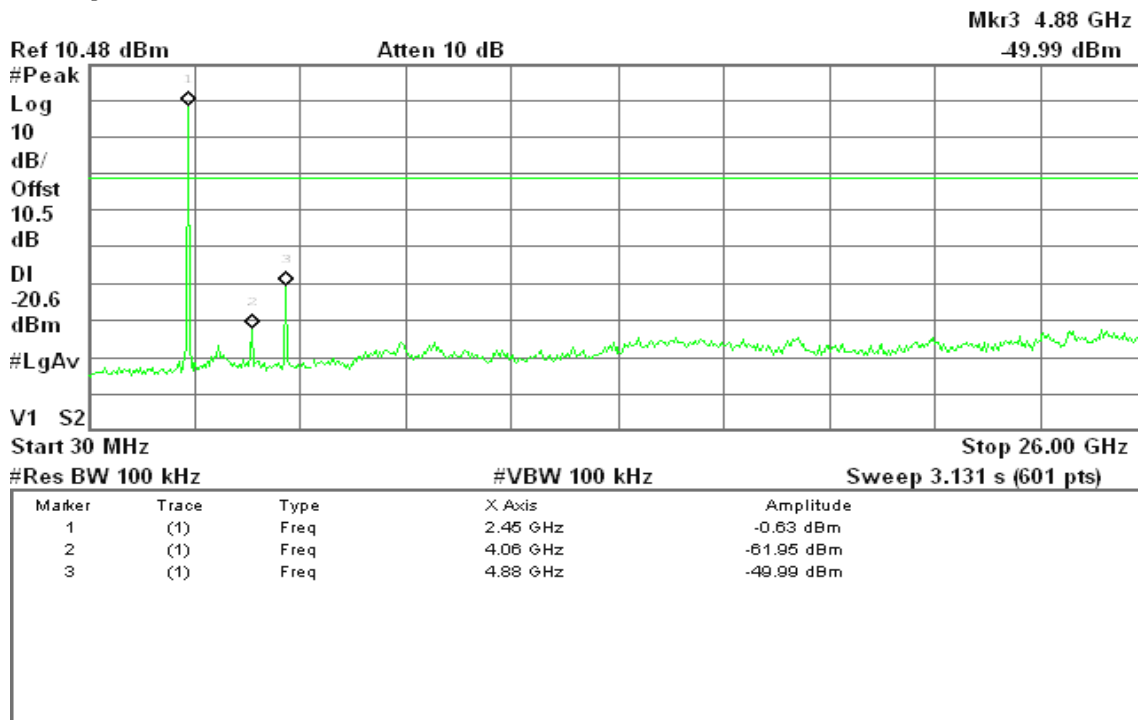



CH High

Agilent 15:42:43 Oct 8, 2010

R T

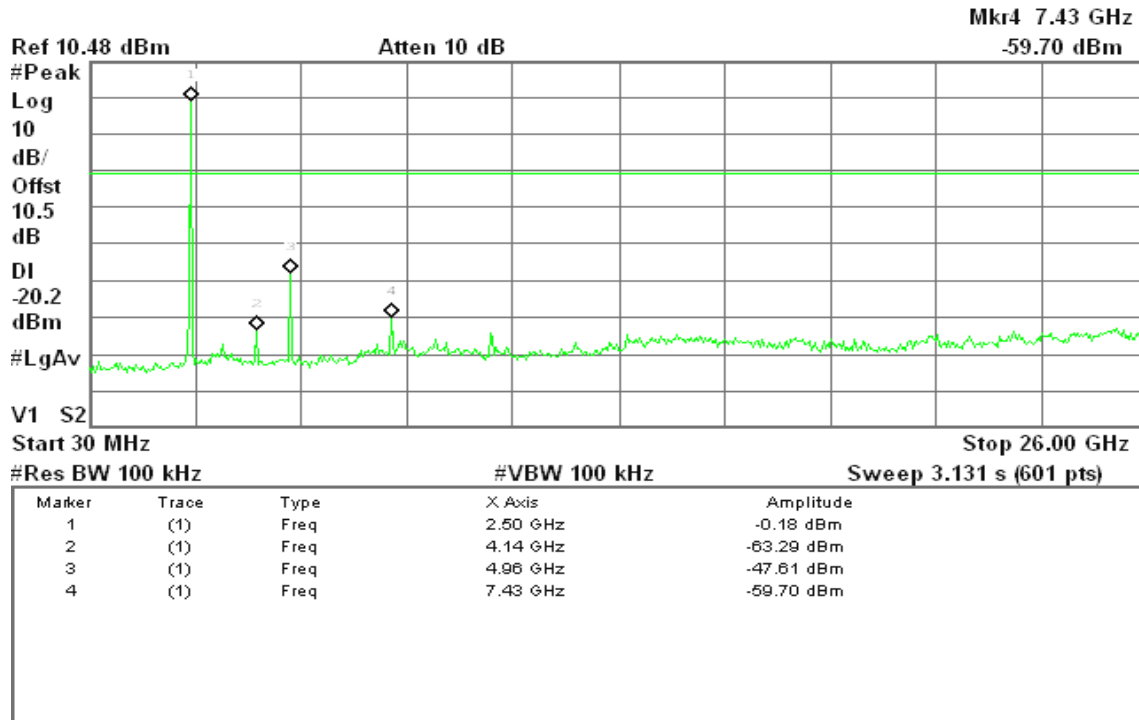



For 8DPSK / DH5

CH Low

Agilent 16:36:38 Oct 8, 2010

R T

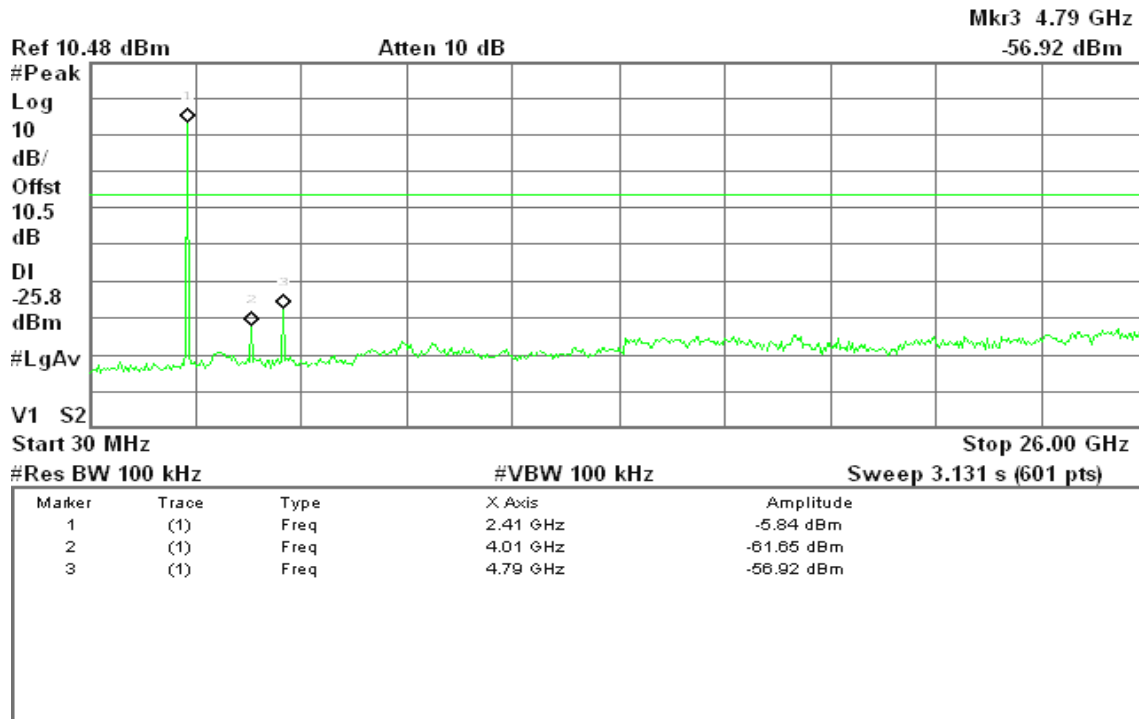

CH Mid

Agilent 16:33:59 Oct 8, 2010

R T

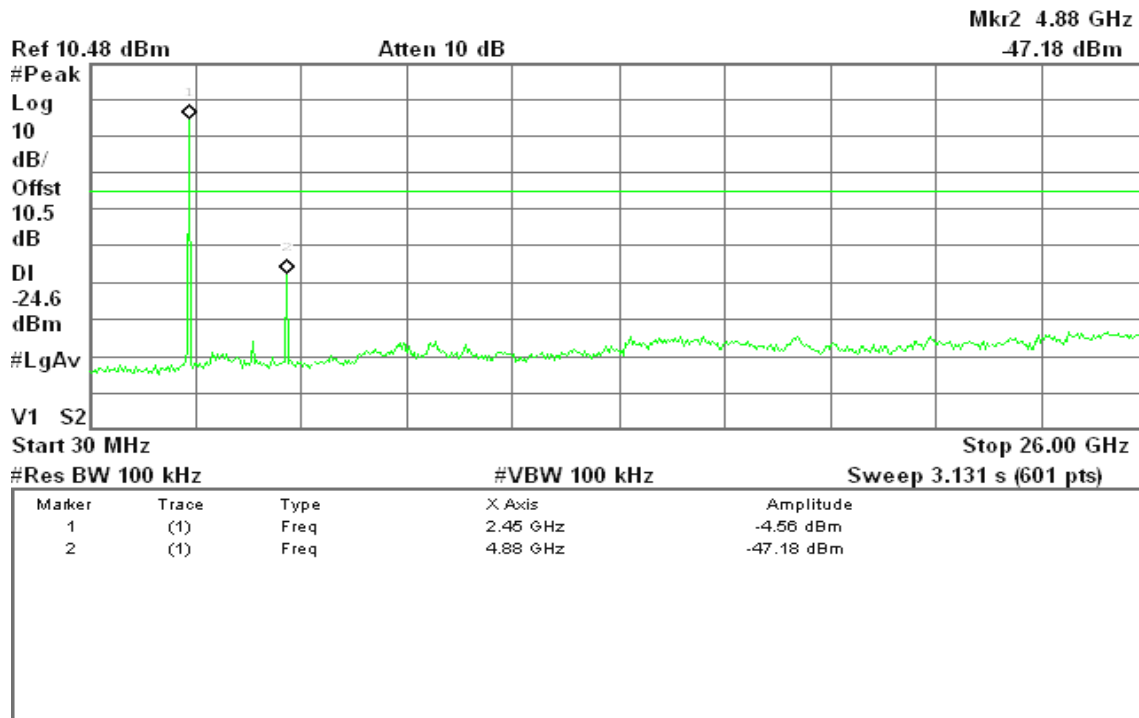



CH High

Agilent 16:32:06 Oct 8, 2010

R T

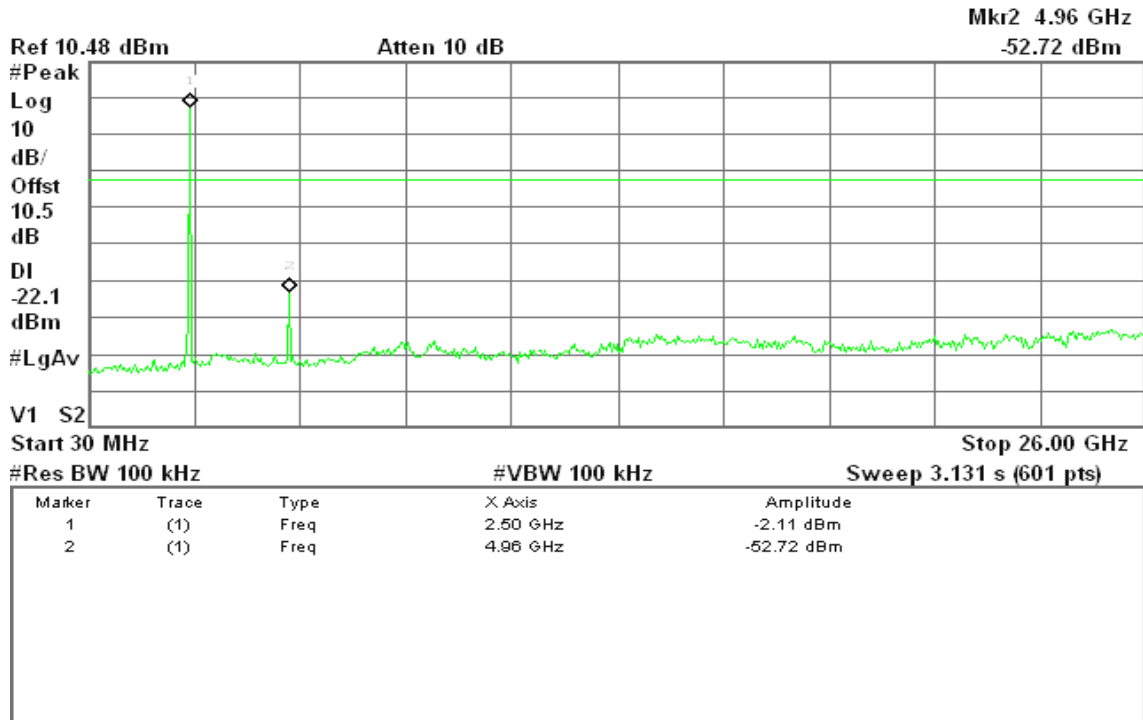



7.9.2 Radiated Emissions

LIMIT

1. According to §15.209(a), except as provided elsewhere in this Subpart, the emissions from an intentional radiator shall not exceed the field strength levels specified in the following table:

Frequency (MHz)	Field Strength ($\mu\text{V}/\text{m}$)	Measurement Distance (m)
30-88	100*	3
88-216	150*	3
216-960	200*	3
Above 960	500	3

Remark: Except as provided in paragraph (g), fundamental emissions from intentional radiators operating under this Section shall not be located in the frequency bands 54-72 MHz, 76-88 MHz, 174-216 MHz or 470-806 MHz. However, operation within these frequency bands is permitted under other sections of this Part, e.g., Sections 15.231 and 15.241.

2. In the emission table above, the tighter limit applies at the band edges.

Frequency (MHz)	Field Strength ($\mu\text{V}/\text{m}$ at 3-meter)	Field Strength (dB $\mu\text{V}/\text{m}$ at 3-meter)
30-88	100	40
88-216	150	43.5
216-960	200	46
Above 960	500	54



Test Configuration

9kHz ~ 30MHz

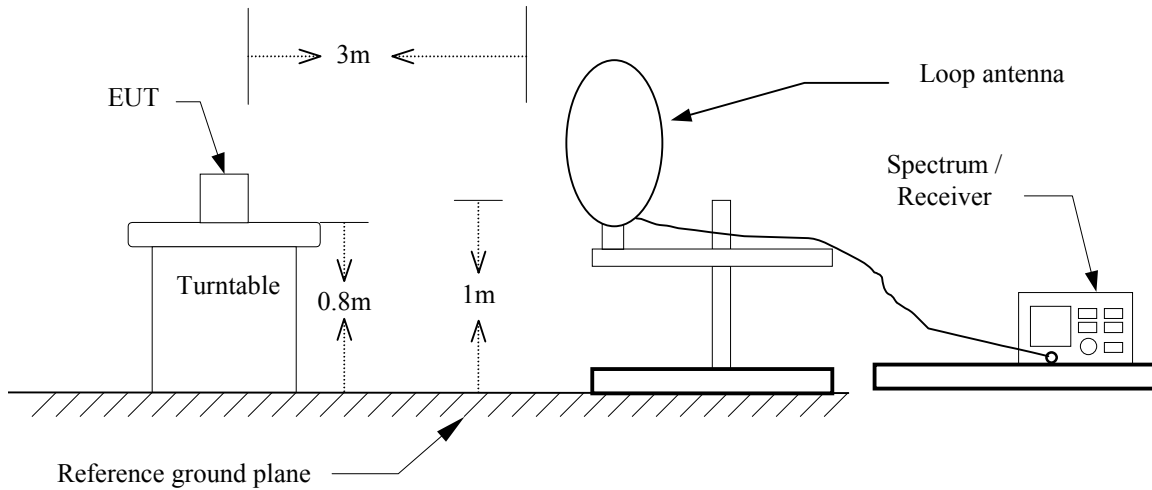

30MHz ~ 1GHz

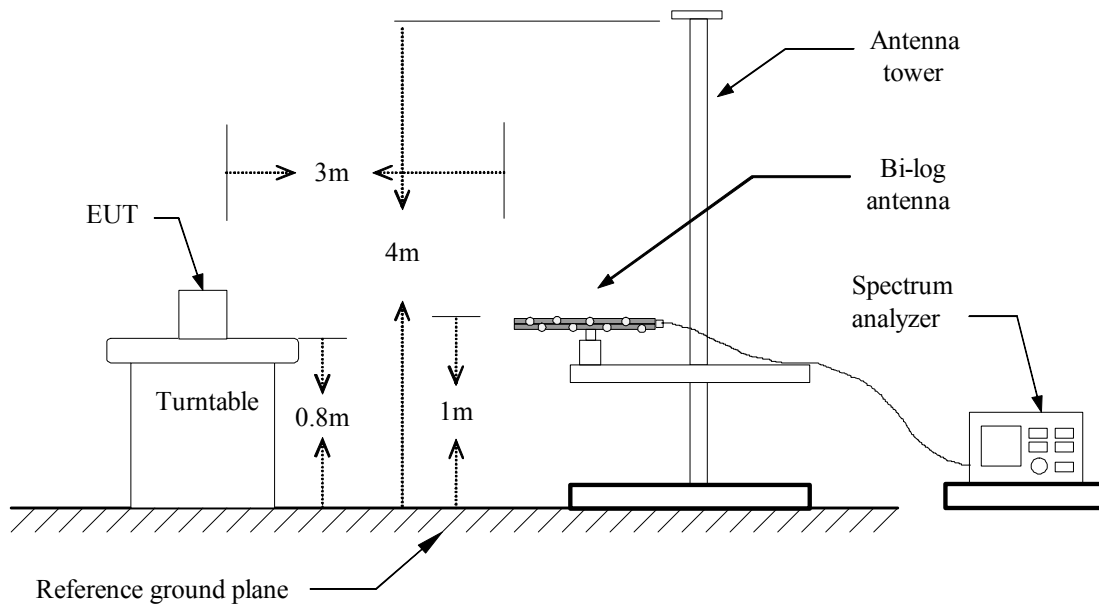



Above 1 GHz

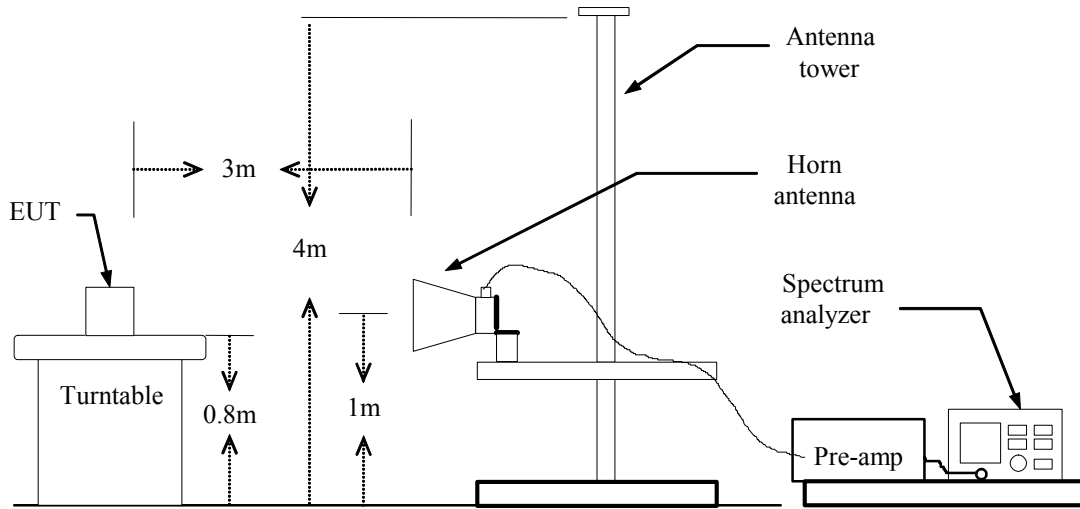



TEST PROCEDURE

1. The EUT is placed on a turntable, which is 0.8m above ground plane.
2. The turntable shall be rotated for 360 degrees to determine the position of maximum emission level.
3. EUT is set 3m away from the receiving antenna, which is varied from 1m to 4m to find out the highest emissions.
4. Maximum procedure was performed on the six highest emissions to ensure EUT compliance.
5. And also, each emission was to be maximized by changing the polarization of receiving antenna both horizontal and vertical.
6. Set the spectrum analyzer in the following setting as:
Below 1GHz:
RBW=100kHz / VBW=300kHz / Sweep=AUTO
Above 1GHz:
(a) PEAK: RBW=VBW=1MHz / Sweep=AUTO
(b) AVERAGE: RBW=1MHz / VBW=10Hz / Sweep=AUTO
7. Repeat above procedures until the measurements for all frequencies are complete.



Below 1 GHz

Operation Mode: Normal Link

Test Date: October 8, 2010

Temperature: 24°C

Tested by: Tom Jen

Humidity: 50 % RH

Polarity: Ver. / Hor.

Frequency (MHz)	Reading (dBuV)	Correction Factor (dB/m)	Result (dBuV/m)	Limit (dBuV/m)	Margin (dB)	Remark	Ant.Pol. (H/V)
72.03	51.41	-14.70	36.71	40.00	-3.29	Peak	V
117.30	50.85	-10.03	40.82	43.50	-2.68	Peak	V
159.33	37.55	-10.53	27.02	43.50	-16.48	QP	V
256.33	48.94	-10.48	38.46	46.00	-7.54	Peak	V
384.05	44.01	-7.40	36.61	46.00	-9.39	Peak	V
801.15	32.64	-1.33	31.31	46.00	-14.69	Peak	V
117.30	40.54	-10.03	30.51	43.50	-12.99	QP	H
149.63	50.45	-10.21	40.24	43.50	-3.26	QP	H
159.33	46.78	-10.53	36.25	43.50	-7.25	QP	H
256.33	42.19	-10.48	31.71	46.00	-14.29	QP	H
324.23	53.28	-8.66	44.61	46.00	-1.39	Peak	H
384.05	46.37	-7.40	38.98	46.00	-7.02	Peak	H

Remark:

1. No emission found between lowest internal used/generated frequency to 30MHz (9kHz~30MHz).
2. Radiated emissions measured were made with an instrument using peak/quasi-peak detector mode.
3. Quasi-peak test would be performed if the peak result were greater than the quasi-peak limit or as required by the applicant.
4. Measurements above show only up to 6 maximum emissions noted, or would be lesser, with " N/A " remark, if no specific emissions from the EUT are recorded (ie: margin>20dB from the applicable limit) and considered that's already beyond the background noise floor.
5. Margin (dB) = Remark result (dBuV/m) – Quasi-peak limit (dBuV/m).



Above 1 GHz

Operation Mode: TX / GFSK / DH5 / CH Low

Test Date: October 7, 2010

Temperature: 24°C

Tested by: Tom Jen

Humidity: 50 % RH

Polarity: Ver. / Hor.

Frequency (MHz)	Reading (Peak) (dBuV)	Reading (Average) (dBuV)	Correction Factor (dB/m)	Result (Peak) (dBuV/m)	Result (Average) (dBuV/m)	Limit (Peak) (dBuV/m)	Limit (Average) (dBuV/m)	Margin (dB)	Remark	Ant.Pol. (H/V)
1273.33	59.29	---	-9.14	50.16	---	74.00	54.00	-3.84	Peak	V
4800.00	53.54	47.06	1.18	54.72	48.24	74.00	54.00	-5.76	AVG	V
N/A										
1603.33	60.89	58.26	-7.81	53.08	50.45	74.00	54.00	-3.55	AVG	H
4800.00	56.51	51.30	1.18	57.70	52.48	74.00	54.00	-1.52	AVG	H
N/A										

Remark:

1. Measuring frequencies from 1 GHz to the 10th harmonic of highest fundamental frequency.
2. Radiated emissions measured in frequency above 1000MHz were made with an instrument using peak/average detector mode.
3. Average test would be performed if the peak result were greater than the average limit.
4. Data of measurement within this frequency range shown “ --- ” in the table above means the reading of emissions are attenuated more than 20dB below the permissible limits or the field strength is too small to be measured.
5. Measurements above show only up to 6 maximum emissions noted, or would be lesser; with “ N/A ” remark, if no specific emissions from the EUT are recorded (ie: margin > 20dB from the applicable limit) and considered that's already beyond the background noise floor.
6. Margin (dB) = Remark result (dBuV/m) – Average limit (dBuV/m).



Operation Mode: TX / GFSK / DH5 / CH Mid

Test Date: October 7, 2010

Temperature: 24°C

Tested by: Tom Jen

Humidity: 50 % RH

Polarity: Ver. / Hor.

Frequency (MHz)	Reading (Peak) (dBuV)	Reading (Average) (dBuV)	Correction Factor (dB/m)	Result (Peak) (dBuV/m)	Result (Average) (dBuV/m)	Limit (Peak) (dBuV/m)	Limit (Average) (dBuV/m)	Margin (dB)	Remark	Ant.Pol. (H/V)
1100.00	58.86	---	-9.42	49.43	---	74.00	54.00	-4.57	Peak	V
1330.00	58.67	---	-9.04	49.63	---	74.00	54.00	-4.37	Peak	V
1626.67	58.63	---	-7.59	51.04	---	74.00	54.00	-2.96	Peak	V
4883.33	51.51	43.83	1.16	52.67	44.99	74.00	54.00	-9.01	AVG	V
N/A										
1626.67	60.34	56.20	-7.59	52.75	48.61	74.00	54.00	-5.39	AVG	H
4883.33	51.88	46.67	1.16	53.04	47.83	74.00	54.00	-6.17	AVG	H
N/A										

Remark:

1. Measuring frequencies from 1 GHz to the 10th harmonic of highest fundamental frequency.
2. Radiated emissions measured in frequency above 1000MHz were made with an instrument using peak/average detector mode.
3. Average test would be performed if the peak result were greater than the average limit.
4. Data of measurement within this frequency range shown " --- " in the table above means the reading of emissions are attenuated more than 20dB below the permissible limits or the field strength is too small to be measured.
5. Measurements above show only up to 6 maximum emissions noted, or would be lesser, with " N/A " remark, if no specific emissions from the EUT are recorded (ie: margin > 20dB from the applicable limit) and considered that's already beyond the background noise floor.
6. Margin (dB) = Remark result (dBuV/m) – Average limit (dBuV/m).



Operation Mode: TX / GFSK / DH5 / CH High

Test Date: October 7, 2010

Temperature: 24°C

Tested by: Tom Jen

Humidity: 50 % RH

Polarity: Ver. / Hor.

Frequency (MHz)	Reading (Peak) (dBuV)	Reading (Average) (dBuV)	Correction Factor (dB/m)	Result (Peak) (dBuV/m)	Result (Average) (dBuV/m)	Limit (Peak) (dBuV/m)	Limit (Average) (dBuV/m)	Margin (dB)	Remark	Ant.Pol. (H/V)
1066.67	60.69	---	-9.48	51.21	---	74.00	54.00	-2.79	Peak	V
4958.33	49.32	---	1.13	50.45	---	74.00	54.00	-3.55	Peak	V
N/A										
1653.33	58.16	---	-7.35	50.82	---	74.00	54.00	-3.18	Peak	H
N/A										

Remark:

1. Measuring frequencies from 1 GHz to the 10th harmonic of highest fundamental frequency.
2. Radiated emissions measured in frequency above 1000MHz were made with an instrument using peak/average detector mode.
3. Average test would be performed if the peak result were greater than the average limit.
4. Data of measurement within this frequency range shown " --- " in the table above means the reading of emissions are attenuated more than 20dB below the permissible limits or the field strength is too small to be measured.
5. Measurements above show only up to 6 maximum emissions noted, or would be lesser, with " N/A " remark, if no specific emissions from the EUT are recorded (ie: margin > 20dB from the applicable limit) and considered that's already beyond the background noise floor.
6. Margin (dB) = Remark result (dBuV/m) – Average limit (dBuV/m).



Operation Mode: TX / 8DPSK / DH5 / CH Low

Test Date: November 15, 2010

Temperature: 24°C

Tested by: Tom Jen

Humidity: 50 % RH

Polarity: Ver. / Hor.

Frequency (MHz)	Reading (Peak) (dBuV)	Reading (Average) (dBuV)	Correction Factor (dB/m)	Result (Peak) (dBuV/m)	Result (Average) (dBuV/m)	Limit (Peak) (dBuV/m)	Limit (Average) (dBuV/m)	Margin (dB)	Remark	Ant.Pol. (H/V)
1506.67	58.91	---	-8.70	50.21	---	74.00	54.00	-3.79	Peak	V
2743.33	57.18	42.96	-1.95	55.23	41.01	74.00	54.00	-12.99	AVG	V
N/A										
1080.00	58.85	---	-9.46	49.39	---	74.00	54.00	-4.61	Peak	H
1436.67	58.46	---	-8.87	49.59	---	74.00	54.00	-4.41	Peak	H
1763.33	58.06	44.42	-6.33	51.73	38.09	74.00	54.00	-15.91	AVG	H
1856.67	58.44	44.28	-5.47	52.97	38.81	74.00	54.00	-15.19	AVG	H
N/A										

Remark:

1. Measuring frequencies from 1 GHz to the 10th harmonic of highest fundamental frequency.
2. Radiated emissions measured in frequency above 1000MHz were made with an instrument using peak/average detector mode.
3. Average test would be performed if the peak result were greater than the average limit.
4. Data of measurement within this frequency range shown " --- " in the table above means the reading of emissions are attenuated more than 20dB below the permissible limits or the field strength is too small to be measured.
5. Measurements above show only up to 6 maximum emissions noted, or would be lesser, with " N/A " remark, if no specific emissions from the EUT are recorded (ie: margin > 20dB from the applicable limit) and considered that's already beyond the background noise floor.
6. Margin (dB) = Remark result (dBuV/m) – Average limit (dBuV/m).



Operation Mode: TX / 8DPSK / DH5 / CH Mid

Test Date: November 15, 2010

Temperature: 24°C

Tested by: Tom Jen

Humidity: 50 % RH

Polarity: Ver. / Hor.

Frequency (MHz)	Reading (Peak) (dBuV)	Reading (Average) (dBuV)	Correction Factor (dB/m)	Result (Peak) (dBuV/m)	Result (Average) (dBuV/m)	Limit (Peak) (dBuV/m)	Limit (Average) (dBuV/m)	Margin (dB)	Remark	Ant.Pol. (H/V)
2083.33	57.87	43.79	-3.90	53.97	39.89	74.00	54.00	-14.11	AVG	V
4883.33	55.60	41.80	1.16	56.76	42.96	74.00	54.00	-11.04	AVG	V
N/A										
1120.00	58.68	---	-9.39	49.29	---	74.00	54.00	-4.71	Peak	H
N/A										

Remark:

1. Measuring frequencies from 1 GHz to the 10th harmonic of highest fundamental frequency.
2. Radiated emissions measured in frequency above 1000MHz were made with an instrument using peak/average detector mode.
3. Average test would be performed if the peak result were greater than the average limit.
4. Data of measurement within this frequency range shown " --- " in the table above means the reading of emissions are attenuated more than 20dB below the permissible limits or the field strength is too small to be measured.
5. Measurements above show only up to 6 maximum emissions noted, or would be lesser, with " N/A " remark, if no specific emissions from the EUT are recorded (ie: margin > 20dB from the applicable limit) and considered that's already beyond the background noise floor.
6. Margin (dB) = Remark result (dBuV/m) – Average limit (dBuV/m).



Operation Mode: TX / 8DPSK / DH5 / CH High

Test Date: November 15, 2010

Temperature: 24°C

Tested by: Tom Jen

Humidity: 50 % RH

Polarity: Ver. / Hor.

Frequency (MHz)	Reading (Average) (dBuV)	Correction Factor (dB/m)	Result (Peak) (dBuV/m)	Result (Average) (dBuV/m)	Limit (Peak) (dBuV/m)	Limit (Average) (dBuV/m)	Margin (dB)	Remark	Ant.Pol. (H/V)	Reading (Peak) (dBuV)
1430.00	58.58	---	-8.88	49.71	---	74.00	54.00	-4.29	Peak	V
4958.33	50.51	---	1.13	51.64	---	74.00	54.00	-2.36	Peak	V
N/A										
1326.67	58.55	---	-9.05	49.50	---	74.00	54.00	-4.50	Peak	H
4958.33	47.56	---	1.13	48.69	---	74.00	54.00	-5.31	Peak	H
N/A										

Remark:

1. Measuring frequencies from 1 GHz to the 10th harmonic of highest fundamental frequency.
2. Radiated emissions measured in frequency above 1000MHz were made with an instrument using peak/average detector mode.
3. Average test would be performed if the peak result were greater than the average limit`.
4. Data of measurement within this frequency range shown “ --- ” in the table above means the reading of emissions are attenuated more than 20dB below the permissible limits or the field strength is too small to be measured.
5. Measurements above show only up to 6 maximum emissions noted, or would be lesser; with “ N/A ” remark, if no specific emissions from the EUT are recorded (ie: margin>20dB from the applicable limit) and considered that's already beyond the background noise floor.
6. Margin (dB) = Remark result (dBuV/m) – Average limit (dBuV/m).



7.10 POWERLINE CONDUCTED EMISSIONS

LIMIT

According to §15.207(a), except as shown in paragraphs (b) and (c) of this section, for an intentional radiator that is designed to be connected to the public utility (AC) power line, the radio frequency voltage that is conducted back onto the AC power line on any frequency or frequencies within the band 150 kHz to 30 MHz shall not exceed the limits in the following table, as measured using a 50 μ H/50 ohms line impedance stabilization network (LISN). Compliance with the provisions of this paragraph shall be based on the measurement of the radio frequency voltage between each power line and ground at the power terminal. The lower limit applies at the boundary between the frequency ranges.

Frequency Range (MHz)	Limits (dB μ V)	
	Quasi-peak	Average
0.15 to 0.50	66 to 56*	56 to 46*
0.50 to 5	56	46
5 to 30	60	50

* Decreases with the logarithm of the frequency.

Test Configuration

See test photographs attached in Appendix II for the actual connections between EUT and support equipment.

TEST PROCEDURE

1. The EUT was placed on a table, which is 0.8m above ground plane.
2. Maximum procedure was performed on the six highest emissions to ensure EUT compliance.
3. Repeat above procedures until all frequency measured were complete.



TEST RESULTS

The initial step in collecting conducted data is a spectrum analyzer peak scan of the measurement range. Significant peaks are then marked as shown on the following data page, and these signals are then quasi-peaked.

Test Data

Operation Mode: Normal Link

Test Date: September 8, 2010

Temperature: 22°C

Tested by: Tom Jen

Humidity: 45% RH

Freq. (MHz)	QP Reading (dBuV)	AV Reading (dBuV)	Corr. factor (dB)	QP Result (dBuV)	AV Result (dBuV)	QP Limit (dBuV)	AV Limit (dBuV)	QP Margin (dB)	AV Margin (dB)	Note
0.2100	45.82	37.02	0.18	46.00	37.20	63.21	53.21	-17.21	-16.01	L1
0.2800	33.35	23.75	0.15	33.50	23.90	60.82	50.82	-27.32	-26.92	L1
2.7000	23.13	12.63	0.07	23.20	12.70	56.00	46.00	-32.80	-33.30	L1
15.7250	37.93	32.23	0.77	38.70	33.00	60.00	50.00	-21.30	-17.00	L1
23.8300	34.92	33.52	0.88	35.80	34.40	60.00	50.00	-24.20	-15.60	L1
26.8100	38.97	38.57	0.93	39.90	39.50	60.00	50.00	-20.10	-10.50	L1
0.1500	46.86	36.16	0.24	47.10	36.40	66.00	56.00	-18.90	-19.60	L2
0.2100	45.70	36.90	0.20	45.90	37.10	63.21	53.21	-17.31	-16.11	L2
0.2850	33.53	26.43	0.17	33.70	26.60	60.67	50.67	-26.97	-24.07	L2
2.7000	26.89	19.79	0.11	27.00	19.90	56.00	46.00	-29.00	-26.10	L2
15.7250	36.89	31.19	0.81	37.70	32.00	60.00	50.00	-22.30	-18.00	L2
26.8100	37.69	37.49	1.01	38.70	38.50	60.00	50.00	-21.30	-11.50	L2

Remark:

1. Measuring frequencies from 0.15 MHz to 30MHz.
2. The emissions measured in frequency range from 0.15 MHz to 30MHz were made with an instrument using Quasi-peak detector and average detector.
3. The IF bandwidth of SPA between 0.15MHz and 30MHz was 10kHz; the IF bandwidth of Test Receiver between 0.15MHz and 30MHz was 9kHz;
4. L1 = Line One (Live Line) / L2 = Line Two (Neutral Line)



Test Plots

Conducted emissions (Line 1)

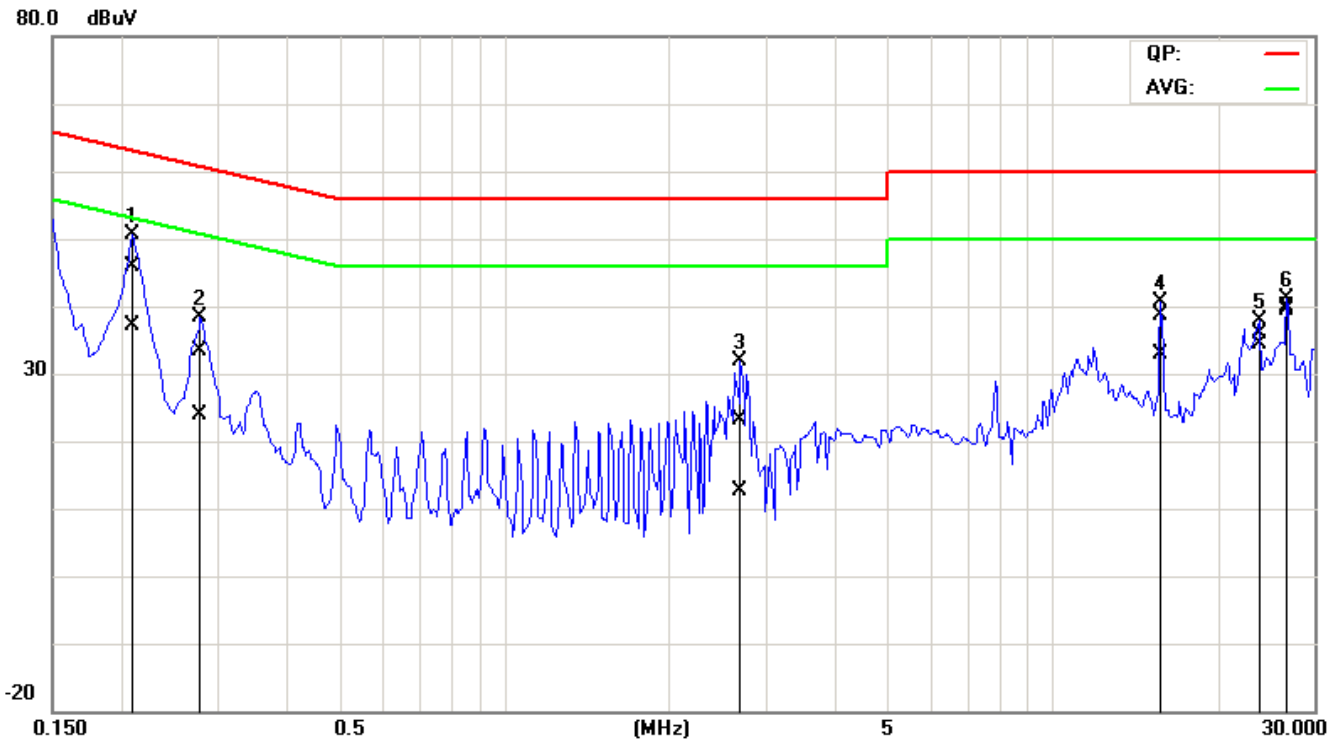

Conducted emissions (Line 2)

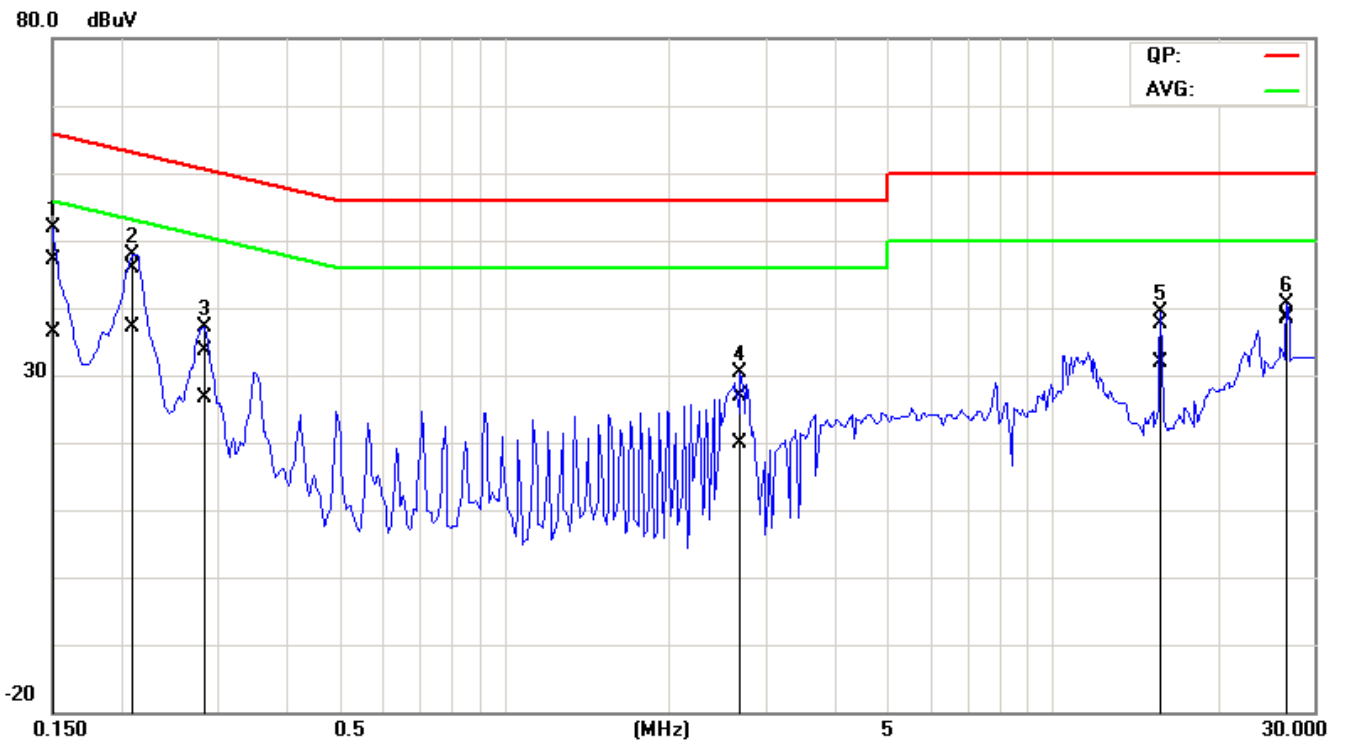



APPENDIX I RADIO FREQUENCY EXPOSURE

LIMIT

According to §15.247(i), systems operating under the provisions of this section shall be operated in a manner that ensures that the public is not exposed to radio frequency energy levels in excess of the Commission's guidelines. See § 1.1307(b)(1) of this chapter.

EUT Specification

EUT	Bluetooth Audio Transmitter
Frequency band (Operating)	<input type="checkbox"/> WLAN: 2.412GHz ~ 2.462GHz <input type="checkbox"/> WLAN: 5.18GHz ~ 5.32GHz / 5.50GHz ~ 5.70GHz <input type="checkbox"/> WLAN: 5.745GHz ~ 5.825GHz <input checked="" type="checkbox"/> Others: <u>Bluetooth: 2.402GHz ~ 2.480GHz</u>
Device category	<input checked="" type="checkbox"/> Portable (<20cm separation) <input type="checkbox"/> Mobile (>20cm separation) <input type="checkbox"/> Others _____
Exposure classification	<input type="checkbox"/> Occupational/Controlled exposure ($S = 5mW/cm^2$) <input checked="" type="checkbox"/> General Population/Uncontrolled exposure ($S = 1mW/cm^2$)
Antenna diversity	<input checked="" type="checkbox"/> Single antenna <input type="checkbox"/> Multiple antennas <input type="checkbox"/> Tx diversity <input type="checkbox"/> Rx diversity <input type="checkbox"/> Tx/Rx diversity
Max. output power	0.68 dBm (1.169mW)
Antenna gain (Max)	-2.9 dBi (Numeric gain: 0.51)
Evaluation applied	<input type="checkbox"/> MPE Evaluation <input type="checkbox"/> SAR Evaluation <input checked="" type="checkbox"/> N/A*

Remark:

1. The maximum output power is 0.68 dBm (1.169 mW) at 2480MHz (with 0.51 numeric antenna gain.)
2. DTS device is not subject to routine RF evaluation; MPE estimate is used to justify the compliance.
3. For mobile or fixed location transmitters, no SAR consideration applied. The maximum power density is 1.0 mW/cm² even if the calculation indicates that the power density would be larger.

TEST RESULTS

No non-compliance noted.

(SAR evaluation is not required for the PORTABLE device while its maximum output power is lower than the general population low threshold: $60/f_{(GHz)} = 60/2.441 = 24.58mW$)