

TEST REPORT

Test Report No.: 10008FC

Applicant : Clarion Co., Ltd.
 EUT : Bluetooth Module
 Model No. : BTU-3586
 Serial No. : 47 (Radiated Emission Test)
 9 (Conducted RF Test via Antenna Terminal)
 FCC ID : SJ2QY7200
 Issue Date : 27 May 2010
 Date of Test : 13, 14, 17 May 2010 (Radiated Emission Test)
 19 May 2010 (Conducted RF Test via Antenna Terminal)
 Standard : FCC Part 15 Subpart C
 ANSI C63.4: 2003
 PUBLIC NOTICE DA 00-705
 PUBLIC NOTICE DA 00-1407
 Test Results : Pass

Approved By:

 2010.5.27
 Manager / Jiro Ogiwara

Reviewed By:

 2010.5.27
 / Yukihiro Minegishi

 2010.5.27
 / Kentaro Fukuda

Tested By:

 2010.5.27
 / Yukihiro Minegishi

 2010.5.27
 / Masashi Tsukui

NVLAP[®]

NVLAP LAB CODE 200607-0

Table of Contents

Revised Record	4
1 Notice.....	5
1.1 General Information	5
1.2 Test Report	5
1.3 Test Condition	5
2 Applicant Information	6
2.1 Customer Information.....	6
2.2 Product Description.....	6
2.3 Summary of Test and Inspection Result.....	7
3 System Test Configuration	8
3.1 Justification	8
3.2 Operating Modes	9
3.3 Configuration of Tested System.....	10
3.4 Test Instruments	11
4 Antenna Requirement.....	12
5 AC Powerline Conducted Emission.....	13
6 20dB Bandwidth	14
6.1 Test Setup	14
6.2 Test Results	14
7 Carrier Frequency Separation	15
7.1 Test Setup	15
7.2 Test Results	15
8 Number of Hopping Frequency	17
8.1 Test Setup	17
8.2 Test Results	17
9 Dwell Time	18
9.1 Test Setup	18
9.2 Test Results	18
10 Maximum Peak Output Power	21
10.1 Test Setup	21
10.2 Test Results	21
11 Band Edge Compliance.....	22
11.1 Test Setup	22
11.2 Test Results	22
12 Spurious RF Conducted Emission	26
12.1 Test Setup	26
12.2 Test Results	26
13 Radiated Emission.....	36
13.1 Test Setup	36
13.2 Radiated Emission Calculation.....	36
13.3 Test Results	37
14 Photos of Tested EUT and Test Setup.....	46

Appendix 1: AFH-Hopping Sequence.....47
Appendix 2: Certificate of Accreditation49
Appendix 3: Test Instruments.....50

Revised Record

Revised Record					
Number of Revised Time	Mark	Issue Date	Person in Charge	Detail of Revision	Approved By
Initial	-	27 May 2010	Masashi Tsukui	-	Jiro Ogiwara

1 Notice

1.1 General Information

TAIYO YUDEN CO., LTD. EMC Center.
5607-2, Nakamuroda-machi, Takasaki-shi, Gunma, 370-3347, Japan.

1. This laboratory is accredited as an ISO/IEC 17025:2005 testing facility by NVLAP. (NVLAP LAB CODE: 200607-0). Refer the certificate of the accreditation to Appendix 1.
2. This laboratory is listed by the Federal Communications Commission, Equipment Authorization Division (Registration Number: 606514) and listed by Industry Canada (No.4389A-1).
3. We hereby certify that no party to the applications authorized hereunder is subject to a denial of benefits, including FCC benefits, pursuant to Section 5301 of the Anti-Drug Abuse Act of 1988, 21 U.S.C 853(a).

1.2 Test Report

1. This report must not be used by the client to claim product certification, approval or endorsement by NVLAP, NIST or any agency of the Federal Government.
2. The test results in this report relate only to the tested samples.
3. This report shall not be reproduced except in full, without the written approval of the TAIYO YUDEN CO., LTD. EMC Center.
4. The test results in this report are traceable to international standards.
5. The tests described in this report were conducted only within the accredited scope.

1.3 Test Condition

1. FCC 47CFR, Part 15 Subpart C regulation tests were performed in the shielded room and the 10m semi-anechoic chamber located at TAIYO YUDEN CO., LTD. EMC Center, 5607-2 Nakamuroda-machi, Takasaki-shi, Gunma, 370-3347 Japan.
2. The EUT was not modified for the tests described in this report.
3. The tests described in this report were conducted according to the methods in the test specification.
4. Special accessories or peripheral equipments specific to the EUT were not used for the tests described in this report.

2 Applicant Information

2.1 Customer Information

Company Name	Clarion Co., Ltd.
Address	7-2 Shintoshin, Chuo-ku, Saitama-shi, Saitama, 330-0081, Japan

2.2 Product Description

EUT	Bluetooth Module
Model No.	BTU-3586
Serial No.	47 (Radiated Emission Test) 9 (Conducted RF Test via Antenna Terminal)
FCC ID	SJ2QY7200
Production Stage	Pre-Production
Type of Wide Band Modulation	FHSS Frequency Hopping (79ch) AFH: Adaptive Frequency Hopping (20ch)
Type of Modulation	GFSK, $\pi/4$ -DQPSK and 8DPSK
ITU Code	F1D, G1D
Power Supply	DC 3.3V
Operating Voltage Range	DC 3.10V Min. DC 3.60V Max.
Operating Temperature Range	-40 degree C Min. 85 degree C Max.
Dimensions of EUT	W165.5mm * L80.5mm * H1.2mm
Antenna Type	Inverted F
Max Antenna Gain	1.60dBi
Operating Clocks	26MHz
Receipt Date of Tested Sample	12 May 2010

This EUT is Front PCB with Bluetooth module.

This is operated within the bands 2400 - 2483.5MHz frequency hopping intentional radiators.

It provides 79 channels. And it adopts an AFH function to prevent interference with other wireless applications. Refer to Appendix 1.

EUT operates in the unlicensed 2.4 GHz ISM (Industrial Scientific Medical) band. A frequency hop transceiver is applied to combat interference and fading.

2.3 Summary of Test and Inspection Result

No.	Item	Test Procedure	Specification	Remarks	Tested	Worst Margin	Results
1	AC Powerline Conducted Emission	ANSI C63.4: 2003	FCC 15.207	Conducted Emission Test	N/A	-	N/A*1
2	Carrier Frequency Separation	Public Notice DA00-705	FCC 15.247 (a)(1)	Conducted RF Test via Antenna Terminal	Performed	-	Pass
3	Number of Hopping Frequency	Public Notice DA00-1407	FCC 15.247 (a)(1)(iii)		Performed	-	Pass
4	Dwell Time		FCC 15.247 (a)(1)(iii)		Performed	-	Pass
5	Maximum Peak Output Power		FCC 15.247 (b)(1)		Performed	-	Pass
6	Band Edge Compliance		FCC 15.247(d)		Performed	-	Pass
7	Spurious RF Conducted Emission		FCC 15.247(d)		Performed	-	Pass
8	Radiated Emission		FCC 15.247(d)		Radiated Emission Test	Performed	Average: 2.1dB Transmitting Mode: 2402MHz Type of Modulation: GFSK Modulation Frequency: 4804.000MHz Antenna Polarization: Horizontal

*1: This EUT is intended for use in vehicles. So this measurement is not applied to this EUT.

3 System Test Configuration

3.1 Justification

1. Emission tests were performed with no deviation from the ANSI C63.4: 2003 and FCC 47CFR, Part 15 Section 15.247 regulation tests were performed with no deviation from the FCC Public Notice DA00-705 released March 30, 2000 and Public Notice DA00-1407 released June 26, 2000.
2. The system was configured for testing a typical fashion (as a customer would normally use it.).
3. Radiate testing in the range of 1GHz to 25GHz was investigated with the spectrum (peak detector function) under the FCC regulation section 15.209 (e) and 15.35 (b). For above 18GHz, test performed at an antenna to EUT distance of 1 meter. The level of any unwanted emissions from EUT did not exceed the level of the fundamental emission (Compliance with 15.209 (c)). And test result found to be compliance with FCC regulation section 15.209 (a) Radiated emission limits (500uV/m). Data is presented for the “worst case” measurements, that EUT was normal operated.
4. Radiate testing in the range of 30MHz to 1000MHz was performed at an antenna to EUT distance of 3 meters under the 15.209 (e) and 15.31(f)(1).
5. Tests were performed with the representative channel operation as follows.
 - a. Lowest Frequency Channel: 0ch 2402MHz
 - b. Middle Frequency Channel: 39ch 2441MHz
 - c. Highest Frequency Channel: 78ch 2480MHz

3.2 Operating Modes

Transmitting Mode

Type of Modulation		GFSK, $\pi/4$ -DQPSK and 8DPSK
Signal Pattern		PRBS9
Signal Packet Type	GFSK	DH5
	$\pi/4$ -DQPSK	2-DH5
	8DPSK	3-DH5
Representative Channel		0ch 2402MHz (Lowest Frequency Channel)
		39ch 2441MHz (Middle Frequency Channel)
		78ch 2480MHz (Highest Frequency Channel)

Remarks:

Signal Pattern PRBS9:	<u>Periodic Pseudo Random Bit Sequence. $2^9 - 1$</u>
Signal Packet Type:	
DH5:	<u>Data high rate, ACL type packet</u> <u>Data payload with CRC, without FEC</u> <u>Fully transmission within one consecutive 625us transmission slots</u> <u>Number of slot = 5</u> <u>Data size of payload = 339 bytes</u>
2-DH5:	<u>This packet is similar to the DH5 packet except that the payload is modulated using $\pi/4$-DQPSK. The 2-DH5 packet has between 2 and 681 information bytes (including the 2 byte payload header) plus a 16bit CRC code. The 2-DH5 packet may occupy up to five time slots.</u>
3-DH5:	<u>This packet is similar to the DH5 packet except that the payload in modulated using 8DPSK. The 3-DH5 packet has between 2 and 1023 information bytes (including the 2 byte payload header) plus a 16bit CRC code. The 3-DH5 packet may occupy up to five time slots.</u>
Software (Controller):	<u>Blue Test ver2.0.0.0 software supplied by CSR Company was used to set up the Bluetooth operating mode.</u> <u>BTcli ver2.0.0.0 software supplied by CSR Company was used to set up to the Bluetooth operating mode except for AFH operating mode.</u>

3.3 Configuration of Tested System

(1) Conducted RF Test via Antenna Terminal

These numbers and the marks in the picture are corresponding to the numbers and the marks in tables shown.
 Power Supply of EUT: DC 3.3V from Supporting Equipment “b”.

(Supporting Equipment “b” was supplied by Regulated DC Power Supply “c”)

Test Setting for Normal Frequency Hopping, Non Frequency Hopping and Adaptive Frequency Hopping Mode

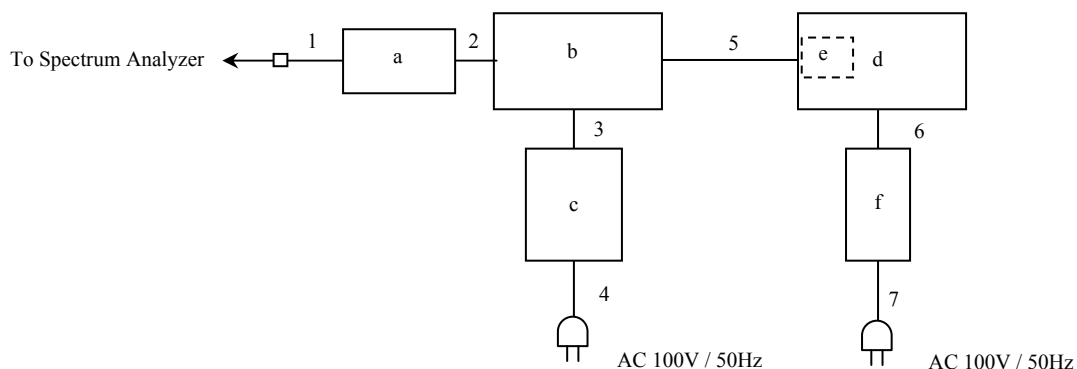

List of EUT and Accessories

	Product Name	Model No.	Serial No.	Manufacturer	EUT / Accessory	Notes
a	Bluetooth Module	BTU-3586	9	Clarion	EUT	-
b	Supporting Equipment	PF-3293-E00	4	Clarion	Accessory	-
c	Regulated DC Power Supply	PA18-3A	LK000371	KIKUSUI	Accessory	-
d	Note PC	2662-LFJ	FX-DL088	IBM	Accessory	-
e	PC card	8510-00054L	0310000262	Socket	Accessory	-
f	AC Adapter for Note PC	02K6810	9	IBM	Accessory	-

Interface Cables

	Cable Type	Model No.	Shielded	Ferrite Core	Length	Notes
1	RF Cable	-	No	No	0.30m	-
2	Bus Cable	-	No	No	0.29m	-
3	DC Cable	-	No	No	0.77m	-
4	AC Cable	-	No	No	1.80m	-
5	RS232C Cable	-	No	No	1.08m	-
6	DC Cable	-	No	No	1.80m	-
7	AC Cable	-	No	No	1.05m	-

(2) Radiated Emission Test

These numbers and the marks in the picture are corresponding to the numbers and the marks in tables shown.
 Power Supply of EUT: DC 3.3V from Supporting Equipment “b”.
 (Supporting Equipment “b” was supplied by Regulated DC Power Supply “c”)

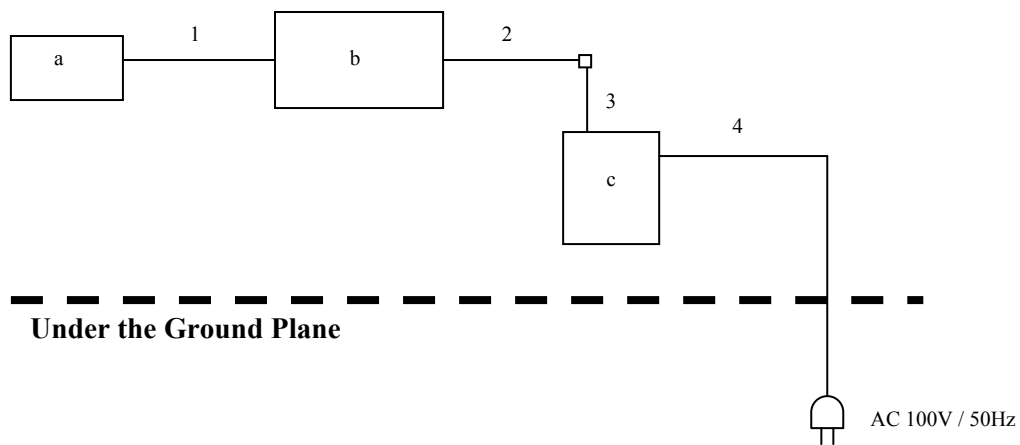

List of EUT and Accessories

	Product Name	Model No.	Serial No.	Manufacturer	EUT / Accessory	FCC ID / DoC
a	Bluetooth Module	BTU-3586	47	Clarion	EUT	SJ2QY7200
b	Supporting Equipment	PF-3293-E00	4	Clarion	Accessory	-
c	Regulated DC Power Supply	PMC18-5A	NE001553	KIKUSUI	Accessory	-

Interface Cables

	Cable Type	Model No.	Shielded	Ferrite Core	Length	Treatment for the Extra Length
1	Bus Cable	-	No	No	0.29m	-
2	DC Cable	-	No	No	0.77m	-
3	DC Cable	-	No	No	0.51m	-
4	AC Cable	-	No	No	2.40m	-

3.4 Test Instruments

About test instruments for all tests, please refer to appendix 3.

4 Antenna Requirement

The EUT provides a permanently attached antenna and it was found to be compliant with FCC regulation section 15.203.

Antenna Type	Inverted F
Antenna Gain	1.60dBi

5 AC Powerline Conducted Emission

N/A

This EUT is intended for use in vehicles. So this measurement is not applied to this EUT.

6 20dB Bandwidth

6.1 Test Setup

The spectrum analyzer was connected to the transmitter output port through the RF cable.

Spectrum Analyzer Setting:

Detector Mode	Peak
RBW	30kHz
VBW	30kHz
Span	2MHz
Sweep Time	Auto

6.2 Test Results

Serial No. : 9
 Power : DC 3.3V
 Mode : Transmitting Mode, Non Frequency Hopping
 Temperature : 25.3 degree C
 Humidity : 50.9 %

(1) GFSK Modulation

Channel	Frequency [MHz]	20dB Bandwidth [MHz]
0ch (Lowest)	2402.0	0.942
39ch (Middle)	2441.0	0.942
78ch (Highest)	2480.0	0.878

(2) $\pi/4$ -DQPSK Modulation

Channel	Frequency [MHz]	20dB Bandwidth [MHz]
0ch (Lowest)	2402.0	1.263
39ch (Middle)	2441.0	1.247
78ch (Highest)	2480.0	1.255

(3) 8DPSK Modulation

Channel	Frequency [MHz]	20dB Bandwidth [MHz]
0ch (Lowest)	2402.0	1.275
39ch (Middle)	2441.0	1.271
78ch (Highest)	2480.0	1.271

7 Carrier Frequency Separation

7.1 Test Setup

The spectrum analyzer was connected to the transmitter output port through the RF cable.

Spectrum Analyzer Setting:

Detector Mode	Peak
RBW	100kHz
VBW	300kHz
Span	3MHz
Sweep Time	Auto

7.2 Test Results

Serial No. : 9
 Power : DC 3.3V
 Mode : Transmitting Mode, Frequency Hopping
 Transmitting Mode, AFH
 Temperature : 25.3 degree C
 Humidity : 50.9 %
 Regulation : FCC Part15 C §15.247 (a)(1)

(1) GFSK Modulation Frequency Hopping (79ch)

Channel	Channel Separation [MHz]	Limit *1 [MHz]
0ch-1ch (Lowest)	0.998	> 0.629
38ch-39ch (Middle)	0.986	> 0.629
77ch-78ch (Highest)	1.016	> 0.586

Adaptive Frequency Hopping (20ch)

Channel	Channel Separation [MHz]	Limit *1 [MHz]
0ch-1ch (Lowest)	1.010	> 0.629
38ch-39ch (Middle)	0.998	> 0.629
77ch-78ch (Highest)	1.004	> 0.586

*1: Limit value of Carrier Frequency Separation is 2 / 3 of 20dB Bandwidth.
 Limit is two-thirds of the 20dB bandwidth of the hopping channel provided the systems operate with an output power no greater than 125mW.
 Refer the result of 20dB Bandwidth to Section 6.

(2) $\pi/4$ -DQPSK Modulation
Frequency Hopping (79ch)

Channel	Channel Separation [MHz]	Limit *1 [MHz]
0ch-1ch (Lowest)	1.004	>0.842
38ch-39ch (Middle)	1.004	>0.832
77ch-78ch (Highest)	1.010	>0.837

Adaptive Frequency Hopping (20ch)

Channel	Channel Separation [MHz]	Limit *1 [MHz]
0ch-1ch (Lowest)	0.992	>0.842
38ch-39ch (Middle)	1.004	>0.832
77ch-78ch (Highest)	1.022	>0.837

*1: Limit value of Carrier Frequency Separation is 2 / 3 of 20dB Bandwidth.
Limit is two-thirds of the 20dB bandwidth of the hopping channel provided the systems operate with an output power no greater than 125mW.
Refer the result of 20dB Bandwidth to Section 5.

(3) 8DPSK Modulation
Frequency Hopping (79ch)

Channel	Channel Separation [MHz]	Limit *1 [MHz]
0ch-1ch (Lowest)	1.010	>0.850
38ch-39ch (Middle)	0.998	>0.848
77ch-78ch (Highest)	1.004	>0.848

Adaptive Frequency Hopping (20ch)

Channel	Channel Separation [MHz]	Limit *1 [MHz]
0ch-1ch (Lowest)	1.010	>0.850
38ch-39ch (Middle)	0.998	>0.848
77ch-78ch (Highest)	1.016	>0.848

*1: Limit value of Carrier Frequency Separation is 2 / 3 of 20dB Bandwidth.
Limit is two-thirds of the 20dB bandwidth of the hopping channel provided the systems operate with an output power no greater than 125mW.
Refer the result of 20dB Bandwidth to Section 5.

8 Number of Hopping Frequency

8.1 Test Setup

The spectrum analyzer was connected to the transmitter output port through the RF cable.

Spectrum Analyzer Setting:

Detector Mode	Peak
RBW	300kHz
VBW	300kHz
Sweep Time	Auto

8.2 Test Results

Serial No. : 9
 Power : DC 3.3V
 Mode : Transmitting Mode, Frequency Hopping
 Transmitting Mode, AFH
 Temperature : 25.3 degree C
 Humidity : 50.9 %
 Regulation : FCC Part15 C §15.247 (a)(1)(iii)

(1) GFSK Modulation

Mode	Number of Channel [times]	Limit [times]
Frequency Hopping (79ch)	79	>= 75
Adaptive Frequency Hopping (20ch)	20	>= 15

(2) $\pi/4$ -DQPSK Modulation

Mode	Number of Channel [times]	Limit [times]
Frequency Hopping (79ch)	79	>=75
Adaptive Frequency Hopping (20ch)	20	>=15

(3) 8DPSK Modulation

Mode	Number of Channel [times]	Limit [times]
Frequency Hopping (79ch)	79	>=75
Adaptive Frequency Hopping (20ch)	20	>=15

9 Dwell Time

9.1 Test Setup

The spectrum analyzer was connected to the transmitter output port through the RF cable.

Spectrum Analyzer Setting:

Detector Mode	Peak
RBW	1MHz
VBW	1MHz
Span	0Hz
Sweep Time	Auto

9.2 Test Results

Serial No. : 9
 Power : DC 3.3V
 Mode : Transmitting Mode, Frequency Hopping
 Transmitting Mode, AFH
 Temperature : 25.3 degree C
 Humidity : 50.9 %
 Regulation : FCC Part15 C §15.247 (a)(1)(iii)

(1) GFSK Modulation

Frequency Hopping (79ch)			Adaptive Frequency Hopping (20ch)		
Channel	Dwell Time [ms]	Limit [ms]	Channel	Dwell Time [ms]	Limit [ms]
0ch (Lowest)	309.46	<= 400	0ch (Lowest)	311.20	<= 400
39ch (Meddle)	309.46	<= 400	39ch (Meddle)	310.13	<= 400
78ch (Highest)	309.46	<= 400	78ch (Highest)	311.20	<= 400

(2) $\pi/4$ -DQPSK Modulation

Frequency Hopping (79ch)			Adaptive Frequency Hopping (20ch)		
Channel	Dwell Time [ms]	Limit [ms]	Channel	Dwell Time [ms]	Limit [ms]
0ch (Lowest)	310.52	<= 400	0ch (Lowest)	311.20	<= 400
39ch (Meddle)	310.52	<= 400	39ch (Meddle)	310.13	<= 400
78ch (Highest)	310.52	<= 400	78ch (Highest)	311.20	<= 400

(3) 8DPSK Modulation

Frequency Hopping (79ch)			Adaptive Frequency Hopping (20ch)		
Channel	Dwell Time [ms]	Limit [ms]	Channel	Dwell Time [ms]	Limit [ms]
0ch (Lowest)	310.52	<=400	0ch (Lowest)	311.20	<=400
39ch (Meddle)	312.65	<=400	39ch (Meddle)	312.26	<=400
78ch (Highest)	312.65	<=400	78ch (Highest)	311.20	<=400

Data of Dwell Time (Frequency Hopping (79ch))

Worst-Case of Frequency Hopping (79ch) is shown the following.

Time of Occupancy (Dwell Time) for GFSK Modulation

The frequency-hopping rate of Bluetooth system is 1600 hops per 1s.
A DH5 packet needs 5 times slot for transmitting and 1 time slot for receiving.

In a DH5 packet, it hops 266.67 times for transmitting per 1s.
The number of hopping channel is 79.
The number of times that appears in 1 channel per 1s is as follows.
 $266.67 / 79 = 3.37$ times

The average time of occupancy on any channel shall not be greater than 0.4s (400ms) within a period of 0.4s multiplied by the number of hopping channels employed $0.4 * 79 = 31.6s$
The number of times that appears in 1 channel per 31.6s is as follows.
 $3.37 * 31.6 = 106.49$ times

Transmitting time is 2.906ms.
Then, dwell time is $106.49 * 2.906ms = 309.46ms$ per 31.6s.

Time of Occupancy (Dwell Time) for $\pi/4$ -DQPSK Modulation

The frequency-hopping rate of Bluetooth system is 1600 hops per 1s.
A DH5 packet needs 5 times slot for transmitting and 1 time slot for receiving.

In a DH5 packet, it hops 266.67 times for transmitting per 1s.
The number of hopping channel is 79.
The number of times that appears in 1 channel per 1s is as follows.
 $266.67 / 79 = 3.37$ times

The average time of occupancy on any channel shall not be greater than 0.4s (400ms) within a period of 0.4s multiplied by the number of hopping channels employed $0.4 * 79 = 31.6s$
The number of times that appears in 1 channel per 31.6s is as follows.
 $3.37 * 31.6 = 106.49$ times

Transmitting time is 2.916ms.
Then, dwell time is $106.49 * 2.916ms = 310.52ms$ per 31.6s.

Time of Occupancy (Dwell Time) for 8DPSK Modulation

The frequency-hopping rate of Bluetooth system is 1600 hops per 1s.
A DH5 packet needs 5 times slot for transmitting and 1 time slot for receiving.

In a DH5 packet, it hops 266.67 times for transmitting per 1s.
The number of hopping channel is 79.
The number of times that appears in 1 channel per 1s is as follows.
 $266.67 / 79 = 3.37$ times

The average time of occupancy on any channel shall not be greater than 0.4s (400ms) within a period of 0.4s multiplied by the number of hopping channels employed $0.4 * 79 = 31.6s$
The number of times that appears in 1 channel per 31.6s is as follows.
 $3.37 * 31.6 = 106.49$ times

Transmitting time is 2.936ms.
Then, dwell time is $106.49 * 2.936ms = 312.65ms$ per 31.6s.

Data of Dwell Time (Adaptive Frequency Hopping (20ch))

Worst-Case of AFH (20ch) is shown the following.

Time of Occupancy (Dwell Time) for GFSK Modulation

The frequency-hopping rate of Bluetooth system is 1600 hops per 1s.
A DH5 packet needs 5 times slot for transmitting and 1 time slot for receiving.

In a DH5 packet, it hops 266.67 times for transmitting per 1s.
The number of hopping channel is 20.
The number of times that appears in 1 channel per 1s is as follows.
 $266.67 / 20 = 13.34$ times

The average time of occupancy on any channel shall not be greater than 0.4s (400ms) within a period of 0.4s multiplied by the number of hopping channels employed $0.4 * 20 = 8.0s$
The number of times that appears in 1 channel per 8.0s is as follows.
 $13.34 * 8.0 = 106.72$ times

Transmitting time is 2.916ms.
Then, dwell time is $106.72 * 2.916ms = 311.20ms$ per 8.0s.

Time of Occupancy (Dwell Time) for $\pi/4$ -DQPSK Modulation

The frequency-hopping rate of Bluetooth system is 1600 hops per 1s.
A DH5 packet needs 5 times slot for transmitting and 1 time slot for receiving.

In a DH5 packet, it hops 266.67 times for transmitting per 1s.
The number of hopping channel is 20.
The number of times that appears in 1 channel per 1s is as follows.
 $266.67 / 20 = 13.34$ times

The average time of occupancy on any channel shall not be greater than 0.4s (400ms) within a period of 0.4s multiplied by the number of hopping channels employed $0.4 * 20 = 8.0s$
The number of times that appears in 1 channel per 8.0s is as follows.
 $13.34 * 8.0 = 106.72$ times

Transmitting time is 2.916ms.
Then, dwell time is $106.72 * 2.916ms = 311.20ms$ per 8.0s.

Time of Occupancy (Dwell Time) for 8DPSK Modulation

The frequency-hopping rate of Bluetooth system is 1600hops per 1s.
A DH5 packet needs 5 times slot for transmitting and 1 time slot for receiving.

In a DH5 packet, it hops 266.67 times for transmitting per 1s.
The number of hopping channel is 20.
The number of times that appears in 1 channel per 1s is as follows.
 $266.67 / 20 = 13.34$ times

The average time of occupancy on any channel shall not be greater than 0.4s (400ms) within a period of 0.4s multiplied by the number of hopping channels employed $0.4 * 20 = 8.0s$
The number of times that appears in 1 channel per 8.0s is as follows.
 $13.34 * 8.0 = 106.72$ times

Transmitting time is 2.926ms.
Then, dwell time is $106.72 * 2.926ms = 312.26ms$ per 8.0s.

10 Maximum Peak Output Power

10.1 Test Setup

The spectrum analyzer was connected to the transmitter output port through the RF cable.

Spectrum Analyzer Setting:

Detector Mode	Peak
RBW	1MHz
VBW	1MHz
Span	5MHz
Sweep Time	Auto

10.2 Test Results

Serial No. : 9
 Power : DC 3.3V
 Mode : Transmitting Mode, Non Frequency Hopping
 Temperature : 25.3 degree C
 Humidity : 50.9 %
 Regulation : FCC Part15 C §15.247 (b)(1)

(1) GFSK Modulation

Channel	Frequency [MHz]	Reading [dBm]	Cable Loss1 [dB]	Cable Loss2 [dB]	Result		Limit	
					[dBm]	[mW]	[dBm]	[mW]
0ch (Lowest)	2402	1.46	0.69	0.50	2.65	1.841	< 30	< 1000
39ch (Middle)	2441	1.13	0.64	0.50	2.27	1.687	< 30	< 1000
78ch (Highest)	2480	0.40	0.64	0.50	1.54	1.426	< 30	< 1000

Result = Reading + Cable Loss1 + Cable Loss2

Note: Cable Loss1: RF Cable

Cable Loss2: Conversion cable used for connecting to SMA type

(2) $\pi/4$ -DQPSK Modulation

Channel	Frequency [MHz]	Reading [dBm]	Cable Loss1 [dB]	Cable Loss2 [dB]	Result		Limit	
					[dBm]	[mW]	[dBm]	[mW]
0ch (Lowest)	2402	2.66	0.69	0.50	3.85	2.427	< 30	< 1000
39ch (Middle)	2441	2.34	0.64	0.50	3.48	2.228	< 30	< 1000
78ch (Highest)	2480	2.00	0.64	0.50	3.14	2.061	< 30	< 1000

Result = Reading + Cable Loss1 + Cable Loss2

Note: Cable Loss1: RF Cable

Cable Loss2: Conversion cable used for connecting to SMA type

(3) 8DPSK Modulation

Channel	Frequency [MHz]	Reading [dBm]	Cable Loss1 [dB]	Cable Loss2 [dB]	Result		Limit	
					[dBm]	[mW]	[dBm]	[mW]
0ch (Lowest)	2402	2.66	0.69	0.50	3.85	2.427	< 30	< 1000
39ch (Middle)	2441	2.52	0.64	0.50	3.66	2.323	< 30	< 1000
78ch (Highest)	2480	2.07	0.64	0.50	3.21	2.094	< 30	< 1000

Result = Reading + Cable Loss1 + Cable Loss2

Note: Cable Loss1: RF Cable

Cable Loss2: Conversion cable used for connecting to SMA type

11 Band Edge Compliance

11.1 Test Setup

The spectrum analyzer was connected to the transmitter output port through the RF cable.

Spectrum Analyzer Setting:

Detector Mode	Peak
RBW	100kHz
VBW	300kHz
Span	100MHz
Sweep Time	Auto

11.2 Test Results

Serial No.	:	9
Power	:	DC 3.3V
Mode	:	Transmitting Mode, Frequency Hopping Transmitting Mode, AFH Transmitting Mode, Non Frequency Hopping
Temperature	:	25.3 degree C
Humidity	:	50.9 %
Regulation	:	FCC Part15 C §15.247 (d)

The spectrum data are attached next page. Display line indicates the 20dB offset below highest level. It shows compliance with the requirement in part 15.247(d).

(1) GFSK Modulation

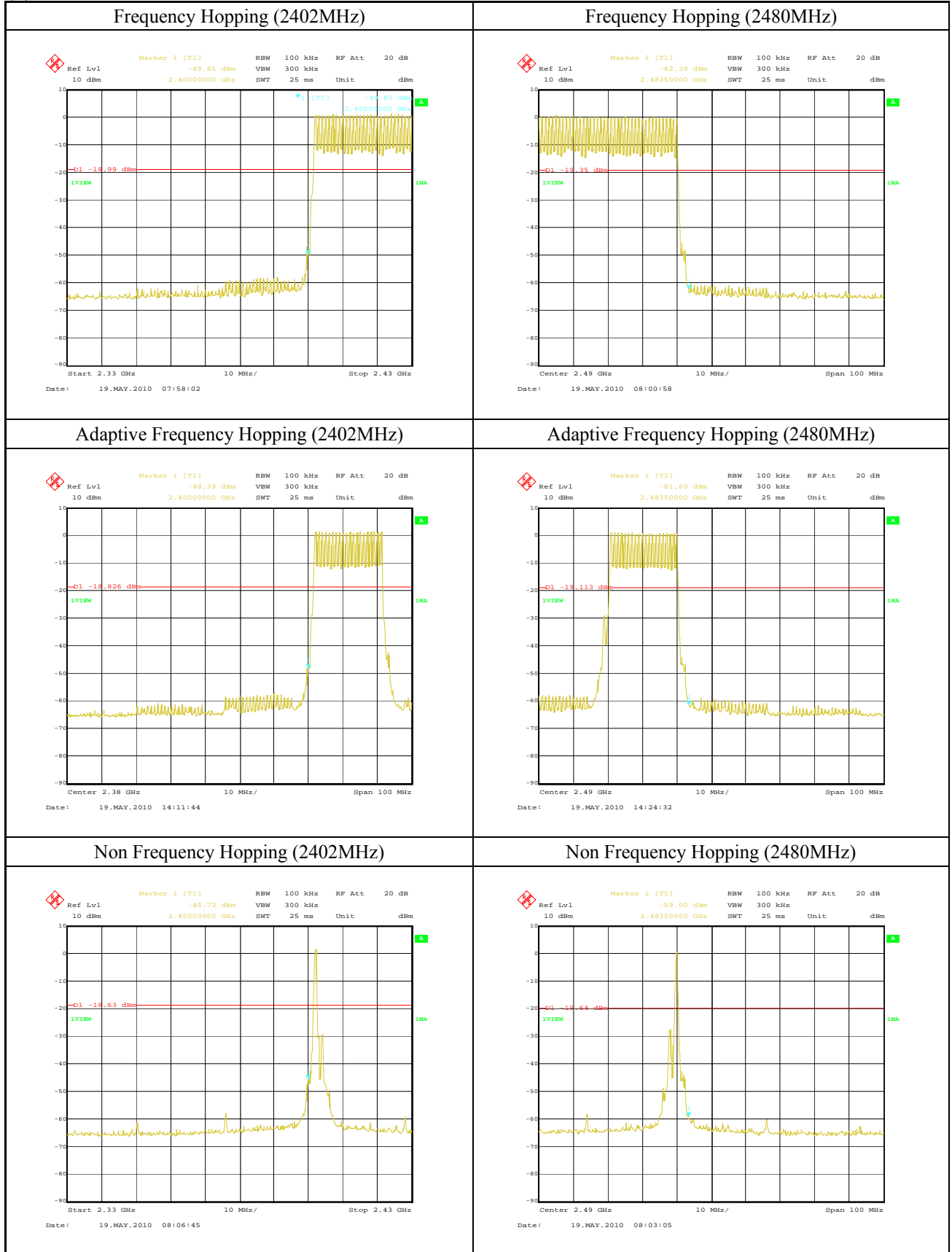

(2) $\pi/4$ -DQPSK Modulation

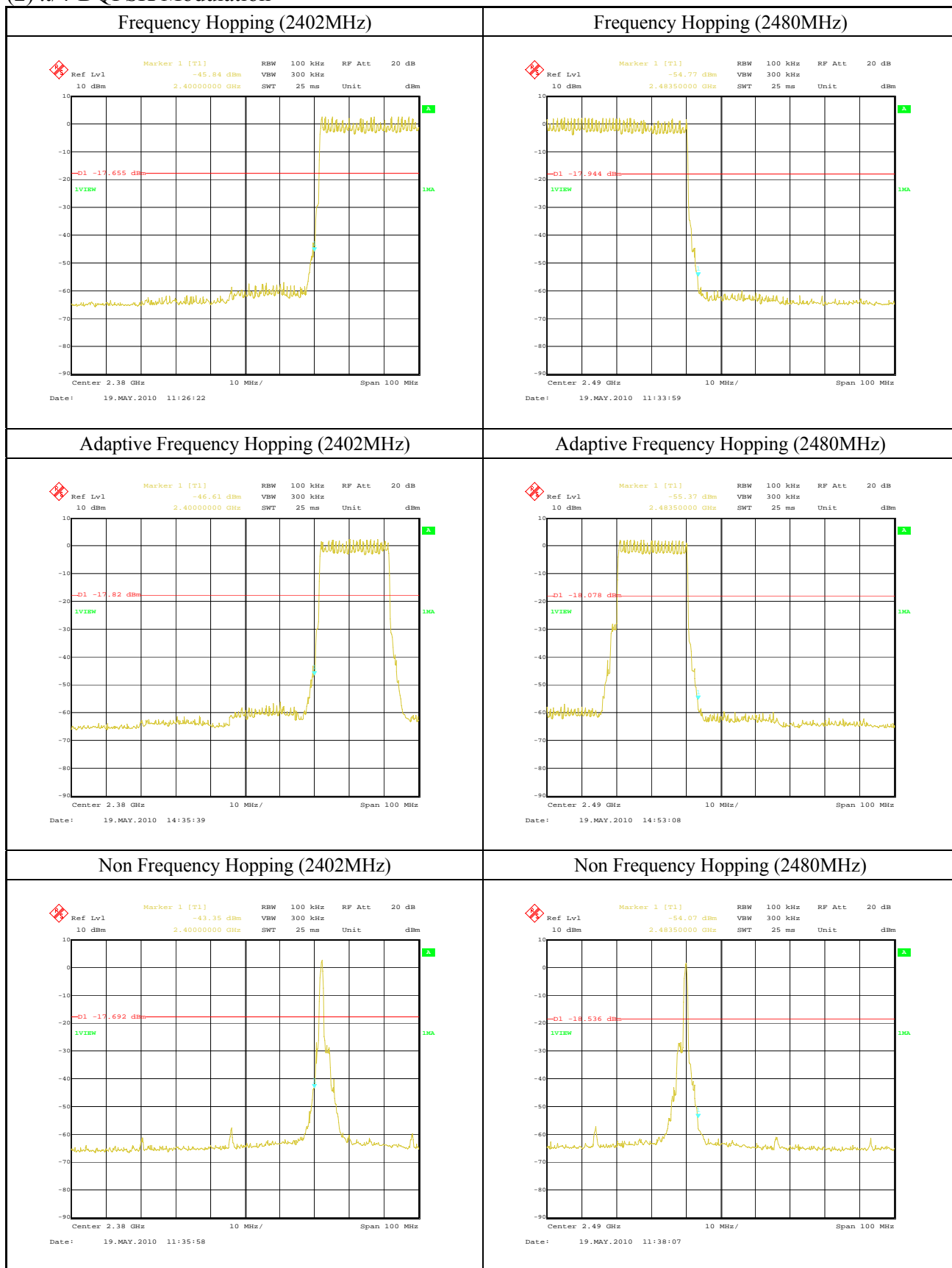

(3) 8DPSK Modulation



12 Spurious RF Conducted Emission

12.1 Test Setup

The spectrum analyzer was connected to the transmitter output port through the RF cable.

Spectrum Analyzer Setting:

Detector Mode	Peak
RBW	100kHz
VBW	300kHz
Sweep Time	Auto

12.2 Test Results

Serial No. : 9
Power : DC 3.3V
Mode : Transmitting Mode, Non Frequency Hopping
Temperature : 25.3 degree C
Humidity : 50.9 %
Regulation : FCC Part15 C §15.247 (d)

The spectrum data are attached next page. Display line indicates the 20dB offset below highest level. It shows compliance with the requirement in part 15.247(d).

(1) GFSK Modulation
 (i) 0ch (Lowest) 2402MHz

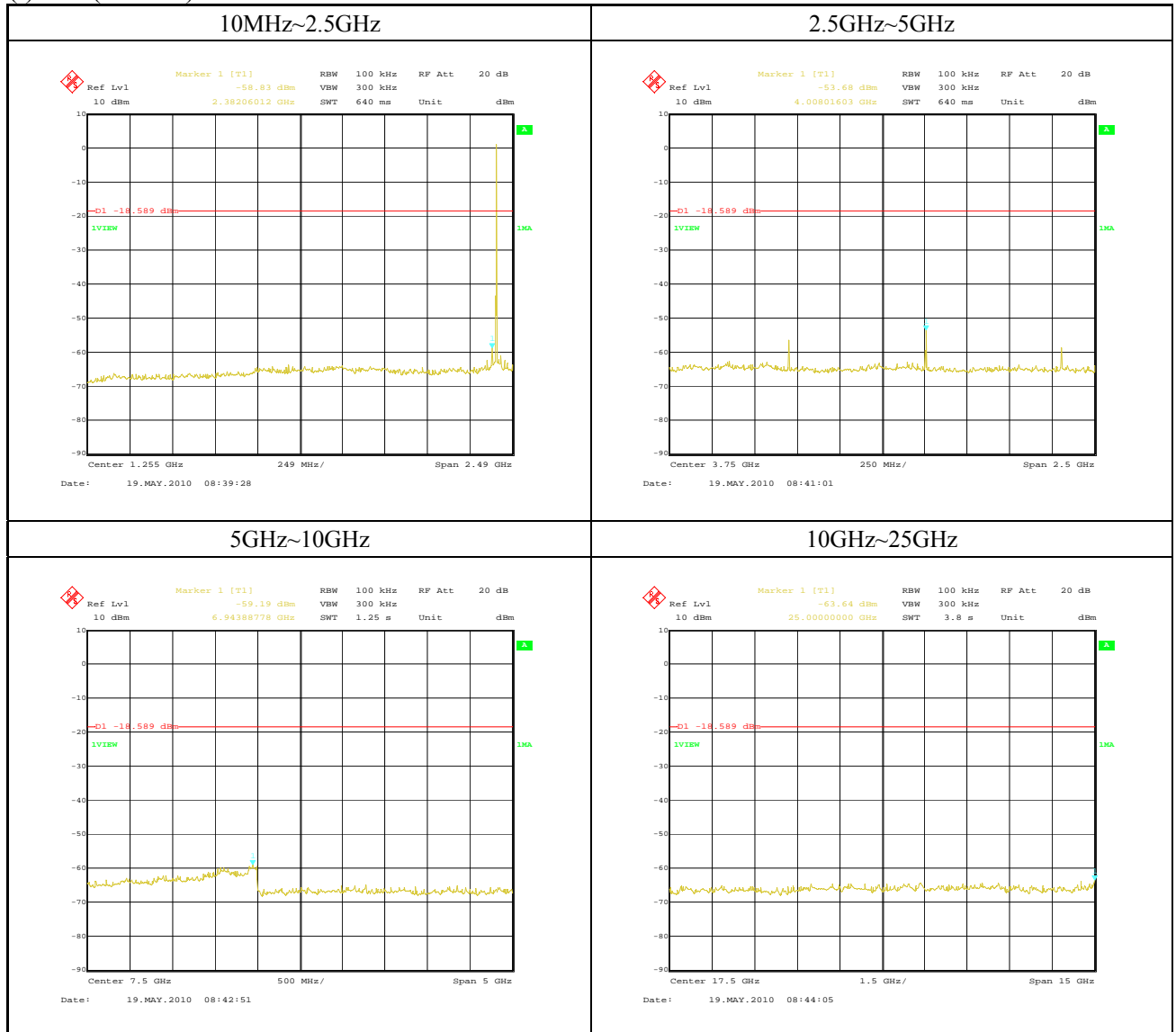

(ii) 39ch (Middle) 2441MHz

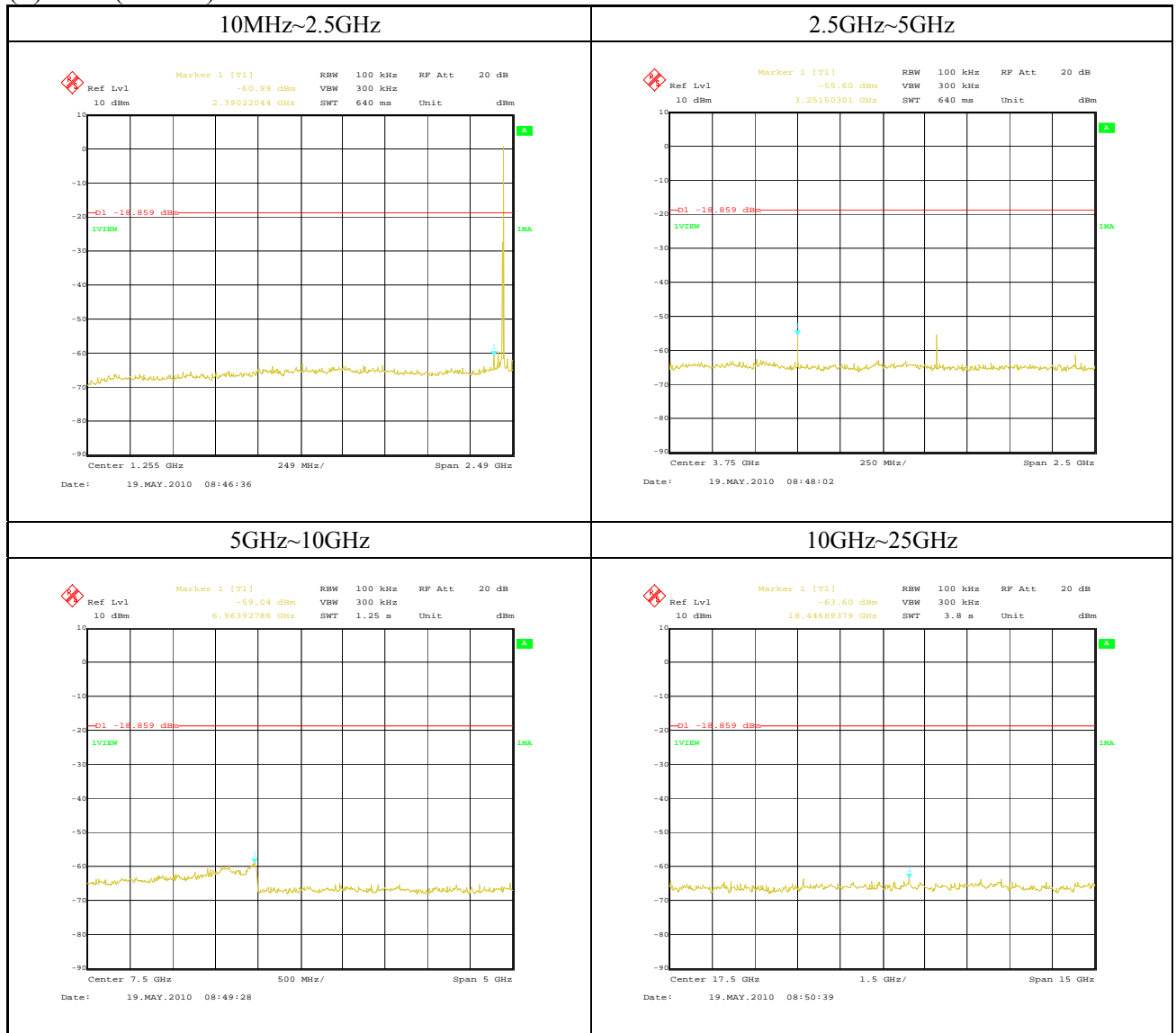

(iii) 78ch (Highest) 2480MHz

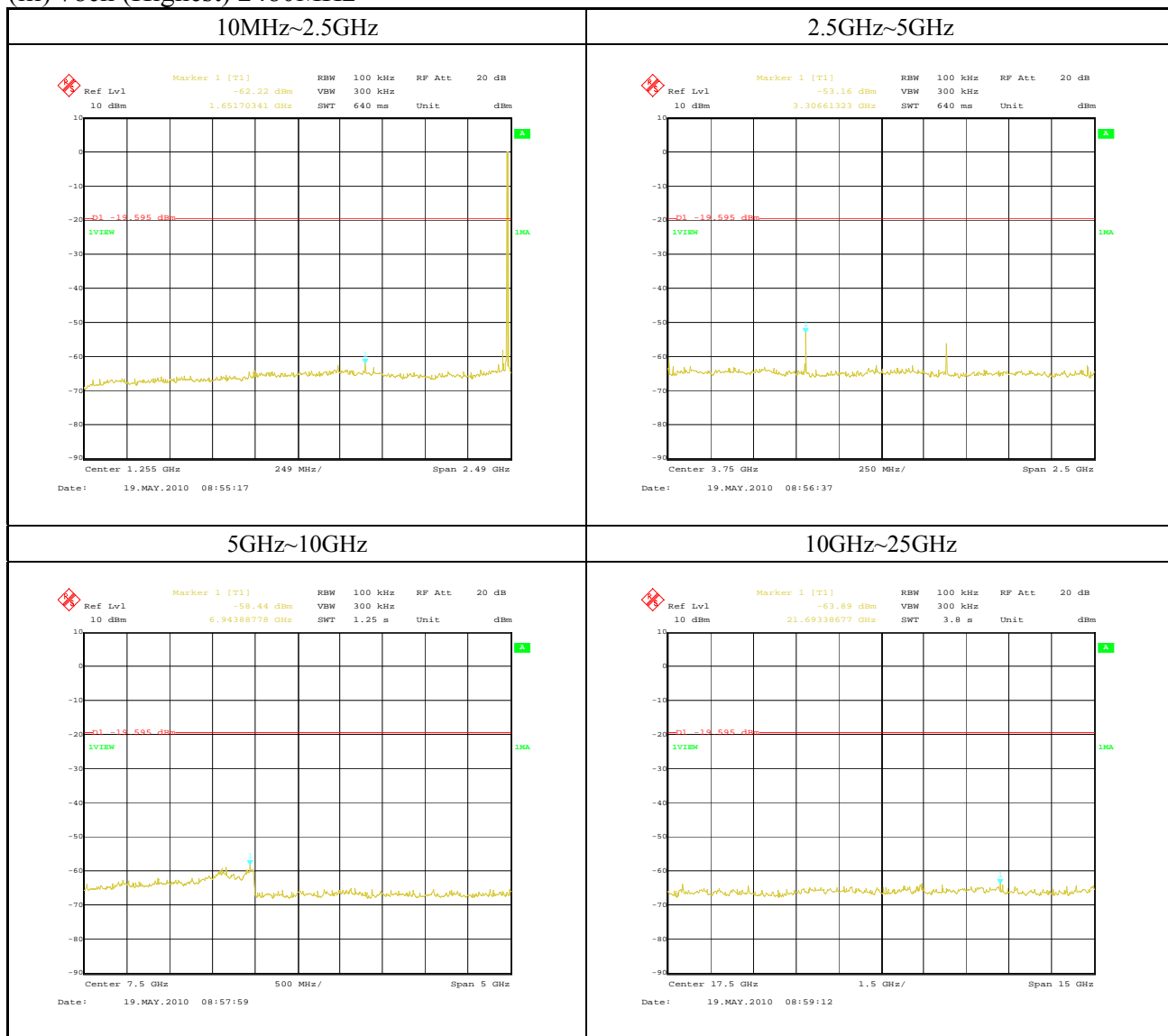

(2) $\pi/4$ -DQPSK Modulation
(i) 0ch (Lowest) 2402MHz

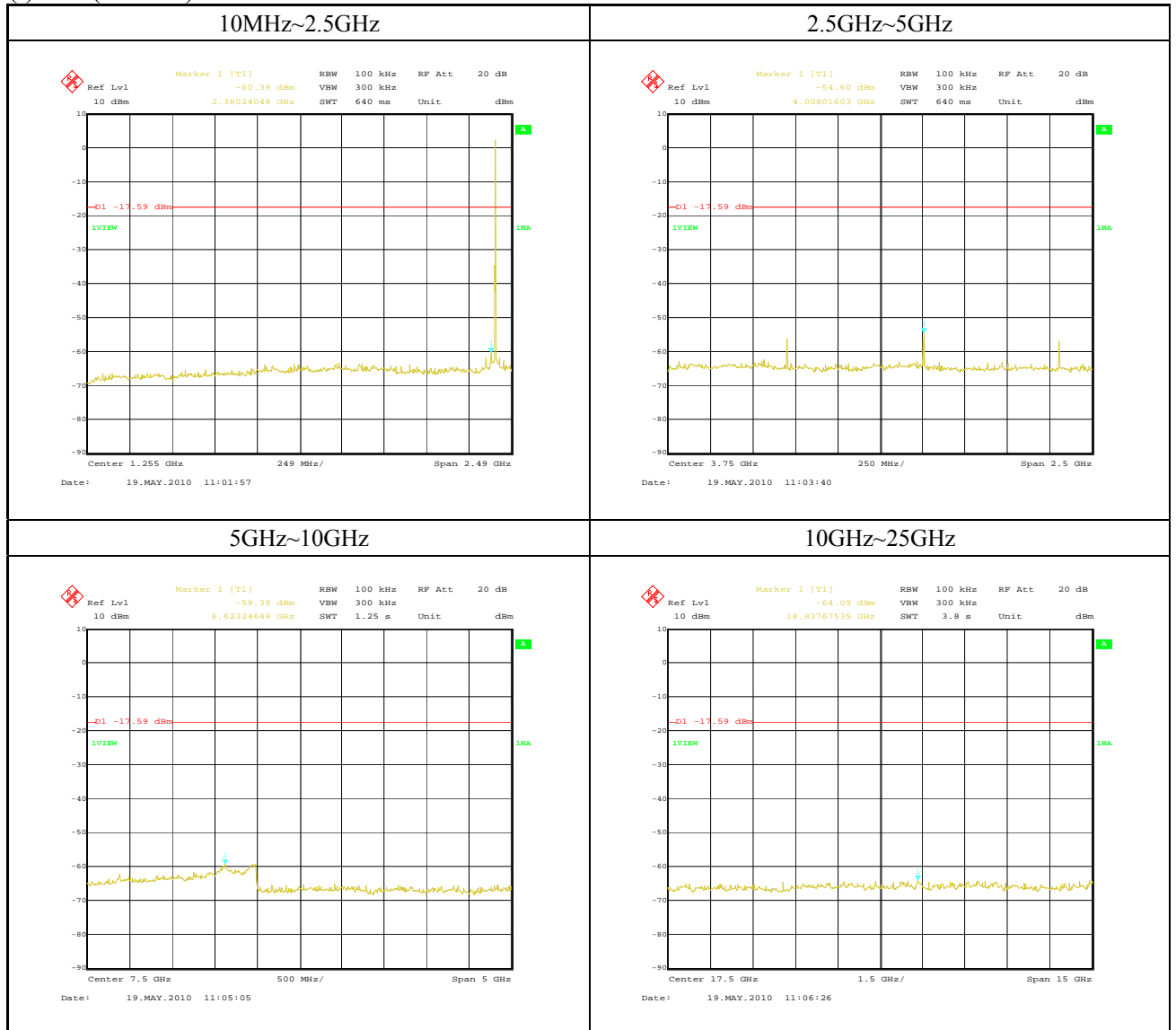

(ii) 39ch (Middle) 2441MHz

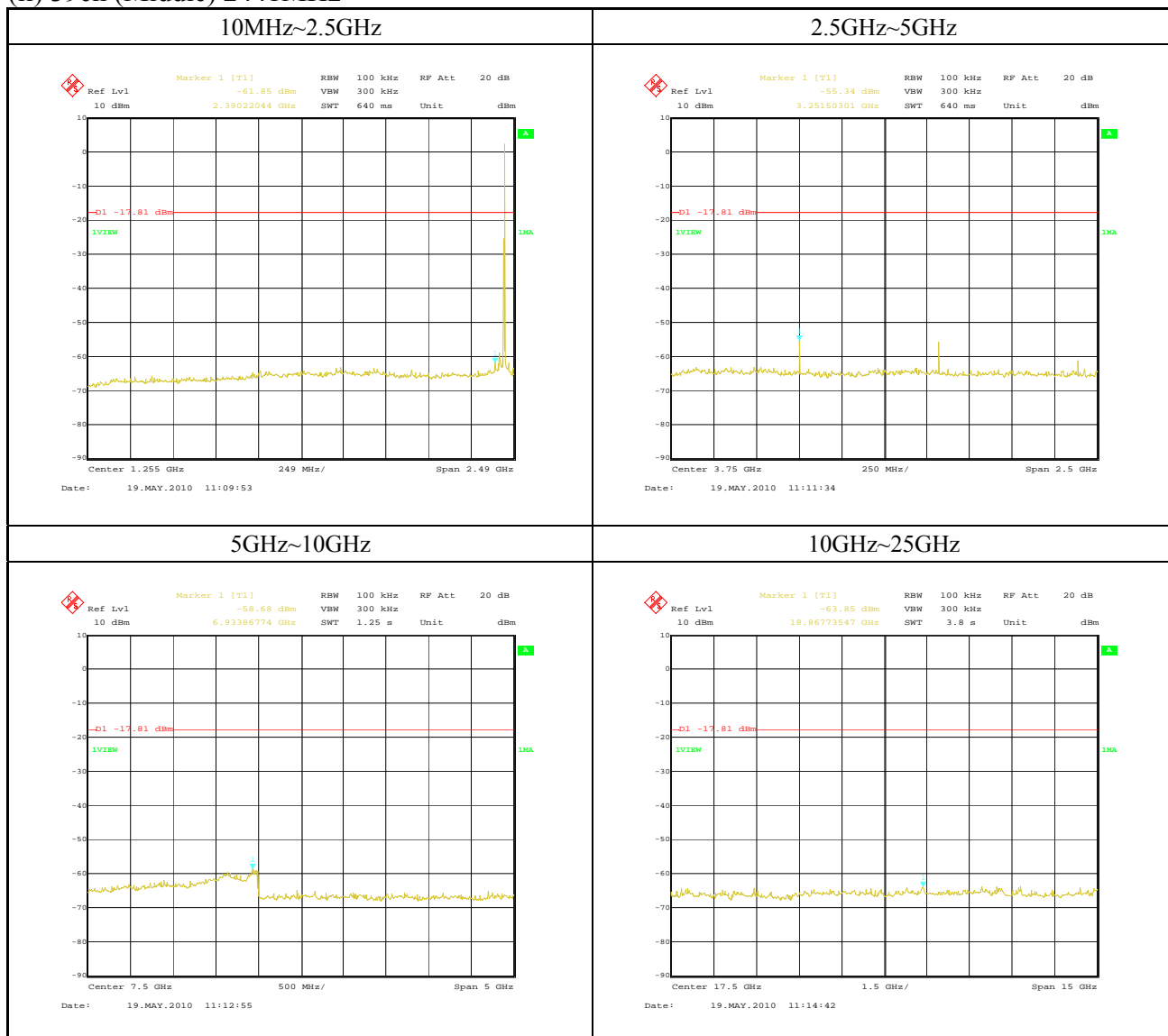

(iii) 78ch (Highest) 2480MHz

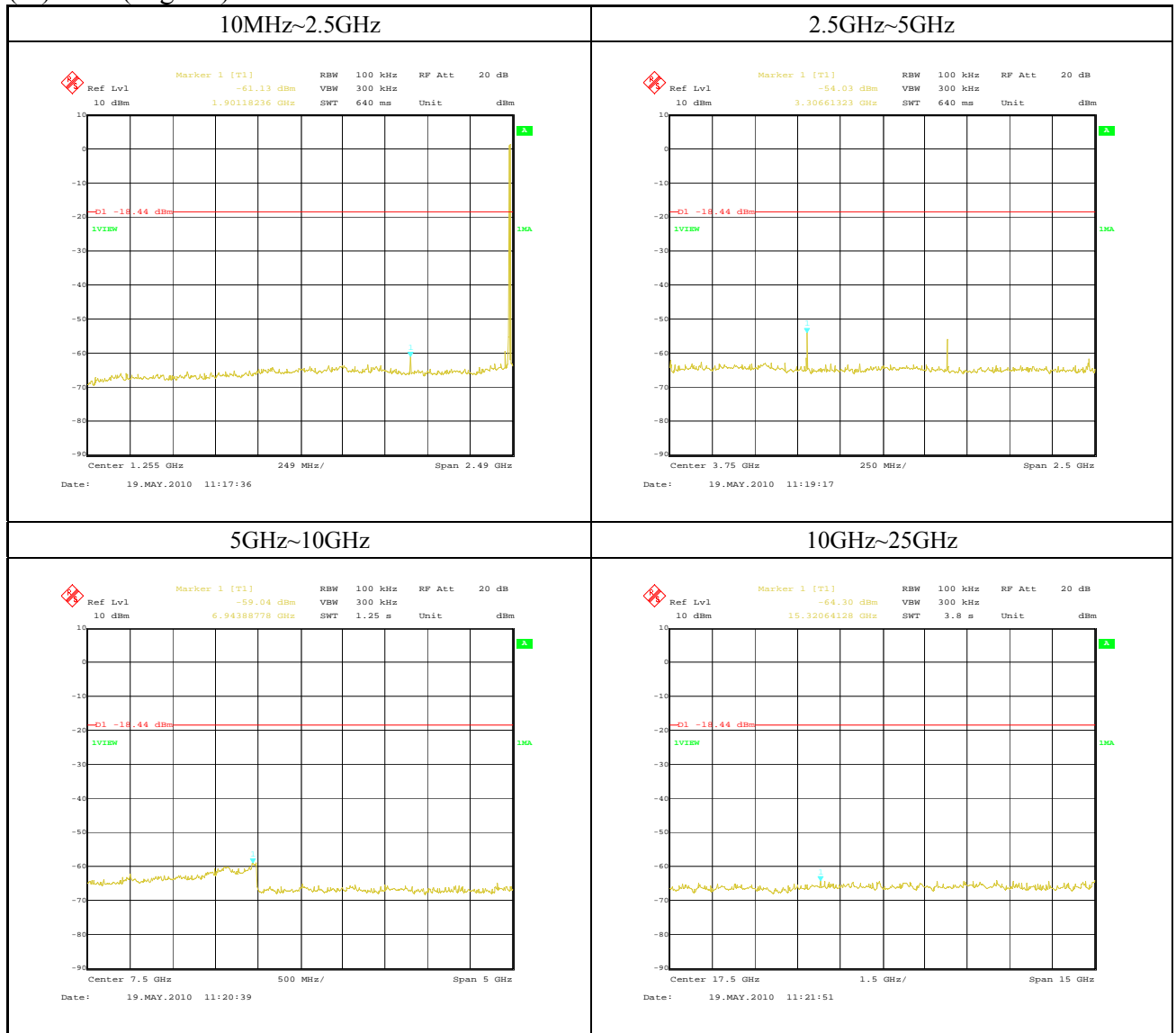

(3) 8DPSK Modulation
(i) 0ch (Lowest) 2402MHz

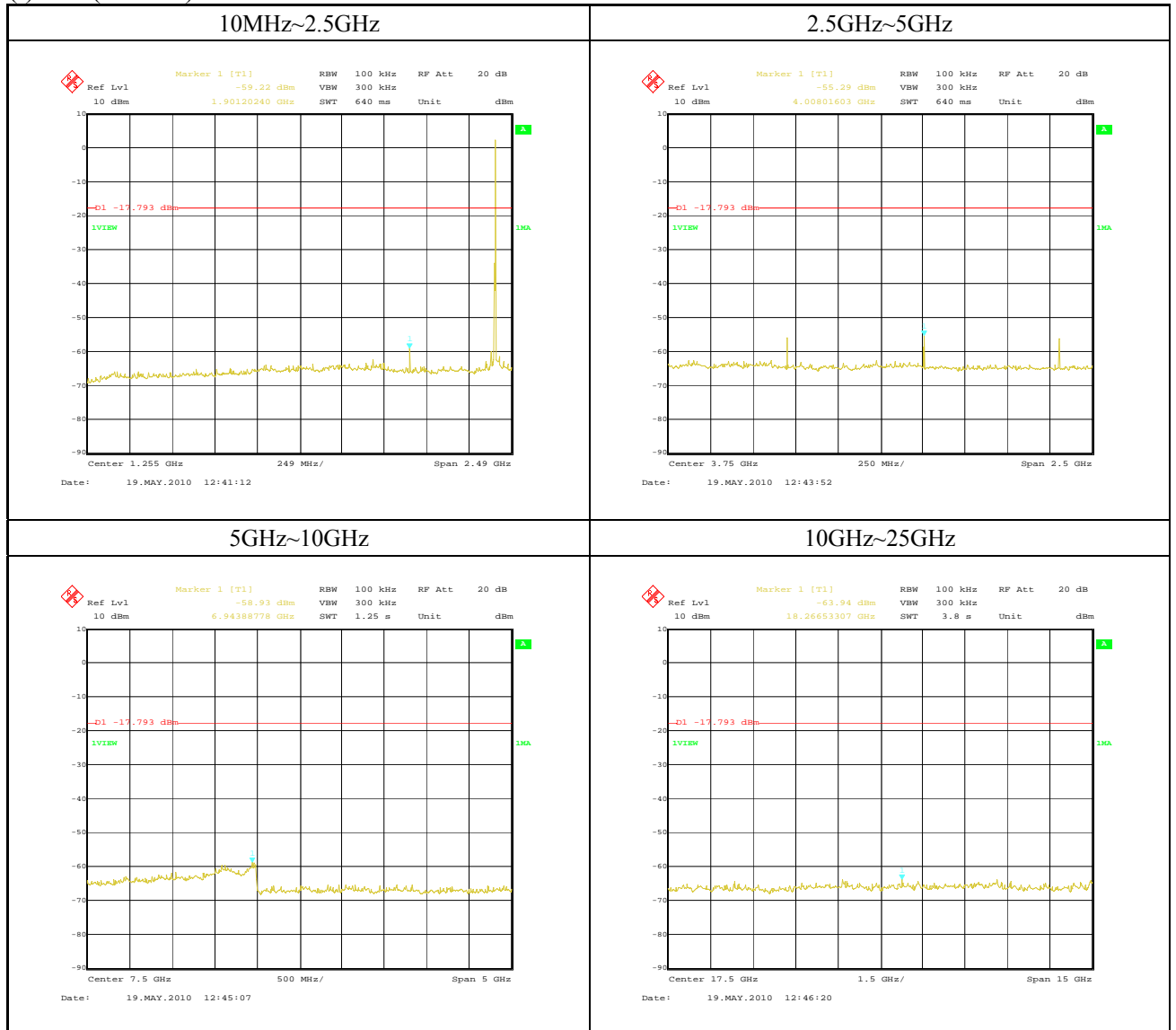

(ii) 39ch (Middle) 2441MHz

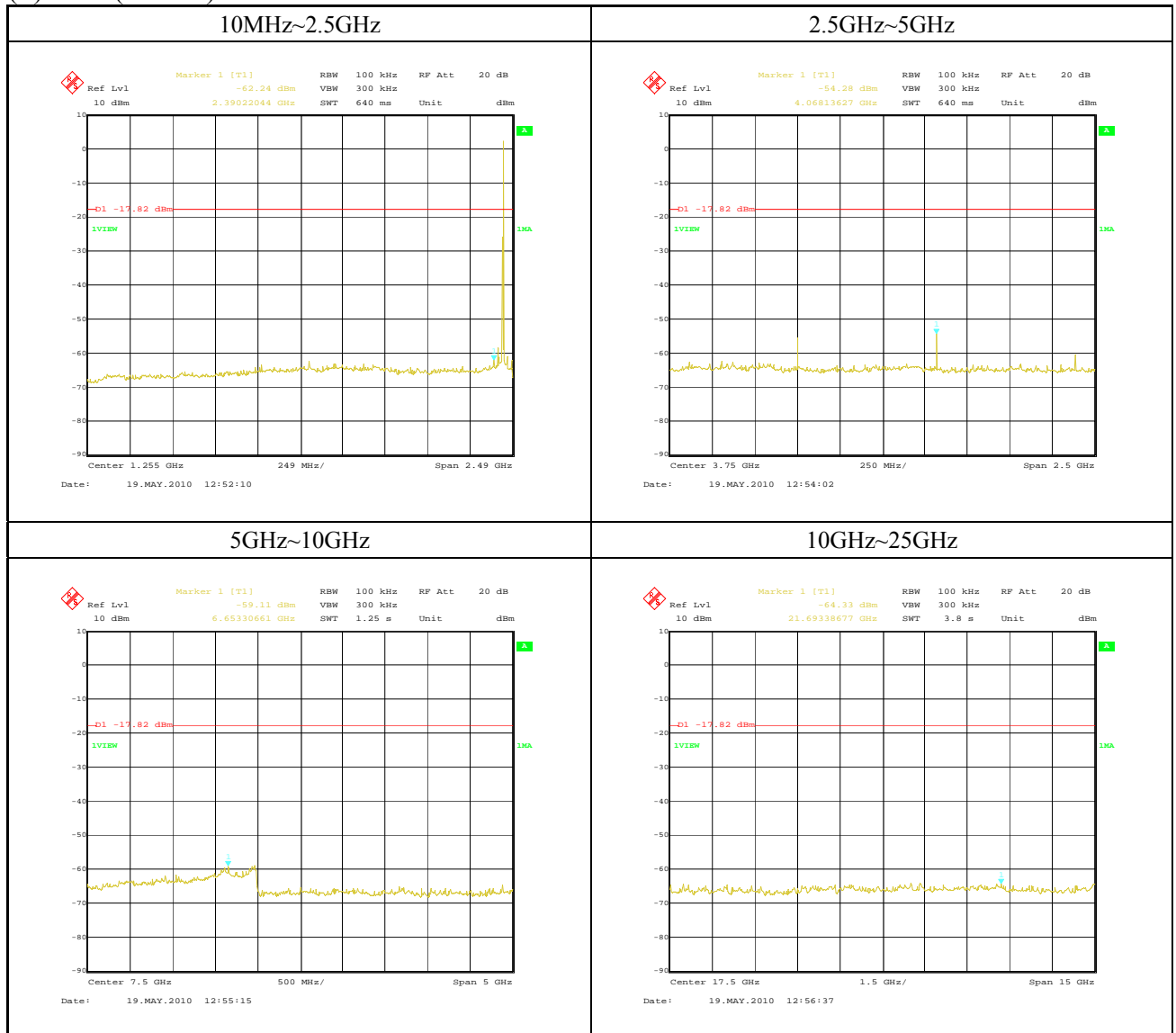

(iii) 78ch (Highest) 2480MHz

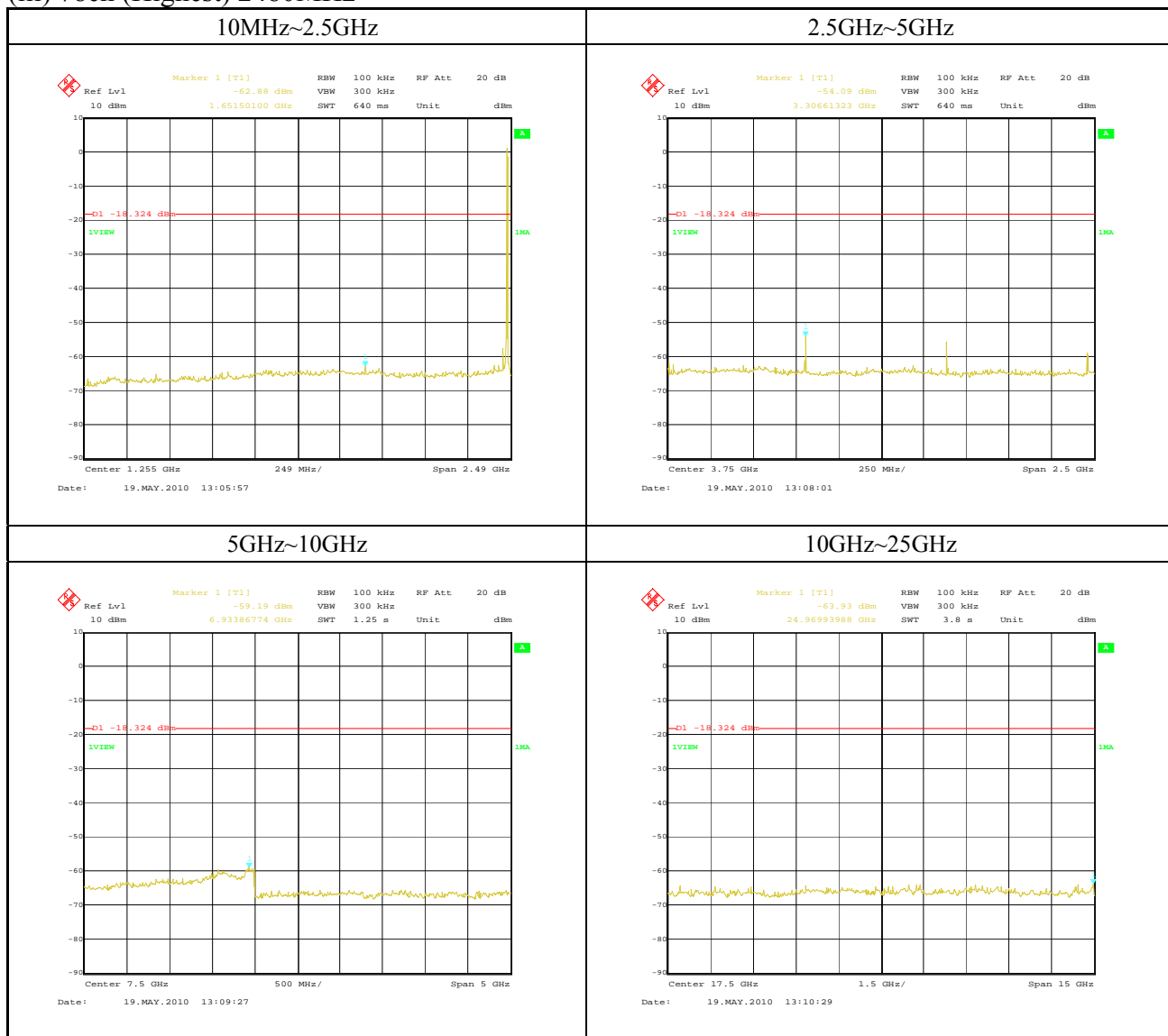

13 Radiated Emission

13.1 Test Setup

The test setup was made according to ANSI STD C63.4: 2003 clause 8 on the 10m semi-anechoic chamber, which allows a 3 or 1m distance measurement.

EUT was placed on non-conductive table (foam polystyrene).

The height of this table was 0.8m.

The measurement has been conducted with both horizontal and vertical antenna polarization.

For above 1GHz, the receiving antenna is fixed in the height that EUT is in the illumination area of the 3dB beamwidth of the antenna.

The turntable has been fully rotated. The highest radiation of the equipment has been recorded.

For further description of the configuration refer to separate document named "Test Setup Photos (10008FC)".

Distance between equipment and antenna : 3m (30MHz to 18GHz)
1m (18GHz to 25GHz)

Test Receiver Setting:

30~1000MHz:

Detector Mode	Quasi-Peak
Bandwidth	120kHz

Spectrum Analyzer Setting:

1~25GHz:

Detector Mode	Peak and Average
Bandwidth	Peak: RBW: 1MHz, VBW: 1MHz
	Average: RBW: 1MHz, VBW: 10Hz

13.2 Radiated Emission Calculation

The field strength is calculated by adding the Antenna Factor and Cable Loss, and subtracting the Amplifier Gain (if any) from the measured reading.

The basic equation with a sample calculation is as follows:

$$c.f. = AF + CF + AL - AG - DF$$

$$RE = RA + c.f.$$

Where

c.f.	:	Correction Factor [dB (1/m)]
RE	:	Radiated Emission (Emission Level - Result) [dB (uV/m)]
RA	:	Receiver Amplitude (Reading Level) [dBuV]
AF	:	Antenna Factor [dB (1/m)]
CF	:	Cable Attenuation Loss [dB]
AG	:	Amplifier Gain [dB]
AL	:	Attenuator Loss [dB]
DF	:	Distance Factor
		Distance between equipment and antenna: 3m = 0 [dB]
		Distance between equipment and antenna: 1m = 9.5 [dB]

Assume a receiver reading of 36.5dBuV is obtained.

The Correction Factor of -2.0dB/m is added, giving a Radiated Emission of 34.5dBuV/m.

The 34.5dBuV/m value was mathematically converted to its corresponding level in uV/m.

$$RE = 36.5 + (-2.0) = 34.5\text{dBuV/m}$$

$$\text{Level in uV/m} = \text{Common Antilogarithm: } 10^{(34.5 / 20)} = 53.1\text{uV/m}$$

13.3 Test Results

Product	: Bluetooth Module	Model	: BTU-3586
Serial No.	: 47	Test Standard	: FCC Part15 Subpart C §15.247(d)
Power Supply	: DC 3.3V	Temp. / Humid.	: Below 1GHz 20.1 degree C / 45.8%
Operator	: Masashi Tsukui		: Above 1GHz 19.3 degree C / 41.7%
Remark	: Transmitting Mode		
	: GFSK Modulation		

Radiated Emission: Lch (2402MHz)

Below 1GHz

Frequency [MHz]	Pol. [H / V]	Reading [dB(uV)]			Factor [dB/m]	Level [dB(uV/m)]			Limit [dB(uV/m)]	Margin [dB]			Remark
		QP	AV	PK		QP	AV	PK		QP	AV	PK	
231.940	V	34.6			-10.4	24.2			46.0	21.8			*
288.011	H	41.2			-7.4	33.8			46.0	12.2			*

Above 1GHz

Frequency [MHz]	Pol. [H / V]	Reading [dB(uV)]			Factor [dB/m]	Level [dB(uV/m)]			Limit [dB(uV/m)]	Margin [dB]			Remark
		QP	AV	PK		QP	AV	PK		QP	AV	PK	
1602.010	H			53.3	-9.0			44.3	74.0			29.7	
1602.010	H		49.3		-9.0			40.3	54.0			13.7	
1602.070	V			53.3	-9.0			44.3	74.0			29.7	
1602.070	V		48.8		-9.0			39.8	54.0			14.2	
4804.000	H			58.1	1.4			59.5	74.0			14.5	
4804.000	H		50.5		1.4			51.9	54.0			2.1	
4804.000	V			55.1	1.4			56.5	74.0			17.5	
4804.000	V		47.1		1.4			48.5	54.0			5.5	
7206.000	H			44.6	4.8			49.4	74.0			24.6	* Floor Noise
7206.000	H		31.7		4.8			36.5	54.0			17.5	* Floor Noise
9608.000	H			43.7	7.8			51.5	74.0			22.5	* Floor Noise
9608.000	H		31.8		7.8			39.6	54.0			14.4	* Floor Noise
12010.000	H			46.2	8.4			54.6	74.0			19.4	Floor Noise
12010.000	H		33.0		8.4			41.4	54.0			12.6	Floor Noise

Note: * = Out of Restricted Band.

This frequency is out of the restricted bands, so radiated emission limits specified in Section 15.209 does not apply.

15.247(d):

Radiated emissions which fall in the restricted bands, as defined in Section 15.205(a), must also comply with the radiated emission limits specified in Section 15.209(a) (see Section 15.205(c)).

Radiated Emission: Mch (2441MHz)

Below 1GHz

Frequency [MHz]	Pol. [H / V]	Reading [dB(uV)]			Factor [dB/m]	Level [dB(uV/m)]			Limit [dB(uV/m)]	Margin [dB]			Remark
		QP	AV	PK		QP	AV	PK		QP	AV	PK	
231.942	V	32.0			-10.4	21.6			46.0	24.4			*
288.012	H	40.7			-7.4	33.3			46.0	12.7			*

Above 1GHz

Frequency [MHz]	Pol. [H / V]	Reading [dB(uV)]			Factor [dB/m]	Level [dB(uV/m)]			Limit [dB(uV/m)]	Margin [dB]			Remark
		QP	AV	PK		QP	AV	PK		QP	AV	PK	
1626.625	V			55.7	-8.8			46.9	74.0			27.1	*
1626.625	V		52.7		-8.8		43.9		54.0		10.1		*
1626.720	H			55.4	-8.8			46.6	74.0			27.4	*
1626.720	H		52.4		-8.8		43.6		54.0		10.4		*
4882.000	H			52.1	1.6			53.7	74.0			20.3	
4882.000	H		44.4		1.6		46.0		54.0		8.0		
4882.000	V			49.7	1.6			51.3	74.0			22.7	
4882.000	V		33.9		1.6		35.5		54.0		18.5		
7323.000	H			44.9	4.9			49.8	74.0			24.2	Floor Noise
7323.000	H		31.6		4.9		36.5		54.0		17.5		Floor Noise
9764.000	H			43.2	7.8			51.0	74.0			23.0	* Floor Noise
9764.000	H		31.3		7.8		39.1		54.0		14.9		* Floor Noise
12205.000	H			44.5	8.6			53.1	74.0			20.9	Floor Noise
12205.000	H		32.2		8.6		40.8		54.0		13.2		Floor Noise

Note: * = Out of Restricted Band.

This frequency is out of the restricted bands, so radiated emission limits specified in Section 15.209 does not apply.

15.247(d):

Radiated emissions which fall in the restricted bands, as defined in Section 15.205(a), must also comply with the radiated emission limits specified in Section 15.209(a) (see Section 15.205(c)).

Radiated Emission: Hch (2480MHz)

Below 1GHz

Frequency [MHz]	Pol. [H / V]	Reading [dB(uV)] QP / AV / PK			Factor [dB/m]	Level [dB(uV/m)] QP / AV / PK			Limit [dB(uV/m)]	Margin [dB] QP / AV / PK			Remark
231.922	V	32.2			-10.4	21.8			46.0	24.2			*
288.018	H	41.2			-7.4	33.8			46.0	12.2			*

Above 1GHz

Frequency [MHz]	Pol. [H / V]	Reading [dB(uV)] QP / AV / PK			Factor [dB/m]	Level [dB(uV/m)] QP / AV / PK			Limit [dB(uV/m)]	Margin [dB] QP / AV / PK			Remark
1652.515	H			56.8	-8.7			48.1	74.0			25.9	*
1652.515	H		54.2		-8.7		45.5		54.0		8.5		*
1652.715	V			56.9	-8.7			48.2	74.0			25.8	*
1652.715	V		54.8		-8.7		46.1		54.0		7.9		*
4960.000	H			52.2	1.8			54.0	74.0			20.0	
4960.000	H		43.4		1.8		45.2		54.0		8.8		
4960.000	V			50.8	1.8			52.6	74.0			21.4	
4960.000	V		38.1		1.8		39.9		54.0		14.1		
7440.000	H			46.0	4.9			50.9	74.0			23.1	Floor Noise
7440.000	H		32.6		4.9		37.5		54.0		16.5		Floor Noise
9920.000	H			45.1	7.6			52.7	74.0			21.3	* Floor Noise
9920.000	H		31.9		7.6		39.5		54.0		14.5		* Floor Noise
12400.000	H			45.6	8.3			53.9	74.0			20.1	Floor Noise
12400.000	H		32.6		8.3		40.9		54.0		13.1		Floor Noise

Note: * = Out of Restricted Band.

This frequency is out of the restricted bands, so radiated emission limits specified in Section 15.209 does not apply.

15.247(d):

Radiated emissions which fall in the restricted bands, as defined in Section 15.205(a), must also comply with the radiated emission limits specified in Section 15.209(a) (see Section 15.205(c)).

Product	: Bluetooth Module	Model	: BTU-3586
Serial No.	: 47	Test Standard	: FCC Part15 Subpart C §15.247(d)
Power Supply	: DC 3.3V	Temp. / Humid.	: Below 1GHz 22.5 degree C / 42.1%
Operator	: Masashi Tsukui		: Above 1GHz 19.3 degree C / 41.7%
Remark	: Transmitting Mode		
	: $\pi/4$ -DQPSK Modulation		

Radiated Emission: Lch (2402MHz)

Below 1GHz

Frequency [MHz]	Pol. [H / V]	Reading [dB(uV)] QP / AV / PK			Factor [dB/m]	Level [dB(uV/m)] QP / AV / PK			Limit [dB(uV/m)]	Margin [dB] QP / AV / PK			Remark
176.025	H	47.0			-9.8	37.2			43.5	6.3			*
232.022	V	44.7			-10.4	34.3			46.0	11.7			*
296.031	H	46.2			-2.5	43.7			46.0	2.3			*

Above 1GHz

Frequency [MHz]	Pol. [H / V]	Reading [dB(uV)] QP / AV / PK			Factor [dB/m]	Level [dB(uV/m)] QP / AV / PK			Limit [dB(uV/m)]	Margin [dB] QP / AV / PK			Remark
1601.958	V			54.1	-9.0			45.1	74.0			28.9	
1601.958	V	49.8			-9.0	40.8			54.0		13.2		
1602.158	H			53.4	-9.0			44.4	74.0			29.6	
1602.158	H	48.3			-9.0	39.3			54.0		14.7		
4804.000	H			58.6	1.4			60.0	74.0			14.0	
4804.000	H	48.0			1.4	49.4			54.0		4.6		
4804.000	V			55.9	1.4			57.3	74.0			16.7	
4804.000	V	46.1			1.4	47.5			54.0		6.5		
7206.000	H			44.6	4.8			49.4	74.0			24.6	* Floor Noise
7206.000	H	31.7			4.8	36.5			54.0		17.5		* Floor Noise
9608.000	H			43.7	7.8			51.5	74.0			22.5	* Floor Noise
9608.000	H	31.8			7.8	39.6			54.0		14.4		* Floor Noise
12010.000	H			46.2	8.4			54.6	74.0			19.4	Floor Noise
12010.000	H	33.0			8.4	41.4			54.0		12.6		Floor Noise

Note: * = Out of Restricted Band.

This frequency is out of the restricted bands, so radiated emission limits specified in Section 15.209 does not apply.

15.247(d):

Radiated emissions which fall in the restricted bands, as defined in Section 15.205(a), must also comply with the radiated emission limits specified in Section 15.209(a) (see Section 15.205(c)).

Radiated Emission: Mch (2441MHz)

Below 1GHz

Frequency [MHz]	Pol. [H / V]	Reading [dB(uV)]			Factor [dB/m]	Level [dB(uV/m)]			Limit [dB(uV/m)]	Margin [dB]			Remark
		QP	AV	PK		QP	AV	PK		QP	AV	PK	
176.013	H	47.2			-9.8	37.4			43.5	6.1			*
232.021	V	44.2			-10.4	33.8			46.0	12.2			*
296.027	H	46.0			-2.5	43.5			46.0	2.5			*

Above 1GHz

Frequency [MHz]	Pol. [H / V]	Reading [dB(uV)]			Factor [dB/m]	Level [dB(uV/m)]			Limit [dB(uV/m)]	Margin [dB]			Remark
		QP	AV	PK		QP	AV	PK		QP	AV	PK	
1626.535	V			55.4	-8.8			46.6	74.0			27.4	*
1626.535	V		53.2		-8.8		44.4		54.0		9.6		*
1626.685	H			56.0	-8.8			47.2	74.0			26.8	*
1626.685	H		52.3		-8.8		43.5		54.0		10.5		*
4882.000	H			53.8	1.6			55.4	74.0			18.6	
4882.000	H		43.5		1.6		45.1		54.0		8.9		
4882.000	V			51.2	1.6			52.8	74.0			21.2	
4882.000	V		34.5		1.6		36.1		54.0		17.9		
7323.000	H			44.9	4.9			49.8	74.0			24.2	Floor Noise
7323.000	H		31.6		4.9		36.5		54.0		17.5		Floor Noise
9764.000	H			43.2	7.8			51.0	74.0			23.0	* Floor Noise
9764.000	H		31.3		7.8		39.1		54.0		14.9		* Floor Noise
12205.000	H			44.5	8.6			53.1	74.0			20.9	Floor Noise
12205.000	H		32.2		8.6		40.8		54.0		13.2		Floor Noise

Note: * = Out of Restricted Band.

This frequency is out of the restricted bands, so radiated emission limits specified in Section 15.209 does not apply.

15.247(d):

Radiated emissions which fall in the restricted bands, as defined in Section 15.205(a), must also comply with the radiated emission limits specified in Section 15.209(a) (see Section 15.205(c)).

Radiated Emission: Hch (2480MHz)

Below 1GHz

Frequency [MHz]	Pol. [H / V]	Reading [dB(uV)]			Factor [dB/m]	Level [dB(uV/m)]			Limit [dB(uV/m)]	Margin [dB]			Remark
		QP	AV	PK		QP	AV	PK		QP	AV	PK	
176.021	H	47.0			-8.5	38.5			43.5	5.0			*
232.021	V	44.2			-10.4	33.8			46.0	12.2			*
296.021	H	46.1			-2.5	43.6			46.0	2.4			*

Above 1GHz

Frequency [MHz]	Pol. [H / V]	Reading [dB(uV)]			Factor [dB/m]	Level [dB(uV/m)]			Limit [dB(uV/m)]	Margin [dB]			Remark
		QP	AV	PK		QP	AV	PK		QP	AV	PK	
1652.585	V			57.1	-8.7			48.4	74.0			25.6	*
1652.585	V		55.0		-8.7		46.3		54.0		7.7		*
1653.040	H			55.3	-8.7			46.6	74.0			27.4	*
1653.040	H		54.4		-8.7		45.7		54.0		8.3		*
4960.000	H			53.5	1.8			55.3	74.0			18.7	
4960.000	H		41.6		1.8		43.4		54.0		10.6		
4960.000	V			52.7	1.8			54.5	74.0			19.5	
4960.000	V		37.7		1.8		39.5		54.0		14.5		
7440.000	H			46.0	4.9			50.9	74.0			23.1	Floor Noise
7440.000	H		32.6		4.9		37.5		54.0		16.5		Floor Noise
9920.000	H			45.1	7.6			52.7	74.0			21.3	* Floor Noise
9920.000	H		31.9		7.6		39.5		54.0		14.5		* Floor Noise
12400.000	H			45.6	8.3			53.9	74.0			20.1	Floor Noise
12400.000	H		32.6		8.3		40.9		54.0		13.1		Floor Noise

Note: * = Out of Restricted Band.

This frequency is out of the restricted bands, so radiated emission limits specified in Section 15.209 does not apply.

15.247(d):

Radiated emissions which fall in the restricted bands, as defined in Section 15.205(a), must also comply with the radiated emission limits specified in Section 15.209(a) (see Section 15.205(c)).

Product	: Bluetooth Module	Model	: BTU-3586
Serial No.	: 47	Test Standard	: FCC Part15 Subpart C §15.247(d)
Power Supply	: DC 3.3V	Temp. / Humid.	: Below 1GHz 22.5 degree C / 42.1% Above 1GHz 19.3 degree C / 41.7%
Operator	: Masashi Tsukui		
Remark	: Transmitting Mode 8DPSK Modulation		

Radiated Emission: Lch (2402MHz)

Below 1GHz

Frequency [MHz]	Pol. [H / V]	Reading [dB(uV)] QP / AV / PK			Factor [dB/m]	Level [dB(uV/m)] QP / AV / PK			Limit [dB(uV/m)]	Margin [dB] QP / AV / PK			Remark
143.990	V	39.3			-9.7	29.6			43.5	13.9			*
176.017	H	46.2			-9.8	36.4			43.5	7.1			*
232.015	V	43.1			-10.4	32.7			46.0	13.3			*
296.017	H	44.9			-2.5	42.4			46.0	3.6			*

Above 1GHz

Frequency [MHz]	Pol. [H / V]	Reading [dB(uV)] QP / AV / PK			Factor [dB/m]	Level [dB(uV/m)] QP / AV / PK			Limit [dB(uV/m)]	Margin [dB] QP / AV / PK			Remark
1602.018	H			54.2	-9.0			45.2	74.0			28.8	
1602.018	H			50.8	-9.0			41.8	54.0			12.2	
1602.113	V			53.9	-9.0			44.9	74.0			29.1	
1602.113	V			49.9	-9.0			40.9	54.0			13.1	
4804.000	H			59.1	1.4			60.5	74.0			13.5	
4804.000	H			48.6	1.4			50.0	54.0			4.0	
4804.000	V			57.3	1.4			58.7	74.0			15.3	
4804.000	V			47.0	1.4			48.4	54.0			5.6	
7206.000	H			44.6	4.8			49.4	74.0			24.6	* Floor Noise
7206.000	H			31.7	4.8			36.5	54.0			17.5	* Floor Noise
9608.000	H			43.7	7.8			51.5	74.0			22.5	* Floor Noise
9608.000	H			31.8	7.8			39.6	54.0			14.4	* Floor Noise
12010.000	H			46.2	8.4			54.6	74.0			19.4	Floor Noise
12010.000	H			33.0	8.4			41.4	54.0			12.6	Floor Noise

Note: * = Out of Restricted Band.

This frequency is out of the restricted bands, so radiated emission limits specified in Section 15.209 does not apply.

15.247(d):

Radiated emissions which fall in the restricted bands, as defined in Section 15.205(a), must also comply with the radiated emission limits specified in Section 15.209(a) (see Section 15.205(c)).

Radiated Emission: Mch (2441MHz)

Below 1GHz

Frequency [MHz]	Pol. [H / V]	Reading [dB(uV)]			Factor [dB/m]	Level [dB(uV/m)]			Limit [dB(uV/m)]	Margin [dB]			Remark
		QP	AV	PK		QP	AV	PK		QP	AV	PK	
176.014	H	46.2			-9.8	36.4			43.5	7.1			*
232.012	V	43.1			-10.4	32.7			46.0	13.3			*
296.011	H	44.7			-2.5	42.2			46.0	3.8			*

Above 1GHz

Frequency [MHz]	Pol. [H / V]	Reading [dB(uV)]			Factor [dB/m]	Level [dB(uV/m)]			Limit [dB(uV/m)]	Margin [dB]			Remark
		QP	AV	PK		QP	AV	PK		QP	AV	PK	
1626.620	H			55.8	-8.8			47.0	74.0			27.0	*
1626.620	H		52.5		-8.8		43.7		54.0		10.3		*
1626.660	V			56.0	-8.8			47.2	74.0			26.8	*
1626.660	V		53.0		-8.8		44.2		54.0		9.8		*
4882.000	H			54.2	1.6			55.8	74.0			18.2	
4882.000	H		43.7		1.6		45.3		54.0		8.7		
4882.000	V			51.5	1.6			53.1	74.0			20.9	
4882.000	V		37.1		1.6		38.7		54.0		15.3		
7323.000	H			44.9	4.9			49.8	74.0			24.2	Floor Noise
7323.000	H		31.6		4.9		36.5		54.0		17.5		Floor Noise
9764.000	H			43.2	7.8			51.0	74.0			23.0	* Floor Noise
9764.000	H		31.3		7.8		39.1		54.0		14.9		* Floor Noise
12205.000	H			44.5	8.6			53.1	74.0			20.9	Floor Noise
12205.000	H		32.2		8.6		40.8		54.0		13.2		Floor Noise

Note: * = Out of Restricted Band.

This frequency is out of the restricted bands, so radiated emission limits specified in Section 15.209 does not apply.

15.247(d):

Radiated emissions which fall in the restricted bands, as defined in Section 15.205(a), must also comply with the radiated emission limits specified in Section 15.209(a) (see Section 15.205(c)).

Radiated Emission: Hch (2480MHz)

Below 1GHz

Frequency [MHz]	Pol. [H / V]	Reading [dB(uV)]			Factor [dB/m]	Level [dB(uV/m)]			Limit [dB(uV/m)]	Margin [dB]			Remark
		QP	AV	PK		QP	AV	PK		QP	AV	PK	
176.022	H	46.3			-9.8	36.5			43.5	7.0			*
232.014	V	43.9			-10.4	33.5			46.0	12.5			*
296.016	H	45.2			-2.5	42.7			46.0	3.3			*

Above 1GHz

Frequency [MHz]	Pol. [H / V]	Reading [dB(uV)]			Factor [dB/m]	Level [dB(uV/m)]			Limit [dB(uV/m)]	Margin [dB]			Remark
		QP	AV	PK		QP	AV	PK		QP	AV	PK	
1652.510	V			55.7	-8.7			47.0	74.0			27.0	*
1652.510	V		52.9		-8.7		44.2		54.0		9.8		*
1652.545	H			56.5	-8.7			47.8	74.0			26.2	*
1652.545	H		53.9		-8.7		45.2		54.0		8.8		*
4960.000	H			53.8	1.8			55.6	74.0			18.4	
4960.000	H		42.5		1.8		44.3		54.0		9.7		
4960.000	V			52.0	1.8			53.8	74.0			20.2	
4960.000	V		36.6		1.8		38.4		54.0		15.6		
7440.000	H			46.0	4.9			50.9	74.0			23.1	Floor Noise
7440.000	H		32.6		4.9		37.5		54.0		16.5		Floor Noise
9920.000	H			45.1	7.6			52.7	74.0			21.3	* Floor Noise
9920.000	H		31.9		7.6		39.5		54.0		14.5		* Floor Noise
12400.000	H			45.6	8.3			53.9	74.0			20.1	Floor Noise
12400.000	H		32.6		8.3		40.9		54.0		13.1		Floor Noise

Note: * = Out of Restricted Band.

This frequency is out of the restricted bands, so radiated emission limits specified in Section 15.209 does not apply.

15.247(d):

Radiated emissions which fall in the restricted bands, as defined in Section 15.205(a), must also comply with the radiated emission limits specified in Section 15.209(a) (see Section 15.205(c)).

14 Photos of Tested EUT and Test Setup

Setup photo with EUT has been submitted as separate document named “Test Setup Photos (10008FC)”.

Appendix 1: AFH-Hopping Sequence

AFH-Hopping Sequence is provided for in the Bluetooth Spec 1.2. Here is an outline below.

1. In the case of 79Hopping

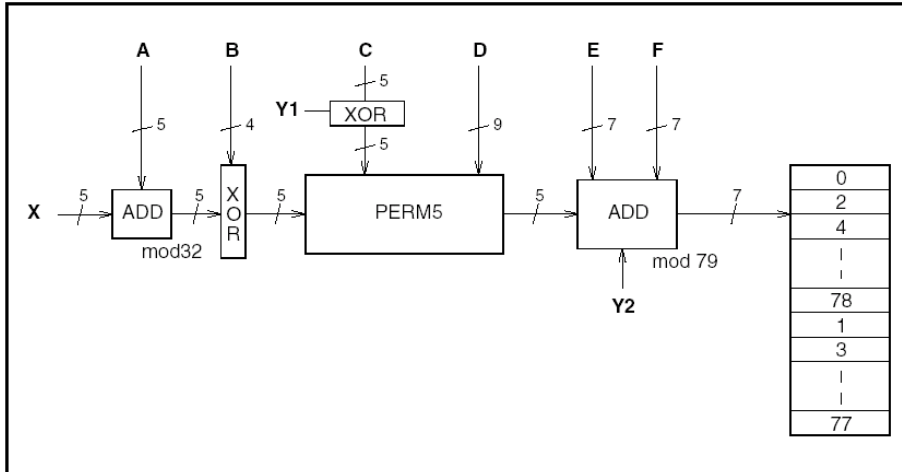

Due to the above flow, 32 hops are made into 5 ways. Then, the sign of the sign head 160 is formed. The remainder that is worked out by dividing with 79 is assigned to Hopping Channel.

Each parameter of the above figure uses the value calculated from the Bluetooth clock and the Bluetooth address, which are shown in the next page.

2. In the case of AFH-Hopping

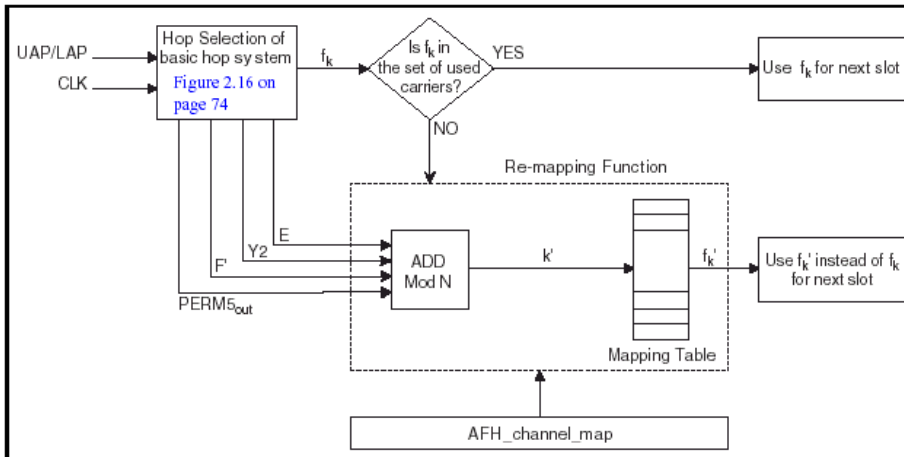

Also in the case of AFH, the fundamental sign adopt the sign head 160 that is the same as the case of 79Hopping. Hopping Pattern uses the value that is worked out by dividing with the number of AFH-Channel's. Then, available Hopping becomes even as well as 79Hopping.

The selection of the communication Channel is done by the communication error rate and the receiving signal strength. Frequency is determined by pairing the channel and the value, which is divided by the number of AFH-Channel one-to-one.

It is decided in the specifications that Communication Channel has to have "20Channels" at least. However, if the number of communication Channel is controlled to be under 20 back to 79Channel-Hopping, and select the communication Channel again.

3. The parameter list which decides Hopping-Pattern

	Page scan / Interlaced Page Scan / Inquiry scan / Interlaced Inquiry Scan	Page/Inquiry	Master/Slave page response and Inquiry response	Connection state
X	$CLKN_{16-12} /$ $(CLKN_{16-12} + 16) \bmod 32 /$ $Xir_{4-0} /$ $Xir_{4-0} + 16) \bmod 32$	Xp_{4-0} / Xi_{4-0}	$Xprm_{4-0} /$ $Xprs_{4-0} /$ Xir_{4-0}	CLK_{6-2}
Y1	0	$CLKE_1 / CLK_{N1}$	$CLKE_1 / CLK_{N1} / 1$	CLK_1
Y2	0	$32 \times CLKE_1 /$ $32 \times CLK_{N1}$	$32 \times CLKE_1 /$ $32 \times CLK_{N1} /$ 32×1	$32 \times CLK_1$
A	A_{27-23}	A_{27-23}	A_{27-23}	$A_{27-23} \oplus CLK_{25-21}$
B	A_{22-19}	A_{22-19}	A_{22-19}	A_{22-19}
C	$A_{8,6,4,2,0}$	$A_{8,6,4,2,0}$	$A_{8,6,4,2,0}$	$A_{8,6,4,2,0} \oplus CLK_{20-16}$
D	A_{18-10}	A_{18-10}	A_{18-10}	$A_{18-10} \oplus CLK_{15-7}$
E	$A_{13,11,9,7,5,3,1}$	$A_{13,11,9,7,5,3,1}$	$A_{13,11,9,7,5,3,1}$	$A_{13,11,9,7,5,3,1}$
F	0	0	0	$16 \times CLK_{27-7} \bmod 79$
F'	n/a	n/a	n/a	$16 \times CLK_{27-7} \bmod N$

Appendix 2: Certificate of Accreditation

**United States Department of Commerce
National Institute of Standards and Technology**

NVLAP[®]

Certificate of Accreditation to ISO/IEC 17025:2005

NVLAP LAB CODE: 200607-0

Taiyo Yuden Co., Ltd. EMC Center
Takasaki-shi Gunma 370-3347
JAPAN

*is accredited by the National Voluntary Laboratory Accreditation Program for specific services,
listed on the Scope of Accreditation, for:*

ELECTROMAGNETIC COMPATIBILITY AND TELECOMMUNICATIONS

*This laboratory is accredited in accordance with the recognized International Standard ISO/IEC 17025:2005.
This accreditation demonstrates technical competence for a defined scope and the operation of a laboratory quality
management system (refer to joint ISO-ILAC-IAF Communique dated January 2009).*

2009-10-01 through 2010-09-30
Effective dates



Dolly S. Bruce
For the National Institute of Standards and Technology

NVLAP-01C (REV. 2009-01-28)

Appendix 3: Test Instruments

1. Conducted RF Test via Antenna Terminal

Instrument	Manufacturer	Model No.	Serial No.	Calibration Date (Interval: 1 year)	
Spectrum Analyzer	Rohde & Schwarz	FSIQ26	840061/0004	22 February 2010	●
	Agilent Technologies	E4446A	US42070181	22 October 2009	○
Power Meter	Agilent Technologies	N1911A	MY45100612	19 February 2010	○
Power Sensor	Agilent Technologies	N1922A	MY45240439	19 February 2010	○
RF Cable	SUHNER	SUCOFLEX 104	RF2-2	1 July 2009	●
		SUCOFLEX 104E	RF3-3	1 July 2009	○
Power Divider	Aeroflex / Inmet	6005-03	RF-8	1 July 2009	○
Multi Meter	Advantest	R6451A	67840312	7 December 2009	●
	Agilent Technologies	34401A	MY41038383	8 July 2009	○
Hygro Thermograph	SEKONIC	ST-200	HD01-000797	7 May 2010	●

Note:

- : Applied by measurement.
- : Not applied by measurement.

2. Radiated Emission Test

Instrument	Manufacturer	Model No.	Serial No.	Calibration Date (Interval: 1 year)		
10m Anechoic Chamber	TDK Co., Ltd.	DA-06912	-	2 February 2010	●	
EMI Test Receiver	Rohde & Schwarz	ESCS 30	100148	21 July 2009	●	
Spectrum Analyzer	Agilent Technologies	E4407B	MY44221019	29 April 2010	●	
		E4446A	US42070181	22 October 2009	●	
Amplifier	Agilent Technologies	83017A	3950M00169	30 July 2009	●	
		8447D	2944A06812		●	
RF Selector	TOYO Corporation	NS4900	0302-010		●	
Tunable Filter	TOYO Corporation	NF-49BT	No.1		○	
RF Filter	Microtronics	BRM50702-01	020		○	
RF Cable	SUHNER	RG214	RG1		-	●
			RG3			●
			RG5	●		
			RG7	●		
			RG8	●		
	HP	HP8120-4782	163 9232	30 July 2009		●
	SUHNER	SUCOFLEX 106	SU1			●
		SUCOFLEX 103	SU5		●	
HP	85381C	No.3	○			
Attenuator	KYORITSU	KPD-602	220142	●		
Antenna	Schwarzbeck	BBA9106	No.3	16 December 2009	○	
		UHALP9108-A	0160		○	
		VULB9160	3179		●	
		VHA9103	No.3 (+D3-1, 2)		●	
		UHA9105	No.3		○	
	EMCO	3115	9403-4232	3 February 2010	●	
		3116	9311-2227		●	
Multi Meter	Agilent Technologies	34401A	MY41038383	8 July 2009	●	
Hygro Thermograph	SEKONIC	ST-50	HE01-00511	2 March 2010	●	
Software	TOYO Corporation	EP5/RE Ver.3.7.0	0208086	-	●	

Note:

- : Applied by measurement.
- : Not applied by measurement.