



# TEST REPORT

For GFSK



**Report No.** ..... : **CHTW24070001**      Report Verification:

**Project No.**..... : **SHT2406017001W**

**FCC ID**..... : **SIP-7587-T**

**Applicant's name**..... : **MegaGain International Ltd.**

**Address**..... : Rm 904-905, Greenfield Tower, Concordia Plaza,1 Science Museum Road, T.S.T. East. Kowloon. HongKong

**Product Name** ..... : **TAF ALIEN**

**Trade Mark** ..... : -

**Model No.** ..... : 2401-DW13054(7587-T)

**Listed Model(s)** ..... : -

**Standard** ..... : **FCC CFR Title 47 Part 15 Subpart C § 15.247**

**Date of receipt of test sample**..... : Jun.19, 2024

**Date of testing**..... : Jun.19, 2024 - Jun.28, 2024

**Date of issue**..... : Jul.01, 2024

**Result**..... : **PASS**

**Compiled by**  
 ( Position+Printed name+Signature): File administrators Kiki Kong 

**Supervised by**  
 (Position+Printed name+Signature): Project Engineer Kiki Kong 

**Approved by**  
 (Position+Printed name+Signature): RF Manager Xu yang 

**Testing Laboratory Name** ..... : **Shenzhen Huatongwei International Inspection Co., Ltd.**

**Address**..... : Building 7, Baiwang Idea Factory, No.1051, Songbai Road, Yangguang Community, Xili Subdistrict, Nanshan District, Shenzhen, Guangdong, China

**Shenzhen Huatongwei International Inspection Co., Ltd. All rights reserved.**

This publication may be reproduced in whole or in part for non-commercial purposes as long as the Shenzhen Huatongwei International Inspection Co., Ltd. is acknowledged as copyright owner and source of the material. Shenzhen Huatongwei International Inspection Co., Ltd. takes no responsibility for and will not assume liability for damages resulting from the reader's interpretation of the reproduced material due to its placement and context.

The test report merely correspond to the test sample.

## Contents

<b>1.</b>	<b>TEST STANDARDS AND REPORT VERSION</b>	<b>3</b>
1.1.	Test Standards	3
1.2.	Report version	3
<b>2.</b>	<b>TEST DESCRIPTION</b>	<b>4</b>
<b>3.</b>	<b>SUMMARY</b>	<b>5</b>
3.1.	Client Information	5
3.2.	Product Description	5
3.3.	Radio Specification Description	5
3.4.	Testing Laboratory Information	6
<b>4.</b>	<b>TEST CONFIGURATION</b>	<b>7</b>
4.1.	Test frequency list	7
4.2.	Descriptions of Test mode	7
4.3.	Test sample information	7
4.4.	Support unit used in test configuration and system	8
4.5.	Testing environmental condition	8
4.6.	Statement of the measurement uncertainty	8
4.7.	Equipment Used during the Test	9
<b>5.</b>	<b>TEST CONDITIONS AND RESULTS</b>	<b>11</b>
5.1.	Antenna Requirement	11
5.2.	AC Conducted Emission	12
5.3.	Peak Output Power	13
5.4.	Power Spectral Density	14
5.5.	6dB bandwidth	15
5.6.	99% Occupied Bandwidth	16
5.7.	Duty Cycle	17
5.8.	Conducted Band edge and Spurious Emission	18
5.9.	Radiated Band edge Emission	19
5.10.	Radiated Spurious Emission	21
<b>6.</b>	<b>TEST SETUP PHOTOS</b>	<b>26</b>
<b>7.</b>	<b>EXTERNAL AND INTERNAL PHOTOS</b>	<b>28</b>
7.1.	External Photos	28
7.2.	Internal Photos	30
<b>8.</b>	<b>APPENDIX REPORT</b>	<b>32</b>

# 1. TEST STANDARDS AND REPORT VERSION

## 1.1. Test Standards

The tests were performed according to following standards:

- [FCC CFR Title 47 Part 15 Subpart C § 15.247](#): Operation within the bands 902-928 MHz, 2400-2483.5 MHz, and 5725-5850 MHz
- [ANSI C63.10:2020](#): American National Standard for Testing Unlicensed Wireless Devices
- [KDB 558074 D01 15.247 Meas Guidance v05r02](#): Guidance for Compliance Measurements on Digital Transmission System, Frequency Hopping Spread Spectrum System, and Hybrid System Devices Operating under Section 15.247 of The FCC Rules

## 1.2. Report version

Revision No.	Date of issue	Description
N/A	2024-07-01	Original

## 2. TEST DESCRIPTION

Report clause	Test Items	Standard Requirement	Result	Test Engineer
5.1	Antenna Requirement	15.203/15.247(c)	PASS	Chenxin Ling
5.2	AC Conducted Emission	15.207	N/A	N/A
5.3	Peak Output Power	15.247(b)(3)	PASS	Chenxin Ling
5.4	Power Spectral Density	15.247(e)	PASS	Chenxin Ling
5.5	6dB Bandwidth	15.247(a)(2)	PASS	Chenxin Ling
5.6	99% Occupied Bandwidth	-	PASS*1	Chenxin Ling
5.7	Duty cycle	-	PASS*1	Chenxin Ling
5.8	Conducted Band Edge and Spurious Emission	15.247(d)/15.205	PASS	Chenxin Ling
5.9	Radiated Band Edge Emission	15.205/15.209	PASS	Yifan Wang
5.10	Radiated Spurious Emission	15.247(d)/15.205/15.209	PASS	Yifan Wang

Note:

- The measurement uncertainty is not included in the test result.
- \*1: No requirement on standard, only report these test data.
- N/A: Not tested

### 3. SUMMARY

#### 3.1. Client Information

Applicant:	MegaGain International Ltd.
Address:	Rm 904-905, Greenfield Tower, Concordia Plaza,1 Science Museum Road, T.S.T. East. Kowloon. HongKong
Manufacturer:	MegaGain International Ltd.
Address:	Rm 904-905, Greenfield Tower, Concordia Plaza,1 Science Museum Road, T.S.T. East. Kowloon. HongKong
Factory:	JEM Master Tech (Jiangxi) Manufacturing Co., Ltd.
Address:	Leiden industrial Zone, Industrial Park, Xinfeng Country Ganzhou, Jiangxi, China

#### 3.2. Product Description

Main unit information:	
Product Name:	TAF ALIEN
Trade Mark:	-
Model No.:	2401-DW13054(7587-T)
Listed Model(s):	-
Power supply:	DC 4.5V from Battery
Hardware version:	V1
Software version:	V1

#### 3.3. Radio Specification Description

Modulation:	GFSK
Operation frequency:	2420MHz~2462MHz
Channel number:	43
Antenna type:	Monopole Antenna
Antenna gain:	0dBi

### 3.4. Testing Laboratory Information

Laboratory Name	Shenzhen Huatongwei International Inspection Co., Ltd.	
Laboratory Location	Building 7, Baiwang Idea Factory, No.1051, Songbai Road, Yangguang Community, Xili Subdistrict, Nanshan District, Shenzhen, Guangdong, China	
Contact information:	Phone: 86-755-26715499 E-mail: <a href="mailto:cs@szhtw.com.cn">cs@szhtw.com.cn</a> <a href="http://www.szhtw.com.cn">http://www.szhtw.com.cn</a>	
Qualifications	Type	Accreditation Number
	FCC Registration Number	762235
	FCC Designation Number	CN1181

## 4. TEST CONFIGURATION

### 4.1. Test frequency list

According to section 15.31(m), regards to the operating frequency range over 10 MHz, must select three channels which were tested. The Lowest frequency, the middle frequency, and the highest frequency of channel were selected to perform the test, please see the below blue front.

Channel	Frequency (MHz)	Channel	Frequency (MHz)	Channel	Frequency (MHz)	Channel	Frequency (MHz)
00	2420	12	2432	24	2444	36	2456
01	2421	13	2433	25	2445	37	2457
02	2422	14	2434	26	2446	38	2458
03	2423	15	2435	27	2447	39	2459
04	2424	16	2436	28	2448	40	2460
05	2425	17	2437	29	2449	41	2461
06	2426	18	2438	30	2450	42	2462
07	2427	19	2439	31	2451		
08	2428	20	2440	32	2452		
09	2429	21	2441	33	2453		
10	2430	22	2442	34	2454		
11	2431	23	2443	35	2455		

### 4.2. Descriptions of Test mode

For RF test items
The engineering test program was provided and enabled to make EUT continuous transmit.
For Radiated spurious emissions:
The engineering test program was provided and enabled to make EUT continuous transmit. The EUT in each of three orthogonal axis emissions had been tested, but only the worst case (X axis) data Recorded in the report.

### 4.3. Test sample information

Test item	HTW sample no.
RF Conducted test items	Please refer to the description in the appendix report
RF Radiated test items	YPHT24060170001_02
EMI test items	-

Note:

RF Conducted test items: Peak Output Power, Power Spectral Density, 6dB Bandwidth, 99% Occupied Bandwidth, Duty cycle, Conducted Band Edge and Spurious Emission

RF Radiated test items: Radiated Band Edge Emission, Radiated Spurious Emission

EMI test items: AC Conducted Emission

#### 4.4. Support unit used in test configuration and system

The EUT has been associated with peripherals and configuration operated in a manner tended to maximize its emission characteristics in a typical application.

The following peripheral devices and interface cables were connected during the measurement:

Whether support unit is used?			
✓ No			
Item	Equipment	Trade Name	Model No.
1			
2			

#### 4.5. Testing environmental condition

Type	Requirement	Actual
Temperature:	15~35°C	25°C
Relative Humidity:	25~75%	50%
Air Pressure:	860~1060mbar	1000mbar

#### 4.6. Statement of the measurement uncertainty

No.	Test Items	Measurement Uncertainty
1	AC Conducted Emission	3.21dB
2	Peak Output Power	1.07
3	Power Spectral Density	1.07
4	6dB Bandwidth	0.002%
5	99% Occupied Bandwidth	0.002%
6	Duty cycle	-
7	Conducted Band Edge and Spurious Emission	1.68dB
8	Radiated Band Edge Emission	4.54dB for 30MHz-1GHz 5.10dB for above 1GHz
9	Radiated Spurious Emission	4.54dB for 30MHz-1GHz 5.10dB for above 1GHz

This uncertainty represents an expanded uncertainty expressed at approximately the 95% confidence level using a coverage factor of k=1.96.



#### 4.7. Equipment Used during the Test

● RF Conducted test item							
Used	Test Equipment	Manufacturer	Equipment No.	Model No.	Serial No.	Last Cal. Date (YY-MM-DD)	Next Cal. Date (YY-MM-DD)
●	Signal and spectrum Analyzer	R&S	HTWE0242	FSV40	100048	2023/08/22	2024/08/21
●	Signal & Spectrum Analyzer	R&S	HTWE0262	FSW26	103440	2023/08/22	2024/08/21
●	Vector signal generator	R&S	HTWE0244	SMBV100A	260790	2024/5/25	2025/5/24
●	Test software	Tonscend	N/A	JS1120	N/A	N/A	N/A

● Conducted Emission							
Used	Test Equipment	Manufacturer	Equipment No.	Model No.	Serial No.	Last Cal. Date (YY-MM-DD)	Next Cal. Date (YY-MM-DD)
●	EMI Test Receiver	R&S	HTWE0111	ESCI	101247	2023/8/30	2024/8/29
●	Artificial Mains	SCHWARZBECK	HTWE0113	NNLK 8121	573	2023/08/18	2024/08/17
●	Protection Network	SCHWARZBECK	HTWE0567	VTSD9561FN	00899	2023/08/18	2024/08/17
●	ISN	FCC	HTWE0148	FCC-TLISN-T2-02	20371	2023/08/18	2024/08/17
●	ISN	FCC	HTWE0150	FCC-TLISN-T8-02	20375	2023/08/18	2024/08/17
●	Test Software	R&S	N/A	EMC32	N/A	N/A	N/A

● Radiated Emission – 9kHz~30MHz							
Used	Test Equipment	Manufacturer	Equipment No.	Model No.	Serial No.	Last Cal. Date (YY-MM-DD)	Next Cal. Date (YY-MM-DD)
●	Semi-Anechoic Chamber	Albatross projects	HTWE0127	SAC-3m-02	C11121	2023/04/06	2026/04/05
●	EMI Test Receiver	R&S	HTWE0099	ESCI 7	100900	2023/08/22	2024/08/21
●	Loop Antenna	R&S	HTWE0170	HFH2-Z2	100020	2024/04/08	2027/04/07
●	Test Software	R&S	N/A	EMC32	N/A	N/A	N/A

● Radiated Emission - 30MHz~1GHz							
Used	Test Equipment	Manufacturer	Equipment No.	Model No.	Serial No.	Last Cal. Date (YY-MM-DD)	Next Cal. Date (YY-MM-DD)
●	Semi-Anechoic Chamber	Albatross projects	HTWE0127	SAC-3m-02	C11121	2023/4/6	2026/4/5
●	EMI Test Receiver	R&S	HTWE0099	ESCI 7	100900	2023/8/22	2024/8/21
●	Ultra-Broadband Antenna	SCHWARZBEC K	HTWE0119	VULB9163	546	2023/2/22	2026/2/21
●	Pre-Amplifier	SCHWARZBEC K	HTWE0295	BBV 9742	/	2024/5/24	2025/5/23
●	Test Software	R&S	N/A	EMC32	N/A	N/A	N/A

● Radiated emission-Above 1GHz							
Used	Test Equipment	Manufacturer	Equipment No.	Model No.	Serial No.	Last Cal. Date (YY-MM-DD)	Next Cal. Date (YY-MM-DD)
●	Semi-Anechoic Chamber	Albatross projects	HTWE0122	SAC-3m-01	C11121	2023/04/17	2026/04/16
●	Spectrum Analyzer	R&S	HTWE0098	FSP40	100597	2023/08/22	2024/08/21
●	Spectrum Analyzer	R&S	HTWE0385	N9020A	MY54486658	2023/08/22	2024/08/21
●	Horn Antenna	SCHWARZBECK	HTWE0126	BBHA 9120D	1011	2023/02/14	2026/02/13
●	Pre-Amplifier	CD	HTWE0071	PAP-0102	12004	2023/06/15	2024/06/14
●	Broadband Pre-amplifier	SCHWARZBECK	HTWE0551	SCU18F	100855	2024/6/6	2025/6/5
●	Test Software	Audix	N/A	E3	N/A	N/A	N/A

## 5. TEST CONDITIONS AND RESULTS

### 5.1. Antenna Requirement

#### REQUIREMENT

##### **FCC CFR Title 47 Part 15 Subpart C Section 15.203:**

An intentional radiator shall be designed to ensure that no antenna other than that furnished by the responsible party shall be used with the device. The use of a permanently attached antenna or of an antenna that uses a unique coupling to the intentional radiator, the manufacturer may design the unit so that a broken antenna can be replaced by the user, but the use of a standard antenna jack or electrical connector is prohibited.

#### TEST RESULT

**Passed**       **Not Applicable**

The antenna type is a Monopole antenna, please refer to the below antenna photo.

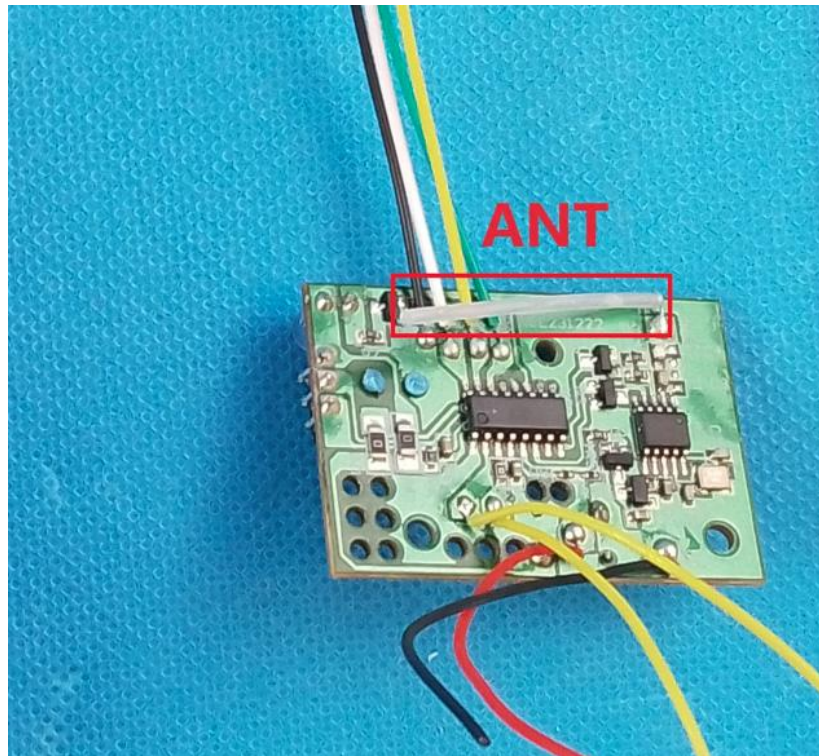

## 5.2. AC Conducted Emission

### LIMIT

#### FCC CFR Title 47 Part 15 Subpart C Section 15.207

Frequency range (MHz)	Limit (dBuV)	
	Quasi-peak	Average
0.15-0.5	66 to 56*	56 to 46*
0.5-5	56	46
5-30	60	50

\* Decreases with the logarithm of the frequency.

### TEST CONFIGURATION

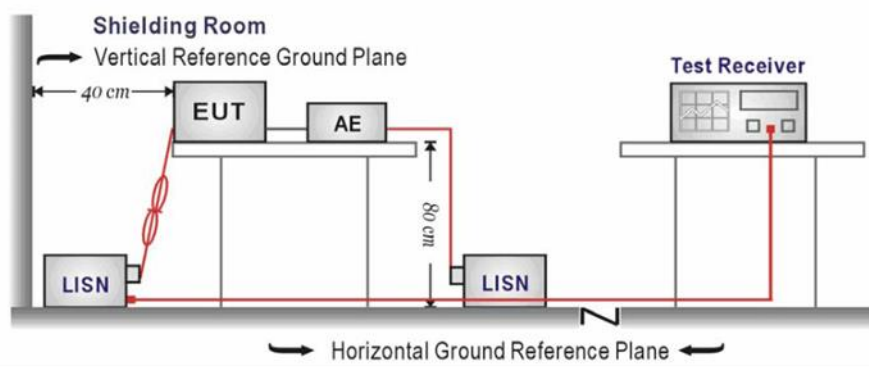

### TEST PROCEDURE

1. The EUT was setup according to ANSI C63.10 requirements.
2. The EUT was placed on a platform of nominal size, 1 m by 1.5 m, raised 80 cm above the conducting ground plane. The vertical conducting plane was located 40 cm to the rear of the EUT. All other surfaces of EUT were at least 80 cm from any other grounded conducting surface.
3. The EUT and simulators are connected to the main power through a line impedances stabilization network (LISN). The LISN provides a 50 ohm /50uH coupling impedance for the measuring equipment.
4. The peripheral devices are also connected to the main power through a LISN. (Please refer to the block diagram of the test setup and photographs)
5. Each current-carrying conductor of the EUT power cord, except the ground (safety) conductor, was individually connected through a LISN to the input power source.
6. The excess length of the power cord between the EUT and the LISN receptacle were folded back and forth at the center of the lead to form a bundle not exceeding 40 cm in length.
7. Conducted emissions were investigated over the frequency range from 0.15MHz to 30MHz using a receiver bandwidth of 9 kHz.
8. During the above scans, the emissions were maximized by cable manipulation.

### TEST MODE

Refer to the clause 4.2

### TEST RESULT

Passed       Not Applicable

NOTE: The power supply method is dry battery power supply

### 5.3. Peak Output Power

#### LIMIT

FCC CFR Title 47 Part 15 Subpart C Section 15.247 (b)(3): 30dBm

#### TEST CONFIGURATION

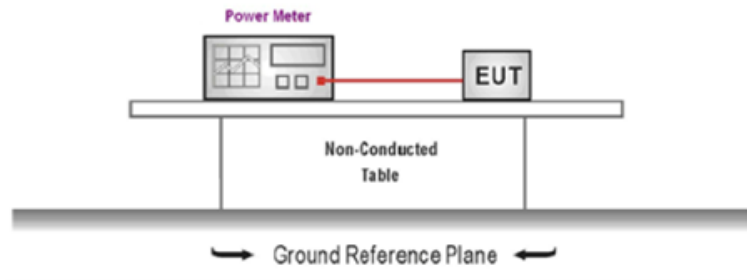

#### TEST PROCEDURE

1. The EUT was tested according to ANSI C63.10 and KDB 558074 D01 requirements.
2. The maximum peak conducted output power may be measured using a broadband peak RF power meter.
3. The power meter shall have a video bandwidth that is greater than or equal to the DTS bandwidth and shall utilize a fast-responding diode detector.
4. Record the measurement data.

#### TEST MODE

Refer to the clause 4.2

#### TEST RESULT

Passed       Not Applicable

#### TEST DATA

Refer to the appendix report

## 5.4. Power Spectral Density

### LIMIT

#### FCC CFR Title 47 Part 15 Subpart C Section 15.247 (e):

For digitally modulated systems, the power spectral density conducted from the intentional radiator to the antenna shall not be greater than 8dBm in any 3 kHz band during any time interval of continuous transmission.

### TEST CONFIGURATION

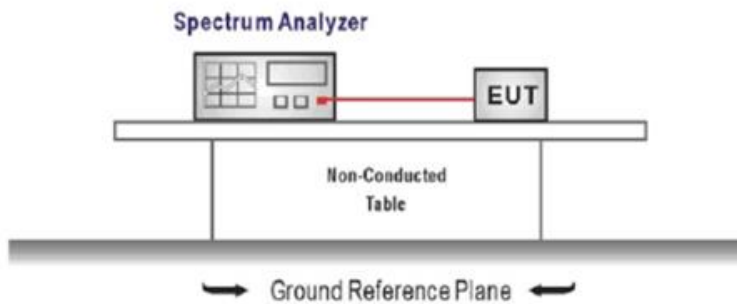

### TEST PROCEDURE

1. Connect the antenna port(s) to the spectrum analyzer input,
2. Configure the spectrum analyzer as shown below:  
Center frequency=DTS channel center frequency  
Span =1.5 times the DTS bandwidth  
RBW = 3 kHz ≤ RBW ≤ 100 kHz, VBW ≥ 3 × RBW  
Sweep time = auto couple  
Detector = peak  
Trace mode = max hold
3. Place the radio in continuous transmit mode, allow the trace to stabilize, view the transmitter wave form on the spectrum analyzer.
4. Use the peak marker function to determine the maximum amplitude level within the RBW.
5. If measured value exceeds limit, reduce RBW (no less than 3 kHz) and repeat.

### TEST MODE

Refer to the clause 4.2

### TEST RESULT

Passed       Not Applicable

### TEST DATA

Refer to the appendix report

## 5.5. 6dB bandwidth

### LIMIT

FCC CFR Title 47 Part 15 Subpart C Section 15.247 (a)(2):

For digital modulation systems, the minimum 6 dB bandwidth shall be at least 500 kHz.

### TEST CONFIGURATION

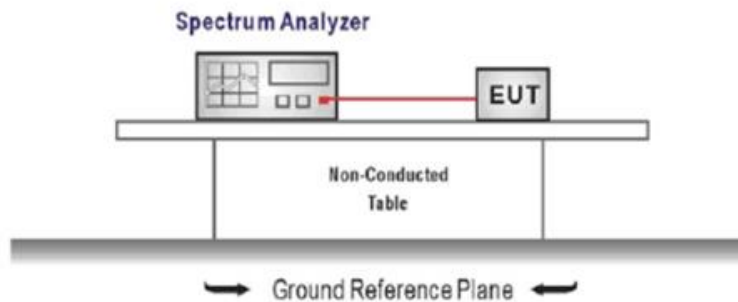

### TEST PROCEDURE

1. Connect the antenna port(s) to the spectrum analyzer input.
2. Configure the spectrum analyzer as shown below (enter all losses between the transmitter output and the spectrum analyzer).  
Center Frequency =DTS channel center frequency  
Span=2 x DTS bandwidth  
RBW = 100 kHz, VBW  $\geq 3 \times$  RBW  
Sweep time= auto couple  
Detector = Peak  
Trace mode = max hold
3. Place the radio in continuous transmit mode, allow the trace to stabilize, view the transmitter waveform on the spectrum analyzer.
4. Measure the maximum width of the emission that is constrained by the frequencies associated with the two outermost amplitude points (upper and lower frequencies) that are attenuated by 6 dB relative to the maximum level measured in the fundamental emission, and record the pertinent measurements.

### TEST MODE

Refer to the clause 4.2

### TEST RESULT

Passed       Not Applicable

### TEST DATA

Refer to the appendix report

## 5.6. 99% Occupied Bandwidth

### LIMIT

N/A

### TEST CONFIGURATION

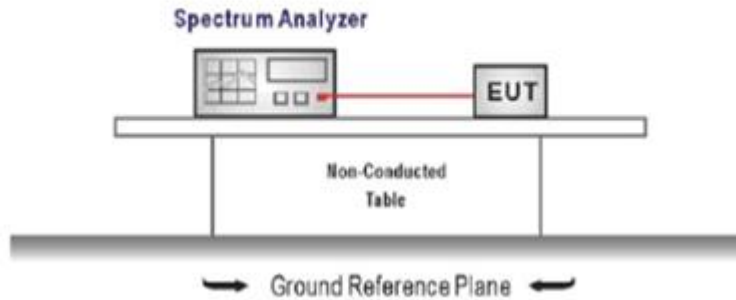

### TEST PROCEDURE

1. Connect the antenna port(s) to the spectrum analyzer input.
2. Configure the spectrum analyzer as shown below (enter all losses between the transmitter output and the spectrum analyzer).  
Center Frequency = channel center frequency  
Span  $\geq 1.5 \times$  OBW  
RBW = 1%~5%OBW  
VBW  $\geq 3 \times$  RBW  
Sweep time = auto couple  
Detector = Peak  
Trace mode = max hold
3. Place the radio in continuous transmit mode, allow the trace to stabilize, view the transmitter waveform on the spectrum analyzer.

### TEST MODE

Refer to the clause 4.2

### TEST RESULT

Passed       Not Applicable

### TEST DATA

Refer to the appendix report



## 5.7. Duty Cycle

### LIMIT

N/A

### TEST CONFIGURATION

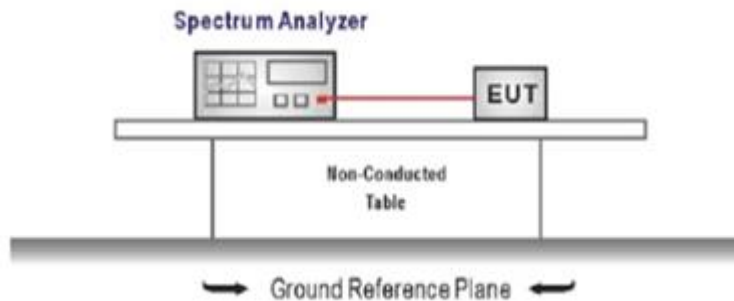

### TEST PROCEDURE

1. The transmitter output was connected to the spectrum analyzer through an attenuator, the path loss was compensated to the results for each measurement.
2. Set to the maximum power setting and enable the EUT transmit continuously
3. Use the following spectrum analyzer settings:  
Span=zero span, Frequency=centered channel, RBW= 1 MHz, VBW  $\geq$  RBW  
Sweep=as necessary to capture the entire dwell time,  
Detector function = peak, Trigger mode
4. Measure and record the duty cycle data

### TEST MODE

Refer to the clause 4.2

### TEST DATA

Refer to the appendix report

## 5.8. Conducted Band edge and Spurious Emission

### LIMIT

**FCC CFR Title 47 Part 15 Subpart C Section 15.247 (d):** In any 100 kHz bandwidth outside the frequency band in which the spread spectrum intentional radiator is operating, the radio frequency power that is produced by the intentional radiator shall be at least 20 dB below that in the 100 kHz bandwidth within the band that contains the highest level of the desired power, based on either an RF conducted or a radiated measurement.

### TEST CONFIGURATION

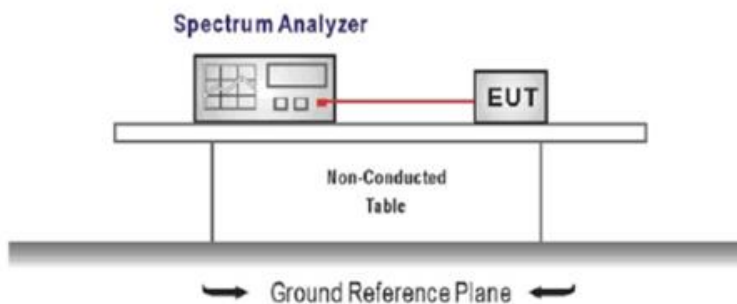

### TEST PROCEDURE

1. Connect the antenna port(s) to the spectrum analyzer input.
2. Emission level measurement  
Set the center frequency and span to encompass frequency range to be measured  
RBW = 100 kHz, VBW  $\geq 3 \times$  RBW  
Detector = peak, Sweep time = auto couple, Trace mode = max hold  
Allow trace to fully stabilize  
Use the peak marker function to determine the maximum amplitude level.
3. Place the radio in continuous transmit mode, allow the trace to stabilize, view the transmitter waveform on the spectrum analyzer.
4. Ensure that the amplitude of all unwanted emission outside of the authorized frequency band excluding restricted frequency bands) are attenuated by at least the minimum requirements specified (at least 20 dB relative to the maximum in-band peak PSD level in 100 kHz). Report the three highest emission relative to the limit.

### TEST MODE

Refer to the clause 4.2

### TEST RESULT

Passed  Not Applicable

### TEST DATA

Refer to the appendix report

## 5.9. Radiated Band edge Emission

### LIMIT

#### **FCC CFR Title 47 Part 15 Subpart C Section 15.247 (d):**

In any 100 kHz bandwidth outside the frequency band in which the spread spectrum or digitally modulated intentional radiator is operating, Radiated Emissions which fall in the restricted bands, as defined in §15.205(a), must also comply with the Radiated Emissions limits specified in §15.209(a) (see §15.205(c)).

### TEST CONFIGURATION

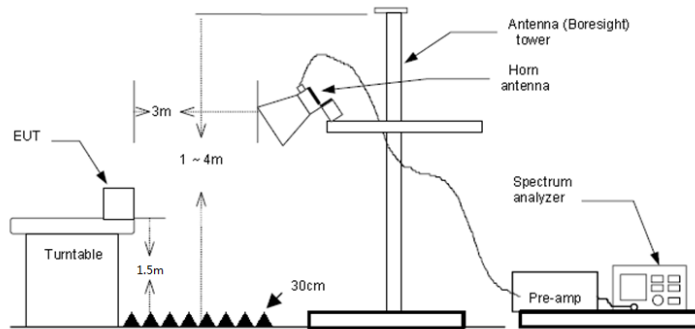

### TEST PROCEDURE

1. The EUT was setup and tested according to ANSI C63.10 .
2. The EUT is placed on a turn table which is 1.5 meter above ground. The turn table is rotated 360 degrees to determine the position of the maximum emission level.
3. The EUT was positioned such that the distance from antenna to the EUT was 3 meters.
4. The antenna is scanned from 1 meter to 4 meters to find out the maximum emission level. This is repeated for both horizontal and vertical polarization of the antenna. In order to find the maximum emission, all of the interface cables were manipulated according to ANSI C63.10 on radiated measurement.
5. Use the following spectrum analyzer settings:
  - a) Span shall wide enough to fully capture the emission being measured
  - b) Set RBW=100kHz for <1GHz, VBW=3\*RBW, Sweep time=auto, Detector=peak, Trace=max hold
  - c) Set RBW=1MHz, VBW=3MHz for >1GHz, Sweep time=auto, Detector=peak, Trace=max hold for Peak measurement

For average measurement:

  - VBW=10Hz, When duty cycle is no less than 98 percent
  - VBW $\geq$ 1/T, when duty cycle is less than 98 percent where T is the minimum transmission duration over which the transmitter is on and is transmitting at its maximum power control level for the tested mode of operation, so refer to this clause 5.6 duty cycle.

### TEST MODE

Refer to the clause 4.2

### TEST RESULT

Passed       Not Applicable

Note:

- 1) Level= Reading + Factor; Factor =Antenna Factor+ Cable Loss- Preamp Factor
- 2) Over Limit = Level– Limit
- 3) Average measurement was not performed if peak level is lower than average limit(54 dBuV/m).

Test channel		CH00			Polarity			Horizontal		
Mark	Frequency MHz	Reading dBuV/m	Antenna dB	Cable dB	Preamp dB	Level dBuV/m	Limit dBuV/m	Over limit	Remark	
1	2310.00	43.70	27.86	4.01	41.80	33.77	74.00	-40.23	Peak	
2	2390.14	55.30	27.54	4.31	41.80	45.35	74.00	-28.65	Peak	
Test channel		CH00			Polarity			Vertical		
Mark	Frequency MHz	Reading dBuV/m	Antenna dB	Cable dB	Preamp dB	Level dBuV/m	Limit dBuV/m	Over limit	Remark	
1	2310.00	43.97	27.86	4.01	41.80	34.04	74.00	-39.96	Peak	
2	2390.03	60.76	27.54	4.31	41.80	50.81	74.00	-23.19	Peak	

Test channel		CH42			Polarity			Horizontal		
Mark	Frequency MHz	Reading dBuV/m	Antenna dB	Cable dB	Preamp dB	Level dBuV/m	Limit dBuV/m	Over limit	Remark	
1	2483.49	58.70	27.33	4.18	41.80	48.41	74.00	-25.59	Peak	
2	2500.00	52.85	27.30	4.19	41.80	42.54	74.00	-31.46	Peak	
Test channel		CH42			Polarity			Vertical		
Mark	Frequency MHz	Reading dBuV/m	Antenna dB	Cable dB	Preamp dB	Level dBuV/m	Limit dBuV/m	Over limit	Remark	
1	2483.44	57.56	27.33	4.18	41.80	47.27	74.00	-26.73	Peak	
2	2500.00	43.17	27.30	4.19	41.80	32.86	74.00	-41.14	Peak	

### 5.10. Radiated Spurious Emission

**LIMIT**

**FCC CFR Title 47 Part 15 Subpart C Section 15.209**

Frequency	Limit (dBuV/m)	Value
0.009 MHz ~0.49 MHz	2400/F(kHz) @300m	Quasi-peak
0.49 MHz ~ 1.705 MHz	24000/F(kHz) @30m	Quasi-peak
1.705 MHz ~30 MHz	30 @30m	Quasi-peak

Note: Limit dBuV/m @3m = Limit dBuV/m @300m + 40\*log(300/3)= Limit dBuV/m @300m +80,  
 Limit dBuV/m @3m = Limit dBuV/m @30m +40\*log(30/3)= Limit dBuV/m @30m + 40.

Frequency	Limit (dBuV/m @3m)	Value
30MHz~88MHz	40.00	Quasi-peak
88MHz~216MHz	43.50	Quasi-peak
216MHz~960MHz	46.00	Quasi-peak
960MHz~1GHz	54.00	Quasi-peak
Above 1GHz	54.00	Average
	74.00	Peak

**TEST CONFIGURATION**

➤ 9 kHz ~ 30 MHz

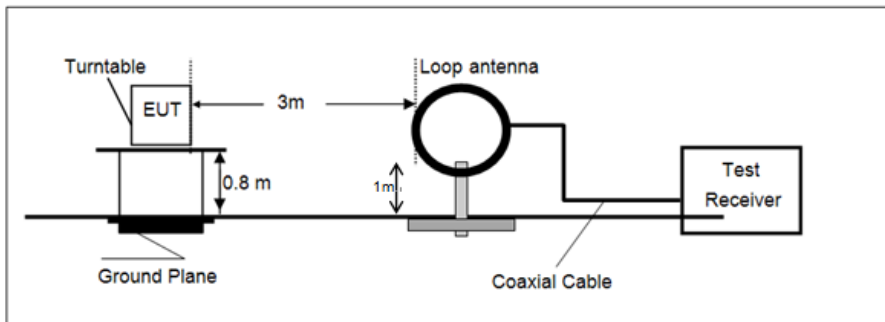

➤ 30 MHz ~ 1 GHz

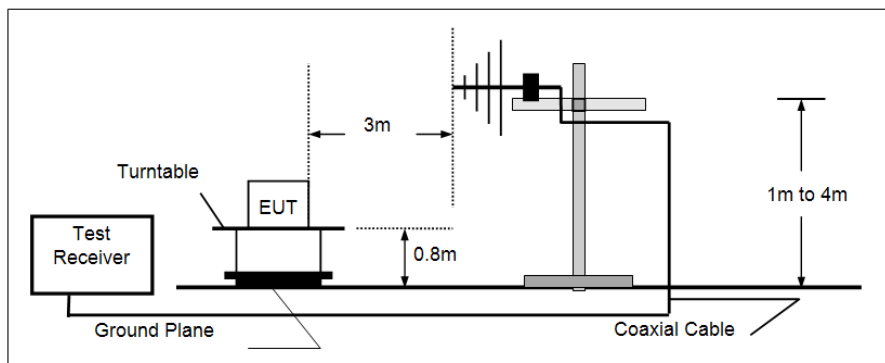

➤ Above 1 GHz

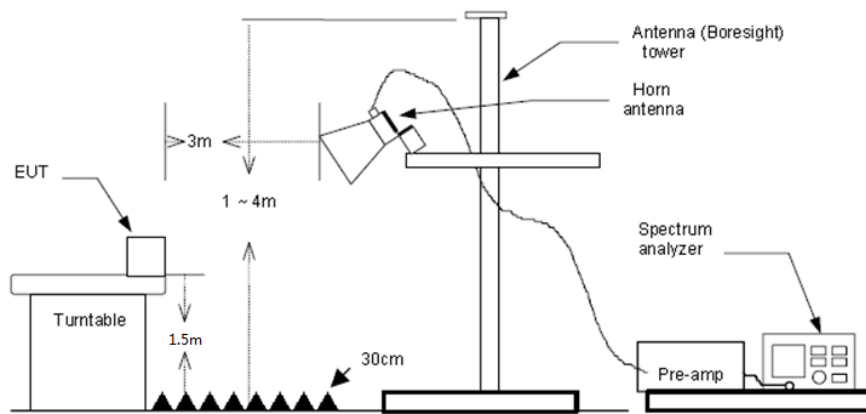

### **TEST PROCEDURE**

1. The EUT was setup and tested according to ANSI C63.10 .
2. The EUT is placed on a turn table which is 0.8 meter above ground for below 1 GHz, and 1.5 m for above 1 GHz. The turn table is rotated 360 degrees to determine the position of the maximum emission level.
3. The EUT was set 3 meters from the receiving antenna, which was mounted on the top of a variable height antenna tower.
4. For each suspected emission, the EUT was arranged to its worst case and then tune the Antenna tower (from 1 m to 4 m) and turntable (from 0 degree to 360 degrees) to find the maximum reading. A pre-amp and a high pass filter are used for the test in order to get better signal level to comply with the guidelines.
5. Set to the maximum power setting and enable the EUT transmit continuously.
6. Use the following spectrum analyzer settings
  - a) Span shall wide enough to fully capture the emission being measured;
  - b) Below 1 GHz:
    - RBW=120 kHz, VBW=300 kHz, Sweep=auto, Detector function=peak, Trace=max hold;
    - If the emission level of the EUT measured by the peak detector is 3 dB lower than the applicable limit, the peak emission level will be reported. Otherwise, the emission measurement will be repeated using the quasi-peak detector and reported.
  - c) Set RBW=1MHz, VBW=3MHz for >1GHz, Sweep time=auto, Detector=peak, Trace=max hold for Peak measurement
    - For average measurement:
      - VBW=10Hz, When duty cycle is no less than 98 percent
      - $VBW \geq 1/T$ , when duty cycle is less than 98 percent where T is the minimum transmission duration over which the transmitter is on and is transmitting at its maximum power control level for the tested mode of operation, so refer to this clause 5.6 duty cycle.

### **TEST MODE**

Refer to the clause 4.2

### **TEST RESULT**

**Passed**       **Not Applicable**

Note:

- 1) Level= Reading + Factor/Transd; Factor/Transd =Antenna Factor+ Cable Loss- Preamp Factor
- 2) Over Limit = Level– Limit
- 3) Average measurement was not performed if peak level is lower than average limit(54 dBuV/m) for above 1GHz.

**For 9 kHz ~ 30 MHz**

The EUT was pre-scanned this frequency band, found the radiated level 20dB lower than the limit, so don't show data on this report.

**For 30 MHz ~ 1000 MHz**

Have pre-scan all test channel, found CH20 which it was worst case, so only show the worst case's data on this report.

Polarization:

Horizontal

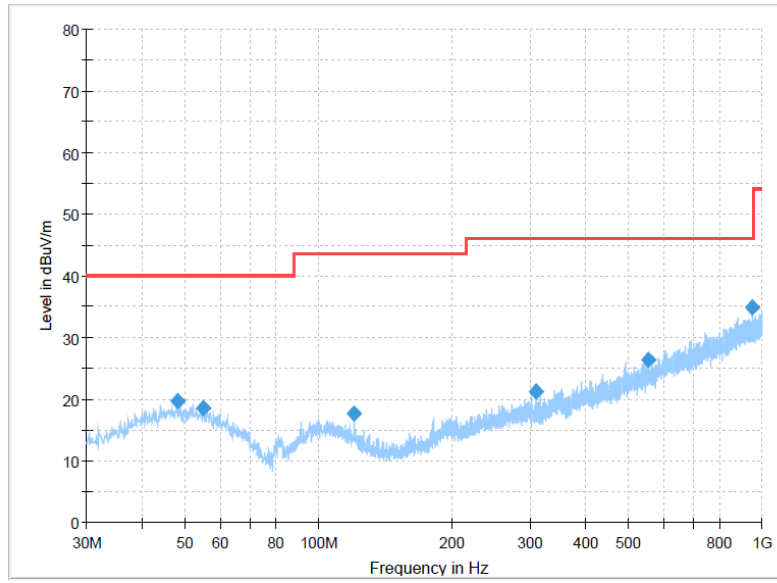

**Final Result**

Frequency (MHz)	MaxPeak (dBuV/m)	Limit (dBuV/m)	Margin (dB)	Height (cm)	Pol	Azimuth (deg)	Corr. (dB/m)
47.9450	19.70	40.00	20.30	300.0	H	208.0	-8.4
54.9775	18.47	40.00	21.53	300.0	H	248.0	-8.8
120.2100	17.63	43.50	25.87	100.0	H	338.0	-12.4
309.6025	21.23	46.00	24.77	300.0	H	113.0	-6.8
554.4063	26.48	46.00	19.52	300.0	H	216.0	-0.2
948.4688	34.97	46.00	11.03	100.0	H	211.0	7.5

Polarization:

Vertical

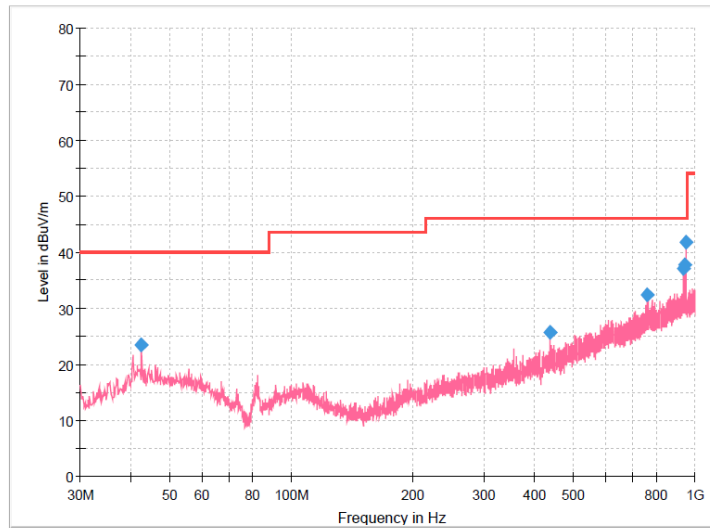

**Final Result**

Frequency (MHz)	MaxPeak (dBuV/m)	Limit (dBuV/m)	Margin (dB)	Height (cm)	Pol	Azimuth (deg)	Corr. (dB/m)
42.4888	23.49	40.00	16.51	100.0	V	99.0	-8.8
437.5213	25.80	46.00	20.20	100.0	V	328.0	-2.9
763.4413	32.50	46.00	13.50	100.0	V	356.0	4.4
935.0100	37.13	46.00	8.87	100.0	V	273.0	7.4
945.1950	37.86	46.00	8.14	100.0	V	23.0	7.5
948.4688	41.86	46.00	4.14	100.0	V	87.0	7.5



**For 1 GHz ~ 25 GHz**

Test channel		CH00			Polarity		Horizontal		
Mark	Frequency MHz	Reading dBuV/m	Antenna dB	Cable dB	Preamp dB	Level dBuV/m	Limit dBuV/m	Over limit	Remark
1	3681.47	44.31	29.20	5.14	41.60	37.05	74.00	-36.95	Peak
2	4846.37	49.99	31.21	6.21	41.30	46.11	74.00	-27.89	Peak
3	7264.28	43.50	36.03	7.66	40.96	46.23	74.00	-27.77	Peak
4	11428.08	40.69	40.43	10.31	42.30	49.13	74.00	-24.87	Peak

Test channel		CH00			Polarity		Vertical		
Mark	Frequency MHz	Reading dBuV/m	Antenna dB	Cable dB	Preamp dB	Level dBuV/m	Limit dBuV/m	Over limit	Remark
1	3049.39	45.03	28.60	4.65	41.62	36.66	74.00	-37.34	Peak
2	4846.37	46.56	31.21	6.21	41.30	42.68	74.00	-31.32	Peak
3	8002.06	41.70	37.00	8.00	40.81	45.89	74.00	-28.11	Peak
4	11486.41	41.10	40.49	10.35	42.30	49.64	74.00	-24.36	Peak

Test channel		CH20			Polarity		Horizontal		
Mark	Frequency MHz	Reading dBuV/m	Antenna dB	Cable dB	Preamp dB	Level dBuV/m	Limit dBuV/m	Over limit	Remark
1	3480.97	44.66	28.89	5.00	41.60	36.95	74.00	-37.05	Peak
2	5352.19	40.38	31.41	6.34	40.92	37.21	74.00	-36.79	Peak
3	8002.06	39.47	37.00	8.00	40.81	43.66	74.00	-30.34	Peak
4	10427.37	38.94	39.93	9.72	40.69	47.90	74.00	-26.10	Peak

Test channel		CH20			Polarity		Vertical		
Mark	Frequency MHz	Reading dBuV/m	Antenna dB	Cable dB	Preamp dB	Level dBuV/m	Limit dBuV/m	Over limit	Remark
1	4547.56	40.87	30.70	6.21	41.40	36.38	74.00	-37.62	Peak
2	5940.97	39.74	32.30	6.83	40.65	38.22	74.00	-35.78	Peak
3	7981.72	39.87	36.96	7.99	40.85	43.97	74.00	-30.03	Peak
4	10374.42	39.13	39.82	9.69	40.65	47.99	74.00	-26.01	Peak

Test channel		CH42			Polarity		Horizontal		
Mark	Frequency MHz	Reading dBuV/m	Antenna dB	Cable dB	Preamp dB	Level dBuV/m	Limit dBuV/m	Over limit	Remark
1	3402.13	44.56	28.41	5.08	41.60	36.45	74.00	-37.55	Peak
2	4920.96	53.74	31.20	6.06	41.20	49.80	74.00	-24.20	Peak
3	7394.88	46.30	36.20	7.78	41.00	49.28	74.00	-24.72	Peak
4	10480.59	40.54	39.98	9.75	40.86	49.41	74.00	-24.59	Peak

  

Test channel		CH42			Polarity		Vertical		
Mark	Frequency MHz	Reading dBuV/m	Antenna dB	Cable dB	Preamp dB	Level dBuV/m	Limit dBuV/m	Over limit	Remark
1	3472.12	43.55	28.83	4.98	41.60	35.76	74.00	-38.24	Peak
2	4920.96	51.59	31.20	6.06	41.20	47.65	74.00	-26.35	Peak
3	7394.88	43.39	36.20	7.78	41.00	46.37	74.00	-27.63	Peak
4	10453.95	40.61	39.95	9.73	40.77	49.52	74.00	-24.48	Peak

## 6. TEST SETUP PHOTOS

Radiated Emission

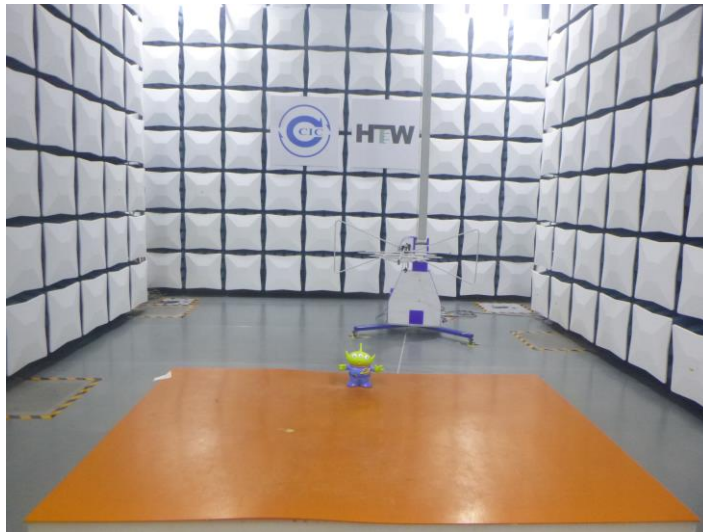
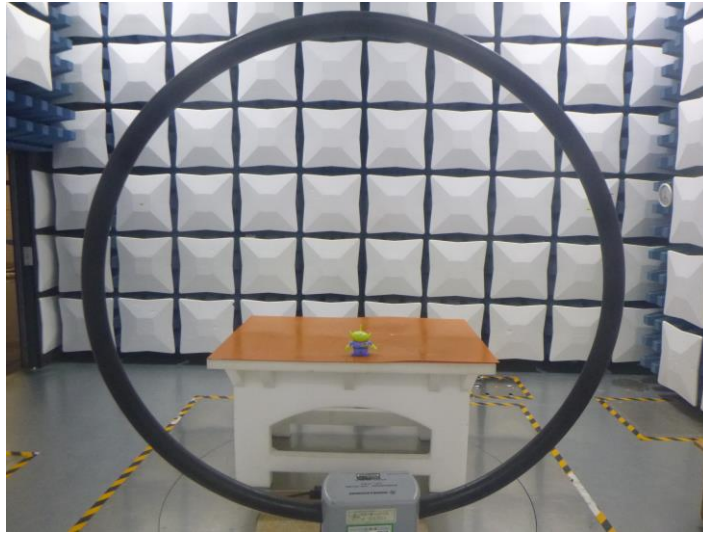

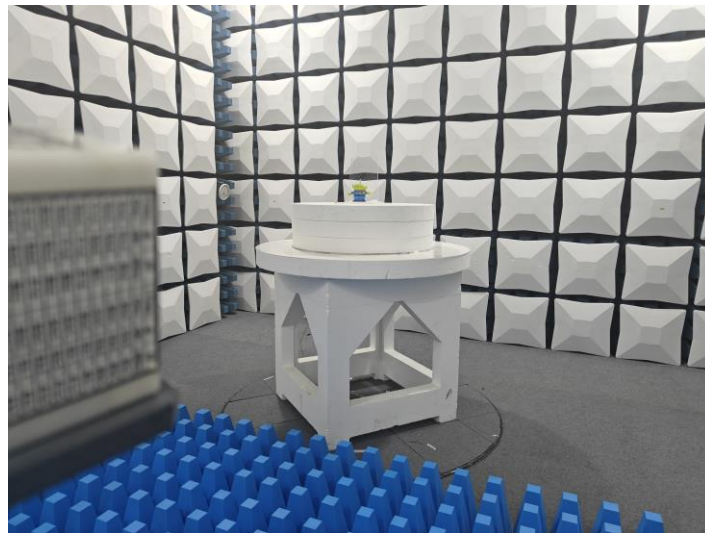
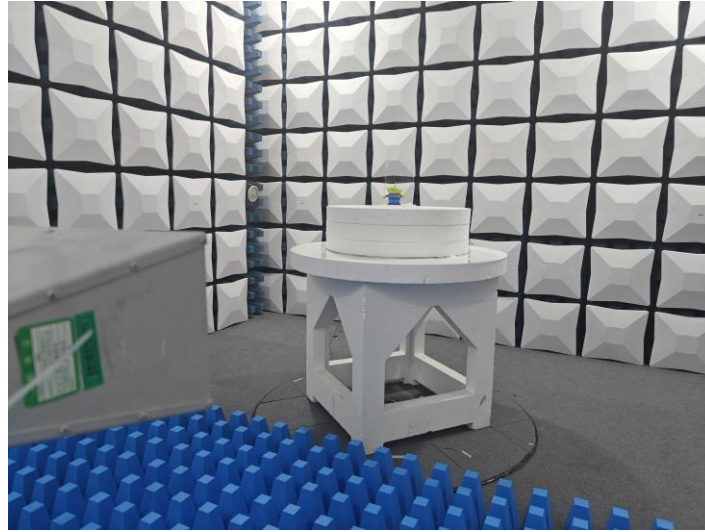

## 7. EXTERNAL AND INTERNAL PHOTOS

### 7.1. External Photos



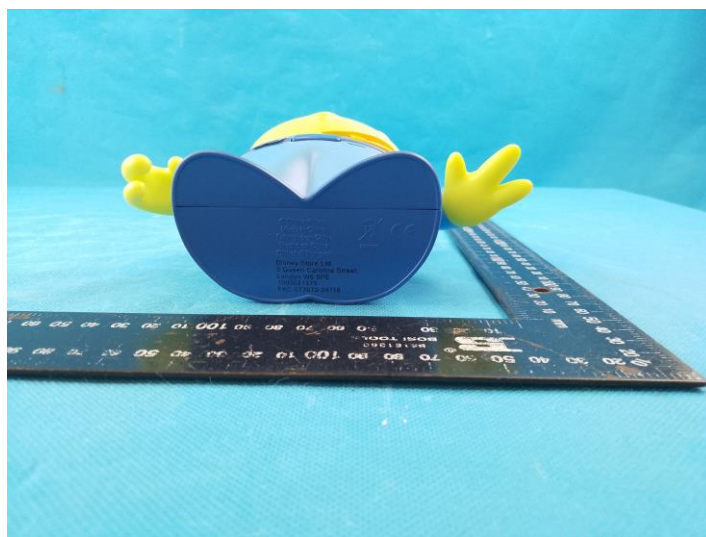

## 7.2. Internal Photos

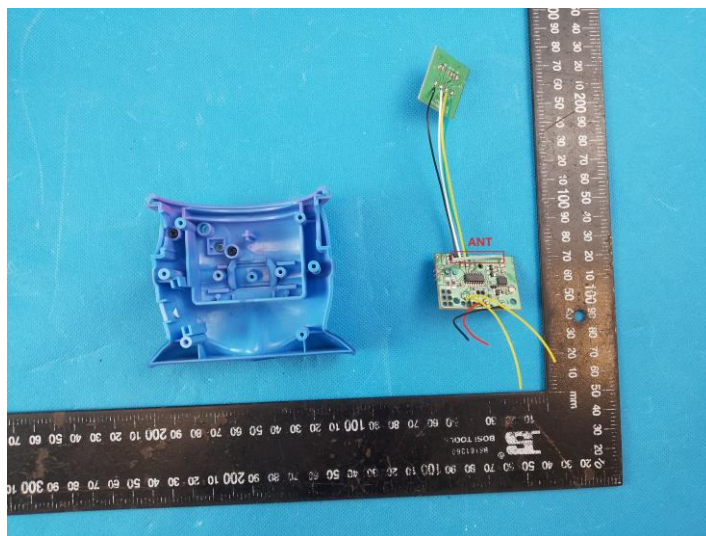
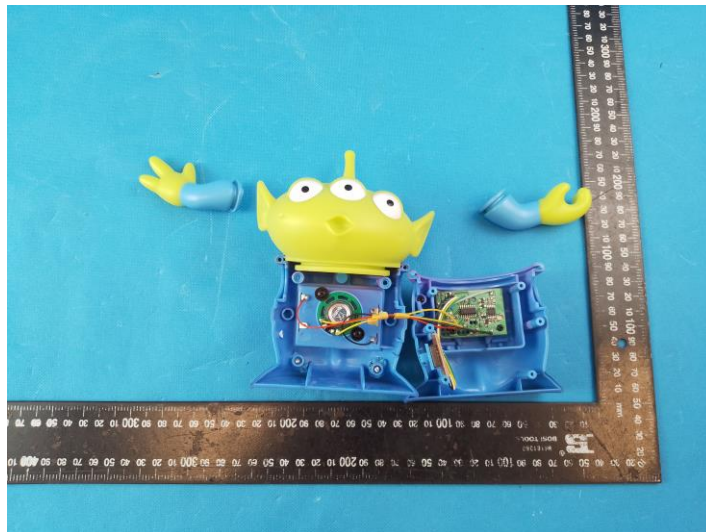
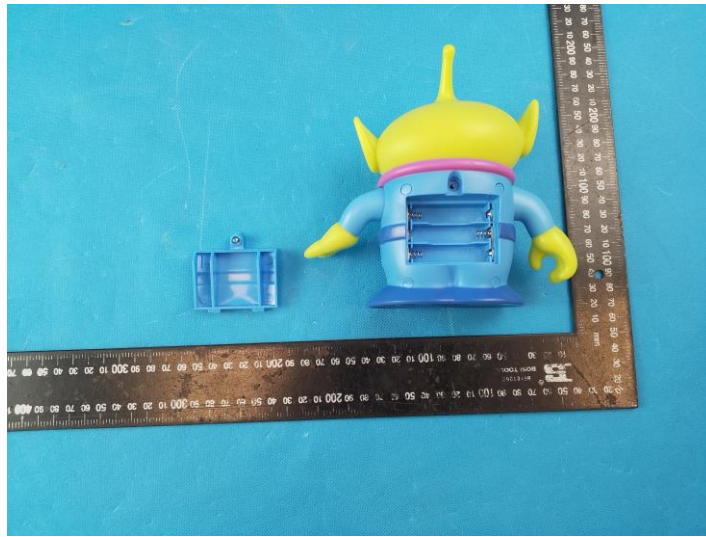

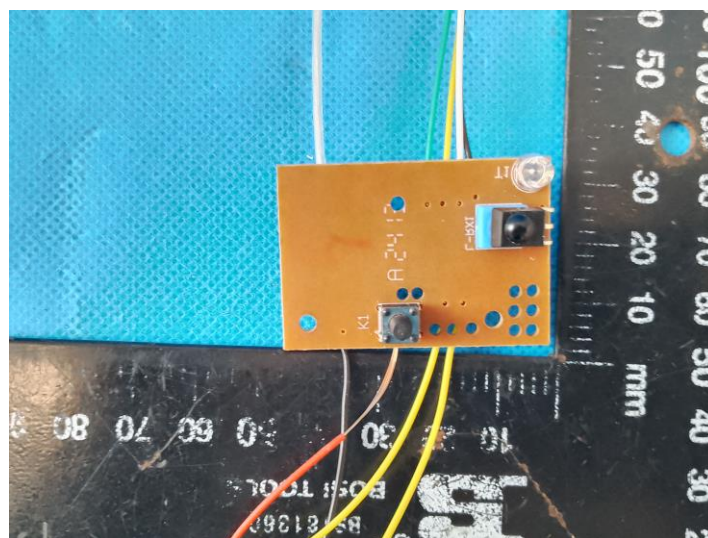
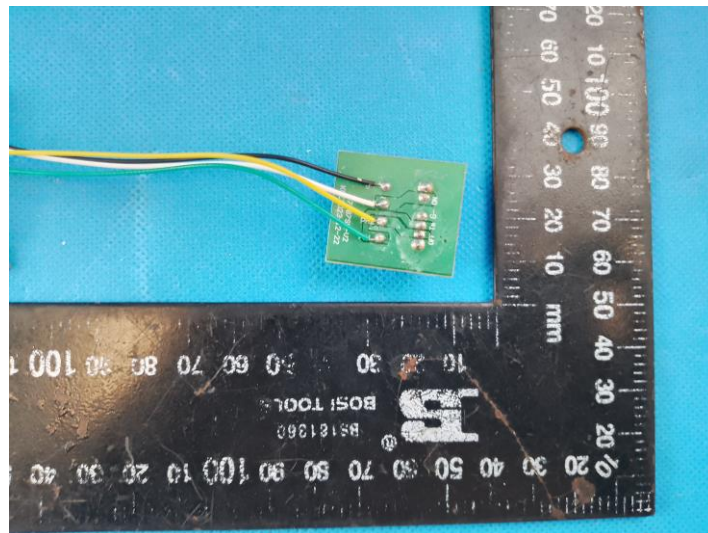
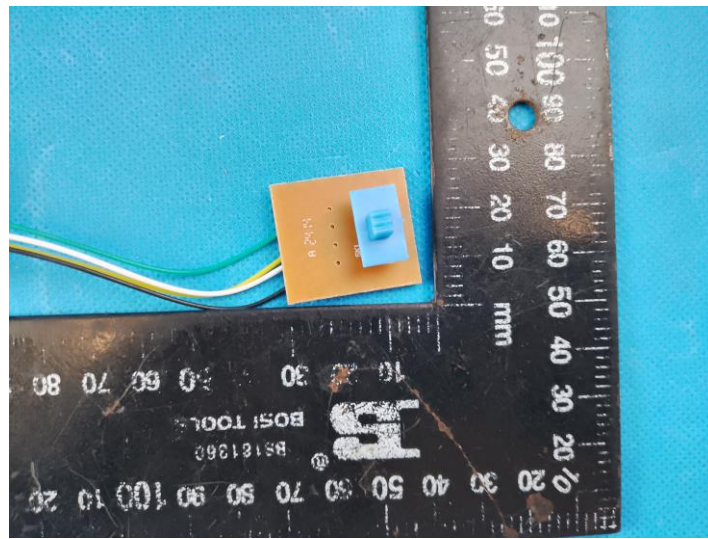

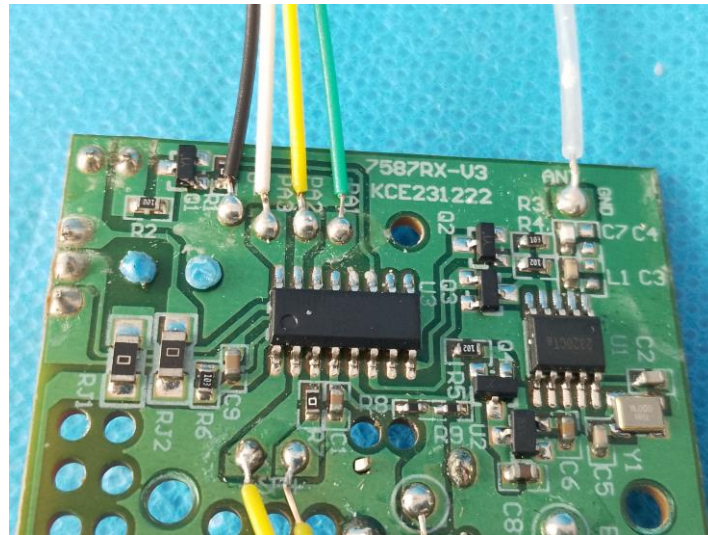
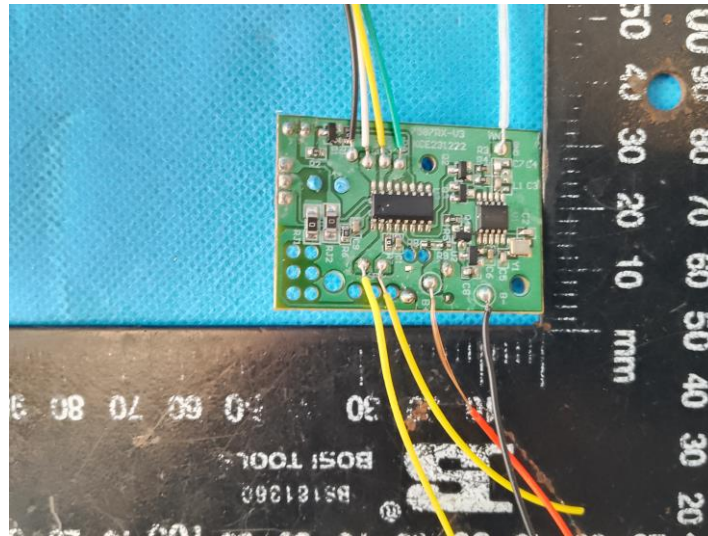

## 8. APPENDIX REPORT



# APPENDIX REPORT

Project No.	SHT2406017001W	Radio Specification	GFSK
Test sample No.	YPHT24060170001_01	Model No.	2401-DW13054(7587-T)
Start test date	2024-06-24	Finish date	2024-06-25
Temperature	24.8°C	Humidity	45%
Test Engineer	Chenxin Ling	Auditor	Xiaodong Zheo

Appendix clause	Test item	Result
A	Peak Output Power	Pass
B	Power Spectral Density	Pass
C	6 dB Bandwidth	Pass
D	99% Occupied Bandwidth	Pass
E	Duty cycle	Pass
F	Band edge and Spurious Emissions (conducted)	Pass

**Appendix A: Peak Output Power**

Type	Channel	Peak Output power (dBm)	Average Output power (dBm)	Limit (dBm)	Result
GFSK	00	-2.53	-2.59	≤ 30.00	Pass
	20	-2.51	-2.55		
	42	-2.47	-2.50		

CH00

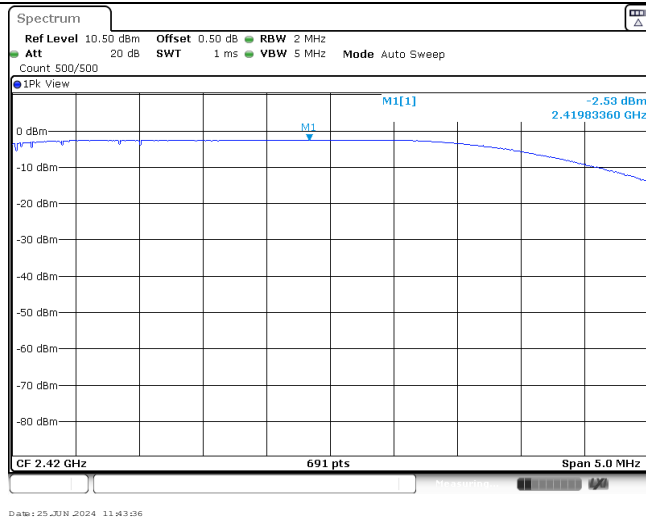

CH20

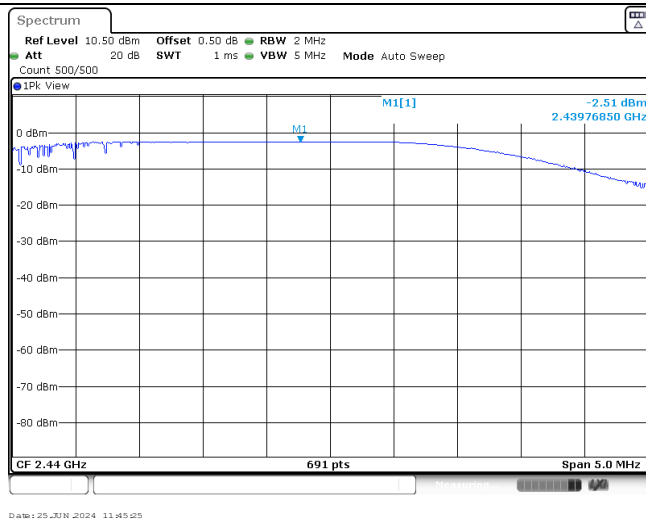

CH42

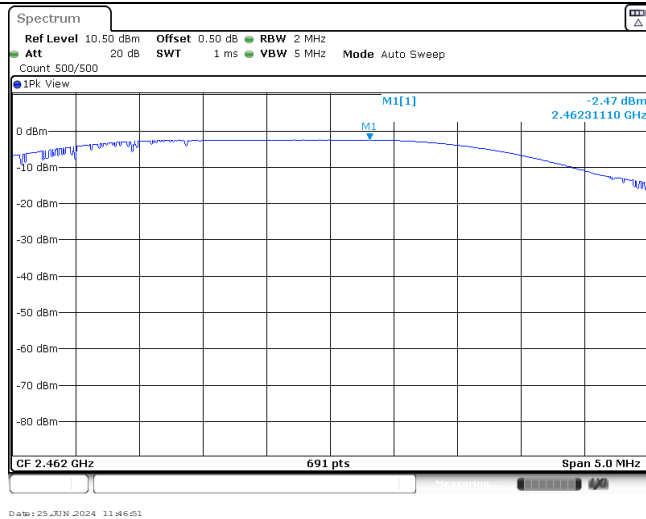

**Appendix B: Power Spectral Density**

Type	Channel	Power Spectral Density(dBm/3KHz)	Limit (dBm/3KHz)	Result
GFSK	00	-6.66	≤8.00	Pass
	20	-6.59		
	42	-5.98		

CH00

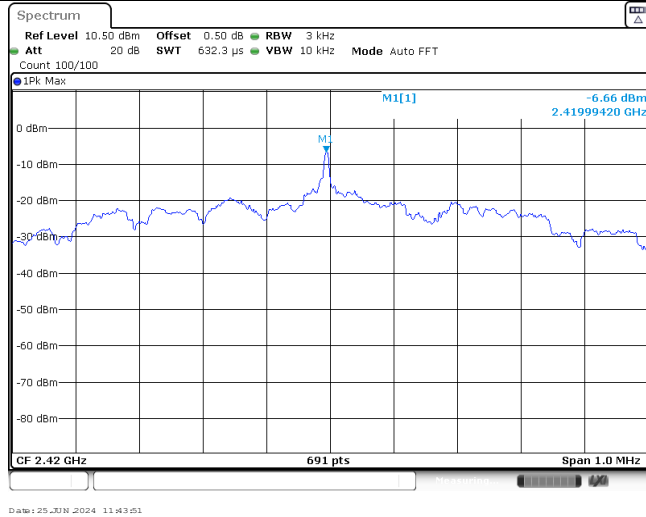

CH20

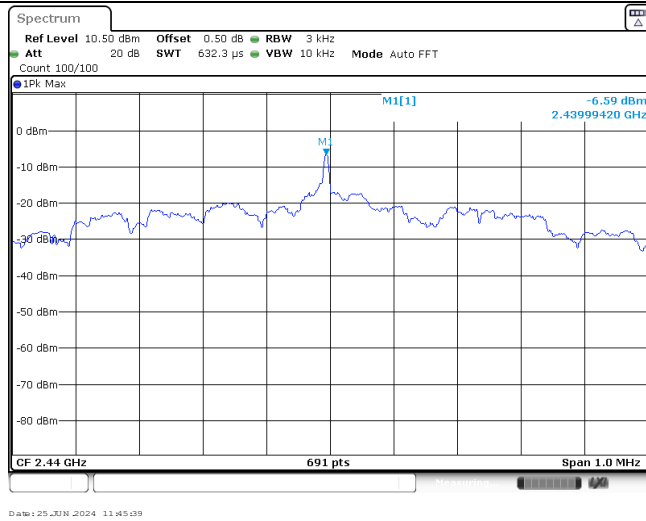

CH42

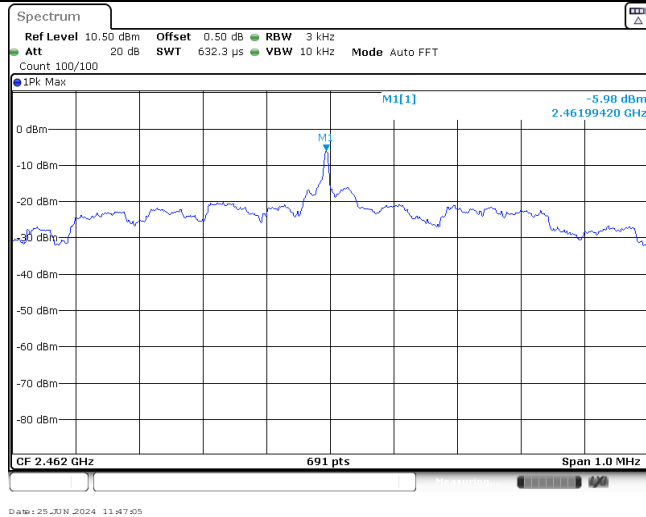

**Appendix C: 6dB bandwidth**

Type	Channel	6dB Bandwidth(kHz)	Limit (kHz)	Result
GFSK	00	1800.00	≥500	Pass
	20	1290.00		
	42	1230.00		

CH00

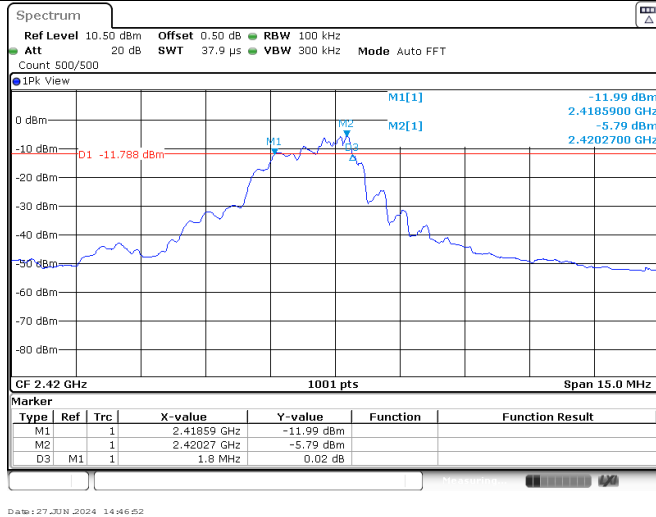

CH20

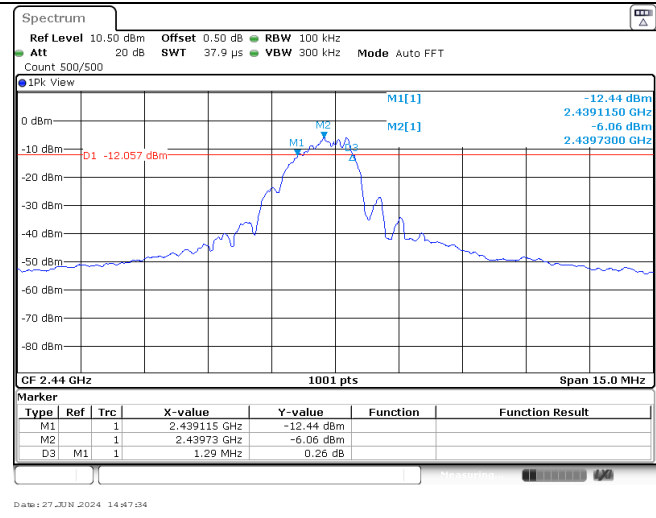

CH42

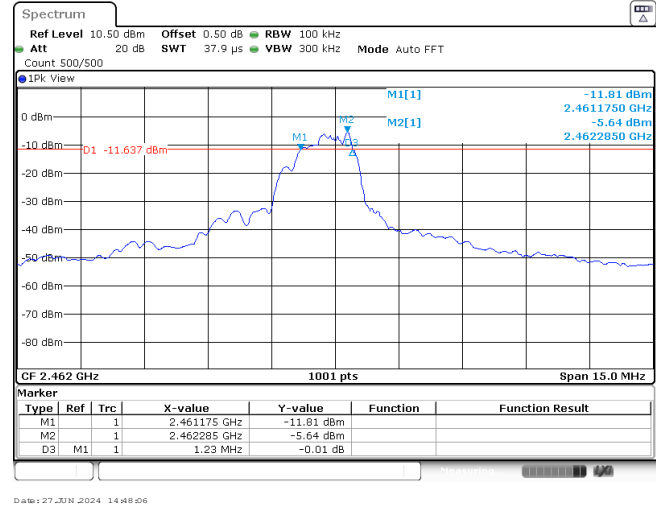

**Appendix D: 99% Occupied Bandwidth**

Type	Channel	99% Occupied Bandwidth(MHz)	Limit (kHz)	Result
GFSK	00	2.46	-	Pass
	20	2.02		
	42	1.75		



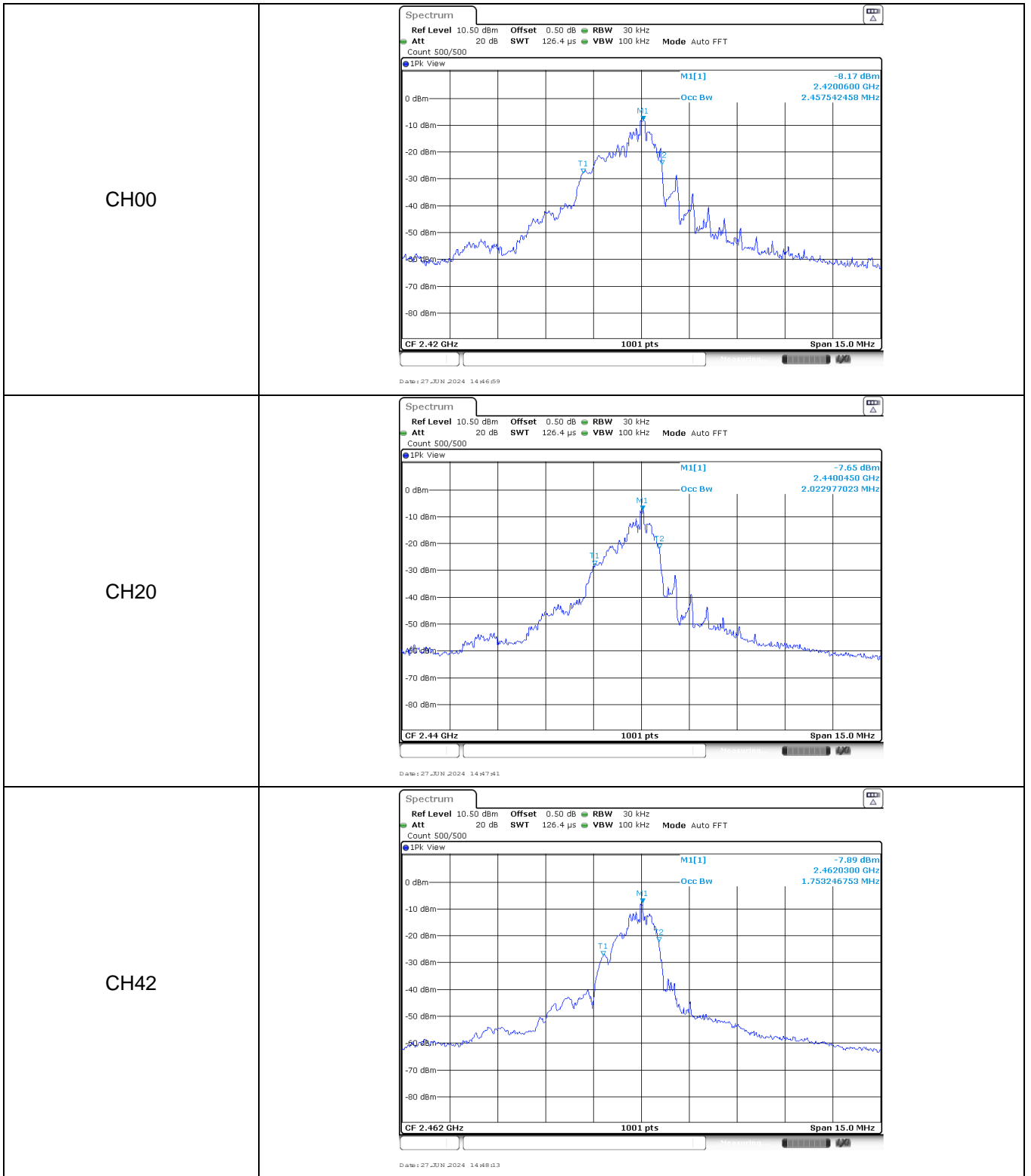

### Appendix E: Duty cycle

Test Frequency (MHz)	T <sub>on</sub> time for single burst (ms)	T <sub>period</sub> (ms)	Duty cycle	1/T <sub>on</sub> time (kHz)
2440	0.40	2.40	16.67%	2.50

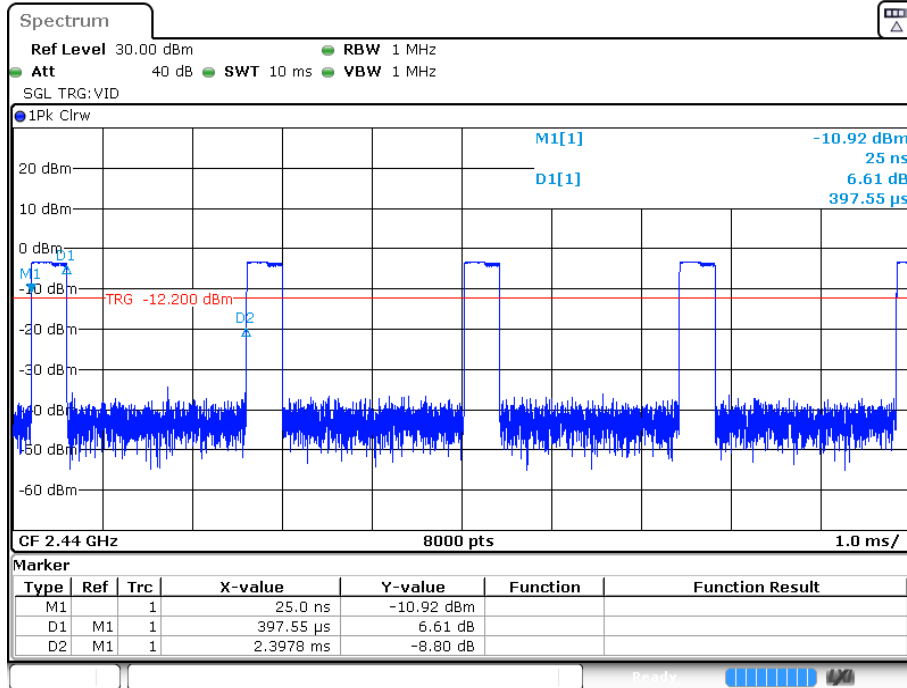

Date: 25 JUN 2024 11:44:56

### Appendix F: Band edge and Spurious Emissions (conducted)

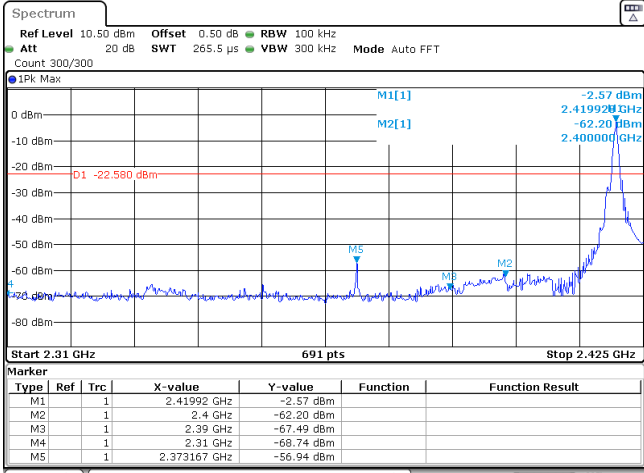
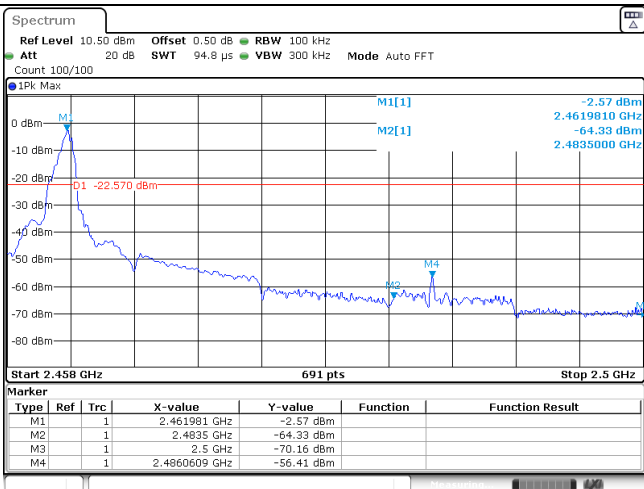
Test Item:	Band edge																																										
<p style="text-align: center;">CH00</p>	 <p><b>Spectrum</b>          Ref Level 10.50 dBm Offset 0.50 dB RBW 100 kHz          Att 20 dB SWT 265.5 μs VBW 300 kHz Mode Auto FFT          Count 300/300          1Pk Max</p> <p>Start 2.31 GHz 691 pts Stop 2.425 GHz</p> <table border="1"> <thead> <tr> <th>Type</th> <th>Ref</th> <th>Trc</th> <th>X-value</th> <th>Y-value</th> <th>Function</th> <th>Function Result</th> </tr> </thead> <tbody> <tr> <td>M1</td> <td>1</td> <td></td> <td>2.41992 GHz</td> <td>-2.57 dBm</td> <td></td> <td></td> </tr> <tr> <td>M2</td> <td>1</td> <td></td> <td>2.4 GHz</td> <td>-62.20 dBm</td> <td></td> <td></td> </tr> <tr> <td>M3</td> <td>1</td> <td></td> <td>2.39 GHz</td> <td>-67.49 dBm</td> <td></td> <td></td> </tr> <tr> <td>M4</td> <td>1</td> <td></td> <td>2.31 GHz</td> <td>-68.74 dBm</td> <td></td> <td></td> </tr> <tr> <td>M5</td> <td>1</td> <td></td> <td>2.379167 GHz</td> <td>-56.94 dBm</td> <td></td> <td></td> </tr> </tbody> </table> <p>Date: 25 JUN 2024 11:44:00</p>	Type	Ref	Trc	X-value	Y-value	Function	Function Result	M1	1		2.41992 GHz	-2.57 dBm			M2	1		2.4 GHz	-62.20 dBm			M3	1		2.39 GHz	-67.49 dBm			M4	1		2.31 GHz	-68.74 dBm			M5	1		2.379167 GHz	-56.94 dBm		
Type	Ref	Trc	X-value	Y-value	Function	Function Result																																					
M1	1		2.41992 GHz	-2.57 dBm																																							
M2	1		2.4 GHz	-62.20 dBm																																							
M3	1		2.39 GHz	-67.49 dBm																																							
M4	1		2.31 GHz	-68.74 dBm																																							
M5	1		2.379167 GHz	-56.94 dBm																																							
<p style="text-align: center;">CH42</p>	 <p><b>Spectrum</b>          Ref Level 10.50 dBm Offset 0.50 dB RBW 100 kHz          Att 20 dB SWT 94.8 μs VBW 300 kHz Mode Auto FFT          Count 100/100          1Pk Max</p> <p>Start 2.458 GHz 691 pts Stop 2.5 GHz</p> <table border="1"> <thead> <tr> <th>Type</th> <th>Ref</th> <th>Trc</th> <th>X-value</th> <th>Y-value</th> <th>Function</th> <th>Function Result</th> </tr> </thead> <tbody> <tr> <td>M1</td> <td>1</td> <td></td> <td>2.461981 GHz</td> <td>-2.57 dBm</td> <td></td> <td></td> </tr> <tr> <td>M2</td> <td>1</td> <td></td> <td>2.4635 GHz</td> <td>-64.33 dBm</td> <td></td> <td></td> </tr> <tr> <td>M3</td> <td>1</td> <td></td> <td>2.5 GHz</td> <td>-70.16 dBm</td> <td></td> <td></td> </tr> <tr> <td>M4</td> <td>1</td> <td></td> <td>2.4860609 GHz</td> <td>-56.41 dBm</td> <td></td> <td></td> </tr> </tbody> </table> <p>Date: 25 JUN 2024 11:47:14</p>	Type	Ref	Trc	X-value	Y-value	Function	Function Result	M1	1		2.461981 GHz	-2.57 dBm			M2	1		2.4635 GHz	-64.33 dBm			M3	1		2.5 GHz	-70.16 dBm			M4	1		2.4860609 GHz	-56.41 dBm									
Type	Ref	Trc	X-value	Y-value	Function	Function Result																																					
M1	1		2.461981 GHz	-2.57 dBm																																							
M2	1		2.4635 GHz	-64.33 dBm																																							
M3	1		2.5 GHz	-70.16 dBm																																							
M4	1		2.4860609 GHz	-56.41 dBm																																							

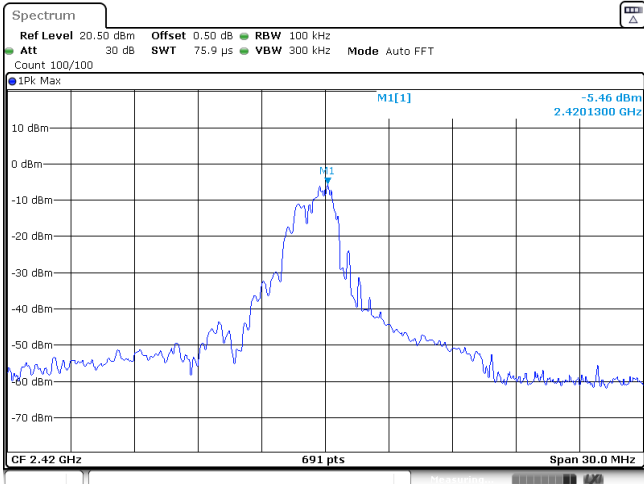
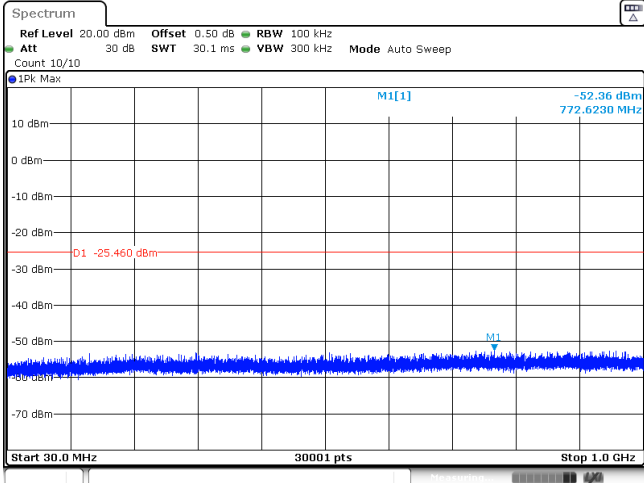
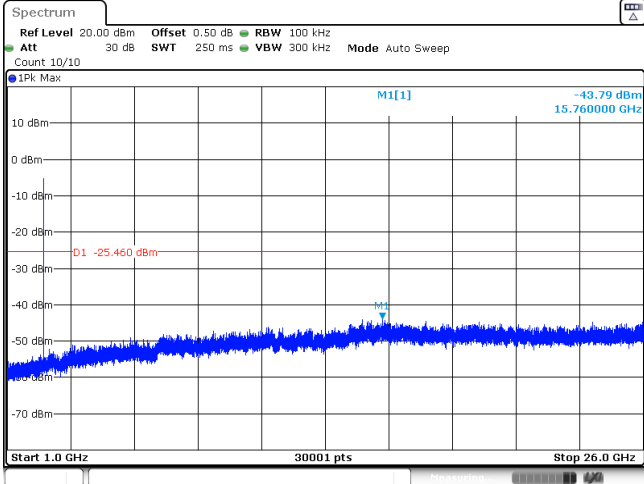
Test Item:	SE
<p>CH00 Reference level</p>	 <p>Spectrum</p> <p>Ref Level 20.50 dBm Offset 0.50 dB RBW 100 kHz Att 30 dB SWT 75.9 <math>\mu</math>s VBW 300 kHz Mode Auto FFT Count 100/100</p> <p>1Pk Max M1[1] -5.46 dBm 2.4201300 GHz</p> <p>CF 2.42 GHz 691 pts Span 30.0 MHz</p> <p>Date: 25 JUN 2024 11:44:06</p>
<p>CH00 30MHz~1000MHz</p>	 <p>Spectrum</p> <p>Ref Level 20.00 dBm Offset 0.50 dB RBW 100 kHz Att 30 dB SWT 30.1 ms VBW 300 kHz Mode Auto Sweep Count 10/10</p> <p>1Pk Max M1[1] -52.36 dBm 772.6230 MHz</p> <p>D1 -25.460 dBm</p> <p>Start 30.0 MHz 30001 pts Stop 1.0 GHz</p> <p>Date: 25 JUN 2024 11:44:01</p>
<p>CH00 1GHz~26GHz</p>	 <p>Spectrum</p> <p>Ref Level 20.00 dBm Offset 0.50 dB RBW 100 kHz Att 30 dB SWT 250 ms VBW 300 kHz Mode Auto Sweep Count 10/10</p> <p>1Pk Max M1[1] -43.79 dBm 15.760000 GHz</p> <p>D1 -25.460 dBm</p> <p>Start 1.0 GHz 30001 pts Stop 26.0 GHz</p> <p>Date: 25 JUN 2024 11:44:06</p>

CH20  
Reference level

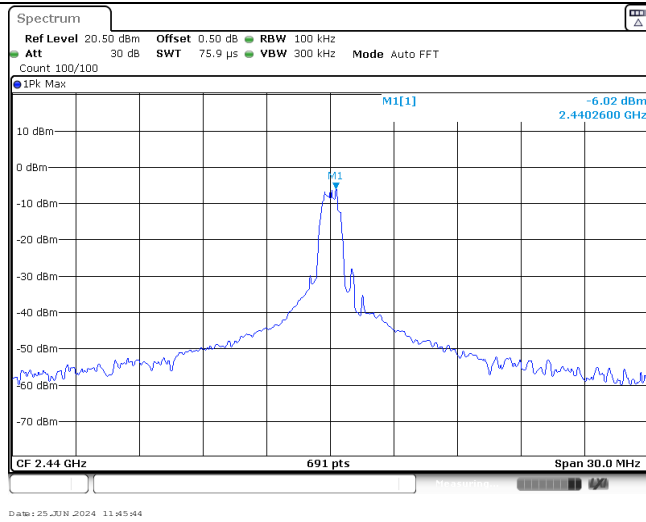

CH20  
30MHz~1000MHz

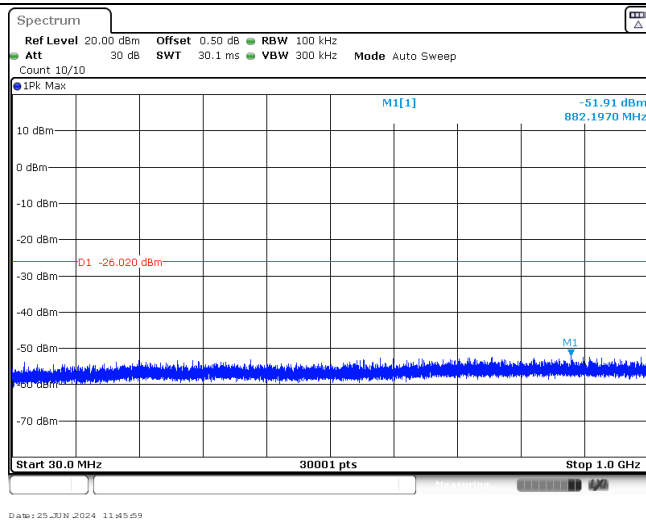

CH20  
1GHz~26GHz

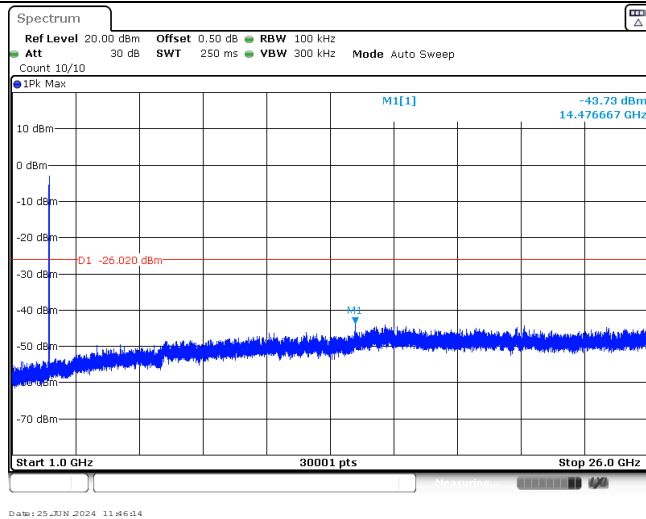

CH42  
Reference level

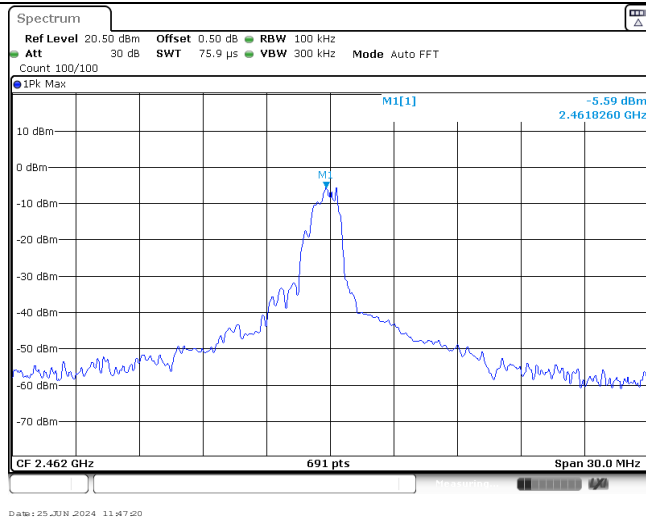

CH42  
30MHz~1000MHz

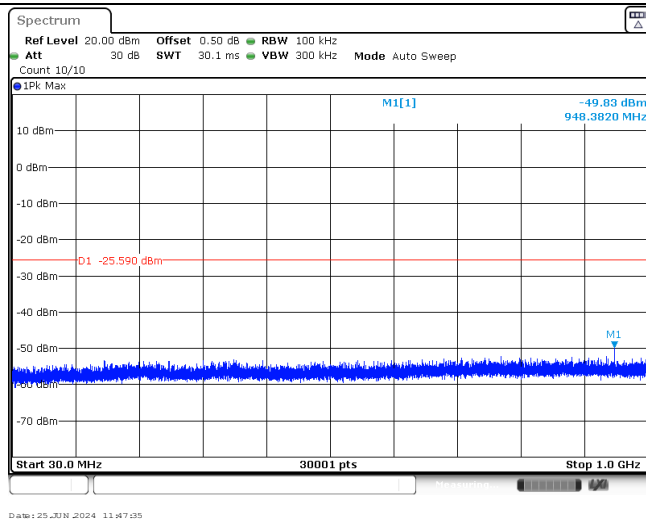

CH42  
1GHz~26GHz

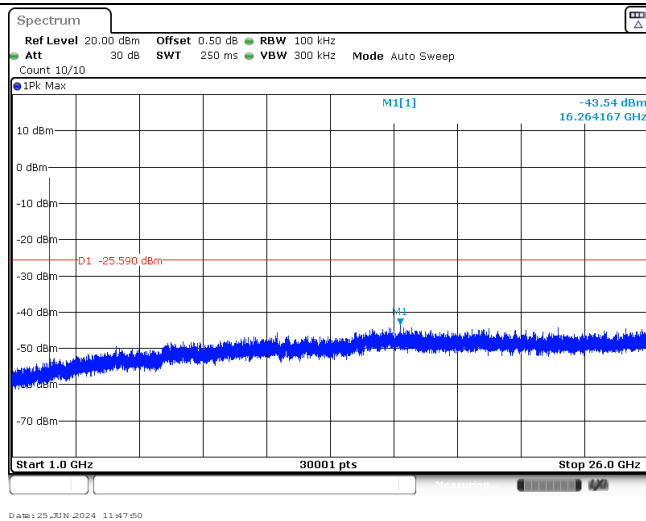

-----End of Report-----