



No.198 Kezhu Road, Science Town Economic& Technology
Development District Guangzhou, China 510663 Telephone:
Telephone: +86 (0) 20 82155555
Fax: +86 (0) 20 82075059
Email: sgs_internet_operations@sgs.com

FEDERAL COMMUNICATIONS COMMISSION
Registration number: 282399

Report No.: SZEMO071002782RFI
Page: 1 of 13
FCC ID: SIP-1195-A

TEST REPORT

Application No. : SZEMO071002782RF(SGS SZ NO.: SZTYR071002562/EL)
Applicant/Supplier: MEGAGAIN INTERNATIONAL LTD.,
Buyer: DISNEY
FCC ID: SIP-1195-A
Fundamental Carrier 2414MHz
Equipment Under Test (EUT):
Name: Remote Control Video Camera Car
Item No: 0762-TCP1585(1195-W)
Country of Destination: U.S.A.
Labelled Age Grading: 3+ YEARS
Country of Origin: China
Standards: FCC PART 15: 2007 Section 15.249
Date of Receipt: 12 October 2007
Date of Test: 15 to 18 October 2007
Date of Issue: 05 November 2007

Test Result :	PASS *
----------------------	---------------

* In the configuration tested, the EUT complied with the standards specified above.

Authorized Signature:

Robinson Lo
Manager

The manufacturer should ensure that all products in series production are in conformity with the product sample detailed in this report. If the product in this report is used in any configuration other than that detailed in the report, the manufacturer must ensure the new system complies with all relevant standards. Any mention of SGS International Electrical Approvals or testing done by SGS International Electrical Approvals in connection with, distribution or use of the product described in this report must be approved by SGS International Electrical Approvals in writing.

The report must not be used by the client to claim product certification, approval, or endorsement by NVLAP, NIST, or any agency of the federal government. All test results in this report can be traceable to National or International Standards.

This Test Report is issued by the Company subject to its General Conditions of Service printed overleaf. Attention is drawn to the limitations of liability, indemnification and jurisdictional issues defined therein. The results shown in this test report refer only to the sample(s) tested unless otherwise stated. This Test Report cannot be reproduced, except in full, without prior written permission of the Company.



2 Test Summary

Test	Test Requirement	Standard Paragraph	Result
Flied Strength of Fundamental	FCC PART 15 : 2007	Section 15.249 (a)	PASS
Flied Strength of Harmornics or other Frequency	FCC PART 15 : 2007	Section 15.249 (a) Section 15.209	PASS
Occupied Bandwidth	FCC PART 15 : 2007	Section 15.249	PASS
Band Edges Measurement	FCC PART 15 : 2007	Section 15.249 (d)	PASS



3 Contents

	Page
1 COVER PAGE.....	1
2 TEST SUMMARY	2
3 CONTENTS	3
4 GENERAL INFORMATION.....	4
4.1 CLIENT INFORMATION	4
4.2 GENERAL DESCRIPTION OF E.U.T.....	4
4.3 DESCRIPTION OF SUPPORT UNITS	4
4.4 STANDARDS APPLICABLE FOR TESTING.....	4
4.5 TEST LOCATION	4
4.6 OTHER INFORMATION REQUESTED BY THE CUSTOMER.....	4
4.7 TEST FACILITY	5
5 TEST RESULTS	6
5.1 TEST INSTRUMENTS.....	6
5.2 E.U.T. OPERATION	6
5.3 TEST PROCEDURE & MEASUREMENT DATA	7
5.3.1 <i>Radiated Emissions</i>	7
5.3.2 <i>Occupied Bandwidth & Band Edge</i>	11-13



4 General Information

4.1 Client Information

Applicant Name: MEGAGAIN INTERNATIONAL LTD.,
Applicant Address: RM 1908, GREENFIELD TOWER, CONCORDIA PLAZA, 1, SCIENCE MUSEUM ROAD, T.S.T. EAST, KLN.

4.2 General Description of E.U.T.

Product Name: Remote Control Video Camera Car
Power Supply: 0762-TCP1585(1195-W)
Power Cord: N/A-

4.3 Description of Support Units

The EUT was tested as an independent unit: Remote Control Video Camera Car.

4.4 Standards Applicable for Testing

The customer requested FCC tests for Remote Control Video Camera Car.
The standard used was FCC PART 15, SUBPART C (2007) section 15.249.

4.5 Test Location

All tests were performed at:

SGS-CSTC Standards Technical Services Co., Ltd., Guangzhou EMC Laboratory, No.198 Kezhu Road, Science Town Economic& Technology Development District Guangzhou, China 510663

Tel: +86 20 82155555 Fax: +86 20 82075059

No tests were sub-contracted.

4.6 Other Information Requested by the Customer

None.



4.7 Test Facility

The test facility is recognized, certified, or accredited by the following organizations:

- **NVLAP – Lab Code: 200611-0**
SGS-CSTC Standards Technical Services Co., Ltd., Guangzhou EMC Laboratory is recognized under the National Voluntary Laboratory Accreditation Program (NVLAP/NIST). NVLAP Code: 200611-0.
- **ACA**
SGS-CSTC Standards Technical Services Co., Ltd., EMC Laboratory can also perform testing for the Australian C-Tick mark as a result of our NVLAP accreditation.
- **VCCI**
The 3m Semi-anechoic chamber and Shielded Room (7.5m x 4.0m x 3.0m) of SGS-CSTC Standards Technical Services Co., Ltd. have been registered in accordance with the Regulations for Voluntary Control Measures with Registration No.: R-2197 and C-2383 respectively.
Date of Registration: September 29, 2005. Valid until September 28, 2008.
- **SGS UK(Certificate No.: 32), SGS-TUV SAARLAND and SGS-FIMKO**
Have approved SGS-CSTC Standards Technical Services Co., Ltd., EMC Laboratory as a supplier of EMC TESTING SERVICES and SAFETY TESTING SERVICES.
- **CNAS L0167**
SGS-CSTC Standards Technical Services Co., Ltd., EMC Laboratory has been assessed and in compliance with CNAS-CL01:2006 accreditation criteria for testing laboratories (identical to ISO/IEC 17025:2005 General Requirements) for the Competence of Testing Laboratories.
- **FCC – Registration No.: 556682**
SGS-CSTC Standards Technical Services Co., Ltd., Shenzhen EMC Laboratory has been registered and fully described in a report filed with the (FCC) Federal Communications Commission. The acceptance letter from the FCC is maintained in our files. Registration 556682, Aug. 04, 2005
- **Industry Canada (IC)**
The 3m Semi-anechoic chamber of SGS-CSTC Standards Technical Services Co., Ltd. has been registered by Certification and Engineering Bureau of Industry Canada for radio equipment testing with Registration No.: 6002.



5 Test Results

5.1 Test Instruments

R&TTE RE in Chamber						
Item	Test Equipment	Manufacturer	Model No.	Inventory No.	Cal.Date (dd-mm-yy)	Cal.Due date (dd-mm-yy)
1	3m Semi-Anechoic Chamber	ETS-LINDGREN	N/A	SEL0017	16-06-2007	15-06-2009
2	EMI Test Receiver	Rohde & Schwarz	ESIB26	SEL0023	14-12-2006	13-12-2007
3	EMI Test software	AUDIX	E3	SEL0050	N/A	N/A
4	Coaxial cable	SGS	N/A	SEL0028	01-06-2007	31-05-2008
5	Coaxial cable	SGS	N/A	SEL0027	20-10-2007	19-10-2008
6	BiConiLog Antenna (26-3000MHz)	ETS-LINDGREN	3142C	SEL0015	03-04-2007	02-04-2008
7	EMI Test Receiver	Rohde & Schwarz	ESCI	SEL0022	27-06-2007	26-06-2008
8	Active Loop Antenna	Beijing Daze	ZN30900A	SEL0097	15-06-2007	14-06-2008

5.2 E.U.T. Operation

Input voltage: 12V DC
Operating Environment:
Temperature: 24.0 °C
Humidity: 52 % RH
Atmospheric Pressure: 1012 mbar
EUT Operation: Test in transmitting mode:
1. Operation frequency: 2.414GHz.



5.3 Test Procedure & Measurement Data

5.3.1 Radiated Emissions

5.3.1.1 Test in transmitting mode

Test Requirement: FCC Part15 C
Test Method: Based on FCC Part15 C Section 15.249
Test Date: 18 October 2007
Measurement Distance: 3m (Semi-Anechoic Chamber)
Frequency range: 30 MHz – 10GHz for transmitting mode.
Test instrumentation resolution bandwidth: 120 kHz (30 MHz - 1000 MHz), 1 MHz (1000 M – 25GHz)
Operation: Receive antenna scan height 1 - 4 m, polarization Vertical/ Horizontal

Requirements:

Table with 3 columns: Fundamental Frequency (MHz), Field Strength of Fundamental (dBuV/m @ 3m), Field Strength of Harmonics and Spurious Emissions (dBuV/m @ 3m). Rows include frequency ranges like 902 to 928, 2400 to 2483.5, 5725 to 5875, and 24000 to 24250.

The fundamental frequency of the EUT is 2.414GHz

The limit for average field strength dBuV/m for the fundamental frequency = 94.0 dBuV/m.

No fundamental is allowed in the restricted bands.

The limit for average field strength dBuV/m for the harmonics and spurious frequencies = 54.0 dBuV/m. Spurious in the restricted bands must be less than 54.0 dBuV/m or 15.209.

Test Procedure: The procedure used was ANSI Standard C63.4-2003. The receive was scanned from 30MHz to 25GHz. When an emission was found, the table was rotated to produce the maximum signal strength. An initial pre-scan was performed for in peak detection mode using the receiver. The EUT was measured for both the Horizontal and Vertical polarities and performed a pre-test three orthogonal planes. For intentional radiators, measurements of the variation of the input power or the radiated signal level of the fundamental frequency component of the emission, as appropriate, shall be performed with the supply voltage varied between 85% and 115% of the nominal rated supply voltage. The worst case emissions were reported.

Test Configuration:

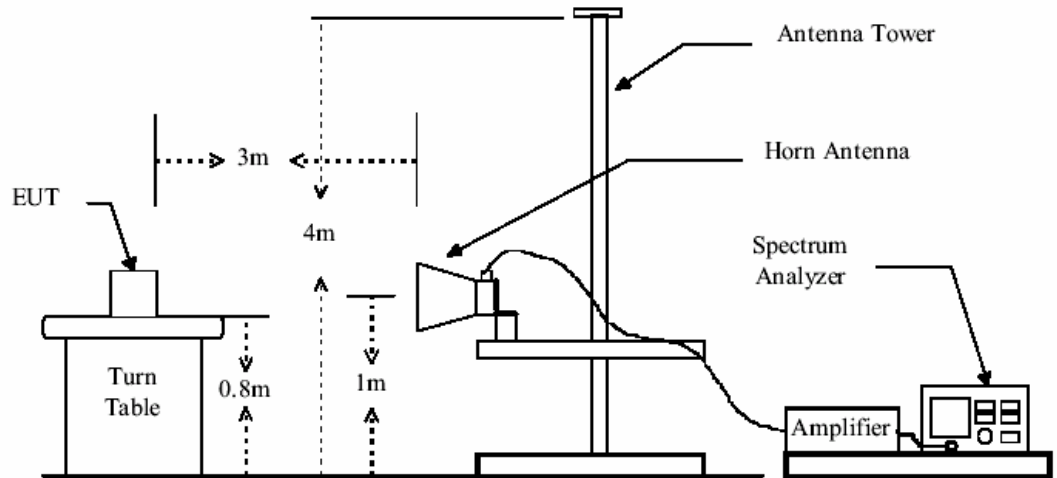
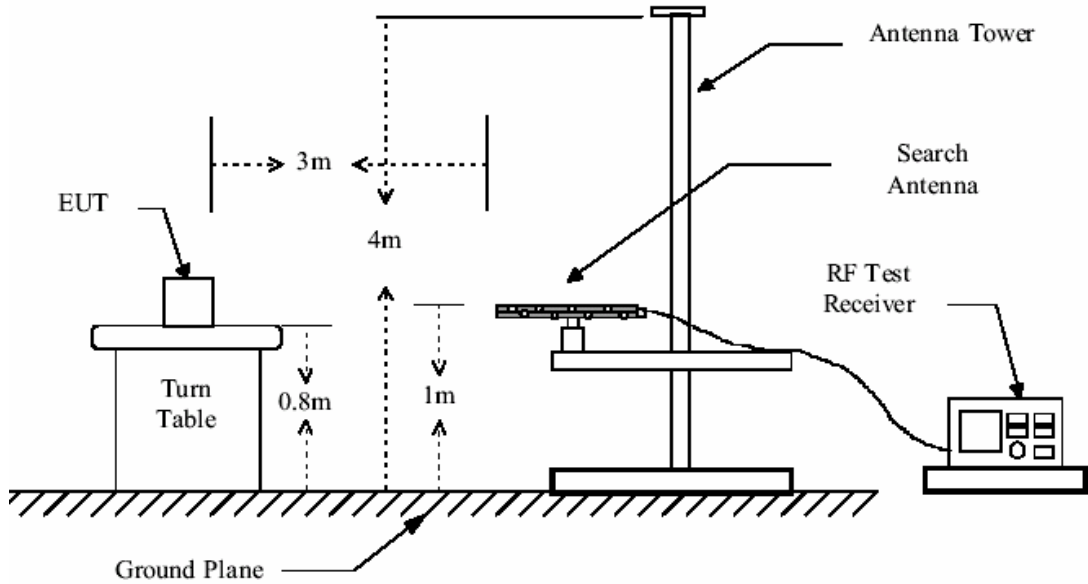



The field strength is calculated by adding the Antenna Factor, Cable Factor & Peramplifier . The basic equation with a sample calculation is as follows:

Final Test Level =Receiver Reading + Antenna Factor + Cable Factor – Peramlifer Factor

The following test results were performed on the EUT:

. Fundamental emission

Remark: Duty cycle of the EUT is 100%.

Peak Measurement

Test Frequency (GHz)	Measuring Level (dBuV/m)		Limits (dBuV/m)	Margin (dB)	
	Vertical	Horizontal		Vertical	Horizontal
2.414	92.5	89.8	114.0	21.5	24.5
Average Measurement					
2.414	72.8	70.5	94.0	21.2	23.5

(2). Harmonics & Spurious Emissions

The following test results were performed on the comple system at 30MHz-1000MHz.

Test Frequency (GHz)	Measuring Level (dBuV/m)		Limits (dBuV/m)	Margin (dB)	
	Vertical	Horizontal		Vertical	Horizontal
32.91	11.96	10.67	40	28.04	29.33
97.90	9.36	10.78	43.5	34.14	32.72
229.82	21.20	11.91	46	24.80	34.09
375.32	17.16	15.65	46	28.84	30.35
540.22	19.64	20.80	46	26.36	25.20
783.69	28.89	23.31	46	17.11	22.69

The following test results were performed at above 1 GHz.

Test Frequency (GHz)	Measuring Level (dBuV/m)		Measuring Level (dBuV/m)	Margin (dB)		Remark
	Vertical	Horizontal		Vertical	Horizontal	
4.8728	69.54	66.66	74.0	4.46	7.34	Peak
4.8728	50.25	47.15	54.0	3.75	6.85	Average
7.44660	44.08	46.44	54.0	9.92	7.56	Peak
10.5210	43.91	44.31	54.0	10.09	9.69	Peak
12.6230	44.73	47.16	54.0	9.27	6.84	Peak
15.1710	44.90	48.50	54.0	9.10	5.50	Peak
17.3920	48.85	47.39	54.0	5.15	6.61	Peak



SGS-CSTC Standards Technical Services Ltd.

Report No.: SZEMO071002782RFI

Page: 10 of 13

Remark:

- 1). According to 15.249 (e) As shown in Section 15.35(b), for frequencies above 1000 MHz, the above field strength limits are based on average limits. However, the peak field strength of any emission shall not exceed the maximum permitted average limits specified above by more than 20 dB under any condition of modulation.

TEST RESULTS: The unit does meet the FCC requirements.



5.3.2 Occupied Bandwidth & Band Edge

Test Requirement: FCC Part 15 C
 Test Method: Based on FCC Part15 C Section 15.249:
 Operation within the band 2.4000 – 2.4835GHz

Test Date: 15 October 2007

Requirements: 15.249 (d) Emissions radiated outside of the specified frequency bands, except for harmonics, shall be attenuated by at least 50 dB below the level of the fundamental or to the general radiated emission limits in Section 15.209, whichever is the lesser attenuation.

Method of measurement: A small sample of the transmitter output was fed into the Spectrum Analyzer and the attached plot was taken. The vertical is set to 10dB per division. The horizontal scale is set to 3MHz per division.

The occupied bandwidth as below:

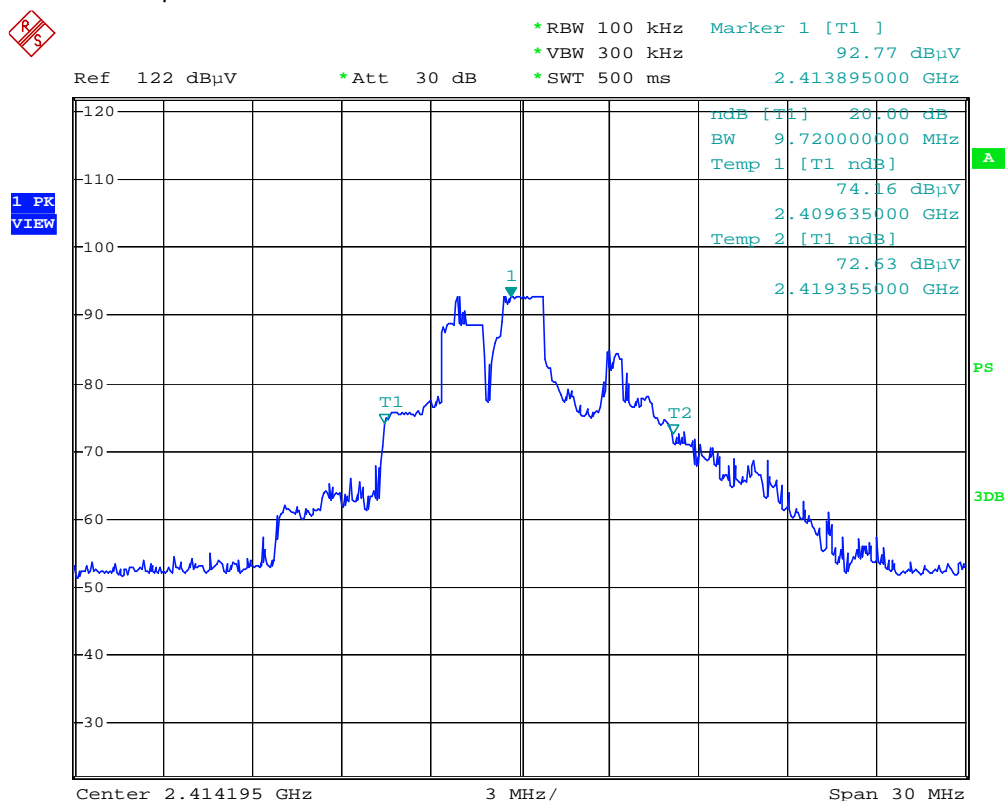

N

Date: 15.OCT.2007 12:02:30



(2). 2.4GHz Band Edge:



Delta 1 [T1]	RBW	100 kHz	RF Att	20 dB
Ref Lvl	-50.42 dB	VBW	100 kHz	
117 dB μ V	-13.38677355 MHz	SWT	1 s	Unit dB μ V

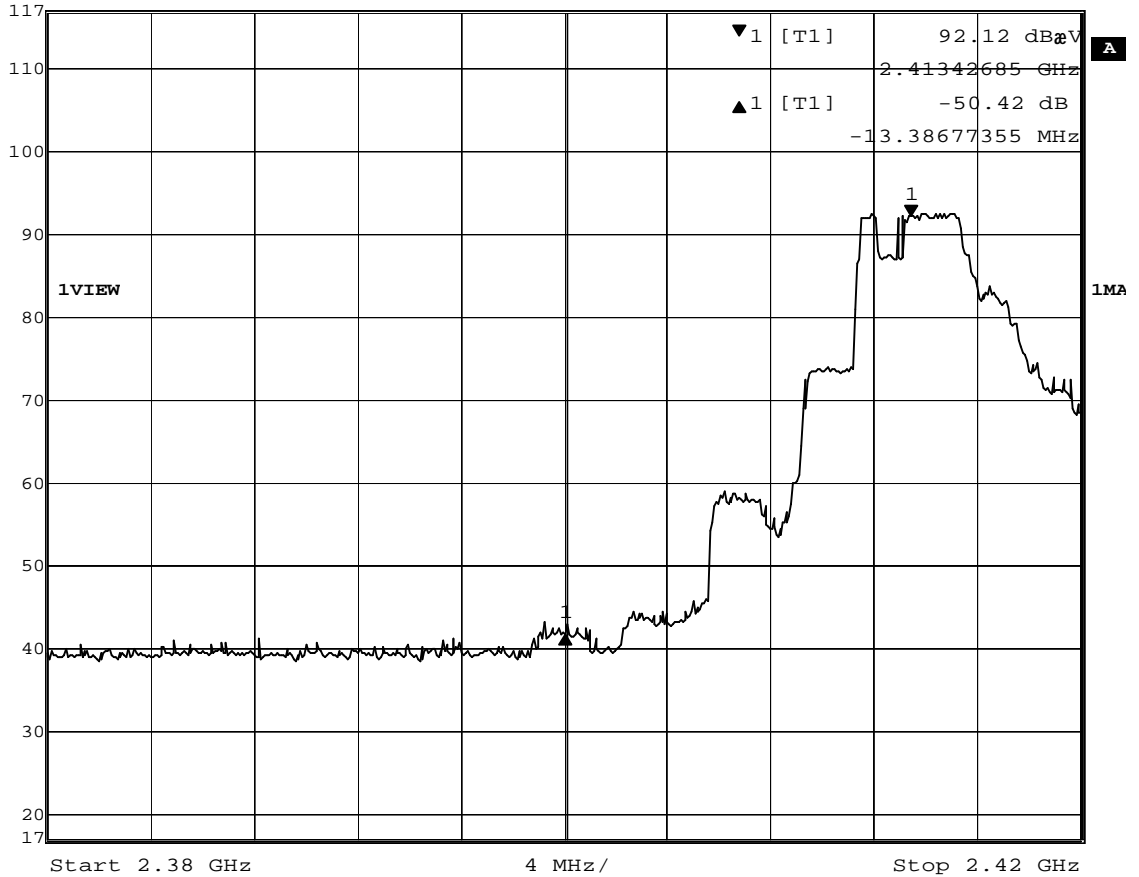

Date: 15.OCT.2007 12:31:32

For the field strength of Lower Edges:2.4000GHz is 42.5dBuV/m.

The results: The unit does meet the FCC requirements.



(2). 2.4835GHz Band Edge:

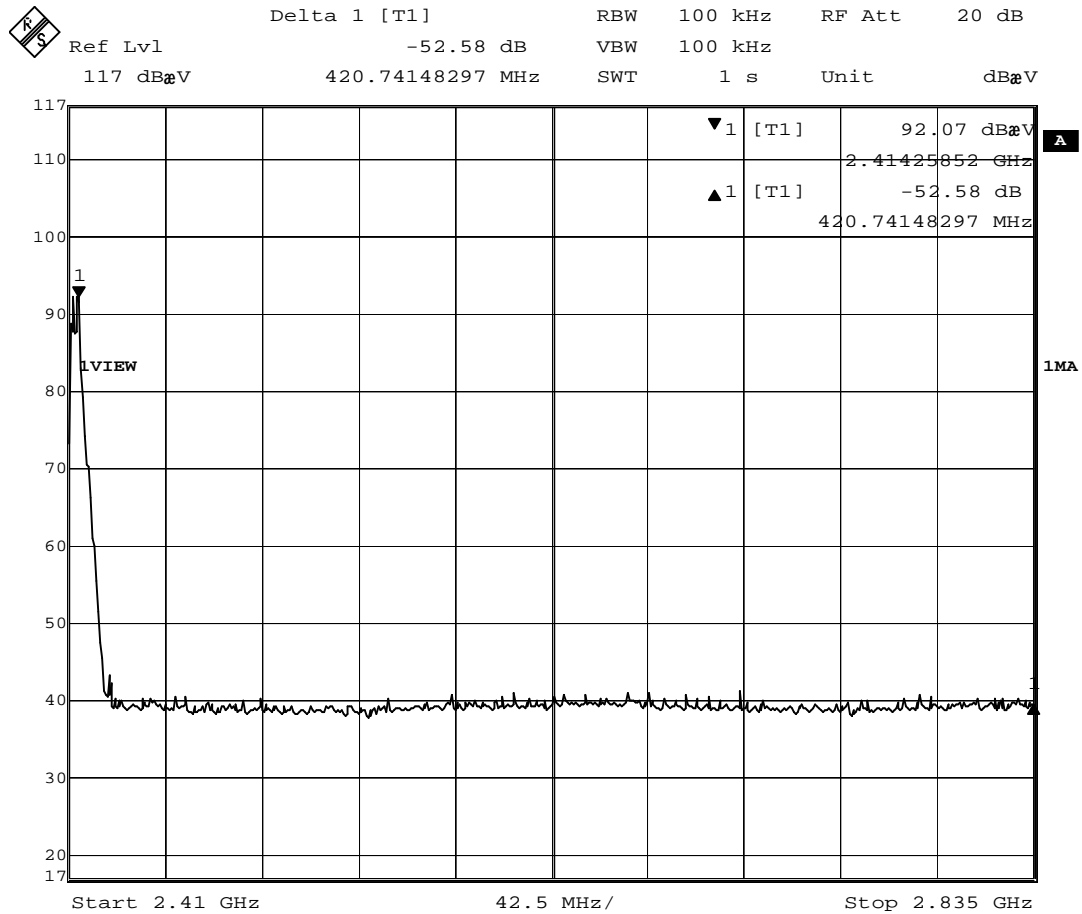

Date: 15.OCT.2007 12:33:13

For the field strength of Upper Edges:2.4835GHz is less than 39.9dBuV/m.

The results: The unit does meet the FCC requirements.