



# FCC DFS TEST REPORT

**Issued Date** : Jun. 11, 2013  
**Project No.** : 1305C141  
**Equipment** : nabi Tablet (nabi XD)  
**Model Name** : NABIXD-NV10C; NABIXD-NV10B  
**Applicant** : Foxconn International Inc.  
**Address** : No.2, Ziyou St., Tucheng Dist., New Taipei City 236,  
: Taiwan  
**Manufacturer** : FUHU INC  
**Address** : 909 N SEPULVEDA BLVD STE 540 EL SEGUNDO, CA  
90245-2733

**Tested by:**

Neutron Engineering Inc. EMC Laboratory

**Date of Receipt:** May. 21, 2013

**Date of Test:**

May. 21, 2013 ~ Jun. 10, 2013

Testing Engineer : David Mao

(David Mao)

Technical Manager : Leo Hung

(Leo Hung)

Authorized Signatory : Steven Lu

(Steven Lu)

## **NEUTRON ENGINEERING INC.**

No.3, Jinshagang 1st Road, ShiXia, Dalang Town,  
Dong Guan, China.523792

**TEL : +86-769-8318-3000 FAX : +86-769-8319-6000**



**Declaration**

**Neutron** represents to the client that testing is done in accordance with standard procedures as applicable and that test instruments used has been calibrated with the standards traceable to National Measurement Laboratory (**NML**) of **R.O.C.**, or National Institute of Standards and Technology (**NIST**) of **U.S.A.**

**Neutron's** reports apply only to the specific samples tested under conditions. It is manufacture's responsibility to ensure that additional production units of this model are manufactured with the identical electrical and mechanical components. **Neutron** shall have no liability for any declarations, inferences or generalizations drawn by the client or others from **Neutron** issued reports.

**Neutron's** reports must not be used by the client to claim product endorsement by the authorities or any agency of the Government.

This report is the confidential property of the client. As a mutual protection to the clients, the public and **Neutron-self**, extracts from the test report shall not be reproduced except in full with **Neutron's** authorized written approval.

**Neutron's** laboratory quality assurance procedures are in compliance with the **ISO Guide 17025** requirements, and accredited by the conformity assessment authorities listed in this test report.

**Limitation**

For the use of the authority's logo is limited unless the Test Standard(s)/Scope(s)/Item(s) mentioned in this test report is (are) included in the conformity assessment authorities acceptance respective.



<b>Table of Contents</b>	<b>Page</b>
<b>1 . CERTIFICATION</b>	<b>4</b>
<b>2 . EUT INFORMATION</b>	<b>5</b>
2.1 EUT SPECIFICATION TABLE	5
2.4 EUT MAXIMUM AND MINIMUM E.I.R.P. POWER	7
<b>3 . U-NII DFS RULE REQUIREMENTS</b>	<b>8</b>
3.1 WORKING MODES AND REQUIRED TEST ITEMS	8
3.2 TEST LIMITS AND RADAR SIGNAL PARAMETERS	9
<b>4 . TEST INSTRUMENTS</b>	<b>11</b>
<b>5 . EMC EMISSION TEST</b>	<b>12</b>
5.1 DFS MEASUREMENT SYSTEM:	12
5.2 CALIBRATION OF DFS DETECTION THRESHOLD LEVEL:	14
5.3 DEVIATION FROM TEST STANDARD	14
<b>6 . TEST RESULTS</b>	<b>15</b>
6.1 SUMMARY OF TEST RESULT	15
6.2.1 TEST MODE: DEVICE OPERATING IN SLAVE MODE.	16
6.2.2 DFS DETECTION THRESHOLD	16
6.2.3 CHANNEL CLOSING TRANSMISSION AND CHANNEL MOVE TIME WLAN TRAFFIC	20
<b>7. TEST SETUP PHOTOS</b>	<b>32</b>



## 1. CERTIFICATION

Equipment : nabi Tablet (nabi XD)  
Trade Name : nabi  
Model Name. : NABIXD-NV10C; NABIXD-NV10B  
Applicant : Foxconn International Inc.  
Factory : Honfujin precision industry(Chongqing) Co.,Ltd.  
Address : No.1,East district 1st Rd.Shapingba District,ChongQing  
Date of Test: : May. 21, 2013 ~ Jun. 10, 2013  
Test Item : ENGINEERING SAMPLE  
Standards : FCC Part 15, Subpart E (Section 15.407) FCC 06-96

The above equipment has been tested and found compliance with the requirement of the relative standards by Neutron Engineering Inc. EMC Laboratory.

The test data, data evaluation, and equipment configuration contained in our test report (Ref No. NEI-FCCP-6-1305C141) were obtained utilizing the test procedures, test instruments, test sites that has been accredited by the Authority of TAF according to the ISO-17025 quality assessment standard and technical standard(s).



## 2. EUT INFORMATION

### 2.1 EUT SPECIFICATION TABLE

Table 1: Specification of EUT

<b>Product name</b>	nabi Tablet (nabi XD)
<b>Brand Name</b>	nabi
<b>Model</b>	NABIXD-NV10C; NABIXD-NV10B
<b>FCC ID</b>	SIB-NABIXD-NV10B
<b>Software Version</b>	
<b>Firmware Version</b>	
<b>Operational Mode</b>	Slave
<b>Operating Frequency Range</b>	5250~5350&5470~5725
<b>Modulation</b>	OFDM

**Note:** This device was functioned as a  Master  Slave device without during the DFS

### 2.2 DESCRIPTION OF AVAILABLE ANTENNAS TO THE EUT

Table 2: Antenna list.

Ant.	Manufacturer	Model Name	Antenna Type / Connector	Gain (dBi)
1	晶鈦	AH-JT-0215Y0311	Internal Antenna	3.97



**2.3 CONDUCTED OUTPUT POWER AND EIRP POWER**

TABLE 3: THE CONDUCTED OUTPUT POWER LIST

TX (11a)

FREQUENCY BAND (MHz)	MAX. POWER	
	OUTPUT POWER(dBm)	OUTPUT POWER(mW)
5150~5250	13.50	22.38721
5250~5350	13.81	24.04363
5745~5825	11.65	14.62177

TX (11n 40M)

FREQUENCY BAND (MHz)	MAX. POWER	
	OUTPUT POWER(dBm)	OUTPUT POWER(mW)
5150~5250	13.26	21.18361
5250~5350	13.63	23.06747
5745~5825	11.42	13.86756



**2.4 EUT MAXIMUM AND MINIMUM E.I.R.P. POWER**

TABLE 4: THE MAX EIRP LIST

TX (11a)

FREQUENCY BAND (MHz)	MAX. POWER	
	OUTPUT POWER(dBm)	OUTPUT POWER(mW)
5150~5250	17.47	55.84702
5250~5350	17.78	59.97911
5745~5825	15.62	36.47539

TX (11n 40M)

FREQUENCY BAND (MHz)	MAX. POWER	
	OUTPUT POWER(dBm)	OUTPUT POWER(mW)
5150~5250	17.23	52.84453
5250~5350	17.60	57.54399
5745~5825	15.39	34.59394



### 3. U-NII DFS RULE REQUIREMENTS

#### 3.1 WORKING MODES AND REQUIRED TEST ITEMS

The manufacturer shall state whether the UUT is capable of operating as a Master and/or a Client. If the UUT is capable of operating in more than one operating mode then each operating mode shall be tested separately. See tables 1 and 2 for the applicability of DFS requirements for each of the operational modes.

Table 5: Applicability of DFS requirements prior to use a channel

Requirement	Operational Mode		
	Master	Client without radar detection	Client with radar detection
Non-Occupancy Period	✓	Not required	✓
DFS Detection Threshold	✓	Not required	✓
Channel Availability Check Time	✓	Not required	Not required
Uniform Spreading	✓	Not required	Not required
U-NII Detection Bandwidth	✓	Not required	✓

Table 6: Applicability of DFS requirements during normal operation.

Requirement	Operational Mode		
	Master	Client without radar detection	Client with radar detection
DFS Detection Threshold	✓	Not required	✓
Channel Closing Transmission Time	✓	✓	✓
Channel Move Time	✓	✓	✓
U-NII Detection Bandwidth	✓	Not required	✓





**3.2 TEST LIMITS AND RADAR SIGNAL PARAMETERS**

**DETECTION THRESHOLD VALUES**

Table 7: DFS Detection Thresholds for Master Devices and Client Devices With Radar Detection.

Maximum Transmit Power	Value (See Notes 1 and 2)
≥ 200 milliwatt	-64 dBm
< 200 milliwatt	-62 dBm

Note 1: This is the level at the input of the receiver assuming a 0 dBi receive antenna.

Note 2: Throughout these test procedures an additional 1 dB has been added to the amplitude of the test transmission waveforms to account for variations in measurement equipment. This will ensure that the test signal is at or above the detection threshold level to trigger a DFS response.

Table 8: DFS Response Requirement Values

Parameter	Value
Non-occupancy period	Minimum 30 minutes
Channel Availability Check Time	60 seconds
Channel Move Time	10 seconds See Note 1.
Channel Closing Transmission Time	200 milliseconds + an aggregate of 60 milliseconds over remaining 10 second period. See Notes 1 and 2.
U-NII Detection Bandwidth	Minimum 80% of the UNII 99% transmission power bandwidth. See Note 3.

**Note 1:** The instant that the Channel Move Time and the Channel Closing Transmission Time begins is as follows:

- For the Short Pulse Radar Test Signals this instant is the end of the Burst.
- For the Frequency Hopping radar Test Signal, this instant is the end of the last radar Burst generated.
- For the Long Pulse Radar Test Signal this instant is the end of the 12 second period defining the Radar Waveform.

**Note 2:** The Channel Closing Transmission Time is comprised of 200 milliseconds starting at the beginning of the Channel Move Time plus any additional intermittent control signals required to facilitate a Channel move (an aggregate of 60 milliseconds) during the remainder of the 10 second period. The aggregate duration of control signals will not count quiet periods in between transmissions.

**Note 3:** During the U-NII Detection Bandwidth detection test, radar type 1 is used and for each frequency step the minimum percentage of detection is 90 percent. Measurements are performed with no data traffic.



**PARAMETERS OF DFS TEST SIGNALS**

Step intervals of 0.1 microsecond for Pulse Width, 1 microsecond for PRI, 1 MHz for chirp width and 1 for the number of pulses will be utilized for the random determination of specific test waveforms.

Table 9: Short Pulse Radar Test Waveforms.

Radar Type	Pulse Width (μsec)	PRI (μsec)	Number of Pulses	Minimum Percentage of Successful Detection	Minimum Number of Trials
1	1	1428	18	60%	30
2	1-5	150-230	23-29	60%	30
3	6-10	200-500	16-18	60%	30
4	11-20	200-500	12-16	60%	30
Aggregate (Radar Types 1-4)				80%	120

Table 10: Long Pulse Radar Test Waveform

Radar Type	Pulse Width (μsec)	Chirp Width (MHz)	PRI (μsec)	Number of Pulses per Burst	Number of Bursts	Minimum Percentage of Successful Detection	Minimum Number of Trials
5	50-100	5-20	1000-2000	1-3	8-20	80%	30

Table 11: Frequency Hopping Radar Test Waveform

Radar Type	Pulse Width (μsec)	Chirp Width (MHz)	PRI (μsec)	Number of Pulses per Burst	Number of Bursts	Minimum Percentage of Successful Detection	Minimum Number of Trials
6	1	333	9	0.333	300	70%	30



**4. TEST INSTRUMENTS**

Table 1: Test instruments list.

DESCRIPTION	MANUFACTURER	MODEL NO.	Serial No	Calibration Until
EXA Specturm Analyzer	Agilent	N9010A	MY50520044	2014-04-25
Signal Generator	Agilent	E4438C	My49071316	2014-04-25
POWER SPLITTER	Mini-Circuits	ZFRSC-123-S+	331000910	2014-04-25
POWER SPLITTER	Mini-Circuits	ZN4PD1-63-S+	SF933501045	2014-04-25
POWER SPLITTER	Mini-Circuits	ZN2PD-9G-S+	SF012700714	2014-04-25
attenuator	Mini-Circuits	VAT-30+	30912	2014-04-25
attenuator	Mini-Circuits	VAT-10+	30909	2014-04-25
Specturm Analyzer	R&S	FSL6	1004423	2013-11-25
PC	Dell 745	DCSM	G7K832X	--
Netbook	Hp	HSTNN-I69C-3	CNU02203XG	--

Note: Calibration interval of instruments listed above is one year.

## 5. EMC EMISSION TEST

### 5.1 DFS MEASUREMENT SYSTEM:

#### Slave without Radar Detection Conducted Measurement

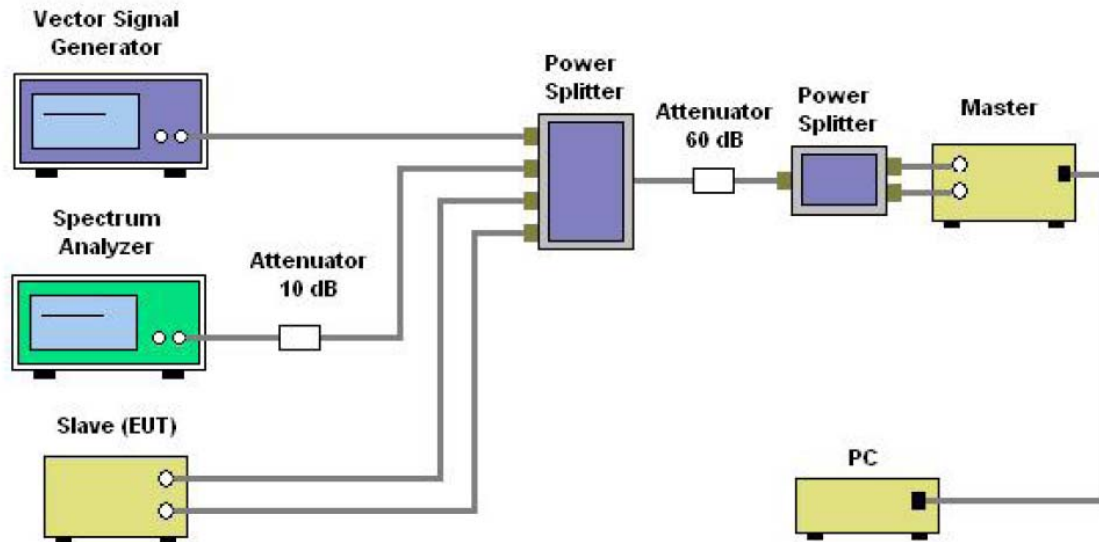

#### SYSTEM OVERVIEW

The short pulse and long pulse signal generating system utilizes the NTIA software. The Vector Signal Generator has been validated by the NTIA. The hopping signal generating system utilizes the CCS simulated hopping method and system, which has been validated by the DoD, FCC and NTIA. The software selects waveform parameters from within the bounds of the signal type on a random basis using uniform distribution.

The short pulse types 2, 3 and 4, and the long pulse type 5 parameters are randomized at run-time.



The hopping type 6 pulse parameters are fixed while the hopping sequence is based on the August 2005 NTIA Hopping Frequency List. The initial starting point randomized at run-time and each subsequent starting point is incremented by 475. Each frequency in the 100-length segment is compared to the boundaries of the EUT Detection Bandwidth and the software creates a hopping burst pattern in accordance with Section 7.4.1.3 Method #2 Simulated Frequency Hopping Radar Waveform Generating Subsystem of FCC 06-96. The frequency of the signal generator is incremented in 1 MHz steps from FL to FH for each successive trial. This incremental sequence is repeated as required to generate a minimum of 30 total trials and to maintain a uniform frequency distribution over the entire Detection Bandwidth.

The signal monitoring equipment consists of a spectrum analyzer set to display 8001 bins on the horizontal axis. The time-domain resolution is 2 msec / bin with a 16 second sweep time, meeting the 10 second short pulse reporting criteria. The aggregate ON time is calculated by multiplying the number of bins above a threshold during a particular observation period by the dwell time per bin, with the analyzer set to peak detection and max hold.

Should multiple RF ports be utilized for the Master and/or Slave devices (for example, for diversity or MIMO implementations), additional combiner/dividers are inserted between the Master Combiner/Divider and the pad connected to the Master Device (and/or between the Slave Combiner/Divider and the pad connected to the Slave Device). Additional pads are utilized such that there is one pad at each RF port on each EUT.



### 5.2 CALIBRATION OF DFS DETECTION THRESHOLD LEVEL:

A 50 ohm load is connected in place of the spectrum analyzer, and the spectrum analyzer is connected in place of the master device and the signal generator is set to CW mode. The amplitude of the signal generator is adjusted to yield a level of  $-62$  dBm as measured on the spectrum analyzer.

Without changing any of the instrument settings, the spectrum analyzer is reconnected to the Common port of the Spectrum Analyzer Combiner/Divider. Measure the amplitude and calculate the difference from  $-62$  dBm. Adjust the Reference Level Offset of the spectrum analyzer to this difference.

The spectrum analyzer displays the level of the signal generator as received at the antenna ports of the Master Device. The interference detection threshold may be varied from the calibrated value of  $-62$  dBm and the spectrum analyzer will still indicate the level as received by the Master Device.

Set the signal generator to produce a radar waveform, trigger a burst manually and measure the level on the spectrum analyzer. Readjust the amplitude of the signal generator as required so that the peak level of the waveform is at a displayed level equal to the required or desired interference detection threshold. Separate signal generator amplitude settings are determined as required for each radar type.

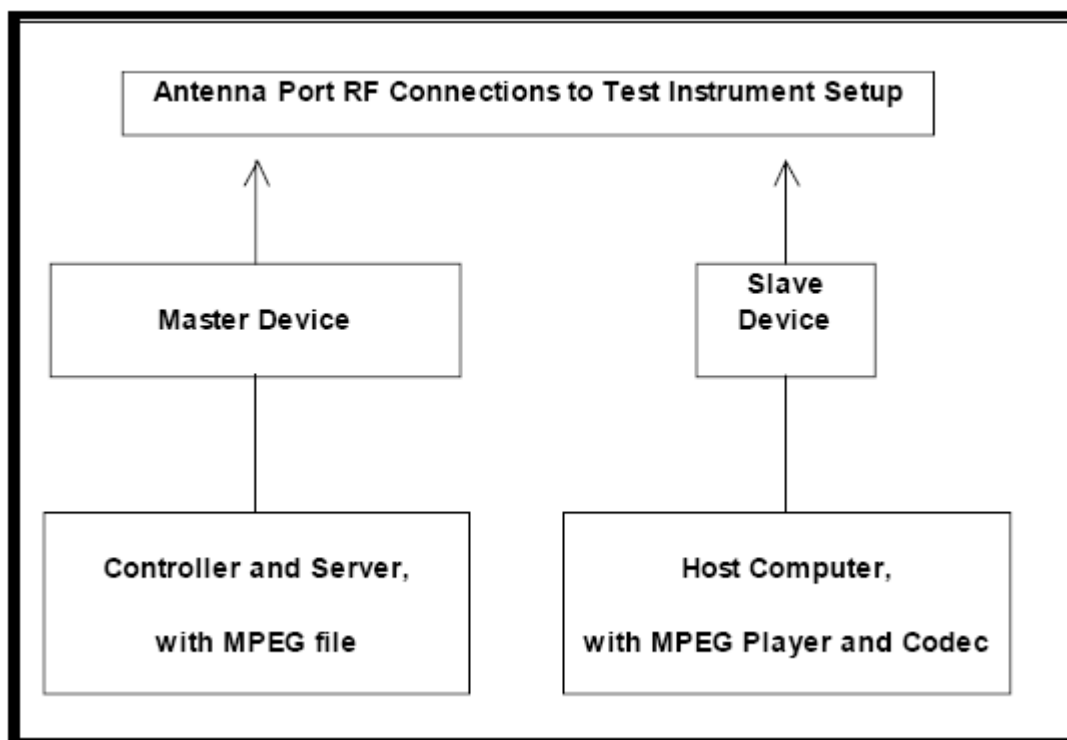

### 5.3 DEVIATION FROM TEST STANDARD

No deviation.



**6. TEST RESULTS**

**6.1 SUMMARY OF TEST RESULT**

<b>Clause</b>	<b>Test Parameter</b>	<b>Remarks</b>	<b>Pass/Fail</b>
15.407	DFS Detection Threshold	Applicable	N/A
15.407	Channel Availability Check Time	Not Applicable	N/A
15.407	Channel Move Time	Applicable	Pass
15.407	Channel Closing Transmission Time	Applicable	Pass
15.407	Non- Occupancy Period	Not Applicable	N/A
15.407	Uniform Spreading	Not Applicable	N/A
15.407	U-NII Detection Bandwidth	Not Applicable	N/A



**6.2.1 TEST MODE: DEVICE OPERATING IN SLAVE MODE.**

**6.2.2 DFS DETECTION THRESHOLD**

Calibration:

For a detection threshold level of -62dBm and the Master antenna gain is 3.97dBi, required detection threshold is -58.03 dBm (= -62+3.97).

Note: Maximum Transmit Power is less than 200 milliwatt in this report, so detection threshold level is -62dBm (please refer to Table 7 [page 8]).





### Radar Signal 1

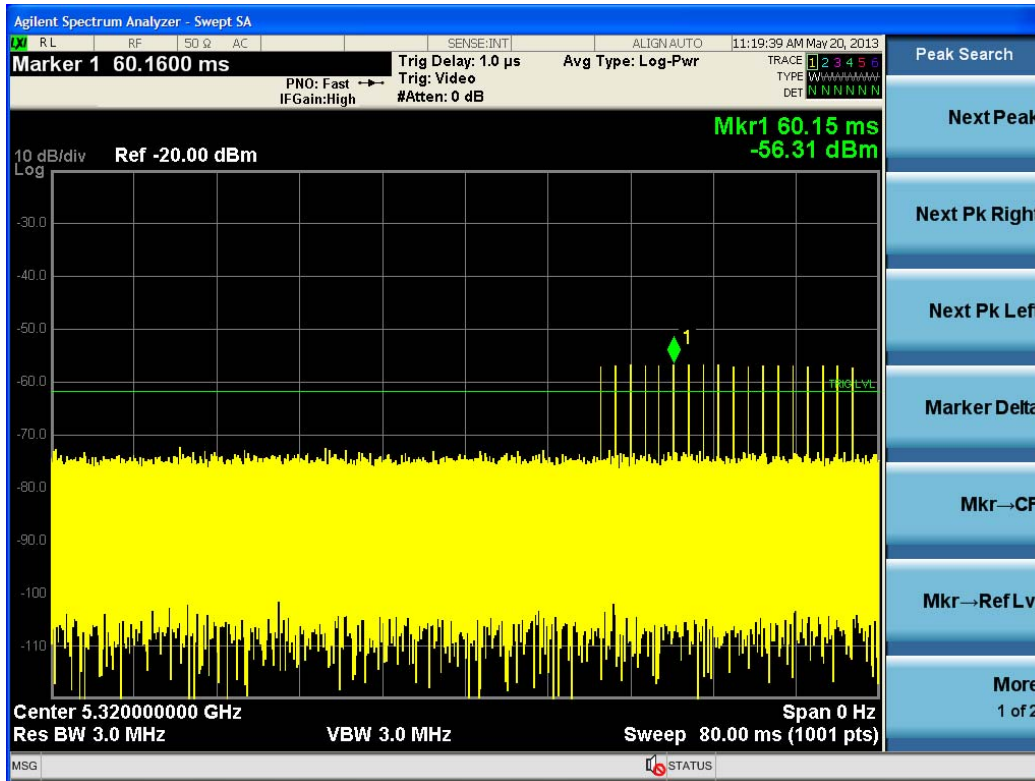

### Radar Signal 2

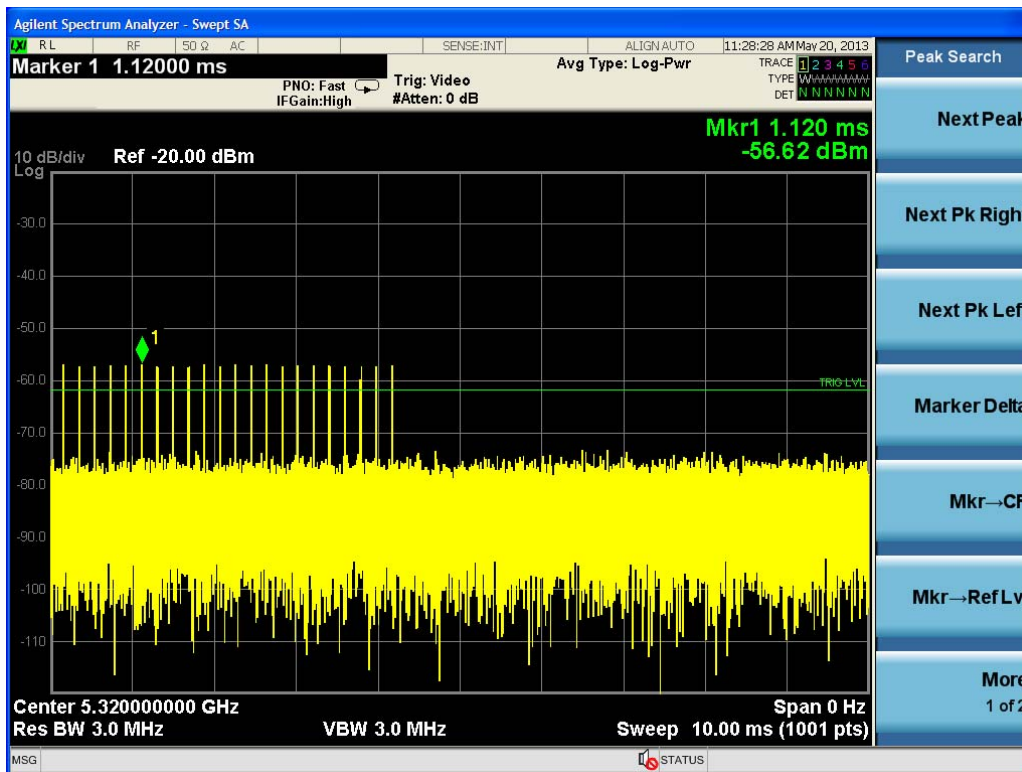



### Radar Signal 3

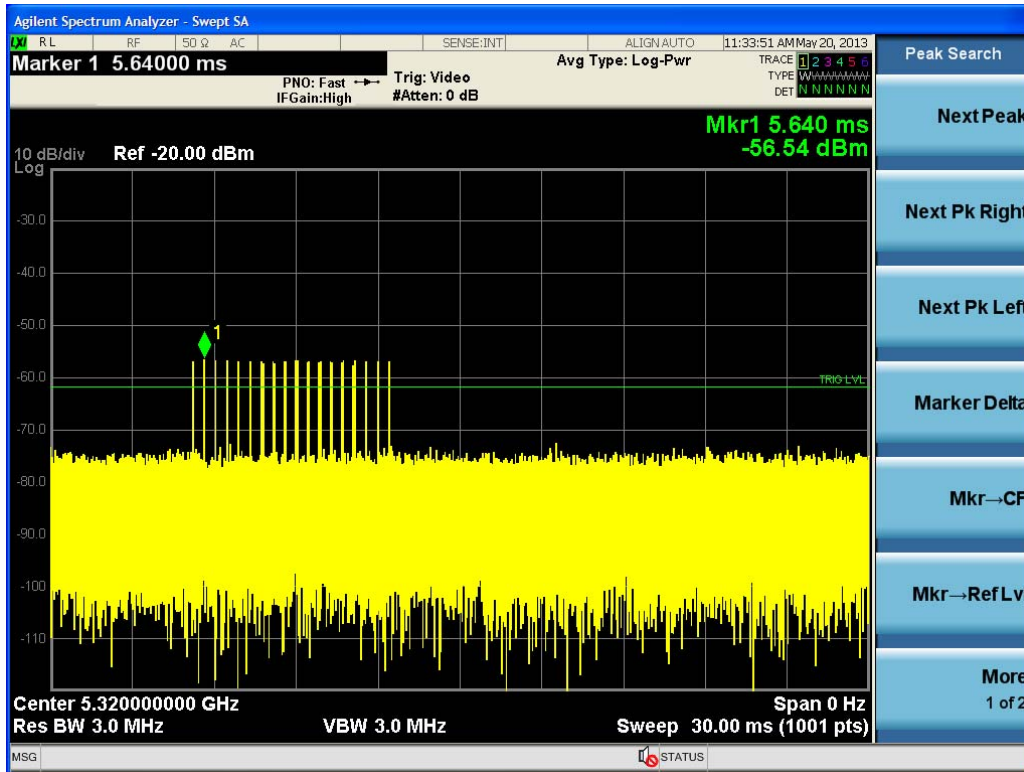

### Radar Signal 4

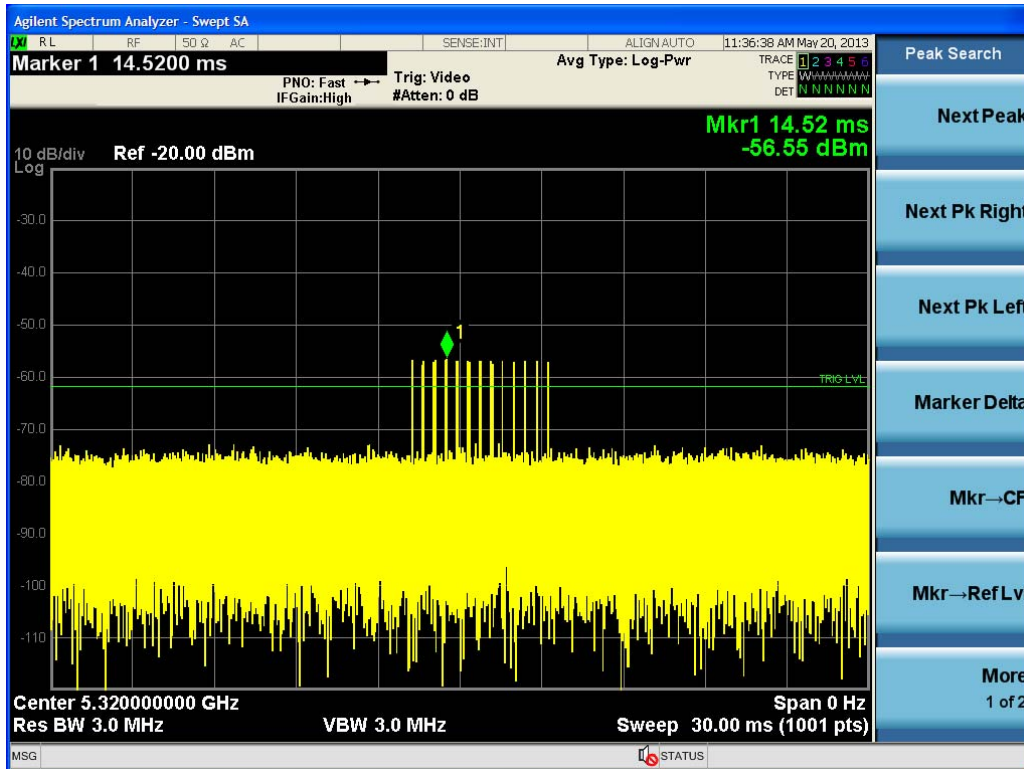



### Radar Signal 5

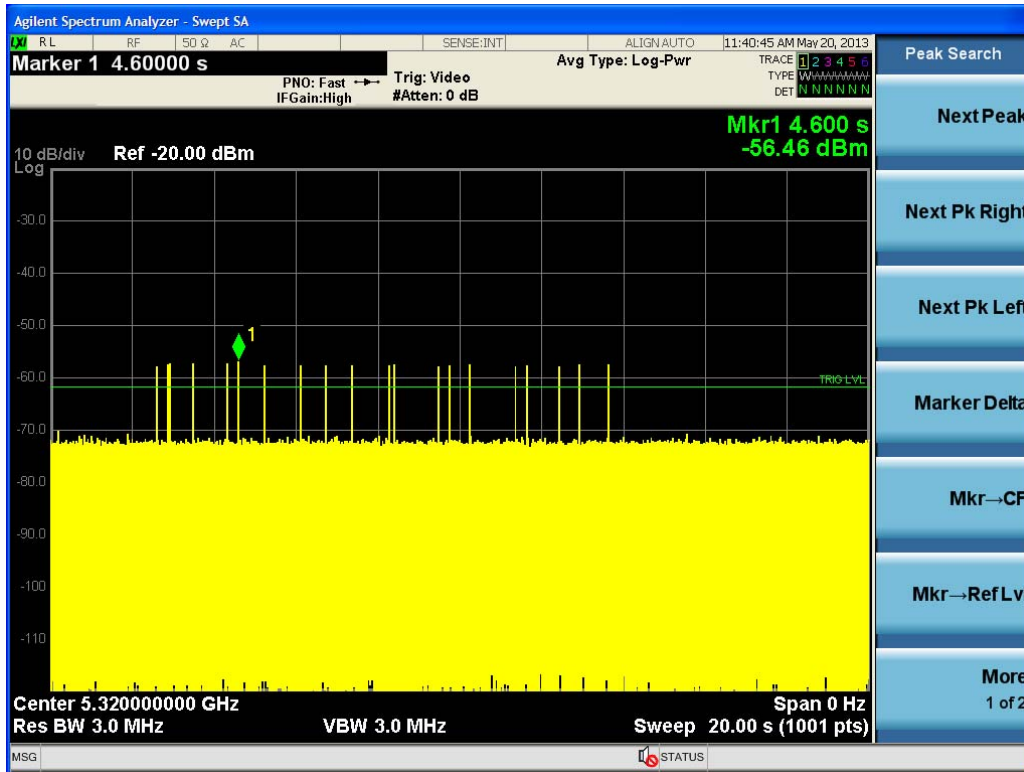

### Radar Signal 6

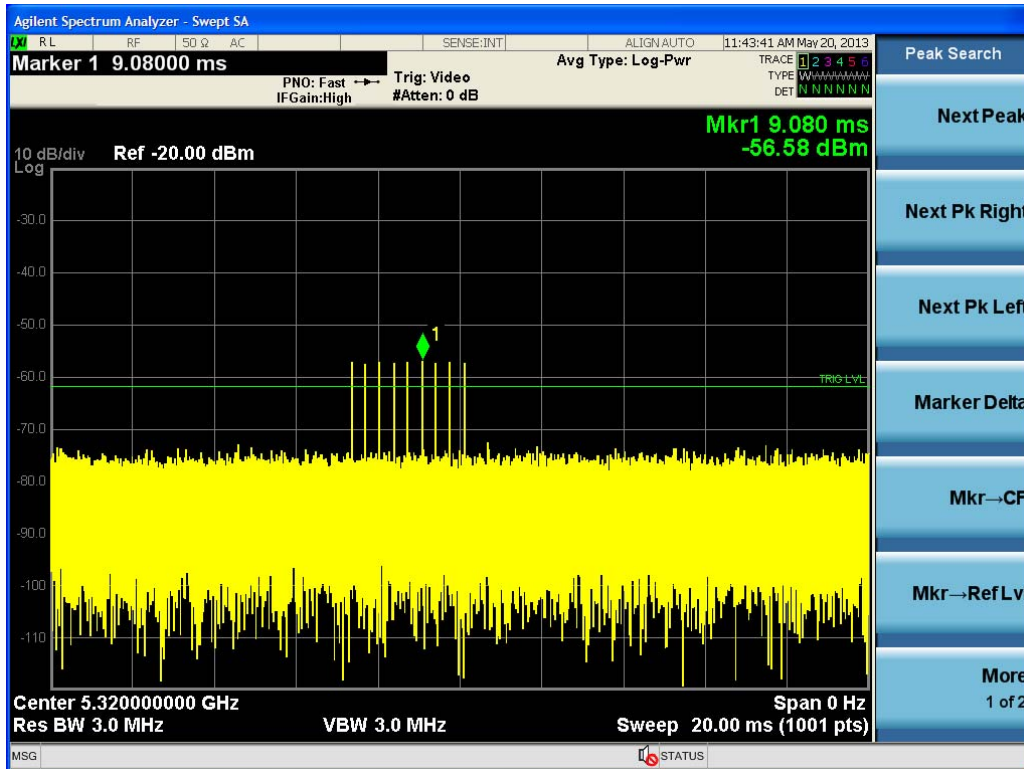



6.2.3 CHANNEL CLOSING TRANSMISSION AND CHANNEL MOVE TIME WLAN TRAFFIC TX (A Mode )

Radar signal 1

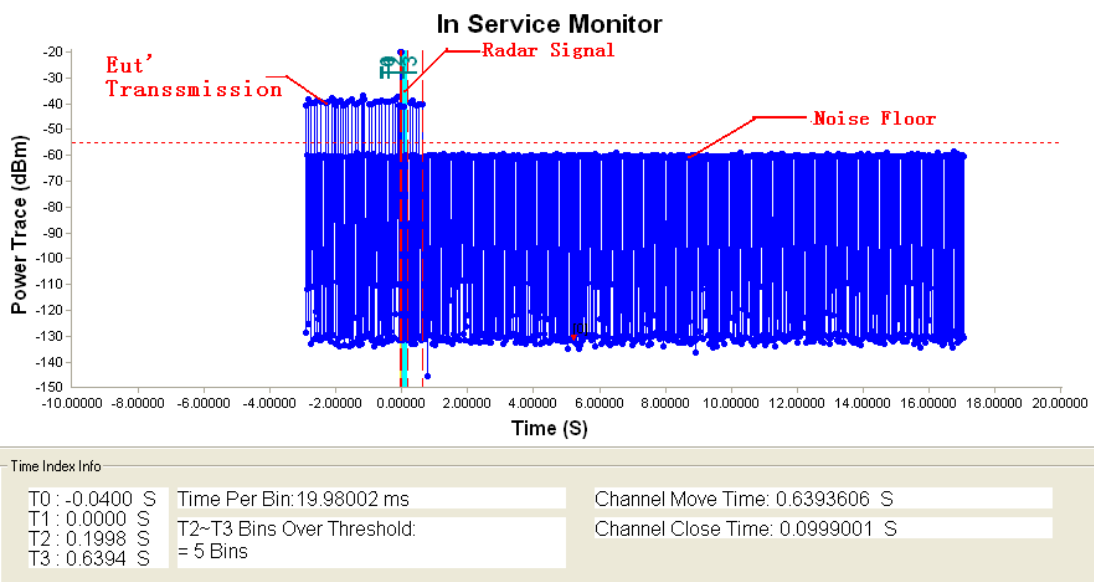

**Note:** T1 denotes the start of Channel Move Time upon the end of the last Radar burst.  
 T2 denotes the data transmission time of 200ms from T1.  
 T3 denotes the end of Channel Move Time.  
 T4 denotes the 10 second from T1 to observe the aggregate duration of transmissions.

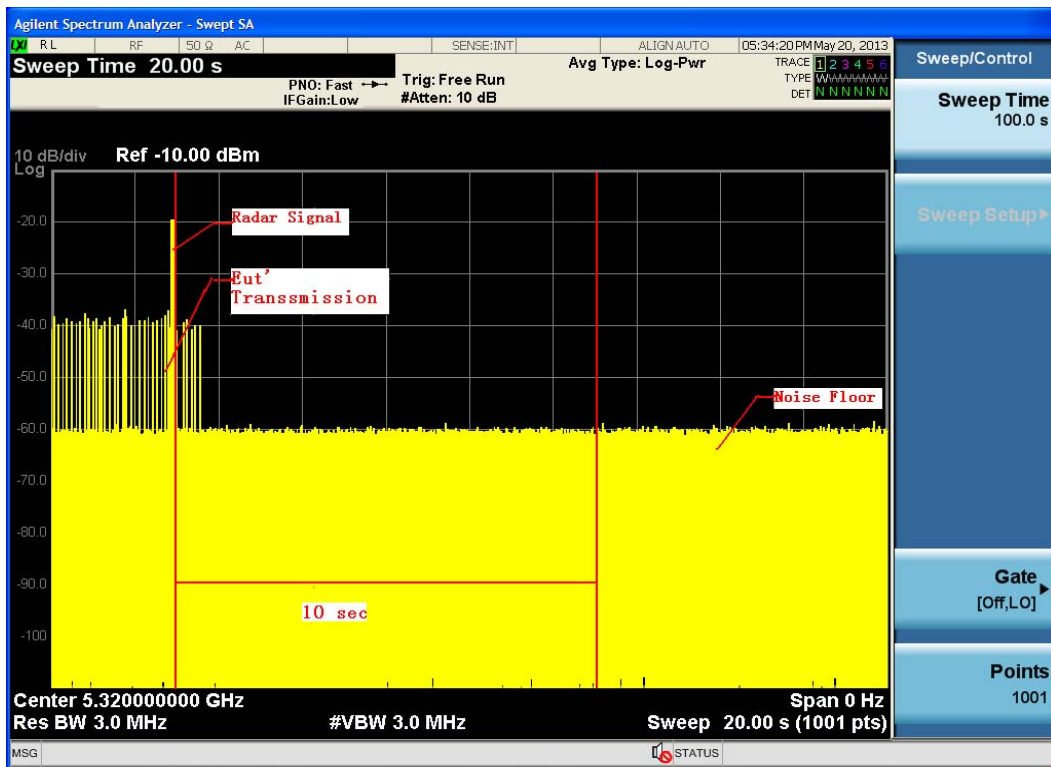

**Note:** An expanded plot for the device vacates the channel in the required 500ms



TX (A Mode )

Radar signal 2

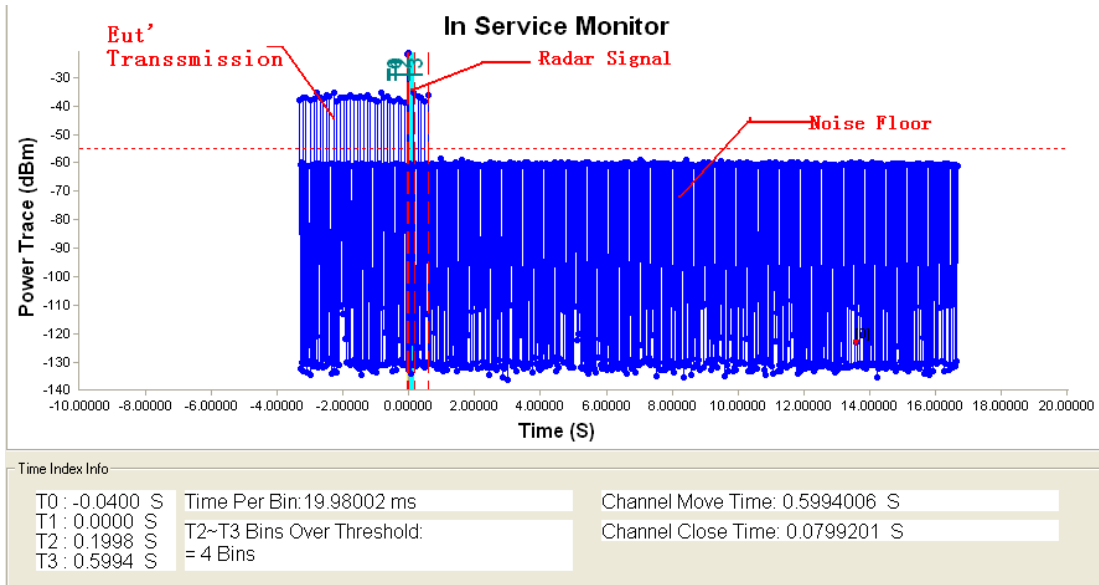

**Note:** T1 denotes the start of Channel Move Time upon the end of the last Radar burst.  
 T2 denotes the data transmission time of 200ms from T1.  
 T3 denotes the end of Channel Move Time.  
 T4 denotes the 10 second from T1 to observe the aggregate duration of transmissions.

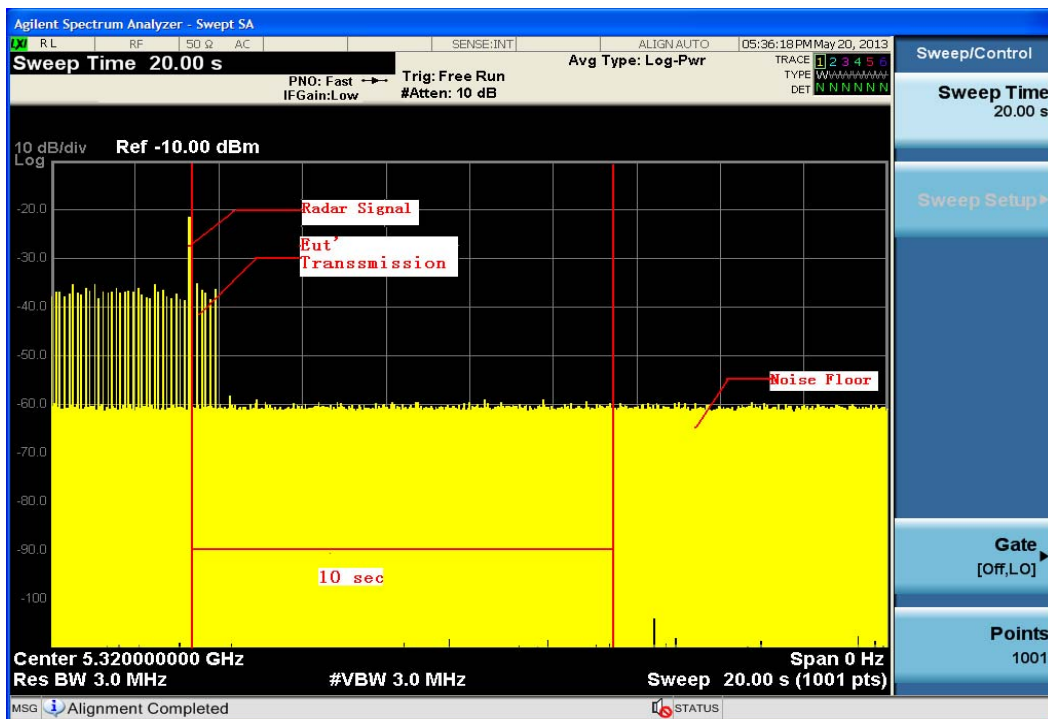

**Note:** An expanded plot for the device vacates the channel in the required 500ms



TX (A Mode )

Radar signal 3

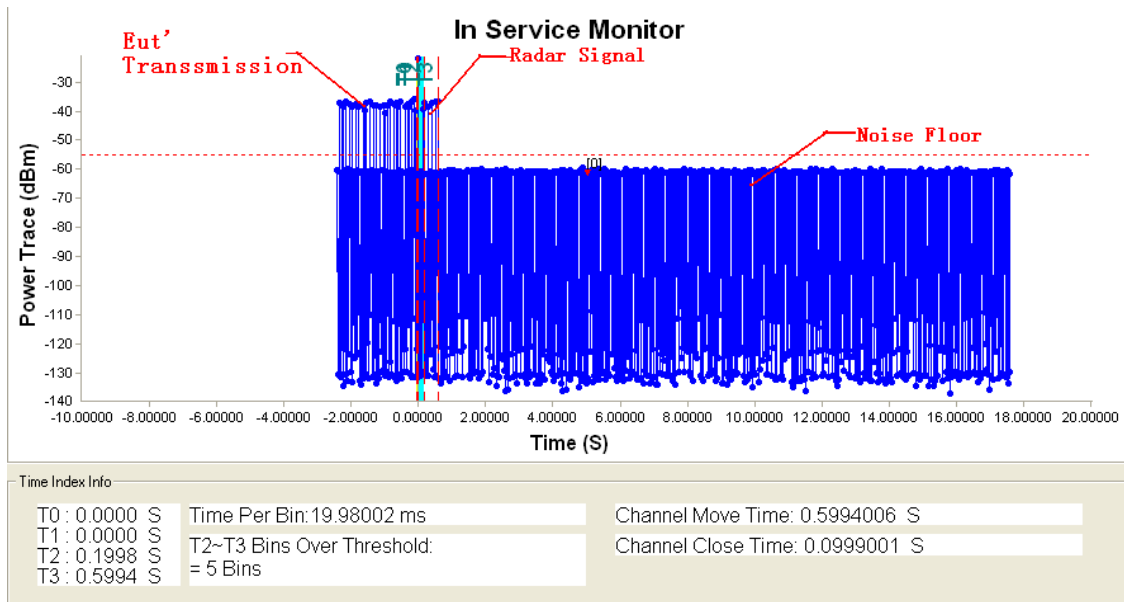

**Note:** T1 denotes the start of Channel Move Time upon the end of the last Radar burst.  
 T2 denotes the data transmission time of 200ms from T1.  
 T3 denotes the end of Channel Move Time.  
 T4 denotes the 10 second from T1 to observe the aggregate duration of transmissions.

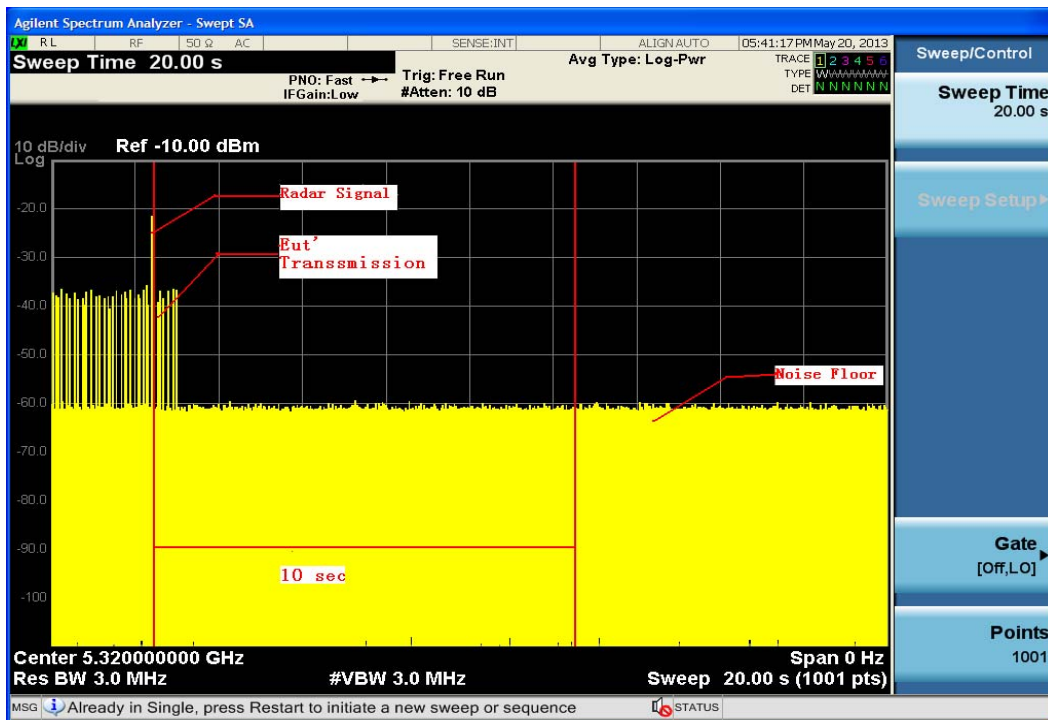

**Note:** An expanded plot for the device vacates the channel in the required 500ms



TX (A Mode )

Radar signal 4

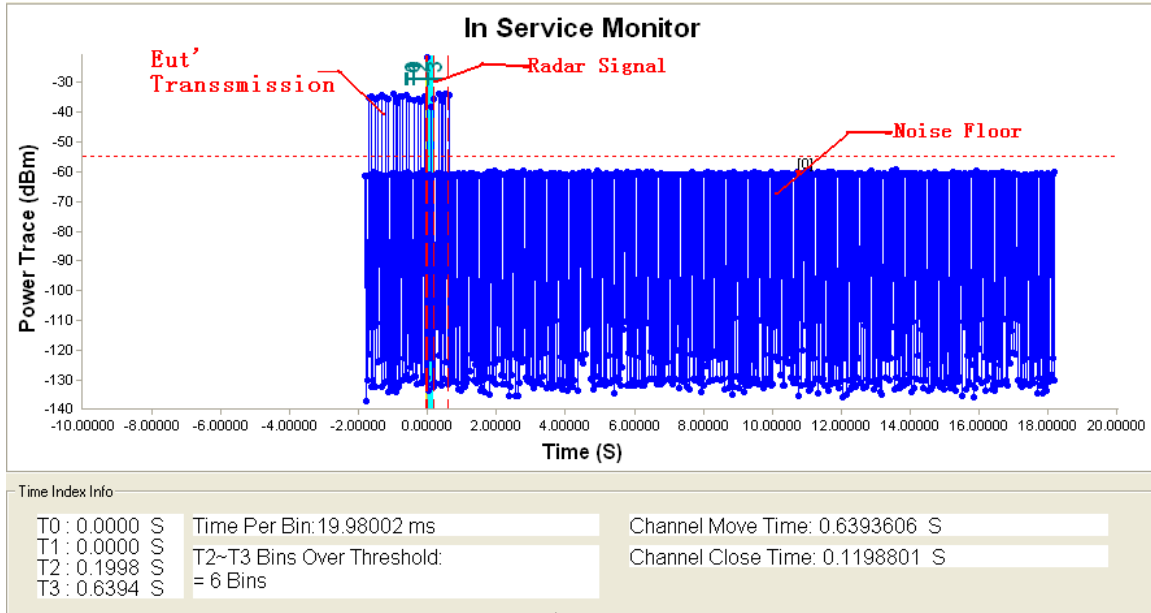

**Note:** T1 denotes the start of Channel Move Time upon the end of the last Radar burst.  
 T2 denotes the data transmission time of 200ms from T1.  
 T3 denotes the end of Channel Move Time.  
 T4 denotes the 10 second from T1 to observe the aggregate duration of transmissions.

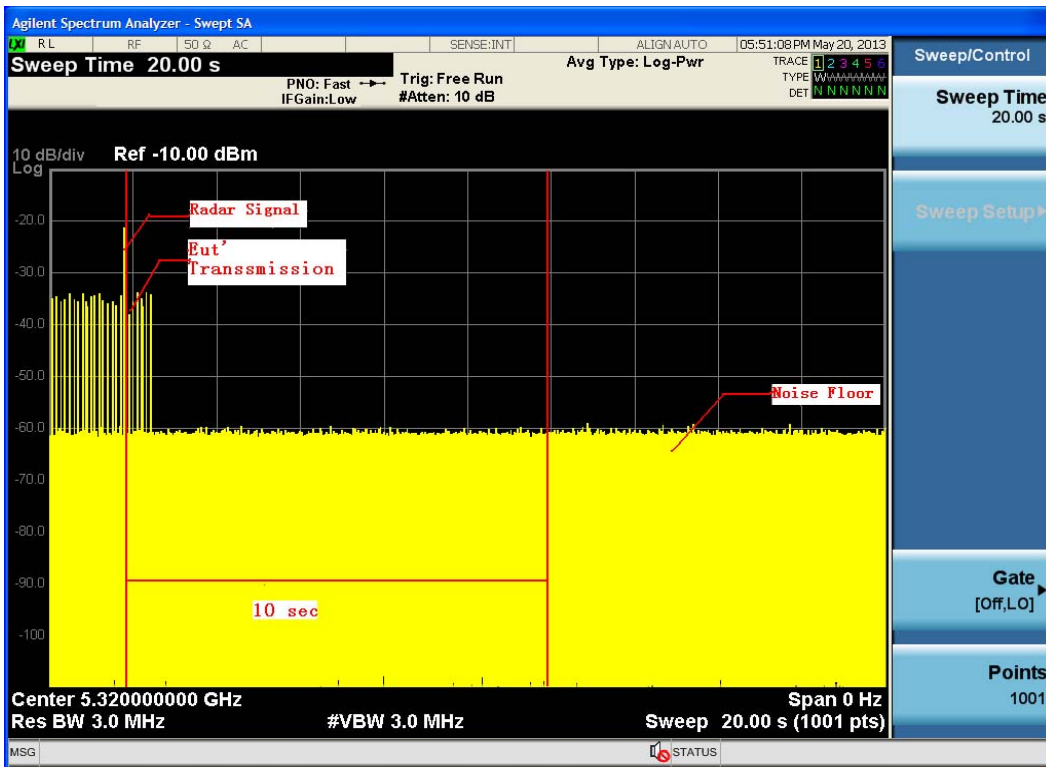

**Note:** An expanded plot for the device vacates the channel in the required 500ms



TX (A Mode )

Radar signal 5

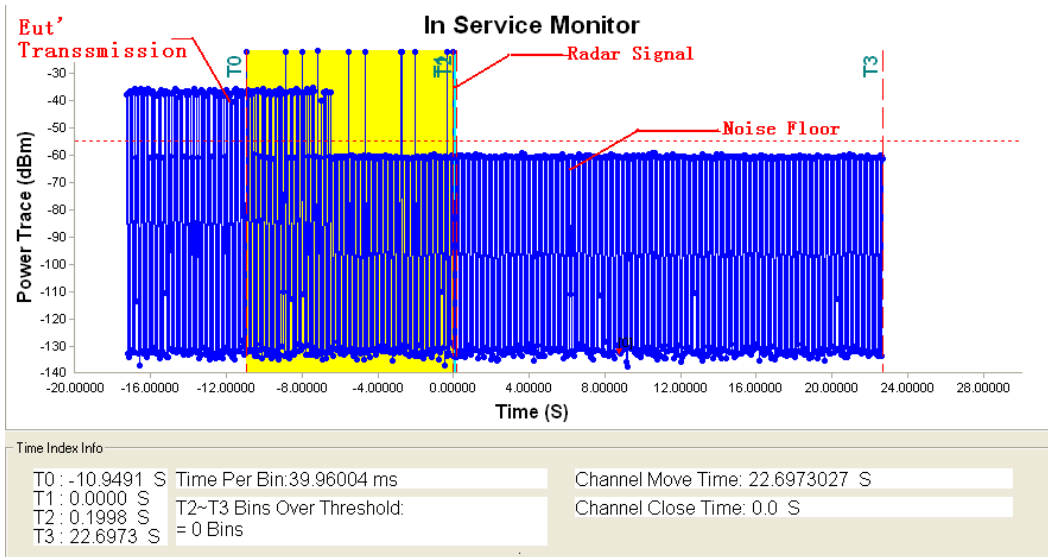

**Note:** T1 denotes the start of Channel Move Time upon the end of the last Radar burst.  
 T2 denotes the data transmission time of 200ms from T1.  
 T3 denotes the end of Channel Move Time.  
 T4 denotes the 10 second from T1 to observe the aggregate duration of transmissions.

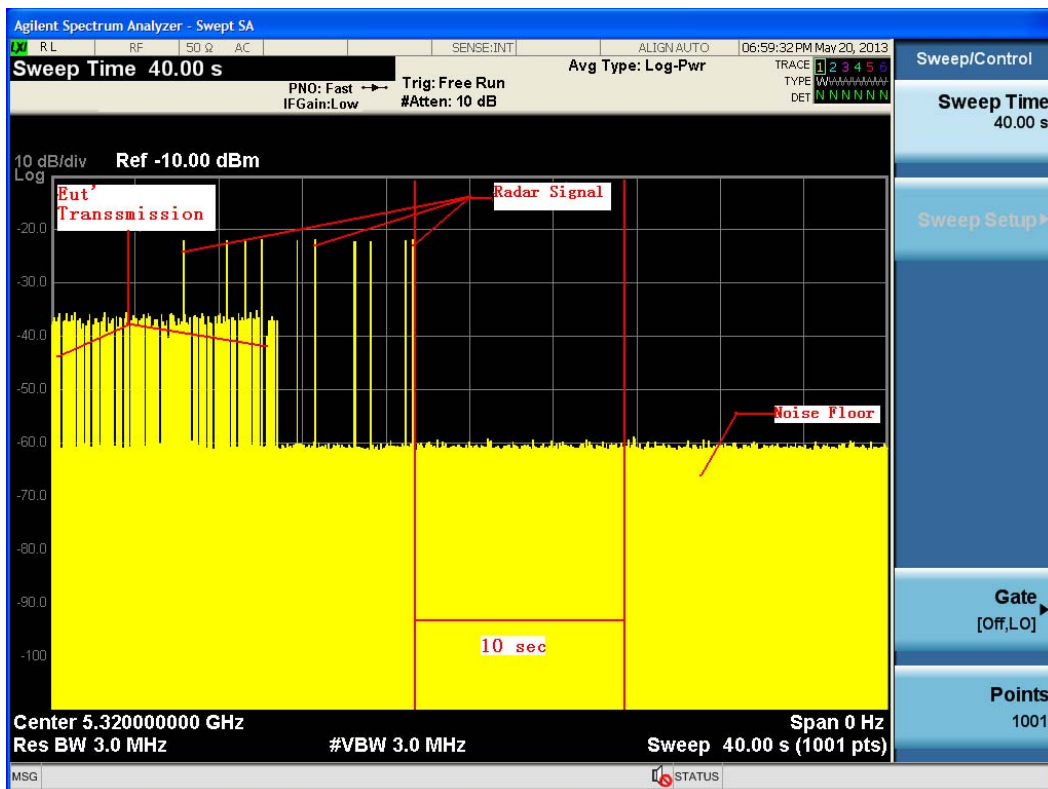

**Note:** An expanded plot for the device vacates the channel in the required 500ms





TX (A Mode )

Radar signal 6

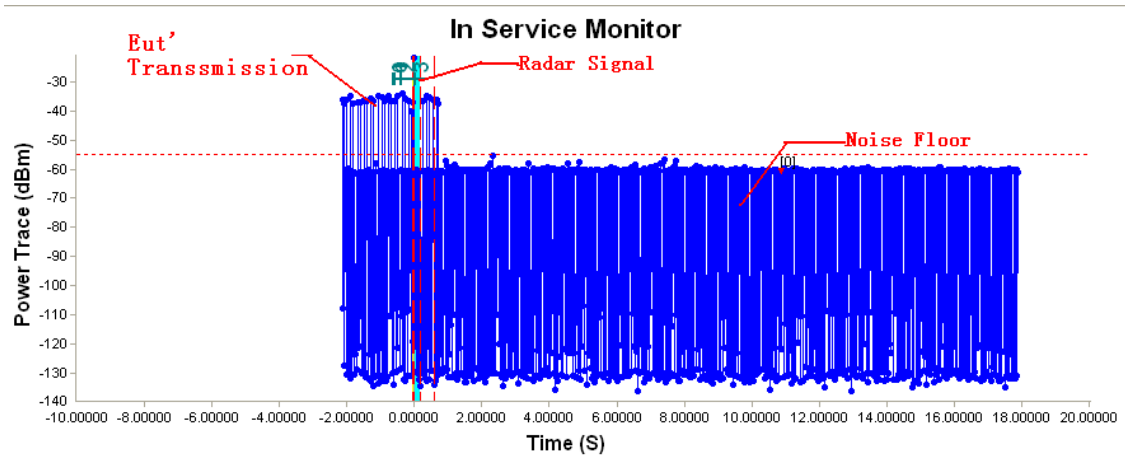

Time Index Info		
T0: 0.0000 S	Time Per Bin: 19.98002 ms	Channel Move Time: 0.7192807 S
T1: 0.0000 S	T2~T3 Bins Over Threshold: = 6 Bins	Channel Close Time: 0.1198801 S
T2: 0.1998 S		
T3: 0.7193 S		

**Note:** T1 denotes the start of Channel Move Time upon the end of the last Radar burst.  
 T2 denotes the data transmission time of 200ms from T1.  
 T3 denotes the end of Channel Move Time.  
 T4 denotes the 10 second from T1 to observe the aggregate duration of transmissions.

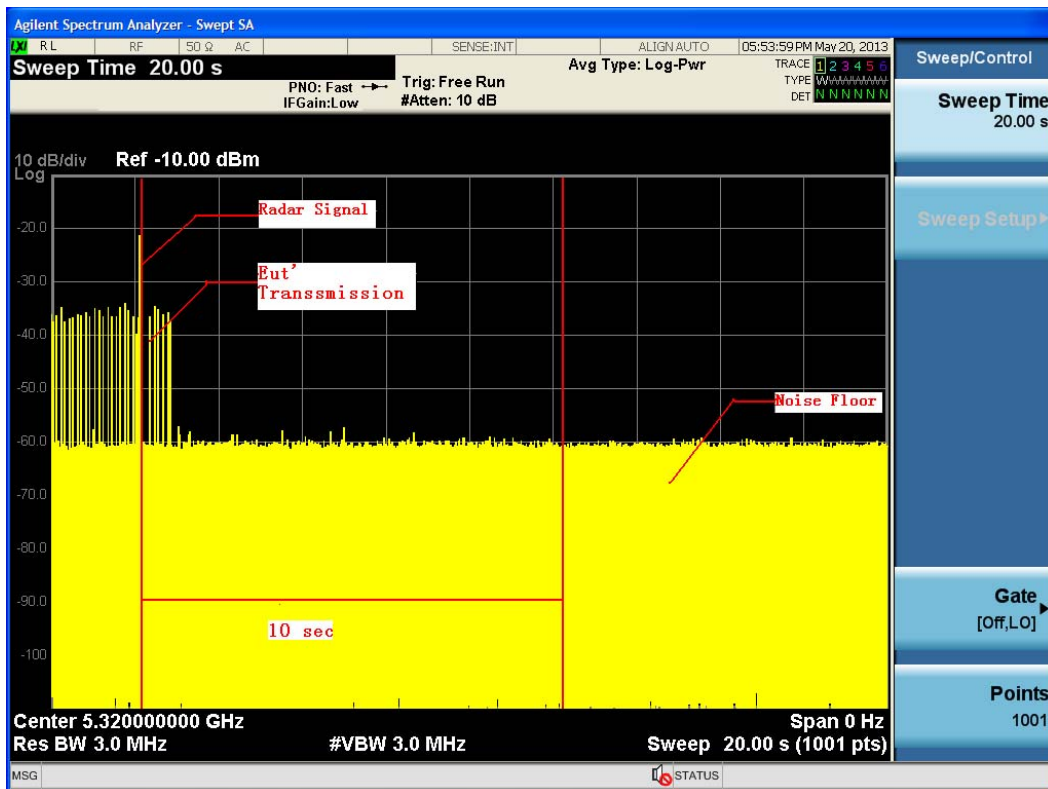

**Note:** An expanded plot for the device vacates the channel in the required 500ms



TX (N40 Mode )

Radar signal 1

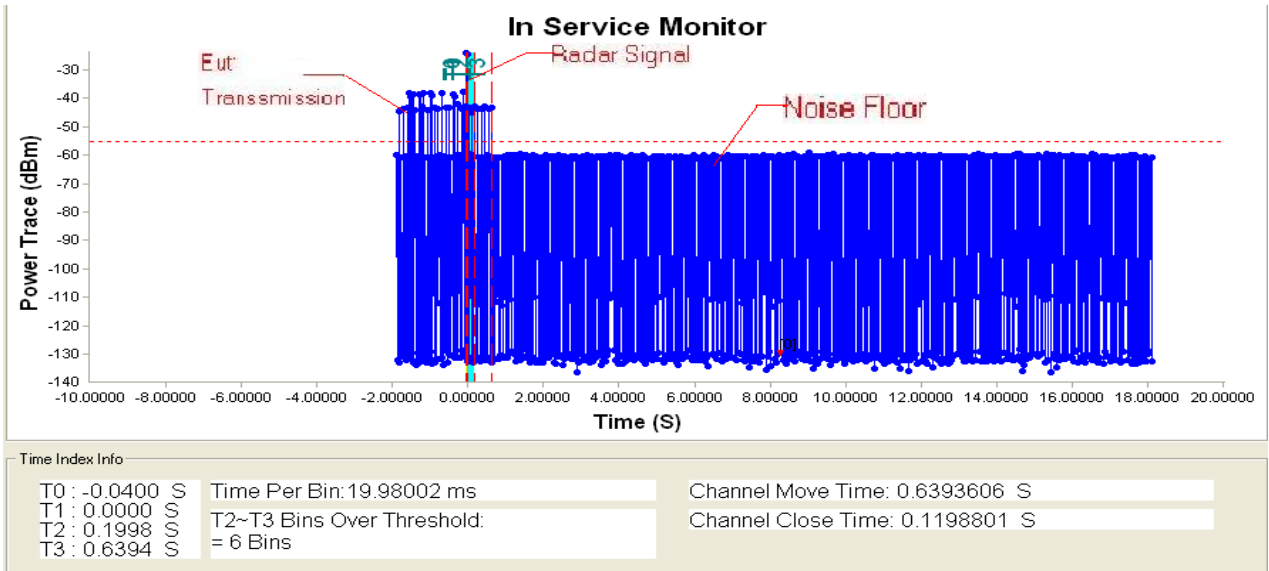

**Note:** T1 denotes the start of Channel Move Time upon the end of the last Radar burst.  
 T2 denotes the data transmission time of 200ms from T1.  
 T3 denotes the end of Channel Move Time.  
 T4 denotes the 10 second from T1 to observe the aggregate duration of transmissions.

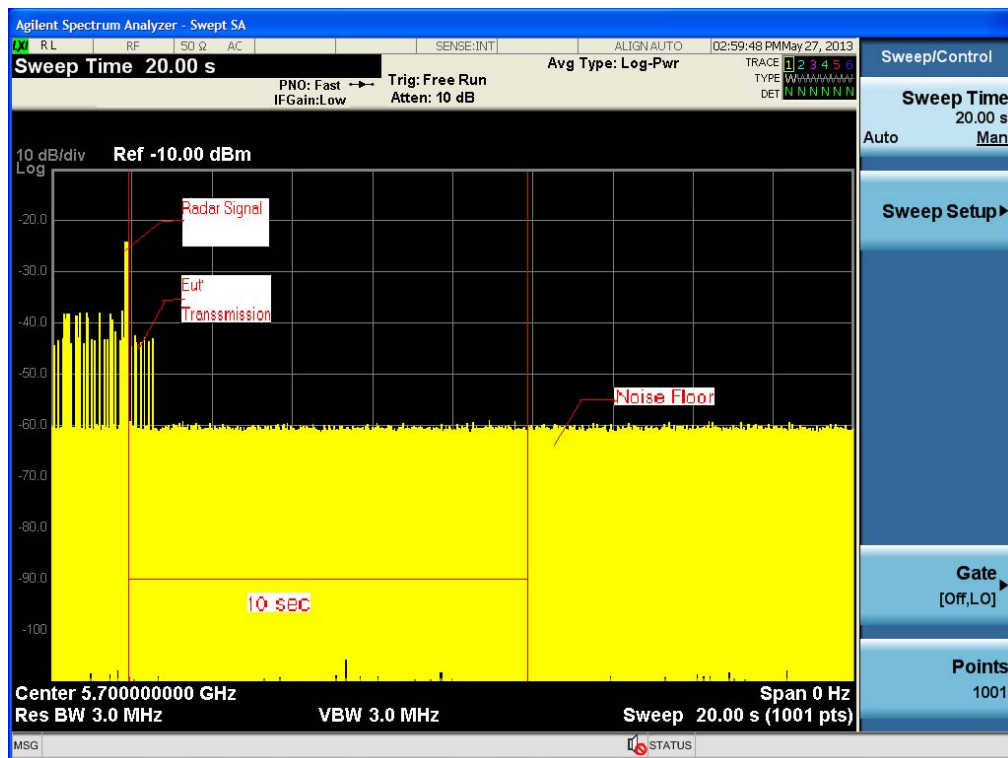

**Note:** An expanded plot for the device vacates the channel in the required 500ms



TX (N40 Mode )

Radar signal 2

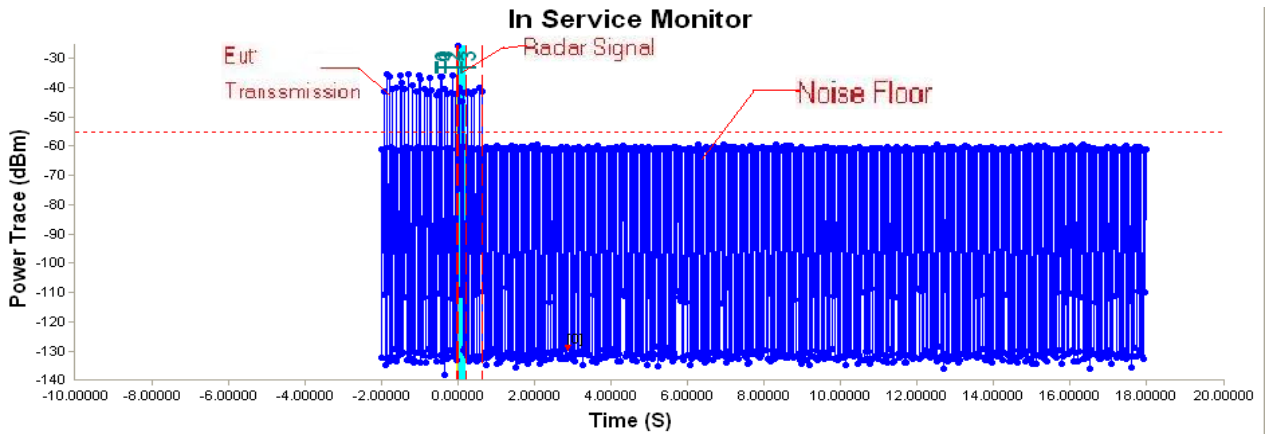

Time Index Info		
T0 : 0.0000 S	Time Per Bin: 19.98002 ms	Channel Move Time: 0.6393606 S
T1 : 0.0000 S	T2~T3 Bins Over Threshold: = 5 Bins	Channel Close Time: 0.0999001 S
T2 : 0.1998 S		
T3 : 0.6394 S		

**Note:** T1 denotes the start of Channel Move Time upon the end of the last Radar burst.  
 T2 denotes the data transmission time of 200ms from T1.  
 T3 denotes the end of Channel Move Time.  
 T4 denotes the 10 second from T1 to observe the aggregate duration of transmissions.

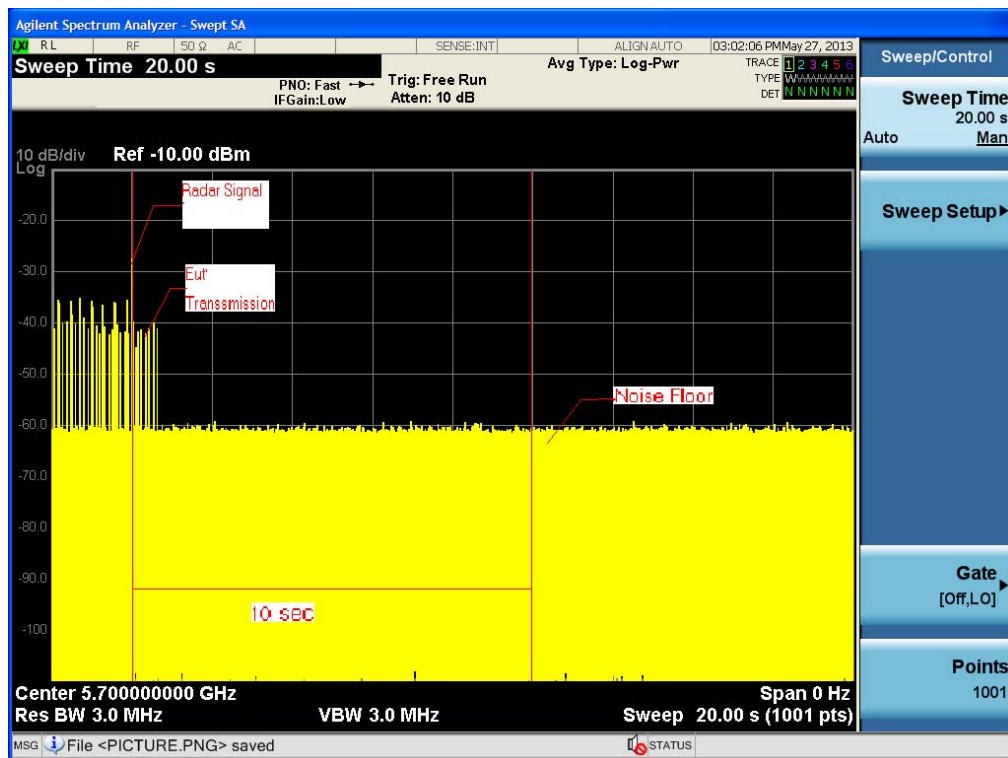

**Note:** An expanded plot for the device vacates the channel in the required 500ms



TX (N40 Mode )

Radar signal 3

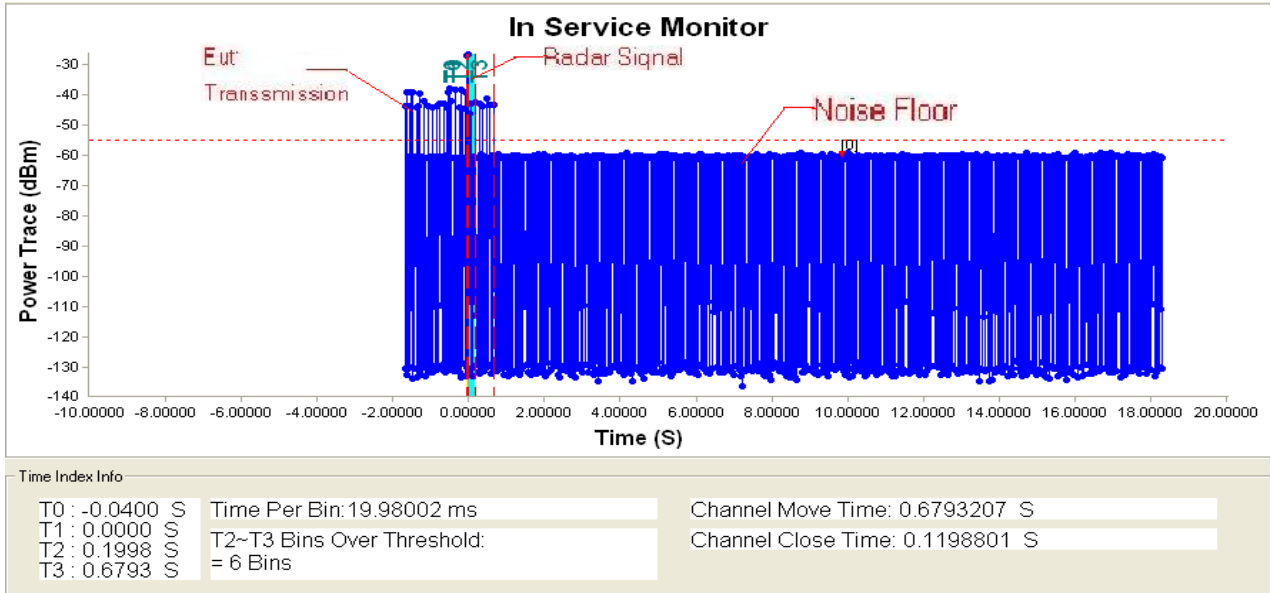

**Note:** T1 denotes the start of Channel Move Time upon the end of the last Radar burst.  
 T2 denotes the data transmission time of 200ms from T1.  
 T3 denotes the end of Channel Move Time.  
 T4 denotes the 10 second from T1 to observe the aggregate duration of transmissions.

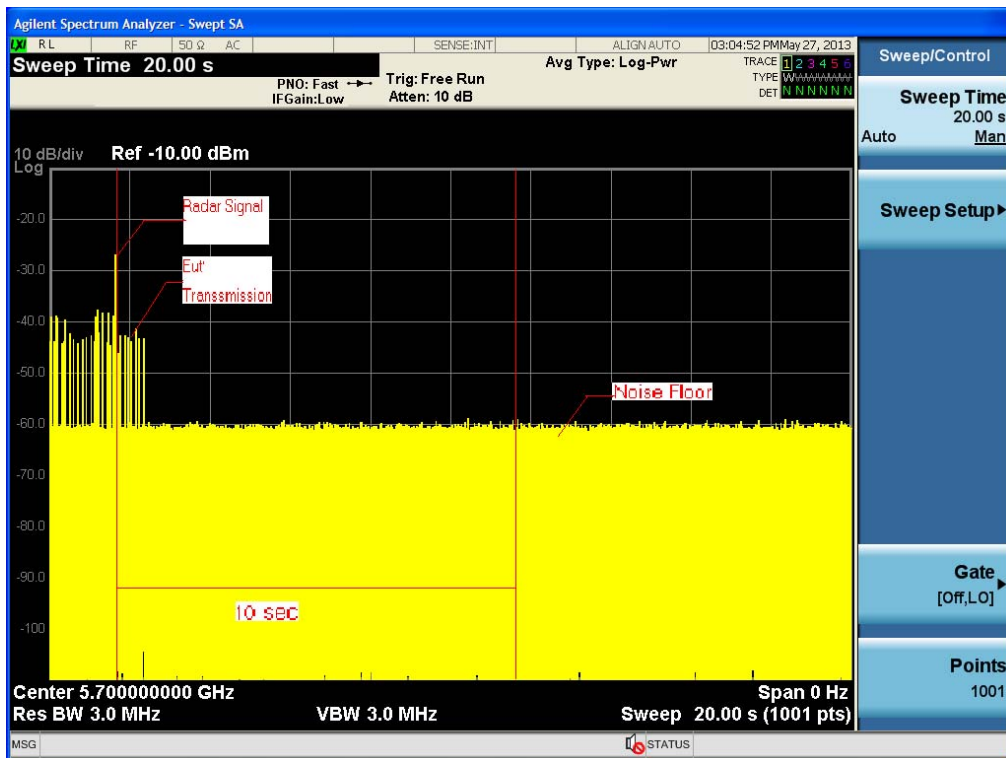

**Note:** An expanded plot for the device vacates the channel in the required 500ms



TX (N40 Mode )

Radar signal 4

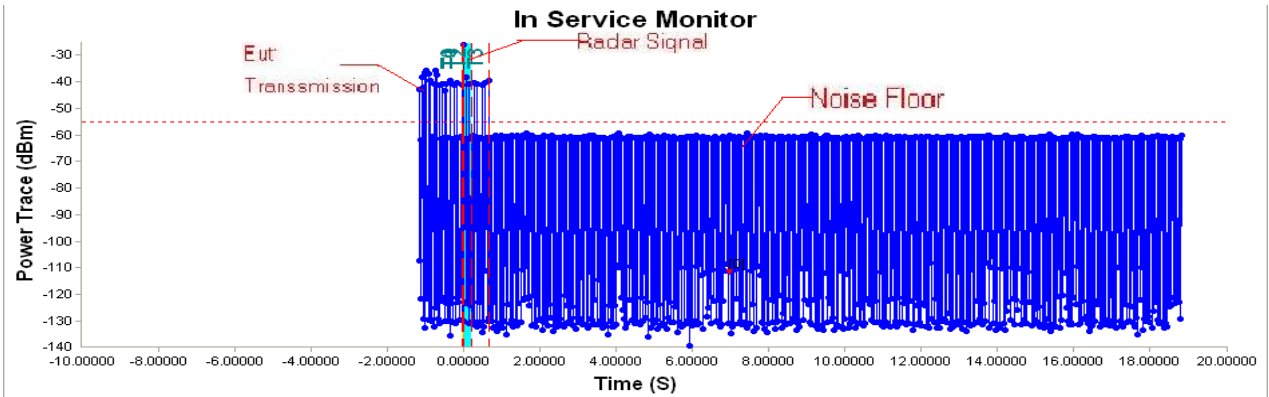

Time Index Info			
T0 : 0.0000 S	Time Per Bin: 19.98002 ms	Channel Move Time: 0.6793207 S	
T1 : 0.0000 S	T2~T3 Bins Over Threshold: = 5 Bins	Channel Close Time: 0.0999001 S	
T2 : 0.1998 S			
T3 : 0.6793 S			

**Note:** T1 denotes the start of Channel Move Time upon the end of the last Radar burst.  
 T2 denotes the data transmission time of 200ms from T1.  
 T3 denotes the end of Channel Move Time.  
 T4 denotes the 10 second from T1 to observe the aggregate duration of transmissions.

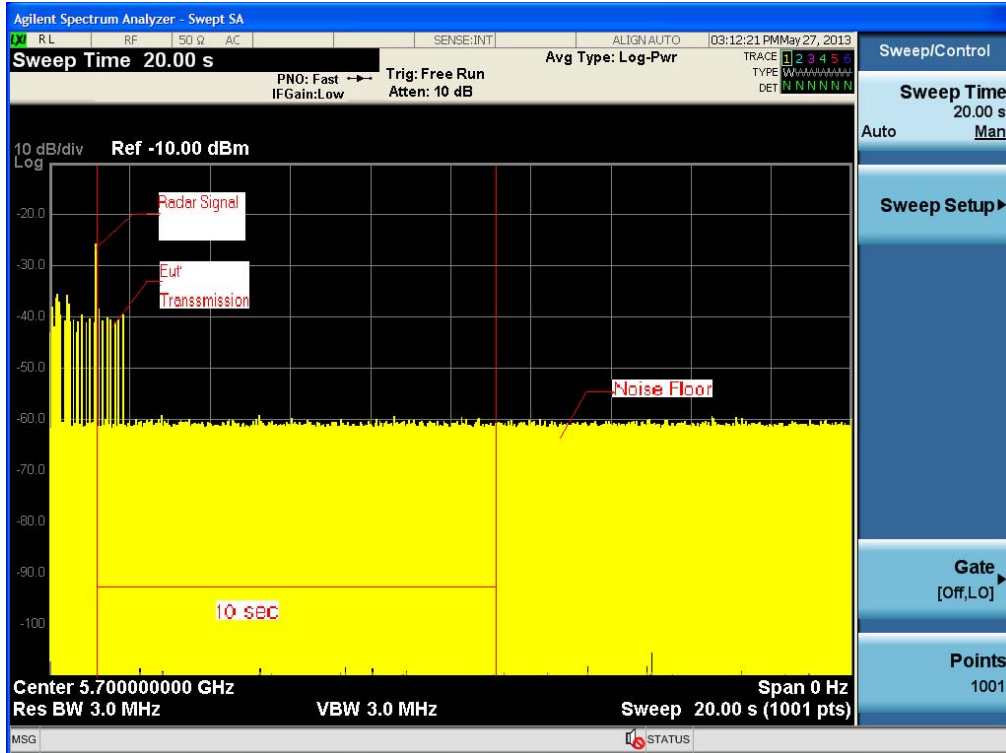

**Note:** An expanded plot for the device vacates the channel in the required 500ms



TX (N40 Mode )

Radar signal 5

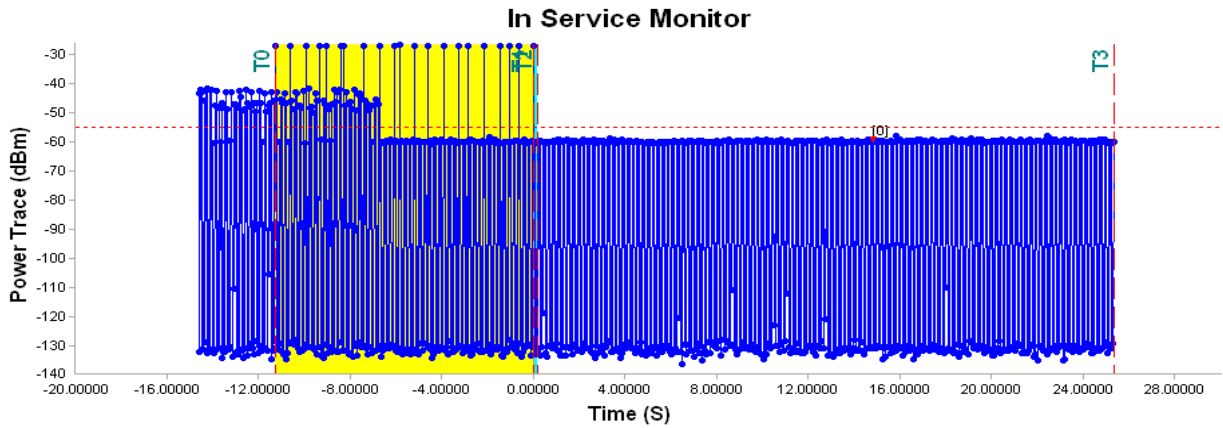

Time Index Info			
T0 : -11.2687 S	Time Per Bin: 39.96004 ms	Channel Move Time: 25.3346653 S	
T1 : 0.0000 S	T2~T3 Bins Over Threshold: = 0 Bins	Channel Close Time: 0.0 S	
T2 : 0.1998 S			
T3 : 25.3347 S			

**Note:** T1 denotes the start of Channel Move Time upon the end of the last Radar burst.  
 T2 denotes the data transmission time of 200ms from T1.  
 T3 denotes the end of Channel Move Time.  
 T4 denotes the 10 second from T1 to observe the aggregate duration of transmissions.

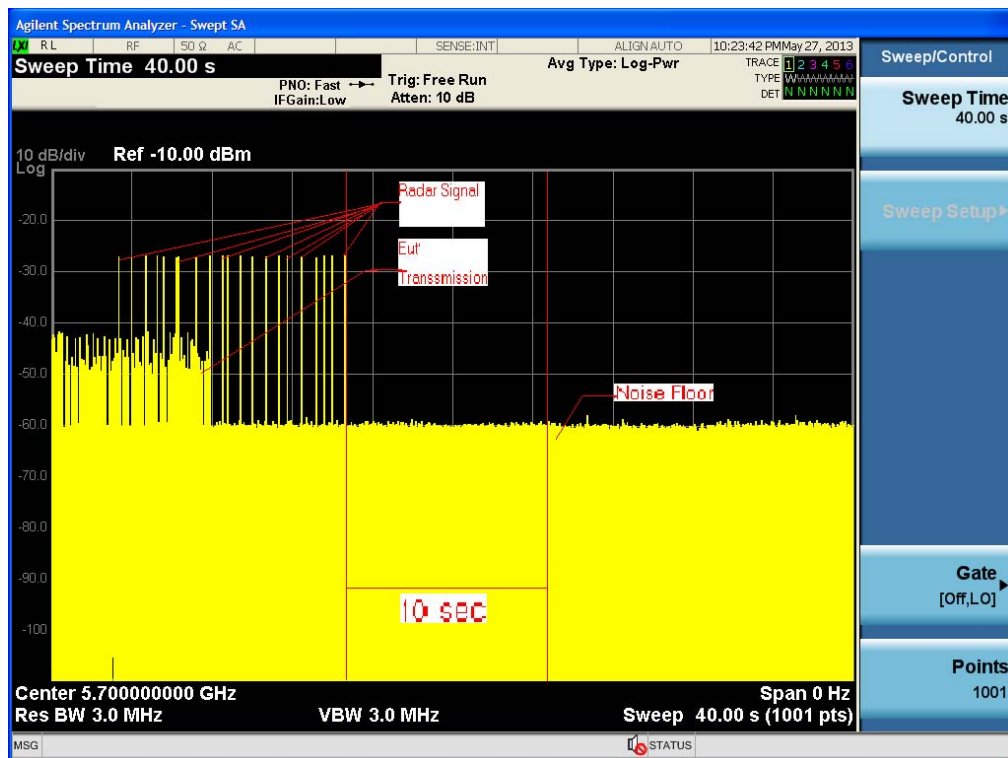

**Note:** An expanded plot for the device vacates the channel in the required 500ms



TX (N40 Mode )

Radar signal 6

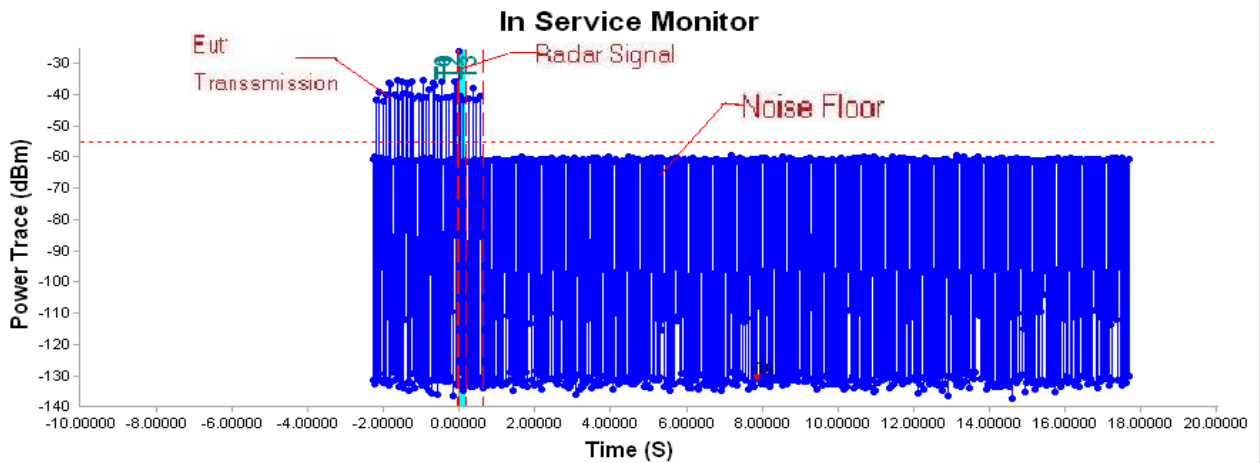

Time Index Info

T0 : 0.0000 S	Time Per Bin: 19.98002 ms	Channel Move Time: 0.5594406 S
T1 : 0.0000 S	T2-T3 Bins Over Threshold: = 4 Bins	Channel Close Time: 0.0799201 S
T2 : 0.1998 S		
T3 : 0.5594 S		

**Note:** T1 denotes the start of Channel Move Time upon the end of the last Radar burst.  
 T2 denotes the data transmission time of 200ms from T1.  
 T3 denotes the end of Channel Move Time.  
 T4 denotes the 10 second from T1 to observe the aggregate duration of transmissions.

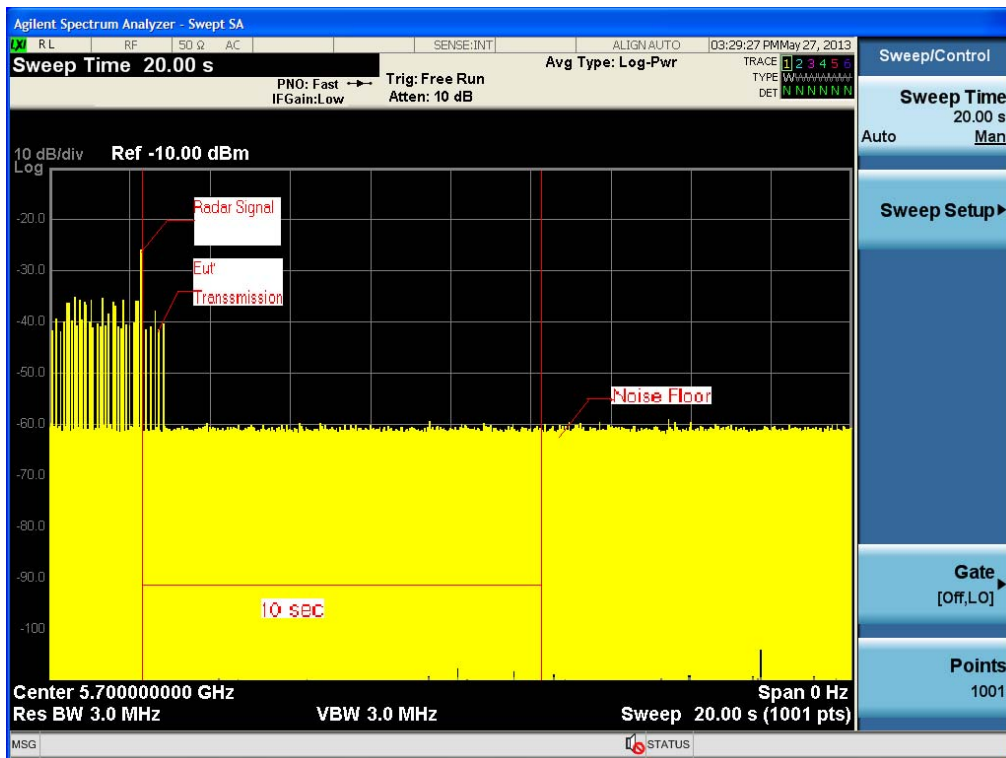

**Note:** An expanded plot for the device vacates the channel in the required 500ms



**7. TEST SETUP PHOTOS**

