



**FCC 47 CFR PART 15 SUBPART C AND ANSI C63.4:2009
TEST REPORT (Class II Permissive Change Report)**

For

DreamTab HD8

Model : DMTAB-IN08A

Trade Name : nabi

Issued for

Foxconn International Inc.

No.2,Ziyou St.,Tucheng Dist., New Taipei City 236,Taiwan

Issued by

**Compliance Certification Services Inc.
Hsinchu Lab.**

**NO. 989-1 Wen Shan Rd., Shang Shan Village,
Qionglin Shiang Hsinchu County 30741, Taiwan, R.O.C**

TEL: +886-3-5921698

FAX: +886-3-5921108

<http://www.ccsrf.com>

E-Mail : service@ccsrf.com

Issued Date: April 17, 2014



Note: This report shall not be reproduced except in full, without the written approval of Compliance Certification Services Inc. This document may be altered or revised by Compliance Certification Services Inc. personnel only, and shall be noted in the revision section of the document. The client should not use it to claim product endorsement by TAF or any government agencies. The test results of this report relate only to the tested sample identified in this report.



Revision History

Rev.	Issue Date	Revisions	Effect Page	Revised By
00	03/31/2014	Initial Issue	All Page 31	Gloria Chang
01	04/17/2014	Adding Battery Source (Class II Change)	All Page 22	Gloria Chang



TABLE OF CONTENTS

TITLE	PAGE NO.
1. TEST REPORT CERTIFICATION	4
2. EUT DESCRIPTION	5
2.1 DESCRIPTION OF EUT & POWER.....	5
2.2 DESCRIPTION OF CLASS II CHANGE	5
3. DESCRIPTION OF TEST MODES	6
4. TEST METHODOLOGY	7
5. FACILITIES AND ACCREDITATION	7
5.1 FACILITIES	7
5.2 ACCREDITATIONS.....	7
5.3 MEASUREMENT UNCERTAINTY	8
6. SETUP OF EQUIPMENT UNDER TEST.....	9
7. FCC PART 15.225 REQUIREMENTS	10
7.1 RADIATED EMISSION.....	10-15
7.2 CONDUCTED EMISSION	16-20
APPENDIX SETUP PHOTOS	21-22



1. TEST REPORT CERTIFICATION

Applicant : Foxconn International Inc.
Address : No.2,Ziyou St.,Tucheng Dist., New Taipei City 236,Taiwan
Equipment Under Test : DreamTab HD8
Model : DMTAB-IN08A
Trade Name : nabi
Tested Date : March 12 ~ 28, 2014 ; April 14, 2014

APPLICABLE STANDARD	
Standard	Test Result
FCC Part 15 Subpart C AND ANSI C63.4:2009	PASS

WE HEREBY CERTIFY THAT: The above equipment has been tested by Compliance Certification Services Inc., and found compliance with the requirements set forth in the technical standards mentioned above. The results of testing in this report apply only to the product/system, which was tested. Other similar equipment will not necessarily produce the same results due to production tolerance and measurement uncertainties.

Approved by:

Rex Liao
Deputy Manager

Reviewed by:

Jacky Chen
Section Manager



2. EUT DESCRIPTION

2.1 DESCRIPTION OF EUT & POWER

Product Name	DreamTab HD8
Model Number	DMTAB-IN08A
Identify Number	T140414D01
Received Date	March 12, 2014
Frequency Range	13.56MHz
Transmit Power	56.70 dBµV/m @ 3m
Type of Modulation	ASK
Power Rating	3.7Vdc, 4500mAh, 16.65Wh (For Battery) 5Vdc (For Charging)
Test Voltage	120Vac, 60Hz
I/O Port	USB Port x 1, Micro SD Port x 1, Audio Port x 1
Signal Cable	Shielded USB Cable 1m x 1

Power Adapter :

No.	Manufacturer	Model No.	Power Input	Power Output
1	Chicony	W12-010N3A	100-240Vac, 50/60Hz, 0.3A	5Vdc, 2A

Remark :

1. The sample selected for test was engineering sample that approximated to production product and was provided by manufacturer.
2. For more details, please refer to the User's manual of the EUT.
3. This submittal(s) (test report) is intended for FCC ID:SIB-DMTAB-IN08A filing to comply with Section 15.207, 15.209 and 15.225 of the FCC Part 15, Subpart C Rules.
4. This report is modified from T140312D11-RP1-3.

2.2 DESCRIPTION OF CLASS II CHANGE

The major change filed under this application is :

The subject DMTAB-IN08A approved battery origin model will be McNair / MLP4566111. This time we add a new battery model Name: SPRINGPOWER TECHNOLOG / SP5067112 for second source ; The rating will be the same as the origin one following 3.7V 4500mAh 16.65Wh.

After pre-scan, the testing was performed and chosen the radiation below 1GHz data and conduction data, please refer to section 7.1 and 7.2.

Other testing items data was showed as original application document reports (report number: T140312D11-RP1-3).



3. DESCRIPTION OF TEST MODES

The EUT (DreamTab HD8) had been tested under operating condition.

Conducted Emission / Radiated Emission Test (Above 30 MHz) :

1. The following test modes were scanned during the preliminary test:

No.	Pre-Test Mode
1	Charge Mode + Play Video
2	Charge Mode + REC (with Front Camera)
3	Charge Mode + REC (with Back Camera)
4	Normal Operating + Link Notebook PC Read
5	Normal Operating + Link Notebook PC Write

2. After the preliminary scan, the following test mode was found to produce the highest emission level.

Final Test Mode		
Emission	Radiated Emission	Normal Operating + Link Notebook PC Write
	Conducted Emission	Charge Mode + Play Video

Remark : Then, the above highest emission mode of the configuration of the EUT and cable was chosen for all final test items.



4. TEST METHODOLOGY

The tests documented in this report were performed in accordance with ANSI C63.4:2009 and FCC CFR 47, 15.207, 15.209 and 15.225.

5. FACILITIES AND ACCREDITATION

5.1 FACILITIES

All measurement facilities used to collect the measurement data are located at

NO. 989-1 Wen Shan Rd., Shang Shan Village,
Qionglin Shiang Hsinchu County 30741, Taiwan, R.O.C

The sites are constructed in conformance with the requirements of ANSI C63.4:2009 and CISPR 22. All receiving equipment conforms to CISPR 16-1-1, CISPR 16-1-2, CISPR 16-1-3, CISPR 16-1-4, CISPR 16-1-5.

5.2 ACCREDITATIONS

Our laboratories are accredited and approved by the following approval agencies according to ISO/IEC 17025.

Taiwan	TAF
---------------	-----

The measuring facility of laboratories has been authorized or registered by the following approval agencies.

Canada	INDUSTRY CANADA
Japan	VCCI
Taiwan	BSMI
USA	FCC MRA

Copies of granted accreditation certificates are available for downloading from our web site, <http://www.ccsrf.com>



5.3 MEASUREMENT UNCERTAINTY

The following table is for the measurement uncertainty, which is calculated as per the document CISPR 16-4-2.

PARAMETER	UNCERTAINTY
Semi Anechoic Chamber (966 Chamber_A) / Radiated Emission, 0.009 to 30 MHz	+/- 1.52
Semi Anechoic Chamber (966 Chamber_A) / Radiated Emission, 30 to 1000 MHz	+/- 3.59
Semi Anechoic Chamber (966 Chamber_A) / Radiated Emission, 1 to 18GHz	+/- 3.59
Semi Anechoic Chamber (966 Chamber_A) / Radiated Emission, 18 to 26 GHz	+/- 3.59
Semi Anechoic Chamber (966 Chamber_A) / Radiated Emission, 26 to 40 GHz	+/- 3.82
Semi Anechoic Chamber (966 Chamber_B) / Radiated Emission, 30 to 1000 MHz	+/- 3.97
Semi Anechoic Chamber (966 Chamber_B) / Radiated Emission, 1 to 18GHz	+/- 3.58
Semi Anechoic Chamber (966 Chamber_B) / Radiated Emission, 18 to 26 GHz	+/- 3.59
Semi Anechoic Chamber (966 Chamber_B) / Radiated Emission, 26 to 40 GHz	+/- 3.81
Conducted Emission (Mains Terminals), 9kHz to 30MHz	+/- 2.48

This uncertainty represents an expanded uncertainty expressed at approximately the 95% confidence level using a coverage factor of $k=2$.

Consistent with industry standard (e.g. CISPR 22, clause 11, Measurement Uncertainty) determining compliance with the limits shall be based on the results of the compliance measurement. Consequently the measured emissions being less than the maximum allowed emission result in this being a compliant test or passing test.

The acceptable measurement uncertainty value without requiring revision of the compliance statement is based on conducted and radiated emissions being less than U_{CISPR} which is 3.6dB and 5.2dB respectively. CCS values (called U_{Lab} in CISPR 16-4-2) is less than U_{CISPR} as shown in the table above. Therefore, MU need not be considered for compliance.



6. SETUP OF EQUIPMENT UNDER TEST

SUPPORT EQUIPMENT

No.	Product	Manufacturer	Model No.	Serial No.	FCC ID
1	Notebook PC	TOSHIBA	M840	9C104267C	DoC
2	LCD Monitor	DELL	2407WFPb	CN-0FC255-4663 3-6CP-06JS	DoC
3	Keyboard	HP	KU-0316	35563-AB1	DoC
4	Mouse	HP	M-UAE96	265986-011	DoC
5	Headset	Acon	CW-010.V	---	---

SETUP DIAGRAM FOR TESTS

EUT & peripherals setup diagram is shown in appendix setup photos.

EUT OPERATING CONDITION

1. EUT & peripherals setup diagram is shown in appendix setup photos.
2. a. Notebook PC software to write with EUT.
b. Charge Mode and play video.
3. All of the functions are under run.
4. Start test.



7. FCC PART 15.225 REQUIREMENTS

7.1 RADIATED EMISSION

LIMITS

(1) According to § 15.205 (a) Except as shown in paragraph (d) of this section, only spurious emissions are permitted in any of the frequency bands listed below:

MHz	MHz	MHz	GHz
0.090 - 0.110	16.42 - 16.423	399.9 - 410	4.5 - 5.15
¹ 0.495 - 0.505	16.69475 - 16.69525	608 - 614	5.35 - 5.46
2.1735 - 2.1905	16.80425 - 16.80475	960 - 1240	7.25 - 7.75
4.125 - 4.128	25.5 - 25.67	1300 - 1427	8.025 - 8.5
4.17725 - 4.17775	37.5 - 38.25	1435 - 1626.5	9.0 - 9.2
4.20725 - 4.20775	73 - 74.6	1645.5 - 1646.5	9.3 - 9.5
6.215 - 6.218	74.8 - 75.2	1660 - 1710	10.6 - 12.7
6.26775 - 6.26825	108 - 121.94	1718.8 - 1722.2	13.25 - 13.4
6.31175 - 6.31225	123 - 138	2200 - 2300	14.47 - 14.5
8.291 - 8.294	149.9 - 150.05	2310 - 2390	15.35 - 16.2
8.362 - 8.366	156.52475 - 156.52525	2483.5 - 2500	17.7 - 21.4
8.37625 - 8.38675	156.7 - 156.9	2655 - 2900	22.01 - 23.12
8.41425 - 8.41475	162.0125 - 167.17	3260 - 3267	23.6 - 24.0
12.29 - 12.293	167.72 - 173.2	3332 - 3339	31.2 - 31.8
12.51975 - 12.52025	240 - 285	3345.8 - 3338	36.43 - 36.5
12.57675 - 12.57725	322 - 335.4	3600 - 4400	(²)
13.36 - 13.41			

Remark:

1. ¹ Until February 1, 1999, this restricted band shall be 0.490-0.510 MHz.
2. ² Above 38.6

(2) According to § 15.205 (b) Except as provided in paragraphs (d) and (e), the field strength of emissions appearing within these frequency bands shall not exceed the limits shown in Section 15.209. At frequencies equal to or less than 1000 MHz, compliance with the limits in Section 15.209 shall be demonstrated using measurement instrumentation employing a CISPR quasi-peak detector. Above 1000 MHz, compliance with the emission limits in Section 15.209 shall be demonstrated based on the average value of the measured emissions. The provisions in Section 15.35 apply to these measurements.



(3) According to §15.225,

- (a) The field strength of any emissions within the band 13.553 – 13.567 MHz shall not exceed 15,848 microvolts / meter at 30 meters.
- (b) Within the bands 13.410 – 13.553 MHz and 13.567 -13.710 MHz, the field strength of any emissions shall not exceed 334 microvolts / meter at 30 meters.
- (c) Within the bands 13.110 – 13.410 MHz and 13.710 – 14.010 MHz the field strength of any emissions shall not exceed 106 microvolts / meter at 30 meters.
- (d) The field strength of any emissions appearing outside of the 13.110 – 14.010 MHz and shall not exceed the general radiated emission limits in §15.209.

(4) According to § 15.209 (a) Except as provided elsewhere in this Subpart, the emissions from an intentional radiator shall not exceed the field strength levels specified in the following table :

Frequency (MHz)	Field Strength (microvolts/meter)	Measurement Distance (meters)
0.009 – 0.490	2400/F(KHz)	300
0.490 – 1.705	24000/F(KHz)	30
1.705 – 30.0	30	30
30 - 88	100 **	3
88 - 216	150 **	3
216 - 960	200 **	3
Above 960	500	3

Remark: **Except as provided in paragraph (g), fundamental emissions from intentional radiators operating under this Section shall not be located in the frequency bands 54-72 MHz, 76-88 MHz, 174-216 MHz or 470-806 MHz. However, operation within these frequency bands is permitted under other sections of this Part, e.g., Sections 15.231 and 15.241.

(5) According to § 15.209 (b) In the emission table above, the tighter limit applies at the band edges.

**TEST EQUIPMENT****Radiated Emission / 966Chamber_A**

Name of Equipment	Manufacturer	Model	Serial Number	Calibration Due
Spectrum Analyzer	Agilent	E4446A	MY43360132	06/10/2014
EMI Receiver	ROHDE & SCHWARZ	ESCI	100221	04/29/2014
Bi-log Antenna	SCHWARZBECK	VULB 9168	9168-249	09/12/2014
Broad-Band Horn Antenna	SCHWARZBECK	BBHA 9120 D	9120D-778	09/12/2014
Pre-Amplifier	Agilent	8449B	3008A01471	07/16/2014
Pre-Amplifier	HP	8447F	2944A03748	07/16/2014
LOOP Antenna	EMCO	6502	8905-2356	08/20/2014
Band Reject Notch Filter	Micro-Tronics	BRM05702-01	009	N.C.R

Remark: 1. Each piece of equipment is scheduled for calibration once a year.
2. N.C.R = No Calibration Request.

Radiated Emission / 966Chamber_B

Name of Equipment	Manufacturer	Model	Serial Number	Calibration Due
Spectrum Analyzer	Agilent	E4446A	MY46180323	04/15/2015
EMI Test Receiver	ROHDE & SCHWARZ	ESCI	101387	10/09/2014
Bi-log Antenna	SCHWARZBECK	VULB 9168	9168-250	09/12/2014
Broad-Band Horn Antenna	SCHWARZBECK	BBHA 9120 D	9120D-778	09/12/2014
Double-Ridged Waveguide Horn	ETS-LINDGREN	3117	00078733	12/05/2014
Horn Antenna	COM-POWER	AH-840	03077	12/18/2014
Pre-Amplifier	Agilent	8447D	2944A10052	07/16/2014
Pre-Amplifier	Agilent	8449B	3008A01916	07/16/2014
Notch Filters Band Reject	Micro-Tronics	BRM05702-01	026	N.C.R

Remark: 1. Each piece of equipment is scheduled for calibration once a year.
2. N.C.R = No Calibration Request.



TEST SETUP

The diagram below shows the test setup that is utilized to make the measurements for emission below 1GHz.

9kHz ~ 30MHz

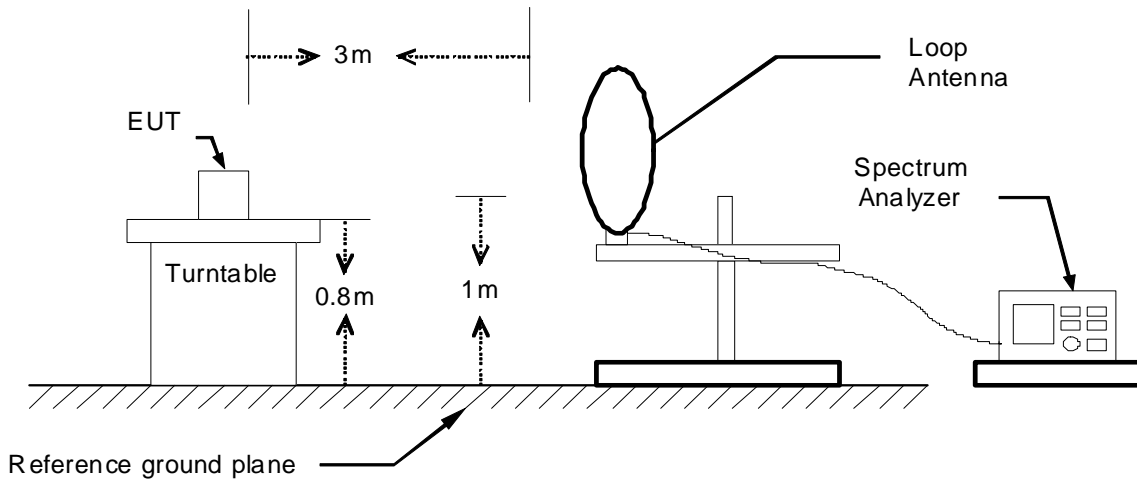

30MHz ~ 1GHz

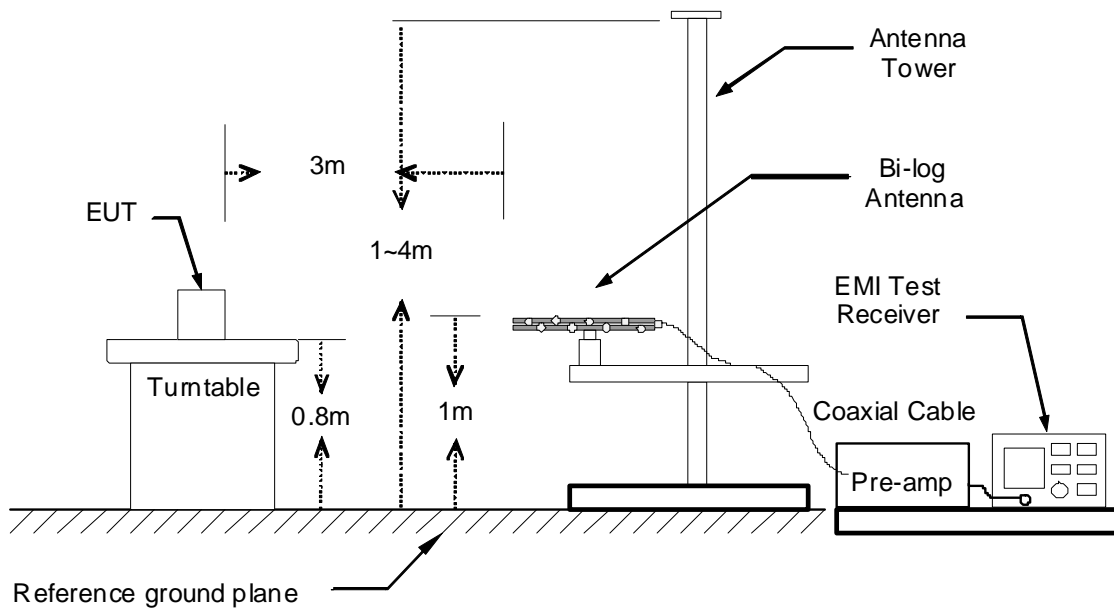



TEST PROCEDURE

1. The EUT was placed on the top of a rotating table 0.8 meters above the ground. The table was rotated 360 degrees to determine the position of the highest radiation.
2. While measuring the radiated emission below 1GHz, the EUT was set 3 meters away from the interference-receiving antenna, which was mounted on the top of a variable-height antenna tower. While measuring the radiated emission above 1GHz, the EUT was set 3 meters away from the interference-receiving antenna.
3. The antenna is a broadband antenna, and its height is varied from one meter to four meters above the ground to determine the maximum value of the field strength. Both horizontal and vertical polarization of the antenna are set to make the measurement.
4. For each suspected emission, the EUT was arranged to its worst case and then the antenna was tuned to heights from 1 meter to 4 meters and the table was turned from 0 degrees to 360 degrees to find the maximum reading.
5. The test-receiver system was set to Peak Detect Function and Specified Bandwidth with Maximum Hold Mode.
6. If the emission level of the EUT in peak mode was 10 dB lower than the limit specified, then testing could be stopped and the peak values of the EUT would be reported. Otherwise the emissions that did not have 10 dB margin would be re-tested one by one using peak, quasi-peak or average method as specified and then reported in a data sheet.

Remark :

1. *The resolution bandwidth and video bandwidth of test receiver/spectrum analyzer is 120 KHz for Peak detection (PK) and Quasi-peak detection (QP) at frequency below 1GHz.*
2. *The resolution bandwidth and video bandwidth of test receiver/spectrum analyzer is 1 MHz for Peak detection and frequency above 1GHz.*
3. *The resolution bandwidth of test receiver/spectrum analyzer is 1 MHz and the video bandwidth is 10 Hz for Average detection (AV) at frequency above 1GHz.*



TEST RESULTS

Above 30 MHz

Product Name	DreamTab HD8	Test By	Alan Wu
Test Model	DMTAB-IN08A	Test Date	2014/04/14
Test Mode	Normal Operating + Link Notebook PC Write	Temp. & Humidity	25°C, 58%

966 Chamber_A at 3Meter / Horizontal						
Frequency (MHz)	Reading (dBµV)	Correction Factor (dB/m)	Result (dBµV/m)	Limit (dBµV/m)	Margin (dB)	Remark
62.98	38.07	-10.67	27.40	40.00	-12.60	Peak
167.74	38.10	-10.44	27.66	43.50	-15.84	Peak
239.52	42.72	-11.16	31.56	46.00	-14.44	Peak
299.66	45.81	-8.95	36.86	46.00	-9.14	Peak
482.02	39.22	-4.26	34.96	46.00	-11.04	Peak
621.70	33.77	-1.54	32.23	46.00	-13.77	Peak
780.78	31.53	1.31	32.83	46.00	-13.17	Peak
840.92	32.74	2.08	34.82	46.00	-11.18	Peak
910.76	28.00	3.58	31.58	46.00	-14.42	Peak

966 Chamber_A at 3Meter / Vertical						
Frequency (MHz)	Reading (dBµV)	Correction Factor (dB/m)	Result (dBµV/m)	Limit (dBµV/m)	Margin (dB)	Remark
61.04	37.07	-10.17	26.90	40.00	-13.10	Peak
159.98	39.16	-9.89	29.27	43.50	-14.23	Peak
299.66	37.59	-8.95	28.65	46.00	-17.35	Peak
482.02	39.84	-4.26	35.58	46.00	-10.42	Peak
600.36	35.56	-1.83	33.73	46.00	-12.27	Peak
840.92	37.26	2.08	39.35	46.00	-6.65	Peak
961.20	31.73	4.34	36.07	54.00	-17.93	Peak
1000.00	31.75	4.76	36.51	74.00	-37.49	Peak

Remark:

1. Quasi-peak test would be performed if the peak result were greater than the quasi-peak limit.
2. Data of measurement within this frequency range shown " --- " in the table above means the reading of emissions are attenuated more than 20dB below the permissible limits or the field strength is too small to be measured.
3. Correction Factor (dB/m) = Antenna Factor (dB/m) + Cable Loss (dB) – PreAmp.Gain (dB)
4. Result (dBµV/m) = Reading (dBµV) + Correction Factor (dB/m)
5. Margin (dB) = Remark result (dBµV/m) - Quasi-peak limit (dBµV/m).



7.2 CONDUCTED EMISSION

LIMITS

§ 15.207 (a) Except as shown in paragraph (b) and (c) this section, for an intentional radiator that is designed to be connected to the public utility (AC) power line, the radio frequency voltage that is conducted back onto the AC power line on any frequency or frequencies within the band 150 kHz to 30 MHz shall not exceed the limits in the following table, as measured using a 50 µH/50 ohms line impedance stabilization network (LISN). Compliance with the provisions of this paragraph shall be based on the measurement of the radio frequency voltage between each power line and ground at the power terminal. The lower limit applies at the boundary between the frequency ranges.

Frequency Range (MHz)	Conducted Limit (dBµv)	
	Quasi-peak	Average
0.15 - 0.50	66 to 56	56 to 46
0.50 - 5.00	56	46
5.00 - 30.0	60	50

TEST EQUIPMENT

Name of Equipment	Manufacturer	Model	Serial Number	Calibration Due
L.I.S.N	SCHWARZBECK	NSLK 8127	8127-465	08/11/2014
L.I.S.N	SCHWARZBECK	NSLK 8127	8127-473	03/10/2015
EMI Receiver	ROHDE & SCHWARZ	ESCS 30	835418/008	10/16/2014
Pulse Limiter	ROHDE & SCHWARZ	ESH3-Z2	100117	07/01/2014

Remark: Each piece of equipment is scheduled for calibration once a year.



TEST SETUP

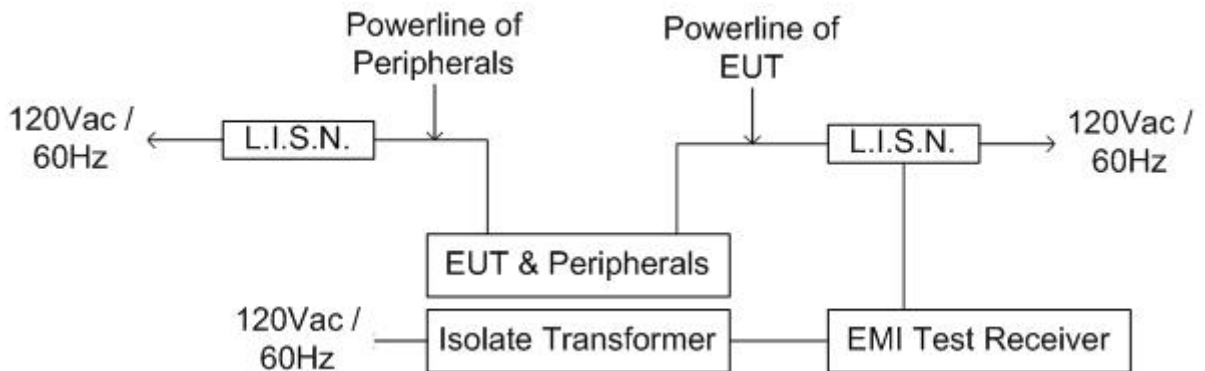
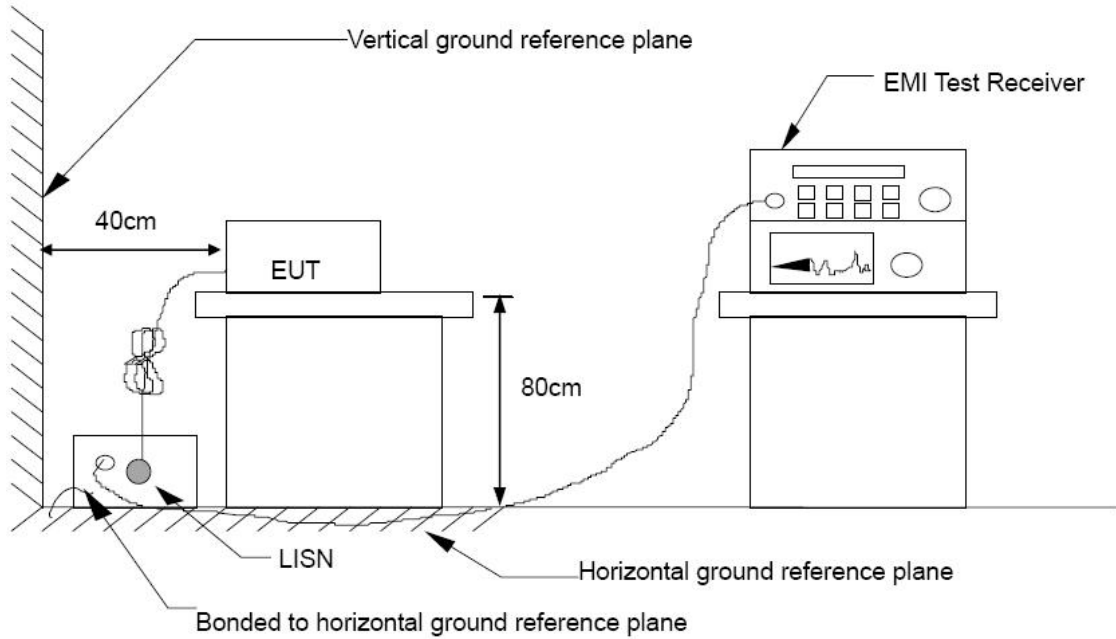



TEST PROCEDURE

The basic test procedure was in accordance with ANSI C63.4:2009.

The test procedure is performed in a 4m × 3m × 2.4m (L×W×H) shielded room.

The EUT along with its peripherals were placed on a 1.0m (W) × 1.5m (L) and 0.8m in height wooden table and the EUT was adjusted to maintain a 0.4 meter space from a vertical reference plane.

The EUT was connected to power mains through a line impedance stabilization network (LISN) which provides 50 ohm coupling impedance for measuring instrument and the chassis ground was bounded to the horizontal ground plane of shielded room. All peripherals were connected to the second LISN and the chassis ground also bounded to the horizontal ground plane of shielded room.

The EUT was located so that the distance between the boundary of the EUT and the closest surface of the LISN is 0.8 m. Where a mains flexible cord was provided by the manufacturer shall be 1 m long, or if in excess of 1 m, the excess cable was folded back and forth as far as possible so as to form a bundle not exceeding 0.4 m in length.



TEST RESULTS

Product Name	DreamTab HD8	Test By	Alan Wu
Test Model	DMTAB-IN08A	Test Date	2014/04/14
Test Mode	Charge Mode + Play Video	Temp. & Humidity	21°C, 50%

LINE

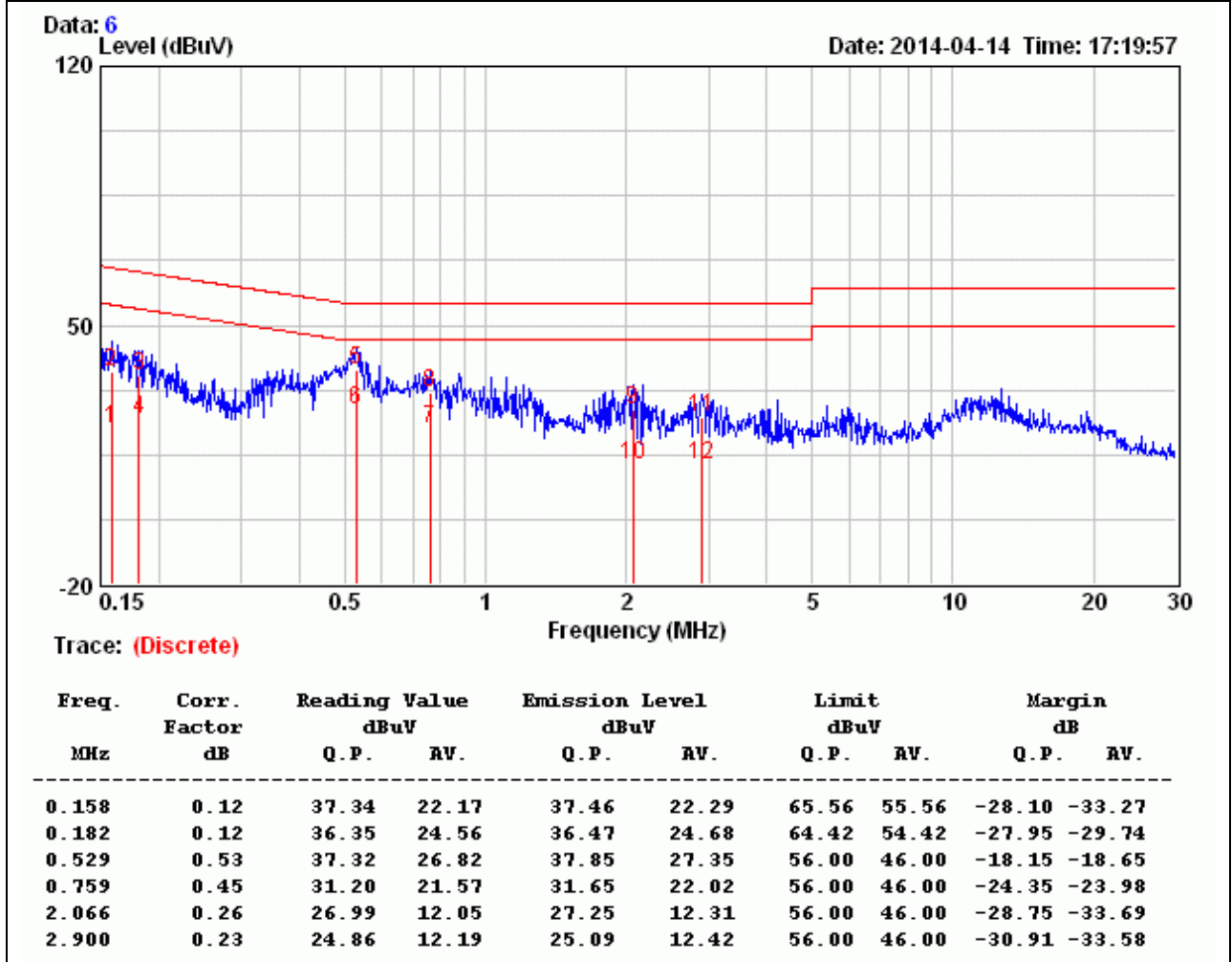

Remark:

1. Correction Factor = Insertion loss + Cable loss
2. Emission level = Reading Value + Correction factor
3. Margin value = Emission level - Limit value



Product Name	DreamTab HD8	Test By	Alan Wu
Test Model	DMTAB-IN08A	Test Date	2014/04/14
Test Mode	Charge Mode + Play Video	Temp. & Humidity	21 °C, 50%

NEUTRAL

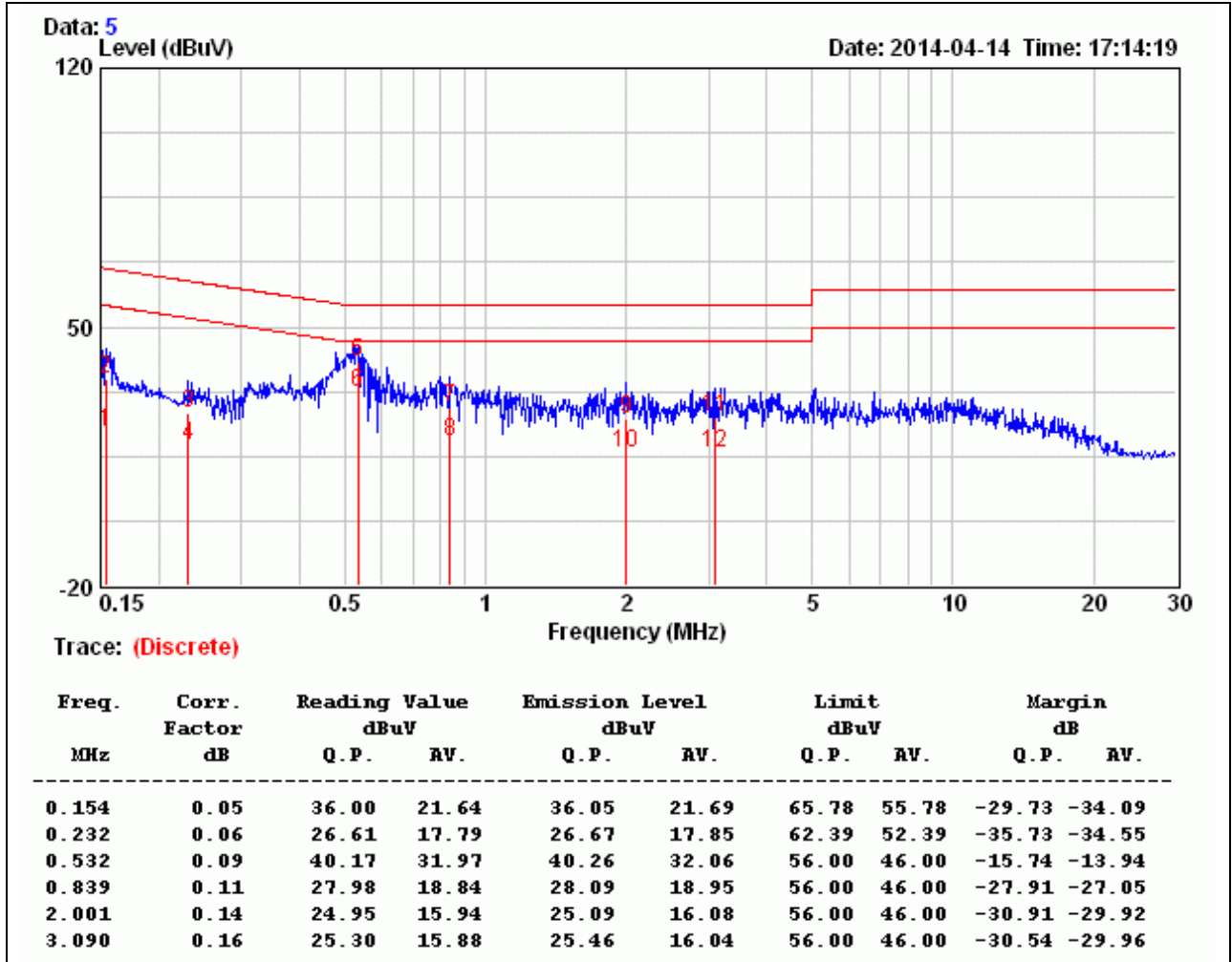

Remark:

1. Correction Factor = Insertion loss + Cable loss
2. Emission level = Reading Value + Correction factor
3. Margin value = Emission level – Limit value