

APPENDIX A: TEST DATA
Liquid Level Photo

MSL 2450MHz D=152mm



Test Laboratory: Advance Data Technology

N800C-11b-CH 1-M01

DUT: 802.11n/g/b Wireless USB Compact Adapter ; Type: WUB-370L ; Test Frequency: 2412 MHz

Communication System: 802.11b ; Frequency: 2412 MHz ; Duty Cycle: 1:1 ; Modulation type: DBPSK

Medium: MSL2450 Medium parameters used: $f = 2412$ MHz; $\sigma = 1.87$ mho/m; $\epsilon_r = 53$; $\rho = 1000$

kg/m³ ; Liquid level : 152 mm

Phantom section: Flat Section ; Separation distance : 10 mm (The bottom side of the EUT to the Phantom)

Antenna type : Printed Antenna ; Air temp. : 23.5 degrees ; Liquid temp. : 22.3 degrees

DASY4 Configuration:

- Probe: ET3DV6 - SN1790 ; ConvF(4.35, 4.35, 4.35) ; Calibrated: 2006/11/23

- Sensor-Surface: 4mm (Mechanical Surface Detection)

- Electronics: DAE3 Sn510 ; Calibrated: 2006/9/7

- Phantom: SAM 12 ; Type: SAM V4.0 ; Serial: TP 1202

- Measurement SW: DASY4, V4.7 Build 53 ; Postprocessing SW: SEMCAD, V1.8 Build 172

Low Channel 1/Area Scan (5x9x1): Measurement grid: dx=15mm, dy=15mm

Maximum value of SAR (measured) = 0.248 mW/g

Low Channel 1/Zoom Scan (7x7x7)/Cube 0: Measurement grid: dx=5mm, dy=5mm, dz=5mm

Reference Value = 11.2 V/m

Peak SAR (extrapolated) = 0.703 W/kg

SAR(1 g) = 0.270 mW/g; SAR(10 g) = 0.128 mW/g

Maximum value of SAR (measured) = 0.283 mW/g

Low Channel 1/Zoom Scan (7x7x7)/Cube 1: Measurement grid: dx=5mm, dy=5mm, dz=5mm

Reference Value = 11.2 V/m

Peak SAR (extrapolated) = 0.427 W/kg

SAR(1 g) = 0.196 mW/g; SAR(10 g) = 0.106 mW/g

Maximum value of SAR (measured) = 0.207 mW/g

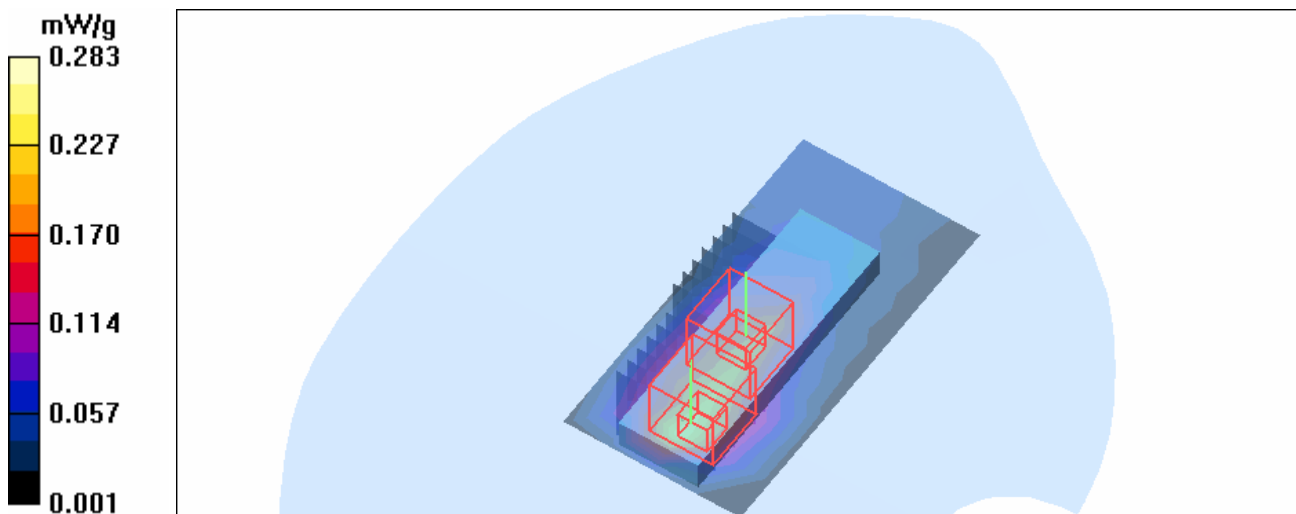

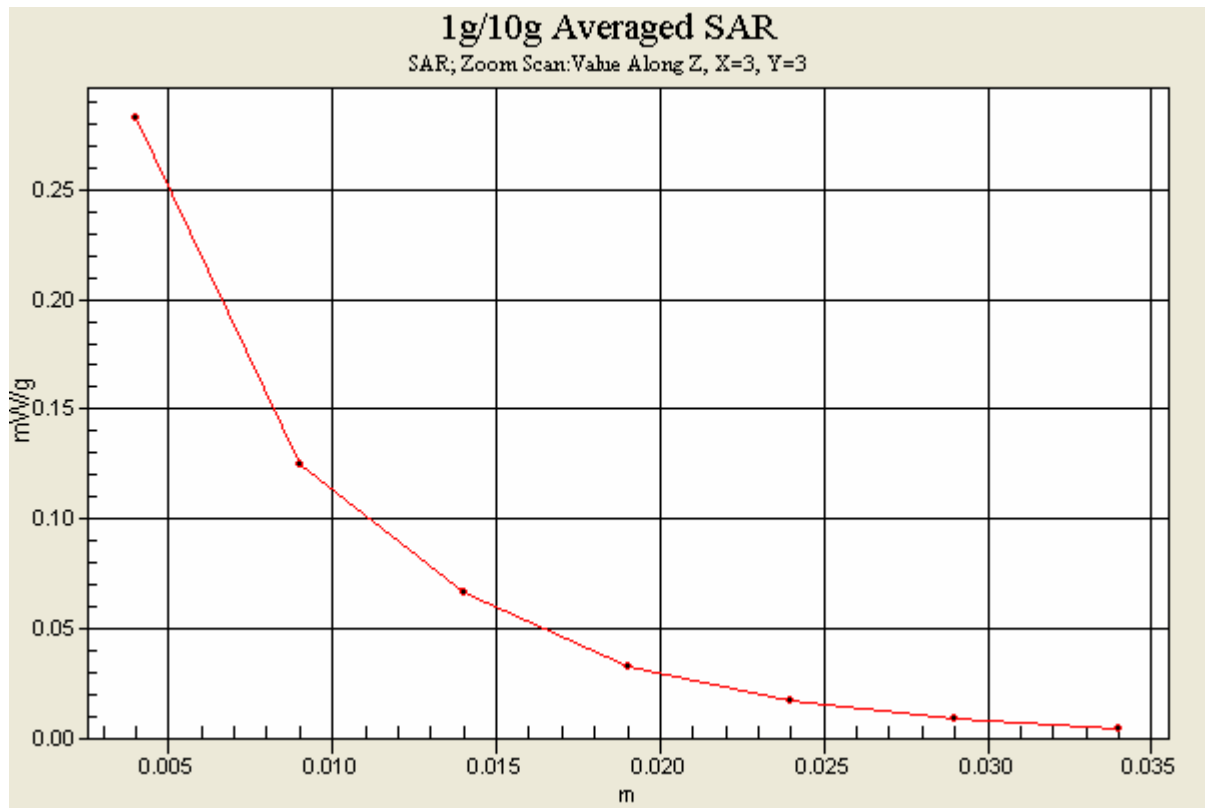

Test Laboratory: Advance Data Technology

N800C-11b-CH 6-M01

DUT: 802.11n/g/b Wireless USB Compact Adapter ; Type: WUB-370L ; Test Frequency: 2437 MHz

Communication System: 802.11b ; Frequency: 2437 MHz ; Duty Cycle: 1:1 ; Modulation type: DBPSK

Medium: MSL2450 Medium parameters used: $f = 2437$ MHz; $\sigma = 1.9$ mho/m; $\epsilon_r = 52.9$; $\rho = 1000$

kg/m³ ; Liquid level : 152 mm

Phantom section: Flat Section ; Separation distance : 10 mm (The bottom side of the EUT to the Phantom)

Antenna type : Printed Antenna ; Air temp. : 23.5 degrees ; Liquid temp. : 22.3 degrees

DASY4 Configuration:

- Probe: ET3DV6 - SN1790 ; ConvF(4.35, 4.35, 4.35) ; Calibrated: 2006/11/23

- Sensor-Surface: 4mm (Mechanical Surface Detection)

- Electronics: DAE3 Sn510 ; Calibrated: 2006/9/7

- Phantom: SAM 12 ; Type: SAM V4.0 ; Serial: TP 1202

- Measurement SW: DASY4, V4.7 Build 53 ; Postprocessing SW: SEMCAD, V1.8 Build 172

Mid Channel 6/Area Scan (5x9x1): Measurement grid: dx=15mm, dy=15mm

Maximum value of SAR (measured) = 0.239 mW/g

Mid Channel 6/Zoom Scan (7x7x7)/Cube 0: Measurement grid: dx=5mm, dy=5mm, dz=5mm

Reference Value = 10.9 V/m

Peak SAR (extrapolated) = 0.662 W/kg

SAR(1 g) = 0.253 mW/g; SAR(10 g) = 0.119 mW/g

Maximum value of SAR (measured) = 0.273 mW/g

Mid Channel 6/Zoom Scan (7x7x7)/Cube 1: Measurement grid: dx=5mm, dy=5mm, dz=5mm

Reference Value = 10.9 V/m

Peak SAR (extrapolated) = 0.382 W/kg

SAR(1 g) = 0.169 mW/g; SAR(10 g) = 0.092 mW/g

Maximum value of SAR (measured) = 0.179 mW/g

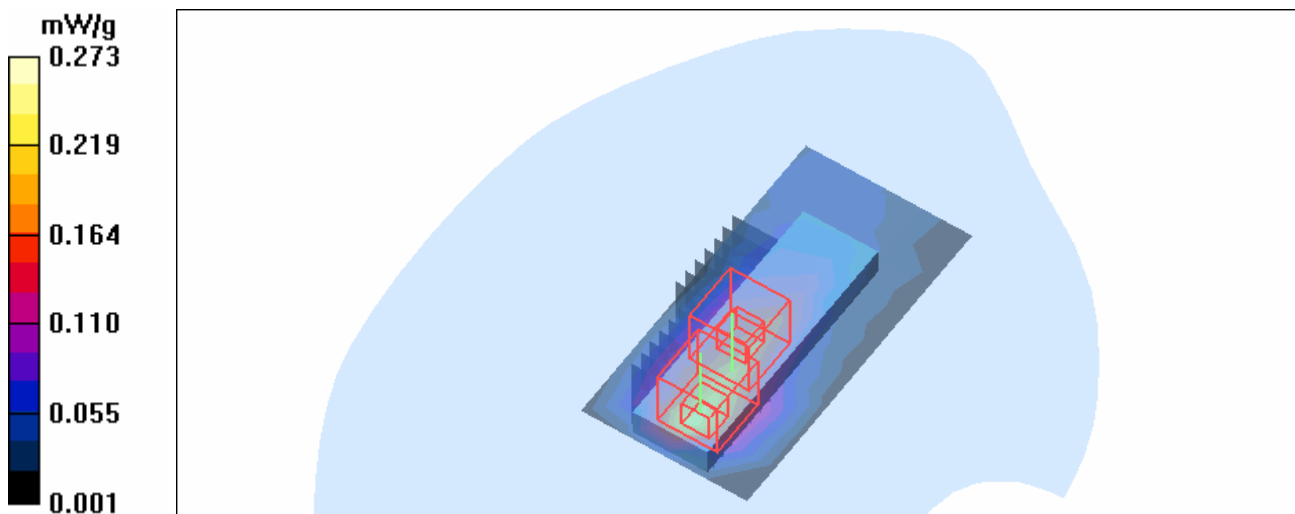

Test Laboratory: Advance Data Technology

N800C-11b-CH 11-M01

DUT: 802.11n/g/b Wireless USB Compact Adapter ; Type: WUB-370L ; Test Frequency: 2462 MHz
 Communication System: 802.11b ; Frequency: 2462 MHz ; Duty Cycle: 1:1 ; Modulation type: DBPSK
 Medium: MSL2450 Medium parameters used: $f = 2462 \text{ MHz}$; $\sigma = 1.93 \text{ mho/m}$; $\epsilon_r = 52.7$; $\rho = 1000 \text{ kg/m}^3$; Liquid level : 152 mm
 Phantom section: Flat Section ; Separation distance : 10 mm (The bottom side of the EUT to the Phantom)
 Antenna type : Printed Antenna ; Air temp. : 23.5 degrees ; Liquid temp. : 22.3 degrees

DASY4 Configuration:

- Probe: ET3DV6 - SN1790 ; ConvF(4.35, 4.35, 4.35) ; Calibrated: 2006/11/23
- Sensor-Surface: 4mm (Mechanical Surface Detection)
- Electronics: DAE3 Sn510 ; Calibrated: 2006/9/7
- Phantom: SAM 12 ; Type: SAM V4.0 ; Serial: TP 1202
- Measurement SW: DASY4, V4.7 Build 53 ; Postprocessing SW: SEMCAD, V1.8 Build 172

High Channel 11/Area Scan (5x9x1): Measurement grid: $dx=15\text{mm}$, $dy=15\text{mm}$
 Maximum value of SAR (measured) = 0.218 mW/g

High Channel 11/Zoom Scan (7x7x7)/Cube 0: Measurement grid: $dx=5\text{mm}$, $dy=5\text{mm}$, $dz=5\text{mm}$
 Reference Value = 10.3 V/m
 Peak SAR (extrapolated) = 0.598 W/kg
SAR(1 g) = 0.229 mW/g; SAR(10 g) = 0.108 mW/g
 Maximum value of SAR (measured) = 0.242 mW/g

High Channel 11/Zoom Scan (7x7x7)/Cube 1: Measurement grid: $dx=5\text{mm}$, $dy=5\text{mm}$, $dz=5\text{mm}$
 Reference Value = 10.3 V/m
 Peak SAR (extrapolated) = 0.361 W/kg
SAR(1 g) = 0.142 mW/g; SAR(10 g) = 0.078 mW/g
 Maximum value of SAR (measured) = 0.153 mW/g

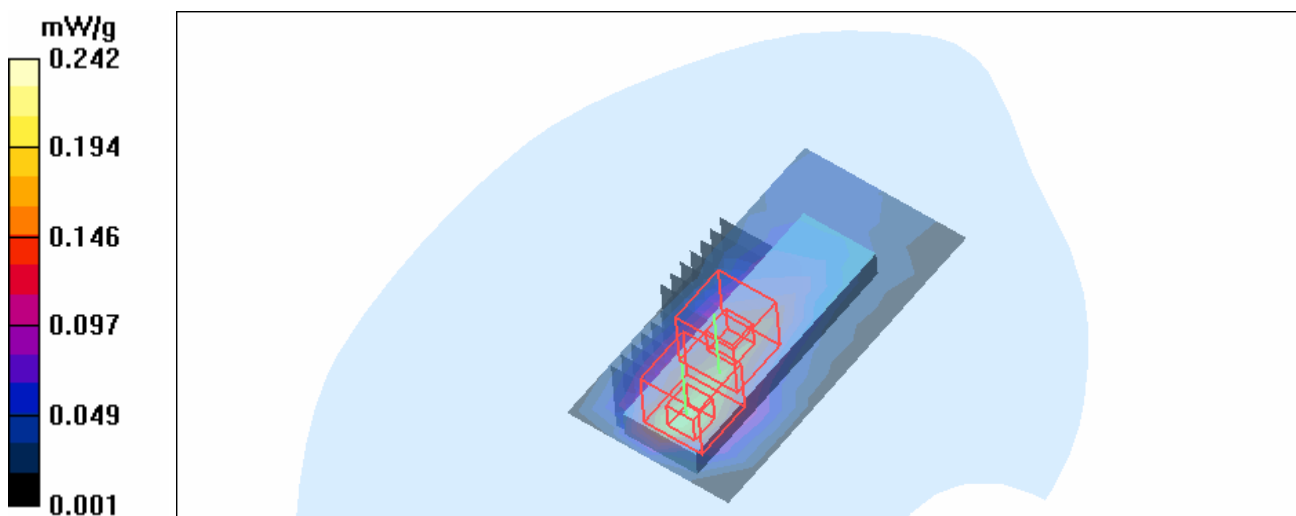

Test Laboratory: Advance Data Technology

N800C-11g-CH 1-M02

DUT: 802.11n/g/b Wireless USB Compact Adapter ; Type: WUB-370L ; Test Frequency: 2412 MHz
 Communication System: 802.11g ; Frequency: 2412 MHz ; Duty Cycle: 1:1 ; Modulation type: BPSK
 Medium: MSL2450 Medium parameters used: $f = 2412$ MHz; $\sigma = 1.87$ mho/m; $\epsilon_r = 53$; $\rho = 1000$ kg/m³ ; Liquid level : 152 mm
 Phantom section: Flat Section ; Separation distance : 10 mm (The bottom side of the EUT to the Phantom)
 Antenna type : Printed Antenna ; Air temp. : 23.5 degrees ; Liquid temp. : 22.3 degrees

DASY4 Configuration:

- Probe: ET3DV6 - SN1790 ; ConvF(4.35, 4.35, 4.35) ; Calibrated: 2006/11/23
- Sensor-Surface: 4mm (Mechanical Surface Detection)
- Electronics: DAE3 Sn510 ; Calibrated: 2006/9/7
- Phantom: SAM 12 ; Type: SAM V4.0 ; Serial: TP 1202
- Measurement SW: DASY4, V4.7 Build 53 ; Postprocessing SW: SEMCAD, V1.8 Build 172

Low Channel 1/Area Scan (5x9x1): Measurement grid: dx=15mm, dy=15mm
 Maximum value of SAR (measured) = 0.068 mW/g

Low Channel 1/Zoom Scan (7x7x7)/Cube 0: Measurement grid: dx=5mm, dy=5mm, dz=5mm
 Reference Value = 5.80 V/m
 Peak SAR (extrapolated) = 0.183 W/kg
SAR(1 g) = 0.071 mW/g; SAR(10 g) = 0.034 mW/g
 Maximum value of SAR (measured) = 0.075 mW/g

Low Channel 1/Zoom Scan (7x7x7)/Cube 1: Measurement grid: dx=5mm, dy=5mm, dz=5mm
 Reference Value = 5.80 V/m
 Peak SAR (extrapolated) = 0.113 W/kg
SAR(1 g) = 0.052 mW/g; SAR(10 g) = 0.029 mW/g
 Maximum value of SAR (measured) = 0.055 mW/g

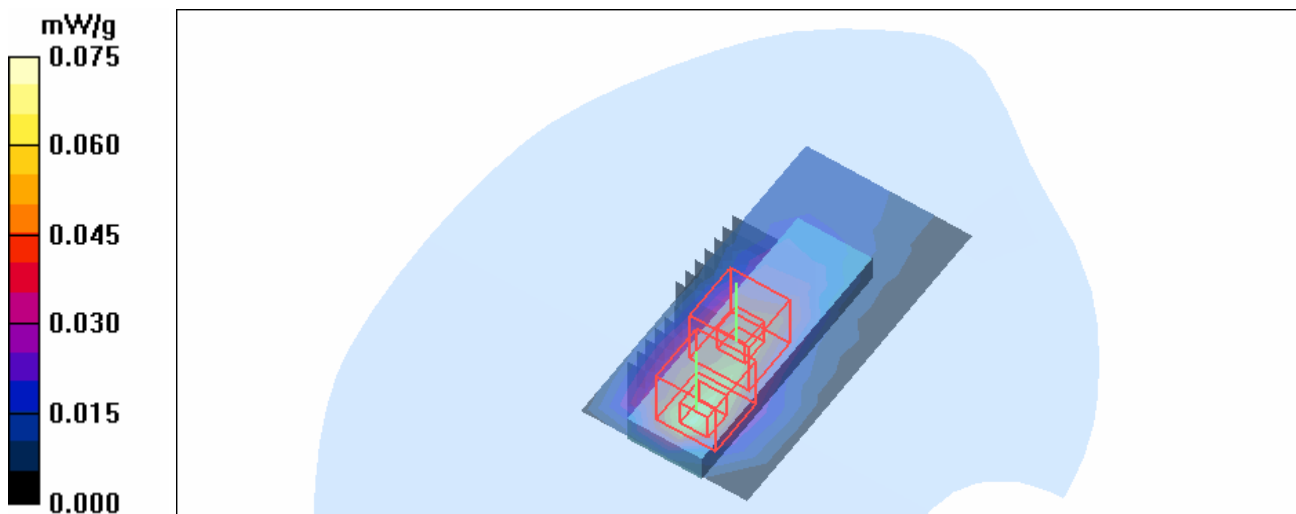

Test Laboratory: Advance Data Technology

N800C-11g-CH 6-M02

DUT: 802.11n/g/b Wireless USB Compact Adapter ; Type: WUB-370L ; Test Frequency: 2437 MHz

Communication System: 802.11g ; Frequency: 2437 MHz ; Duty Cycle: 1:1 ; Modulation type: BPSK

Medium: MSL2450 Medium parameters used: $f = 2437$ MHz; $\sigma = 1.9$ mho/m; $\epsilon_r = 52.9$; $\rho = 1000$ kg/m³ ; Liquid level : 152 mm

Phantom section: Flat Section ; Separation distance : 10 mm (The bottom side of the EUT to the Phantom)

Antenna type : Printed Antenna ; Air temp. : 23.5 degrees ; Liquid temp. : 22.3 degrees

DASY4 Configuration:

- Probe: ET3DV6 - SN1790 ; ConvF(4.35, 4.35, 4.35) ; Calibrated: 2006/11/23

- Sensor-Surface: 4mm (Mechanical Surface Detection)

- Electronics: DAE3 Sn510 ; Calibrated: 2006/9/7

- Phantom: SAM 12 ; Type: SAM V4.0 ; Serial: TP 1202

- Measurement SW: DASY4, V4.7 Build 53 ; Postprocessing SW: SEMCAD, V1.8 Build 172

Mid Channel 6/Area Scan (5x9x1): Measurement grid: dx=15mm, dy=15mm

Maximum value of SAR (measured) = 0.070 mW/g

Mid Channel 6/Zoom Scan (7x7x7)/Cube 0: Measurement grid: dx=5mm, dy=5mm, dz=5mm

Reference Value = 5.98 V/m

Peak SAR (extrapolated) = 0.186 W/kg

SAR(1 g) = 0.073 mW/g; SAR(10 g) = 0.035 mW/g

Maximum value of SAR (measured) = 0.077 mW/g

Mid Channel 6/Zoom Scan (7x7x7)/Cube 1: Measurement grid: dx=5mm, dy=5mm, dz=5mm

Reference Value = 5.98 V/m

Peak SAR (extrapolated) = 0.108 W/kg

SAR(1 g) = 0.049 mW/g; SAR(10 g) = 0.027 mW/g

Maximum value of SAR (measured) = 0.052 mW/g

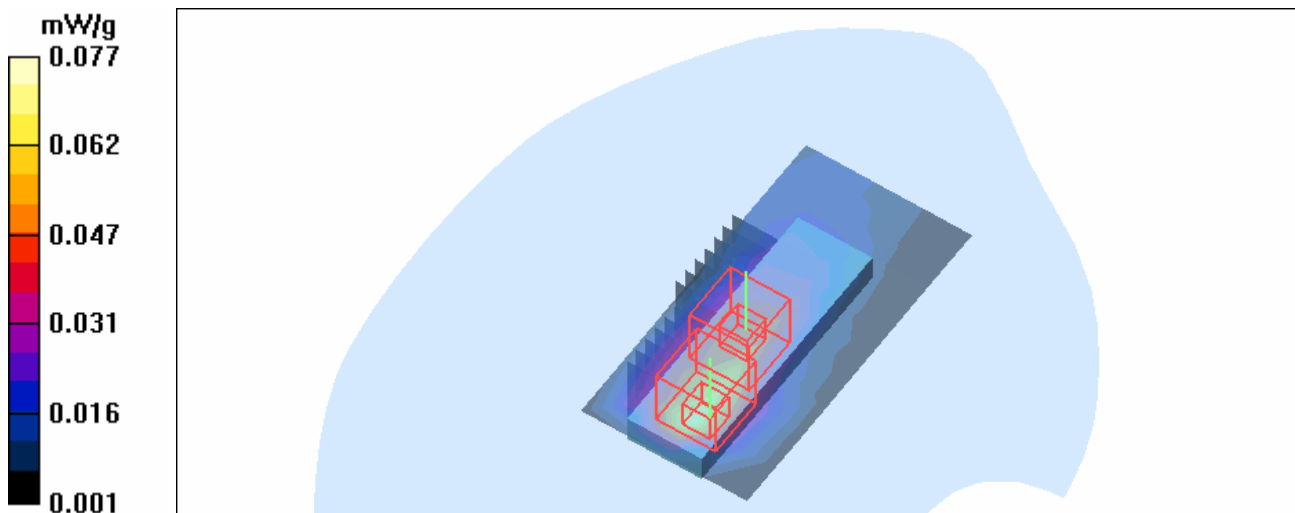

Test Laboratory: Advance Data Technology

N800C-11g-CH 11-M02

DUT: 802.11n/g/b Wireless USB Compact Adapter ; Type: WUB-370L ; Test Frequency: 2462 MHz

Communication System: 802.11g ; Frequency: 2462 MHz ; Duty Cycle: 1:1 ; Modulation type: BPSK

Medium: MSL2450 Medium parameters used: $f = 2462$ MHz; $\sigma = 1.93$ mho/m; $\epsilon_r = 52.7$; $\rho = 1000$ kg/m³ ; Liquid level : 152 mm

Phantom section: Flat Section ; Separation distance : 10 mm (The bottom side of the EUT to the Phantom)

Antenna type : Printed Antenna ; Air temp. : 23.5 degrees ; Liquid temp. : 22.3 degrees

DASY4 Configuration:

- Probe: ET3DV6 - SN1790 ; ConvF(4.35, 4.35, 4.35) ; Calibrated: 2006/11/23

- Sensor-Surface: 4mm (Mechanical Surface Detection)

- Electronics: DAE3 Sn510 ; Calibrated: 2006/9/7

- Phantom: SAM 12 ; Type: SAM V4.0 ; Serial: TP 1202

- Measurement SW: DASY4, V4.7 Build 53 ; Postprocessing SW: SEMCAD, V1.8 Build 172

High Channel 11/Area Scan (5x9x1): Measurement grid: dx=15mm, dy=15mm

Maximum value of SAR (measured) = 0.059 mW/g

High Channel 11/Zoom Scan (7x7x7)/Cube 0: Measurement grid: dx=5mm, dy=5mm, dz=5mm

Reference Value = 5.41 V/m

Peak SAR (extrapolated) = 0.161 W/kg

SAR(1 g) = 0.062 mW/g; SAR(10 g) = 0.029 mW/g

Maximum value of SAR (measured) = 0.065 mW/g

High Channel 11/Zoom Scan (7x7x7)/Cube 1: Measurement grid: dx=5mm, dy=5mm, dz=5mm

Reference Value = 5.41 V/m

Peak SAR (extrapolated) = 0.088 W/kg

SAR(1 g) = 0.039 mW/g; SAR(10 g) = 0.018 mW/g

Maximum value of SAR (measured) = 0.032 mW/g

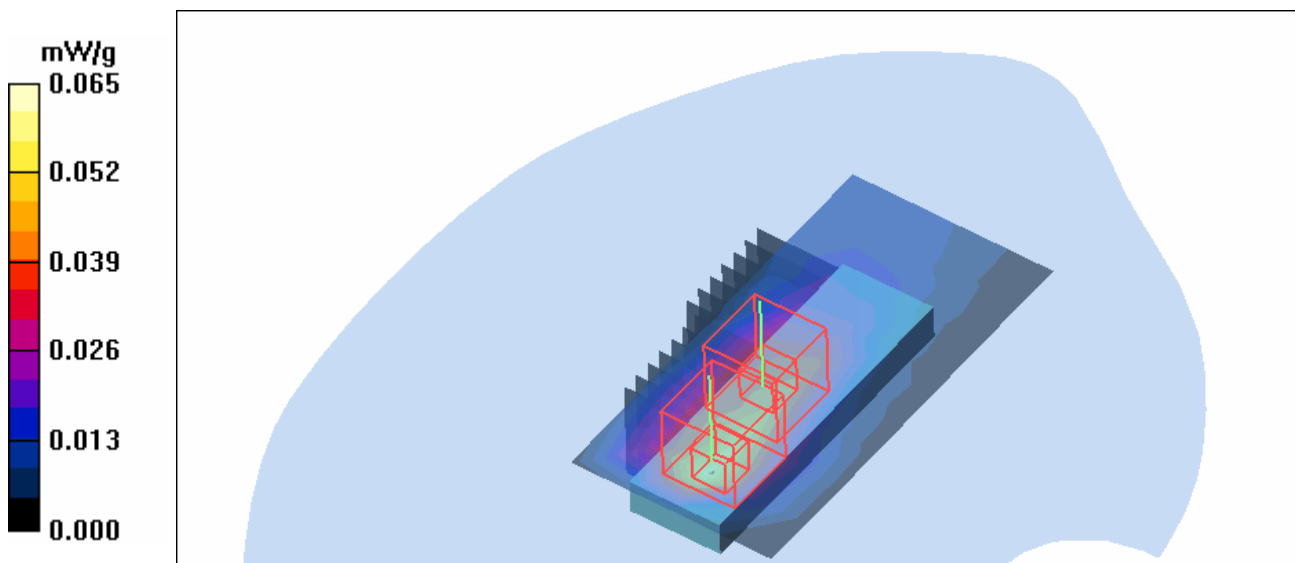

Test Laboratory: Advance Data Technology

N800C-11n span 20MHz-CH 1-M03

DUT: 802.11n/g/b Wireless USB Compact Adapter ; Type: WUB-370L ; Test Frequency: 2412 MHz

Communication System: 2.4G 11n span20 ; Frequency: 2412 MHz ; Duty Cycle: 1:1 ; Modulation type: BPSK

Medium: MSL2450 Medium parameters used: $f = 2412 \text{ MHz}$; $\sigma = 1.87 \text{ mho/m}$; $\epsilon_r = 53$; $\rho = 1000 \text{ kg/m}^3$; Liquid level : 152 mm

Phantom section: Flat Section ; Separation distance : 10 mm (The bottom side of the EUT to the Phantom)

Antenna type : Printed Antenna ; Air temp. : 23.5 degrees ; Liquid temp. : 22.3 degrees

DASY4 Configuration:

- Probe: ET3DV6 - SN1790 ; ConvF(4.35, 4.35, 4.35) ; Calibrated: 2006/11/23
- Sensor-Surface: 4mm (Mechanical Surface Detection)
- Electronics: DAE3 Sn510 ; Calibrated: 2006/9/7
- Phantom: SAM 12 ; Type: SAM V4.0 ; Serial: TP 1202
- Measurement SW: DASY4, V4.7 Build 53 ; Postprocessing SW: SEMCAD, V1.8 Build 172

Low Channel 1/Area Scan (5x9x1): Measurement grid: $dx=15\text{mm}$, $dy=15\text{mm}$

Maximum value of SAR (measured) = 0.102 mW/g

Low Channel 1/Zoom Scan (7x7x7)/Cube 0: Measurement grid: $dx=5\text{mm}$, $dy=5\text{mm}$, $dz=5\text{mm}$

Reference Value = 7.03 V/m

Peak SAR (extrapolated) = 0.257 W/kg

SAR(1 g) = 0.107 mW/g; SAR(10 g) = 0.054 mW/g

Maximum value of SAR (measured) = 0.114 mW/g

Low Channel 1/Zoom Scan (7x7x7)/Cube 1: Measurement grid: $dx=5\text{mm}$, $dy=5\text{mm}$, $dz=5\text{mm}$

Reference Value = 7.03 V/m

Peak SAR (extrapolated) = 0.170 W/kg

SAR(1 g) = 0.081 mW/g; SAR(10 g) = 0.044 mW/g

Maximum value of SAR (measured) = 0.086 mW/g

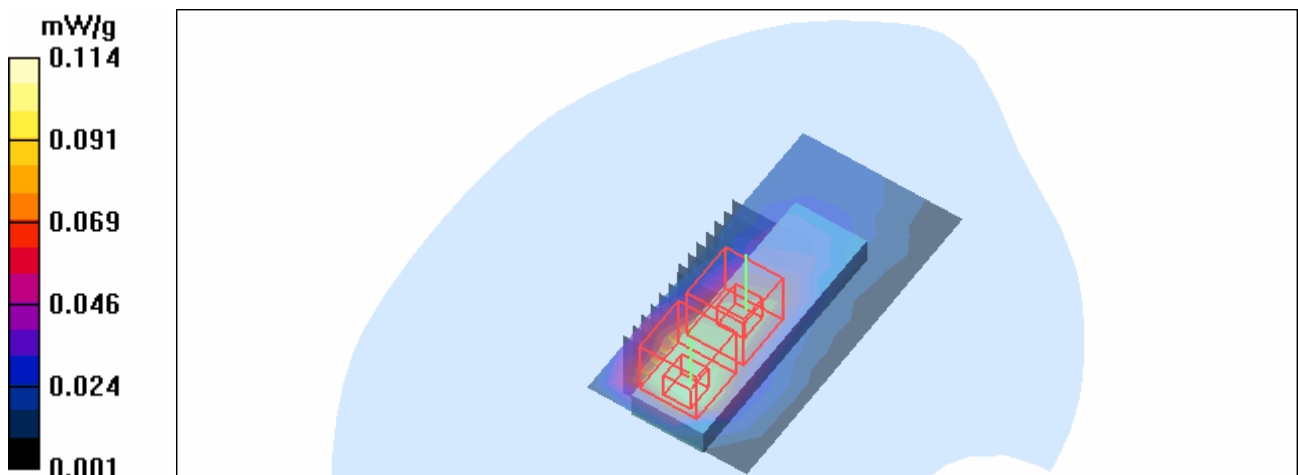

Test Laboratory: Advance Data Technology

N800C-11n span 20MHz-CH 6-M03

DUT: 802.11n/g/b Wireless USB Compact Adapter ; Type: WUB-370L ; Test Frequency: 2437 MHz

Communication System: 2.4G 11n span20 ; Frequency: 2437 MHz ; Duty Cycle: 1:1 ; Modulation type: BPSK

Medium: MSL2450 Medium parameters used: $f = 2437 \text{ MHz}$; $\sigma = 1.9 \text{ mho/m}$; $\epsilon_r = 52.9$; $\rho = 1000 \text{ kg/m}^3$; Liquid level : 152 mm

Phantom section: Flat Section ; Separation distance : 10 mm (The bottom side of the EUT to the Phantom)

Antenna type : Printed Antenna ; Air temp. : 23.5 degrees ; Liquid temp. : 22.3 degrees

DASY4 Configuration:

- Probe: ET3DV6 - SN1790 ; ConvF(4.35, 4.35, 4.35) ; Calibrated: 2006/11/23
- Sensor-Surface: 4mm (Mechanical Surface Detection)
- Electronics: DAE3 Sn510 ; Calibrated: 2006/9/7
- Phantom: SAM 12 ; Type: SAM V4.0 ; Serial: TP 1202
- Measurement SW: DASY4, V4.7 Build 53 ; Postprocessing SW: SEMCAD, V1.8 Build 172

Mid Channel 6/Area Scan (5x9x1): Measurement grid: $dx=15\text{mm}$, $dy=15\text{mm}$

Maximum value of SAR (measured) = 0.104 mW/g

Mid Channel 6/Zoom Scan (7x7x7)/Cube 0: Measurement grid: $dx=5\text{mm}$, $dy=5\text{mm}$, $dz=5\text{mm}$

Reference Value = 7.25 V/m

Peak SAR (extrapolated) = 0.264 W/kg

SAR(1 g) = 0.110 mW/g; SAR(10 g) = 0.056 mW/g

Maximum value of SAR (measured) = 0.117 mW/g

Mid Channel 6/Zoom Scan (7x7x7)/Cube 1: Measurement grid: $dx=5\text{mm}$, $dy=5\text{mm}$, $dz=5\text{mm}$

Reference Value = 7.25 V/m

Peak SAR (extrapolated) = 0.174 W/kg

SAR(1 g) = 0.083 mW/g; SAR(10 g) = 0.045 mW/g

Maximum value of SAR (measured) = 0.089 mW/g

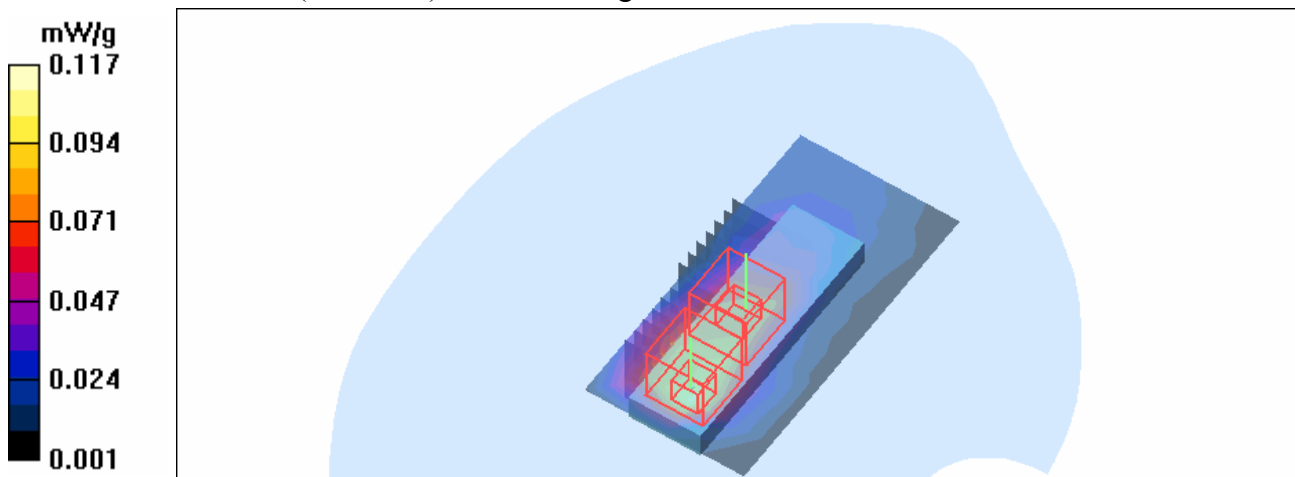

Test Laboratory: Advance Data Technology

N800C-11n span 20MHz-CH 11-M03

DUT: 802.11n/g/b Wireless USB Compact Adapter ; Type: WUB-370L ; Test Frequency: 2462 MHz

Communication System: 2.4G 11n span20 ; Frequency: 2462 MHz ; Duty Cycle: 1:1 ; Modulation type: BPSK

Medium: MSL2450 Medium parameters used: $f = 2462$ MHz; $\sigma = 1.93$ mho/m; $\epsilon_r = 52.7$; $\rho = 1000$ kg/m³ ; Liquid level : 152 mm

Phantom section: Flat Section ; Separation distance : 10 mm (The bottom side of the EUT to the Phantom)

Antenna type : Printed Antenna ; Air temp. : 23.5 degrees ; Liquid temp. : 22.3 degrees

DASY4 Configuration:

- Probe: ET3DV6 - SN1790 ; ConvF(4.35, 4.35, 4.35) ; Calibrated: 2006/11/23
- Sensor-Surface: 4mm (Mechanical Surface Detection)
- Electronics: DAE3 Sn510 ; Calibrated: 2006/9/7
- Phantom: SAM 12 ; Type: SAM V4.0 ; Serial: TP 1202
- Measurement SW: DASY4, V4.7 Build 53 ; Postprocessing SW: SEMCAD, V1.8 Build 172

High Channel 11/Area Scan (5x9x1): Measurement grid: dx=15mm, dy=15mm

Maximum value of SAR (measured) = 0.082 mW/g

High Channel 11/Zoom Scan (7x7x7)/Cube 0: Measurement grid: dx=5mm, dy=5mm, dz=5mm

Reference Value = 6.89 V/m

Peak SAR (extrapolated) = 0.243 W/kg

SAR(1 g) = 0.098 mW/g; SAR(10 g) = 0.047 mW/g

Maximum value of SAR (measured) = 0.105 mW/g

High Channel 11/Zoom Scan (7x7x7)/Cube 1: Measurement grid: dx=5mm, dy=5mm, dz=5mm

Reference Value = 6.89 V/m

Peak SAR (extrapolated) = 0.165 W/kg

SAR(1 g) = 0.072 mW/g; SAR(10 g) = 0.032 mW/g

Maximum value of SAR (measured) = 0.079 mW/g

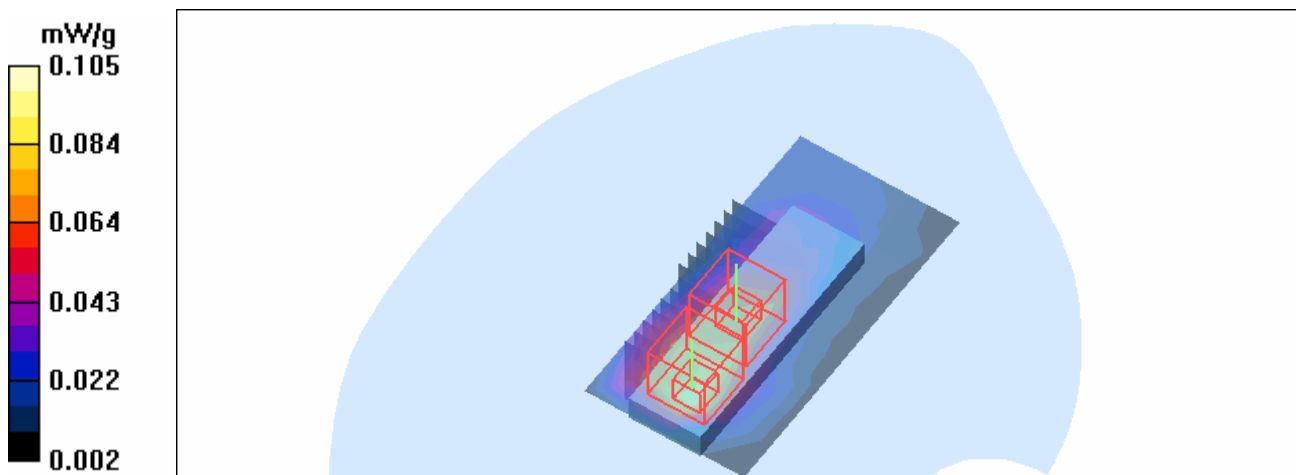

Test Laboratory: Advance Data Technology

N800C-11n span 40MHz-CH 1-M04

DUT: 802.11n/g/b Wireless USB Compact Adapter ; Type: WUB-370L ; Test Frequency: 2422 MHz

Communication System: 2.4G 11n span40 ; Frequency: 2422 MHz ; Duty Cycle: 1:1 ; Modulation type: BPSK

Medium: MSL2450 Medium parameters used: $f = 2422 \text{ MHz}$; $\sigma = 1.88 \text{ mho/m}$; $\epsilon_r = 52.9$; $\rho = 1000 \text{ kg/m}^3$; Liquid level : 152 mm

Phantom section: Flat Section ; Separation distance : 10 mm (The bottom side of the EUT to the Phantom)

Antenna type : Printed Antenna ; Air temp. : 23.5 degrees ; Liquid temp. : 22.3 degrees

DASY4 Configuration:

- Probe: ET3DV6 - SN1790 ; ConvF(4.35, 4.35, 4.35) ; Calibrated: 2006/11/23
- Sensor-Surface: 4mm (Mechanical Surface Detection)
- Electronics: DAE3 Sn510 ; Calibrated: 2006/9/7
- Phantom: SAM 12 ; Type: SAM V4.0 ; Serial: TP 1202
- Measurement SW: DASY4, V4.7 Build 53 ; Postprocessing SW: SEMCAD, V1.8 Build 172

Low Channel 1/Area Scan (5x9x1): Measurement grid: $dx=15\text{mm}$, $dy=15\text{mm}$

Maximum value of SAR (measured) = 0.044 mW/g

Low Channel 1/Zoom Scan (7x7x7)/Cube 0: Measurement grid: $dx=5\text{mm}$, $dy=5\text{mm}$, $dz=5\text{mm}$

Reference Value = 4.56 V/m

Peak SAR (extrapolated) = 0.111 W/kg

SAR(1 g) = 0.047 mW/g; SAR(10 g) = 0.024 mW/g

Maximum value of SAR (measured) = 0.050 mW/g

Low Channel 1/Zoom Scan (7x7x7)/Cube 1: Measurement grid: $dx=5\text{mm}$, $dy=5\text{mm}$, $dz=5\text{mm}$

Reference Value = 4.56 V/m

Peak SAR (extrapolated) = 0.077 W/kg

SAR(1 g) = 0.036 mW/g; SAR(10 g) = 0.020 mW/g

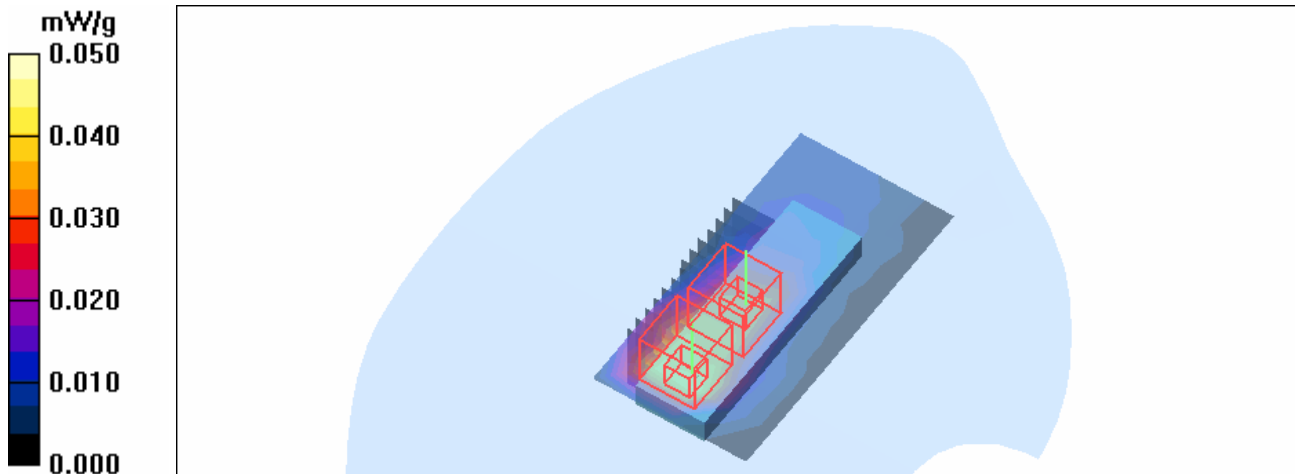

Test Laboratory: Advance Data Technology

N800C-11n span 40MHz-CH 4-M04

DUT: 802.11n/g/b Wireless USB Compact Adapter ; Type: WUB-370L ; Test Frequency: 2437 MHz

Communication System: 2.4G 11n span40 ; Frequency: 2437 MHz ; Duty Cycle: 1:1 ; Modulation type: BPSK

Medium: MSL2450 Medium parameters used: $f = 2437 \text{ MHz}$; $\sigma = 1.9 \text{ mho/m}$; $\epsilon_r = 52.9$; $\rho = 1000 \text{ kg/m}^3$; Liquid level : 152 mm

Phantom section: Flat Section ; Separation distance : 10 mm (The bottom side of the EUT to the Phantom)

Antenna type : Printed Antenna ; Air temp. : 23.5 degrees ; Liquid temp. : 22.3 degrees

DASY4 Configuration:

- Probe: ET3DV6 - SN1790 ; ConvF(4.35, 4.35, 4.35) ; Calibrated: 2006/11/23
- Sensor-Surface: 4mm (Mechanical Surface Detection)
- Electronics: DAE3 Sn510 ; Calibrated: 2006/9/7
- Phantom: SAM 12 ; Type: SAM V4.0 ; Serial: TP 1202
- Measurement SW: DASY4, V4.7 Build 53 ; Postprocessing SW: SEMCAD, V1.8 Build 172

Mid Channel 4/Area Scan (5x9x1): Measurement grid: $dx=15\text{mm}$, $dy=15\text{mm}$

Maximum value of SAR (measured) = 0.062 mW/g

Mid Channel 4/Zoom Scan (7x7x7)/Cube 0: Measurement grid: $dx=5\text{mm}$, $dy=5\text{mm}$, $dz=5\text{mm}$

Reference Value = 5.48 V/m

Peak SAR (extrapolated) = 0.159 W/kg

SAR(1 g) = 0.065 mW/g; SAR(10 g) = 0.033 mW/g

Maximum value of SAR (measured) = 0.070 mW/g

Mid Channel 4/Zoom Scan (7x7x7)/Cube 1: Measurement grid: $dx=5\text{mm}$, $dy=5\text{mm}$, $dz=5\text{mm}$

Reference Value = 5.48 V/m

Peak SAR (extrapolated) = 0.113 W/kg

SAR(1 g) = 0.052 mW/g; SAR(10 g) = 0.028 mW/g

Maximum value of SAR (measured) = 0.054 mW/g

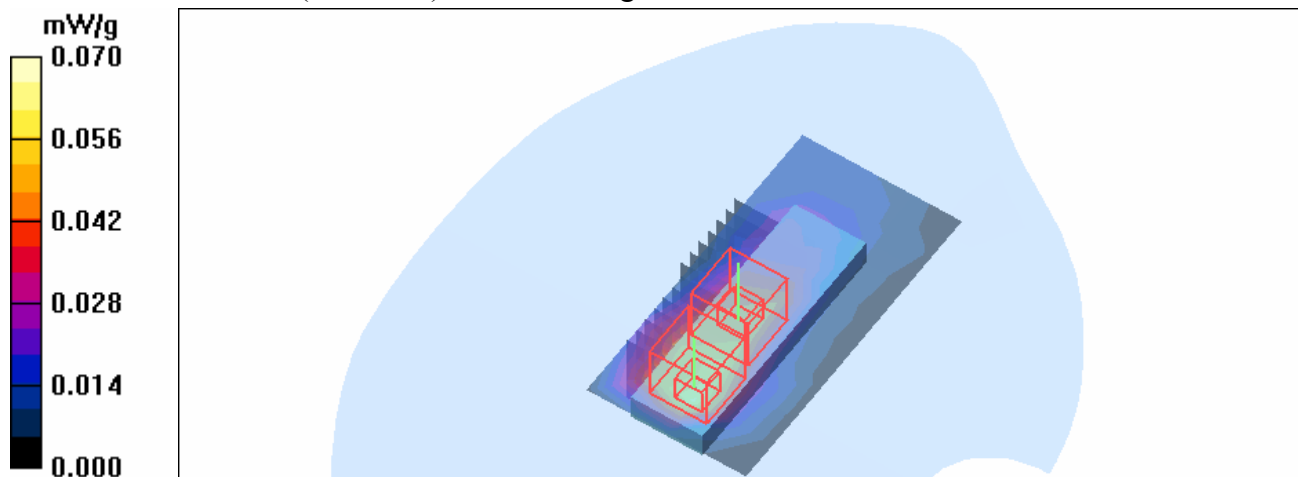

Test Laboratory: Advance Data Technology

N800C-11n span 40MHz-CH 7-M04

DUT: 802.11n/g/b Wireless USB Compact Adapter ; Type: WUB-370L ; Test Frequency: 2452 MHz

Communication System: 2.4G 11n span40 ; Frequency: 2452 MHz ; Duty Cycle: 1:1 ; Modulation type: BPSK

Medium: MSL2450 Medium parameters used: $f = 2452$ MHz; $\sigma = 1.92$ mho/m; $\epsilon_r = 52.8$; $\rho = 1000$ kg/m³ ; Liquid level : 152 mm

Phantom section: Flat Section ; Separation distance : 10 mm (The bottom side of the EUT to the Phantom)

Antenna type : Printed Antenna ; Air temp. : 23.5 degrees ; Liquid temp. : 22.3 degrees

DASY4 Configuration:

- Probe: ET3DV6 - SN1790 ; ConvF(4.35, 4.35, 4.35) ; Calibrated: 2006/11/23
- Sensor-Surface: 4mm (Mechanical Surface Detection)
- Electronics: DAE3 Sn510 ; Calibrated: 2006/9/7
- Phantom: SAM 12 ; Type: SAM V4.0 ; Serial: TP 1202
- Measurement SW: DASY4, V4.7 Build 53 ; Postprocessing SW: SEMCAD, V1.8 Build 172

High Channel 7/Area Scan (5x9x1): Measurement grid: dx=15mm, dy=15mm

Maximum value of SAR (measured) = 0.038 mW/g

High Channel 7/Zoom Scan (7x7x7)/Cube 0: Measurement grid: dx=5mm, dy=5mm, dz=5mm

Reference Value = 4.22 V/m

Peak SAR (extrapolated) = 0.099 W/kg

SAR(1 g) = 0.041 mW/g; SAR(10 g) = 0.021 mW/g

Maximum value of SAR (measured) = 0.044 mW/g

High Channel 7/Zoom Scan (7x7x7)/Cube 1: Measurement grid: dx=5mm, dy=5mm, dz=5mm

Reference Value = 4.22 V/m

Peak SAR (extrapolated) = 0.076 W/kg

SAR(1 g) = 0.033 mW/g; SAR(10 g) = 0.018 mW/g

Maximum value of SAR (measured) = 0.035 mW/g

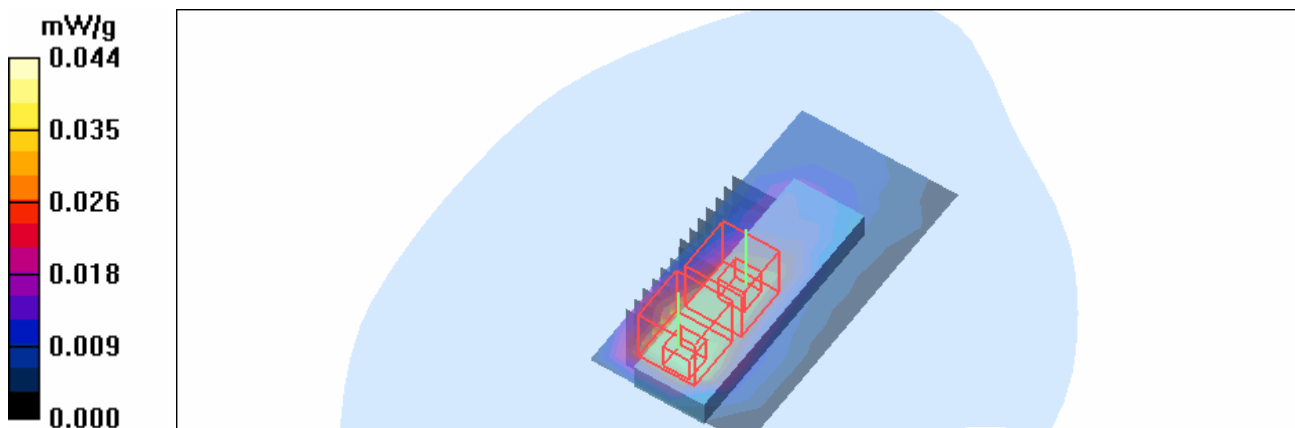

Test Laboratory: Advance Data Technology

C600-11b-CH 1-M05

DUT: 802.11n/g/b Wireless USB Compact Adapter ; Type: WUB-370L ; Test Frequency: 2412 MHz
Communication System: 802.11b ; Frequency: 2412 MHz ; Duty Cycle: 1:1 ; Modulation type: DBPSK
Medium: MSL2450 Medium parameters used: $f = 2412$ MHz; $\sigma = 1.87$ mho/m; $\epsilon_r = 53$; $\rho = 1000$ kg/m³ ; Liquid level : 152 mm
Phantom section: Flat Section ; Separation distance : 11 mm (The lateral side of the EUT to the Phantom)
Antenna type : Printed Antenna ; Air temp. : 23.5 degrees ; Liquid temp. : 22.3 degrees

DASY4 Configuration:

- Probe: ET3DV6 - SN1790 ; ConvF(4.35, 4.35, 4.35) ; Calibrated: 2006/11/23
- Sensor-Surface: 4mm (Mechanical Surface Detection)
- Electronics: DAE3 Sn510 ; Calibrated: 2006/9/7
- Phantom: SAM 12 ; Type: SAM V4.0 ; Serial: TP 1202
- Measurement SW: DASY4, V4.7 Build 53 ; Postprocessing SW: SEMCAD, V1.8 Build 172

Low Channel 1/Area Scan (5x9x1): Measurement grid: dx=15mm, dy=15mm
Maximum value of SAR (measured) = 0.271 mW/g

Low Channel 1/Zoom Scan (7x7x7)/Cube 0: Measurement grid: dx=5mm, dy=5mm, dz=5mm
Reference Value = 11.1 V/m
Peak SAR (extrapolated) = 0.593 W/kg
SAR(1 g) = 0.257 mW/g; SAR(10 g) = 0.128 mW/g
Maximum value of SAR (measured) = 0.277 mW/g

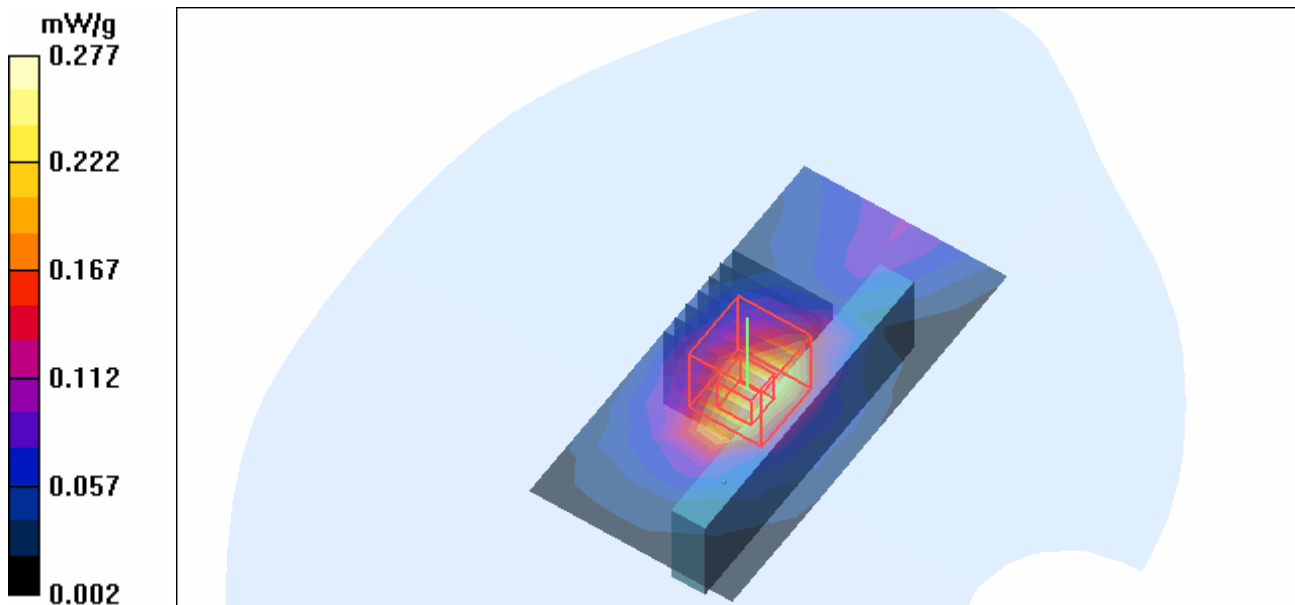

Test Laboratory: Advance Data Technology

C600-11b-CH 6-M05

DUT: 802.11n/g/b Wireless USB Compact Adapter ; Type: WUB-370L ; Test Frequency: 2437 MHz
Communication System: 802.11b ; Frequency: 2437 MHz ; Duty Cycle: 1:1 ; Modulation type: DBPSK
Medium: MSL2450 Medium parameters used: $f = 2437$ MHz; $\sigma = 1.9$ mho/m; $\epsilon_r = 52.9$; $\rho = 1000$ kg/m³ ; Liquid level : 152 mm
Phantom section: Flat Section ; Separation distance : 11 mm (The lateral side of the EUT to the Phantom)
Antenna type : Printed Antenna ; Air temp. : 23.5 degrees ; Liquid temp. : 22.3 degrees

DASY4 Configuration:

- Probe: ET3DV6 - SN1790 ; ConvF(4.35, 4.35, 4.35) ; Calibrated: 2006/11/23
- Sensor-Surface: 4mm (Mechanical Surface Detection)
- Electronics: DAE3 Sn510 ; Calibrated: 2006/9/7
- Phantom: SAM 12 ; Type: SAM V4.0 ; Serial: TP 1202
- Measurement SW: DASY4, V4.7 Build 53 ; Postprocessing SW: SEMCAD, V1.8 Build 172

Mid Channel 6/Area Scan (5x9x1): Measurement grid: dx=15mm, dy=15mm
Maximum value of SAR (measured) = 0.252 mW/g

Mid Channel 6/Zoom Scan (7x7x7)/Cube 0: Measurement grid: dx=5mm, dy=5mm, dz=5mm
Reference Value = 10.2 V/m
Peak SAR (extrapolated) = 0.606 W/kg
SAR(1 g) = 0.256 mW/g; SAR(10 g) = 0.126 mW/g
Maximum value of SAR (measured) = 0.280 mW/g

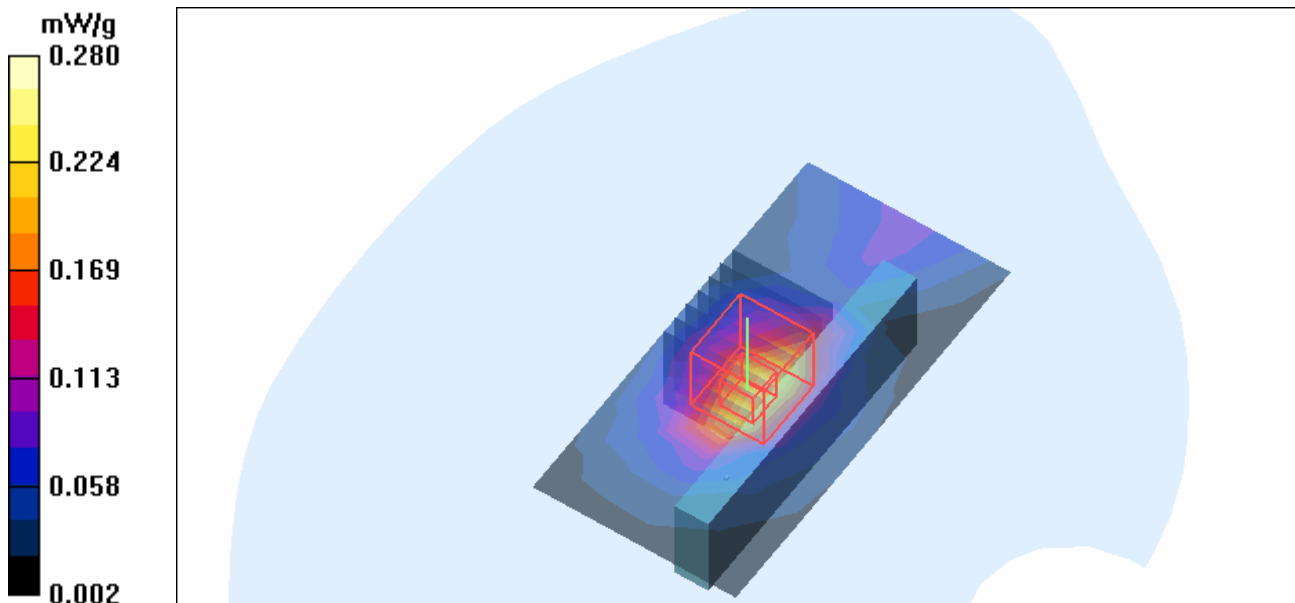

Test Laboratory: Advance Data Technology

C600-11b-CH 11-M05

DUT: 802.11n/g/b Wireless USB Compact Adapter ; Type: WUB-370L ; Test Frequency: 2462 MHz
Communication System: 802.11b ; Frequency: 2462 MHz ; Duty Cycle: 1:1 ; Modulation type: DBPSK
Medium: MSL2450 Medium parameters used: $f = 2462$ MHz; $\sigma = 1.93$ mho/m; $\epsilon_r = 52.7$; $\rho = 1000$ kg/m³ ; Liquid level : 152 mm
Phantom section: Flat Section ; Separation distance : 11 mm (The lateral side of the EUT to the Phantom)
Antenna type : Printed Antenna ; Air temp. : 23.5 degrees ; Liquid temp. : 22.3 degrees

DASY4 Configuration:

- Probe: ET3DV6 - SN1790 ; ConvF(4.35, 4.35, 4.35) ; Calibrated: 2006/11/23
- Sensor-Surface: 4mm (Mechanical Surface Detection)
- Electronics: DAE3 Sn510 ; Calibrated: 2006/9/7
- Phantom: SAM 12 ; Type: SAM V4.0 ; Serial: TP 1202
- Measurement SW: DASY4, V4.7 Build 53 ; Postprocessing SW: SEMCAD, V1.8 Build 172

High Channel 11/Area Scan (5x9x1): Measurement grid: dx=15mm, dy=15mm
Maximum value of SAR (measured) = 0.231 mW/g

High Channel 11/Zoom Scan (7x7x7)/Cube 0: Measurement grid: dx=5mm, dy=5mm, dz=5mm
Reference Value = 9.65 V/m
Peak SAR (extrapolated) = 0.549 W/kg
SAR(1 g) = 0.233 mW/g; SAR(10 g) = 0.114 mW/g
Maximum value of SAR (measured) = 0.251 mW/g

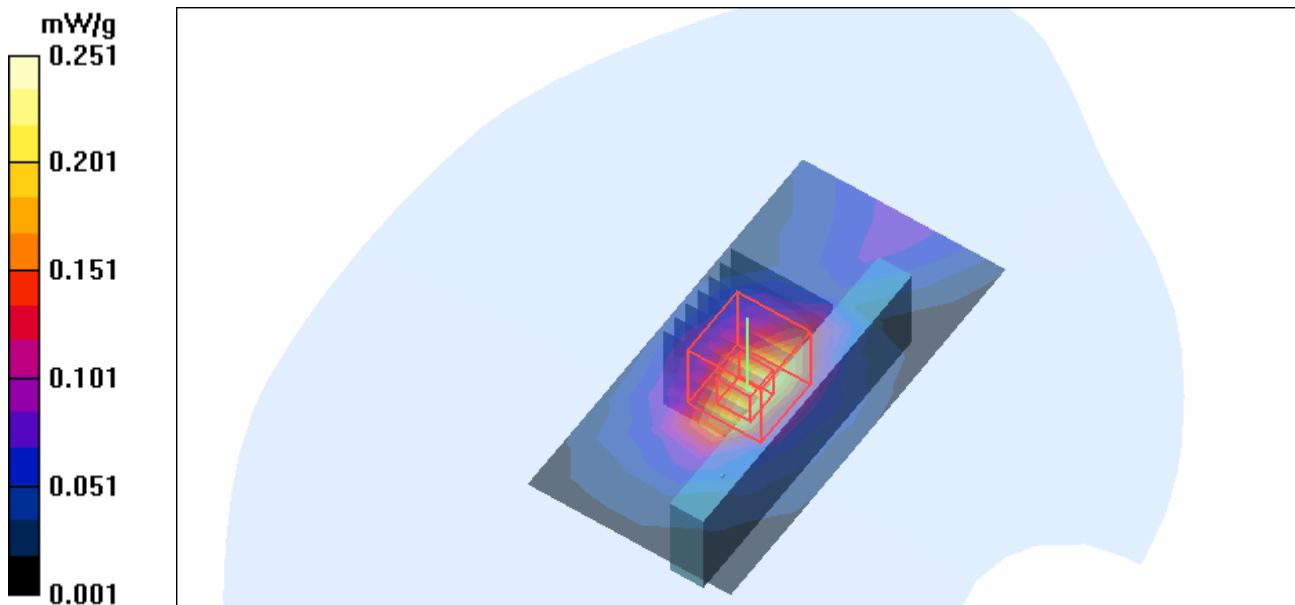

Test Laboratory: Advance Data Technology

C600-11g-CH 1-M06

DUT: 802.11n/g/b Wireless USB Compact Adapter ; Type: WUB-370L ; Test Frequency: 2412 MHz

Communication System: 802.11g ; Frequency: 2412 MHz ; Duty Cycle: 1:1 ; Modulation type: BPSK

Medium: MSL2450 Medium parameters used: $f = 2412$ MHz; $\sigma = 1.87$ mho/m; $\epsilon_r = 53$; $\rho = 1000$

kg/m³ ; Liquid level : 152 mm

Phantom section: Flat Section ; Separation distance : 11 mm (The lateral side of the EUT to the Phantom)

Antenna type : Printed Antenna ; Air temp. : 23.5 degrees ; Liquid temp. : 22.3 degrees

DASY4 Configuration:

- Probe: ET3DV6 - SN1790 ; ConvF(4.35, 4.35, 4.35) ; Calibrated: 2006/11/23

- Sensor-Surface: 4mm (Mechanical Surface Detection)

- Electronics: DAE3 Sn510 ; Calibrated: 2006/9/7

- Phantom: SAM 12 ; Type: SAM V4.0 ; Serial: TP 1202

- Measurement SW: DASY4, V4.7 Build 53 ; Postprocessing SW: SEMCAD, V1.8 Build 172

Low Channel 1/Area Scan (5x9x1): Measurement grid: dx=15mm, dy=15mm

Maximum value of SAR (measured) = 0.070 mW/g

Low Channel 1/Zoom Scan (7x7x7)/Cube 0: Measurement grid: dx=5mm, dy=5mm, dz=5mm

Reference Value = 5.29 V/m

Peak SAR (extrapolated) = 0.161 W/kg

SAR(1 g) = 0.071 mW/g; SAR(10 g) = 0.035 mW/g

Maximum value of SAR (measured) = 0.077 mW/g

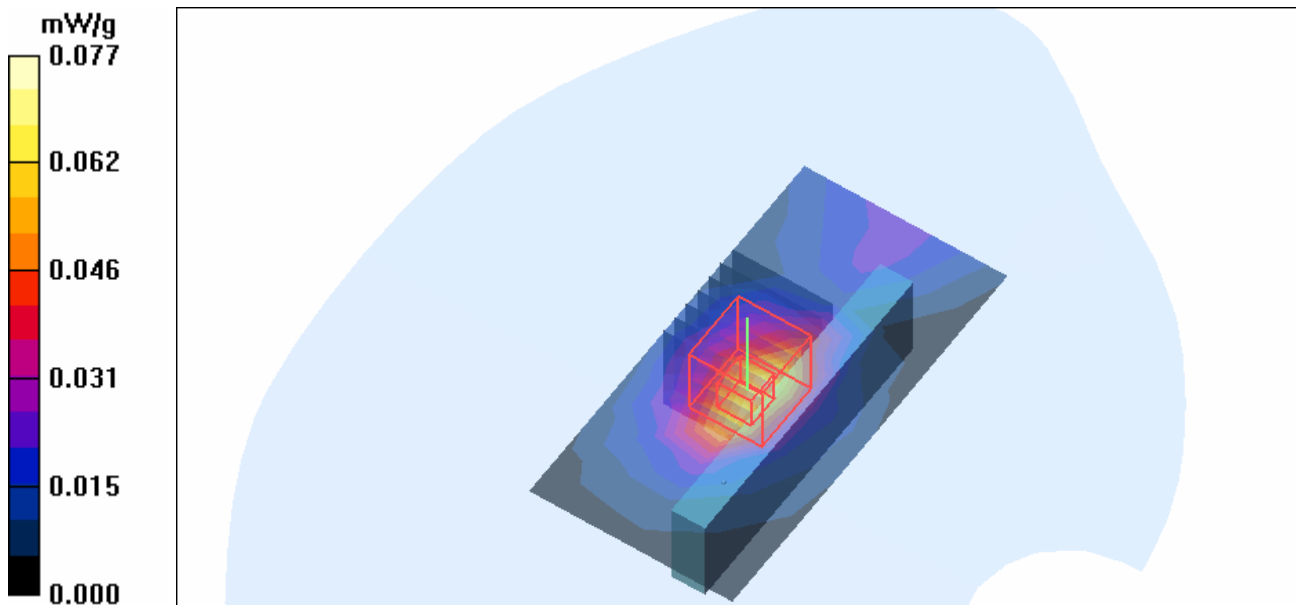

Test Laboratory: Advance Data Technology

C600-11g-CH 6-M06**DUT: 802.11n/g/b Wireless USB Compact Adapter ; Type: WUB-370L ; Test Frequency: 2437 MHz**

Communication System: 802.11g ; Frequency: 2437 MHz ; Duty Cycle: 1:1 ; Modulation type: BPSK

Medium: MSL2450 Medium parameters used: $f = 2437$ MHz; $\sigma = 1.9$ mho/m; $\epsilon_r = 52.9$; $\rho = 1000$ kg/m³ ; Liquid level : 152 mm

Phantom section: Flat Section ; Separation distance : 11 mm (The lateral side of the EUT to the Phantom)

Antenna type : Printed Antenna ; Air temp. : 23.5 degrees ; Liquid temp. : 22.3 degrees

DASY4 Configuration:

- Probe: ET3DV6 - SN1790 ; ConvF(4.35, 4.35, 4.35) ; Calibrated: 2006/11/23
- Sensor-Surface: 4mm (Mechanical Surface Detection)
- Electronics: DAE3 Sn510 ; Calibrated: 2006/9/7
- Phantom: SAM 12 ; Type: SAM V4.0 ; Serial: TP 1202
- Measurement SW: DASY4, V4.7 Build 53 ; Postprocessing SW: SEMCAD, V1.8 Build 172

Mid Channel 6/Area Scan (5x9x1): Measurement grid: dx=15mm, dy=15mm

Maximum value of SAR (measured) = 0.074 mW/g

Mid Channel 6/Zoom Scan (7x7x7)/Cube 0: Measurement grid: dx=5mm, dy=5mm, dz=5mm

Reference Value = 5.53 V/m

Peak SAR (extrapolated) = 0.177 W/kg

SAR(1 g) = 0.074 mW/g; SAR(10 g) = 0.037 mW/g

Maximum value of SAR (measured) = 0.080 mW/g

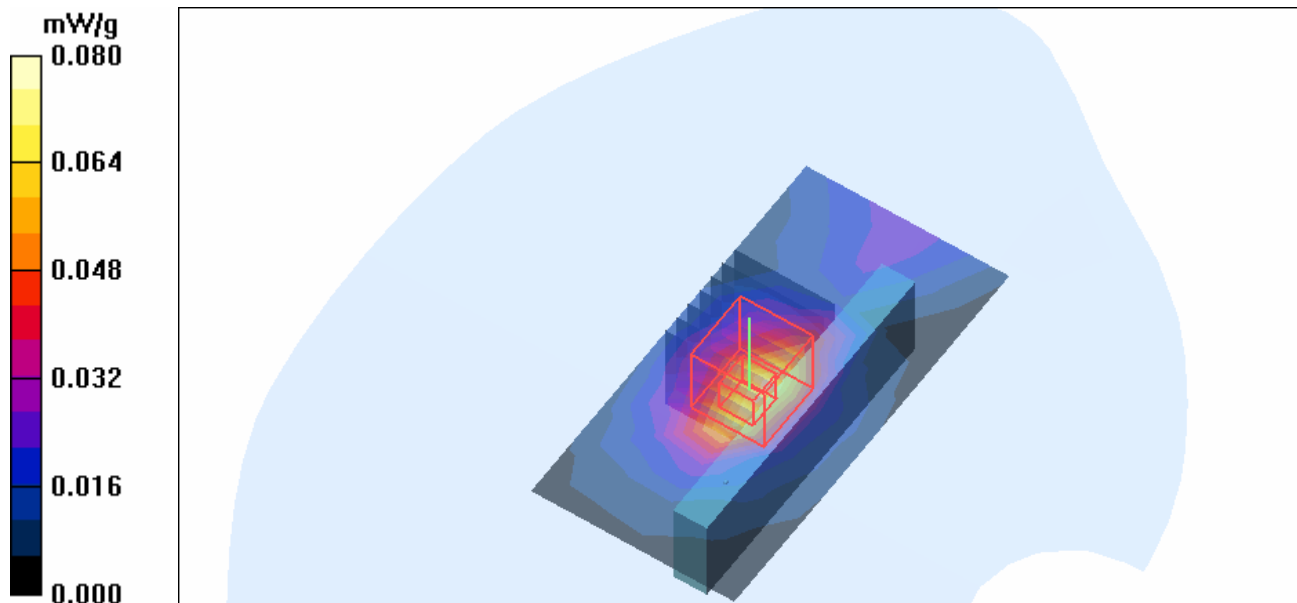

Test Laboratory: Advance Data Technology

C600-11g-CH 11-M06

DUT: 802.11n/g/b Wireless USB Compact Adapter ; Type: WUB-370L ; Test Frequency: 2462 MHz
Communication System: 802.11g ; Frequency: 2462 MHz ; Duty Cycle: 1:1 ; Modulation type: BPSK
Medium: MSL2450 Medium parameters used: $f = 2462$ MHz; $\sigma = 1.93$ mho/m; $\epsilon_r = 52.7$; $\rho = 1000$ kg/m³ ; Liquid level : 152 mm
Phantom section: Flat Section ; Separation distance : 11 mm (The lateral side of the EUT to the Phantom)
Antenna type : Printed Antenna ; Air temp. : 23.5 degrees ; Liquid temp. : 22.3 degrees

DASY4 Configuration:

- Probe: ET3DV6 - SN1790 ; ConvF(4.35, 4.35, 4.35) ; Calibrated: 2006/11/23
- Sensor-Surface: 4mm (Mechanical Surface Detection)
- Electronics: DAE3 Sn510 ; Calibrated: 2006/9/7
- Phantom: SAM 12 ; Type: SAM V4.0 ; Serial: TP 1202
- Measurement SW: DASY4, V4.7 Build 53 ; Postprocessing SW: SEMCAD, V1.8 Build 172

High Channel 11/Area Scan (5x9x1): Measurement grid: dx=15mm, dy=15mm
Maximum value of SAR (measured) = 0.062 mW/g

High Channel 11/Zoom Scan (7x7x7)/Cube 0: Measurement grid: dx=5mm, dy=5mm, dz=5mm
Reference Value = 4.96 V/m
Peak SAR (extrapolated) = 0.144 W/kg
SAR(1 g) = 0.063 mW/g; SAR(10 g) = 0.031 mW/g
Maximum value of SAR (measured) = 0.068 mW/g

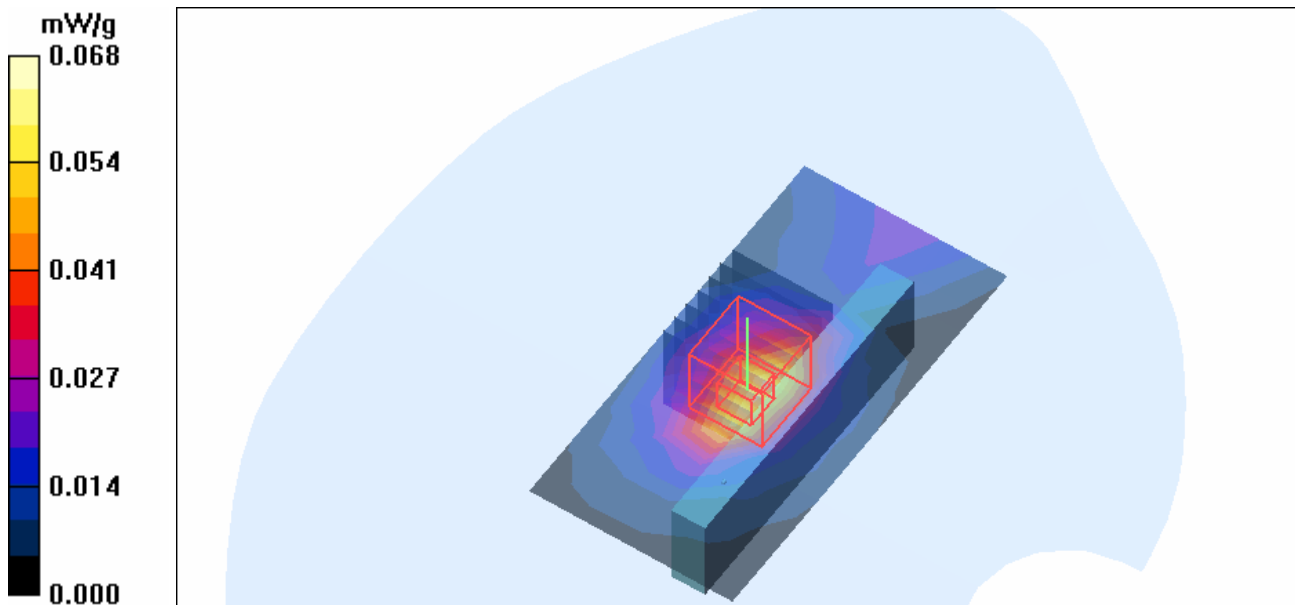

Test Laboratory: Advance Data Technology

C600-11n span 20MHz-CH 1-M07

DUT: 802.11n/g/b Wireless USB Compact Adapter ; Type: WUB-370L ; Test Frequency: 2412 MHz

Communication System: 2.4G 11n span20 ; Frequency: 2412 MHz ; Duty Cycle: 1:1 ; Modulation type: BPSK

Medium: MSL2450 Medium parameters used: $f = 2412$ MHz; $\sigma = 1.87$ mho/m; $\epsilon_r = 53$; $\rho = 1000$ kg/m³ ; Liquid level : 152 mm

Phantom section: Flat Section ; Separation distance : 11 mm (The lateral side of the EUT to the Phantom)

Antenna type : Printed Antenna ; Air temp. : 23.5 degrees ; Liquid temp. : 22.3 degrees

DASY4 Configuration:

- Probe: ET3DV6 - SN1790 ; ConvF(4.35, 4.35, 4.35) ; Calibrated: 2006/11/23
- Sensor-Surface: 4mm (Mechanical Surface Detection)
- Electronics: DAE3 Sn510 ; Calibrated: 2006/9/7
- Phantom: SAM 12 ; Type: SAM V4.0 ; Serial: TP 1202
- Measurement SW: DASY4, V4.7 Build 53 ; Postprocessing SW: SEMCAD, V1.8 Build 172

Low Channel 1/Area Scan (5x9x1): Measurement grid: dx=15mm, dy=15mm

Maximum value of SAR (measured) = 0.070 mW/g

Low Channel 1/Zoom Scan (7x7x7)/Cube 0: Measurement grid: dx=5mm, dy=5mm, dz=5mm

Reference Value = 5.33 V/m

Peak SAR (extrapolated) = 0.156 W/kg

SAR(1 g) = 0.069 mW/g; SAR(10 g) = 0.035 mW/g

Maximum value of SAR (measured) = 0.075 mW/g

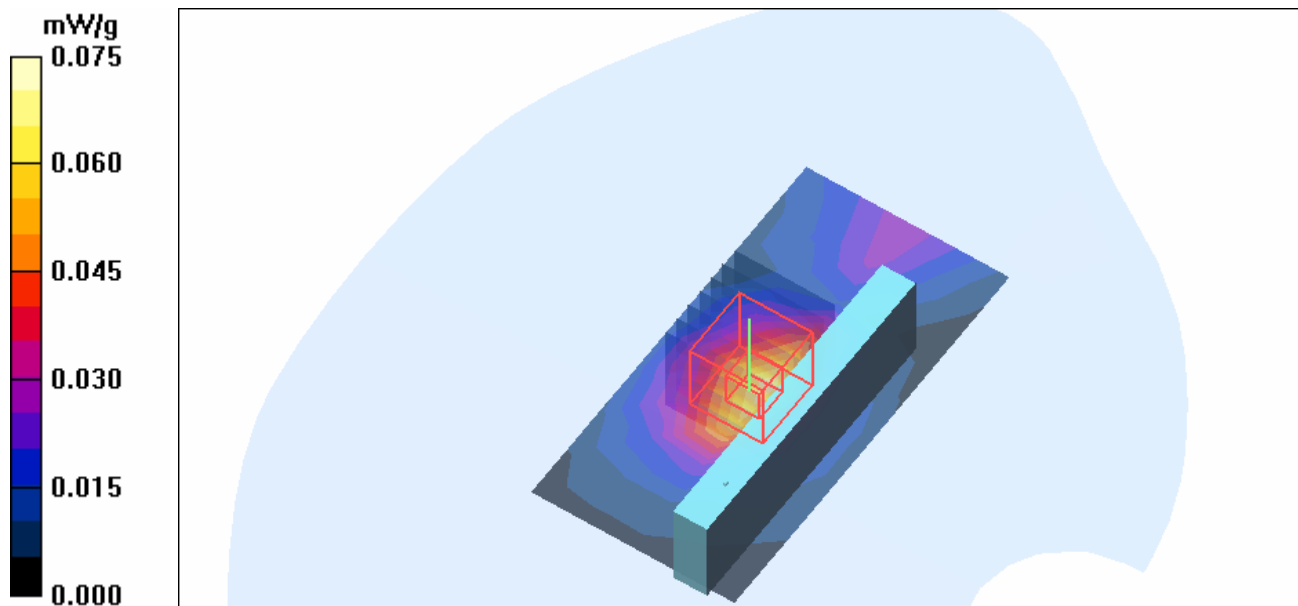

Test Laboratory: Advance Data Technology

C600-11n span 20MHz-CH 6-M07

DUT: 802.11n/g/b Wireless USB Compact Adapter ; Type: WUB-370L ; Test Frequency: 2437 MHz

Communication System: 2.4G 11n span20 ; Frequency: 2437 MHz ; Duty Cycle: 1:1 ; Modulation type: BPSK

Medium: MSL2450 Medium parameters used: $f = 2437$ MHz; $\sigma = 1.9$ mho/m; $\epsilon_r = 52.9$; $\rho = 1000$ kg/m³ ; Liquid level : 152 mm

Phantom section: Flat Section ; Separation distance : 11 mm (The lateral side of the EUT to the Phantom)

Antenna type : Printed Antenna ; Air temp. : 23.5 degrees ; Liquid temp. : 22.3 degrees

DASY4 Configuration:

- Probe: ET3DV6 - SN1790 ; ConvF(4.35, 4.35, 4.35) ; Calibrated: 2006/11/23
- Sensor-Surface: 4mm (Mechanical Surface Detection)
- Electronics: DAE3 Sn510 ; Calibrated: 2006/9/7
- Phantom: SAM 12 ; Type: SAM V4.0 ; Serial: TP 1202
- Measurement SW: DASY4, V4.7 Build 53 ; Postprocessing SW: SEMCAD, V1.8 Build 172

Mid Channel 6/Area Scan (5x9x1): Measurement grid: dx=15mm, dy=15mm

Maximum value of SAR (measured) = 0.068 mW/g

Mid Channel 6/Zoom Scan (7x7x7)/Cube 0: Measurement grid: dx=5mm, dy=5mm, dz=5mm

Reference Value = 5.03 V/m

Peak SAR (extrapolated) = 0.160 W/kg

SAR(1 g) = 0.068 mW/g; SAR(10 g) = 0.034 mW/g

Maximum value of SAR (measured) = 0.073 mW/g

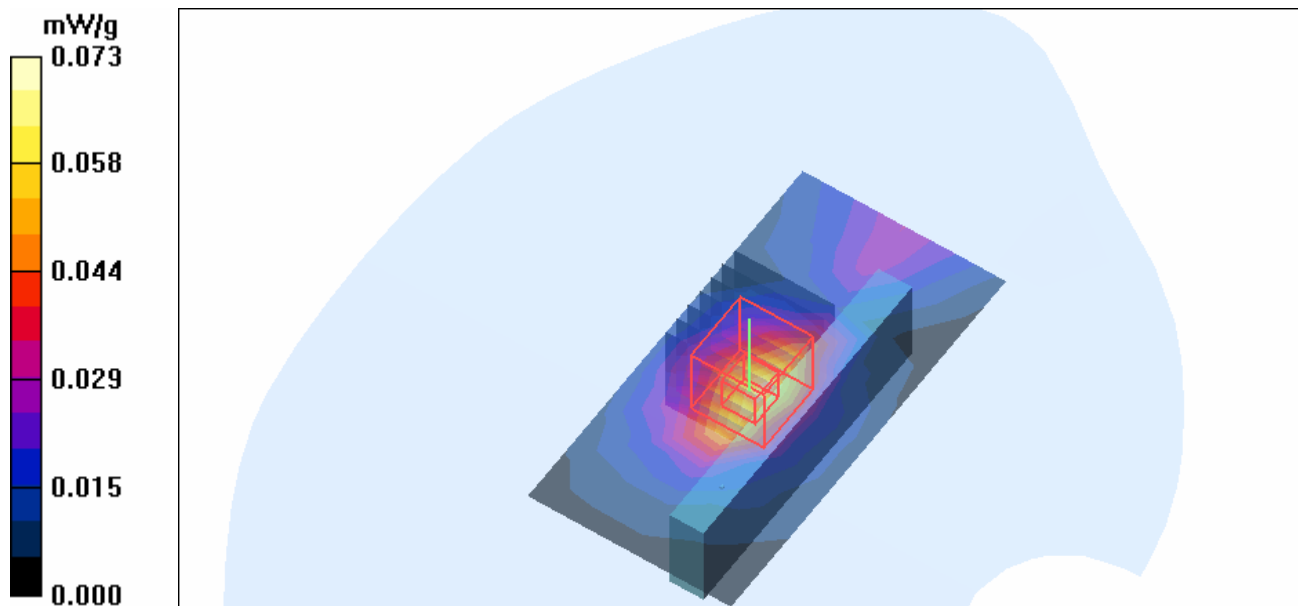

Test Laboratory: Advance Data Technology

C600-11n span 20MHz-CH 11-M07

DUT: 802.11n/g/b Wireless USB Compact Adapter ; Type: WUB-370L ; Test Frequency: 2462 MHz

Communication System: 2.4G 11n span20 ; Frequency: 2462 MHz ; Duty Cycle: 1:1 ; Modulation type: BPSK

Medium: MSL2450 Medium parameters used: $f = 2462$ MHz; $\sigma = 1.93$ mho/m; $\epsilon_r = 52.7$; $\rho = 1000$ kg/m³ ; Liquid level : 152 mm

Phantom section: Flat Section ; Separation distance : 11 mm (The lateral side of the EUT to the Phantom)

Antenna type : Printed Antenna ; Air temp. : 23.5 degrees ; Liquid temp. : 22.3 degrees

DASY4 Configuration:

- Probe: ET3DV6 - SN1790 ; ConvF(4.35, 4.35, 4.35) ; Calibrated: 2006/11/23
- Sensor-Surface: 4mm (Mechanical Surface Detection)
- Electronics: DAE3 Sn510 ; Calibrated: 2006/9/7
- Phantom: SAM 12 ; Type: SAM V4.0 ; Serial: TP 1202
- Measurement SW: DASY4, V4.7 Build 53 ; Postprocessing SW: SEMCAD, V1.8 Build 172

High Channel 11/Area Scan (5x9x1): Measurement grid: dx=15mm, dy=15mm

Maximum value of SAR (measured) = 0.074 mW/g

High Channel 11/Zoom Scan (7x7x7)/Cube 0: Measurement grid: dx=5mm, dy=5mm, dz=5mm

Reference Value = 5.10 V/m

Peak SAR (extrapolated) = 0.163 W/kg

SAR(1 g) = 0.073 mW/g; SAR(10 g) = 0.037 mW/g

Maximum value of SAR (measured) = 0.078 mW/g

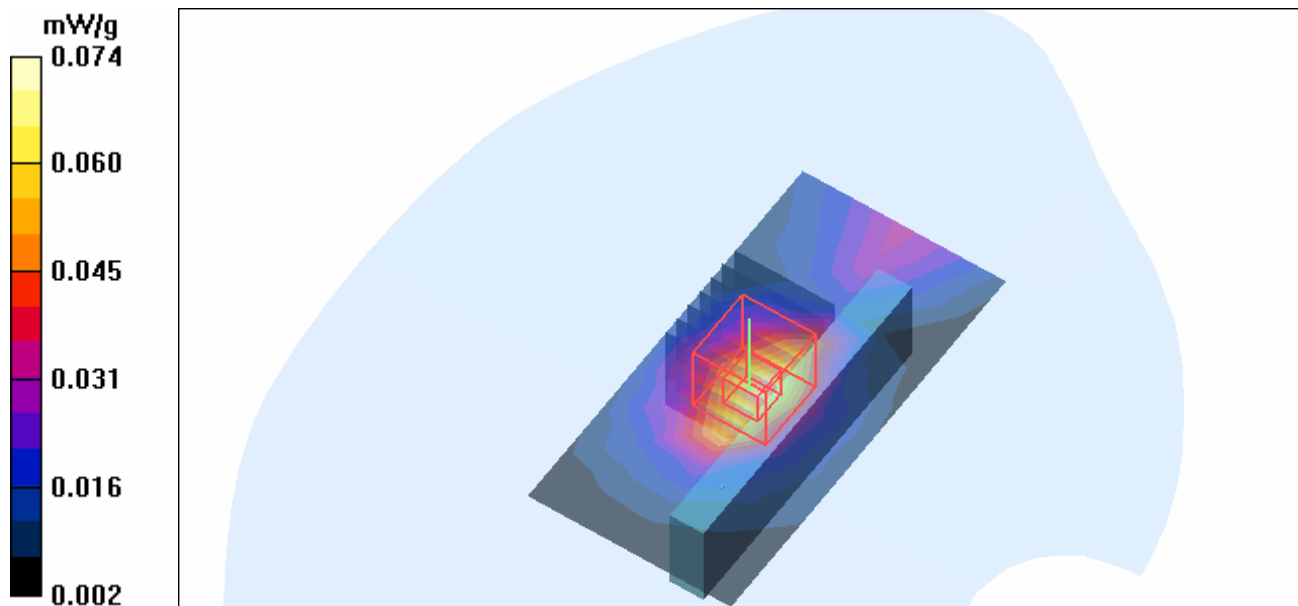

Test Laboratory: Advance Data Technology

C600-11n span 40MHz-CH 1-M08

DUT: 802.11n/g/b Wireless USB Compact Adapter ; Type: WUB-370L ; Test Frequency: 2422 MHz

Communication System: 802.11n 40MHz ; Frequency: 2422 MHz ; Duty Cycle: 1:1 ; Modulation type: BPSK

Medium: MSL2450 Medium parameters used: $f = 2422$ MHz; $\sigma = 1.88$ mho/m; $\epsilon_r = 52.9$; $\rho = 1000$ kg/m³ ; Liquid level : 152 mm

Phantom section: Flat Section ; Separation distance : 11 mm (The lateral side of the EUT to the Phantom)

Antenna type : Printed Antenna ; Air temp. : 23.5 degrees ; Liquid temp. : 22.3 degrees

DASY4 Configuration:

- Probe: ET3DV6 - SN1790 ; ConvF(4.35, 4.35, 4.35) ; Calibrated: 2006/11/23
- Sensor-Surface: 4mm (Mechanical Surface Detection)
- Electronics: DAE3 Sn510 ; Calibrated: 2006/9/7
- Phantom: SAM 12 ; Type: SAM V4.0 ; Serial: TP 1202
- Measurement SW: DASY4, V4.7 Build 53 ; Postprocessing SW: SEMCAD, V1.8 Build 172

Low Channel 1/Area Scan (5x9x1): Measurement grid: dx=15mm, dy=15mm

Maximum value of SAR (measured) = 0.026 mW/g

Low Channel 1/Zoom Scan (7x7x7)/Cube 0: Measurement grid: dx=5mm, dy=5mm, dz=5mm

Reference Value = 3.78 V/m

Peak SAR (extrapolated) = 0.052 W/kg

SAR(1 g) = 0.026 mW/g; SAR(10 g) = 0.014 mW/g

Maximum value of SAR (measured) = 0.027 mW/g

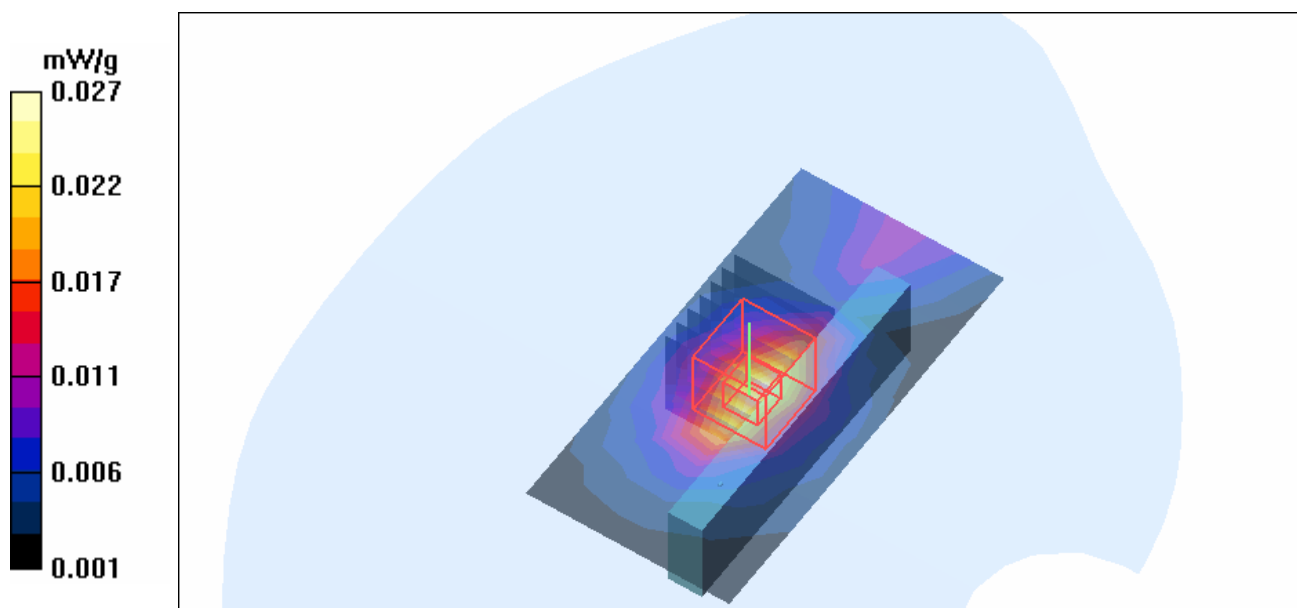

Test Laboratory: Advance Data Technology

C600-11n span 40MHz-CH 4-M08

DUT: 802.11n/g/b Wireless USB Compact Adapter ; Type: WUB-370L ; Test Frequency: 2437 MHz

Communication System: 802.11n 40MHz ; Frequency: 2437 MHz ; Duty Cycle: 1:1 ; Modulation type: BPSK

Medium: MSL2450 Medium parameters used: $f = 2437 \text{ MHz}$; $\sigma = 1.9 \text{ mho/m}$; $\epsilon_r = 52.9$; $\rho = 1000 \text{ kg/m}^3$; Liquid level : 152 mm

Phantom section: Flat Section ; Separation distance : 11 mm (The lateral side of the EUT to the Phantom)

Antenna type : Printed Antenna ; Air temp. : 23.5 degrees ; Liquid temp. : 22.3 degrees

DASY4 Configuration:

- Probe: ET3DV6 - SN1790 ; ConvF(4.35, 4.35, 4.35) ; Calibrated: 2006/11/23
- Sensor-Surface: 4mm (Mechanical Surface Detection)
- Electronics: DAE3 Sn510 ; Calibrated: 2006/9/7
- Phantom: SAM 12 ; Type: SAM V4.0 ; Serial: TP 1202
- Measurement SW: DASY4, V4.7 Build 53 ; Postprocessing SW: SEMCAD, V1.8 Build 172

Mid Channel 4/Area Scan (5x9x1): Measurement grid: $dx=15\text{mm}$, $dy=15\text{mm}$

Maximum value of SAR (measured) = 0.038 mW/g

Mid Channel 4/Zoom Scan (7x7x7)/Cube 0: Measurement grid: $dx=5\text{mm}$, $dy=5\text{mm}$, $dz=5\text{mm}$

Reference Value = 4.31 V/m

Peak SAR (extrapolated) = 0.080 W/kg

SAR(1 g) = 0.039 mW/g; SAR(10 g) = 0.022 mW/g

Maximum value of SAR (measured) = 0.041 mW/g

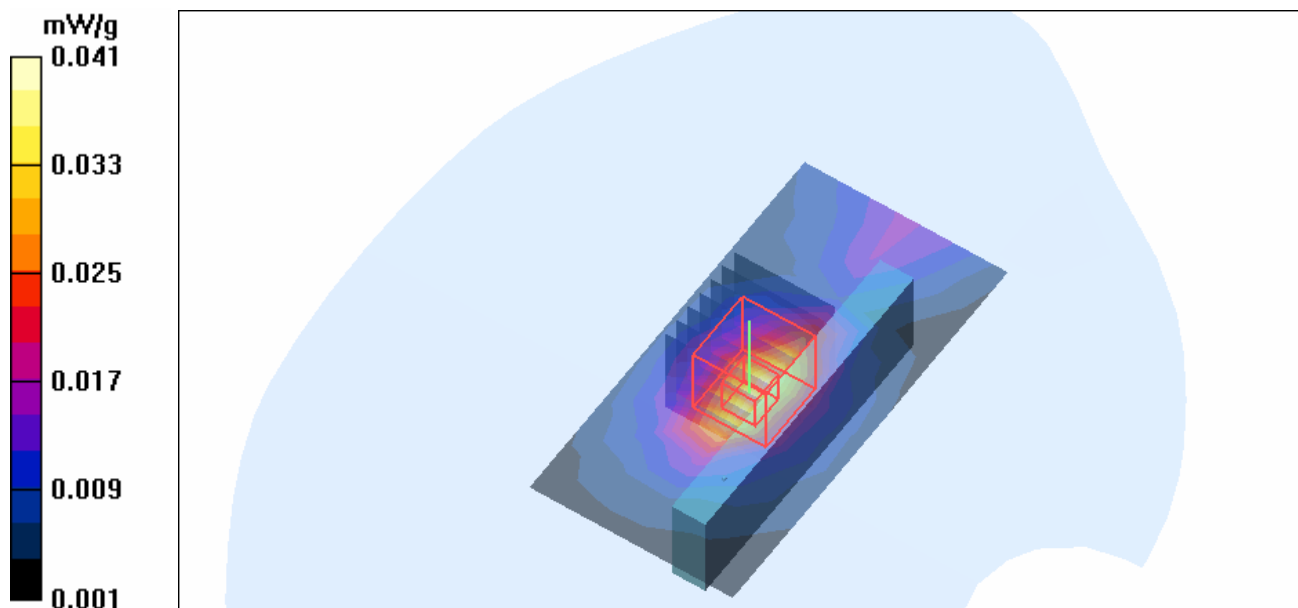

Test Laboratory: Advance Data Technology

C600-11n span 40MHz-CH 7-M08

DUT: 802.11n/g/b Wireless USB Compact Adapter ; Type: WUB-370L ; Test Frequency: 2452 MHz

Communication System: 802.11n 40MHz ; Frequency: 2452 MHz ; Duty Cycle: 1:1 ; Modulation type: BPSK

Medium: MSL2450 Medium parameters used: $f = 2452 \text{ MHz}$; $\sigma = 1.92 \text{ mho/m}$; $\epsilon_r = 52.8$; $\rho = 1000 \text{ kg/m}^3$; Liquid level : 152 mm

Phantom section: Flat Section ; Separation distance : 11 mm (The lateral side of the EUT to the Phantom)

Antenna type : Printed Antenna ; Air temp. : 23.5 degrees ; Liquid temp. : 22.3 degrees

DASY4 Configuration:

- Probe: ET3DV6 - SN1790 ; ConvF(4.35, 4.35, 4.35) ; Calibrated: 2006/11/23
- Sensor-Surface: 4mm (Mechanical Surface Detection)
- Electronics: DAE3 Sn510 ; Calibrated: 2006/9/7
- Phantom: SAM 12 ; Type: SAM V4.0 ; Serial: TP 1202
- Measurement SW: DASY4, V4.7 Build 53 ; Postprocessing SW: SEMCAD, V1.8 Build 172

High Channel 7/Area Scan (5x9x1): Measurement grid: $dx=15\text{mm}$, $dy=15\text{mm}$

Maximum value of SAR (measured) = 0.017 mW/g

High Channel 7/Zoom Scan (7x7x7)/Cube 0: Measurement grid: $dx=5\text{mm}$, $dy=5\text{mm}$, $dz=5\text{mm}$

Reference Value = 3.28 V/m;

Peak SAR (extrapolated) = 0.040 W/kg

SAR(1 g) = 0.019 mW/g; SAR(10 g) = 0.011 mW/g

Maximum value of SAR (measured) = 0.021 mW/g

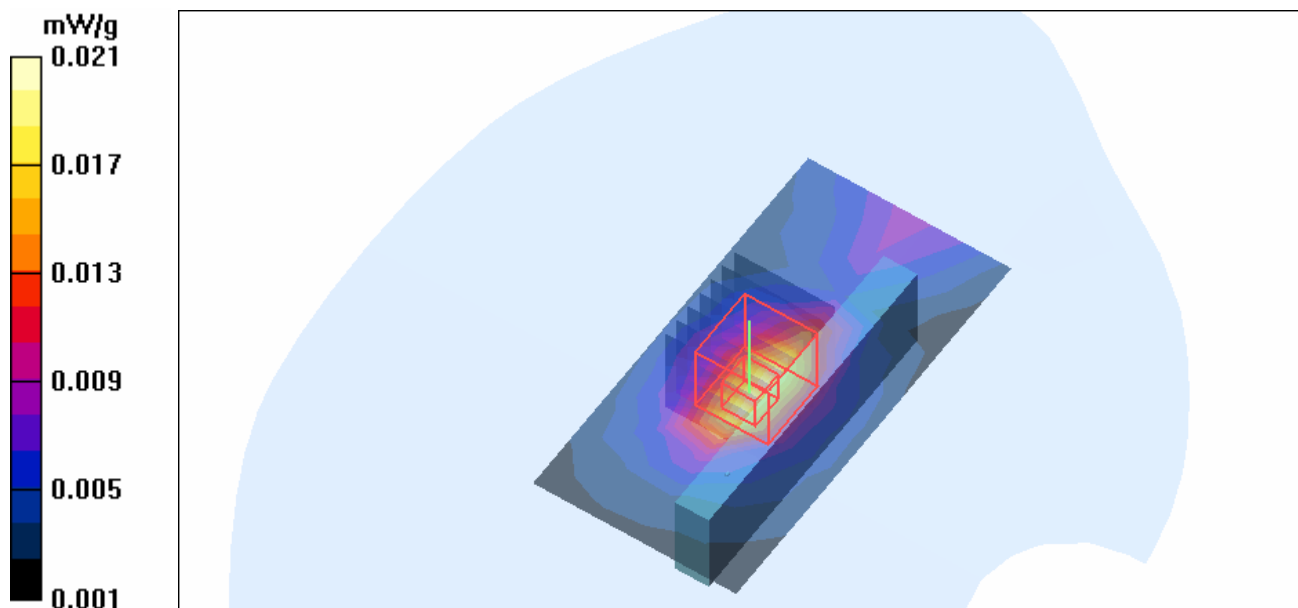

Test Laboratory: Advance Data Technology

System Validation Check-MSL 2450MHz**DUT: Dipole 2450 MHz ; Type: D2450V2 ; Serial: 716 ; Test Frequency: 2450 MHz**

Communication System: CW ; Frequency: 2450 MHz; Duty Cycle: 1:1; Modulation type: CW
Medium: MSL2450; Medium parameters used: $f = 2450$ MHz; $\sigma = 1.92$ mho/m; $\epsilon_r = 52.8$; $\rho = 1000$ kg/m³ ; Liquid level : 152 mm
Phantom section: Flat Section ; Separation distance : 10 mm (The feetpoint of the dipole to the Phantom) Air temp. : 23.5 degrees ; Liquid temp. : 22.3 degrees

DASY4 Configuration:

- Probe: ET3DV6 - SN1790 ; ConvF(4.35, 4.35, 4.35) ; Calibrated: 2006/11/23
- Sensor-Surface: 4mm (Mechanical Surface Detection)
- Electronics: DAE3 Sn510; Calibrated: 2006/9/7
- Phantom: SAM 12; Type: SAM V4.0; Serial: TP 1202
- Measurement SW: DASY4, V4.7 Build 53; Postprocessing SW: SEMCAD, V1.8 Build 172

d=10mm, Pin=250mW/Area Scan (5x7x1): Measurement grid: dx=15mm, dy=15mm
Maximum value of SAR (measured) = 14.7 mW/g

d=10mm, Pin=250mW/Zoom Scan (7x7x7)/Cube 0: Measurement grid: dx=5mm, dy=5mm, dz=5mm

Reference Value = 88.4 V/m; Power Drift = -0.122 dB

Peak SAR (extrapolated) = 31.2 W/kg

SAR(1 g) = 13.4 mW/g; SAR(10 g) = 6.1 mW/g

Maximum value of SAR (measured) = 14.6 mW/g

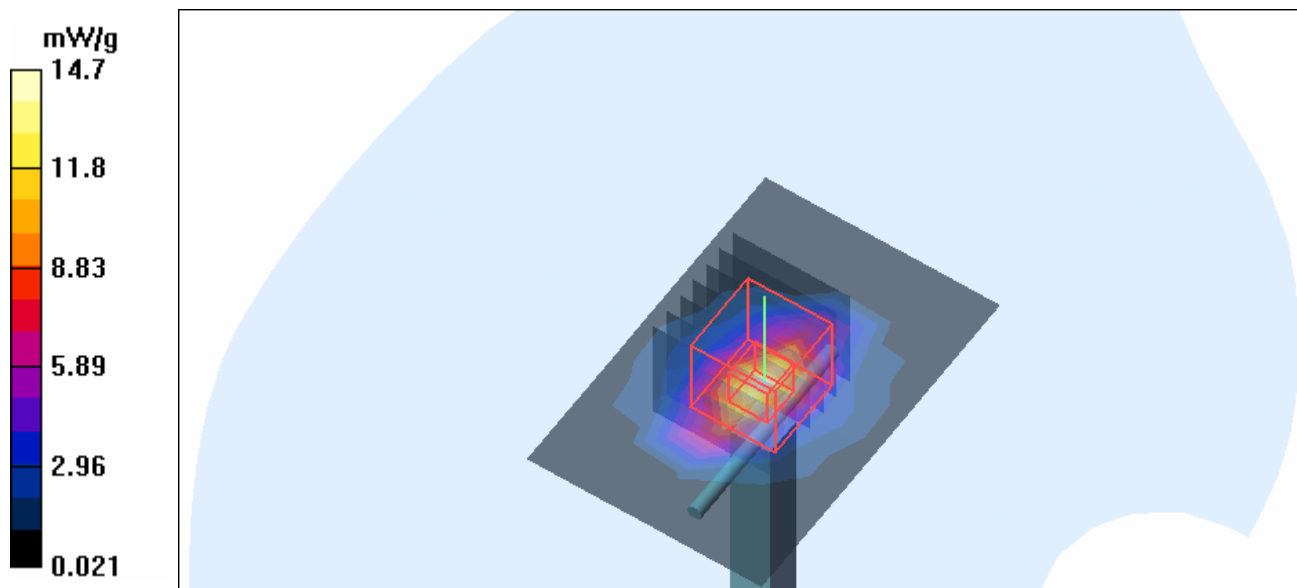

APPENDIX B: ADT SAR MEASUREMENT SYSTEM



APPENDIX C: PHOTOGRAPHS OF SYSTEM VALIDATION





APPENDIX D: SYSTEM CERTIFICATE & CALIBRATION

D1: SAM PHANTOM

Schmid & Partner Engineering AG

Zeughausstrasse 43, 8004 Zurich, Switzerland, Phone +41 1 245 97 00, Fax +41 1 245 97 79

Certificate of conformity / First Article Inspection

Item	SAM Twin Phantom V4.0
Type No	QD 000 P40 CA
Series No	TP-1150 and higher
Manufacturer / Origin	Untersee Composites Hauptstr. 69 CH-8559 Fruthwilen Switzerland

Tests

The series production process used allows the limitation to test of first articles. Complete tests were made on the pre-series Type No. QD 000 P40 AA, Serial No. TP-1001 and on the series first article Type No. QD 000 P40 BA, Serial No. TP-1006. Certain parameters have been retested using further series units (called samples).

Test	Requirement	Details	Units tested
Shape	Compliance with the geometry according to the CAD model.	IT'IS CAD File (*)	First article, Samples
Material thickness	Compliant with the requirements according to the standards	2mm +/- 0.2mm in specific areas	First article, Samples
Material parameters	Dielectric parameters for required frequencies	200 MHz – 3 GHz Relative permittivity < 5 Loss tangent < 0.05.	Material sample TP 104-5
Material resistivity	The material has been tested to be compatible with the liquids defined in the standards	Liquid type HSL 1800 and others according to the standard.	Pre-series, First article

Standards

- [1] CENELEC EN 50361
- [2] IEEE P1528-200x draft 6.5
- [3] IEC PT 62209 draft 0.9

(*) The IT'IS CAD file is derived from [2] and is also within the tolerance requirements of the shapes of [1] and [3].

Conformity

Based on the sample tests above, we certify that this item is in compliance with the uncertainty requirements of SAR measurements specified in standard [1] and draft standards [2] and [3].

Date 28.02.2002

Signature / Stamp

F. Bombault

**Schmid & Partner
Engineering AG**

Zeughausstrasse 43, CH-8004 Zurich
Tel. +41 1 245 97 00, Fax +41 1 245 97 79

Johannes Kofler



D2: DOSIMETRIC E-FIELD PROBE

**Calibration Laboratory of
Schmid & Partner
Engineering AG**
Zeughausstrasse 43, 8004 Zurich, Switzerland



S Schweizerischer Kalibrierdienst
S Service suisse d'étalonnage
C Servizio svizzero di taratura
S Swiss Calibration Service

Accredited by the Swiss Federal Office of Metrology and Accreditation
The Swiss Accreditation Service is one of the signatories to the EA
Multilateral Agreement for the recognition of calibration certificates

Accreditation No.: **SCS 108**

Client **ADT (Auden)**

Certificate No: **ET3-1790_Nov06**

CALIBRATION CERTIFICATE

Object **ET3DV6 - SN:1790**

Calibration procedure(s) **QA CAL-01 v5
Calibration procedure for dosimetric E-field probes**

Calibration date: **November 23, 2006**

Condition of the calibrated item **In Tolerance**

This calibration certificate documents the traceability to national standards, which realize the physical units of measurements (SI).
The measurements and the uncertainties with confidence probability are given on the following pages and are part of the certificate.

All calibrations have been conducted in the closed laboratory facility: environment temperature (22 ± 3)°C and humidity < 70%.

Calibration Equipment used (M&TE critical for calibration)

Primary Standards	ID #	Cal Date (Calibrated by, Certificate No.)	Scheduled Calibration
Power meter E4419B	GB41293874	5-Apr-06 (METAS, No. 251-00557)	Apr-07
Power sensor E4412A	MY41495277	5-Apr-06 (METAS, No. 251-00557)	Apr-07
Power sensor E4412A	MY41498087	5-Apr-06 (METAS, No. 251-00557)	Apr-07
Reference 3 dB Attenuator	SN: S5054 (3c)	10-Aug-06 (METAS, No. 217-00592)	Aug-07
Reference 20 dB Attenuator	SN: S5086 (20b)	4-Apr-06 (METAS, No. 251-00558)	Apr-07
Reference 30 dB Attenuator	SN: S5129 (30b)	10-Aug-06 (METAS, No. 217-00593)	Aug-07
Reference Probe ES3DV2	SN: 3013	2-Jan-06 (SPEAG, No. ES3-3013_Jan06)	Jan-07
DAE4	SN: 654	21-Jun-06 (SPEAG, No. DAE4-654_Jun06)	Jun-07
Secondary Standards	ID #	Check Date (in house)	Scheduled Check
RF generator HP 8648C	US3642U01700	4-Aug-99 (SPEAG, in house check Nov-05)	In house check: Nov-07
Network Analyzer HP 8753E	US37390585	18-Oct-01 (SPEAG, in house check Oct-06)	In house check: Oct-07

	Name	Function	Signature
Calibrated by:	Katja Pokovic	Technical Manager	
Approved by:	Niels Kuster	Quality Manager	

Issued: November 23, 2006

This calibration certificate shall not be reproduced except in full without written approval of the laboratory.



Accredited by the Swiss Federal Office of Metrology and Accreditation
The Swiss Accreditation Service is one of the signatories to the EA
Multilateral Agreement for the recognition of calibration certificates

Accreditation No.: **SCS 108**

Glossary:

TSL	tissue simulating liquid
NORM _{x,y,z}	sensitivity in free space
ConF	sensitivity in TSL / NORM _{x,y,z}
DCP	diode compression point
Polarization ϕ	ϕ rotation around probe axis
Polarization ϑ	ϑ rotation around an axis that is in the plane normal to probe axis (at measurement center), i.e., $\vartheta = 0$ is normal to probe axis

Calibration is Performed According to the Following Standards:

- IEEE Std 1528-2003, "IEEE Recommended Practice for Determining the Peak Spatial-Averaged Specific Absorption Rate (SAR) in the Human Head from Wireless Communications Devices: Measurement Techniques", December 2003
- CENELEC EN 50361, "Basic standard for the measurement of Specific Absorption Rate related to human exposure to electromagnetic fields from mobile phones (300 MHz - 3 GHz), July 2001

Methods Applied and Interpretation of Parameters:

- NORM_{x,y,z}**: Assessed for E-field polarization $\vartheta = 0$ ($f \leq 900$ MHz in TEM-cell; $f > 1800$ MHz: R22 waveguide). NORM_{x,y,z} are only intermediate values, i.e., the uncertainties of NORM_{x,y,z} does not effect the E²-field uncertainty inside TSL (see below *ConvF*).
- NORM(f)_{x,y,z}** = NORM_{x,y,z} * *frequency_response* (see Frequency Response Chart). This linearization is implemented in DASY4 software versions later than 4.2. The uncertainty of the frequency response is included in the stated uncertainty of *ConvF*.
- DCP_{x,y,z}**: DCP are numerical linearization parameters assessed based on the data of power sweep (no uncertainty required). DCP does not depend on frequency nor media.
- ConvF and Boundary Effect Parameters**: Assessed in flat phantom using E-field (or Temperature Transfer Standard for $f \leq 800$ MHz) and inside waveguide using analytical field distributions based on power measurements for $f > 800$ MHz. The same setups are used for assessment of the parameters applied for boundary compensation (alpha, depth) of which typical uncertainty values are given. These parameters are used in DASY4 software to improve probe accuracy close to the boundary. The sensitivity in TSL corresponds to NORM_{x,y,z} * *ConvF* whereby the uncertainty corresponds to that given for *ConvF*. A frequency dependent *ConvF* is used in DASY version 4.4 and higher which allows extending the validity from ± 50 MHz to ± 100 MHz.
- Spherical isotropy (3D deviation from isotropy)**: in a field of low gradients realized using a flat phantom exposed by a patch antenna.
- Sensor Offset**: The sensor offset corresponds to the offset of virtual measurement center from the probe tip (on probe axis). No tolerance required.

Probe ET3DV6

SN:1790

Manufactured:	May 28, 2003
Last calibrated:	December 20, 2004
Recalibrated:	November 23, 2006

Calibrated for DASY Systems

(Note: non-compatible with DASY2 system!)

DASY - Parameters of Probe: ET3DV6 SN:1790**Sensitivity in Free Space^A****Diode Compression^B**

NormX	2.04 ± 10.1%	$\mu\text{V}/(\text{V}/\text{m})^2$	DCP X	91 mV
NormY	2.10 ± 10.1%	$\mu\text{V}/(\text{V}/\text{m})^2$	DCP Y	93 mV
NormZ	1.84 ± 10.1%	$\mu\text{V}/(\text{V}/\text{m})^2$	DCP Z	98 mV

Sensitivity in Tissue Simulating Liquid (Conversion Factors)

Please see Page 8.

Boundary Effect**TSL 900 MHz Typical SAR gradient: 5 % per mm**

Sensor Center to Phantom Surface Distance		3.7 mm	4.7 mm
SAR _{be} [%]	Without Correction Algorithm	9.2	4.9
SAR _{be} [%]	With Correction Algorithm	0.1	0.2

TSL 1750 MHz Typical SAR gradient: 10 % per mm

Sensor Center to Phantom Surface Distance		3.7 mm	4.7 mm
SAR _{be} [%]	Without Correction Algorithm	12.6	8.4
SAR _{be} [%]	With Correction Algorithm	0.5	0.0

Sensor OffsetProbe Tip to Sensor Center **2.7 mm**

The reported uncertainty of measurement is stated as the standard uncertainty of measurement multiplied by the coverage factor k=2, which for a normal distribution corresponds to a coverage probability of approximately 95%.

^A The uncertainties of NormX,Y,Z do not affect the E²-field uncertainty inside TSL (see Page 8).^B Numerical linearization parameter: uncertainty not required.

Frequency Response of E-Field

(TEM-Cell:ifi110 EXX, Waveguide: R22)

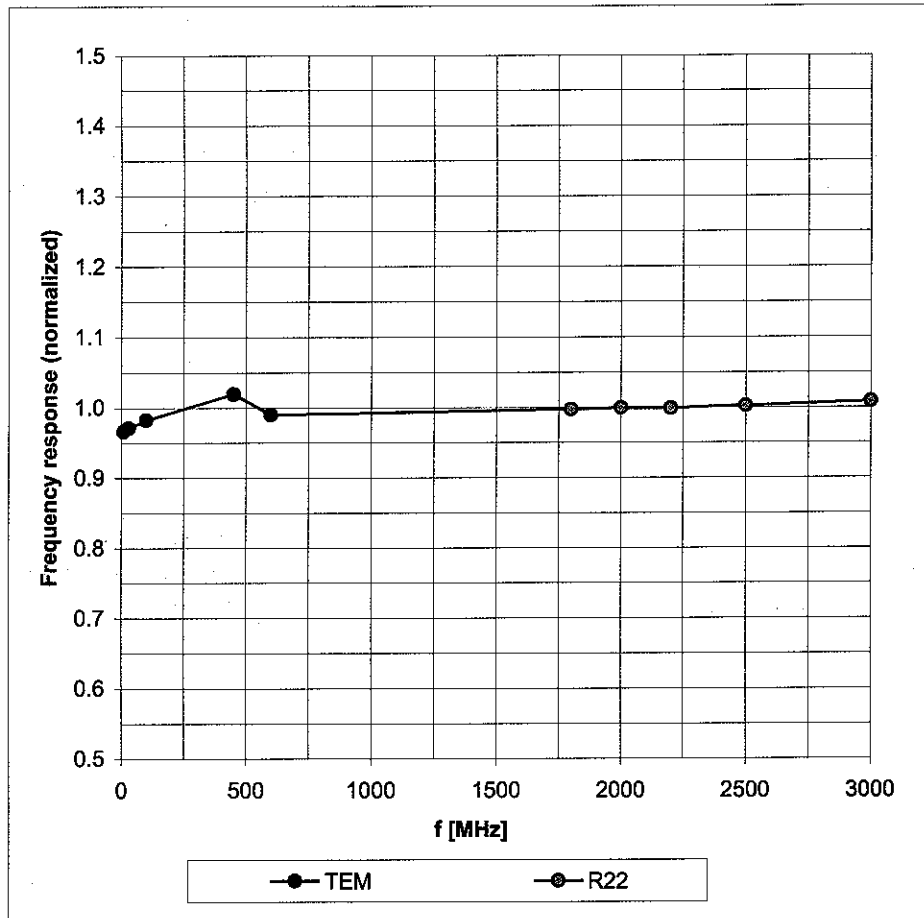

Uncertainty of Frequency Response of E-field: $\pm 6.3\%$ (k=2)

Receiving Pattern (ϕ), $\theta = 0^\circ$

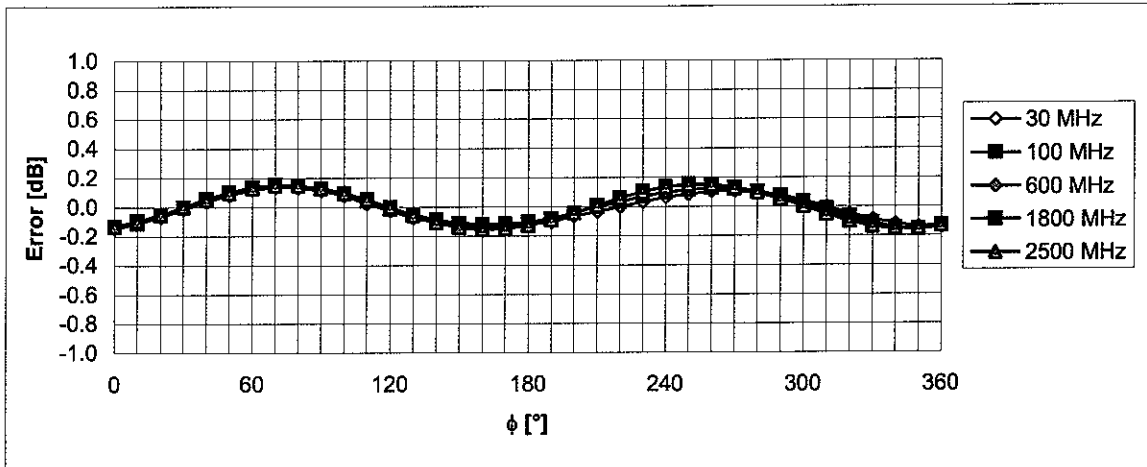
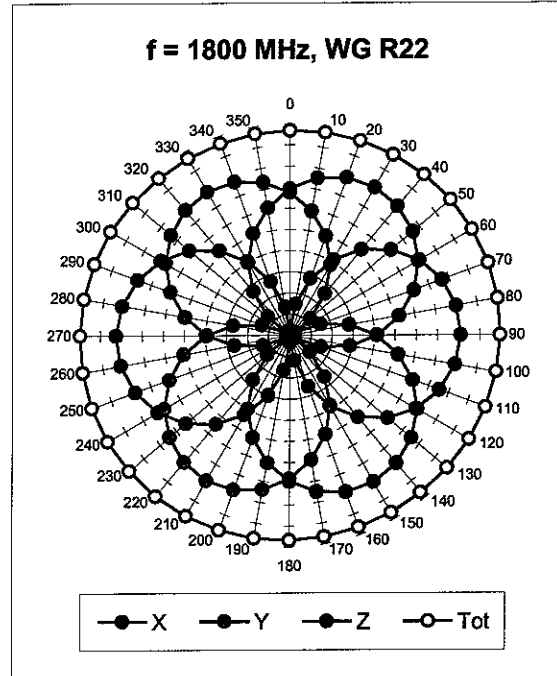
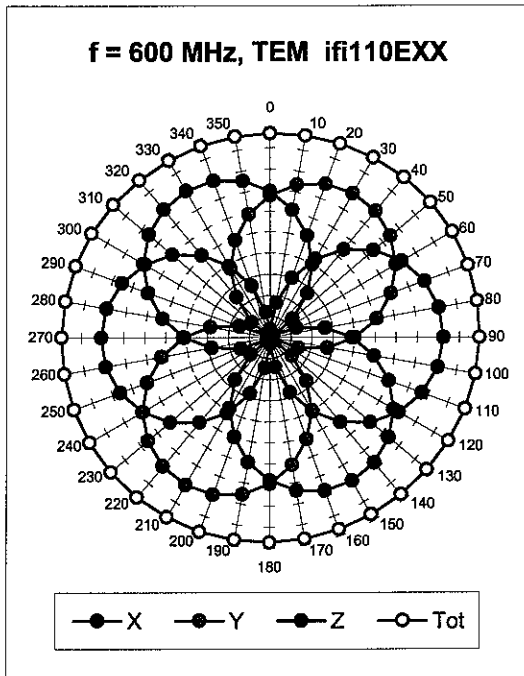

Uncertainty of Axial Isotropy Assessment: $\pm 0.5\%$ (k=2)

Dynamic Range $f(\text{SAR}_{\text{head}})$ (Waveguide R22, $f = 1800 \text{ MHz}$)

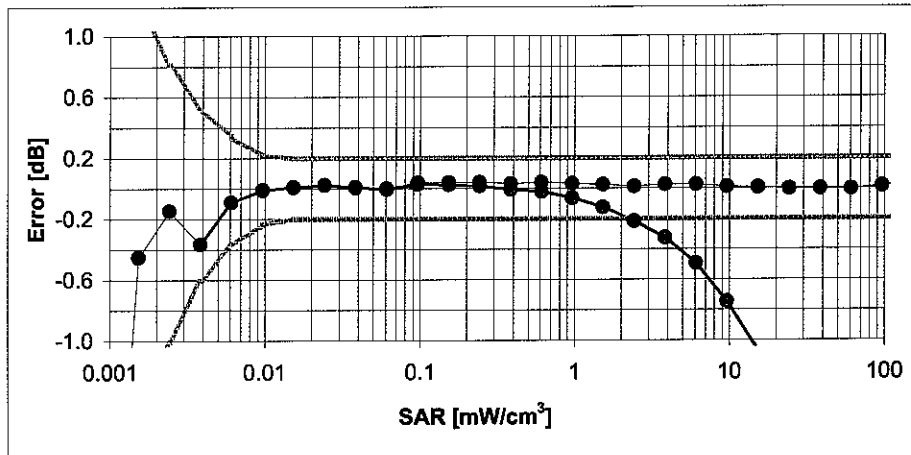
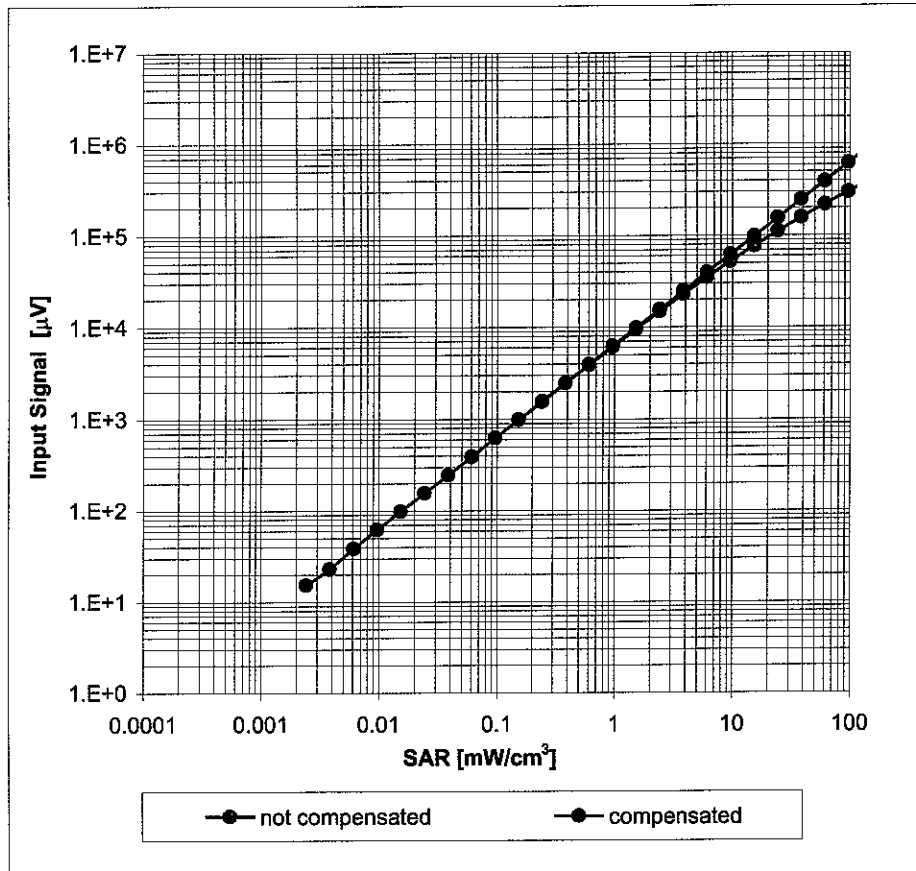

Uncertainty of Linearity Assessment: $\pm 0.6\%$ ($k=2$)

Conversion Factor Assessment

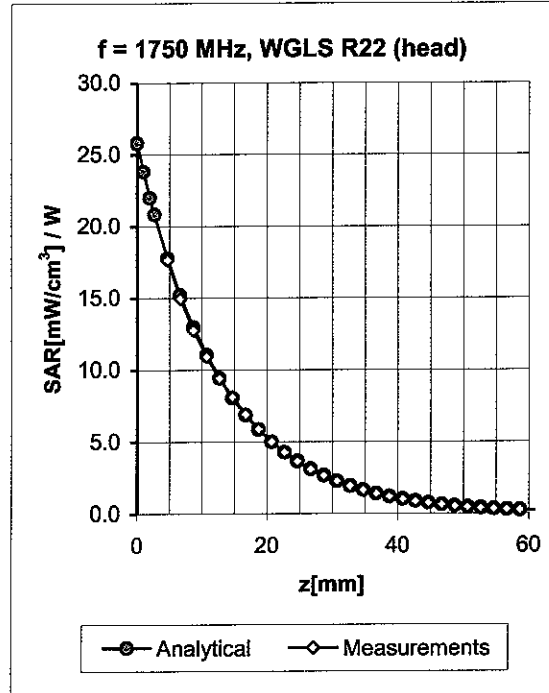
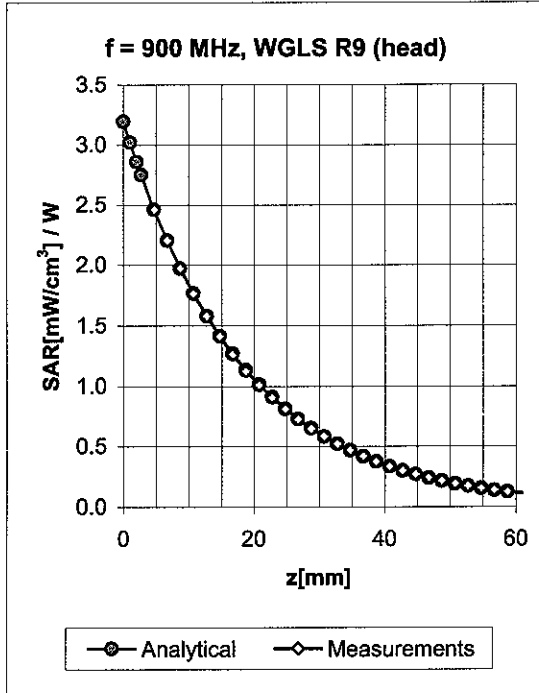

f [MHz]	Validity [MHz] ^c	TSL	Permittivity	Conductivity	Alpha	Depth	ConvF Uncertainty
900	± 50 / ± 100	Head	41.5 ± 5%	0.97 ± 5%	0.32	2.45	6.71 ± 11.0% (k=2)
1750	± 50 / ± 100	Head	40.1 ± 5%	1.37 ± 5%	0.50	2.47	5.48 ± 11.0% (k=2)
1950	± 50 / ± 100	Head	40.0 ± 5%	1.40 ± 5%	0.57	2.47	5.27 ± 11.0% (k=2)
2450	± 50 / ± 100	Head	39.2 ± 5%	1.80 ± 5%	0.66	1.94	4.76 ± 11.8% (k=2)
900	± 50 / ± 100	Body	55.0 ± 5%	1.05 ± 5%	0.32	2.78	6.35 ± 11.0% (k=2)
1750	± 50 / ± 100	Body	53.4 ± 5%	1.49 ± 5%	0.55	2.76	4.85 ± 11.0% (k=2)
1950	± 50 / ± 100	Body	53.3 ± 5%	1.52 ± 5%	0.70	2.39	4.59 ± 11.0% (k=2)
2450	± 50 / ± 100	Body	52.7 ± 5%	1.95 ± 5%	0.64	1.81	4.35 ± 11.8% (k=2)

^c The validity of ± 100 MHz only applies for DASY v4.4 and higher (see Page 2). The uncertainty is the RSS of the ConvF uncertainty at calibration frequency and the uncertainty for the indicated frequency band.

Deviation from Isotropy in HSL

Error (ϕ, θ), $f = 900$ MHz

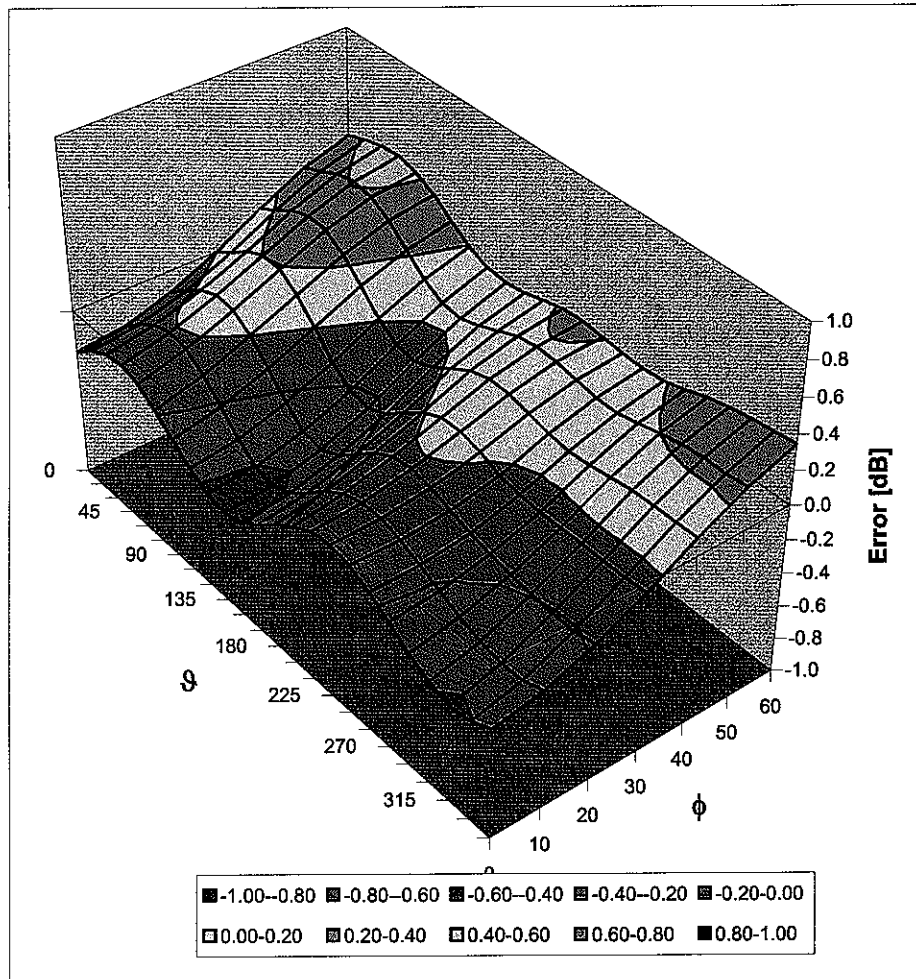

Uncertainty of Spherical Isotropy Assessment: $\pm 2.6\%$ ($k=2$)



D3: DAE



Accredited by the Swiss Federal Office of Metrology and Accreditation
The Swiss Accreditation Service is one of the signatories to the EA
Multilateral Agreement for the recognition of calibration certificates

Accreditation No.: **SCS 108**

Client **ADT (Auden)**

Certificate No: **DAE3-510_Sep06**

CALIBRATION CERTIFICATE

Object **DAE3 - SD 000 D03 AA - SN: 510**

Calibration procedure(s) **QA CAL-06.v12
Calibration procedure for the data acquisition electronics (DAE)**

Calibration date: **September 07, 2006**

Condition of the calibrated item **In Tolerance**

This calibration certificate documents the traceability to national standards, which realize the physical units of measurements (SI).
The measurements and the uncertainties with confidence probability are given on the following pages and are part of the certificate.

All calibrations have been conducted in the closed laboratory facility: environment temperature (22 ± 3)°C and humidity < 70%.

Calibration Equipment used (M&TE critical for calibration)

Primary Standards	ID #	Cal Date (Calibrated by, Certificate No.)	Scheduled Calibration
Fluke Process Calibrator Type 702	SN: 6295803	7-Oct-05 (Sintrel, No.E-050073)	Oct-06
Secondary Standards	ID #	Check Date (in house)	Scheduled Check
Calibrator Box V1.1	SE UMS 006 AB 1002	15-Jun-06 (SPEAG, in house check)	In house check Jun-07

Calibrated by: Name **Daniel Steinacher** Function **Technician** Signature *Daniel Steinacher*

Approved by: **Fin Bornholt** R&D Director *Fin Bornholt*

Issued: September 7, 2006

This calibration certificate shall not be reproduced except in full without written approval of the laboratory.



Accredited by the Swiss Federal Office of Metrology and Accreditation
The Swiss Accreditation Service is one of the signatories to the EA
Multilateral Agreement for the recognition of calibration certificates

Accreditation No.: **SCS 108**

Glossary

DAE data acquisition electronics
Connector angle information used in DASY system to align probe sensor X to the robot coordinate system.

Methods Applied and Interpretation of Parameters

- **DC Voltage Measurement:** Calibration Factor assessed for use in DASY system by comparison with a calibrated instrument traceable to national standards. The figure given corresponds to the full scale range of the voltmeter in the respective range.
- **Connector angle:** The angle of the connector is assessed measuring the angle mechanically by a tool inserted. Uncertainty is not required.
- The following parameters contain technical information as a result from the performance test and require no uncertainty.
- **DC Voltage Measurement Linearity:** Verification of the Linearity at +10% and -10% of the nominal calibration voltage. Influence of offset voltage is included in this measurement.
- **Common mode sensitivity:** Influence of a positive or negative common mode voltage on the differential measurement.
- **Channel separation:** Influence of a voltage on the neighbor channels not subject to an input voltage.
- **AD Converter Values with inputs shorted:** Values on the internal AD converter corresponding to zero input voltage
- **Input Offset Measurement:** Output voltage and statistical results over a large number of zero voltage measurements.
- **Input Offset Current:** Typical value for information; Maximum channel input offset current, not considering the input resistance.
- **Input resistance:** DAE input resistance at the connector, during internal auto-zeroing and during measurement.
- **Low Battery Alarm Voltage:** Typical value for information. Below this voltage, a battery alarm signal is generated.
- **Power consumption:** Typical value for information. Supply currents in various operating modes.

DC Voltage Measurement

A/D - Converter Resolution nominal

High Range: 1LSB = 6.1 μ V, full range = -100...+300 mV

Low Range: 1LSB = 61nV, full range = -1.....+3mV

DASY measurement parameters: Auto Zero Time: 3 sec; Measuring time: 3 sec

Calibration Factors	X	Y	Z
High Range	404.194 \pm 0.1% (k=2)	404.254 \pm 0.1% (k=2)	404.622 \pm 0.1% (k=2)
Low Range	3.97522 \pm 0.7% (k=2)	3.96545 \pm 0.7% (k=2)	3.95957 \pm 0.7% (k=2)

Connector Angle

Connector Angle to be used in DASY system	42 $^{\circ}$ \pm 1 $^{\circ}$
---	----------------------------------

Appendix

1. DC Voltage Linearity

High Range		Input (μV)	Reading (μV)	Error (%)
Channel X	+ Input	200000	200000.2	0.00
Channel X	+ Input	20000	20007.72	0.04
Channel X	- Input	20000	-19999.52	0.00
Channel Y	+ Input	200000	199999.5	0.00
Channel Y	+ Input	20000	20005.14	0.03
Channel Y	- Input	20000	-20000.72	0.00
Channel Z	+ Input	200000	200000.5	0.00
Channel Z	+ Input	20000	20006.06	0.03
Channel Z	- Input	20000	-20002.05	0.01

Low Range		Input (μV)	Reading (μV)	Error (%)
Channel X	+ Input	2000	1999.9	0.00
Channel X	+ Input	200	200.02	0.01
Channel X	- Input	200	-200.32	0.16
Channel Y	+ Input	2000	2000.0	0.00
Channel Y	+ Input	200	199.46	-0.27
Channel Y	- Input	200	-200.72	0.36
Channel Z	+ Input	2000	1999.9	0.00
Channel Z	+ Input	200	199.12	-0.44
Channel Z	- Input	200	-201.06	0.53

2. Common mode sensitivity

DASY measurement parameters: Auto Zero Time: 3 sec; Measuring time: 3 sec

	Common mode Input Voltage (mV)	High Range Average Reading (μV)	Low Range Average Reading (μV)
Channel X	200	17.19	16.90
	- 200	-16.29	-16.91
Channel Y	200	14.52	14.16
	- 200	-15.49	-15.51
Channel Z	200	-8.86	-9.32
	- 200	7.79	7.80

3. Channel separation

DASY measurement parameters: Auto Zero Time: 3 sec; Measuring time: 3 sec

	Input Voltage (mV)	Channel X (μV)	Channel Y (μV)	Channel Z (μV)
Channel X	200	-	1.86	-0.06
Channel Y	200	0.60	-	4.31
Channel Z	200	-2.51	-0.39	-

4. AD-Converter Values with inputs shorted

DASY measurement parameters: Auto Zero Time: 3 sec; Measuring time: 3 sec

	High Range (LSB)	Low Range (LSB)
Channel X	15894	16343
Channel Y	16116	16300
Channel Z	16080	16129

5. Input Offset Measurement

DASY measurement parameters: Auto Zero Time: 3 sec; Measuring time: 3 sec

Input 10MΩ

	Average (μV)	min. Offset (μV)	max. Offset (μV)	Std. Deviation (μV)
Channel X	0.39	-0.84	1.32	0.26
Channel Y	-1.02	-1.58	0.05	0.26
Channel Z	0.18	-0.50	1.13	0.28

6. Input Offset Current

Nominal Input circuitry offset current on all channels: <25fA

7. Input Resistance

	Zeroing (MΩ)	Measuring (MΩ)
Channel X	0.2001	199.6
Channel Y	0.2001	198.3
Channel Z	0.2001	199.1

8. Low Battery Alarm Voltage (verified during pre test)

Typical values	Alarm Level (VDC)
Supply (+ Vcc)	+7.9
Supply (- Vcc)	-7.6

9. Power Consumption (verified during pre test)

Typical values	Switched off (mA)	Stand by (mA)	Transmitting (mA)
Supply (+ Vcc)	+0.0	+6	+14
Supply (- Vcc)	-0.01	-8	-9



D4: SYSTEM VALIDATION DIPOLE



Accredited by the Swiss Federal Office of Metrology and Accreditation
The Swiss Accreditation Service is one of the signatories to the EA
Multilateral Agreement for the recognition of calibration certificates

Accreditation No.: **SCS 108**

Client **ADT (Auden)**

Certificate No: **D2450V2-716_Aug06**

CALIBRATION CERTIFICATE

Object **D2450V2 - SN: 716**

Calibration procedure(s) **QA CAL-05.v6
Calibration procedure for dipole validation kits**

Calibration date: **August 21, 2006**

Condition of the calibrated item **In Tolerance**

This calibration certificate documents the traceability to national standards, which realize the physical units of measurements (SI).
The measurements and the uncertainties with confidence probability are given on the following pages and are part of the certificate.

All calibrations have been conducted in the closed laboratory facility: environment temperature (22 ± 3)°C and humidity < 70%.

Calibration Equipment used (M&TE critical for calibration)

Primary Standards	ID #	Cal Date (Calibrated by, Certificate No.)	Scheduled Calibration
Power meter EPM-442A	GB37480704	04-Oct-05 (METAS, No. 251-00516)	Oct-06
Power sensor HP 8481A	US37292783	04-Oct-05 (METAS, No. 251-00516)	Oct-06
Reference 20 dB Attenuator	SN: 5086 (20g)	10-Aug-06 (METAS, No 217-00591)	Aug-07
Reference 10 dB Attenuator	SN: 5047.2 (10r)	10-Aug-06 (METAS, No 217-00591)	Aug-07
Reference Probe ES3DV2	SN 3025	28-Oct-05 (SPEAG, No. ES3-3025_Oct05)	Oct-06
DAE4	SN 601	15-Dec-05 (SPEAG, No. DAE4-601_Dec05)	Dec-06
Secondary Standards	ID #	Check Date (in house)	Scheduled Check
Power sensor HP 8481A	MY41092317	18-Oct-02 (SPEAG, in house check Oct-05)	In house check: Oct-07
RF generator Agilent E4421B	MY41000675	11-May-05 (SPEAG, in house check Nov-05)	In house check: Nov-07
Network Analyzer HP 8753E	US37390585 S4206	18-Oct-01 (SPEAG, in house check Nov-05)	In house check: Nov-06

Calibrated by: **Name** Mike Meili **Function** Laboratory Technician **Signature** *M. Meili*

Approved by: **Name** Katja Pokovic **Function** Technical Manager

Katja Pokovic
Issued: August 22, 2006

This calibration certificate shall not be reproduced except in full without written approval of the laboratory.



Accredited by the Swiss Federal Office of Metrology and Accreditation
The Swiss Accreditation Service is one of the signatories to the EA
Multilateral Agreement for the recognition of calibration certificates

Accreditation No.: **SCS 108**

Glossary:

TSL	tissue simulating liquid
ConvF	sensitivity in TSL / NORM x,y,z
N/A	not applicable or not measured

Calibration is Performed According to the Following Standards:

- IEEE Std 1528-2003, "IEEE Recommended Practice for Determining the Peak Spatial-Averaged Specific Absorption Rate (SAR) in the Human Head from Wireless Communications Devices: Measurement Techniques", December 2003
- CENELEC EN 50361, "Basic standard for the measurement of Specific Absorption Rate related to human exposure to electromagnetic fields from mobile phones (300 MHz - 3 GHz), July 2001
- Federal Communications Commission Office of Engineering & Technology (FCC OET), "Evaluating Compliance with FCC Guidelines for Human Exposure to Radiofrequency Electromagnetic Fields; Additional Information for Evaluating Compliance of Mobile and Portable Devices with FCC Limits for Human Exposure to Radiofrequency Emissions", Supplement C (Edition 01-01) to Bulletin 65

Additional Documentation:

- DASY4 System Handbook

Methods Applied and Interpretation of Parameters:

- Measurement Conditions:** Further details are available from the Validation Report at the end of the certificate. All figures stated in the certificate are valid at the frequency indicated.
- Antenna Parameters with TSL:** The dipole is mounted with the spacer to position its feed point exactly below the center marking of the flat phantom section, with the arms oriented parallel to the body axis.
- Feed Point Impedance and Return Loss:** These parameters are measured with the dipole positioned under the liquid filled phantom. The impedance stated is transformed from the measurement at the SMA connector to the feed point. The Return Loss ensures low reflected power. No uncertainty required.
- Electrical Delay:** One-way delay between the SMA connector and the antenna feed point. No uncertainty required.
- SAR measured:** SAR measured at the stated antenna input power.
- SAR normalized:** SAR as measured, normalized to an input power of 1 W at the antenna connector.
- SAR for nominal TSL parameters:** The measured TSL parameters are used to calculate the nominal SAR result.

Measurement Conditions

DASY system configuration, as far as not given on page 1.

DASY Version	DASY4	V4.7
Extrapolation	Advanced Extrapolation	
Phantom	Modular Flat Phantom V5.0	
Distance Dipole Center - TSL	10 mm	with Spacer
Zoom Scan Resolution	dx, dy, dz = 5 mm	
Frequency	2450 MHz \pm 1 MHz	

Head TSL parameters

The following parameters and calculations were applied.

	Temperature	Permittivity	Conductivity
Nominal Head TSL parameters	22.0 °C	39.2	1.80 mho/m
Measured Head TSL parameters	(22.0 \pm 0.2) °C	39.8 \pm 6 %	1.80 mho/m \pm 6 %
Head TSL temperature during test	(22.7 \pm 0.2) °C	-----	-----

SAR result with Head TSL

SAR averaged over 1 cm ³ (1 g) of Head TSL	condition	
SAR measured	250 mW input power	14.0 mW / g
SAR normalized	normalized to 1W	56.0 mW / g
SAR for nominal Head TSL parameters ¹	normalized to 1W	56.4 mW / g \pm 17.0 % (k=2)

SAR averaged over 10 cm ³ (10 g) of Head TSL	condition	
SAR measured	250 mW input power	6.53 mW / g
SAR normalized	normalized to 1W	26.1 mW / g
SAR for nominal Head TSL parameters ¹	normalized to 1W	26.3 mW / g \pm 16.5 % (k=2)

¹ Correction to nominal TSL parameters according to d), chapter "SAR Sensitivities"

Body TSL parameters

The following parameters and calculations were applied.

	Temperature	Permittivity	Conductivity
Nominal Body TSL parameters	22.0 °C	52.7	1.95 mho/m
Measured Body TSL parameters	(22.0 ± 0.2) °C	52.1 ± 6 %	1.97 mho/m ± 6 %
Body TSL temperature during test	(23.4 ± 0.2) °C	----	----

SAR result with Body TSL

SAR averaged over 1 cm ³ (1 g) of Body TSL	Condition	
SAR measured	250 mW input power	13.4 mW / g
SAR normalized	normalized to 1W	53.6 mW / g
SAR for nominal Body TSL parameters ²	normalized to 1W	53.0 mW / g ± 17.0 % (k=2)

SAR averaged over 10 cm ³ (10 g) of Body TSL	Condition	
SAR measured	250 mW input power	6.20 mW / g
SAR normalized	normalized to 1W	24.8 mW / g
SAR for nominal Body TSL parameters ²	normalized to 1W	24.6 mW / g ± 16.5 % (k=2)

² Correction to nominal TSL parameters according to d), chapter "SAR Sensitivities"

Appendix

Antenna Parameters with Head TSL

Impedance, transformed to feed point	54.2 Ω + 1.9 j Ω
Return Loss	- 27.0 dB

Antenna Parameters with Body TSL

Impedance, transformed to feed point	49.7 Ω + 3.7 j Ω
Return Loss	- 28.7 dB

General Antenna Parameters and Design

Electrical Delay (one direction)	1.147 ns
----------------------------------	----------

After long term use with 100W radiated power, only a slight warming of the dipole near the feedpoint can be measured.

The dipole is made of standard semirigid coaxial cable. The center conductor of the feeding line is directly connected to the second arm of the dipole. The antenna is therefore short-circuited for DC-signals.

No excessive force must be applied to the dipole arms, because they might bend or the soldered connections near the feedpoint may be damaged.

Additional EUT Data

Manufactured by	SPEAG
Manufactured on	September 10, 2002

DASY4 Validation Report for Head TSL

Date/Time: 21.08.2006 14:39:00

Test Laboratory: SPEAG, Zurich, Switzerland

DUT: Dipole 2450 MHz; Type: D2450V2; Serial: D2450V2 - SN716

Communication System: CW-2450; Frequency: 2450 MHz; Duty Cycle: 1:1

Medium: HSL U10 BB_060425;

Medium parameters used: $f = 2450$ MHz; $\sigma = 1.84$ mho/m; $\epsilon_r = 39.8$; $\rho = 1000$ kg/m³

Phantom section: Flat Section

Measurement Standard: DASY4 (High Precision Assessment)

DASY4 Configuration:

- Probe: ES3DV2 - SN3025 (HF); ConvF(4.4, 4.4, 4.4); Calibrated: 28.10.2005
- Sensor-Surface: 4mm (Mechanical Surface Detection)
- Electronics: DAE4 Sn601; Calibrated: 15.12.2005
- Phantom: Flat Phantom 5.0 (front); Type: QD000P50AA
- Measurement SW: DASY4, V4.7 Build 44; Postprocessing SW: SEMCAD, V1.8 Build 171

Pin = 250 mW; d = 10 mm 2/Zoom Scan (7x7x7)/Cube 0:

Measurement grid: dx=5mm, dy=5mm, dz=5mm

Reference Value = 89.6 V/m; Power Drift = 0.022 dB

Peak SAR (extrapolated) = 28.9 W/kg

SAR(1 g) = 14 mW/g; SAR(10 g) = 6.53 mW/g

Maximum value of SAR (measured) = 15.5 mW/g

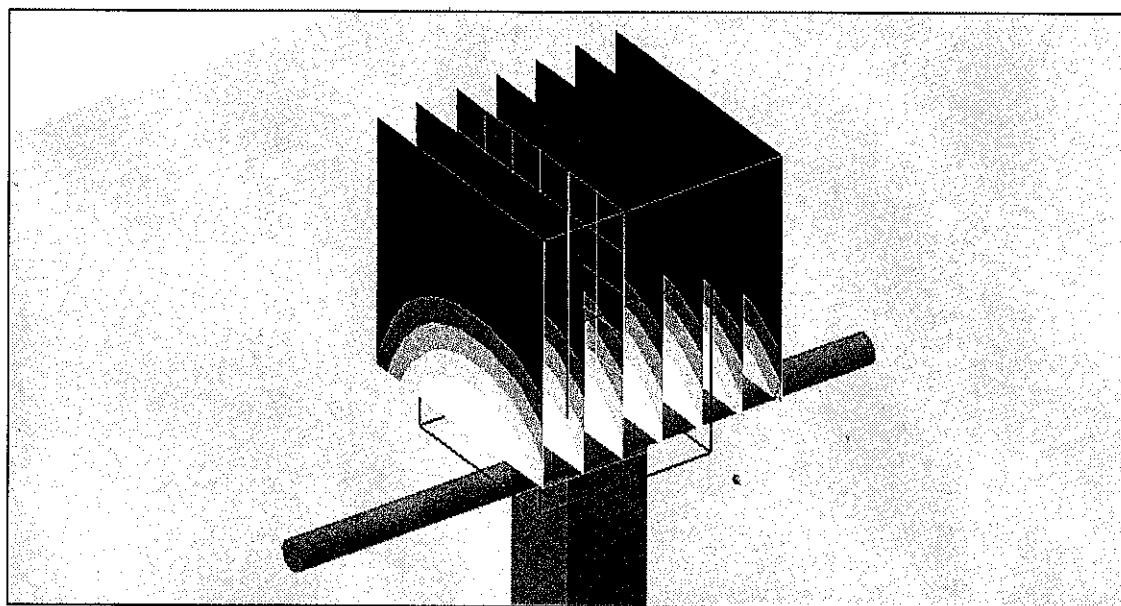

0 dB = 15.5mW/g

Impedance Measurement Plot for Head TSL

21 Aug 2006 10:09:29

CH1 S11 1 U FS 1: 54.230 Ω 1.9141 Ω 124.34 μH 2 450.000 000 MHz

*
Del
Cor

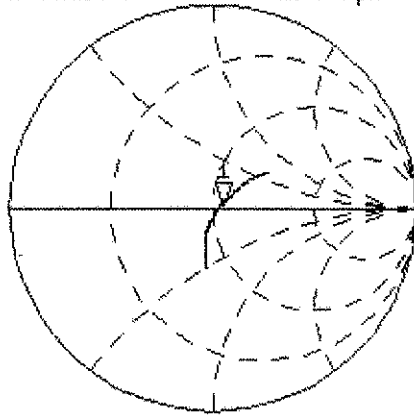

Avg
16

CH2 S11 LOG 3 dB/REF -20 dB 1: -27.021 dB 2 450.000 000 MHz

Cor

Avg
16

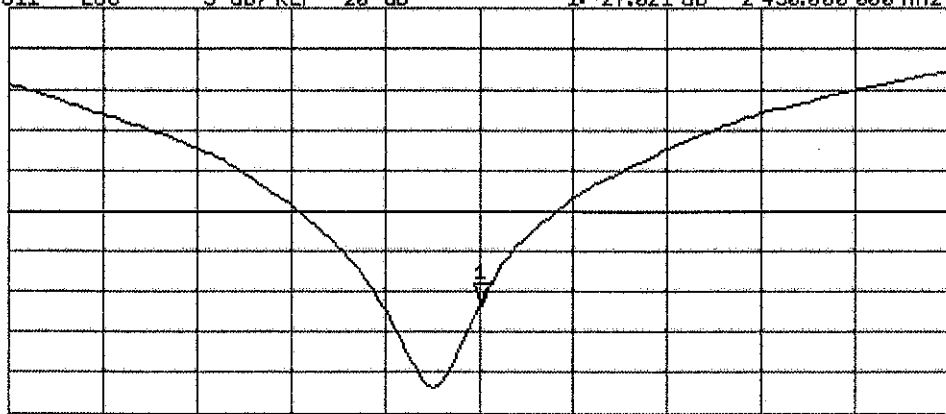

START 2 250.000 000 MHz

STOP 2 650.000 000 MHz

DASY4 Validation Report for Body TSL

Date/Time: 21.08.2006 16:08:52

Test Laboratory: SPEAG, Zurich, Switzerland

DUT: Dipole 2450 MHz; Type: D2450V2; Serial: D2450V2 - SN716

Communication System: CW-2450; Frequency: 2450 MHz; Duty Cycle: 1:1

Medium: MSL U10;

Medium parameters used: $f = 2450$ MHz; $\sigma = 1.96$ mho/m; $\epsilon_r = 51.9$; $\rho = 1000$ kg/m³

Phantom section: Flat Section

Measurement Standard: DASY4 (High Precision Assessment)

DASY4 Configuration:

- Probe: ES3DV2 - SN3025 (HF); ConvF(4.06, 4.06, 4.06); Calibrated: 28.10.2005
- Sensor-Surface: 4mm (Mechanical Surface Detection)
- Electronics: DAE4 Sn601; Calibrated: 15.12.2005
- Phantom: Flat Phantom 5.0 (back); Type: QD000P50AA
- Measurement SW: DASY4, V4.7 Build 44; Postprocessing SW: SEMCAD, V1.8 Build 171

Pin = 250 mW; d = 10 mm/Zoom Scan (7x7x7)/Cube 0:

Measurement grid: dx=5mm, dy=5mm, dz=5mm

Reference Value = 87.4 V/m; Power Drift = 0.018 dB

Peak SAR (extrapolated) = 28.8 W/kg

SAR(1 g) = 13.4 mW/g; SAR(10 g) = 6.2 mW/g

Maximum value of SAR (measured) = 14.8 mW/g

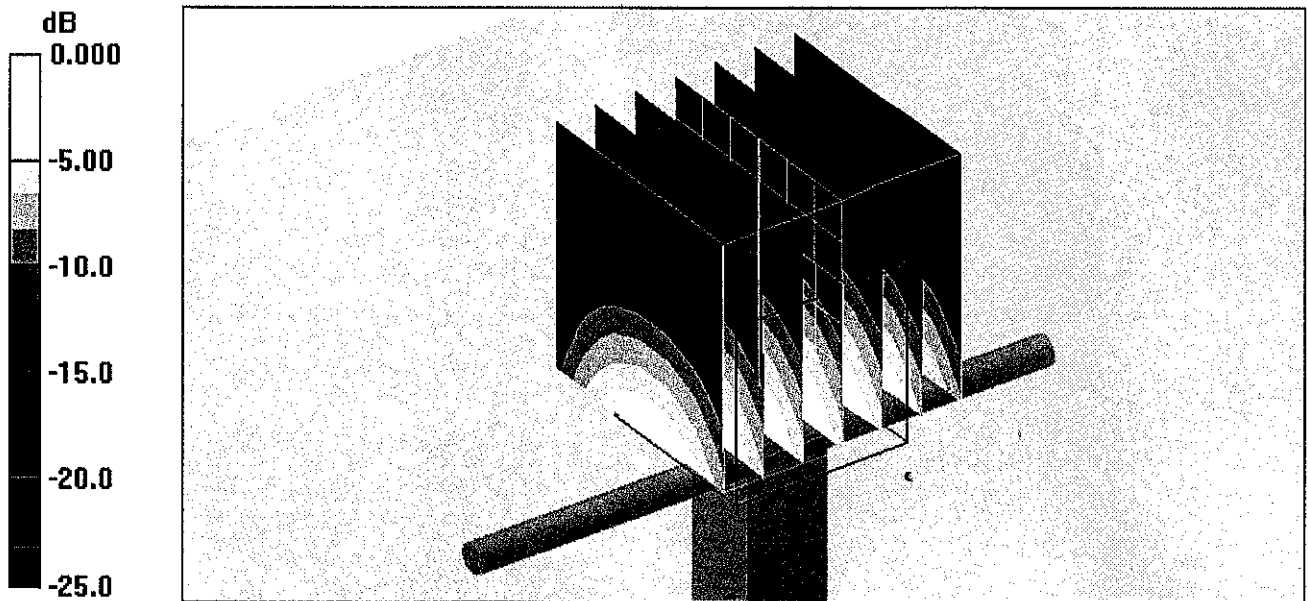

0 dB = 14.8mW/g

Impedance Measurement Plot for Body TSL

21 Aug 2006 10:10:19

CH1 S11 1 U FS 1: 49.654 Ω 3.6621 Ω 237.90 μH 2 450.000 000 MHz

*
Del
Cor

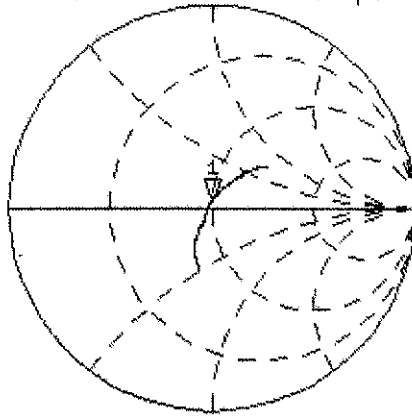

Avg
16

↑

CH2 S11 LOG 3 dB/REF -20 dB 1: -28.665 dB 2 450.000 000 MHz

Cor

Avg
16

↑

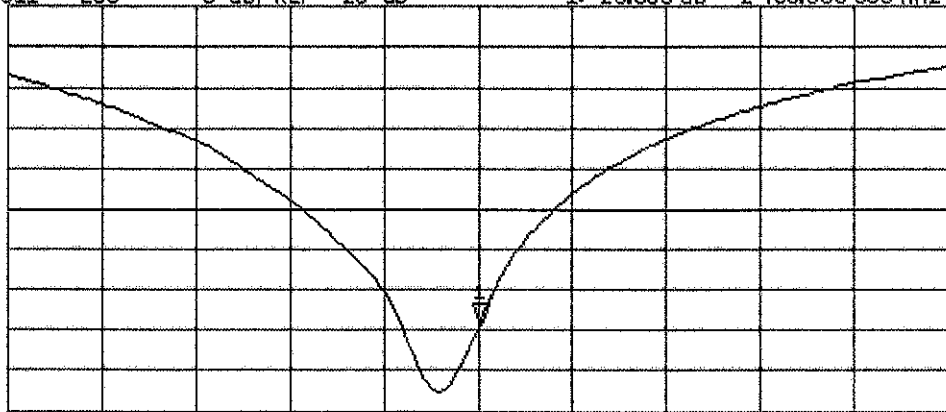

START 2 250.000 000 MHz

STOP 2 650.000 000 MHz