



FCC TEST REPORT

REPORT NO.: RF940310L13A

MODEL NO.: WCB-210A

RECEIVED: May 05, 2005

TESTED: May 10 ~ May 13, 2005

ISSUED: May 18, 2005

APPLICANT: U-MEDIA Communications, Inc.

ADDRESS: 9F, No. 1, Jin-shan 7th St., Hsinchu 300, Taiwan,
R.O.C.

ISSUED BY: Advance Data Technology Corporation

LAB ADDRESS: No. 47, 14th Ling, Chia Pau Tsuen, Lin Kou
Hsiang 244, Taipei Hsien, Taiwan, R.O.C.

TEST LOCATION: No. 19, Hwa Ya 2nd Rd., Wen Hwa Tsuen, Kwei
Shan Hsiang, Taoyuan Hsien 333, Taiwan,
R.O.C.

This test report consists of 44 pages in total. It may be duplicated completely for legal use with the approval of the applicant. It should not be reproduced except in full, without the written approval of our laboratory. The client should not use it to claim product endorsement by CNLA, A2LA or any government agencies. The test results in the report only apply to the tested sample.



0528
ILAC MRA



No. 2177-01



Table of Contents

1.	CERTIFICATION	3
2.	SUMMARY OF TEST RESULTS	4
2.1	MEASUREMENT UNCERTAINTY	4
3.	GENERAL INFORMATION.....	5
3.1	GENERAL DESCRIPTION OF EUT.....	5
3.1.1	DESCRIPTION OF EUT difference.....	5
3.2	DESCRIPTION OF TEST MODES.....	6
3.2.1	CONFIGURATION OF SYSTEM UNDER TEST.....	6
3.2.2	Test Mode Applicability and tested channel detail:.....	7
3.3	GENERAL DESCRIPTION OF APPLIED STANDARDS	9
3.4	DESCRIPTION OF SUPPORT UNITS	9
4.	TEST TYPES AND RESULTS	10
4.1	CONDUCTED EMISSION MEASUREMENT	10
4.1.1	LIMITS OF CONDUCTED EMISSION MEASUREMENT	10
4.1.2	TEST INSTRUMENTS	10
4.1.3	TEST PROCEDURES.....	11
4.1.4	DEVIATION FROM TEST STANDARD	11
4.1.5	TEST SETUP	12
4.1.6	EUT OPERATING CONDITIONS.....	12
4.1.7	TEST RESULTS	13
4.2	RADIATED EMISSION MEASUREMENT	19
4.2.1	LIMITS OF RADIATED EMISSION MEASUREMENT	19
4.2.2	TEST INSTRUMENTS	20
4.2.3	TEST PROCEDURES.....	21
4.2.4	DEVIATION FROM TEST STANDARD	21
4.2.5	TEST SETUP	22
4.2.6	EUT OPERATING CONDITIONS.....	22
4.2.7	TEST RESULTS	23
4.3	MAXIMUM PEAK OUTPUT POWER	30
4.3.1	LIMITS OF MAXIMUM PEAK OUTPUT POWER MEASUREMENT	30
4.3.2	INSTRUMENTS.....	30
4.3.3	TEST PROCEDURES.....	31
4.3.4	DEVIATION FROM TEST STANDARD	31
4.3.5	TEST SETUP	31
4.3.6	EUT OPERATING CONDITIONS.....	31
4.3.7	TEST RESULTS	32
4.4	BAND EDGES MEASUREMENT	33
4.4.1	LIMITS OF BAND EDGES MEASUREMENT	33
4.4.2	TEST INSTRUMENTS	33
4.4.3	TEST PROCEDURE	33
4.4.4	DEVIATION FROM TEST STANDARD	33
4.4.5	EUT OPERATING CONDITION	33
4.4.6	TEST RESULTS	34
4.4.7	TEST RESULTS	34
5.	PHOTOGRAPHS OF THE TEST CONFIGURATION.....	42
6.	INFORMATION ON THE TESTING LABORATORIES	44



1. CERTIFICATION

PRODUCT: Wireless 802.11g Cardbus Card
BRAND NAME: U-MEDIA
MODEL NO.: WCB-210A
TEST SAMPLE: ENGINEERING SAMPLE
TESTED: May 10 ~ May 13, 2005
APPLICANT: U-MEDIA Communications, Inc.
STANDARDS: FCC Part 15, Subpart C (Section 15.247),
ANSI C63.4-2003

The above equipment have been tested by **Advance Data Technology Corporation**, and found compliance with the requirement of the above standards. The test record, data evaluation & Equipment Under Test (EUT) configurations represented herein are true and accurate accounts of the measurements of the sample's EMC characteristics under the conditions specified in this report.

PREPARED BY : Wendy Liao , **DATE:** May 18, 2005
(Wendy Liao)

TECHNICAL
ACCEPTANCE : Gary Chang , **DATE:** May 18, 2005
Responsible for RF (Gary Chang)

APPROVED BY : Cody Chang , **DATE:** May 18, 2005
(Cody Chang, Deputy Manager)

2. SUMMARY OF TEST RESULTS

The EUT has been tested according to the following specifications:

APPLIED STANDARD: FCC Part 15, Subpart C			
Standard Section	Test Type and Limit	Result	Remark
15.207	AC Power Conducted Emission	PASS	Meet the requirement of limit. Minimum passing margin is -18.05dB at 0.220MHz
15.247(a)(2)	Spectrum Bandwidth of a Direct Sequence Spread Spectrum System Limit: min. 500kHz	PASS	Meet the requirement of limit.
15.247(b)	Maximum Peak Output Power Limit: max. 30dBm	PASS	Meet the requirement of limit.
15.247(d)	Radiated Emissions Limit: Table 15.209	PASS	Meet the requirement of limit. Minimum passing margin is -6.46dB at 2390.00MHz
15.247(e)	Power Spectral Density Limit: max. 8dBm	PASS	Meet the requirement of limit.
15.247(d)	Band Edge Measurement Limit: 20dB less than the peak value of fundamental frequency	PASS	Meet the requirement of limit.

2.1 MEASUREMENT UNCERTAINTY

Where relevant, the following measurement uncertainty levels have been estimated for tests performed on the EUT as specified in CISPR 16-4:

Measurement	Frequency	Uncertainty
Conducted emissions	9kHz~30MHz	2.44 dB
	30MHz ~ 200MHz	3.63 dB
Radiated emissions	200MHz ~ 1000MHz	3.65 dB
	1GHz ~ 18GHz	2.20 dB
	18GHz ~ 40GHz	1.88 dB



3. GENERAL INFORMATION

3.1 GENERAL DESCRIPTION OF EUT

EUT	Wireless 802.11g Cardbus Card
MODEL NO.	WCB-210A
POWER SUPPLY	3.3Vdc from host equipment
MODULATION TYPE	CCK, DQPSK, DBPSK for DSSS 64QAM, 16QAM, QPSK, BPSK for OFDM
RADIO TECHNOLOGY	DSSS, OFDM
TRANSFER RATE	802.11b: 11/5.5/2/1Mbps 802.11g: 54/48/36/24/18/12/9/6Mbps
FREQUENCY RANGE	2412MHz ~ 2462MHz
NUMBER OF CHANNEL	11
OUTPUT POWER	66.988mW
ANTENNA TYPE	Printed PCB antenna with 3.09dBi gain
DATA CABLE	NA
I/O PORTS	NA
ASSOCIATED DEVICES	NA

NOTE:

1. The EUT complies with IEEE 802.11g standards and backwards compatible with IEEE 802.11b products.
2. The EUT operates in the 2.4GHz frequency spectrum with throughput of up to 54Mbps.
3. The above EUT information was declared by manufacturer and for more detailed features description, please refer to the manufacturer's specifications or User's Manual.

3.1.1 DESCRIPTION OF EUT DIFFERENCE

1. This report is prepared for FCC Class II permissive change. The difference compared with the original design is changing the antenna gain and adding a new cover.
2. The difference of EUT structure is listed as below:

Item	Original Sample	New Sample
Antenna	0dBi printed antenna	3.09dBi printed antenna
cover	One cover	New cover (refer to internal photos)

3.2 DESCRIPTION OF TEST MODES

Eleven channels are provided to this EUT.

Channel	Frequency	Channel	Frequency
1	2412 MHz	7	2442 MHz
2	2417 MHz	8	2447 MHz
3	2422 MHz	9	2452 MHz
4	2427 MHz	10	2457 MHz
5	2432 MHz	11	2462 MHz
6	2437 MHz		

3.2.1 CONFIGURATION OF SYSTEM UNDER TEST

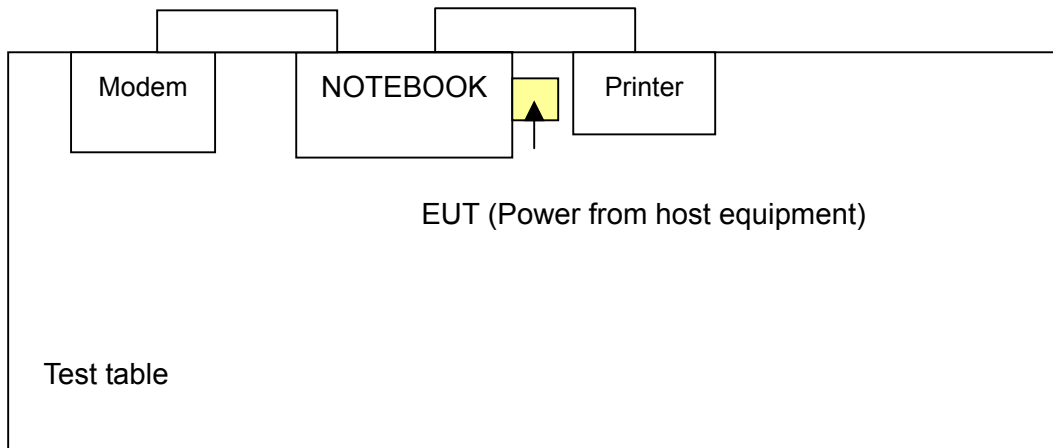



3.2.2 TEST MODE APPLICABILITY AND TESTED CHANNEL DETAIL:

EUT configure mode	Applicable to				Description
	PLC	RE<1G	RE≥1G	APCM	
-	√	√	√	√	NA

Where PLC: Power Line Conducted Emission RE<1G RE: Radiated Emission below 1GHz
 RE≥1G: Radiated Emission above 1GHz APCM: Antenna Port Conducted Measurement

Power Line Conducted Emission Test:

- Pre-Scan has been conducted to determine the worst-case mode from all possible combinations between available modulations, data rates and antenna ports (if EUT with antenna diversity architecture).
- Following channel(s) was (were) selected for the final test as listed below.

Mode	Available Channel	Tested Channel	Modulation Technology	Modulation Type	Data Rate (Mbps)
802.11g	1 to 11	1, 6, 11	OFDM	BPSK	6

Radiated Emission Test (Below 1 GHz):

- Pre-Scan has been conducted to determine the worst-case mode from all possible combinations between available modulations, data rates and antenna ports (if EUT with antenna diversity architecture).
- Following channel(s) was (were) selected for the final test as listed below.

Mode	Available Channel	Tested Channel	Modulation Technology	Modulation Type	Data Rate (Mbps)
802.11g	1 to 11	1	OFDM	BPSK	6

Radiated Emission Test (Above 1 GHz):

- Pre-Scan has been conducted to determine the worst-case mode from all possible combinations between available modulations, data rates and antenna ports (if EUT with antenna diversity architecture).
- Following channel(s) was (were) selected for the final test as listed below.

Mode	Available Channel	Tested Channel	Modulation Technology	Modulation Type	Data Rate (Mbps)
802.11b	1 to 11	1, 6, 11	DSSS	CCK	11
802.11g	1 to 11	1, 6, 11	OFDM	BPSK	6



Bandedge Measurement:

- Pre-Scan has been conducted to determine the worst-case mode from all possible combinations between available modulations, data rates and antenna ports (if EUT with antenna diversity architecture).
- Following channel(s) was (were) selected for the final test as listed below.

Mode	Available Channel	Tested Channel	Modulation Technology	Modulation Type	Data Rate (Mbps)
802.11b	1 to 11	1, 11	DSSS	CCK	11
802.11g	1 to 11	1, 11	OFDM	BPSK	6



3.3 GENERAL DESCRIPTION OF APPLIED STANDARDS

The EUT is a Wireless 802.11g Cardbus Card. According to the specifications of the manufacturer, it must comply with the requirements of the following standards:

FCC Part 15, Subpart C. (15.247)

ANSI C63.4- 2003

All test items have been performed and recorded as per the above standards.

NOTE: The EUT is also considered as a kind of computer peripheral, because the connection to computer is necessary for typical use. It has been verified to comply with the requirements of FCC Part 15, Subpart B, Class B (DoC). The test report has been issued separately.

3.4 DESCRIPTION OF SUPPORT UNITS

The EUT has been tested as an independent unit together with other necessary accessories or support units. The following support units or accessories were used to form a representative test configuration during the tests.

NO.	PRODUCT	BRAND	MODEL NO.	SERIAL NO.	FCC ID
1	NOTEBOOK COMPUTER	DELL	PP05L	20838027664	E2K24CLNS
2	MODEM	ACEEX	1414V/3	0401008260	IFAXDM1414
3	PRINTER	EPSON	LQ-300+	DCGY054146	FCC DoC Approved

NO.	SIGNAL CABLE DESCRIPTION OF THE ABOVE SUPPORT UNITS
1	NA
2	1.2m shielded cable without core.
3	1.2m shielded cable without core.

NOTE: All power cords of the above support units are non shielded (1.8m).

4. TEST TYPES AND RESULTS

4.1 CONDUCTED EMISSION MEASUREMENT

4.1.1 LIMITS OF CONDUCTED EMISSION MEASUREMENT

FREQUENCY OF EMISSION (MHz)	CONDUCTED LIMIT (dB μ V)	
	Quasi-peak	Average
0.15-0.5	66 to 56	56 to 46
0.5-5	56	46
5-30	60	50

- NOTE:**
1. The lower limit shall apply at the transition frequencies.
 2. The limit decreases in line with the logarithm of the frequency in the range of 0.15 to 0.50 MHz.
 3. All emanations from a class A/B digital device or system, including any network of conductors and apparatus connected thereto, shall not exceed the level of field strengths specified above.

4.1.2 TEST INSTRUMENTS

DESCRIPTION & MANUFACTURER	MODEL NO.	SERIAL NO.	CALIBRATED UNTIL
Test Receiver ROHDE & SCHWARZ	ESCS30	100288	Nov. 06, 2005
RF signal cable Woken	5D-FB	Cable-HyC02-01	Jan. 09, 2006
LISN ROHDE & SCHWARZ	ESH2-Z5	100100	Jan. 20, 2006
LISN ROHDE & SCHWARZ	ESH3-Z5	100311	Jan. 20, 2006
Software ADT	ADT_Cond_V3	NA	NA

- NOTE:**
1. The calibration interval of the above test instruments is 12 months and the calibrations are traceable to NML/ROC and NIST/USA.
 2. The test was performed in HwaYa Shielded Room 3.
 3. The VCCI Site Registration No. is C-2047.



4.1.3 TEST PROCEDURES

- a. The EUT was placed 0.4 meters from the conducting wall of the shielded room with EUT being connected to the power mains through a line impedance stabilization network (LISN). Other support units were connected to the power mains through another LISN. The two LISNs provide 50 ohm/ 50uH of coupling impedance for the measuring instrument.
- b. Both lines of the power mains connected to the EUT were checked for maximum conducted interference.
- c. The frequency range from 150kHz to 30MHz was searched. Emission levels under (Limit - 20dB) was not recorded.

4.1.4 DEVIATION FROM TEST STANDARD

No deviation

4.1.5 TEST SETUP

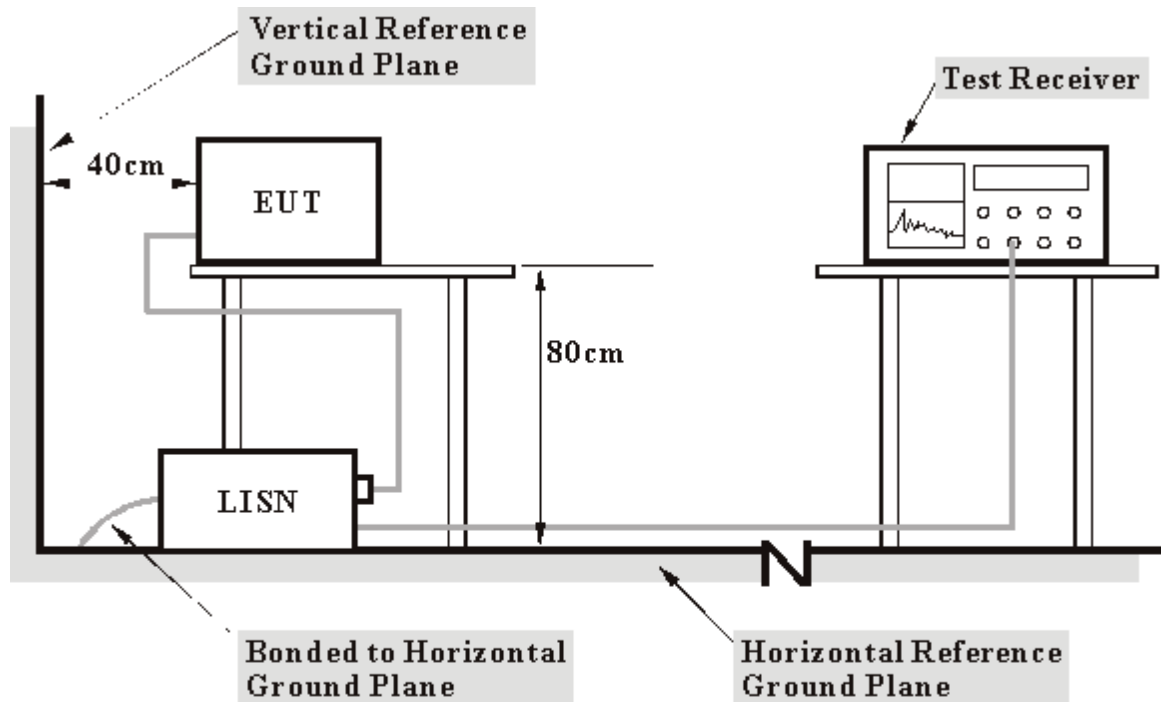

- Note:**
1. Support units were connected to second LISN.
 2. Both of LISNs (AMN) 80 cm from EUT and at the least 80 cm from other units and other metal planes support units.

For the actual test configuration, please refer to the related item – Photographs of the Test Configuration.

4.1.6 EUT OPERATING CONDITIONS

- a. Connected the EUT to a notebook system placed on a testing table.
- b. The notebook system ran a test program (provided by manufacturer) to enable EUT under transmission/receiving condition continuously at specific channel frequency.
- c. The notebook system sent "H" messages to its screen.
- d. The notebook system sent "H" messages to its modem.
- e. The notebook system sent "H" messages to printer and the printer printed them on paper.
- f. Item c ~ e were repeated.



4.1.7 TEST RESULTS

Conducted Worst-Case Data

EUT	Wireless 802.11g Cardbus Card	MODEL	WCB-210A
CHANNEL	Channel 1	6dB BANDWIDTH	9 kHz
MODULATION TYPE	BPSK	TRANSFER RATE	6Mbps
INPUT POWER (SYSTEM)	120Vac, 60 Hz	PHASE	Line 1
ENVIRONMENTAL CONDITIONS	22deg. C, 63%RH, 991hPa	TESTED BY	Brad Wu

No	Freq. [MHz]	Corr. Factor (dB)	Reading Value [dB (uV)]		Emission Level [dB (uV)]		Limit [dB (uV)]		Margin (dB)	
			Q.P.	AV.	Q.P.	AV.	Q.P.	AV.	Q.P.	AV.
			1	0.185	0.10	36.12	-	36.22	-	64.25
2	0.232	0.10	41.32	-	41.42	-	62.38	52.38	-20.96	-
3	0.345	0.10	31.24	-	31.34	-	59.07	49.07	-27.73	-
4	2.199	0.20	30.59	-	30.79	-	56.00	46.00	-25.21	-
5	3.758	0.20	27.69	-	27.89	-	56.00	46.00	-28.11	-
6	10.801	0.32	34.25	-	34.57	-	60.00	50.00	-25.43	-

- REMARKS:**
1. Q.P. and AV. are abbreviations of quasi-peak and average individually.
 2. "-": The Quasi-peak reading value also meets average limit and measurement with the average detector is unnecessary.
 3. The emission levels of other frequencies were very low against the limit.
 4. Margin value = Emission level - Limit value
 5. Correction factor = Insertion loss + Cable loss
 6. Emission Level = Correction Factor + Reading Value.

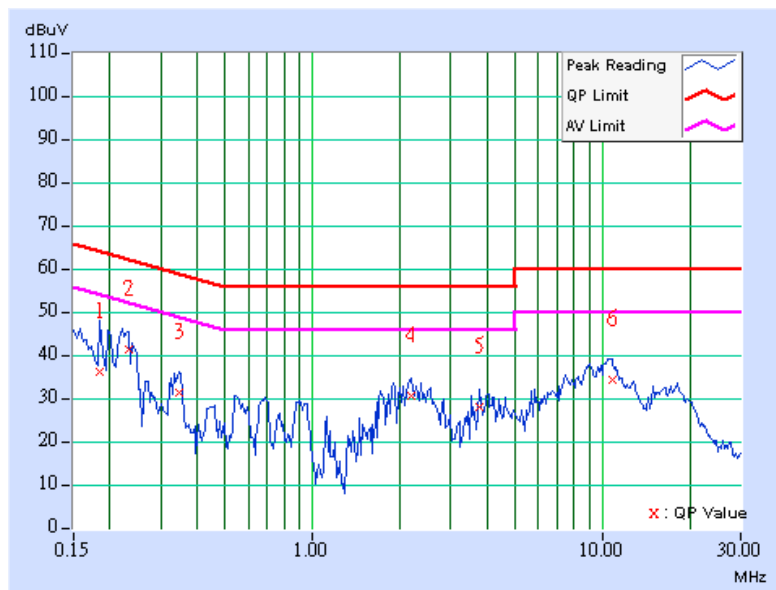



EUT	Wireless 802.11g Cardbus Card	MODEL	WCB-210A
CHANNEL	Channel 1	6dB BANDWIDTH	9 kHz
MODULATION TYPE	BPSK	TRANSFER RATE	6Mbps
INPUT POWER (SYSTEM)	120Vac, 60 Hz	PHASE	Line 2
ENVIRONMENTAL CONDITIONS	22deg. C, 63%RH, 991hPa	TESTED BY	Brad Wu

No	Freq. [MHz]	Corr. Factor (dB)	Reading Value		Emission Level		Limit		Margin	
			[dB (uV)]		[dB (uV)]		[dB (uV)]		(dB)	
			Q.P.	AV.	Q.P.	AV.	Q.P.	AV.	Q.P.	AV.
1	0.181	0.10	36.79	-	36.89	-	64.43	54.43	-27.54	-
2	0.220	0.10	44.62	30.64	44.72	30.74	62.81	52.81	-18.09	-22.07
3	0.685	0.15	29.54	-	29.69	-	56.00	46.00	-26.31	-
4	1.941	0.20	30.76	-	30.96	-	56.00	46.00	-25.04	-
5	2.375	0.20	29.12	-	29.32	-	56.00	46.00	-26.68	-
6	10.160	0.40	34.65	-	35.05	-	60.00	50.00	-24.95	-

- REMARKS:**
1. Q.P. and AV. are abbreviations of quasi-peak and average individually.
 2. "-": The Quasi-peak reading value also meets average limit and measurement with the average detector is unnecessary.
 3. The emission levels of other frequencies were very low against the limit.
 4. Margin value = Emission level - Limit value
 5. Correction factor = Insertion loss + Cable loss
 6. Emission Level = Correction Factor + Reading Value.

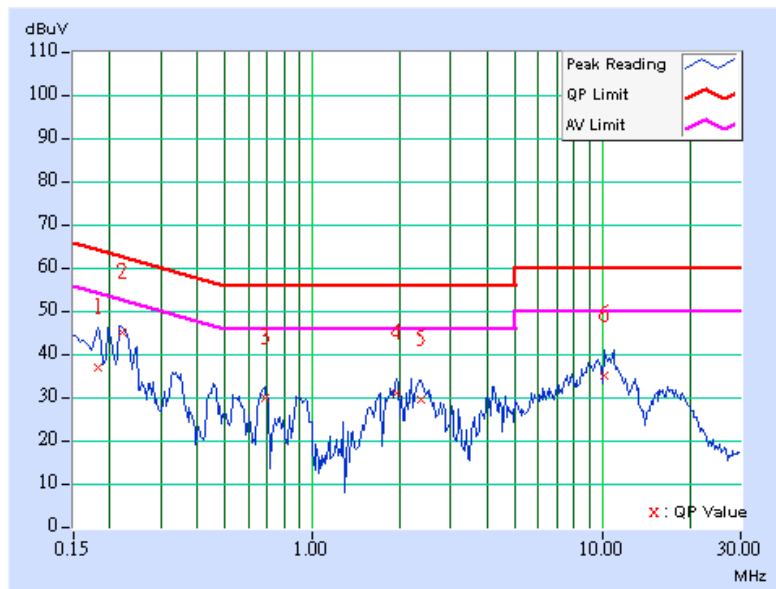



EUT	Wireless 802.11g Cardbus Card	MODEL	WCB-210A
CHANNEL	Channel 6	6dB BANDWIDTH	9 kHz
MODULATION TYPE	BPSK	TRANSFER RATE	6Mbps
INPUT POWER (SYSTEM)	120Vac, 60 Hz	PHASE	Line 1
ENVIRONMENTAL CONDITIONS	22deg. C, 63%RH, 991hPa	TESTED BY	Brad Wu

No	Freq. [MHz]	Corr. Factor (dB)	Reading Value [dB (uV)]		Emission Level [dB (uV)]		Limit [dB (uV)]		Margin (dB)	
			Q.P.	AV.	Q.P.	AV.	Q.P.	AV.	Q.P.	AV.
			1	0.189	0.10	36.71	-	36.81	-	64.08
2	0.345	0.10	31.30	-	31.40	-	59.07	49.07	-27.67	-
3	0.689	0.15	27.82	-	27.97	-	56.00	46.00	-28.03	-
4	2.180	0.20	31.17	-	31.37	-	56.00	46.00	-24.63	-
5	3.777	0.20	27.52	-	27.72	-	56.00	46.00	-28.28	-
6	10.090	0.30	33.82	-	34.12	-	60.00	50.00	-25.88	-

- REMARKS:**
1. Q.P. and AV. are abbreviations of quasi-peak and average individually.
 2. "-": The Quasi-peak reading value also meets average limit and measurement with the average detector is unnecessary.
 3. The emission levels of other frequencies were very low against the limit.
 4. Margin value = Emission level - Limit value
 5. Correction factor = Insertion loss + Cable loss
 6. Emission Level = Correction Factor + Reading Value.

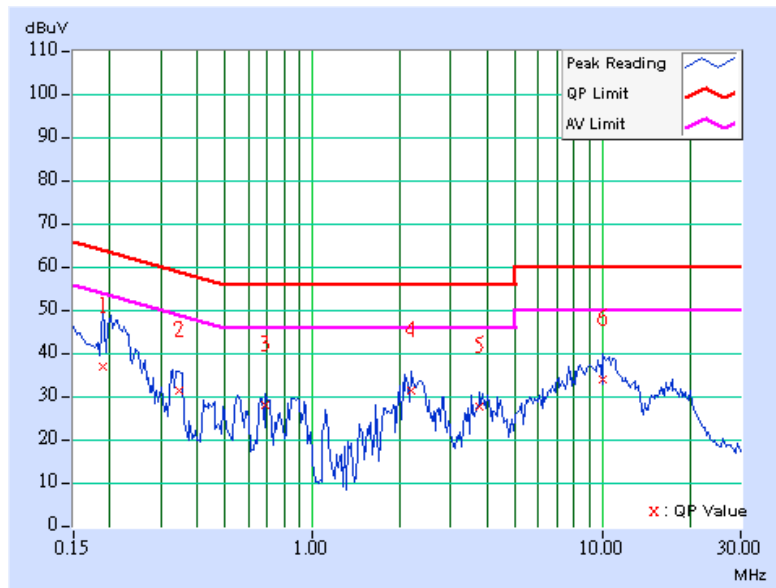



EUT	Wireless 802.11g Cardbus Card	MODEL	WCB-210A
CHANNEL	Channel 6	6dB BANDWIDTH	9 kHz
MODULATION TYPE	BPSK	TRANSFER RATE	6Mbps
INPUT POWER (SYSTEM)	120Vac, 60 Hz	PHASE	Line 2
ENVIRONMENTAL CONDITIONS	22deg. C, 63%RH, 991hPa	TESTED BY	Brad Wu

No	Freq. [MHz]	Corr. Factor (dB)	Reading Value [dB (uV)]		Emission Level [dB (uV)]		Limit [dB (uV)]		Margin (dB)	
			Q.P.	AV.	Q.P.	AV.	Q.P.	AV.	Q.P.	AV.
			1	0.166	0.10	41.13	-	41.23	-	65.18
2	0.216	0.10	43.74	28.18	43.84	28.28	62.96	52.96	-19.12	-24.68
3	0.341	0.10	32.79	-	32.89	-	59.17	49.17	-26.28	-
4	2.148	0.20	30.89	-	31.09	-	56.00	46.00	-24.91	-
5	10.531	0.41	34.98	-	35.39	-	60.00	50.00	-24.61	-
6	17.789	0.67	26.79	-	27.46	-	60.00	50.00	-32.54	-

- REMARKS:**
1. Q.P. and AV. are abbreviations of quasi-peak and average individually.
 2. "-": The Quasi-peak reading value also meets average limit and measurement with the average detector is unnecessary.
 3. The emission levels of other frequencies were very low against the limit.
 4. Margin value = Emission level - Limit value
 5. Correction factor = Insertion loss + Cable loss
 6. Emission Level = Correction Factor + Reading Value.

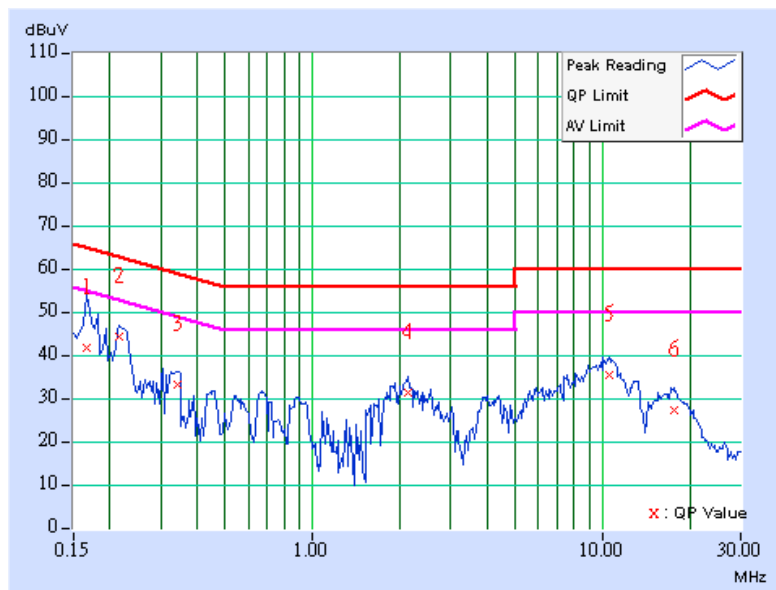



EUT	Wireless 802.11g Cardbus Card	MODEL	WCB-210A
CHANNEL	Channel 11	6dB BANDWIDTH	9 kHz
MODULATION TYPE	BPSK	TRANSFER RATE	6Mbps
INPUT POWER (SYSTEM)	120Vac, 60 Hz	PHASE	Line 1
ENVIRONMENTAL CONDITIONS	22deg. C, 63%RH, 991hPa	TESTED BY	Brad Wu

No	Freq. [MHz]	Corr. Factor (dB)	Reading Value [dB (uV)]		Emission Level [dB (uV)]		Limit [dB (uV)]		Margin (dB)	
			Q.P.	AV.	Q.P.	AV.	Q.P.	AV.	Q.P.	AV.
			1	0.150	0.10	41.45	-	41.55	-	66.00
2	0.220	0.10	43.48	28.18	43.58	28.28	62.81	52.81	-19.23	-24.53
3	0.685	0.15	27.39	-	27.54	-	56.00	46.00	-28.46	-
4	2.320	0.20	29.95	-	30.15	-	56.00	46.00	-25.85	-
5	4.152	0.20	27.28	-	27.48	-	56.00	46.00	-28.52	-
6	10.770	0.32	34.33	-	34.65	-	60.00	50.00	-25.35	-

- REMARKS:**
1. Q.P. and AV. are abbreviations of quasi-peak and average individually.
 2. "-": The Quasi-peak reading value also meets average limit and measurement with the average detector is unnecessary.
 3. The emission levels of other frequencies were very low against the limit.
 4. Margin value = Emission level - Limit value
 5. Correction factor = Insertion loss + Cable loss
 6. Emission Level = Correction Factor + Reading Value.

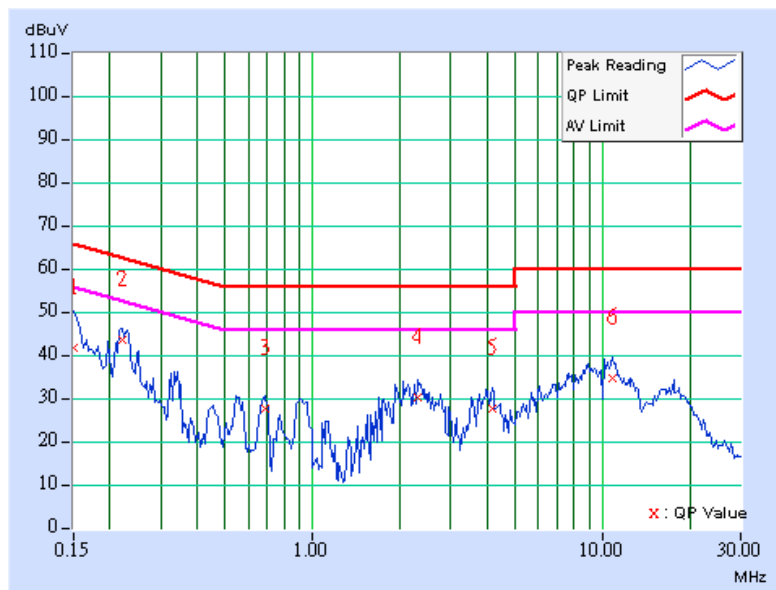



EUT	Wireless 802.11g Cardbus Card	MODEL	WCB-210A
CHANNEL	Channel 11	6dB BANDWIDTH	9 kHz
MODULATION TYPE	BPSK	TRANSFER RATE	6Mbps
INPUT POWER (SYSTEM)	120Vac, 60 Hz	PHASE	Line 2
ENVIRONMENTAL CONDITIONS	22deg. C, 63%RH, 991hPa	TESTED BY	Brad Wu

No	Freq. [MHz]	Corr. Factor (dB)	Reading Value [dB (uV)]		Emission Level [dB (uV)]		Limit [dB (uV)]		Margin (dB)	
			Q.P.	AV.	Q.P.	AV.	Q.P.	AV.	Q.P.	AV.
			1	0.185	0.10	36.06	-	36.16	-	64.25
2	0.220	0.10	44.66	30.25	44.76	30.35	62.81	52.81	-18.05	-22.46
3	0.685	0.15	29.36	-	29.51	-	56.00	46.00	-26.49	-
4	2.109	0.20	30.66	-	30.86	-	56.00	46.00	-25.14	-
5	4.027	0.20	26.75	-	26.95	-	56.00	46.00	-29.05	-
6	10.281	0.41	34.25	-	34.66	-	60.00	50.00	-25.34	-

- REMARKS:**
1. Q.P. and AV. are abbreviations of quasi-peak and average individually.
 2. "-": The Quasi-peak reading value also meets average limit and measurement with the average detector is unnecessary.
 3. The emission levels of other frequencies were very low against the limit.
 4. Margin value = Emission level - Limit value
 5. Correction factor = Insertion loss + Cable loss
 6. Emission Level = Correction Factor + Reading Value.

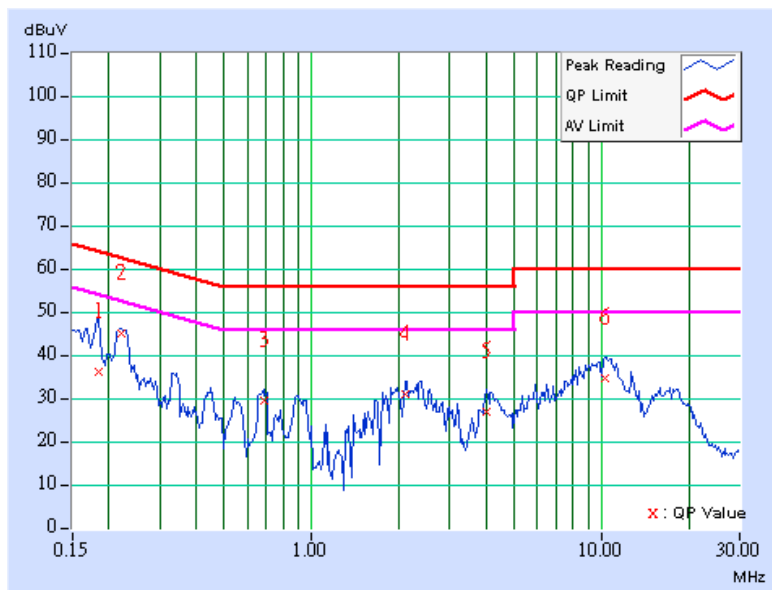



4.2 RADIATED EMISSION MEASUREMENT

4.2.1 LIMITS OF RADIATED EMISSION MEASUREMENT

Emissions radiated outside of the specified bands, shall be according to the general radiated limits in 15.209 as following:

Frequencies (MHz)	Field strength (microvolts/meter)	Measurement distance (meters)
0.009-0.490	2400/F(kHz)	300
0.490-1.705	24000/F(kHz)	30
1.705-30.0	30	30
30-88	100	3
88-216	150	3
216-960	200	3
Above 960	500	3

NOTE:

1. The lower limit shall apply at the transition frequencies.
2. Emission level (dBuV/m) = 20 log Emission level (uV/m).
3. As shown in 15.35(b), for frequencies above 1000MHz, the field strength limits are based on average detector, however, the peak field strength of any emission shall not exceed the maximum permitted average limits, specified above by more than 20dB under any condition of modulation.



4.2.2 TEST INSTRUMENTS

DESCRIPTION & MANUFACTURER	MODEL NO.	SERIAL NO.	CALIBRATED UNTIL
Test Receiver ROHDE & SCHWARZ	ES17	100033	Jun. 08, 2005
Spectrum Analyzer ROHDE & SCHWARZ	FSP40	100040	Jun. 03, 2005
BILOG Antenna SCHWARZBECK	VULB9168	9168-160	Jun. 01, 2005
HORN Antenna SCHWARZBECK	9120D	9120D-408	Jan. 17, 2006
HORN Antenna SCHWARZBECK	BBHA 9170	BBHA9170243	Jan. 23, 2006
Preamplifier Agilent	8447D	2944A10633	Nov. 09, 2005
Preamplifier Agilent	8449B	3008A01964	Nov. 06, 2005
RF signal cable HUBER+SUHNNER	SUCOFLEX 104	218183/4	Jan. 26, 2006
RF signal cable HUBER+SUHNNER	SUCOFLEX 104	218195/4	Jan. 26, 2006
Software ADT.	ADT_Radiated_V5.14	NA	NA
Antenna Tower inn-co GmbH	MA 4000	013303	NA
Antenna Tower Controller inn-co GmbH	CO2000	017303	NA
Turn Table ADT.	TT100.	TT93021703	NA
Turn Table Controller ADT.	SC100.	SC93021703	NA

- NOTE:** 1. The calibration interval of the above test instruments is 12 months and the calibrations are traceable to NML/ROC and NIST/USA.
2. The test was performed in HwaYa Chamber 2.
3. The horn antenna and HP preamplifier (model: 8449B) are used only for the measurement of emission frequency above 1GHz if tested.
4. The VCCI Site Registration No. is R-237.
5. The IC Site Registration No. is IC4924-3.

4.2.3 TEST PROCEDURES

- a. The EUT was placed on the top of a rotating table 0.8 meters above the ground at a 3 meter semi-anechoic chamber. The table was rotated 360 degrees to determine the position of the highest radiation.
- b. The EUT was set 3 meters away from the interference-receiving antenna, which was mounted on the top of a variable-height antenna tower.
- c. The antenna is a broadband antenna, and its height is varied from one meter to four meters above the ground to determine the maximum value of the field strength. Both horizontal and vertical polarizations of the antenna are set to make the measurement.
- d. For each suspected emission, the EUT was arranged to its worst case and then the antenna was tuned to heights from 1 meter to 4 meters and the rotatable table was turned from 0 degrees to 360 degrees to find the maximum reading.
- e. The test-receiver system was set to Peak Detect Function and Specified Bandwidth with Maximum Hold Mode.
- f. If the emission level of the EUT in peak mode was 10 dB lower than the limit specified, then testing could be stopped and the peak values of the EUT would be reported. Otherwise the emissions that did not have 10 dB margin would be re-tested one by one using the quasi-peak method or average method as specified and then reported in Data sheet peak mode and QP mode.

NOTE:

1. The resolution bandwidth and video bandwidth of test receiver/spectrum analyzer is 120kHz for Quasi-peak detection at frequency below 1GHz.
2. The resolution bandwidth and video bandwidth of test receiver/spectrum analyzer is 1 MHz for Peak detection (PK) at frequency above 1GHz.
3. The resolution bandwidth of test receiver/spectrum analyzer is 1 MHz and the video bandwidth is 10 Hz for Average detection (AV) at frequency above 1GHz.

4.2.4 DEVIATION FROM TEST STANDARD

No deviation

4.2.5 TEST SETUP

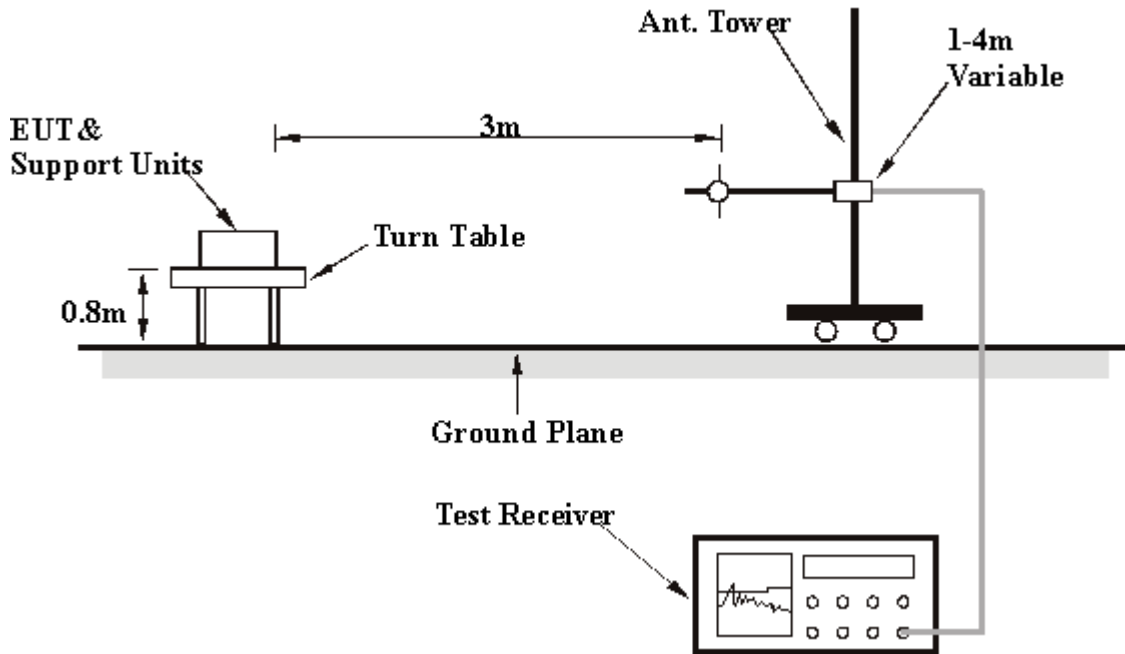

For the actual test configuration, please refer to the related item – Photographs of the Test Configuration.

4.2.6 EUT OPERATING CONDITIONS

Same as 4.1.6

4.2.7 TEST RESULTS

Below 1GHz Worst-Case Data

EUT	Wireless 802.11g Cardbus Card	MODEL	WCB-210A
CHANNEL	Channel 1	FREQUENCY RANGE	Below 1000MHz
MODULATION TYPE	BPSK	TRANSFER RATE	6Mbps
INPUT POWER (SYSTEM)	120Vac, 60 Hz	DETECTOR FUNCTION	Quasi-Peak
ENVIRONMENTAL CONDITIONS	22deg. C, 68%RH, 991hPa	TESTED BY	Morgan Chen

ANTENNA POLARITY & TEST DISTANCE: HORIZONTAL AT 3 M

No.	Freq. (MHz)	Emission Level (dBuV/m)	Limit (dBuV/m)	Margin (dB)	Antenna Height (m)	Table Angle (Degree)	Raw Value (dBuV)	Correction Factor (dB/m)
1	115.53	32.96 QP	43.50	-10.54	1.25 H	247	20.06	12.91
2	199.12	32.95 QP	43.50	-10.55	1.00 H	34	21.02	11.93
3	352.69	29.33 QP	46.00	-16.67	1.00 H	157	13.11	16.22
4	399.34	35.97 QP	46.00	-10.03	1.00 H	343	18.75	17.22
5	453.77	27.73 QP	46.00	-18.27	1.25 H	316	9.03	18.69
6	665.65	31.63 QP	46.00	-14.37	1.25 H	10	9.14	22.49

ANTENNA POLARITY & TEST DISTANCE: VERTICAL AT 3 M

No.	Freq. (MHz)	Emission Level (dBuV/m)	Limit (dBuV/m)	Margin (dB)	Antenna Height (m)	Table Angle (Degree)	Raw Value (dBuV)	Correction Factor (dB/m)
1	133.03	28.54 QP	43.50	-14.96	1.25 V	340	14.27	14.27
2	199.12	29.60 QP	43.50	-13.90	1.75 V	307	17.67	11.93
3	220.50	26.99 QP	46.00	-19.01	1.00 V	226	14.67	12.32
4	399.34	39.42 QP	46.00	-6.58	1.00 V	16	22.19	17.22
5	455.71	30.60 QP	46.00	-15.40	1.25 V	325	11.88	18.72
6	667.60	30.81 QP	46.00	-15.19	1.50 V	7	8.30	22.51

- REMARKS:**
1. Emission level(dBuV/m)=Raw Value(dBuV) + Correction Factor(dB/m)
 2. Correction Factor(dB/m) = Antenna Factor (dB/m) + Cable Factor (dB)
 3. The other emission levels were very low against the limit.
 4. Margin value = Emission level – Limit value.

**802.11b DSSS modulation**

EUT	Wireless 802.11g Cardbus Card	MODEL	WCB-210A
CHANNEL	Channel 1	FREQUENCY RANGE	1 ~ 25GHz
MODULATION TYPE	CCK	TRANSFER RATE	11Mbps
INPUT POWER (SYSTEM)	120Vac, 60 Hz	DETECTOR FUNCTION	Peak(PK) Average (AV)
ENVIRONMENTAL CONDITIONS	22deg. C, 68%RH, 991hPa	TESTED BY	Morgan Chen

ANTENNA POLARITY & TEST DISTANCE: HORIZONTAL AT 3 M

No.	Freq. (MHz)	Emission Level (dBuV/m)	Limit (dBuV/m)	Margin (dB)	Antenna Height (m)	Table Angle (Degree)	Raw Value (dBuV)	Correction Factor (dB/m)
1	1608.00	42.58 PK	74.00	-31.42	1.10 H	145	13.83	28.75
2	2390.00	55.48 PK	74.00	-18.52	1.09 H	150	24.16	31.32
2	2390.00	47.54 AV	54.00	-6.46	1.09 H	150	16.22	31.32
3	*2412.00	108.88 PK			1.34 H	76	77.47	31.41
3	*2412.00	100.94 AV			1.34 H	76	69.53	31.41
4	3216.00	46.20 PK	74.00	-27.80	1.14 H	18	13.08	33.12
4	3216.00	37.06 AV	54.00	-16.94	1.14 H	18	3.94	33.12
5	4824.00	52.88 PK	74.00	-21.12	1.09 H	150	16.07	36.81
5	4824.00	45.66 AV	54.00	-8.34	1.09 H	150	8.85	36.81

ANTENNA POLARITY & TEST DISTANCE: VERTICAL AT 3 M

No.	Freq. (MHz)	Emission Level (dBuV/m)	Limit (dBuV/m)	Margin (dB)	Antenna Height (m)	Table Angle (Degree)	Raw Value (dBuV)	Correction Factor (dB/m)
1	1608.00	41.58 PK	74.00	-32.42	1.19 V	268	12.83	28.75
2	2390.00	46.73 PK	74.00	-27.27	1.73 V	220	15.41	31.32
3	*2412.00	100.13 PK			1.73 V	220	68.72	31.41
3	*2412.00	93.02 AV			1.73 V	220	61.61	31.41
4	3216.00	45.13 PK	74.00	-28.87	1.16 V	265	12.01	33.12
5	4824.00	48.97 PK	74.00	-25.03	1.18 V	20	12.16	36.81

- REMARKS:**
1. Emission level(dBuV/m)=Raw Value(dBuV) + Correction Factor(dB/m)
 2. Correction Factor(dB/m) = Antenna Factor (dB/m) + Cable Factor (dB)
 3. The other emission levels were very low against the limit.
 4. Margin value = Emission level – Limit value.
 5. “ * “ : Fundamental frequency



EUT	Wireless 802.11g Cardbus Card	MODEL	WCB-210A
CHANNEL	Channel 6	FREQUENCY RANGE	1 ~ 25GHz
MODULATION TYPE	CCK	TRANSFER RATE	11Mbps
INPUT POWER (SYSTEM)	120Vac, 60 Hz	DETECTOR FUNCTION	Peak(PK) Average (AV)
ENVIRONMENTAL CONDITIONS	22deg. C, 68%RH, 991hPa	TESTED BY	Morgan Chen

ANTENNA POLARITY & TEST DISTANCE: HORIZONTAL AT 3 M

No.	Freq. (MHz)	Emission Level (dBuV/m)	Limit (dBuV/m)	Margin (dB)	Antenna Height (m)	Table Angle (Degree)	Raw Value (dBuV)	Correction Factor (dB/m)
1	1624.00	43.32 PK	74.00	-30.68	1.11 H	132	14.52	28.80
2	*2437.00	108.52 PK			1.02 H	48	77.00	31.52
2	*2437.00	100.12 AV			1.02 H	48	68.60	31.52
3	3248.00	46.35 PK	74.00	-27.65	1.10 H	25	13.20	33.15
4	4874.00	49.47 PK	74.00	-24.53	1.17 H	62	12.51	36.95
4	4874.00	42.13 AV	54.00	-11.87	1.17 H	62	5.17	36.95

ANTENNA POLARITY & TEST DISTANCE: VERTICAL AT 3 M

No.	Freq. (MHz)	Emission Level (dBuV/m)	Limit (dBuV/m)	Margin (dB)	Antenna Height (m)	Table Angle (Degree)	Raw Value (dBuV)	Correction Factor (dB/m)
1	1624.00	42.65 PK	74.00	-31.35	1.19 V	265	13.85	28.80
2	*2437.00	98.87 PK			1.75 V	250	67.35	31.52
2	*2437.00	91.12 AV			1.75 V	250	59.60	31.52
3	3248.00	45.25 PK	74.00	-28.75	1.19 V	258	12.10	33.15
4	4874.00	46.85 PK	74.00	-27.15	1.17 V	35	9.90	36.95

- REMARKS:**
1. Emission level(dBuV/m)=Raw Value(dBuV) + Correction Factor(dB/m)
 2. Correction Factor(dB/m) = Antenna Factor (dB/m) + Cable Factor (dB)
 3. The other emission levels were very low against the limit.
 4. Margin value = Emission level – Limit value.
 5. “ * “ : Fundamental frequency



EUT	Wireless 802.11g Cardbus Card	MODEL	WCB-210A
CHANNEL	Channel 11	FREQUENCY RANGE	1 ~ 25GHz
MODULATION TYPE	CCK	TRANSFER RATE	11Mbps
INPUT POWER (SYSTEM)	120Vac, 60 Hz	DETECTOR FUNCTION	Peak(PK) Average (AV)
ENVIRONMENTAL CONDITIONS	22deg. C, 68%RH, 99hPa	TESTED BY	Morgan Chen

ANTENNA POLARITY & TEST DISTANCE: HORIZONTAL AT 3 M

No.	Freq. (MHz)	Emission Level (dBuV/m)	Limit (dBuV/m)	Margin (dB)	Antenna Height (m)	Table Angle (Degree)	Raw Value (dBuV)	Correction Factor (dB/m)
1	1641.00	42.04 PK	74.00	-31.96	1.01 H	135	13.19	28.84
2	*2462.00	108.21 PK			1.05 H	55	76.58	31.63
2	*2462.00	100.25 AV			1.05 H	55	68.62	31.63
3	2483.50	44.62 PK	74.00	-29.38	1.02 H	35	12.90	31.72
4	3282.00	46.85 PK	74.00	-27.15	1.09 H	65	13.67	33.18
5	4924.00	49.89 PK	74.00	-24.11	1.18 H	72	12.79	37.10

ANTENNA POLARITY & TEST DISTANCE: VERTICAL AT 3 M

No.	Freq. (MHz)	Emission Level (dBuV/m)	Limit (dBuV/m)	Margin (dB)	Antenna Height (m)	Table Angle (Degree)	Raw Value (dBuV)	Correction Factor (dB/m)
1	1641.00	41.25 PK	74.00	-32.75	1.35 V	325	12.41	28.84
2	*2462.00	98.55 PK			1.65 V	251	66.92	31.63
2	*2462.00	91.06 AV			1.65 V	251	59.43	31.63
3	2483.50	39.05 PK	74.00	-34.95	1.65 V	251	7.33	31.72
4	3282.00	45.25 PK	74.00	-28.75	1.32 V	256	12.07	33.18
5	4924.00	47.55 PK	74.00	-26.45	1.22 V	49	10.45	37.10

- REMARKS:**
1. Emission level(dBuV/m)=Raw Value(dBuV) + Correction Factor(dB/m)
 2. Correction Factor(dB/m) = Antenna Factor (dB/m) + Cable Factor (dB)
 3. The other emission levels were very low against the limit.
 4. Margin value = Emission level – Limit value.
 5. “ * “ : Fundamental frequency



802.11g OFDM modulation

EUT	Wireless 802.11g Cardbus Card	MODEL	WCB-210A
CHANNEL	Channel 1	FREQUENCY RANGE	1 ~ 25GHz
MODULATION TYPE	BPSK	TRANSFER RATE	6Mbps
INPUT POWER (SYSTEM)	120Vac, 60 Hz	DETECTOR FUNCTION	Peak(PK) Average (AV)
ENVIRONMENTAL CONDITIONS	22deg. C, 64%RH, 991hPa	TESTED BY	Brad Wu

ANTENNA POLARITY & TEST DISTANCE: HORIZONTAL AT 3 M

No.	Freq. (MHz)	Emission Level (dBuV/m)	Limit (dBuV/m)	Margin (dB)	Antenna Height (m)	Table Angle (Degree)	Raw Value (dBuV)	Correction Factor (dB/m)
1	1608.00	41.85 PK	74.00	-32.15	1.20 H	52	12.49	29.36
1	1608.00	34.33 AV	54.00	-19.67	1.20 H	52	4.97	29.36
2	2390.00	56.79 PK	74.00	-17.21	1.34 H	91	24.92	31.87
2	2390.00	47.03 AV	54.00	-6.97	1.34 H	91	15.16	31.87
3	*2412.00	103.62 PK			1.34 H	91	71.66	31.96
3	*2412.00	93.86 AV			1.34 H	91	61.90	31.96
4	3216.00	46.63 PK	74.00	-27.37	1.29 H	10	12.66	33.96
4	3216.00	36.24 AV	54.00	-17.76	1.29 H	10	2.27	33.96
5	4824.00	49.01 PK	74.00	-24.99	1.23 H	245	11.18	37.83

ANTENNA POLARITY & TEST DISTANCE: VERTICAL AT 3 M

No.	Freq. (MHz)	Emission Level (dBuV/m)	Limit (dBuV/m)	Margin (dB)	Antenna Height (m)	Table Angle (Degree)	Raw Value (dBuV)	Correction Factor (dB/m)
1	1608.00	40.76 PK	74.00	-33.24	1.20 V	143	11.40	29.36
2	2390.00	49.56 PK	74.00	-24.44	1.18 V	236	17.69	31.87
3	*2412.00	96.39 PK			1.18 V	236	64.43	31.96
3	*2412.00	86.65 AV			1.18 V	236	54.69	31.96
4	3216.00	44.58 PK	74.00	-29.42	1.15 V	80	10.62	33.96
5	4824.00	48.56 PK	74.00	-25.44	1.03 V	142	10.73	37.83

- REMARKS:**
1. Emission level(dBuV/m)=Raw Value(dBuV) + Correction Factor(dB/m)
 2. Correction Factor(dB/m) = Antenna Factor (dB/m) + Cable Factor (dB)
 3. The other emission levels were very low against the limit.
 4. Margin value = Emission level – Limit value.
 5. “ * “ : Fundamental frequency



EUT	Wireless 802.11g Cardbus Card	MODEL	WCB-210A
CHANNEL	Channel 6	FREQUENCY RANGE	1 ~ 25GHz
MODULATION TYPE	BPSK	TRANSFER RATE	6Mbps
INPUT POWER (SYSTEM)	120Vac, 60 Hz	DETECTOR FUNCTION	Peak(PK) Average (AV)
ENVIRONMENTAL CONDITIONS	22deg. C, 64%RH, 991hPa	TESTED BY	Brad Wu

ANTENNA POLARITY & TEST DISTANCE: HORIZONTAL AT 3 M

No.	Freq. (MHz)	Emission Level (dBuV/m)	Limit (dBuV/m)	Margin (dB)	Antenna Height (m)	Table Angle (Degree)	Raw Value (dBuV)	Correction Factor (dB/m)
1	1624.00	41.96 PK	74.00	-32.04	1.10 H	135	12.56	29.40
2	*2437.00	104.17 PK			1.33 H	88	72.11	32.06
2	*2437.00	94.72 AV			1.33 H	88	62.66	32.06
3	3248.00	46.71 PK	74.00	-27.29	1.20 H	78	12.72	33.99
4	4874.00	49.18 PK	74.00	-24.82	1.22 H	187	11.20	37.98

ANTENNA POLARITY & TEST DISTANCE: VERTICAL AT 3 M

No.	Freq. (MHz)	Emission Level (dBuV/m)	Limit (dBuV/m)	Margin (dB)	Antenna Height (m)	Table Angle (Degree)	Raw Value (dBuV)	Correction Factor (dB/m)
1	1624.00	41.43 PK	74.00	-32.57	1.08 V	109	12.03	29.40
2	*2437.00	97.01 PK			1.05 V	254	64.95	32.06
2	*2437.00	86.79 AV			1.05 V	254	54.73	32.06
3	3248.00	44.91 PK	74.00	-29.09	1.04 V	113	10.92	33.99
4	4874.00	48.72 PK	74.00	-25.28	1.09 V	130	10.74	37.98

- REMARKS:**
1. Emission level(dBuV/m)=Raw Value(dBuV) + Correction Factor(dB/m)
 2. Correction Factor(dB/m) = Antenna Factor (dB/m) + Cable Factor (dB)
 3. The other emission levels were very low against the limit.
 4. Margin value = Emission level – Limit value.
 5. “ * “ : Fundamental frequency



EUT	Wireless 802.11g Cardbus Card	MODEL	WCB-210A
CHANNEL	Channel 11	FREQUENCY RANGE	1 ~ 25GHz
MODULATION TYPE	BPSK	TRANSFER RATE	6Mbps
INPUT POWER (SYSTEM)	120Vac, 60 Hz	DETECTOR FUNCTION	Peak(PK) Average (AV)
ENVIRONMENTAL CONDITIONS	22deg. C, 68%RH, 991hPa	TESTED BY	Brad Wu

ANTENNA POLARITY & TEST DISTANCE: HORIZONTAL AT 3 M

No.	Freq. (MHz)	Emission Level (dBuV/m)	Limit (dBuV/m)	Margin (dB)	Antenna Height (m)	Table Angle (Degree)	Raw Value (dBuV)	Correction Factor (dB/m)
1	1641.00	42.31 PK	74.00	-31.69	1.04 H	122	12.86	29.45
2	*2462.00	104.05 PK			1.29 H	89	71.89	32.16
2	*2462.00	94.12 AV			1.29 H	89	61.96	32.16
3	2483.50	51.95 PK	74.00	-22.05	1.29 H	89	19.71	32.24
3	2483.50	42.02 AV	54.00	-11.98	1.29 H	89	9.78	32.24
4	3282.00	47.21 PK	74.00	-26.79	1.21 H	149	13.19	34.02
5	4924.00	49.56 PK	74.00	-24.44	1.19 H	207	11.42	38.14

ANTENNA POLARITY & TEST DISTANCE: VERTICAL AT 3 M

No.	Freq. (MHz)	Emission Level (dBuV/m)	Limit (dBuV/m)	Margin (dB)	Antenna Height (m)	Table Angle (Degree)	Raw Value (dBuV)	Correction Factor (dB/m)
1	1641.00	41.09 PK	74.00	-32.91	1.03 V	214	11.64	29.45
2	*2462.00	95.51 PK			1.11 V	238	63.35	32.16
2	*2462.00	85.72 AV			1.11 V	238	53.56	32.16
3	2483.50	43.41 PK	74.00	-30.59	1.11 V	238	11.17	32.24
4	3282.00	45.26 PK	74.00	-28.74	1.07 V	94	11.24	34.02
5	4924.00	48.83 PK	74.00	-25.17	1.10 V	219	10.69	38.14

- REMARKS:**
1. Emission level(dBuV/m)=Raw Value(dBuV) + Correction Factor(dB/m)
 2. Correction Factor(dB/m) = Antenna Factor (dB/m) + Cable Factor (dB)
 3. The other emission levels were very low against the limit.
 4. Margin value = Emission level – Limit value.
 5. “ * “ : Fundamental frequency

4.3 MAXIMUM PEAK OUTPUT POWER

4.3.1 LIMITS OF MAXIMUM PEAK OUTPUT POWER MEASUREMENT

The Maximum Peak Output Power Measurement is 30dBm.

4.3.2 INSTRUMENTS

Description & Manufacturer	Model No.	Serial No.	Calibrated Until
R&S SPECTRUM ANALYZER	FSEK30	100049	Aug. 12, 2005
AGILENT SIGNAL GENERATOR	E8257C	MY43320668	Dec. 06, 2005
DIGITAL RT OSCILLOSCOPE	TDS1012	C037299	Dec. 07, 2005
NARDA DETECTOR	4503A	FSCM99899	NA

NOTE:

The calibration interval of the above test instruments is 12 months and the calibrations are traceable to NML/ROC and NIST/USA..

4.3.3 TEST PROCEDURES

1. A detector was used on the output port of the EUT. An oscilloscope was used to read the response of the detector.
2. Replaced the EUT by the signal generator. The center frequency of the S.G was adjusted to the center frequency of the measured channel.
3. Adjusted the power to have the same reading on oscilloscope. Record the power level.

4.3.4 DEVIATION FROM TEST STANDARD

No deviation

4.3.5 TEST SETUP



4.3.6 EUT OPERATING CONDITIONS

Same as Item 4.3.6

4.3.7 TEST RESULTS

802.11b DSSS modulation

EUT	Wireless 802.11g Cardbus Card	MODEL	WCB-210A
MODULATION TYPE	CCK	TRANSFER RATE	11Mbps
INPUT POWER (SYSTEM)	120Vac, 60 Hz	ENVIRONMENTAL CONDITIONS	25deg. C, 52%RH, 991hPa
TESTED BY	Gary Chang		

CHANNEL	CHANNEL FREQUENCY (MHz)	PEAK POWER OUTPUT (mW)	PEAK POWER OUTPUT (dBm)	PEAK POWER LIMIT (dBm)	PASS/FAIL
1	2412	66.069	18.20	30	PASS
6	2437	66.988	18.26	30	PASS
11	2462	66.527	18.23	30	PASS

802.11g OFDM modulation

EUT	Wireless 802.11g Cardbus Card	MODEL	WCB-210A
MODULATION TYPE	BPSK	TRANSFER RATE	6Mbps
INPUT POWER (SYSTEM)	120Vac, 60 Hz	ENVIRONMENTAL CONDITIONS	25deg. C, 52%RH, 991hPa
TESTED BY	Gary Chang		

CHANNEL	CHANNEL FREQUENCY (MHz)	PEAK POWER OUTPUT (mW)	PEAK POWER OUTPUT (dBm)	PEAK POWER LIMIT (dBm)	PASS/FAIL
1	2412	57.280	17.58	30	PASS
6	2437	58.076	17.64	30	PASS
11	2462	58.479	17.67	30	PASS



4.4 BAND EDGES MEASUREMENT

4.4.1 LIMITS OF BAND EDGES MEASUREMENT

Below -20dB of the highest emission level of operating band (in 100kHz Resolution Bandwidth).

4.4.2 TEST INSTRUMENTS

Description & Manufacturer	Model No.	Serial No.	Calibrated Until
R&S SPECTRUM ANALYZER	FSEK30	100049	Aug. 12, 2005

NOTE: The calibration interval of the above test instruments is 12 months and the calibrations are traceable to NML/ROC and NIST/USA.

4.4.3 TEST PROCEDURE

The transmitter output was connected to the spectrum analyzer via a low lose cable. Set both RBW and VBW of spectrum analyzer to 100 kHz and 100 kHz with suitable frequency span including 100 MHz bandwidth from band edge. The band edges was measured and recorded.

The spectrum plots (Peak RBW=VBW=100kHz ; Average RBW=1MHz, VBW=10Hz) are attached on the following pages.

4.4.4 DEVIATION FROM TEST STANDARD

No deviation

4.4.5 EUT OPERATING CONDITION

Same as Item 4.3.6



4.4.6 TEST RESULTS

The spectrum plots are attached on the following 12 images. D2 line indicates the highest level, and D1 line indicates the 20dB offset below D2. It shows compliance with the requirement in part 15.247(d).

4.4.7 TEST RESULTS

802.11b DSSS modulation

NOTE 1: The band edge emission plot on page 33 show 50.65dBc delta between carrier maximum power and local maximum emission in restrict band (2.3680GHz). The emission of carrier strength list in the test result of channel 1 at the item 4.2.7 is 108.88dBuV/m (Peak), so the maximum field strength in restrict band is $108.88 - 50.65 = 58.23$ dBuV/m which is under 74dBuV/m limit.

The band edge emission plot on page 33 show 59.00dBc delta between carrier maximum power and local maximum emission in restrict band (2.3861GHz). The emission of carrier strength list in the test result of channel 1 at the item 4.2.7 is 100.94dBuV/m (Average), so the maximum field strength in restrict band is $100.94 - 59.00 = 41.94$ dBuV/m which is under 54dBuV/m limit.

NOTE 2: The band edge emission plot on the page 34 show 51.28dBc delta between carrier maximum power and local maximum emission in restrict band (2.4975GHz). The emission of carrier strength list in the test result of channel 11 at the item 4.2.7 is 108.21dBuV/m (Peak), so the maximum field strength in restrict band is $108.21 - 51.28 = 56.93$ dBuV/m which is under 74dBuV/m limit.

The band edge emission plot on the page 35 show 58.05dBc delta between carrier maximum power and local maximum emission in restrict band (2.4882GHz). The emission of carrier strength list in the test result of channel 11 at the item 4.2.7 is 100.25dBuV/m (Average), so the maximum field strength in restrict band is $100.25 - 58.05 = 42.20$ dBuV/m which is under 54dBuV/m limit.

**802.11g OFDM modulation**

NOTE 1: The band edge emission plot on page 36 show 46.21dBc delta between carrier maximum power and local maximum emission in restrict band (2.3696GHz). The emission of carrier strength list in the test result of channel 1 at the item 4.2.7 is 103.62dBuV/m (Peak), so the maximum field strength in restrict band is $103.62 - 46.21 = 57.41$ dBuV/m which is under 74dBuV/m limit.

The band edge emission plot on page 36 show 53.87dBc delta between carrier maximum power and local maximum emission in restrict band (2.3900GHz). The emission of carrier strength list in the test result of channel 1 at the item 4.2.7 is 93.86dBuV/m (Average), so the maximum field strength in restrict band is $93.86 - 53.87 = 39.99$ dBuV/m which is under 54dBuV/m limit.

NOTE 2: The band edge emission plot on page 37 show 46.59dBc delta between carrier maximum power and local maximum emission in restrict band (2.4914GHz). The emission of carrier strength list in the test result of channel 11 at the item 4.2.7 is 104.05dBuV/m (Peak), so the maximum field strength in restrict band is $104.05 - 46.59 = 57.46$ dBuV/m which is under 74dBuV/m limit.

The band edge emission plot on page 38 show 52.78dBc delta between carrier maximum power and local maximum emission in restrict band (2.4835GHz). The emission of carrier strength list in the test result of channel 11 at the item 4.2.7 is 94.12dBuV/m (Average), so the maximum field strength in restrict band is $94.12 - 52.78 = 41.34$ dBuV/m which is under 54dBuV/m limit.



802.11b DSSS modulation

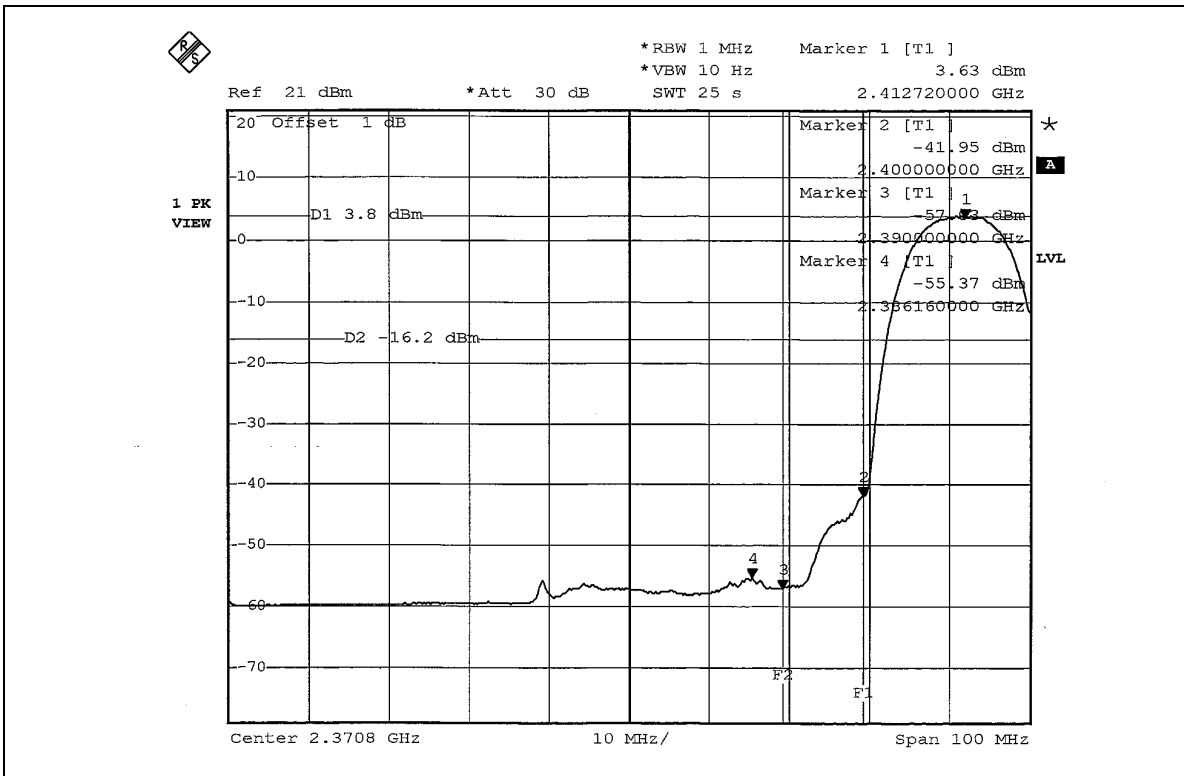
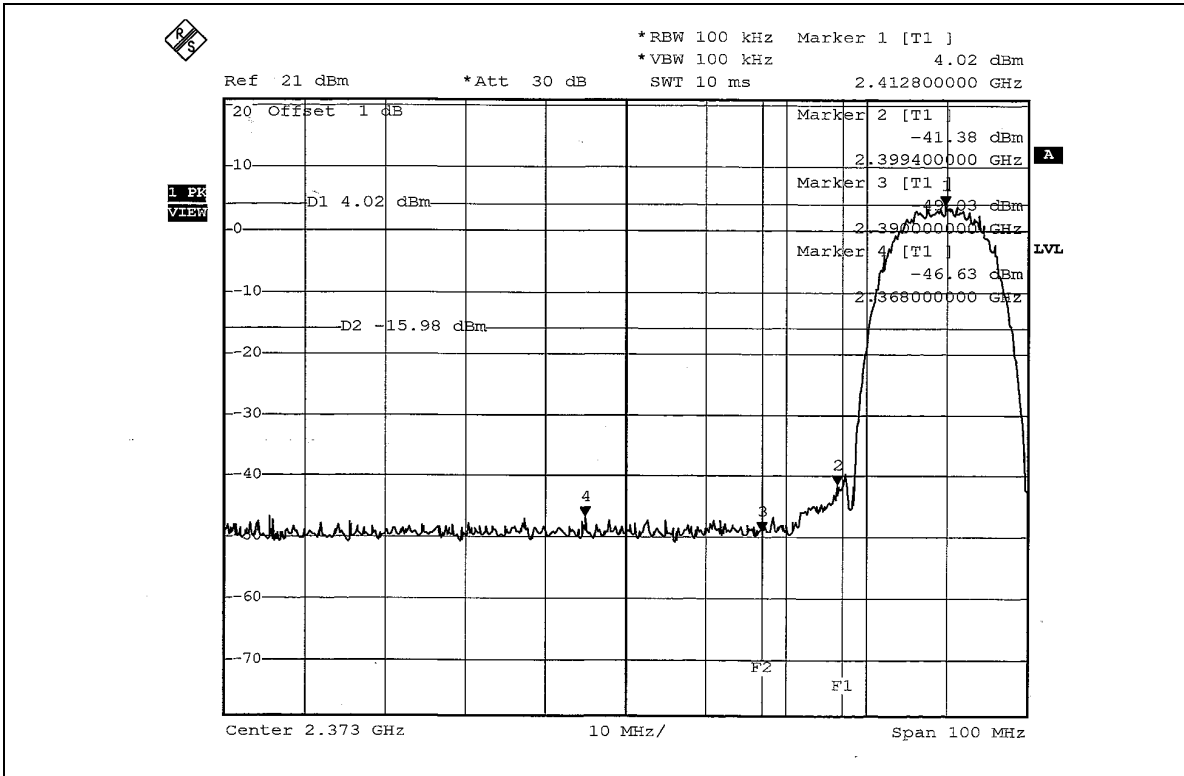

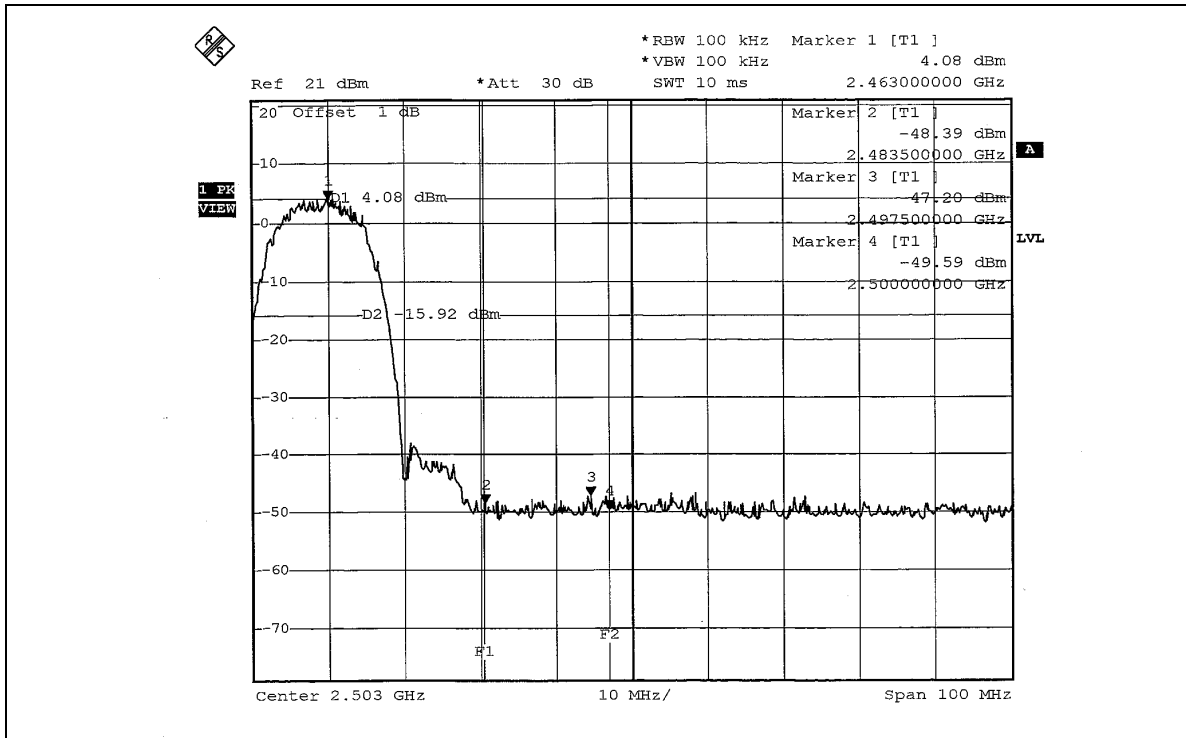
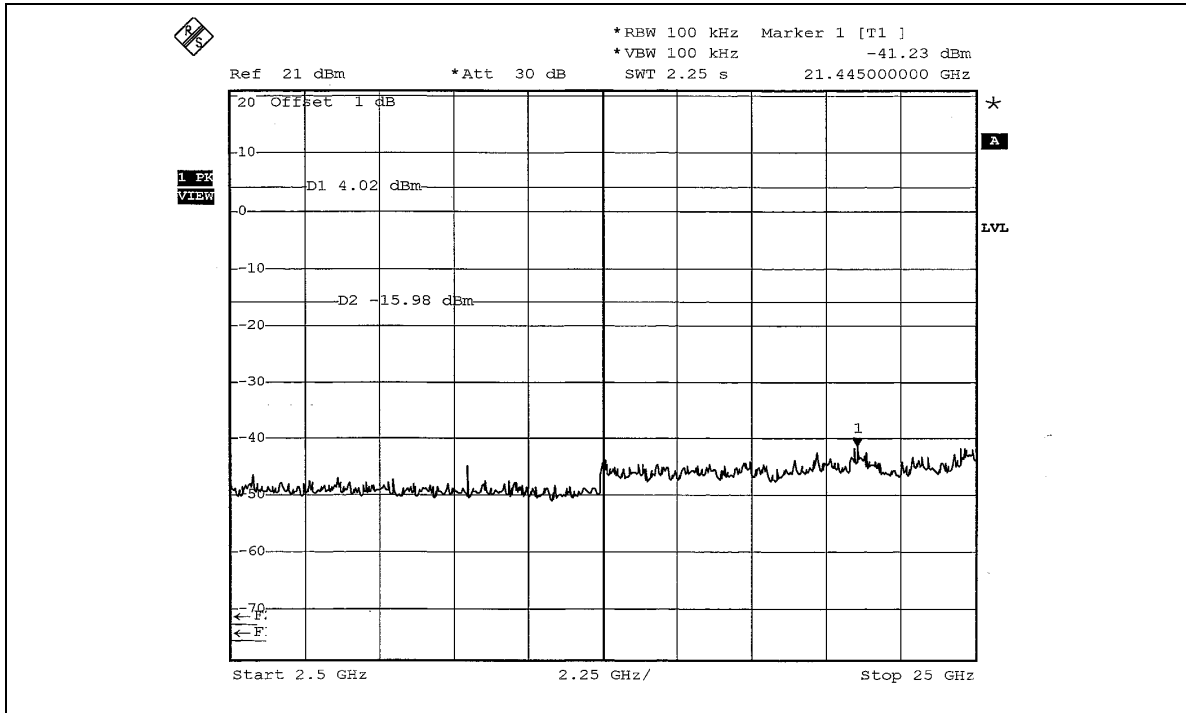

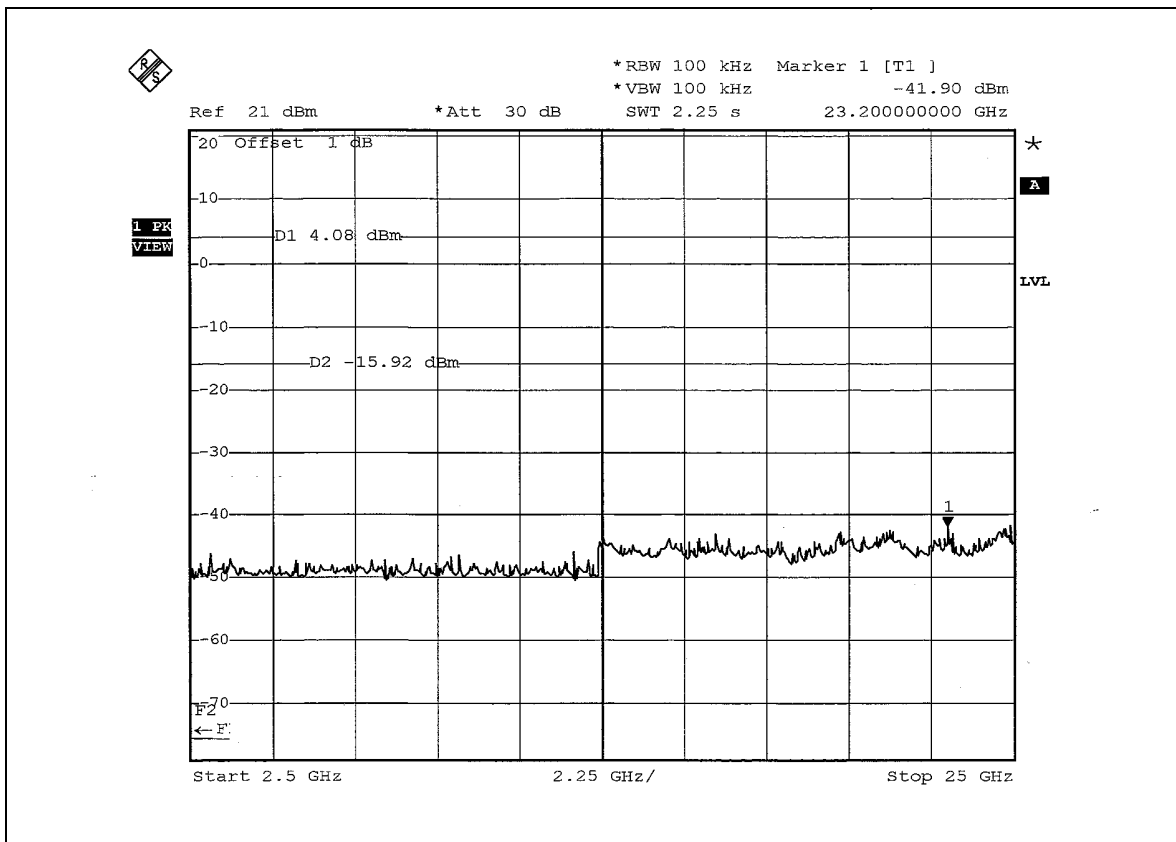
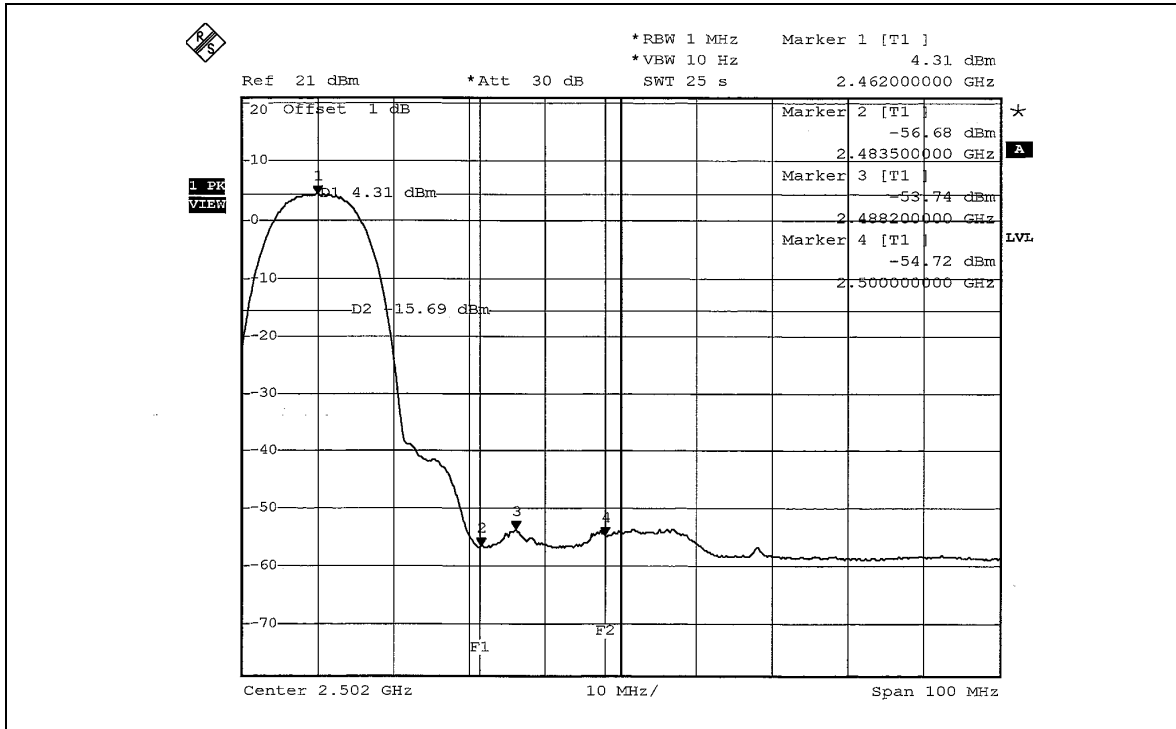



802.11g OFDM modulation

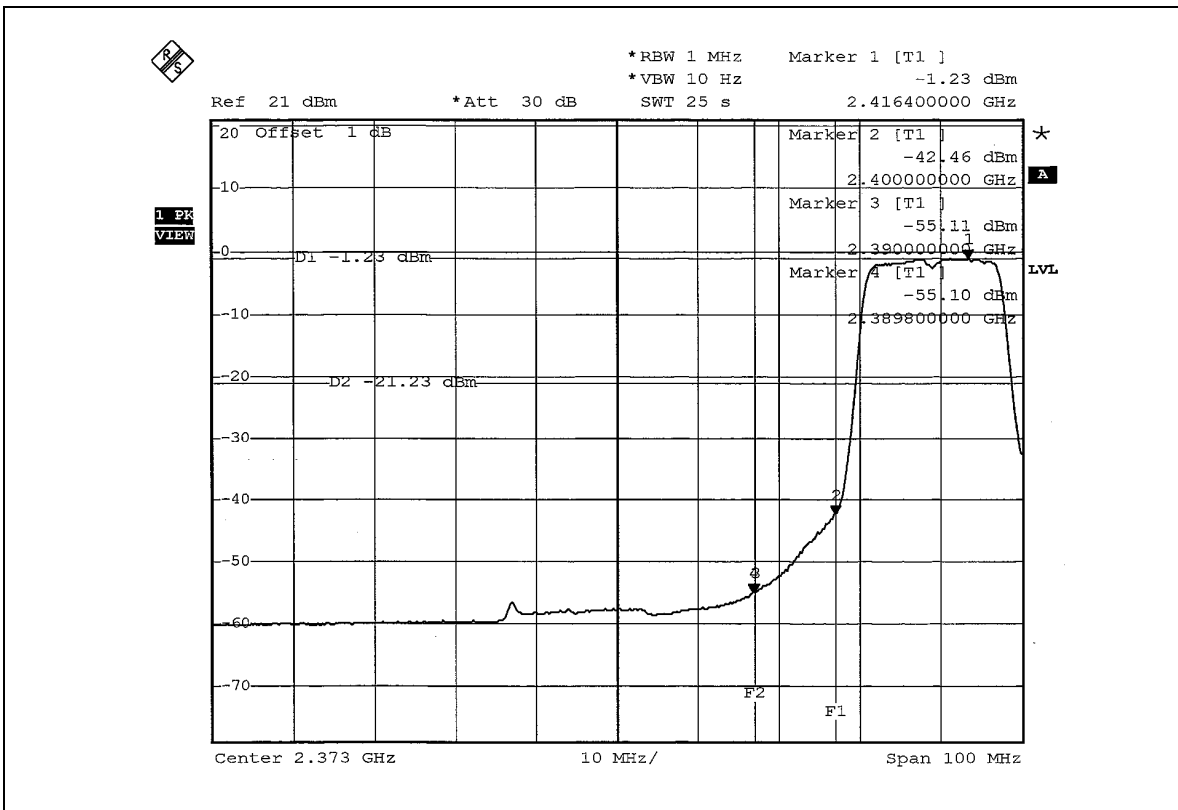
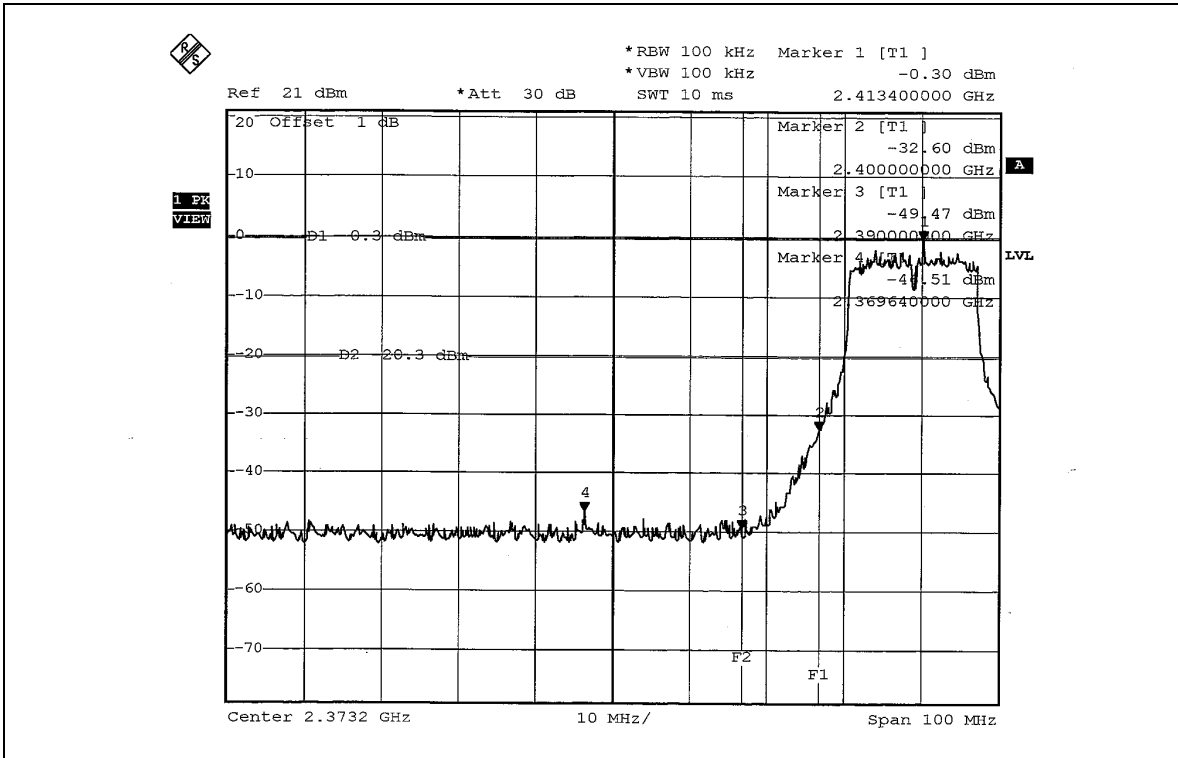

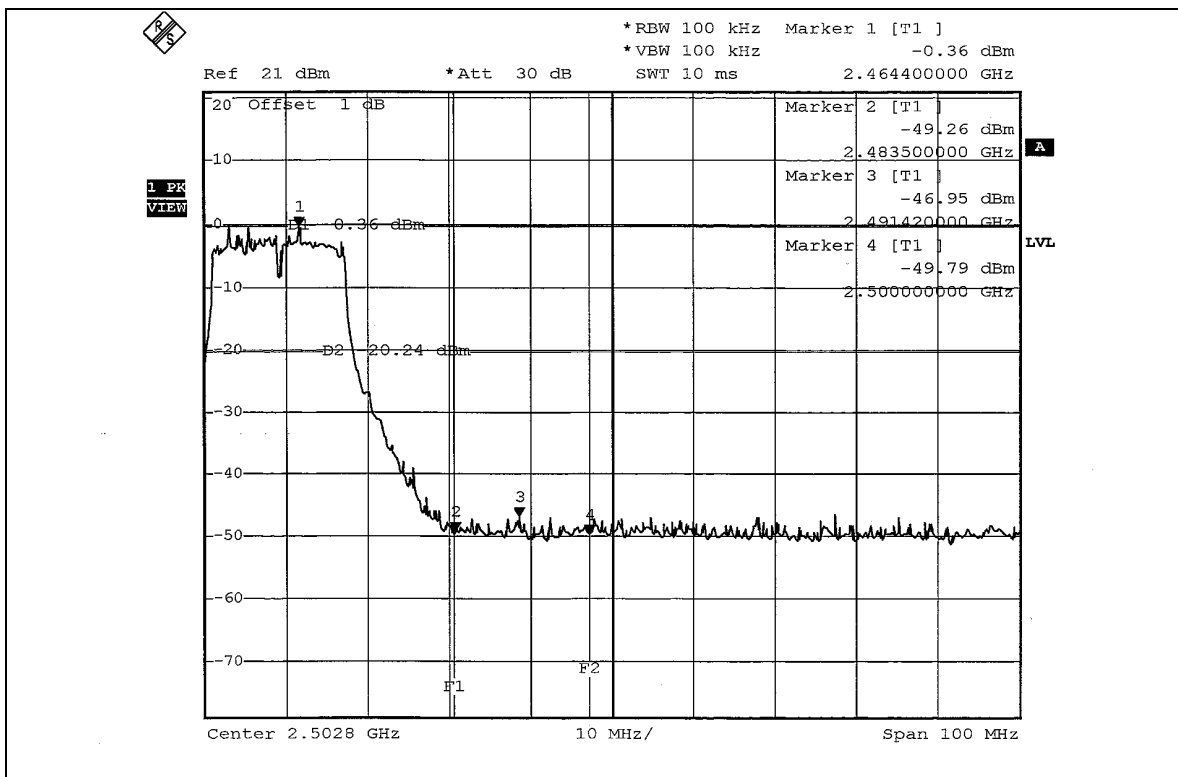
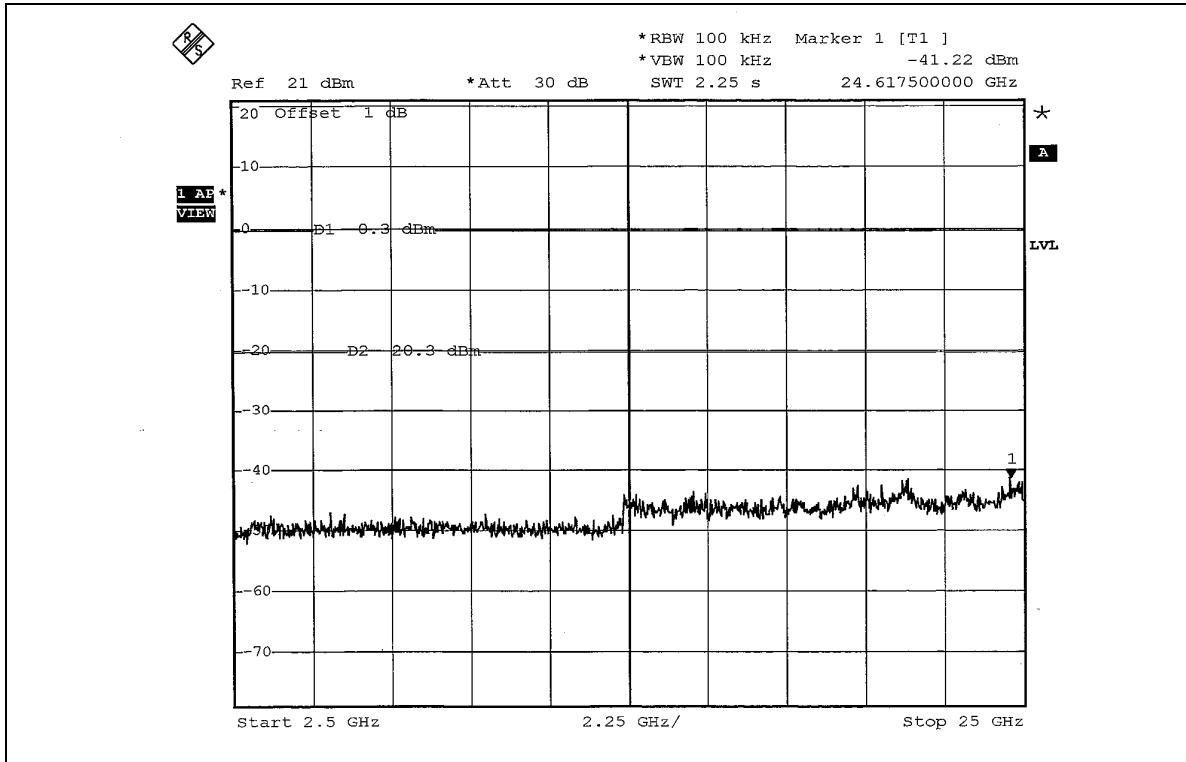

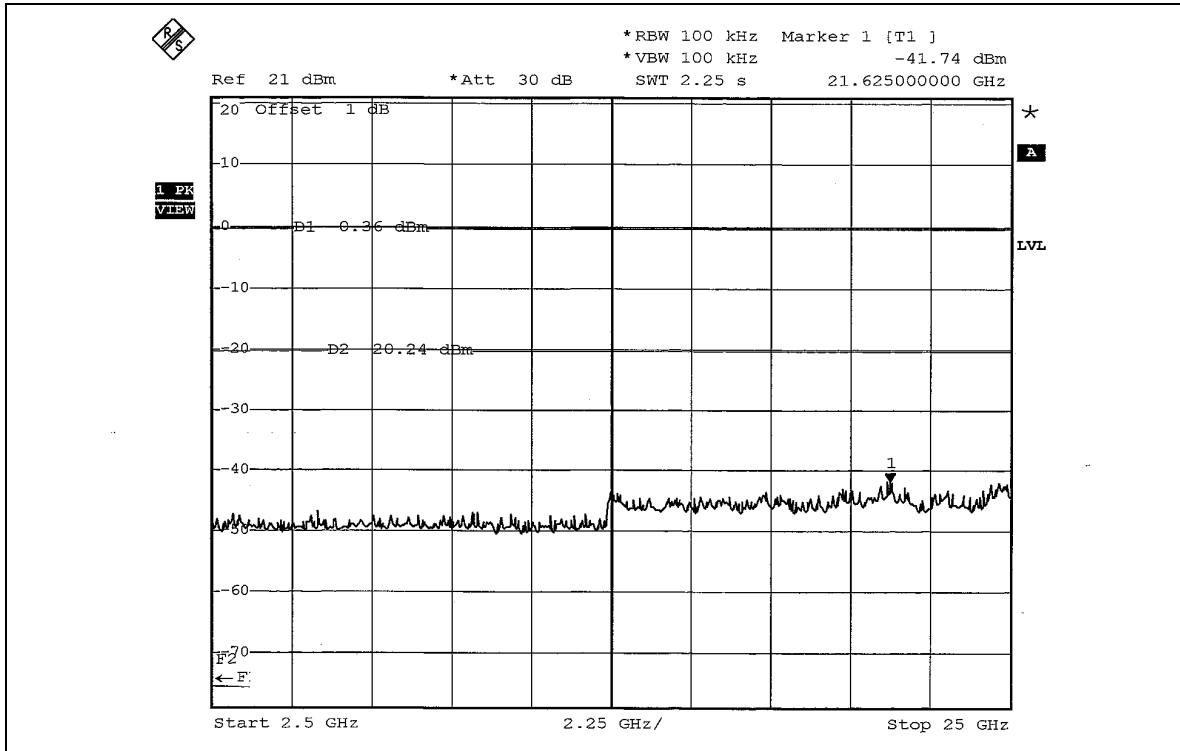
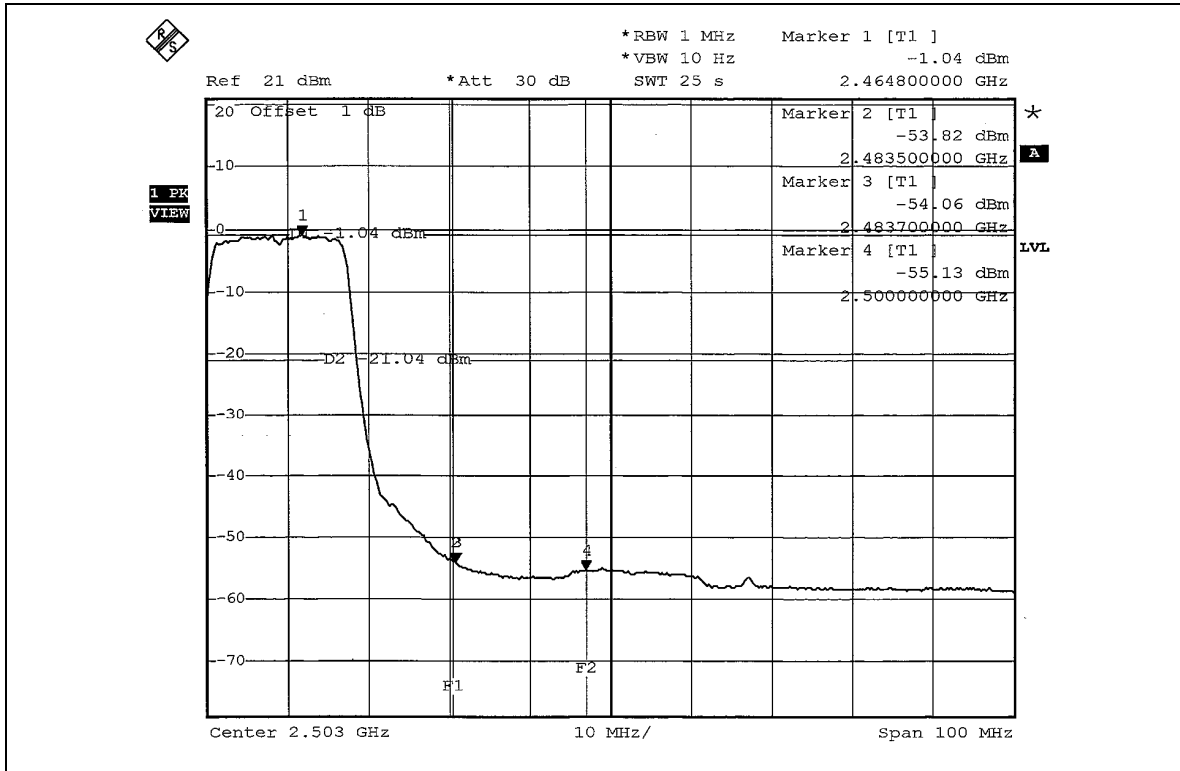

5. PHOTOGRAPHS OF THE TEST CONFIGURATION

CONDUCTED EMISSION TEST

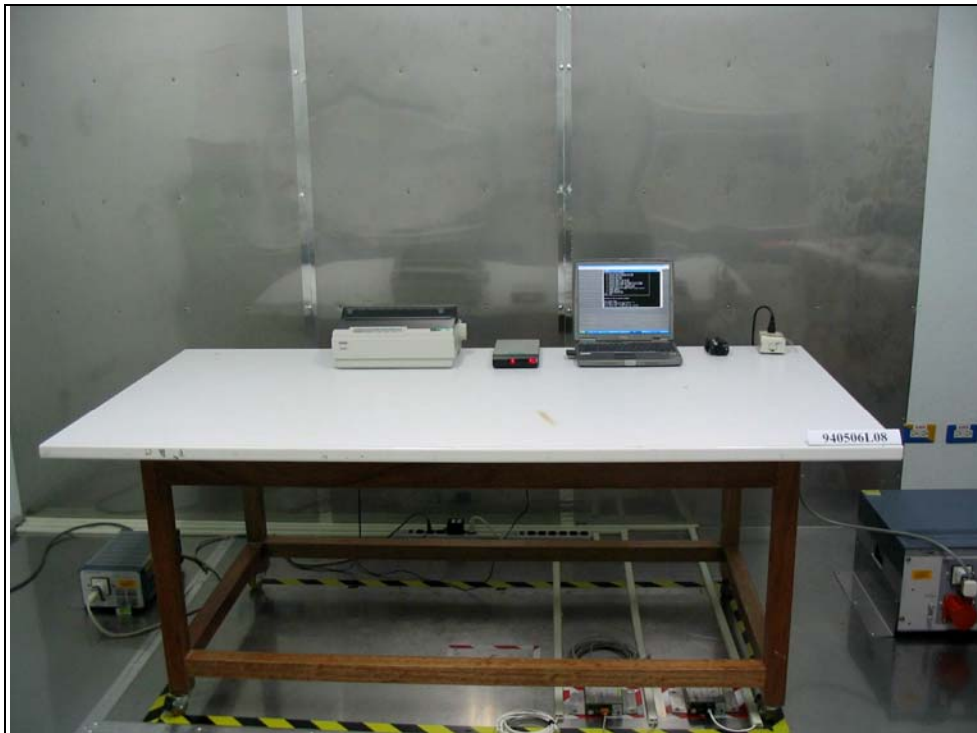

RADIATED EMISSION TEST

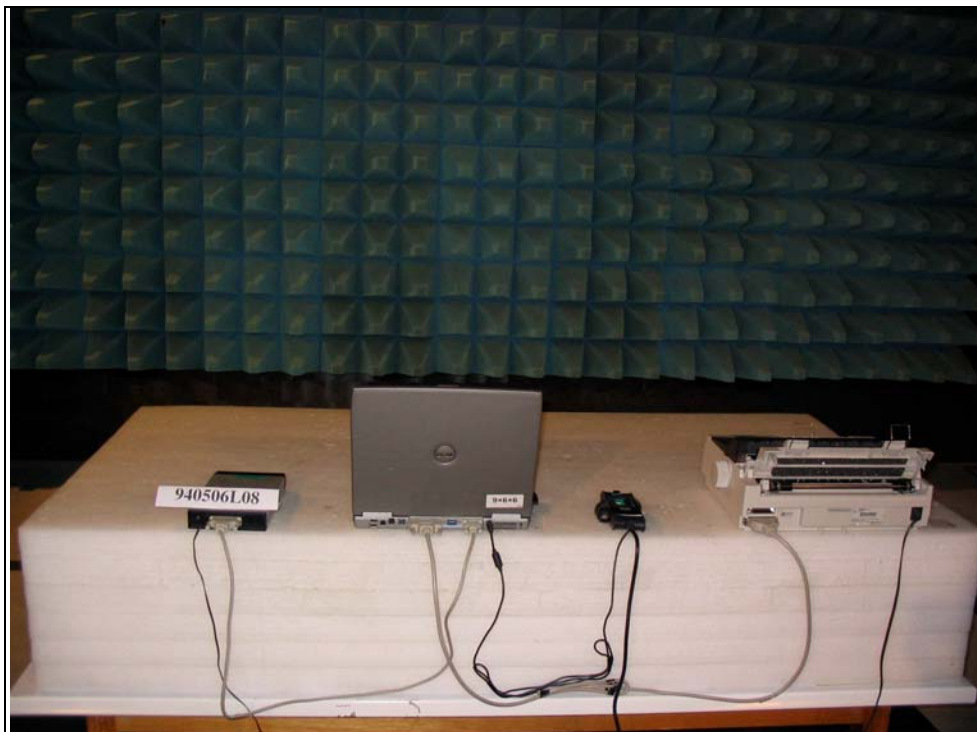



6. INFORMATION ON THE TESTING LABORATORIES

We, ADT Corp., were founded in 1988 to provide our best service in EMC, Radio, Telecom and Safety consultation. Our laboratories are accredited and approved by the following approval agencies according to ISO/IEC 17025.

USA	FCC, NVLAP, UL, A2LA
Germany	TUV Rheinland
Japan	VCCI
Norway	NEMKO
Canada	INDUSTRY CANADA , CSA
R.O.C.	CNLA, BSMI, DGT
Netherlands	Telefication
Singapore	PSB , GOST-ASIA(MOU)
Russia	CERTIS(MOU)

Copies of accreditation certificates of our laboratories obtained from approval agencies can be downloaded from our web site:

www.adt.com.tw/index_5/phtml. If you have any comments, please feel free to contact us at the following:

Linko EMC/RF Lab:

Tel: 886-2-26052180

Fax: 886-2-26052943

Hsin Chu EMC/RF Lab:

Tel: 886-3-5935343

Fax: 886-3-5935342

Hwa Ya EMC/RF/Safety Telecom Lab:

Tel: 886-3-3183232

Fax: 886-3-3185050

Linko RF Lab.

Tel: 886-3-3270910

Fax: 886-3-3270892

Web Site: www.adt.com.tw

The address and road map of all our labs can be found in our web site also