

Prüfbericht-Nr.: <i>Test report no.:</i>	CN21ITGY 001	Auftrags-Nr.: <i>Order no.:</i>	168333585	Seite 1 von 23 <i>Page 1 of 23</i>
Kunden-Referenz-Nr.: <i>Client reference no.:</i>	N/A	Auftragsdatum: <i>Order date:</i>	2021-09-01	
Auftraggeber: <i>Client:</i>	AfterShokz LLC 3200 Gracie Kiltz Lane, Suite 400, Austin, TX 78758, United States.			
Prüfgegenstand: <i>Test item:</i>	Loop100			
Bezeichnung / Typ-Nr.: <i>Identification / Type no.:</i>	CL101A (Trademark: AFTERSHOKZ, SHOKZ)			
Auftrags-Inhalt: <i>Order content:</i>	Test Report			
Prüfgrundlage: <i>Test specification:</i>	CFR47 FCC Part 15: Subpart C Section 15.247 RSS-247 Issue 2 February 2017 RSS-Gen Issue 5 March 2019			
Wareneingangsdatum: <i>Date of sample receipt:</i>	2021-10-12	Please refer to Photo Document		
Prüfmuster-Nr.: <i>Test sample no.:</i>	A003119946-001,006,007 A003150518-007~014			
Prüfzeitraum: <i>Testing period:</i>	2021-10-13 - 2021-11-05			
Ort der Prüfung: <i>Place of testing:</i>	TÜV Rheinland (Shenzhen) Co., Ltd.			
Prüflaboratorium: <i>Testing laboratory:</i>	TÜV Rheinland (Shenzhen) Co., Ltd.			
Prüfergebnis*: <i>Test result*:</i>	Pass			
geprüft von: <i>tested by:</i>	 Chris Chen	genehmigt von: <i>authorized by:</i>	 Lin Lin	
Datum: <i>Date:</i>	2021-11-16	Ausstellungsdatum: <i>Issue date:</i>	2021-11-16	
Stellung / Position:	Section Manager	Stellung / Position:	Reviewer	
Sonstiges / Other:	FCC ID: SHKCL101A IC: 10978A-CL101A HVIN: CL101A			
Zustand des Prüfgegenstandes bei Anlieferung: <i>Condition of the test item at delivery:</i>	Prüfmuster vollständig und unbeschädigt <i>Test item complete and undamaged</i>			
* Legende:	1 = sehr gut P(ass) = entspricht o.g. Prüfgrundlage(n)	2 = gut F(ail) = entspricht nicht o.g. Prüfgrundlage(n)	3 = befriedigend N/A = nicht anwendbar	4 = ausreichend N/T = nicht getestet
* Legend:	1 = very good P(ass) = passed a.m. test specification(s)	2 = good F(ail) = failed a.m. test specification(s)	3 = satisfactory N/A = not applicable	4 = sufficient N/T = not tested
Dieser Prüfbericht bezieht sich nur auf das o.g. Prüfmuster und darf ohne Genehmigung der Prüfstelle nicht auszugsweise vervielfältigt werden. Dieser Bericht berechtigt nicht zur Verwendung eines Prüfzeichens. <i>This test report only relates to the a. m. test sample. Without permission of the test center this test report is not permitted to be duplicated in extracts. This test report does not entitle to carry any test mark.</i>				

V05

Test Summary

5.1.1 ANTENNA REQUIREMENT*RESULT: Pass***5.1.2 MAXIMUM PEAK CONDUCTED OUTPUT POWER***RESULT: Pass***5.1.3 99% BANDWIDTH***RESULT: Pass***5.1.4 20DB BANDWIDTH***RESULT: Pass***5.1.5 CARRIER FREQUENCY SEPARATION***RESULT: Pass***5.1.6 NUMBER OF HOPPING FREQUENCY***RESULT: Pass***5.1.7 TIME OF OCCUPANCY***RESULT: Pass***5.1.8 CONDUCTED SPURIOUS EMISSIONS MEASURED IN 100 KHZ BANDWIDTH***RESULT: Pass***5.1.9 RADIATED SPURIOUS EMISSION***RESULT: Pass***5.1.10 CONDUCTED EMISSION***RESULT: Pass*

Contents

1	GENERAL REMARKS	4
1.1	COMPLEMENTARY MATERIALS	4
2	TEST SITES	4
2.1	TEST FACILITIES	4
2.2	LIST OF TEST AND MEASUREMENT INSTRUMENTS.....	5
2.3	TRACEABILITY	6
2.4	CALIBRATION	6
2.5	MEASUREMENT UNCERTAINTY.....	6
2.6	LOCATION OF ORIGINAL DATA.....	6
2.7	STATUS OF FACILITY USED FOR TESTING.....	6
3	GENERAL PRODUCT INFORMATION	7
3.1	PRODUCT FUNCTION AND INTENDED USE.....	7
3.2	RATINGS AND SYSTEM DETAILS	7
3.3	INDEPENDENT OPERATION MODES	9
3.4	NOISE GENERATING AND NOISE SUPPRESSING PARTS	9
3.5	SUBMITTED DOCUMENTS.....	9
4	TEST SET-UP AND OPERATION MODES	10
4.1	PRINCIPLE OF CONFIGURATION SELECTION	10
4.2	TEST OPERATION AND TEST SOFTWARE	10
4.3	SPECIAL ACCESSORIES AND AUXILIARY EQUIPMENT	10
4.4	COUNTERMEASURES TO ACHIEVE EMC COMPLIANCE	10
4.5	TEST SETUP DIAGRAM	11
5	TEST RESULTS	13
5.1	TRANSMITTER REQUIREMENT & TEST SUITES	13
5.1.1	<i>Antenna Requirement</i>	<i>13</i>
5.1.2	<i>Maximum Peak Conducted Output Power</i>	<i>14</i>
5.1.3	<i>99% Bandwidth</i>	<i>15</i>
5.1.4	<i>20dB Bandwidth</i>	<i>16</i>
5.1.5	<i>Carrier Frequency Separation.....</i>	<i>17</i>
5.1.6	<i>Number of Hopping Frequency</i>	<i>18</i>
5.1.7	<i>Time of Occupancy</i>	<i>19</i>
5.1.8	<i>Conducted Spurious Emissions Measured in 100 kHz Bandwidth</i>	<i>20</i>
5.1.9	<i>Radiated Spurious Emission</i>	<i>21</i>
5.1.10	<i>Conducted Emission</i>	<i>22</i>
6	PHOTOGRAPHS OF THE TEST SET-UP	23
7	LIST OF TABLES.....	23

1 General Remarks

1.1 Complementary Materials

All attachments are integral parts of this test report. This applies especially to the following appendix:

Appendix A: Photographs of the Test Set-up

Appendix B: Test Results of Bluetooth BR/EDR mode

2 Test Sites

2.1 Test Facilities

TÜV Rheinland (Shenzhen) Co., Ltd.

362 Huanguan Road Middle Longhua District, Shenzhen 518110 People's Republic of China

FCC Registration No.: 694916

ISED wireless device testing laboratory: 25069

2.2 List of Test and Measurement Instruments

Table 1: List of Test and Measurement Equipment

Radio Spectrum Testing (SRD-Tonscend)				
Equipment	Manufacturer	Model	Serial No.	Cal. until
EXA Signal Analyzer, Multi-touch	Keysight	N9010B	MY60241175	2022-09-28
MXG X-Series RF Vector Signal Generator	Keysight	N5182B	MY61250137	2022-09-28
EXG X-Series Microwave Analog Signal Generator	Keysight	N5173B	MY61250141	2022-09-28
DC power supply	Keysight	E3642A	MY61276100	2022-09-28
Power Control Unit	Tonscend	JS0806-4ADC	N/A	2022-09-28
Automation Control Unit	Tonscend	JS0806-2	21C8060396	2022-09-28
Test Software	Tonscend	JS1120-3	N/A	N/A
Control PC	Lenovo	TianYi510S-071MB	YLX23JMF	N/A
Shielding Room 8#	Albatross	SR8	APC17151-SR8	2024-06-22
Unwanted Emission Testing (TS9975)				
Equipment	Manufacturer	Model	Serial No.	Cal. until
EMI Test Receiver	R&S	ESR 7	102021	2022-08-10
Signal Analyzer	R&S	FSV 40	101439	2022-08-09
System Controller Interface	R&S	SCI-100	S10010038	N/A
Filterbank	R&S	Wlan	100759	2022-08-09
OSP	R&S	OSP 120	102040	N/A
Pre-amplifier	R&S	SCU08F1	08320031	2022-08-09
Amplifier	R&S	SCU-18F	180070	2022-08-09
Amplifier	R&S	SCU40A	100475	2022-08-09
Trilog Broadband Antenna (30 MHz - 7 GHz)	Schwarzbeck	VULB 9162	193	2022-08-08
Double-Ridged Antenna (1 -18 GHz)	ETS-LINDGREN	3117	00218717	2022-08-08
Wideband Ridged Horn Antenna (18-40 GHz)	Steatite	QMS-00880	19067	2022-08-08
Active Loop Antenna	Schwarzbeck	FMZB 1513	302	2022-09-13
Test software	R&S	EMC32 (V10.60.10)	N/A	N/A
Control PC	Dell	OptiPlex 7050	36NV9P2	N/A
3m Semi-Anechoic Chamber	Albatross	SAC-3m	APC17151-SAC	2024-06-22

Conducted Emission				
Equipment	Manufacturer	Model No.	Serial No.	Cal. Until
EMI Test Receiver	R&S	ESR3	102680	2022-04-25
Artificial Mains Network	R&S	ENV216	101445	2022-04-25
EMC32 test software	R&S	EMC32(Ver.10.50.00)	N/A	N/A

2.3 Traceability

All measurement equipment calibrations are traceable to NIM (National Institute of Metrology) or where calibration is performed in other countries, to equivalent nationally recognized standards organizations.

2.4 Calibration

Equipment requiring calibration is calibrated periodically by the manufacturer or according to manufacturer's specifications. Additionally all equipment is verified for proper performance on a regular basis using in house standards or comparisons.

2.5 Measurement Uncertainty

The estimated combined standard uncertainty for radiated emissions and conducted emissions measurements as below table.

Parameter	Uncertainty
Radio Frequency	$\pm 1 \times 10^{-7}$
RF Power (conducted)	± 2.5 dB
Radiated Emission of Transmitter, valid up to 26.5 GHz	± 6 dB
Radiated Emission of Receiver, valid up to 26.5 GHz	± 6 dB
Conducted Emission, (9kHz to 150kHz)/(150kHz to 30MHz)	± 3.70 dB / ± 3.30 dB
Temperature	± 1 °C
Humidity	± 5 %
Voltage (DC)	± 1 %
Voltage (AC, <10kHz)	± 2 %

2.6 Location of Original Data

The original copies of all test data taken during actual testing were attached at Appendix A & B of this report and delivered to the applicant. A copy has been retained in the TÜV Rheinland (Shenzhen) Co., Ltd. file for certification follow-up purposes.

2.7 Status of Facility Used for Testing

The TÜV Rheinland (Shenzhen) Co., Ltd. Test facility located at 362 Huanguan Road Middle Longhua District, Shenzhen 518110 People's Republic of China is listed on the US Federal Communications Commission list of facilities approved to perform measurements.

3 General Product Information

3.1 Product Function and Intended Use

The EUT is a Loop100, which supports Bluetooth BR&EDR wireless technology.

For details refer to the User Manual, Technical Description and Circuit Diagram.

3.2 Ratings and System Details

Table 2: Technical Specification of EUT

General Information of EUT	Value
Kind of Equipment:	Loop100
Type Designation:	CL101A
Trademark:	AFTERSHOKZ, SHOKZ
FCC ID:	SHKCL101A
IC:	10978A-CL101A
HVIN:	CL101A
Testing Voltage:	DC 5V by USB port(PC input AC 120V/60Hz)
Antenna Type:	PIFA Antenna
Antenna Gain:	1.38 dBi
Technical Specification of Bluetooth BR/EDR	
Operating Frequency:	2402 MHz to 2480 MHz
Type of Modulation:	GFSK(BR), $\pi/4$ -DQPSK(EDR), 8DPSK(EDR)
Channel Number:	79 channels
Channel Separation:	1MHz

Table 3: RF Channel and Frequency of Bluetooth BR/EDR

RF Channel	Frequency (MHz)	RF Channel	Frequency (MHz)	RF Channel	Frequency (MHz)	RF Channel	Frequency (MHz)
0	2402.00	20	2422.00	40	2442.00	60	2462.00
1	2403.00	21	2423.00	41	2443.00	61	2463.00
2	2404.00	22	2424.00	42	2444.00	62	2464.00
3	2405.00	23	2425.00	43	2445.00	63	2465.00
4	2406.00	24	2426.00	44	2446.00	64	2466.00
5	2407.00	25	2427.00	45	2447.00	65	2467.00
6	2408.00	26	2428.00	46	2448.00	66	2468.00
7	2409.00	27	2429.00	47	2449.00	67	2469.00
8	2410.00	28	2430.00	48	2450.00	68	2470.00
9	2411.00	29	2431.00	49	2451.00	69	2471.00
10	2412.00	30	2432.00	50	2452.00	70	2472.00
11	2413.00	31	2433.00	51	2453.00	71	2473.00
12	2414.00	32	2434.00	52	2454.00	72	2474.00
13	2415.00	33	2435.00	53	2455.00	73	2475.00
14	2416.00	34	2436.00	54	2456.00	74	2476.00
15	2417.00	35	2437.00	55	2457.00	75	2477.00
16	2418.00	36	2438.00	56	2458.00	76	2478.00
17	2419.00	37	2439.00	57	2459.00	77	2479.00
18	2420.00	38	2440.00	58	2460.00	78	2480.00
19	2421.00	39	2441.00	59	2461.00		

Test frequencies are lowest channel: 2402 MHz, middle channel: 2441 MHz and highest channel: 2480 MHz for General 2.4GHz

3.3 Independent Operation Modes

The basic operation modes are:

- A. On, Bluetooth transmitting mode (BR & EDR mode)
 - 1) Low Channel
 - 2) Middle Channel
 - 3) High Channel
- B. On, Transmitting on Hopping channel
- C. On, Normal Operation(BT Link)
- D. Off

3.4 Noise Generating and Noise Suppressing Parts

Refer to Circuit Diagram for further details.

3.5 Submitted Documents

- Application Form
- Operation Description
- Schematics
- PCB Layout
- User Manual
- Block Diagram
- Rating Label
- Parts List

4 Test Set-up and Operation Modes

4.1 Principle of Configuration Selection

Radio Spectrum: The equipment under test (EUT) was configured at its highest power output in order to measure its highest possible radiation and conducted level. The test modes were adapted accordingly in reference to the instructions for use.

Emission: The equipment under test (EUT) was configured to measure its highest possible radiation level. The test modes were adapted accordingly in reference to the instructions for use.

4.2 Test Operation and Test Software

Test operation refers to test setup in chapter 5. All tests were performed according to the procedures in ANSI C63.10: 2013.

According to clause 3.1, all tests were performed on model CL101A in this report.

4.3 Special Accessories and Auxiliary Equipment

Table 4: Auxiliary Equipment Used during Test

Description	Manufacturer	Model	S/N
Laptop	Lenovo	T480	PF-16A6N8
Bluetooth Headset	--	--	--

4.4 Countermeasures to Achieve EMC Compliance

The test sample which has been tested contained the noise suppression parts as described in the Technical Construction File (TCF).

No additional measures were employed to achieve compliance.

4.5 Test Setup Diagram

Diagram of Measurement Configuration for Radiation Test (Below 1GHz)

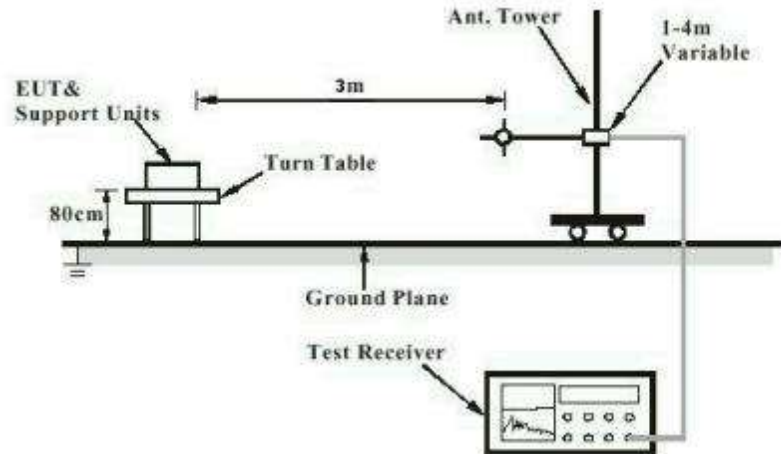

Diagram of Measurement Configuration for Radiation Test (Above 1GHz)

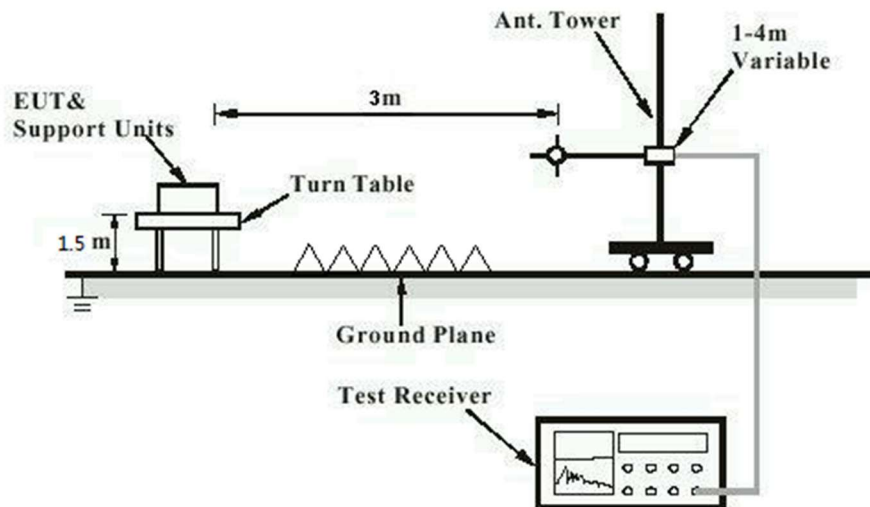

Diagram of Measurement Configuration for Mains Conduction Measurement

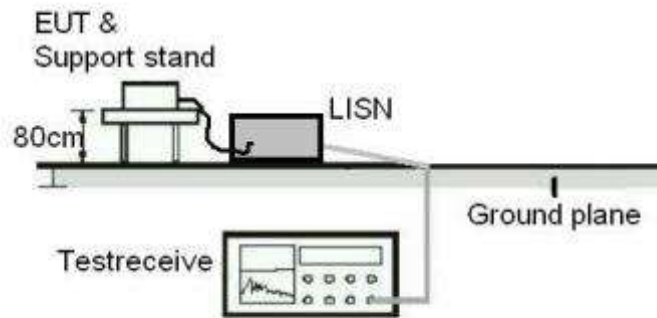
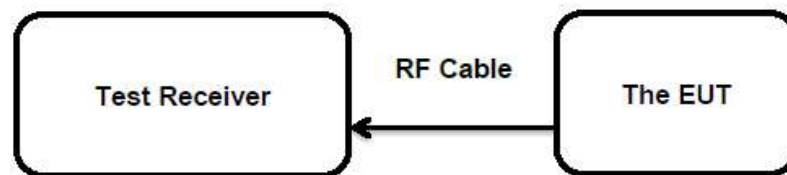

Diagram of Measurement Configuration for Conducted Transmitter Measurement



5 Test Results

5.1 Transmitter Requirement & Test Suites

5.1.1 Antenna Requirement

RESULT:

Pass

Test Specification

Test standard : FCC Part 15.247(b)(4) and Part 15.203
RSS-Gen Clause 6.8

According to the manufacturer declared, the EUT has a Integral antenna, the directional gain of antenna is 1.38 dBi, and the antenna connector is designed with permanent attachment and no consideration of replacement.

Therefore the EUT is considered sufficient to comply with the provision.

Refer to EUT Photo for further details.

5.1.3 99% Bandwidth

RESULT:**Pass****Test Specification**

Test standard	: FCC Part 15.247(a) RSS-Gen Clause 6.7
Basic standard	: ANSI C63.10: 2013
Kind of test site	: Shielded Room

Test Setup

Date of testing	: 2021-10-29
Input voltage	: DC 5V by USB port(PC input AC 120V/60Hz)
Operation mode	: A
Test channel	: Low / Middle / High
Ambient temperature	: 24.8 °C
Relative humidity	: 55 %
Atmospheric pressure	: 101 kPa

For the measurement records, refer to the appendix B.

5.1.4 20dB Bandwidth

RESULT:**Pass****Test Specification**

Test standard : FCC Part 15.247(a)(1)
RSS-247 Clause 5.1(a)

Basic standard : ANSI C63.10: 2013

Kind of test site : Shielded Room

Test Setup

Date of testing : 2021-10-29

Input voltage : DC 5V by USB port(PC input AC 120V/60Hz)

Operation mode : A

Test channel : Low / Middle / High

Ambient temperature : 24.8 °C

Relative humidity : 55 %

Atmospheric pressure : 101 kPa

For the measurement records, refer to the appendix B.

5.1.5 Carrier Frequency Separation

RESULT:**Pass****Test Specification**

Test standard	:	FCC Part 15.247(a)(1) RSS-247 Clause 5.1(b)
Basic standard	:	ANSI C63.10: 2013
Limits	:	≥ 25kHz or 2/3 of 20dB bandwidth, whichever is greater
Kind of test site	:	Shielded Room

Test Setup

Date of testing	:	2021-10-29
Input voltage	:	DC 5V by USB port(PC input AC 120V/60Hz)
Operation mode	:	B
Test channel	:	Low / Middle / High
Ambient temperature	:	24.8 °C
Relative humidity	:	55 %
Atmospheric pressure	:	101 kPa

For the measurement records, refer to the appendix B.

5.1.6 Number of Hopping Frequency

RESULT:**Pass****Test Specification**

Test standard	:	FCC part 15.247(a)(1)(iii) RSS-247 Clause 5.1(d)
Basic standard	:	ANSI C63.10: 2013
Limits	:	≥ 15 non-overlapping channels
Kind of test site	:	Shielded Room

Test Setup

Date of testing	:	2021-10-29
Input voltage	:	DC 5V by USB port(PC input AC 120V/60Hz)
Operation mode	:	B
Ambient temperature	:	24.8 °C
Relative humidity	:	55 %
Atmospheric pressure	:	101 kPa

For the measurement records, refer to the appendix B.

5.1.7 Time of Occupancy

RESULT:**Pass****Test Specification**

Test standard	:	FCC part 15.247(a)(1)(iii) RSS-247 Clause 5.1(d)
Basic standard	:	ANSI C63.10: 2013
Limits	:	< 0.4s
Kind of test site	:	Shielded Room

Test Setup

Date of testing	:	2021-10-29
Input voltage	:	DC 5V by USB port(PC input AC 120V/60Hz)
Operation mode	:	B
Test channel	:	Low / Middle / High
Ambient temperature	:	24.8 °C
Relative humidity	:	55 %
Atmospheric pressure	:	101 kPa

For the measurement records, refer to the appendix B.

5.1.8 Conducted Spurious Emissions Measured in 100 kHz Bandwidth

RESULT:**Pass****Test Specification**

Test standard	: FCC Part 15.247(d) RSS-247 Clause 5.5
Basic standard	: ANSI C63.10: 2013
Limits	: 20dB (below that in the 100kHz bandwidth within the band that contains the highest level of the desired power); In addition, radiated emissions which fall in the restricted bands, must also comply with the radiated emission limits specified in 15.209(a)
Kind of test site	: Shielded Room

Test Setup

Date of testing	: 2021-10-29
Input voltage	: DC 5V by USB port(PC input AC 120V/60Hz)
Operation mode	: A
Test channel	: Low / Middle / High
Ambient temperature	: 24.8 °C
Relative humidity	: 55 %
Atmospheric pressure	: 101 kPa

Test results of 100kHz Bandwidth of Frequency Band Edge by Conducted method refer to test plots, and compliance is achieved as well.

For the measurement records, refer to the appendix B.

5.1.9 Radiated Spurious Emission

RESULT:**Pass****Test Specification**

Test standard	: FCC Part 15.247(d) & FCC Part 15.205 RSS-247 Clause 3.3
Basic standard	: ANSI C63.10: 2013
Limits	: Refer to 15.209(a) of FCC part 15.247(d) RSS-Gen Section 8.9 & 8.10
Kind of test site	: 3m Semi-anechoic Chamber

Test Setup

Date of testing	: 2021-10-15 to 2021-10-26
Input voltage	: DC 5V by USB port(PC input AC 120V/60Hz)
Operation mode	: A
Test channel	: Low / Middle / High
Ambient temperature	: Refer to test result
Relative humidity	: Refer to test result
Atmospheric pressure	: 101 kPa

Remark:

Testing was carried out within frequency range 9kHz to the tenth harmonics. Only the worst case spurious emissions configuration of the each mode were reported.

For the measurement records, refer to the appendix B.

5.1.10 Conducted Emission**RESULT:****Pass****Test Specification**

Test standard	:	FCC Part 15.207(a) RSS-Gen Section 8.8
Basic standard	:	ANSI C63.10: 2013
Frequency range	:	0.15 – 30MHz
Limits	:	FCC Part 15.207(a) RSS-Gen Table 4
Kind of test site	:	Shielded Room

Test Setup

Date of testing	:	2021-10-14
Input voltage	:	DC 5V by USB port(PC input AC 120V/60Hz)
Operation mode	:	C
Earthing	:	Not connected
Ambient temperature	:	22 °C
Relative humidity	:	64 %
Atmospheric pressure	:	101 kPa

For the measurement records, refer to the appendix B.

6 Photographs of the Test Set-Up

For photographs of the test set-up, refer to the appendix A.

7 List of Tables

Table 1: List of Test and Measurement Equipment.....	5
Table 2: Technical Specification of EUT	7
Table 3: RF Channel and Frequency of Bluetooth BR/EDR.....	8
Table 4: Auxiliary Equipment Used during Test	10
Table 5: Test Result of Maximum Peak Conducted Output Power, Bluetooth BR & EDR.....	14