

Test Report of FCC Part 15 C for FCC Certificate

On Behalf of

Shenzhen Delux Industry Co., Ltd.

FCC ID: SGPM618G1608
Product Description: Wireless mouse
Model No.: M618GX, M618GB

Prepared for: Shenzhen Delux Industry Co., Ltd.

Delux Industrial Park, Lanzhu Street, New Pingshan District,
Shenzhen City, P.R. China

Prepared by: Shenzhen QC Testing Laboratory Co., Ltd.

1stFloor,Building A, Huawan Industrial Park, Gushu,Xixiang Street,
Baoan,518126,Shenzhen,China

Tel: 0755-23008269

Fax: 0755-23726780

Report No.: QCT16ER-0245-01

Issue Date: Jul 21, 2016

Test Date: Jul 12~20, 2016

Tested by:

Kare Gao

Kare Gao

Reviewed by:

Carmi Du

Carmi Du

Approved by:

Kendy Wang

Kendy Wang

TABLE OF CONTENTS

1. GENERAL INFORMATION 3

1.1 Client Information 3

1.2 Related Submittal(s) / Grant (s)..... 4

1.3 Test Methodology 4

1.4 Test Facility 4

2. SYSTEM TEST CONFIGURATION 5

2.1 EUT Configuration 5

2.2 EUT Exercise 5

2.4 List of Measuring Equipments 6

3. SUMMARY OF TEST RESULTS..... 7

4. TEST OF CONDUCTED EMISSION 8

4.1 Applicable Standard 8

4.2 Test Setup Diagram 8

5. 20DB BANDWIDTH 9

5.1 Limit..... 9

5.2 TEST CONFIGURATION 9

6. BAND EDGES MEASUREMENT 11

6.1 Limit of Band Edges Measurement 11

6.2 Radiate EUT Setup 11

6.3 Test Procedure 12

6.4 Test Result..... 12

7. SPURIOUS EMISSIONS..... 14

7.1 Limit of Spurious Emissions 14

7.2 EUT Setup 15

7.3 Test Procedure 16

7.4 Spurious Emissions Test Result..... 17

8. ANTENNA REQUIREMENT 23

8.1 Standard Applicable..... 23

8.2 Antenna Connected Construction 23

1. GENERAL INFORMATION

1.1 Client Information

Applicant: **Shenzhen Delux Industry Co., Ltd.**
Address of applicant: Delux Industrial Park, Lanzhu Street, New Pingshan District,
Shenzhen City, P.R.China
Manufacturer: **Shenzhen Delux Industry Co., Ltd.**
Address of manufacturer: Delux Industrial Park, Lanzhu Street, New Pingshan District,
Shenzhen City, P.R.China

General Description of E.U.T

Items	Description
EUT Description:	Wireless mouse
Trade Name:	N/A
Model No.:	M618GX, M618GB
Test Model No.:	M618GB
Modulation Type:	GFSK
Frequency Band:	2405 MHz ~ 2472 MHz
Number of Channels:	68
Channel Bandwidth:	1MHz
Antenna Type:	Built-in Antenna
Antenna Gain:	0.0dBi
Rated Voltage:	Mouse : 3.0V DC

Remark The test data gathered are from the production sample provided by the manufacturer.
Supplementary models have the same circuit, but with different appearance*

1.2 Related Submittal(s) / Grant (s)

This submittal(s) is a test report based on the Electromagnetic Interference (EMI) tests performed on the EUT. The EMI measurements were performed according to the measurement procedure described in ANSI C63.10 - 2013.

The tests were performed in order to determine compliance with Section 15.107 and 15.109 under the FCC Rules Part 15 Subpart B and Section 15.207, 15.209, 15.249 under the FCC Rules Part 15 Subpart C.

1.3 Test Methodology

Both conducted and radiated testing were performed according to the procedures in ANSI C63.10 - 2013, American National Standard for Methods of Measurement of Radio-Noise Emissions from Low-Voltage Electrical and Electronic Equipment in the range of 9 kHz to 40 GHz. Radiated testing was performed at an antenna to EUT distance 3 meters.

1.4 Test Facility

All measurement required was performed at Shenzhen CTL Testing Technology Co., Ltd. at Floor 1-A, Baisha Technology Park, No.3011, Shaheji Road, Nanshan District, Shenzhen, China 518055
The test facility is recognized, certified, or accredited by the following organizations:

CNAS – Registration No.: L5540

Shenzhen CTL Testing Technology Co., Ltd. To ISO/IEC 17025:25 General Requirements for the Competence of Testing and Calibration Laboratories (CNAS-CL01 Accreditation Criteria for the Competence of Testing and Calibration Laboratories) for the competence in the field of testing. The acceptance letter from the CNAS is maintained in our files: Registration: L5540, March, 2012.

2. SYSTEM TEST CONFIGURATION

The tests documented in this report were performed in accordance with ANSI C63.10-2013 and FCC CFR 47 Part 15 Subpart C.

2.1 EUT Configuration

The EUT configuration for testing is installed on RF field strength measurement to meet the Commissions requirement and operating in a manner that intends to maximize its emission characteristics in a continuous transmitting application.

2.2 EUT Exercise

The calibrated antennas used to sample the radiated field strength are mounted on a non-conductive, motorized antenna mast 3 or 10 meters from the leading edge of the turntable.

2.4 List of Measuring Equipments

Test equipments list of Shenzhen CTL Testing Technology Co., Ltd.

Item	Test Equipment	Manufacturer	Model No.	Serial No.	Last Cal.
1	ULTRA-BROADBAND ANTENNA	Sunol Sciences Corp.	JB1 Antenna	A061713	2016.05.22
2	EMI TEST RECEIVER	ROHDE & SCHWARZ	ESCI	1166.5950.03	2016.03.19
3	Coaxial	/	/	/	2016.05.22
4	Controller	EM Electronics	Controller EM 1000	N/A	2016.05.22
5	Horn antenna	Sunol sciences corp	DRH-118	A062013	2016.05.21
6	Horn antenna	SCHWARZBECK	BBHA9710	1562	2016.05.21
7	Loop antenna	ZHINAN	ZN30900A	3548	2016.05.21
8	Amplifier	HP	8447D	1937A02492	2016.4.25
9	Broadband preamplifier	SCHWARZBECK	BBV9718	9718-182	2016.4.25
10	Spectrum Analyzer	R&S	FSP	100397	2016.05.22

3. SUMMARY OF TEST RESULTS

FCC Rules	Description of Test	Result
15.207	Disturbance Voltage at The Mains Terminals	N/A , without AC main
15.215	20dB Bandwidth	Pass
15.249	Band Edges Measurement	Pass
15.249	Spurious Emission	Pass
15.203	Antenna Requirement	Pass

4. TEST OF CONDUCTED EMISSION

4.1 Applicable Standard

Section 15.207: For a Low-power Radio-frequency Device is designed to be connected to the AC power line, the radio frequency voltage that is conducted back onto the AC power line on any frequency or frequencies within the band 150 kHz to 30 MHz shall not exceed below limits table.

Frequency Range (MHz)	Limits (dBuV)	
	Quasi-Peak	Average
0.150~0.500	66~56	56~46
0.500~5.000	56	46
5.000~30.00	60	50

4.2 Test Setup Diagram

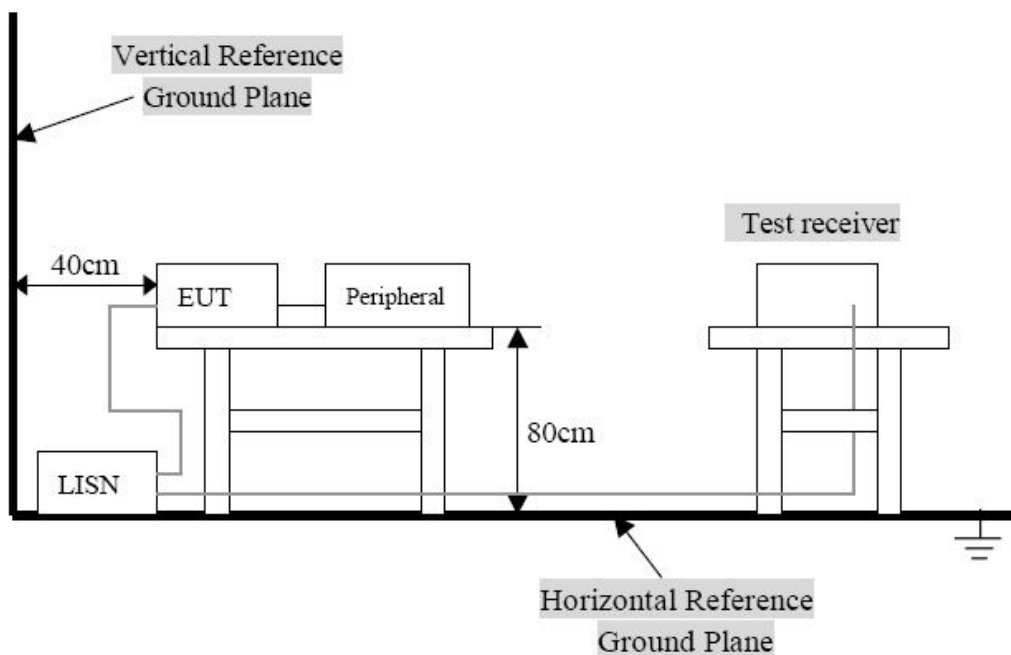

Remark: 1. The setup of EUT is according with per ANSI C63.10-2013 measurement procedure. The specification used was with the FCC 15.207 limits.

2. The EUT was charged on the base, and the base was connected to a 120 VAC/ 60Hz power source.

Notes: The EUT is powered by DC 3.0V from battery without AC mains, this test is unapplicable.

5. 20dB Bandwidth

5.1 Limit

N/A

5.2 TEST CONFIGURATION

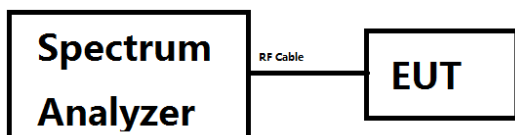

5.3 TEST PROCEDURE

1. Connect the antenna port(s) to the spectrum analyzer input.
2. Configure the spectrum analyzer as shown below (enter all losses between the transmitter output and the spectrum analyzer).
Center Frequency = channel center frequency
RBW $\geq 1\%BW$, VBW $\geq 3 \times RBW$
Sweep time = auto couple
Detector = Peak
Trace mode = max hold
3. Place the radio in continuous transmit mode, allow the trace to stabilize, view the transmitter waveform on the spectrum analyzer.
4. Measure the maximum width of the emission that is constrained by the frequencies associated with the two outermost amplitude points (upper and lower frequencies) that are attenuated by 20dB relative to the maximum level measured in the fundamental emission, and record the pertinent measurements.

5.4 TEST Result

Frequency(MHz)	20dB Bandwidth(MHz)
2405	1.51
2448	1.90
2472	1.95

CH Low

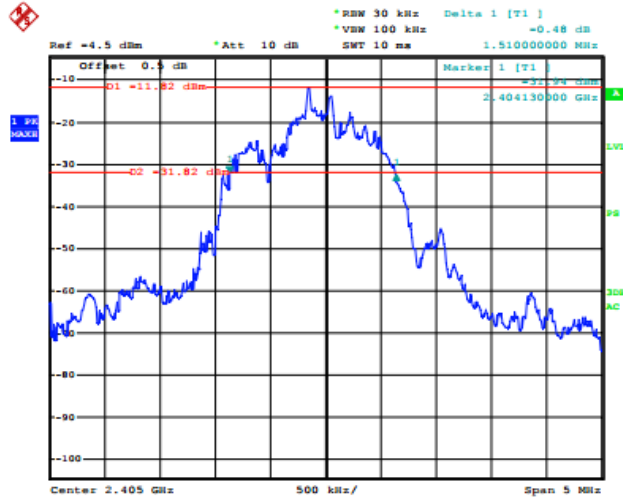

CH Mid

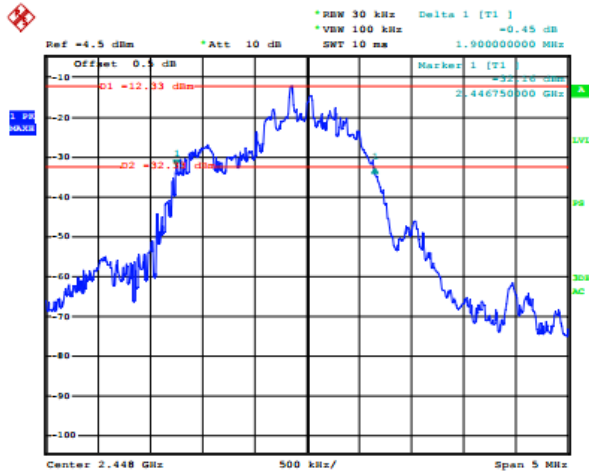

CH High



6. BAND EDGES MEASUREMENT

6.1 Limit of Band Edges Measurement

1. In the above emission table, the tighter limit applies at the band edges.
2. As shown in Section 15.35(b), for frequencies above 1000 MHz, the above field strength limits in paragraphs (a) and (b) of this section are based on average limits. However, the peak field strength of any emission shall not exceed the maximum permitted average limits specified above by more than 20 dB under any condition of modulation. For point-to-point operation under paragraph (b) of this section, the peak field strength shall not exceed 2500 millivolts/meter at 3 meters along the antenna azimuth.

Frequency (MHz)	Field Strength ($\mu\text{V}/\text{m}$ at 3-meter)	Field Strength ($\text{dB}\mu\text{V}/\text{m}$ at 3-meter)
30-88	100	40
88-216	150	43.5
216-960	200	46
Above 960	500	54

Note: (1) The tighter limit shall apply at the edge between two frequency bands.

- (2) The emission limits shown in the above table are based on measurement employing a CISPR quasi-peak detector and above 1000MHz are based on measurements employing an average detector.

6.2 Radiate EUT Setup

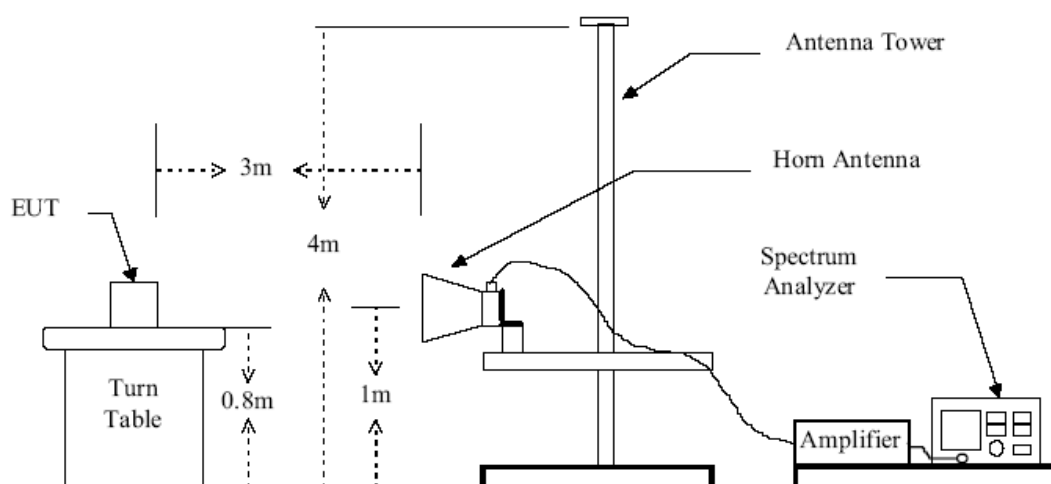

Figure 2 : Frequencies measured above 1 GHz configuration

6.3 Test Procedure

Maximizing procedure was performed on the highest emissions to ensure that the EUT complied with all installation combinations.

- 1). Configure the EUT according to ANSI C63.10:2013
- 2). The EUT was placed on the top of the turntable 0.8m(Below 1GHz),1.5m(Above 1GHz) above ground.
- 3). The receiving antenna was placed 3 meters far away from the turntable.
- 4). The turntable was rotated by 360 degrees to determine the position of the highest radiation.
- 5). The height of the broadband receiving antenna was varied between one meter and four meters above ground to find the maximum emission field strength of both horizontal and vertical polarization. For each suspected emission, the antenna tower was scanned (from 1 M to 4 M) and then the turntable was rotated (from 0 degree to 360 degrees) to find the maximum reading.

6.4 Test Result

Radio test result

Frequency (MHz)	Antenna Polarization	Emission Read Value (dB μ V/m)	Limits (dB μ V/m)
2389.15	H	35.23	54
2483.67	H	37.36	54

Frequency (MHz)	Antenna Polarization	Emission Read Value (dB μ V/m)	Limits (dB μ V/m)
2389.15	V	30.12	54
2483.67	V	31.42	54

Conducted test result
CH Low

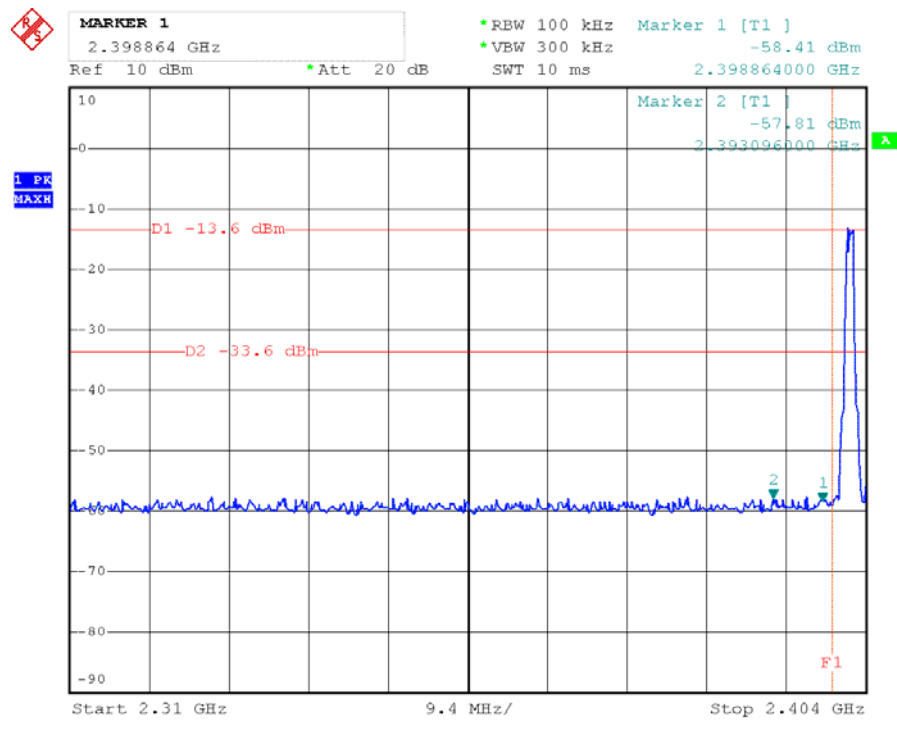

CH High

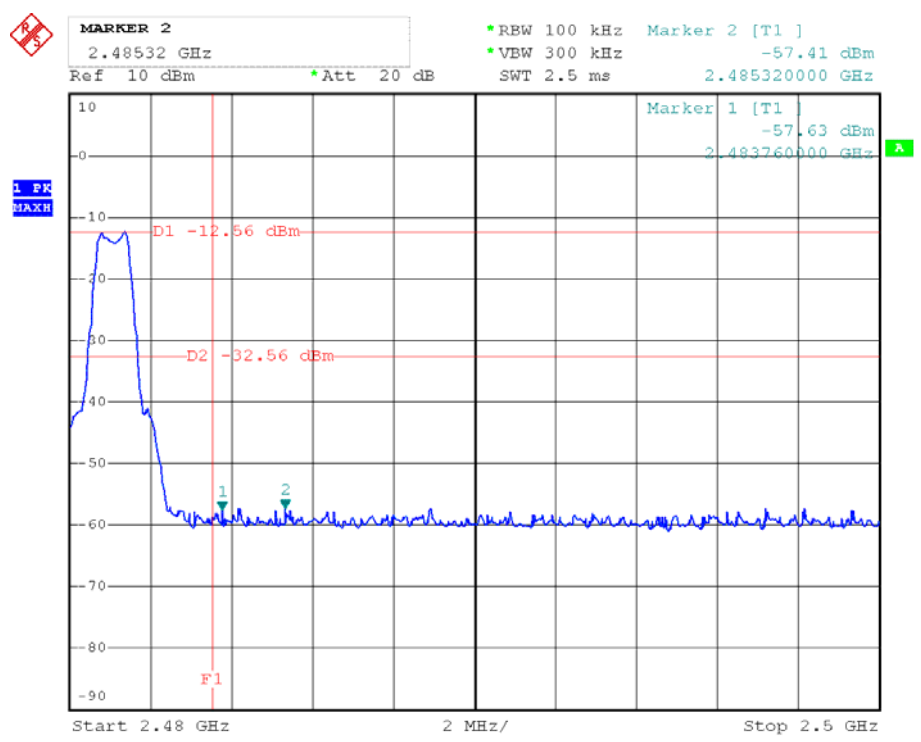

7. SPURIOUS EMISSIONS

7.1 Limit of Spurious Emissions

1. In the section 15.249(a): Except as provided in paragraph (b) of this section, the field strength of emissions from intentional radiators operated within these frequency bands shall comply with the following:
2. Except as provided elsewhere in this Subpart, the emissions from an intentional radiator shall not exceed the field strength levels specified in the following table:

Fundamental Frequency (MHz)	Field Strength of Fundamental Field Strength (mV/m)	Field Strength of Harmonics ($\mu\text{V/m}$)
902-928 MHz	50	500
2400 - 2483.5 MHz	50	500
5725 - 5875 MHz	50	500
24.0 - 24.25 GHz	250	2500

Frequency (MHz)	Field Strength ($\mu\text{V/m}$)	Measurement Distance (m)
30-88	100*	3
88-216	150*	3
216-960	200*	3
Above 960	500	3

Remark: Except as provided in paragraph (g), fundamental emissions from intentional radiators operating under this Section shall not be located in the frequency bands 54-72 MHz, 76-88 MHz, 174-216 MHz or 470-806 MHz. However, operation within these frequency bands is permitted under other sections of this Part, e.g., Sections 15.231 and 15.241.

3. In the above emission table, the tighter limit applies at the band edges.

Frequency (MHz)	Field Strength ($\mu\text{V/m}$ at 3-meter)	Field Strength (dB $\mu\text{V/m}$ at 3-meter)
30-88	100	40
88-216	150	43.5
216-960	200	46
Above 960	500	54

7.2 EUT Setup

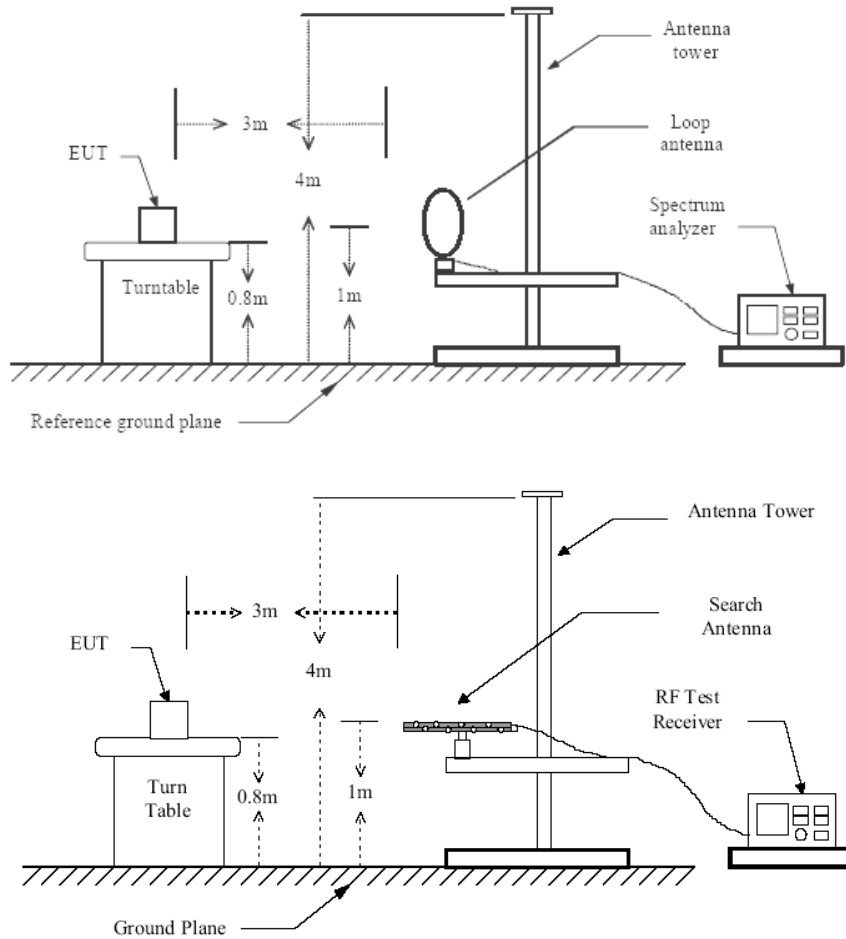

Figure 1 : Frequencies measured below 1 GHz configuration

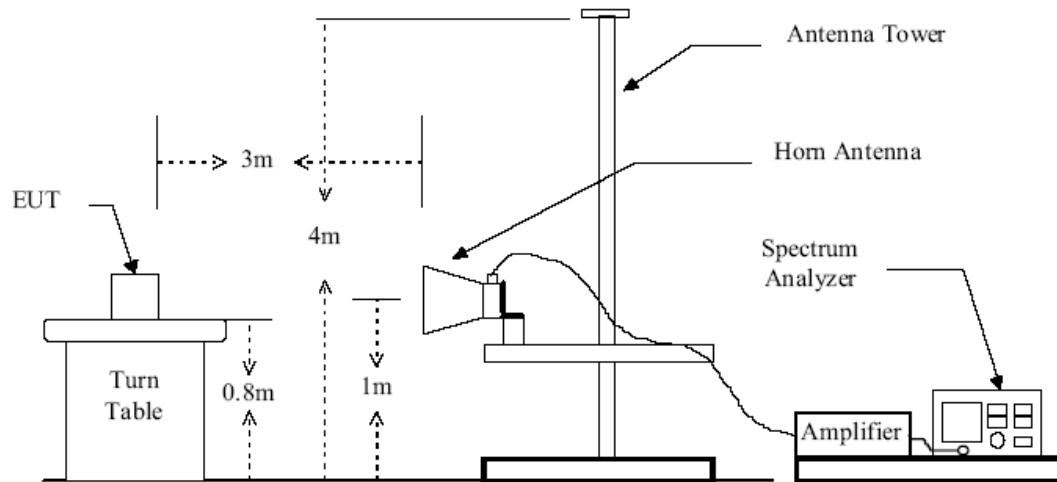

Figure 2 : Frequencies measured above 1 GHz configuration

7.3 Test Procedure

Maximizing procedure was performed on the highest emissions to ensure that the EUT complied with all installation combinations.

- 1). Configure the EUT according to ANSI C63.10:2013.
- 2). The EUT was placed on the top of the turntable 0.8m(Below 1GHz),1.5m(Above 1GHz) above ground.
- 3). The receiving antenna was placed 3 meters far away from the turntable.
- 4). The turntable was rotated by 360 degrees to determine the position of the highest radiation.
- 5). The height of the broadband receiving antenna was varied between one meter and four meters above ground to find the maximum emission field strength of both horizontal and vertical polarization. For each suspected emission, the antenna tower was scanned (from 1 M to 4 M) and then the turntable was rotated (from 0 degree to 360 degrees) to find the maximum reading.

7.4 Spurious Emissions Test Result

Normal operating Mode:

Frequency	Meter Reading	Antenna Factor	Cable Loss	Emission Levels	Limits	Margin	Detector Mode
(MHz)	(dB μ V)	(dB/M)	(dB)	(dB μ V/M)	(dB μ V/M)	(dB)	PK/QP
0.48	22.38	8.25	1.01	28.62	67	-38.38	QP
16.89	21.75	7.57	1.2	27.12	49.5	-22.38	QP
24.46	23.24	8.64	1.05	31.83	49.5	-17.67	QP
26.07	23.63	7.22	1.69	28.16	49.5	-21.34	QP

Note: In this testing, the EUT was respectively tested in three different orientations. That is:

1. EUT was lie vertically, and then its Antenna oriented upward
2. EUT was lie vertically, and then its Antenna oriented downward
3. EUT was lie flatwise, and then its Antenna oriented to the receiving antenna

The worst Spurious Emission Data Below 1GHz Channel Low:

SWEEP TABLE: "test (30M-1G)"

Short Description:		Field Strength			
Start Frequency	Stop Frequency	Detector	Meas. Time	IF Bandw.	Transducer
30.0 MHz	1.0 GHz	MaxPeak	Coupled	100 kHz	VULB9163 NEW

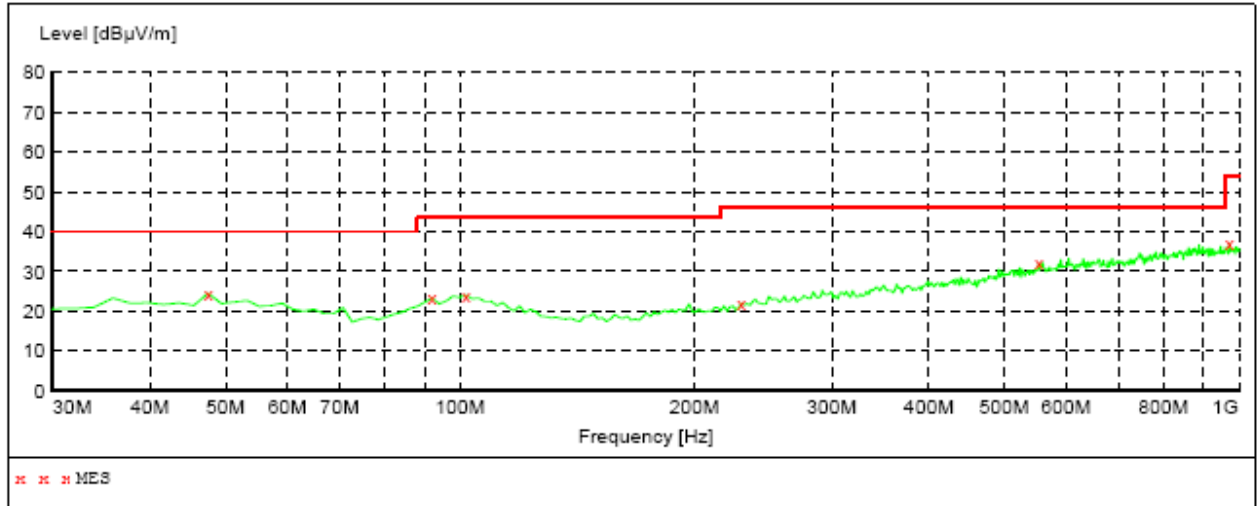

MEASUREMENT RESULT:

Frequency MHz	Level dBµV/m	Transd dB	Limit dBµV/m	Margin dB	Det.	Height cm	Azimuth deg	Polarization
47.460000	24.50	15.8	40.0	15.5	QP	100.0	0.00	HORIZONTAL
92.080000	23.30	16.5	43.5	20.2	QP	100.0	0.00	HORIZONTAL
101.780000	24.10	17.3	43.5	19.4	QP	100.0	0.00	HORIZONTAL
229.820000	22.00	16.1	46.0	24.0	QP	100.0	0.00	HORIZONTAL
553.800000	32.00	25.1	46.0	14.0	QP	100.0	0.00	HORIZONTAL
972.840000	36.90	29.7	54.0	17.1	QP	100.0	0.00	HORIZONTAL

SWEEP TABLE: "test (30M-1G)"

Short Description:		Field Strength			
Start	Stop	Detector	Meas. Time	IF Bandw.	Transducer
Frequency	Frequency				
30.0 MHz	1.0 GHz	MaxPeak	Coupled	100 kHz	VULB9163 NEW

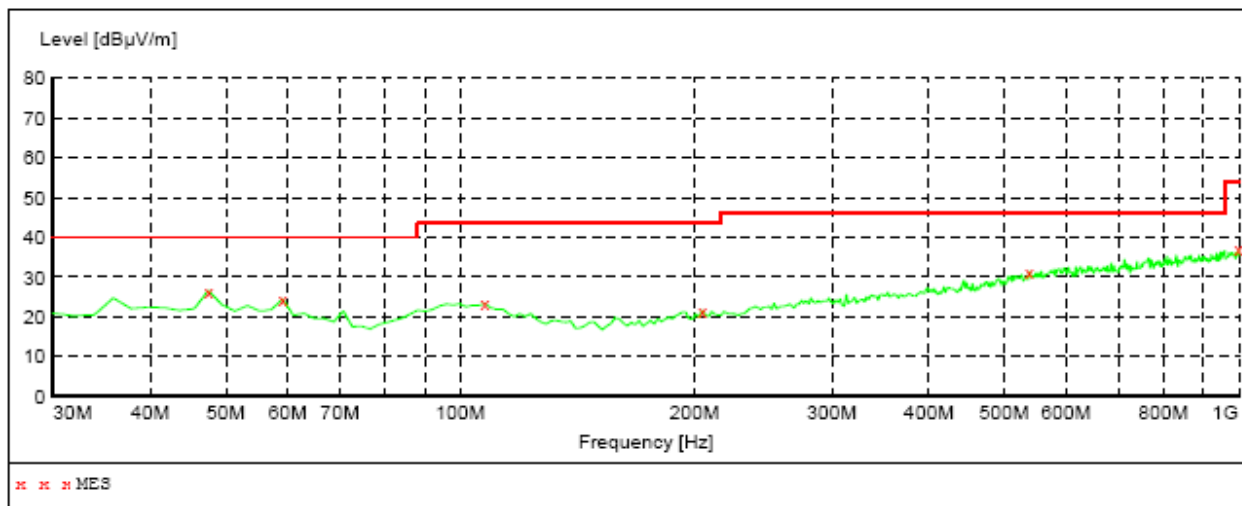

MEASUREMENT RESULT:

Frequency MHz	Level dBµV/m	Transd dB	Limit dBµV/m	Margin dB	Det.	Height cm	Azimuth deg	Polarization
47.460000	26.60	15.8	40.0	13.4	QP	100.0	0.00	VERTICAL
59.100000	24.50	14.6	40.0	15.5	QP	100.0	0.00	VERTICAL
107.600000	23.30	16.8	43.5	20.2	QP	100.0	0.00	VERTICAL
204.600000	21.60	15.0	43.5	21.9	QP	100.0	0.00	VERTICAL
538.280000	31.40	24.7	46.0	14.6	QP	100.0	0.00	VERTICAL
1000.000000	36.90	30.0	54.0	17.1	QP	100.0	0.00	VERTICAL

The worst Spurious Emission Data above 1GHz Channel Low

Channel Low (2402MHz)								
Maximum Frequency (MHz)	Polarity and Level					Limit (dBµV/m)	Margin (dBµV/m)	Mark (P/Q/A)
	Polarity	Height (m)	Reading dBµV	Transd	Result dBµV/m			
2402	H	1	92.45	-7.15	85.3	114	-28.7	P
			84.52	-7.15	77.37	94	-16.63	A
2402	V	1	98.34	-7.15	91.19	114	-22.81	P
			89.25	-7.15	82.1	94	-11.9	A
4804	H	1	41.78	1.07	42.85	74	-31.15	P
			31.52	1.07	32.59	54	-21.41	A
4804	V	1	43.75	1.07	44.82	74	-29.18	P
			32.85	1.07	33.92	54	-20.08	A
7206	H	1	41.68	7.38	49.06	74	-24.94	P
			32.22	7.38	39.6	54	-14.4	A
7206	V	1	43.05	7.38	50.43	74	-23.57	P
			32.89	7.38	40.27	54	-14.09	A
9608	H	1	----	----	----	----	----	P
			----	----	----	----	----	A
9608	V	1	----	----	----	----	----	P
			----	----	----	----	----	A
12021.67	H	1	----	----	----	----	----	P
			----	----	----	----	----	A
12021.67	V	1	----	----	----	----	----	P
			----	----	----	----	----	A
25380.37	----	----	----	----	----	----	----	----

Remark: 1. Transd.=Antenna Factor+Cable Loss-Pre-amplifier
 Margin = Level-Limit
 Mark: P means Peak Value, Q means Quasi Peak Value, A means Average Value
 2. Data of measurement within this frequency range shown “-” in the table above means the reading of emissions are attenuated more than 20dB below the permissible limits or the field strength is too small to be measured.
 3. Spectrum analyzer setting P(Peak): RBW=1MHz, VBW=1MHz, A(Average): RBW=1MHz, VBW=10Hz.
 4. The test limit distance is 3m limit

The worst Spurious Emission Data above 1GHz Channel Middle

Channel Low (2441MHz)								
Maximum Frequency (MHz)	Polarity and Level					Limit (dBµV/m)	Margin (dBµV/m)	Mark (P/Q/A)
	Polarity	Height (m)	Reading dBµV	Transd	Result dBµV/m			
2441	H	1	90.23	-6.37	83.86	114	-30.14	P
			82.15	-6.37	75.78	94	-18.22	A
2441	V	1	96.34	-6.37	89.97	114	-24.03	P
			85.68	-6.37	79.31	94	-14.69	A
4882	H	1	41.27	1.07	42.34	74	-31.66	P
			32.07	1.07	33.14	54	-20.86	A
4882	V	1	43.64	1.07	44.71	74	-29.29	P
			32.49	1.07	33.56	54	-20.44	A
7323	H	1	41.52	7.49	49.01	74	-24.99	P
			32.09	7.49	39.58	54	-14.42	A
7323	V	1	43.43	7.49	50.92	74	-23.08	P
			32.52	7.49	40.01	54	-13.99	A
9755	H	1	----	----	----	----	----	P
			----	----	----	----	----	A
9755	V	1	----	----	----	----	----	P
			----	----	----	----	----	A
12191.67	H	1	----	----	----	----	----	P
			----	----	----	----	----	A
12191.67	V	1	----	----	----	----	----	P
			----	----	----	----	----	A
25380.37	----	----	----	----	----	----	----	----

Remark: 1. Transd.=Antenna Factor+Cable Loss-Pre-amplifier
 Margin = Level-Limit
 Mark: P means Peak Value, Q means Quasi Peak Value, A means Average Value
 2. Data of measurement within this frequency range shown “-” in the table above means the reading of emissions are attenuated more than 20dB below the permissible limits or the field strength is too small to be measured.
 3. Spectrum analyzer setting P(Peak): RBW=1MHz, VBW=1MHz, A(Average): RBW=1MHz, VBW=10Hz.
 4. The test limit distance is 3m limit

The worst Spurious Emission Data above 1GHz Channel High

Channel Low (2481MHz)								
Maximum Frequency (MHz)	Polarity and Level					Limit (dBµV/m)	Margin (dBµV/m)	Mark (P/Q/A)
	Polarity	Height (m)	Reading dBµV	Transd	Result dBµV/m			
2480	H	1	90.85	-6.05	84.8	114	-29.2	P
			82.43	-6.05	76.38	94	-17.62	A
2480	V	1	96.25	-6.05	90.2	114	-23.8	P
			85.09	-6.05	79.04	94	-14.96	A
4960	H	1	41.78	1.07	42.85	74	-31.15	P
			32.54	1.07	33.61	54	-20.39	A
4960	V	1	43.39	1.07	44.46	74	-29.54	P
			32.28	1.07	33.35	54	-20.65	A
7440	H	1	41.06	7.61	48.67	74	-25.33	P
			32.57	7.61	40.18	54	-13.82	A
7440	V	1	43.43	7.61	51.04	74	-22.96	P
			32.35	7.61	39.96	54	-14.04	A
9924	H	1	----	----	----	----	----	P
			----	----	----	----	----	A
9924	V	1	----	----	----	----	----	P
			----	----	----	----	----	A
12361.67	H	1	----	----	----	----	----	P
			----	----	----	----	----	A
12361.67	V	1	----	----	----	----	----	P
			----	----	----	----	----	A
25380.37	----	----	----	----	----	----	----	----

Remark: 1. Transd.=Antenna Factor+Cable Loss-Pre-amplifier
 Margin = Level-Limit
 Mark: P means Peak Value, Q means Quasi Peak Value, A means Average Value
 2. Data of measurement within this frequency range shown “-” in the table above means the reading of emissions are attenuated more than 20dB below the permissible limits or the field strength is too small to be measured.
 3. Spectrum analyzer setting P(Peak): RBW=1MHz, VBW=1MHz, A(Average): RBW=1MHz, VBW=10Hz.
 4. The test limit distance is 3m limit

8. ANTENNA REQUIREMENT

8.1 Standard Applicable

Section 15.203:

An intentional radiator shall be designed to ensure that no antenna other than that furnished by the responsible party shall be used with the device. The use of a permanently attached antenna or of an antenna that uses a unique coupling to the intentional radiator shall be considered sufficient to comply with the provisions of this Section. The manufacturer may design the unit so that a broken antenna can be replaced by the user, but the use of a standard antenna jack or electrical connector is prohibited.

8.2 Antenna Connected Construction

The antenna connector is designed with permanent attachment and no consideration of replacement.