

1. FCC/IC Label design and location (YFGW520)

Main name plate

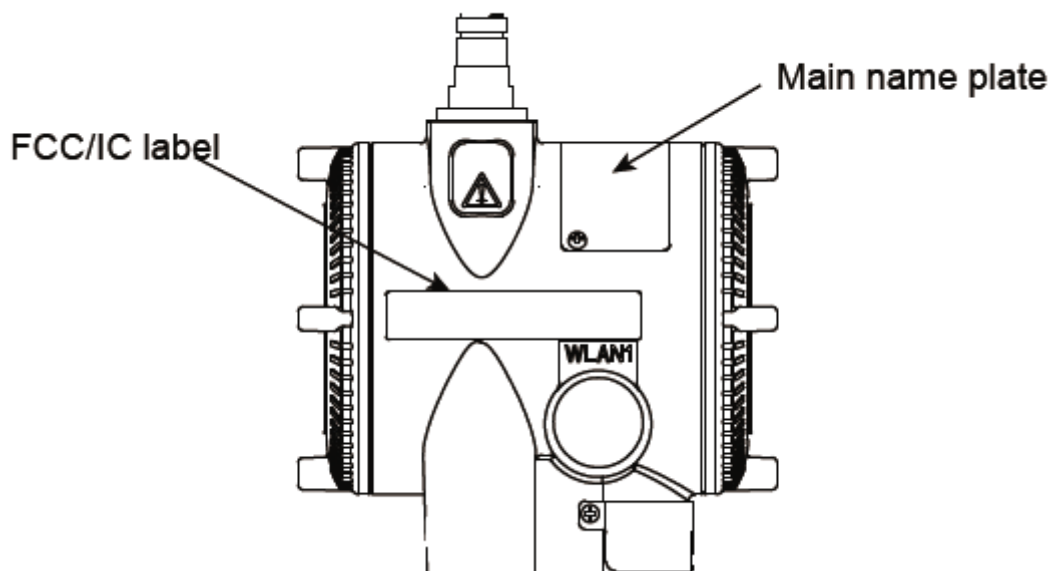

FCC/IC Label

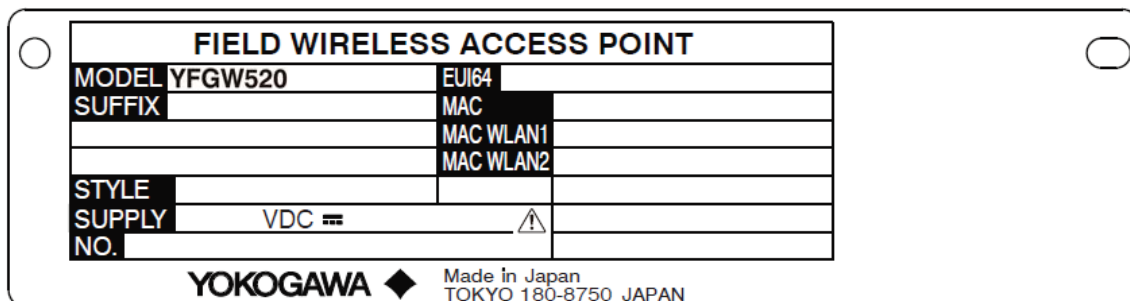