

User's Manual

WLAN Redundant Module F9195KJ

1. Description

F9195KJ WLAN Redundant Module is a dual-band (2.4GHz/5GHz) wireless LAN client with redundant WLAN chip module in accordance with IEEE 802.11b/g/a.



2. General Specification

Table1 General Specification

Item	Specification
System Clock	40MHz (Reference Clock)
Operating Power supply	DC 5.0V
Operating Temperature	-40 To +70deg. C.

3. Radio Specification

Table2 Radio Specification

Item	Specification
Equipment type	Transceiver
Frequency of operation	IEEE802.11b/g: 2412 to 2462MHz IEEE802.11a: 5180 to 5825MHz
Bandwidth / Channel spacing	IEEE802.11b/g: 22MHz / 5MHz IEEE802.11a: 20MHz / 20MHz
Type of modulation	IEEE802.11b: DSSS IEEE802.11g: DSSS/OFDM IEEE802.11a: OFDM
Antenna type	Sleeve antenna(2.14dBi), Collinear antenna(6dBi, 9dBi), Patch antenna(15dBi)
Antenna connector type	Hirose H.FL unique connector. And the installation and replacement of antenna are done by professionals as directed in the user's manual.
Antenna gain with cable loss	+2.14dBi, +6.00dBi, +9.00dBi,+15.00dBi
ITU code	G1D, D1D

4. Block Diagram

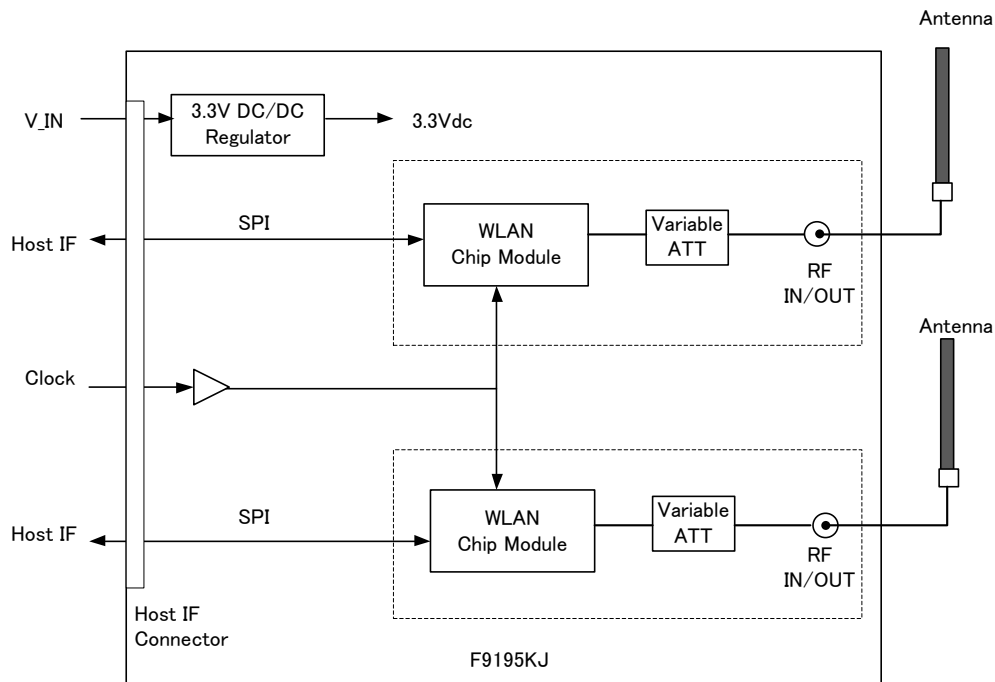

Figure1 System Block Diagram

5. Theory of operation

5.1. Power Supply

The primary power supply input V_IN is supplied via the host interface connector. The Usable input voltage range for V_IN is 4.5Vdc to 5.5Vdc. This Module have 3.3V DC/DC regulator which convert from 5Vdc to regulated 3.3Vdc. The 3.3V DC/DC regulator supplies a regulated 3.3Vdc to the RF circuitry include WLAN Chip module and the other logic ICs.

5.2. Clock

The 40MHz external clock is provided via the host interface connector.

5.3. WLAN Chip Module

The WLAN Chip Module is a single package device that contains dual band (2.4GHz/5GHz) IEEE802.11b/g/a client function with a SPI interface to a host processor. It integrates a MAC, Baseband processor, dual band RF transceiver with power amplifier and diplexer and all WLAN protocols.

5.4. WLAN Redundancy Feature

- After startup, only the primary WLAN chip module starts operating.
- While the primary WLAN chip module is operating, the host processor checks the RSSI (Received Signal Strength Indicator) of the primary WLAN chip module via the host SPI.
- If the RSSI value becomes lower than the certain level, the host processor changes the operating module from the primary WLAN chip module to the secondary WLAN module via the host SPI.

6. FCC Compliance

WLAN Redundant Module F9195KJ has been certified per FCC Part 15 rules for integration into products without further testing or certification. To fulfill the FCC certification requirements, the final product manufacture using F9195KJ module must ensure that the information provided on the F9195KJ module label is placed on the outside of the final product. F9195KJ module is labeled with its own FCC ID Number. If the FCC ID is not visible when the module is installed inside another product, then the outside of the product into which the module is installed must also display a label referring to enclosed module. This exterior label can use wording such as the following:

Contains Transmitter Module FCC ID: SGJ-WFC009

This device complies with part 15 of the FCC Rules. Operation is subject to the following two conditions: (1) This device may not cause harmful interference, and (2) this device must accept any interference received, including interference that may cause undesired operation.

The final product manufacture using the F9195KJ module must only use the approved antenna that has been certified with this module.

FCC approved Antenna

Model Name	Specification
MTA-11DAD2-YO	+2.14dBi Sleeve antenna 2.4GHz/5GHz
ASCL-NP-00400	+2.14dBi Sleeve antenna 2.4GHz
ASCL-NP-00200	+6.0dBi Collinear antenna 2.4GHz
ASCL-NP-00300	+9.0dBi Collinear antenna 2.4GHz
MTA-11PA15-Y0	+15dBi Patch antenna 2.4GHz

Co-Located:

This transmitter must not be co-located or operated in conjunction with any other antenna or transmitter.

FCC CAUTION

Changes or modifications not expressly approved by the party responsible for compliance could void the user's authority to operate the equipment.

Note: This equipment has been tested and found to comply with the limits for a Class A digital device, pursuant to part 15 of the FCC Rules. These limits are designed to provide reasonable protection against harmful interference when the equipment is operated in a commercial environment. This equipment generates, uses, and can radiate radio frequency energy and, if not installed and used in accordance with the instruction manual, may cause harmful interference to radio communications. Operation of this equipment in a residential area is likely to cause harmful interference in which case the user will be required to correct the interference at his own expense.

Compliance with FCC requirement 15.407(c)

Data transmission is always initiated by software, which is the passed down through the MAC, through the digital and analog baseband, and finally to the RF chip. Several special packets are initiated by the MAC. These are the only ways the digital baseband portion will turn on the RF transmitter, which it then turns off at the end of the packet. Therefore, the transmitter will be on only while one of the aforementioned packets is being transmitted. In other words, this device automatically discontinue transmission in case of either absence of information to transmit or operational failure.

5GHz band Frequency Tolerance: 20 ppm

RF Exposure Compliance

This equipment complies with FCC radiation exposure limits set forth for an uncontrolled environment and meets the FCC radio frequency (RF) Exposure Guidelines. This equipment should be installed and operated keeping the radiator at least 20cm or more away from person's body.

7. Industry Canada (IC) Compliance

Labeling requirements for Industry Canada are similar to those of the FCC. A clearly visible label on the outside of the final product enclosure must display the following text:

Contains IC: 8999A-WIC008

This device complies with Industry Canada's licence-exempt RSSs. Operation is subject to the following two conditions:

- (1) This device may not cause interference; and
- (2) This device must accept any interference, including interference that may cause undesired operation of the device.

French: Le présent appareil est conforme aux CNR d'Industrie Canada applicables aux appareils radio exempts de licence. L'exploitation est autorisée aux deux conditions suivantes :

- (1) l'appareil ne doit pas produire de brouillage;
- (2) l'utilisateur de l'appareil doit accepter tout brouillage radioélectrique subi, même si le brouillage est susceptible d'en compromettre le fonctionnement.

This radio transmitter IC Number 8999A-WIC008 has been approved by Industry Canada to operate with the antenna types listed below with the maximum permissible gain indicated. Antenna types not included in this list, having a gain greater than the maximum gain indicated for that type, are strictly prohibited for use with this device.

Antenna type:	Gain:	Antenna type:	Gain:
Sleeve	2.14dBi, 50Ω	Collinear	9dBi, 50Ω
Collinear	6dBi, 50Ω	Patch compound	15dBi, 50Ω

French: Le présent émetteur radio IC Number 8999A-WIC008 a été approuvé par Industrie Canada pour fonctionner avec les types d'antenne énumérés ci-dessous et ayant un gain admissible maximal. Les types d'antenne non inclus dans cette liste, et dont le gain est supérieur au gain maximal indiqué, sont strictement interdits pour l'exploitation de l'émetteur.

Antenna type:	Gain:	Antenna type:	Gain:
Sleeve	2.14dBi, 50Ω	Collinear	9dBi, 50Ω
Collinear	6dBi, 50Ω	Patch compound	15dBi, 50Ω

5150-5350 MHz band is restricted to indoor operation only.

French: La bande 5150-5350 MHz est restreinte à une utilisation à l'intérieur seulement.

Data transmission is always initiated by software, which is then passed down through the MAC, through the digital and analog baseband, and finally to the RF chip. Several special packets are initiated by the MAC. These are the only ways the digital baseband portion will turn on the RF transmitter, which it then turns off at the end of the packet. Therefore, the transmitter will be on only while one of the aforementioned packets is being transmitted. In other words, this device automatically discontinues transmission in case of either absence of information to transmit or operational failure.

French: La transmission des données est toujours initiée par le logiciel, puis les données sont transmises par l'intermédiaire du MAC, par la bande de base numérique et analogique et, enfin, à la puce RF. Plusieurs paquets spéciaux sont initiés par le MAC. Ce sont les seuls moyens pour qu'une partie de la bande de base numérique active l'émetteur RF, puis désactive celui-ci à la fin du paquet. En conséquence, l'émetteur reste uniquement activé lors de la transmission d'un des paquets susmentionnés. En d'autres termes, ce dispositif interrompt automatiquement toute transmission en cas d'absence d'information à transmettre ou de défaillance.

RF Exposure Compliance:

This equipment complies with IC radiation exposure limits set forth for an uncontrolled environment and meets RSS-102 of the IC radio frequency (RF) Exposure rules. This equipment should be installed and operated keeping the radiator at least 20cm or more away from person's body.

French: Cet équipement est conforme aux limites d'exposition aux rayonnements énoncées pour un environnement non contrôlé et respecte les règles d'exposition aux fréquences radioélectriques (RF) CNR-102 de l'IC. Cet équipement doit être installé et utilisé en gardant une distance de 20 cm ou plus entre le radiateur et le corps humain.