



# FCC SAR TEST REPORT

**Report No.:** SET2016-17164  
**Product:** Smartphone  
**Brand Name:** Haier  
**Model No.:** HM-G551-FL, L54  
**FCC ID:** SG7201609G551  
**Applicant:** Haier Telecom(Qingdao) CO., Ltd.  
**Address:** No1.Haier Road,Hi-tech Zone Qingdao,China  
**Issued by:** CCIC-SET  
**Lab Location:** Building 28/29, East of Shigu, Xili Industrial Zone, Xili Road, Nanshan District, Shenzhen, Guangdong, China  
**Tel:** 86 755 26627338      **Fax:** 86 755 26627238  
**Mail:** manager@ccic-set.com      **Website:** <http://www.ccic-set.com>

This test report consists of **150** pages in total. It may be duplicated completely for legal use with the approval of the applicant. It should not be reproduced except in full, without the written approval of our laboratory. The client should not use it to claim product endorsement by CCIC-SET. The test results in the report only apply to the tested sample. The test report shall be invalid without all the signatures of testing engineers, reviewer and approver. Any objections must be raised to CCIC-SET within 15 days since the date when the report is received. It will not be taken into consideration beyond this limit.



# Test Report

**Product** .....: Smartphone  
**Model No.** .....: HM-G551-FL, L54  
**Brand Name**.....: Haier  
**FCC ID**.....: SG7201609G551  
**Applicant**.....: Haier Telecom(Qingdao) CO., Ltd.  
**Applicant Address**.....: No1.Haier Road,Hi-tech Zone Qingdao,China  
**Manufacturer**.....: Haier Telecom(Qingdao) CO., Ltd.  
**Manufacturer Address**: No1.Haier Road,Hi-tech Zone Qingdao,China

**Test Standards**.....: **47CFR § 2.1093-** Radiofrequency Radiation Exposure Evaluation: Portable Devices;  
**ANSI C95.1-1992:** Safety Levels with Respect to Human Exposure to Radio Frequency Electromagnetic Fields, 3 kHz – 300 GHz.( IEEE Std C95.1-1991)  
**IEEE 1528-2013:** IEEE Recommended Practice for Determining the Peak Spatial-Average Specific Absorption Rate (SAR) in the Human Head from Wireless Communications Devices: Measurement Techniques

**Test Result**.....: Pass

**Tested by** .....: Mei Chun 2016-09-23  
 Chun Mei, Test Engineer

**Reviewed by**.....: Shuangwen Zhang 2016-09-23  
 Shuangwen Zhang, Senior EGINEER

**Approved by**.....: Wu Lian 2016-09-23  
 Wu Li'an , Manager



# Contents

- 1. **GENERAL CONDITIONS**-----4
- 2. **ADMINISTRATIVE DATA**-----5
  - 2.1. Identification of the Responsible Testing Laboratory-----5
  - 2.2. Identification of the Responsible Testing Location(s)-----5
  - 2.3. Organization Item-----5
  - 2.4. Identification of Applicant-----5
  - 2.5. Identification of Manufacture-----5
- 3. **EQUIPMENT UNDER TEST (EUT)**-----6
- 4. **SAR SUMMAY**-----7
- 5. **Specific Absorption Rate(SAR)**-----8
  - 5.1. Introduction-----8
  - 5.2. SAR Definition-----8
  - 5.3. Phantoms-----9
  - 5.4. Device Holder-----9
  - 5.5. Probe Specification-----10
- 6. **OPERATIONAL CONDITIONS DURING TEST**-----11
  - 6.1. Schematic Test Configuration-----11
  - 6.2. SAR Measurement System-----11
  - 6.3. Equipments and results of validation testing-----14
  - 6.4. SAR measurement procedure-----16
  - 6.5. Antennas position and test position-----18
- 7. **CHARACTERISTICS OF THE TEST**-----19
  - 7.1. Applicable Limit Regulations-----19
  - 7.2. Applicable Measurement Standards-----19
- 8. **LABORATORY ENVIRONMENT**-----19
- 9. **CONDUCTED RF OUTPUT POWER**-----20
- 10. **TEST RESULTS**-----36
- 11. **MEASUREMENT UNCERTAINTY**-----50
- 12. **MAIN TEST INSTRUMENTS**-----53

**This Test Report consists of the following Annexes:**

<b>Annex A: Test Layout</b> -----	47
<b>Annex B: Sample Photographs</b> -----	50
<b>Annex C: System Performance Check Data and Highest SAR Plots</b> -----	52
<b>Annex D: Calibration Certificate of Probe and Dipoles</b> -----	81



## **1. GENERAL CONDITIONS**

**1.1 This report only refers to the item that has undergone the test.**

**1.2 This report standalone does not constitute or imply by its own an approval of the product by the certification Bodies or competent Authorities.**

**1.3 This document is only valid if complete; no partial reproduction can be made without written approval of CCIC-SET**

**1.4 This report cannot be used partially or in full for publicity and/or promotional purposes without previous written approval of CCIC-SET and the Accreditation Bodies, if it applies.**



## 2. Administrative Date

### 2.1. Identification of the Responsible Testing Laboratory

**Company Name:** CCIC-SET

**Department:** EMC & RF Department

**Address:** Building 28/29, East of Shigu, Xili Industrial Zone, Xili Road,  
Nanshan District, Shenzhen, Guangdong, China

**Telephone:** +86-755-26629676

**Fax:** +86-755-26627238

**Responsible Test Lab  
Managers:** Mr. Wu Li'an

### 2.2. Identification of the Responsible Testing Location(s)

**Company Name:** CCIC-SET

**Address:** Building 28/29, East of Shigu, Xili Industrial Zone, Xili Road,  
Nanshan District, Shenzhen, Guangdong, China

### 2.3. Organization Item

**CCIC-SET Report No.:** SET2016-17164

**CCIC-SET Project Leader:** Mr. Li Sixiong

**CCIC-SET Responsible  
for accreditation scope:** Mr. Wu Li'an

**Start of Testing:** 2016-09-05

**End of Testing:** 2016-09-11

### 2.4. Identification of Applicant

**Company Name:** Haier Corporation

**Address:** Haier Plaza, Keji Road South, Shenzhen, China

### 2.5. Identification of Manufacture

**Company Name:** Haier Corporation

**Address:** Haier Plaza, Keji Road South, Shenzhen, China

**Notes:** This data is based on the information by the applicant.

### 3. Equipment Under Test (EUT)

#### 3.1. Identification of the Equipment under Test

**Sample Name:** Smartphone

**Model Name:** HM-G551-FL, L54

**Brand Name:** Haier

<b>General description:</b>	Support Band	GSM850MHz/1900MHz/900MHz/1800MHz WCDMA 850MHz/1900MHz, LTE Band4/5/7,WIFI, BT
	Test Band	GSM 850MHz/ GSM 1900MHz, GPRS 850MHz/ GPRS 1900MHz, WCDMA 850MHz /1900MHz, LTE Band4/5/7,WIFI 802.11b
	Multislot Class	GPRS: Class 12; EGPRS: Class 12
	GPRS Class	Class B
	Development Stage	Identical Prototype
	Accessories	Power Supply
	Battery type	2000mAh
	Antenna type	Inner Antenna
	Operation mode	GSM / GPRS /WCDMA / LTE /WIFI
	Modulation mode	GSM(GMSK),UMTS(QPSK),LTE(QPSK,16QAM), WIFI(OFDM/DSSS)
	Max. RF Power	32.82dBm
	Max. SAR Value	Head: 0.467W/kg; Body-Worn: 1.024W/kg; Hotspot: 1.024W/kg (10mm distance)

**NOTE:**

- a. The above EUT's information was declared by manufacturer. Please refer to the specifications or user's manual for more detailed description.
- b. This device supports GPRS operation up to class12 (max.uplin:4, max.downlink:4, total timeslots:5). This device supports EDGE operation up to class12(max.uplin:4, max.downlink:4, total timeslots:5)



## 4 SAR SUMMARY

### Highest Standalone SAR Summary

Exposure Position	Frequency Band	Scaled 1g-SAR(W/kg)	Highest Scaled 1g-SAR(W/kg)
Head	GSM850	0.313	0.467
	GSM1900	0.245	
	WCDMA Band V	0.235	
	WCDMA Band II	0.467	
	LTE Band 4	0.229	
	LTE Band 5	0.187	
	LTE Band 7	0.254	
	WIFI	0.406	
Body-worn Accessory (10mm Gap)	GSM850	0.413	1.024
	GSM1900	0.537	
	WCDMA Band V	0.357	
	WCDMA Band II	1.024	
	LTE Band 4	0.357	
	LTE Band 5	0.245	
	LTE Band 7	0.707	
	WIFI	0.179	
Hotspot (10mm Gap)	GSM850	0.552	1.024
	GSM1900	0.675	
	WCDMA Band V	0.357	
	WCDMA Band II	1.024	
	LTE Band 4	0.357	
	LTE Band 5	0.245	
	LTE Band 7	0.707	
	WIFI	0.179	

## Highest Simultaneous SAR Summary

Exposure Position	Frequency Band	Highest Scaled 1g-SAR(W/kg)
Head	WWAN(WCDMA1900)&WIFI	0.729
Body-worn (10mmGap)	WWAN(WCDMA1900)&WIFI	1.203
Hotspot (10mmGap)	WWAN(WCDMA1900)&WIFI	1.203

## 5 Specific Absorption Rate (SAR)

### 5.1 Introduction

SAR is related to the rate at which energy is absorbed per unit mass in an object exposed to a radio field. The SAR distribution in a biological body is complicated and is usually carried out by experimental techniques or numerical modeling. The standard recommends limits for two tiers of groups, occupational/controlled and general population/uncontrolled, based on a person's awareness and ability to exercise control over his or her exposure. In general, occupational/controlled exposure limits are higher than the limits for general population/uncontrolled.

### 5.2 SAR Definition

The SAR definition is the time derivative (rate) of the incremental energy (dW) absorbed by (dissipated in) an incremental mass (dm) contained in a volume element (dv) of a given density ( $\rho$ ). The equation description is as below:

$$\text{SAR} = \frac{d}{dt} \left( \frac{dW}{dm} \right) = \frac{d}{dt} \left( \frac{dW}{\rho dv} \right)$$

SAR is expressed in units of Watts per kilogram (W/kg)

SAR measurement can be either related to the temperature elevation in tissue by

$$\text{SAR} = C \frac{\delta T}{\delta t}$$

where C is the specific heat capacity,  $\delta T$  is the temperature rise and  $\delta t$  the exposure duration, or related to the electrical field in the tissue by

$$\text{SAR} = \frac{\sigma |E|^2}{\rho}$$

where  $\sigma$  is the conductivity of the tissue,  $\rho$  is the mass density of the tissue and E is the rms electrical field strength.

However for evaluating SAR of low power transmitter, electrical field measurement is typically applied.



### 5.3 Phantoms

The phantom used for all tests i.e. for both system checks and device testing, was the twin-headed "SAM Phantom", manufactured by SATIMO. The SAM twin phantom is a fiberglass shell phantom with 2mm shell thickness (except the ear region, where shell thickness increases to 6mm).

System checking was performed using the flat section, whilst Head SAR tests used the left and right head profile sections. Body SAR testing also used the flat section between the head profiles.



SAM Twin Phantom

### 5.4 Device Holder

The device was placed in the device holder (illustrated below) that is supplied by SATIMO as an integral part of the COMOSAR test system.

The device holder is designed to cope with the different positions given in the standard. It has two scales for device rotation (with respect to the body axis) and device inclination (with respect to the line between the ear reference points). The rotation centers for both scales is the ear reference point (ERP). Thus the device needs no repositioning when changing the angles.

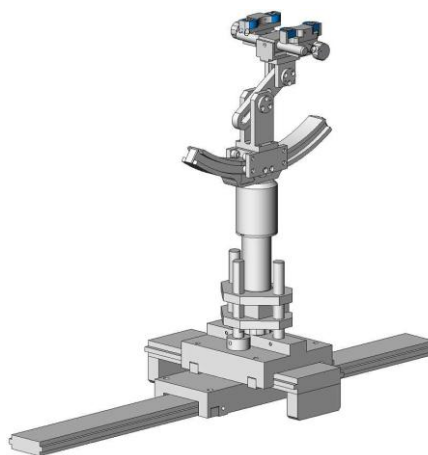

Device holder

### 5.5 Probe Specification



Construction	Symmetrical design with triangular core Interleaved sensors Built-in shielding against static charges PEEK enclosure material (resistant to organic solvents, e.g., DGBE)
Calibration	ISO/IEC 17025 calibration service available.
Frequency	700 MHz to 3 GHz; Linearity: $\pm 0.5$ dB (700 MHz to 3 GHz)
Directivity	$\pm 0.25$ dB in HSL (rotation around probe axis) $\pm 0.5$ dB in tissue material (rotation normal to probe axis)
Dynamic Range	1.5 $\mu$ W/g to 100 mW/g; Linearity: $\pm 0.5$ dB
Dimensions	Overall length: 330 mm (Tip: 20 mm) Tip diameter: 5 mm Distance from probe tip to dipole centers: <2.7 mm
Application	General dosimetry up to 3 GHz Dosimetry in strong gradient fields Compliance tests of Smartphones
Compatibility	COMOSAR

#### Isotropic E-Field Probe

The isotropic E-Field probe has been fully calibrated and assessed for isotropicity, and boundary effect within a controlled environment. Depending on the frequency for which the probe is calibrated the method utilized for calibration will change.

The E-Field probe utilizes a triangular sensor arrangement as detailed in the diagram below:

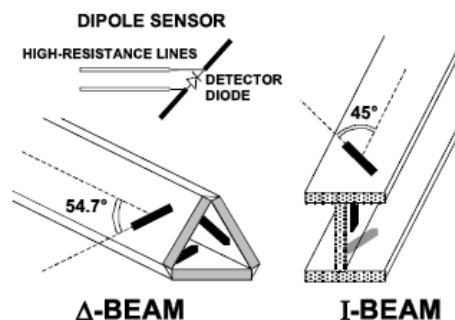

## 6 OPERATIONAL CONDITIONS DURING TEST

### 6.1 Schematic Test Configuration

During SAR test, EUT was operating in Traffic Mode (Channel Allocated) at Normal Voltage Condition. A communication link is set up with a System Simulator (SS) by air link, and a call is established. The EUT was commanded to operate at maximum transmitting power.

The EUT should use its internal transmitter. The antenna(s), battery and accessories shall be those specified by the manufacturer. The EUT battery must be fully charged and checked periodically during the test to ascertain uniform power output. If a wireless link was used, the antenna connected to the output of the base station simulator shall be placed at least 50 cm away from the handset.

The signal transmitted by the simulator to the antenna feeding point should be lower than the output power level of the handset by at least 35 dB

### 6.2 SAR Measurement System

The SAR measurement system being used is the SATIMO system, the system is controlled remotely from a PC, which contains the software to control the robot and data acquisition equipment. The software also displays the data obtained from test scans.

In operation, the system first does an area (2D) scan at a fixed depth within the liquid from the inside wall of the phantom. When the maximum SAR point has been found, the system will then carry out a 3D scan centred at that point to determine volume averaged SAR level.

#### 6.2.1 Tissue Dielectric Parameters for Head and Body Phantoms

The head tissue dielectric parameters recommended by the IEEE SCC-34/SC-2 in P1528 have been incorporated in the following table. These head parameters are derived from planar layer models simulating the highest expected SAR for the dielectric properties and tissue thickness Power drifts in a human head. Other head and body tissue parameters that have not been specified in P1528 are derived from the tissue dielectric parameters computed from the 4-Cole-Cole equations described in Reference [12] and extrapolated according to the head parameters specified in P1528.

Table 1: Recommended Dielectric Performance of Tissue

Ingredients (% by weight )	Frequency (MHz)											
	450		835		915		1900		2450		2600	
Tissue Type	Head	Body	Head	Body	Head	Body	Head	Body	Head	Body	Head	Body
Water	38.56	51.16	41.46	52.4	41.05	56.0	54.9	40.4	62.7	73.2	55.24	64.49
Salt (Nacl)	3.95	1.49	1.45	1.4	1.35	0.76	0.18	0.5	0.5	0.04	0.5	0.024
Sugar	56.32	46.78	56.0	45.0	56.5	41.76	0.0	58.0	0.0	0.0	0.0	0.0
HEC	0.98	0.52	1.0	1.0	1.0	1.21	0.0	1.0	0.0	0.0	0.0	0.0



Bactericide	0.19	0.05	0.1	0.1	0.1	0.27	0.0	0.1	0.0	0.0	0.0	0.0
Triton x-100	0.0	0.0	0.0	0.0	0.0	0.0	0.0	0.0	36.8	0.0	44.45	32.25
DGBE	0.0	0.0	0.0	0.0	0.0	0.0	44.92	0.0	0.0	26.7	0.0	26.7
Dielectric Constant	43.42	58.0	42.54	56.1	42.0	56.8	39.9	54.0	39.8	52.5	39.0	52.5
Conductivity (s/m)	0.85	0.83	0.91	0.95	1.0	1.07	1.42	1.45	1.88	1.78	1.96	2.16

MSL/HSL750 (Body and Head liquid for 650 – 850 MHz)

Item	Head Tissue Simulation Liquid HSL750 Muscle(body)Tissue Simulation Liquid MSL750			
H2O	Water, 35 – 58%			
Sucrose	Sugar, white, refined, 40-60%			
NaCl	Sodium Chloride, 0-6%			
Hydroxyethyl-cellulose	Medium Viscosity (CAS# 9004-62-0), <0.3%			
Preventol-D7	Preservative: aqueous preparation, (CAS# 55965-84-9), containing 5-chloro-2-methyl-3(2H)-isothiazolone and 2-methyl-3(2H)-isothiazolone, 0.1-0.7%			
Frequency (MHz)	Head $\epsilon_r$	Head $\sigma$ (S/m)	Body $\epsilon_r$	Body $\sigma$ (S/m)
750	41.9	0.89	55.2	0.97

Note: The liquid of 700MHz&2600MHz typical liquid composition is provided by SATIMO.

Table 2 Recommended Tissue Dielectric Parameters

Frequency (MHz)	Head Tissue		Body Tissue	
	$\epsilon_r$	$\sigma$ (S/m)	$\epsilon_r$	$\sigma$ (S/m)
150	52.3	0.76	61.9	0.80
300	45.3	0.87	58.2	0.92
450	43.5	0.87	56.7	0.94
835	41.5	0.90	55.2	0.97
900	41.5	0.97	55.0	1.05
915	41.5	0.98	55.0	1.06
1450	40.5	1.20	54.0	1.30
1610	40.3	1.29	53.8	1.40
1800-2000	40.0	1.40	53.3	1.52
2450	39.2	1.80	52.7	1.95
3000	38.5	2.40	52.0	2.73
5800	35.3	5.27	48.2	6.00

### 6.2.2 Simulate liquid

For measurements against the phantom head, the “cheek” and “tilt” position on both the left hand and the right hand sides of the phantom. For body-worn measurements, the EUT was tested against flat phantom representing the user body. The EUT was put on in the belt holder. Stimulate liquid that are used for testing at frequencies of GSM 850MHz/1900MHz, WCDMA850MHz/1700MHz/1900MHz, LTE Band2/4/5/7 and Wi-Fi 2.4GHz, which are made mainly of sugar, salt and water solutions may be left in the phantoms.

Table 3: Dielectric Performance of Head Tissue Simulating Liquid

Temperature: 23.2°C; Humidity: 64%;			
/	Frequency	Permittivity $\epsilon$	Conductivity $\sigma$ (S/m)
Target value	850MHz	$41.5 \pm 5\%$	$0.90 \pm 5\%$
Validation value (Sep. 9th, 2016)	850MHz	41.39	0.89
Target value	1800 MHz	$40.0 \pm 5\%$	$1.40 \pm 5\%$
Validation value (Sep. 10th, 2016)	1800 MHz	39.72	1.39
Target value	1900MHz	$40.0 \pm 5\%$	$1.40 \pm 5\%$
Validation value (Sep. 10th, 2016)	1900MHz	39.92	1.39
Target value	2450MHz	$39.2 \pm 5\%$	$1.80 \pm 5\%$
Validation value (Sep. 11th, 2016)	2450MHz	39.63	1.79
Target value	2600MHz	$39.0 \pm 5\%$	$1.96 \pm 5\%$
Validation value (Sep. 11th, 2016)	2600MHz	38.48	1.94

Table 4: Dielectric Performance of Body Tissue Simulating Liquid

Temperature: 23.2°C; Humidity: 64%;			
/	Frequency	Permittivity $\epsilon$	Conductivity $\sigma$ (S/m)
Target value	850MHz	$55.2 \pm 5\%$	$0.97 \pm 5\%$
Validation value (Sep. 5th, 2016)	850MHz	55.08	0.97
Target value	1800 MHz	$53.3 \pm 5\%$	$1.52 \pm 5\%$
Validation value (Sep. 6th, 2016)	1800 MHz	53.12	1.51
Target value	1900MHz	$53.3 \pm 5\%$	$1.52 \pm 5\%$
Validation value (Sep. 7th, 2016)	1900MHz	53.11	1.52
Target value	2450MHz	$52.7 \pm 5\%$	$1.95 \pm 5\%$
Validation value (Sep. 8th, 2016)	2450MHz	52.56	1.94
Target value	2600MHz	$52.5 \pm 5\%$	$2.16 \pm 5\%$
Validation value (Sep. 8th, 2016)	2600MHz	52.37	2.15

### 6.3 Results of validation testing

Prior to the assessment, the system validation kit was used to test whether the system was operating within its specifications of  $\pm 10\%$ . The validation results are tabulated below. And also the corresponding SAR plot is attached as well in the SAR plots files.

The following procedure, recommended for performing validation tests using box phantoms is based on the procedures described in the IEEE standard P1528. Setup according to the setup diagram below:

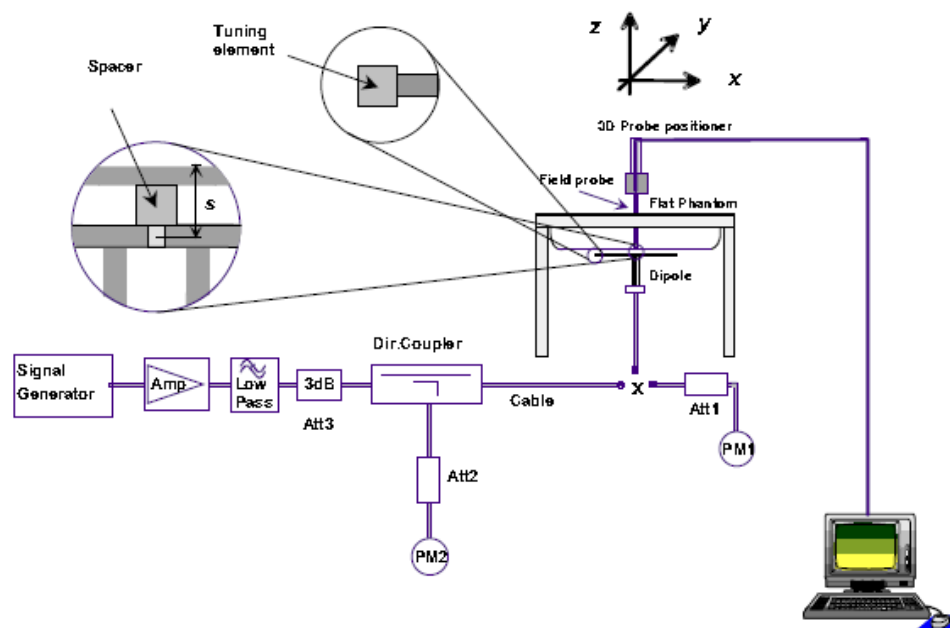

With the SG and Amp and with directional coupler in place, set up the source signal at the relevant frequency and use a power meter to measure the power at the end of the SMA cable that you intend to connect to the balanced dipole. Adjust the SG to make this, say, 0.25W (24 dBm). If this level is too high to read directly with the power meter sensor, insert a calibrated attenuator (e.g. 10 or 20 dB) and make a suitable correction to the power meter reading.

Note 1: In this method, the directional coupler is used for monitoring rather than setting the exact feed power level. If, however, the directional coupler is used for power measurement, you should check the frequency range and power rating of the coupler and measure the coupling factor (referred to output) at the test frequency using a VNA.

Note 2: Remember that the use of a 3dB attenuator (as shown in Figure 8.1 of P1528) means that you need an RF amplifier of 2 times greater power for the same feed power. The other issue is the cable length. You might get up to 1dB of loss per meter of cable, so the cable length after the coupler needs to be quite short.

Note 3: For the validation testing done using CW signals, most power meters are suitable. However, if you are measuring the output of a modulated signal from either a signal generator or a handset, you must ensure that the power meter correctly reads the modulated signals.

The measured 1-gram averaged SAR values of the device against the phantom are provided in Tables 5 and Table 6. The humidity and ambient temperature of test facility were 64% and 23.2°C respectively. The body phantom were full of the body tissue simulating liquid. The EUT was supplied with full-charged battery for each measurement.

The distance between the back of the EUT and the bottom of the flat phantom is 10 mm (taking into account of the IEEE 1528 and the place of the antenna).

Table 5: Head SAR system validation (1g)

Frequency	Duty cycle	Target value (W/kg)	Test value (W/kg)	
			250 mW	1W
835MHz(Sep. 9th, 2016)	1:1	9.77 ± 10%	2.38	9.52
1800MHz(Sep. 10th, 2016)	1:1	38.67 ± 10%	9.42	37.68
1900MHz(Sep. 10th, 2016)	1:1	40.37 ± 10%	9.94	39.76
2450MHz(Sep. 11th, 2016)	1:1	53.60 ± 10%	13.20	52.80
2600MHz(Sep. 11th, 2016)	1:1	56.19 ± 10%	14.00	56.00

Body SAR system validation (1g)

Frequency	Duty cycle	Target value (W/kg)	Test value (W/kg)	
			250 mW	1W
835MHz(Sep. 5th, 2016)	1:1	10.31 ± 10%	2.52	10.08
1800MHz(Sep. 6th, 2016)	1:1	40.07 ± 10%	9.87	39.48
1900MHz(Sep.7th, 2016)	1:1	40.81 ± 10%	10.15	40.60
2450MHz(Sep. 8th, 2016)	1:1	52.66 ± 10%	13.05	52.20
2600MHz(Sep. 8th, 2016)	1:1	57.55 ± 10%	14.06	56.24

\* Note: Target value was referring to the measured value in the calibration certificate of reference dipole.

Note: All SAR values are normalized to 1W forward power.

### 6.4 SAR measurement procedure

The SAR test against the head phantom was carried out as follow:

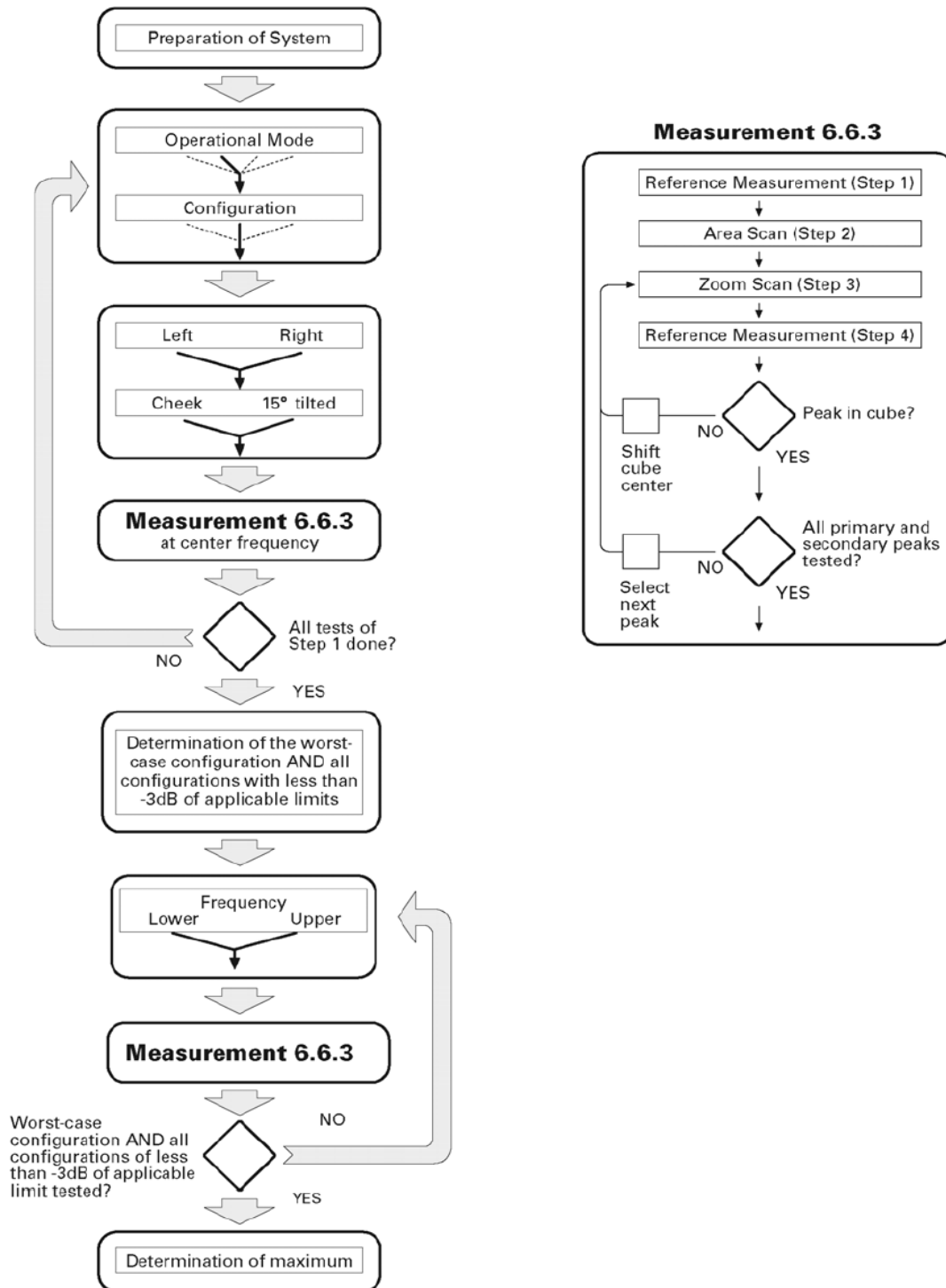

Establish a call with the maximum output power with a base station simulator, the connection between the EUT and the base station simulator is established via air interface.

After an area scan has been done at a fixed distance of 2mm from the surface of the phantom on the source side, a 3D scan is set up around the location of the maximum spot SAR. First, a point within the scan area is visited by the probe and a SAR reading taken at the start of testing. At the end of testing, the probe is returned to the same point and a



second reading is taken. Comparison between these start and end readings enables the power drift during measurement to be assessed.

Above is the scanning procedure flow chart and table from the IEEE p1528 standard. This is the procedure for which all compliant testing should be carried out to ensure that all variations of the device position and transmission behavior are tested.

For SAR measurement, the liquid deep max more than 15cm as below photo

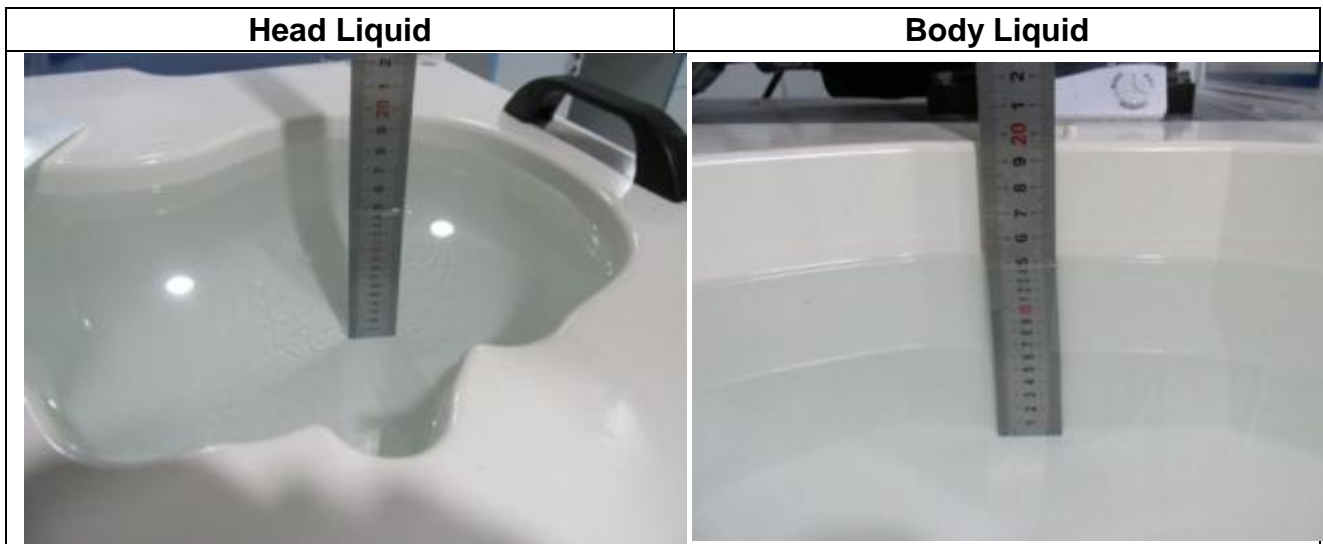

## 6.5 Transmitting antenna information

The GSM&WCDMA&LTE&WIFI&BT antennas inside the EUT.

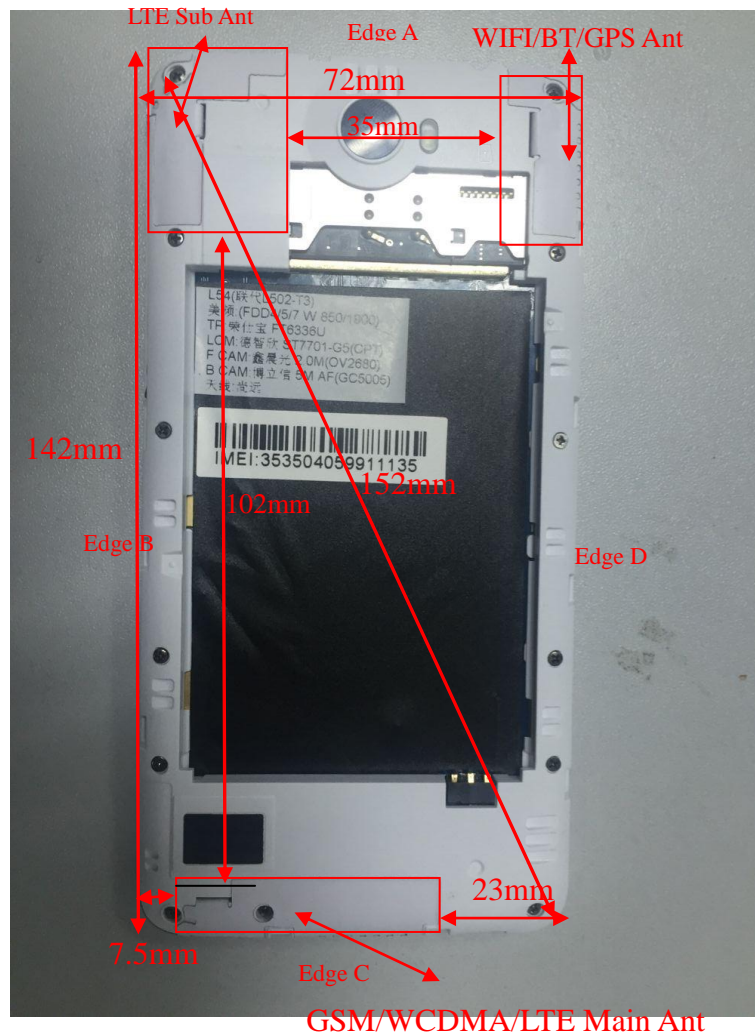

The Body SAR measurement positions of each band are as below:

Antenna	Front	Back	Edge A	Edge B	Edge C	Edge D
WWAN Antenna Body-worn	Yes	Yes	No	No	No	No
WWAN Antenna hotspot	Yes	Yes	No	Yes	Yes	Yes
WIFI Antenna Body-worn	Yes	Yes	No	No	No	No
WIFI Antenna hotspot	Yes	Yes	Yes	No	No	Yes

Note: According to KDB 941225 D06 v02r01, when antenna-to-edge > 2.5cm, SAR is not required.

## 7 CHARACTERISTICS OF THE TEST

### 7.1 Applicable Limit Regulations

**47CFR § 2.1093-** Radiofrequency Radiation Exposure Evaluation: Portable Devices;

**ANSI C95.1–1992:** Safety Levels with Respect to Human Exposure to Radio Frequency Electromagnetic Fields, 3 kHz – 300 GHz.( IEEE Std C95.1-1991)

**IEEE 1528–2013:** IEEE Recommended Practice for Determining the Peak Spatial-Average Specific Absorption Rate (SAR) in the Human Head from Wireless Communications Devices: Measurement Techniques

It specifies the maximum exposure limit of **1.6 W/kg** as averaged over any 1 gram of tissue for portable devices being used within 20 cm of the user in the uncontrolled environment.

### 7.2 Applicable Measurement Standards

The Specific Absorption Rate (SAR) testing specification, method, and procedure for this is in accordance with the following standards:

FCC 47 CFR Part2 (2.1093)

ANSI/IEEE C95.1-1992

IEEE 1528-2013

FCC KDB 248227 D01 802.11 Wi-Fi SAR v02r02

FCC KDB 447498 D01 v06 General RF Exposure Guidance

FCC KDB 648474 D04 v01r03 Handset SAR

FCC KDB 865664 D01 v01r04 SAR Measurement 100MHz to 6GHz

FCC KDB 865664 D02 v01r02 SAR Exposure Reporting

FCC KDB 941225 D01 v03r01 3G SAR Procedures

FCC KDB 941225 D05 v02r05 SAR for LTE Devices

FCC KDB 941225 D06 v02r01 Hotspot Mode

FCC KDB 941225 D04 v01 Evaluating SAR for GSM/(E)GPRS Dual Transfer Mode

## 8 LABORATORY ENVIRONMENTS

### The Ambient Conditions during SAR Test

Temperature	Min. = 22 °C, Max. = 25 °C
Atmospheric pressure	Min.=86 kPa, Max.=106 kPa
Relative humidity	Min. = 45%, Max. = 75%
Ground system resistance	< 0.5 Ω

Ambient noise is checked and found very low and in compliance with requirement of standards. Reflection of surrounding objects is minimized and in compliance with requirement of standards.

## 9. Conducted RF Output Power

### 9.1 GSM Conducted Power

Band		Burst Average Power (dBm)			Frame-Average Power (dBm)		
GSM850	TX Channel	128	190	251	128	190	251
	Frequency(MHz)	824.2	836.6	848.8	824.2	836.6	848.8
	GSM	32.72	32.78	32.82	23.53	23.59	23.63
	GPRS (Slot 1)	32.59	32.64	32.75	23.40	23.45	23.56
	GPRS (Slot 2)	29.23	29.12	29.33	23.10	22.99	23.20
	GPRS (Slot 3)	27.68	27.88	27.91	23.26	23.46	23.49
	GPRS (Slot 4)	26.83	26.95	26.76	23.65	23.77	23.58
	EDGE (Slot 1)	27.52	27.32	27.08	18.33	18.13	17.89
	EDGE (Slot 2)	25.02	25.13	25.05	18.89	19.00	18.92
	EDGE (Slot 3)	23.45	23.55	23.46	19.03	19.13	19.04
EDGE (Slot 4)	22.25	22.36	22.31	19.07	19.18	19.13	

Band		Burst Average Power (dBm)			Frame-Average Power (dBm)		
GSM1900	TX Channel	512	661	810	512	661	810
	Frequency(MHz)	1850.2	1880	1909.8	1850.2	1880	1909.8
	GSM	29.25	29.36	29.34	20.06	20.17	20.15
	GPRS (Slot 1)	29.15	29.29	29.21	19.96	20.10	20.02
	GPRS (Slot 2)	26.23	26.15	26.23	20.10	20.02	20.10
	GPRS (Slot 3)	24.88	24.84	24.76	20.46	20.42	20.34
	GPRS (Slot 4)	23.76	23.81	23.75	20.58	20.63	20.57
	EDGE (Slot 1)	26.04	26.13	26.32	16.85	16.94	17.13
	EDGE (Slot 2)	23.02	23.12	23.05	16.89	16.99	16.92
	EDGE (Slot 3)	21.55	21.36	21.42	17.13	16.94	17.00
EDGE (Slot 4)	20.36	20.42	20.38	17.18	17.24	17.20	

**Note:** Per KDB 447498 D01 v06, the maximum output power channel is used for SAR testing and for further SAR test reduction.

For hotspot SAR, EUT was performed at GPRS Class 12 multi-slots(4TX) mode

For Head and Body-worn SAR testing, EUT was set in GSM Voice mode for both GSM850 and GSM1900

#### Timeslot consignations

No. Of Slots	Slot 1	Slot 2	Slot 3	Slot 4
Slot Consignation	1Up4Down	2UpDown	3UpDown	4Up1Down
Duty Cycle	1:8	1:4	1:2.67	1:2
Crest Factor	-9.03dB	-6.02dB	-4.26dB	-3.01dB

## 9.2 WCDMA Conducted output Power

WCDMA conducted output power

Item	Band	WCDMA 850			WCDMA 1900		
	Frequency	4132	4183	4233	9262	9400	9538
	Subtest	dBm			dBm		
WCDMA	RMC 12.2Kbps	<b>22.68</b>	22.65	22.51	22.09	<b>22.24</b>	22.17
HSDPA	1	22.05	22.11	22.02	21.88	21.93	21.86
	2	21.95	21.90	21.91	21.75	21.70	21.67
	3	21.52	21.47	21.41	21.28	21.31	21.35
	4	21.61	21.52	21.55	21.37	21.31	21.38
HSUPA	1	21.82	21.88	21.90	21.75	21.69	21.71
	2	21.71	21.77	21.84	21.58	21.61	21.54
	3	21.51	21.45	21.53	21.35	21.37	21.41
	4	21.86	21.81	21.70	21.62	21.65	21.61
	5	21.47	21.58	21.52	21.41	21.37	21.43

### Note:

- WCDMA SAR was tested under PMC 12.2kbps with HSPA Inactive per KDB Publication 941225 D01v03r01. HSPA SAR was not required since the average output power of the HSPA subtests was not more than 0.25dB higher than the RMC level and SAR was less than 1.2W/kg.
- It is expected by the manufacturer that MPR for some HSPA subtests may be up to 2dB more than specified by 3GPP, but also as low as 0dB according to the chipset implementation in this model.

## 9.3 LTE Conducted peak output Power

### LTE Test Configurations

The CMW500 Wide Band Radio Communication Tester was used for LTE output power measurements and SAR testing. Closed loop power control was used so the UE transmits with maximum output power during SAR testing. SAR test were performed with the same number of RB and RB offsets transmitting on all frames.

#### 1) Spectrum Plots for RB configurations

A properly configured base station simulator was used for LTE output power measurements and SAR testing. Therefore, spectrum plots for RB configurations were not required to be included in this report.

#### 2) MPR

When MPR is implemented permanently within the UE, regardless of network requirements, only those RB configurations allowed by 3GPP for the channel bandwidth and modulation combinations may be tested with MPR active. Configurations with RB allocations less than the RB thresholds required by 3GPP must be tested without MPR.

The allowed Maximum Power Reduction(MPR) for the maximum output power due to higher order modulation and transmit bandwidth configuration (resource blocks) is specified in Table 6.2.3-1 of the 3GPP TS36.101:

**Table 6.2.3-1: Maximum Power Reduction (MPR) for Power Class 3**

Modulation	Channel bandwidth / Transmission bandwidth configuration [RB]						MPR (dB)
	1.4 MHz	3.0 MHz	5 MHz	10 MHz	15 MHz	20 MHz	
QPSK	> 5	> 4	> 8	> 12	> 16	> 18	≤ 1
16 QAM	≤ 5	≤ 4	≤ 8	≤ 12	≤ 16	≤ 18	≤ 1
16 QAM	> 5	> 4	> 8	> 12	> 16	> 18	≤ 2

#### 3)A-MPR LTE procedures for SAR testing

A-MPR(Additional MPR) has been disabled for all SAR tests by using Network Signaling Value of "NS\_01" on the base station simulator.

#### 4)LTE procedures for SAR testing

A) Largest channel bandwidth standalone SAR test requirements i) QPSK with 1 RB allocation

Start with the largest channel bandwidth and measure SAR for QPSK with 1 RB allocation, using the RB offset and required test channel combination with the highest maximum output power for RB offsets at the upper edge, middle and lower edge of each required test channel. When the reported SAR is  $\leq 0.8\text{W/kg}$ , testing of the remaining RB offset configurations and required test channels is not required for 1RB allocation; otherwise, SAR is required for the remaining required test channels and only for the RB offset configuration with the highest output power for that channel. When the reported SAR of a required test channel is  $> 1.45\text{ W/kg}$ , SAR is required for all three RB offset configurations for that required test channel.



1. LTE Band 4 Conducted Power Test Verdict:

BW(MHz)	Modulation	RB Size	RB Offset	Power(dBm) Low Ch./Freq.	Power(dBm) Middle Ch./Freq.	Power(dBm) High Ch./Freq.
Channel				20050	20175	20300
Frequency(MHz)				1720	1732.5	1745
20	QPSK	1	0	22.81	<b>22.86</b>	22.85
20		1	49	22.84	22.82	22.79
20		1	99	22.78	22.80	22.74
20		50	0	22.42	22.44	22.47
20		50	24	22.41	22.45	22.41
20		50	49	22.38	22.42	22.35
20		100	0	22.35	22.36	22.37
20	16QAM	1	0	21.82	21.91	21.84
20		1	49	21.80	21.85	21.83
20		1	99	21.84	21.80	21.77
20		50	0	21.37	21.29	21.32
20		50	24	21.29	21.27	21.30
20		50	49	21.31	21.25	21.26
20		100	0	21.34	21.25	21.21
Channel				20025	20175	20325
Frequency(MHz)				1717.5	1732.5	1747.5
15	QPSK	1	0	22.78	<b>22.82</b>	22.77
15		1	37	22.76	22.80	22.75
15		1	74	22.75	22.79	22.73
15		36	0	22.38	22.41	22.43
15		36	18	22.36	22.40	22.38
15		36	37	22.35	22.38	22.34
15		75	0	22.32	22.34	22.36
15	16QAM	1	0	21.81	21.87	21.82
15		1	37	21.78	21.82	21.79
15		1	74	21.82	21.77	21.75
15		36	0	21.35	21.27	21.30
15		36	18	21.26	21.28	21.27
15		36	37	21.26	21.25	21.26
15		75	0	21.30	21.21	21.24



BW(MHz)	Modulation	RB Size	RB Offset	Power(dBm) Low Ch./Freq.	Power(dBm) Middle Ch./Freq.	Power(dBm) High Ch./Freq.
Channel				20000	20175	20350
Frequency(MHz)				1715	1732.5	1750
10	QPSK	1	0	22.72	22.75	22.75
10		1	24	22.76	<b>22.79</b>	22.74
10		1	49	22.74	22.77	22.72
10		25	0	22.36	22.39	22.40
10		25	12	22.36	22.37	22.36
10		25	24	22.34	22.38	22.31
10		50	0	22.32	22.35	22.34
10		16QAM	1	0	21.78	21.83
10	1		24	21.77	21.76	21.79
10	1		49	21.75	21.74	21.75
10	25		0	21.32	21.33	21.28
10	25		12	21.23	21.24	21.26
10	25		24	21.30	21.21	21.25
10	50		0	21.26	21.24	21.27
Channel				19975	20175	20375
Frequency(MHz)				1712.5	1732.5	1752.5
5	QPSK	1	0	22.72	22.76	22.75
5		1	12	22.74	22.72	<b>22.77</b>
5		1	24	22.75	22.70	22.74
5		12	0	22.34	22.32	22.37
5		12	6	22.33	22.35	22.34
5		12	11	22.30	22.32	22.32
5		25	0	22.32	22.30	22.31
5		16QAM	1	0	21.75	21.82
5	1		12	21.74	21.76	21.78
5	1		24	21.73	21.72	21.75
5	12		0	21.32	21.24	21.34
5	12		6	21.29	21.23	21.25
5	12		11	21.26	21.24	21.22
5	25		0	21.22	21.23	21.25





BW(MHz)	Modulation	RB Size	RB Offset	Power(dBm) Low Ch./Freq.	Power(dBm) Middle Ch./Freq.	Power(dBm) High Ch./Freq.
Channel				19965	20175	20385
Frequency(MHz)				1711.5	1732.5	1753.5
3	QPSK	1	0	22.75	22.72	22.76
3		1	7	22.73	22.74	<b>22.78</b>
3		1	14	22.70	22.71	22.73
3		8	0	22.35	22.34	22.32
3		8	4	22.30	22.34	22.33
3		8	7	22.32	22.33	22.34
3		15	0	22.32	22.32	22.31
3	16QAM	1	0	21.74	21.84	21.81
3		1	7	21.75	21.78	21.73
3		1	14	21.76	21.72	21.75
3		8	0	21.29	21.22	21.26
3		8	4	21.24	21.23	21.25
3		8	7	21.25	21.21	21.23
3		15	0	21.24	21.25	21.20
Channel				19957	20175	20393
Frequency(MHz)				1710.7	1732.5	1754.3
1.4	QPSK	1	0	22.78	22.75	22.79
1.4		1	2	22.76	22.77	<b>22.80</b>
1.4		1	5	22.72	22.73	22.75
1.4		3	0	22.30	22.32	22.34
1.4		3	1	22.28	22.25	22.31
1.4		3	2	22.31	22.30	22.28
1.4		6	0	22.27	22.26	22.29
1.4	16QAM	1	0	21.74	21.79	21.77
1.4		1	2	21.73	21.74	21.72
1.4		1	5	21.70	21.75	21.71
1.4		3	0	21.30	21.29	21.32
1.4		3	1	21.25	21.26	21.24
1.4		3	2	21.27	21.25	21.24
1.4		6	0	21.23	21.20	21.22



2. LTE Band 5 Conducted Power Test Verdict:

BW(MHz)	Modulation	RB Size	RB Offset	Power(dBm) Low Ch./Freq.	Power(dBm) Middle Ch./Freq.	Power(dBm) High Ch./Freq.
Channel				20450	20525	20600
Frequency(MHz)				829	836.5	844
10	QPSK	1	0	23.27	<b>23.29</b>	23.25
10		1	24	23.25	23.22	23.23
10		1	49	23.22	23.24	23.20
10		25	0	22.81	22.89	22.84
10		25	12	22.78	22.76	22.80
10		25	24	22.77	22.74	22.75
10		50	0	22.75	22.72	22.78
10	16QAM	1	0	22.23	22.25	22.24
10		1	24	22.21	22.22	22.25
10		1	49	22.18	22.19	22.20
10		25	0	21.55	21.53	21.50
10		25	12	21.58	21.50	21.52
10		25	24	21.52	21.48	21.44
10		50	0	21.50	21.44	21.50
Channel				20425	20525	20625
Frequency(MHz)				826.5	836.5	846.5
5	QPSK	1	0	23.24	<b>23.25</b>	23.21
5		1	12	23.23	23.22	23.22
5		1	24	23.18	23.19	23.20
5		12	0	22.84	22.86	22.82
5		12	6	22.75	22.83	22.81
5		12	11	22.74	22.78	22.75
5		25	0	22.71	22.74	22.72
5	16QAM	1	0	22.29	22.21	22.22
5		1	12	22.22	22.19	22.20
5		1	24	22.20	22.17	22.18
5		12	0	21.57	21.53	21.54
5		12	6	21.48	21.50	21.52
5		12	11	21.45	21.48	21.51
5		25	0	21.47	21.44	21.43



BW(MHz)	Modulation	RB Size	RB Offset	Power(dBm) Low Ch./Freq.	Power(dBm) Middle Ch./Freq.	Power(dBm) High Ch./Freq.
Channel				20415	20525	20635
Frequency(MHz)				825.5	836.5	847.5
3	QPSK	1	0	23.25	<b>23.26</b>	23.24
3		1	7	23.24	23.22	23.21
3		1	14	23.23	23.20	23.17
3		8	0	22.77	22.81	22.76
3		8	4	22.80	22.75	22.78
3		8	7	22.78	22.72	22.75
3		15	0	22.70	22.74	22.71
3	16QAM	1	0	22.28	22.22	22.25
3		1	7	22.25	22.18	22.23
3		1	14	22.22	22.20	22.16
3		8	0	21.53	21.55	21.50
3		8	4	21.44	21.48	21.45
3		8	7	21.43	21.49	21.47
3		15	0	21.42	21.46	21.48
Channel				20407	20525	20643
Frequency(MHz)				824.7	836.5	848.3
1.4	QPSK	1	0	23.18	<b>23.22</b>	23.20
1.4		1	2	23.16	23.18	23.21
1.4		1	5	23.19	23.20	23.17
1.4		3	0	22.81	22.78	22.72
1.4		3	1	22.77	22.73	22.78
1.4		3	2	22.76	22.77	22.71
1.4		6	0	22.75	22.74	22.73
1.4	16QAM	1	0	22.22	22.27	22.29
1.4		1	2	22.23	22.24	22.21
1.4		1	5	22.24	22.22	22.26
1.4		3	0	21.55	21.54	21.55
1.4		3	1	21.59	21.53	21.45
1.4		3	2	21.50	21.48	21.47
1.4		6	0	21.48	21.42	21.45



3. LTE Band 7 Conducted Power Test Verdict:

BW(MHz)	Modulation	RB Size	RB Offset	Power(dBm) Low Ch./Freq.	Power(dBm) Middle Ch./Freq.	Power(dBm) High Ch./Freq.
Channel				20850	21100	21350
Frequency(MHz)				2510	2535	2560
20	QPSK	1	0	21.42	<b>21.46</b>	21.44
20		1	49	21.38	21.37	21.33
20		1	99	21.41	21.42	21.35
20		50	0	20.72	20.74	20.77
20		50	24	20.77	20.75	20.71
20		50	49	20.68	20.69	20.65
20		100	0	20.65	20.60	20.63
20	16QAM	1	0	20.20	20.21	20.15
20		1	49	20.24	20.22	20.23
20		1	99	20.18	20.17	20.18
20		50	0	19.77	19.75	19.72
20		50	24	19.69	19.67	19.70
20		50	49	19.64	19.61	19.66
20		100	0	19.70	19.65	19.71
Channel				20825	21100	21375
Frequency(MHz)				2507.5	2535	2562.5
15	QPSK	1	0	21.40	<b>21.42</b>	21.41
15		1	37	21.37	21.35	21.38
15		1	74	21.36	21.38	21.37
15		36	0	20.75	20.73	20.76
15		36	18	20.72	20.71	20.72
15		36	37	20.65	20.67	20.66
15		75	0	20.64	20.63	20.65
15	16QAM	1	0	20.22	20.25	20.19
15		1	37	20.24	20.22	20.15
15		1	74	20.17	20.15	20.14
15		36	0	19.75	19.74	19.79
15		36	18	19.69	19.68	19.72
15		36	37	19.65	19.66	19.64
15		75	0	19.71	19.65	19.67



BW(MHz)	Modulation	RB Size	RB Offset	Power(dBm) Low Ch./Freq.	Power(dBm) Middle Ch./Freq.	Power(dBm) High Ch./Freq.
Channel				20800	21100	21400
Frequency(MHz)				2505	2535	2565
10	QPSK	1	0	21.37	<b>21.40</b>	21.38
10		1	24	21.31	21.30	21.33
10		1	49	21.30	21.33	21.31
10		25	0	20.74	20.70	20.75
10		25	12	20.72	20.74	20.72
10		25	24	20.65	20.67	20.68
10		50	0	20.63	20.62	20.65
10	16QAM	1	0	20.13	20.20	20.15
10		1	24	20.20	20.12	20.21
10		1	49	20.15	20.10	20.15
10		25	0	19.70	19.64	19.63
10		25	12	19.61	19.65	19.64
10		25	24	19.55	19.50	19.55
10		50	0	19.50	19.55	19.53
Channel				20775	21100	21425
Frequency(MHz)				2502.5	2535	2567.5
5	QPSK	1	0	21.38	<b>21.39</b>	21.35
5		1	12	21.36	21.38	21.36
5		1	24	21.34	21.36	21.35
5		12	0	20.75	20.75	20.72
5		12	6	20.74	20.75	20.70
5		12	11	20.63	20.65	20.60
5		25	0	20.62	20.60	20.62
5	16QAM	1	0	20.20	20.24	20.23
5		1	12	20.25	20.22	20.20
5		1	24	20.19	20.14	20.18
5		12	0	19.74	19.70	19.72
5		12	6	19.65	19.61	19.70
5		12	11	19.65	19.66	19.60
5		25	0	19.59	19.60	19.67

## WLAN 2.4GHz Band Conducted Power

Channel/Freq.(MHz)	Maximum Conducted Out Power (dBm)		
	802.11b	802.11g	802.11n(HT20)
1(2412)	13.72	11.62	11.95
6(2437)	14.14	12.55	12.56
11(2462)	13.94	12.02	12.15
Channel/Freq.(MHz)	Maximum Conducted Out Power (dBm)		
	802.11n40		
3(2422)	11.88		
6(2437)	11.73		
9(2452)	11.94		

### Note:

1. Per KDB248227 D01 v02r02, choose the highest output power channel to test SAR and determine further SAR exclusion
2. For each frequency band, testing at higher data rates and higher order modulations is not required when the maximum average output power for each of these configurations is less than 1/4dB higher than those measured at lowest data rate
3. Per KDB248227 D01 v02r02, 802.11g /11n-HT20/11n-HT40 is not required. . When the highest reported SAR for DSSS is adjusted by the ratio of OFDM to DSSS specified maximum output power and the adjusted SAR is  $\leq 1.2W/Kg$ . Thus the SAR can be excluded.

## Bluetooth Output Power

Channel	Frequency (MHz)	BT3.0 Output Power(dBm)		
		GFSK	$\pi$ /4-DQPSK	8-DPSK
CH 0	2402	1.17	0.59	0.80
CH 39	2441	0.71	0.56	0.79
CH 78	2480	1.10	0.96	1.05
Channel	Frequency (MHz)	BT4.0 Output Power(dBm)		
		GFSK		
CH 0	2402	-5.25		
CH 20	2442	-5.03		
CH 39	2480	-5.92		

**SAR test Exclusion and estimate SAR calculation:****Note:**

1. Per KDB 447498 D01v06, the 1-g and 10-g SAR test exclusion thresholds for 100MHz to 6GHz at test separation distances  $\leq 50\text{mm}$  are determined by:  $[(\text{max. power of channel, including tune-up tolerance, mW})/(\text{min. test separation distance, mm})] \cdot [\sqrt{f} \text{ (GHz)}] \leq 3.0$  for 1-g SAR and  $\leq 7.5$  for 10-g extremity SAR
- (1) f(GHz) is the RF channel transmit frequency in GHz
  - (2) Power and distance are round to the nearest mW and mm before calculation
  - (3) The result is rounded to one decimal place for comparison
  - (4) If the test separation distance(antenna-user) is  $< 5\text{mm}$ , 5mm is used for excluded SAR calculation
  - (5)

BT3.0 Max Power (dBm)	mW	Test Distance (mm)	Frequency(GHz)	Exclusion Thresholds
1.5	1.413	5	2.45	0.442

Per KDB 447498 D01v06 exclusion thresholds is  $0.442 < 3$ , RF exposure evaluation is not required.

BT estimated SAR value=Exclusion Thresholds/7.5= $0.442/7.5=0.059\text{W/Kg}$

BT3.0 Max Power (dBm)	mW	Test Distance (mm)	Frequency(GHz)	Exclusion Thresholds
1.5	1.413	10	2.45	0.221

Per KDB 447498 D01v06 exclusion thresholds is  $0.221 < 3$ , RF exposure evaluation is not required.

BT estimated SAR value=Exclusion Thresholds/7.5= $0.221/7.5=0.029\text{W/Kg}$

BT4.0 Max Power (dBm)	mW	Test Distance (mm)	Frequency(GHz)	Exclusion Thresholds
-4.5	0.355	5	2.45	0.111

Per KDB 447498 D01v06 exclusion thresholds is  $0.198 < 3$ , RF exposure evaluation is not required.

BT estimated SAR value=Exclusion Thresholds/7.5= $0.111/7.5=0.015\text{W/Kg}$

BT4.0 Max Power (dBm)	mW	Test Distance (mm)	Frequency(GHz)	Exclusion Thresholds
-4.5	0.355	10	2.45	0.056

Per KDB 447498 D01v06 exclusion thresholds is  $0.099 < 3$ , RF exposure evaluation is not required.

BT estimated SAR value=Exclusion Thresholds/7.5= $0.056/7.5=0.007\text{W/Kg}$

The estimated SAR value is used for simultaneous transmission analysis.

## General Note:

1. Per KDB 447498 D01v06, the reported SAR is the measured SAR value adjusted for maximum tune-up tolerance.
2. Per KDB447498 D01v06, testing of other required channels within the operating mode of a frequency band is not required when the reported 1-g or 10-g SAR for the mid-band or highest output power channel is:  $\leq 0.8$  W/kg or 2.0 W/kg, for 1-g or 10-g respectively, when the transmission band is  $\leq 100$  MHz. When the maximum output power variation across the required test channels is  $> \frac{1}{2}$  dB, instead of the middle channel, the highest output power channel must be used.
3. Per KDB941225 D06 v02r01, the DUT Dimension is bigger than 9 cm x 5 cm, so 10mm is chosen as the test separation distance for Hotspot mode. When the antenna-to-edge distance is greater than 2.5cm, such position does not need to be tested. As the manufacture required, the separation distance use 5mm for Hotspot mode.
4. Per KDB 865664 D01v01r04, for each frequency band, repeated SAR measurement is required only when the measured SAR is  $\geq 0.8$ W/Kg; if the deviation among the repeated measurement is  $\leq 20\%$ , and the measured SAR  $< 1.45$ W/Kg, only one repeated measurement is required.
5. Per KDB865664 D02 v01r02, SAR plot is only required for the highest measured SAR in each exposure configuration, wireless mode and frequency band combination; Plots are also required when the measured SAR is  $> 1.5$  W/kg, or  $> 7.0$  W/kg for occupational exposure. The published RF exposure KDB procedures may require additional plots; for example, to support SAR to peak location separation ratio test exclusion and/or volume scan post-processing(Refer to appendix D for details).
6. Per KDB941225 D04 v01, when multiple slots can be used, the GPRS/EDGE slot configuration with the highest frame-averaged output power was selected for SAR testing.
7. Per KDB941225 D01 v03r01, when the maximum output power and tune-up tolerance specified for production units in a secondary mode is  $\leq \frac{1}{4}$  dB higher than the primary mode or when the highest reported SAR of the primary mode is scaled by the ratio of specified maximum output power and tune-up tolerance of secondary to primary mode and the adjusted SAR is  $\leq 1.2$  W/kg, SAR measurement is not required for the secondary mode.
8. Per KDB248227 D01 v02r02, 802.11g /11n-HT20/11n-HT40 is not required. When the highest reported SAR for DSSS is adjusted by the ratio of OFDM to DSSS specified maximum output power and the adjusted SAR is  $\leq 1.2$ W/Kg. Thus the SAR can be excluded.



### 9.3. Scaling Factor calculation

Operation Mode	Channel	Output Power(dBm)	Tune up Power in tolerance(dBm)	Scaling Factor
GSM 850	128	32.72	32.0 ± 1.0	1.067
	190	32.78	32.0 ± 1.0	1.052
	251	32.82	32.0 ± 1.0	1.042
GPRS 850(4Tx)	128	26.83	26.0 ± 1.0	1.040
	190	26.95	26.0 ± 1.0	1.012
	251	26.76	26.0 ± 1.0	1.057
GSM1900	512	29.25	28.5 ± 1.0	1.059
	661	29.36	28.5 ± 1.0	1.033
	810	29.34	28.5 ± 1.0	1.038
GPRS1900(4Tx)	512	23.76	23.0 ± 1.0	1.057
	661	23.81	23.0 ± 1.0	1.045
	810	23.75	23.0 ± 1.0	1.059
WCDMA850	4132	22.68	22.0 ± 1.0	1.076
	4183	22.65	22.0 ± 1.0	1.084
	4233	22.51	22.0 ± 1.0	1.119
WCDMA1900	9262	22.09	21.5 ± 1.0	1.099
	9400	22.24	21.5 ± 1.0	1.062
	9538	22.17	21.5 ± 1.0	1.079
LTE B4 20MHz 1RB#0	20050	22.81	22.0 ± 1.0	1.045
	20175	22.86	22.0 ± 1.0	1.033
	20300	22.85	22.0 ± 1.0	1.035
LTE B4 20MHz 50RB#0	20050	22.42	21.5 ± 1.0	1.019
	20175	22.44	21.5 ± 1.0	1.014
	20300	22.47	21.5 ± 1.0	1.007
LTE B5 10MHz 1RB#0	20450	23.27	22.5 ± 1.0	1.054
	20525	23.29	22.5 ± 1.0	1.050
	20600	23.25	22.5 ± 1.0	1.059
LTE B5 10MHz 25RB#0	20450	22.81	22.0 ± 1.0	1.045
	20525	22.89	22.0 ± 1.0	1.026
	20600	22.84	22.0 ± 1.0	1.038
LTE B7 20MHz 1RB#0	20850	21.42	20.5 ± 1.0	1.019
	21100	21.46	20.5 ± 1.0	1.009
	21350	21.44	20.5 ± 1.0	1.014
LTE B7 20MHz 50RB#0	20850	20.72	20.0 ± 1.0	1.067
	21100	20.74	20.0 ± 1.0	1.062
	21350	20.77	20.0 ± 1.0	1.054
WIFI 802.11b	1	13.72	13.5 ± 1.0	1.191
	6	14.14	13.5 ± 1.0	1.086
	11	13.94	13.5 ± 1.0	1.138
BT	0	1.17	0.5 ± 1.0	1.079

Note: for LTE power tolerance, only QPSK modulation mode was provide here.

## 10 TEST RESULTS

### 10.1 Summary of SAR Measurement Results

Table 7: SAR Values of GSM 850MHz Band

Temperature: 23.0~23.5°C, humidity: 62~64%.							
Test Positions		Channel /Frequency (MHz)	SAR(W/Kg), 1.6 (1g average)			Plot No.	
			SAR (W/Kg),1g	Scaled Factor	Scaled SAR(W/Kg) ,1g		
Right Side of Head	Cheek	190/836.6	<b>0.298</b>	1.052	<b>0.313</b>	<b>1</b>	
	Tilt 15 degrees	190/836.6	0.240	1.052	0.252	--	
Left Side of Head	Cheek	190/836.6	0.225	1.052	0.237	--	
	Tilt 15 degrees	190/836.6	0.196	1.052	0.206	--	
Body-worn (10mm Separation)	GSM	Face Upward	190/836.6	0.334	1.052	0.351	--
		Back Upward	190/836.6	<b>0.393</b>	1.052	<b>0.413</b>	<b>2</b>
Hotspot (10mm Separation)	GPRS (4Tx)	Face Upward	190/836.6	0.449	1.012	0.454	--
		Back Upward	190/836.6	<b>0.545</b>	1.012	<b>0.552</b>	<b>3</b>
		Edge B	190/836.6	0.138	1.012	0.140	--
		Edge C	190/836.6	0.152	1.012	0.154	--
		Edge D	190/836.6	0.193	1.012	0.195	--

Table 8: SAR Values of GSM1900 MHz Band

Temperature: 23.0~23.5°C, humidity: 62~64%.							
Test Positions		Channel /Frequency (MHz)	SAR(W/Kg), 1.6 (1g average)			Plot No.	
			SAR (W/Kg),1g	Scaled Factor	Scaled SAR(W/Kg) ,1g		
Right Side of Head	Cheek	661/1880.0	<b>0.237</b>	1.033	<b>0.245</b>	<b>4</b>	
	Tilt 15 degrees	661/1880.0	0.122	1.033	0.126	--	
Left Side of Head	Cheek	661/1880.0	0.099	1.033	0.102	--	
	Tilt 15 degrees	661/1880.0	0.071	1.033	0.073	--	
Body-worn (10mm Separation)	GSM	Face Upward	661/1880.0	0.430	1.033	0.444	--
		Back Upward	661/1880.0	<b>0.520</b>	1.033	<b>0.537</b>	<b>5</b>
Hotspot (10mm Separation)	GPRS (4Tx)	Face Upward	661/1880.0	0.458	1.045	0.479	--
		Back Upward	661/1880.0	<b>0.646</b>	1.045	<b>0.675</b>	<b>6</b>
		Edge B	661/1880.0	0.200	1.045	0.209	--
		Edge C	661/1880.0	0.441	1.045	0.461	--
		Edge D	661/1880.0	0.075	1.045	0.078	--

Table 9: SAR Values of WCDMA850

Temperature: 23.0~23.5°C, humidity: 62~64%.						
Test Positions		Channel /Frequency (MHz)	SAR(W/Kg), 1.6 (1g average)			Plot No.
			SAR (W/Kg), 1g	Scaled Factor	Scaled SAR(W/Kg),1g	
Right Side of Head	Cheek	4183/836.6	<b>0.217</b>	1.084	<b>0.235</b>	<b>7</b>
	Tilt 15 degrees	4183/836.6	0.183	1.084	0.198	--
Left Side of Head	Cheek	4183/836.6	0.210	1.084	0.228	--
	Tilt 15 degrees	4183/836.6	0.165	1.084	0.179	--
Body-worn (10mm Separation)	Face Upward	4183/836.6	0.245	1.084	0.266	--
	Back Upward	4183/836.6	<b>0.329</b>	1.084	<b>0.357</b>	<b>8</b>
Hotspot (10mm Separation)	Face Upward	4183/836.6	0.245	1.084	0.266	--
	Back Upward	4183/836.6	<b>0.329</b>	1.084	<b>0.357</b>	<b>8</b>
	Edge B	4183/836.6	0.126	1.084	0.137	--
	Edge C	4183/836.6	0.114	1.084	0.124	--
	Edge D	4183/836.6	0.066	1.084	0.072	--

Table 11: SAR Values of WCDMA1900

Temperature: 23.0~23.5°C, humidity: 62~64%.						
Test Positions		Channel /Frequency (MHz)	SAR(W/Kg), 1.6 (1g average)			Plot No.
			SAR (W/Kg),1g	Scaled Factor	Scaled SAR(W/Kg),1g	
Right Side of Head	Cheek	9400/1880	<b>0.440</b>	1.062	<b>0.467</b>	<b>9</b>
	Tilt 15 degrees	9400/1880	0.174	1.062	0.185	--
Left Side of Head	Cheek	9400/1880	0.304	1.062	0.323	--
	Tilt 15 degrees	9400/1880	0.206	1.062	0.219	--
Body-worn (10mm Separation)	Face Upward	9400/1880	0.735	1.062	0.781	--
	Back Upward	9262/1852.4	0.931	1.099	1.023	--
	Back Upward	9400/1880	<b>0.964</b>	1.062	<b>1.024</b>	<b>10</b>
	Back Upward	9538/1907.6	0.923	1.079	0.996	--
	Back Upward, repeated	9262/1852.4	0.915	1.099	1.006	--
	Back Upward, repeated	9400/1880	0.922	1.062	0.979	--
	Back Upward, repeated	9538/1907.6	0.906	1.079	0.978	--
Hotspot (10mm Separation)	Face Upward	9400/1880	0.735	1.062	0.781	--
	Back Upward	9262/1852.4	0.931	1.099	1.023	--
	Back Upward	9400/1880	<b>0.964</b>	1.062	<b>1.024</b>	<b>10</b>
	Back Upward	9538/1907.6	0.923	1.079	0.996	--
	Back Upward, repeated	9262/1852.4	0.915	1.099	1.006	--
	Back Upward, repeated	9400/1880	0.922	1.062	0.979	--
	Back Upward, repeated	9538/1907.6	0.906	1.079	0.978	--
	Edge B	9400/1880	0.311	1.062	0.330	--
	Edge C	9400/1880	0.523	1.062	0.555	--
	Edge D	9400/1880	0.343	1.062	0.364	--



Table 13: SAR Values of LTE Band 4, 20MHz, QPSK

Temperature: 23.0~23.5°C, humidity: 62~64%.						
Test Positions	Channel /Frequency (MHz)	SAR(W/Kg), 1.6 (1g average)			Plot No.	
		SAR (W/Kg),1g	Scaled Factor	Scaled SAR(W/Kg), 1g		
1RB #0						
Right Side of Head	Cheek	20175/1732.5	<b>0.222</b>	1.033	<b>0.229</b>	<b>11</b>
	Tilt 15 degrees	20175/1732.5	0.111	1.033	0.115	--
Left Side of Head	Cheek	20175/1732.5	0.215	1.033	0.222	--
	Tilt 15 degrees	20175/1732.5	0.093	1.033	0.096	--
Body (10mm Separation) Body-worn	Face Upward	20175/1732.5	0.304	1.033	0.314	--
	Back Upward	20175/1732.5	<b>0.346</b>	1.033	<b>0.357</b>	<b>12</b>
Body (10mm Separation) Hotspot	Face Upward	20175/1732.5	0.304	1.033	0.314	--
	Back Upward	20175/1732.5	<b>0.346</b>	1.033	<b>0.357</b>	<b>12</b>
	Edge B	20175/1732.5	0.082	1.033	0.085	--
	Edge C	20175/1732.5	0.320	1.033	0.331	--
	Edge D	20175/1732.5	0.173	1.033	0.179	--
50%RB #0						
Right Side of Head	Cheek	20175/1732.5	0.212	1.014	0.215	--
	Tilt 15 degrees	20175/1732.5	0.103	1.014	0.104	--
Left Side of Head	Cheek	20175/1732.5	0.208	1.014	0.211	--
	Tilt 15 degrees	20175/1732.5	0.064	1.014	0.065	--
Body (10mm Separation) Body-worn	Face Upward	20175/1732.5	0.267	1.014	0.271	--
	Back Upward	20175/1732.5	0.312	1.014	0.316	--
Body (10mm Separation) Hotspot	Face Upward	20175/1732.5	0.267	1.014	0.271	--
	Back Upward	20175/1732.5	0.312	1.014	0.316	--
	Edge B	20175/1732.5	0.056	1.014	0.057	--
	Edge C	20175/1732.5	0.302	1.014	0.306	--
	Edge D	20175/1732.5	0.143	1.014	0.145	--



Table 14: SAR Values of LTE Band 5 , 10MHz, QPSK

Temperature: 23.0~23.5°C, humidity: 62~64%.						
Test Positions	Channel /Frequency (MHz)	SAR(W/Kg), 1.6 (1g average)			Plot No.	
		SAR (W/Kg),1g	Scaled Factor	Scaled SAR(W/Kg), 1g		
1RB #0						
Right Side of Head	Cheek	20525/836.5	<b>0.178</b>	1.050	<b>0.187</b>	<b>13</b>
	Tilt 15 degrees	20525/836.5	0.102	1.050	0.107	--
Left Side of Head	Cheek	20525/836.5	0.171	1.050	0.180	--
	Tilt 15 degrees	20525/836.5	0.151	1.050	0.159	--
Body (10mm Separation) Body-worn	Face Upward	20525/836.5	0.211	1.050	0.222	--
	Back Upward	20525/836.5	<b>0.233</b>	1.050	<b>0.245</b>	<b>14</b>
Body (10mm Separation) Hotspot	Face Upward	20525/836.5	0.211	1.050	0.222	--
	Back Upward	20525/836.5	<b>0.233</b>	1.050	<b>0.245</b>	<b>14</b>
	Edge B	20525/836.5	0.136	1.050	0.143	--
	Edge C	20525/836.5	0.176	1.050	0.185	--
	Edge D	20525/836.5	0.155	1.050	0.163	--
50%RB #0						
Right Side of Head	Cheek	20525/836.5	0.153	1.026	0.157	--
	Tilt 15 degrees	20525/836.5	0.086	1.026	0.088	--
Left Side of Head	Cheek	20525/836.5	0.137	1.026	0.141	--
	Tilt 15 degrees	20525/836.5	0.111	1.026	0.114	--
Body (10mm Separation) Body-worn	Face Upward	20525/836.5	0.205	1.026	0.210	--
	Back Upward	20525/836.5	0.213	1.026	0.219	--
Body (10mm Separation) Hotspot	Face Upward	20525/836.5	0.205	1.026	0.210	--
	Back Upward	20525/836.5	0.213	1.026	0.219	--
	Edge B	20525/836.5	0.115	1.026	0.118	--
	Edge C	20525/836.5	0.153	1.026	0.157	--
	Edge D	20525/836.5	0.131	1.026	0.134	--



Table 15: SAR Values of LTE Band 7,20MHz, QPSK

Temperature: 23.0~23.5°C, humidity: 62~64%.						
Test Positions	Channel /Frequency (MHz)	SAR(W/Kg), 1.6 (1g average)			Plot No.	
		SAR (W/Kg),1g	Scaled Factor	Scaled SAR(W/Kg),1g		
1RB #0						
Right Side of Head	Cheek	21100/2535	<b>0.252</b>	1.009	<b>0.254</b>	<b>15</b>
	Tilt 15 degrees	21100/2535	0.136	1.009	0.137	--
Left Side of Head	Cheek	21100/2535	0.235	1.009	0.237	--
	Tilt 15 degrees	21100/2535	0.119	1.009	0.120	--
Body (10mm Separation) Body-worn	Face Upward	21100/2535	0.602	1.009	0.607	--
	Back Upward	21100/2535	<b>0.701</b>	1.009	<b>0.707</b>	<b>16</b>
Body (10mm Separation) Hotspot	Face Upward	21100/2535	0.602	1.009	0.607	--
	Back Upward	21100/2535	<b>0.701</b>	1.009	<b>0.707</b>	<b>16</b>
	Edge B	21100/2535	0.182	1.009	0.184	--
	Edge C	21100/2535	0.499	1.009	0.503	--
	Edge D	21100/2535	0.017	1.009	0.017	--
50%RB #0						
Right Side of Head	Cheek	21100/2535	0.235	1.062	0.250	--
	Tilt 15 degrees	21100/2535	0.111	1.062	0.118	--
Left Side of Head	Cheek	21100/2535	0.205	1.062	0.218	--
	Tilt 15 degrees	21100/2535	0.096	1.062	0.102	--
Body (10mm Separation) Body-worn	Face Upward	21100/2535	0.553	1.062	0.587	--
	Back Upward	21100/2535	0.638	1.062	0.678	--
Body (10mm Separation) Hotspot	Face Upward	21100/2535	0.553	1.062	0.587	--
	Back Upward	21100/2535	0.638	1.062	0.678	--
	Edge B	21100/2535	0.155	1.062	0.165	--
	Edge C	21100/2535	0.438	1.062	0.465	--
	Edge D	21100/2535	0.012	1.062	0.013	--

Table 16: SAR Values of Wi-Fi 802.11b

Test Positions		Channel /Frequency (MHz)	SAR(W/Kg), 1.6 (1g average)			Plot No.
			SAR(W/Kg) 1g	Scaled Factor	Scaled SAR(W/Kg) ,1g	
Right Side of Head	Cheek	6/2437	0.202	1.086	0.219	--
	Tilt 15 degrees	6/2437	0.125	1.086	0.136	--
Left Side of Head	Cheek	6/2437	<b>0.374</b>	1.086	<b>0.406</b>	<b>17</b>
	Tilt 15 degrees	6/2437	0.249	1.086	0.270	--
Body-worn (10mm Separation)	Face Upward	6/2437	0.080	1.086	0.087	--
	Back Upward	6/2437	<b>0.165</b>	1.086	<b>0.179</b>	<b>18</b>
Hotspot (10mm Separation)	Face Upward	6/2437	0.080	1.086	0.087	--
	Back Upward	6/2437	<b>0.165</b>	1.086	<b>0.179</b>	<b>18</b>
	Edge A	6/2437	0.055	1.086	0.060	--
	Edge D	6/2437	0.041	1.086	0.045	--

## Note:

Per KDB Publication 941225 D01v03r01. RMC 12.2kbps was as primary mode SAR, when the primary mode SAR less than 1.2W/kg, secondary SAR (HSPA) was not requires.

When the 1-g SAR for the mid-band channel or the channel with the highest output power satisfy the following conditions, testing of the other channels in the band is not required. (Per KDB 447498 D01 General RF Exposure Guidance v06)

- $\leq 0.8$  W/kg, when the transmission band is  $\leq 100$  MHz
- $\leq 0.6$  W/kg, when the transmission band is between 100 MHz and 200 MHz
- $\leq 0.4$  W/kg, when the transmission band is  $\geq 200$  MHz



## 10.2 Simultaneous Transmissions Analysis

Localized Specific Absorption Rate (SAR) of this portable wireless device has been measured in all cases requested by the relevant standards cited in Clause 6 of this report. Maximum localized SAR is **below** exposure limits specified in the relevant standards.

### Simultaneous SAR

No.	Transmitter Combinations	Scenario Supported or not	Supported for Mobile Hotspot or not
1	GSM+ BT	Yes	No
2	GSM + WIFI	Yes	Yes
3	WCDMA +BT	Yes	No
4	WCDMA +WIFI	Yes	Yes
5	LTE+BT	Yes	No
6	LTE+WIFI	Yes	Yes
7	WIFI+BT	No	No





Test Position		Right Cheek	Right Title	Left Cheek	Left Tilt
Head MAX 1-g SAR(W/Kg)	GSM850	0.313	0.252	0.237	0.206
	GSM1900	0.245	0.126	0.102	0.073
	WCDMA850	0.235	0.198	0.228	0.179
	WCDMA1900	0.467	0.185	0.323	0.219
	LTE Band4	0.229	0.115	0.222	0.096
	LTE Band5	0.187	0.107	0.180	0.159
	LTE Band7	0.254	0.137	0.237	0.120
	WIFI 802.11b	0.219	0.136	0.406	0.270
	BT	*0.059	*0.059	*0.059	*0.059
WIFI Simultaneous $\Sigma$ 1-g SAR(W/Kg)		0.686	0.388	0.729	0.489
BT Simultaneous $\Sigma$ 1-g SAR(W/Kg)		0.526	0.311	0.382	0.278

Simultaneous Tx Combination of GSM/WCDMA/LTE and BT/WIFI (Head).

Test Position		Face	Back	Edge A	Edge B	Edge C	Edge D
Body-worn 10mm separation MAX 1-g SAR(W/Kg)	GSM850	0.351	0.413	--	--	--	--
	GSM1900	0.444	0.537	--	--	--	--
	WCDMA850	0.266	0.357	--	--	--	--
	WCDMA1900	0.781	1.024	--	--	--	--
	LTE Band4	0.314	0.357	--	--	--	--
	LTE Band5	0.222	0.245	--	--	--	--
	LTE Band7	0.607	0.707	--	--	--	--
	WIFI 802.11b	0.087	0.179	--	--	--	--
	BT	*0.029	*0.029	--	--	--	--
WIFI Simultaneous $\Sigma$ 1-g SAR(W/Kg)		0.868	1.203	--	--	--	--
BT Simultaneous $\Sigma$ 1-g SAR(W/Kg)		0.810	1.053	--	--	--	--

Simultaneous Tx Combination of GSM/WCDMA/LTE and BT/WIFI (Body).



Test Position		Face	Back	Edge A	Edge B	Edge C	Edge D
Hotspot 10mm separation MAX 1-g SAR(W/Kg)	GPRS850	0.454	0.552	--	0.140	0.154	0.195
	GPRS1900	0.479	0.675	--	0.209	0.461	0.078
	WCDMA 850	0.266	0.357	--	0.137	0.124	0.072
	WCDMA 1900	0.781	1.024	--	0.330	0.555	0.364
	LTE Band4	0.314	0.357	--	0.085	0.331	0.179
	LTE Band5	0.222	0.245	--	0.143	0.185	0.163
	LTE Band7	0.607	0.707	--	0.184	0.503	0.017
	WIFI 802.11b	0.087	0.179	0.060	--	--	0.045
BT	*0.029	*0.029	*0.029	*0.029	*0.029	*0.029	
WIFI Simultaneous $\Sigma$ 1-g SAR(W/Kg)		0.868	1.203	--	--	--	0.409
BT Simultaneous $\Sigma$ 1-g SAR(W/Kg)		0.810	1.053	--	--	--	0.393

Simultaneous Tx Combination of GSM/WCDMA/LTE and WIFI (Body).

The estimated SAR value with \* Signal

**SAR to Peak Location Separation Ratio (SPLSR)**

As the Sum of the SAR is not greater than 1.6 W/kg SPLSR assessment is not required

## 11 Measurement Uncertainty

No.	Uncertainty Component	Type	Uncertainty Value (%)	Probability Distribution	k	ci	Standard Uncertainty (%) $u_i(\%)$	Degree of freedom $\nu_{eff}$ or $\nu_i$
<b>Measurement System</b>								
1	– Probe Calibration	B	5.8	N	1	1	5.8	$\infty$
2	– Axial isotropy	B	3.5	R	$\sqrt{3}$	0.5	1.43	$\infty$
3	– Hemispherical Isotropy	B	5.9	R	$\sqrt{3}$	0.5	2.41	$\infty$
4	– Boundary Effect	B	1	R	$\sqrt{3}$	1	0.58	$\infty$
5	– Linearity	B	4.7	R	$\sqrt{3}$	1	2.71	$\infty$
6	– System Detection Limits	B	1.0	R	$\sqrt{3}$	1	0.58	$\infty$
7	Modulation response	B	3	N	1	1	3.00	
8	– Readout Electronics	B	0.5	N	1	1	0.50	$\infty$
9	– Response Time	B	1.4	R	$\sqrt{3}$	1	0.81	$\infty$
10	– Integration Time	B	3.0	R	$\sqrt{3}$	1	1.73	$\infty$
11	– RF Ambient Conditions	B	3.0	R	$\sqrt{3}$	1	1.73	$\infty$
12	– Probe Position Mechanical tolerance	B	1.4	R	$\sqrt{3}$	1	0.81	$\infty$
13	– Probe Position with respect to Phantom Shell	B	1.4	R	$\sqrt{3}$	1	0.81	$\infty$
14	– Extrapolation, Interpolation and Integration Algorithms for Max. SAR evaluation	B	2.3	R	$\sqrt{3}$	1	1.33	$\infty$
<b>Uncertainties of the DUT</b>								
15	– Position of the DUT	A	2.6	N	$\sqrt{3}$	1	2.6	5
16	– Holder of the DUT	A	3	N	$\sqrt{3}$	1	3.0	5



17	- Output Power Variation -SAR drift measurement	B	5.0	R	$\sqrt{3}$	1	2.89	$\infty$
<b>Phantom and Tissue Parameters</b>								
18	- Phantom Uncertainty(shape and thickness tolerances)	B	4	R	$\sqrt{3}$	1	2.31	$\infty$
19	Uncertainty in SAR correction for deviation(in permittivity and conductivity)	B	2	N	1	1	2.00	
20	- Liquid Conductivity Target -tolerance	B	2.5	R	$\sqrt{3}$	0.6	1.95	$\infty$
21	- Liquid Conductivity -measurement Uncertainty)	B	4	N	$\sqrt{3}$	1	0.92	9
22	- Liquid Permittivity Target tolerance	B	2.5	R	$\sqrt{3}$	0.6	1.95	$\infty$
23	- Liquid Permittivity -measurement uncertainty	B	5	N	$\sqrt{3}$	1	1.15	$\infty$
<b>Combined Standard Uncertainty</b>				RSS			10.63	
<b>Expanded uncertainty</b> (Confidence interval of 95 %)				K=2			21.26	

### System Check Uncertainty

No.	Uncertainty Component	Type	Uncertainty Value (%)	Probability Distribution	k	ci	Standard Uncertainty (%) $u_i(\%)$	Degree of freedom $v_{eff}$ or $v_i$
<b>Measurement System</b>								
1	- Probe Calibration	B	5.8	N	1	1	5.8	$\infty$
2	- Axial isotropy	B	3.5	R	$\sqrt{3}$	0.5	1.43	$\infty$
3	- Hemispherical Isotropy	B	5.9	R	$\sqrt{3}$	0.5	2.41	$\infty$
4	- Boundary Effect	B	1	R	$\sqrt{3}$	1	0.58	$\infty$
5	- Linearity	B	4.7	R	$\sqrt{3}$	1	2.71	$\infty$
6	- System Detection Limits	B	1	R	$\sqrt{3}$	1	0.58	$\infty$
7	Modulation response	B	0	N	1	1	0.00	



8	- Readout Electronics	B	0.5	N	1	1	0.50	∞
9	- Response Time	B	0.00	R	$\sqrt{3}$	1	0.00	∞
10	- Integration Time	B	1.4	R	$\sqrt{3}$	1	0.81	∞
11	- RF Ambient Conditions	B	3.0	R	$\sqrt{3}$	1	1.73	∞
12	- Probe Position Mechanical tolerance	B	1.4	R	$\sqrt{3}$	1	0.81	∞
13	- Probe Position with respect to Phantom Shell	B	1.4	R	$\sqrt{3}$	1	0.81	∞
14	- Extrapolation, Interpolation and Integration Algorithms for Max. SAR evaluation	B	2.3	R	$\sqrt{3}$	1	1.33	∞
<b>Uncertainties of the DUT</b>								
15	Deviation of experimental source from numerical source	A	4	N	1	1	4.00	5
16	Input Power and SAR drift measurement	A	5	R	$\sqrt{3}$	1	2.89	5
17	Dipole Axis to Liquid Distance	B	2	R	$\sqrt{3}$	1	1.2	∞
<b>Phantom and Tissue Parameters</b>								
18	- Phantom Uncertainty(shape and thickness tolerances)	B	4	R	$\sqrt{3}$	1	2.31	∞
19	Uncertainty in SAR correction for deviation(in permittivity and conductivity)	B	2	N	1	1	2.00	
20	- Liquid Conductivity Target -tolerance	B	2.5	R	$\sqrt{3}$	0.6	1.95	∞
21	- Liquid Conductivity -measurement Uncertainty)	B	4	N	$\sqrt{3}$	1	0.92	9
22	- Liquid Permittivity Target tolerance	B	2.5	R	$\sqrt{3}$	0.6	1.95	∞
23	- Liquid Permittivity -measurement uncertainty	B	5	N	$\sqrt{3}$	1	1.15	∞
<b>Combined Standard Uncertainty</b>				RSS			10.15	
<b>Expanded uncertainty</b> (Confidence interval of 95 %)				K=2			20.29	

**12 MAIN TEST INSTRUMENTS**

<b>EQUIPMENT</b>	<b>TYPE</b>	<b>Series No.</b>	<b>Calibration Date</b>	<b>calibration period</b>
System Simulator	CMW500	130805	2016/08/10	1 Year
SAR Probe	SATIMO	SN43/15 EP276	2015/12/09	1 Year
Dipole	SID835	SN09/13 DIP0G835-217	2014/08/28	3 Year
Dipole	SID1800	SN09/13 DIP1G800-216	2014/08/28	3 Year
Dipole	SID1900	SN09/13 DIP1G900-218	2014/08/28	3 Year
Dipole	SID2450	SN09/13 DIP2G450-220	2014/08/28	3 Year
Dipole	SID2600	SN32/14 DIP2G600-338	2014/08/12	3 Year
Vector Network Analyzer	ZVB8	A0802530	2016/06/07	1 Year
Signal Generator	SMR27	A0304219	2016/06/07	1 Year
Power Meter	NRP2	A140401673	2016/03/09	1 Year
Power Sensor	NPR-Z11	1138.3004.02-114072-nq	2016/03/09	1 Year
Amplifier	Nucletudes	143060	2016/03/09	1 Year
Directional Coupler	DC6180A	305827	2016/03/09	1 Year
Power Meter	NRVS	A0802531	2016/03/09	1 Year
Power Sensor	NRV-Z4	100069	2016/03/09	1 Year
Multimeter	Keithley-2000	4014020	2016/03/09	1 Year