



FCC SAR TEST REPORT

Report No.: SET2015-16860
Product: Mobile phone
Brand Name: Haier
Model No.: L52\L50a
FCC ID: SG7201511L50
Applicant: Haier Telecom(Qingdao) CO., Ltd.
Address: No1.Haier Road,Hi-tech Zone Qingdao,China
Issued by: CCIC-SET
Lab Location: Electronic Testing Building, Shahe Road, Xili, Nanshan District, Shenzhen, 518055, P. R. China
Tel: 86 755 26627338 **Fax:** 86 755 26627238
Mail: manager@ccic-set.com **Website:** <http://www.ccic-set.com>

This test report consists of **193** pages in total. It may be duplicated completely for legal use with the approval of the applicant. It should not be reproduced except in full, without the written approval of our laboratory. The client should not use it to claim product endorsement by CCIC-SET. The test results in the report only apply to the tested sample. The test report shall be invalid without all the signatures of testing engineers, reviewer and approver. Any objections must be raised to CCIC-SET within 15 days since the date when the report is received. It will not be taken into consideration beyond this limit.



Test Report

Product: Mobile phone
Model No.: L52\L50a
Brand Name.....: Haier
FCC ID.....: SG7201511L50
Applicant.....: Haier Telecom(Qingdao) CO., Ltd.
Applicant Address.....: No1.Haier Road,Hi-tech Zone Qingdao,China
Manufacturer.....: Haier Telecom(Qingdao) CO., Ltd.
Manufacturer Address: No1.Haier Road,Hi-tech Zone Qingdao,China

Test Standards.....: **47CFR § 2.1093-** Radiofrequency Radiation Exposure Evaluation: Portable Devices;
ANSI C95.1-1992: Safety Levels with Respect to Human Exposure to Radio Frequency Electromagnetic Fields, 3 kHz – 300 GHz.(IEEE Std C95.1-1991)
IEEE 1528-2013: IEEE Recommended Practice for Determining the Peak Spatial-Average Specific Absorption Rate (SAR) in the Human Body Due to Wireless Communications Devices: Experimental Techniques;

Test Result.....: Pass

Tested by: Mei Chun 2015-11-27
Chun Mei, Test Engineer

Reviewed by.....: Shuangwen Zhang 2015-11-27
Shuangwen Zhang, Senior Engineer

Approved by.....: Wu Lian 2015-11-27
Wu Li'an , Manager



Contents

- 1. **GENERAL CONDITIONS**-----4
- 2. **ADMINISTRATIVE DATA**-----5
 - 2.1. Identification of the Responsible Testing Laboratory-----5
 - 2.2. Identification of the Responsible Testing Location(s)-----5
 - 2.3. Organization Item-----5
 - 2.4. Identification of Applicant-----5
 - 2.5. Identification of Manufacture-----5
- 3. **EQUIPMENT UNDER TEST (EUT)**-----6
- 4. **SAR SUMMAY**-----7
- 5. **Specific Absorption Rate(SAR)**-----9
 - 5.1. Introduction-----9
 - 5.2. SAR Definition-----9
 - 5.3. Phantoms-----10
 - 5.4. Device Holder-----10
 - 5.5. Probe Specification-----11
- 6. **OPERATIONAL CONDITIONS DURING TEST**-----12
 - 6.1. Schematic Test Configuration-----12
 - 6.2. SAR Measurement System-----12
 - 6.3. Equipments and results of validation testing-----15
 - 6.4. SAR measurement procedure-----17
 - 6.5. Antennas position and test position-----18
- 7. **CHARACTERISTICS OF THE TEST**-----19
 - 7.1. Applicable Limit Regulations-----19
 - 7.2. Applicable Measurement Standards-----19
- 8. **LABORATORY ENVIRONMENT**-----20
- 9. **CONDUCTED RF OUTPUT POWER**-----20
- 10. **TEST RESULTS**-----40
- 11. **MEASUREMENT UNCERTAINTY**-----47
- 12. **MAIN TEST INSTRUMENTS**-----50

This Test Report consists of the following Annexes:

Annex A: Test Layout -----	51
Annex B: Sample Photographs -----	59
Annex C: System Performance Check Data and Highest SAR Plots -----	61
Annex D: Calibration Certificate of Probe and Dipoles -----	99

1. GENERAL CONDITIONS

1.1 This report only refers to the item that has undergone the test.

1.2 This report standalone does not constitute or imply by its own an approval of the product by the certification Bodies or competent Authorities.

1.3 This document is only valid if complete; no partial reproduction can be made without written approval of CCIC-SET

1.4 This report cannot be used partially or in full for publicity and/or promotional purposes without previous written approval of CCIC-SET and the Accreditation Bodies, if it applies.



2. Administrative Date

2.1. Identification of the Responsible Testing Laboratory

Company Name: CCIC-SET

Department: EMC & RF Department

Address: Electronic Testing Building, Shahe Road, Nanshan District,
ShenZhen, P. R. China

Telephone: +86-755-26629676

Fax: +86-755-26627238

Responsible Test Lab Managers: Mr. Wu Li'an

2.2. Identification of the Responsible Testing Location(s)

Company Name: CCIC-SET

Address: Electronic Testing Building, Shahe Road, Nanshan District,
Shenzhen, P. R. China

2.3. Organization Item

CCIC-SET Report No.: SET2015-16860

CCIC-SET Project Leader: Mr. Li Sixiong

CCIC-SET Responsible for accreditation scope: Mr. Wu Li'an

Start of Testing: 2015-11-13

End of Testing: 2015-11-19

2.4. Identification of Applicant

Company Name: Haier Telecom(Qingdao) CO., Ltd.

Address: No1.Haier Road,Hi-tech Zone Qingdao,China

2.5. Identification of Manufacture

Company Name: Haier Telecom(Qingdao) CO., Ltd.

Address: No1.Haier Road,Hi-tech Zone Qingdao,China

Notes: This data is based on the information by the applicant.

3. Equipment Under Test (EUT)

3.1. Identification of the Equipment under Test

Sample Name: Mobile phone

Type Name: L52\L50a

Brand Name: Haier

	Support Band	GSM850MHz/1900MHz/900MHz/1800MHz WCDMA 850MHz/ 1700MHz/ 1900MHz, LTE Band2/3/4/7/17,WIFI, BT
	Test Band	GSM 850MHz/ GSM 1900MHz, GPRS 850MHz/ GPRS 1900MHz, WCDMA 850MHz/ 1700MHz/ 1900MHz, LTE Band 2/4/7/17, WIFI 802.11b
	Multislot Class	GPRS: Class 12 ; EDGE: Class 12
General	GPRS Class	Class B
description:	Development Stage	Identical Prototype
	Accessories	Power Supply
	Battery type	3.80V 2000mAh
	Antenna type	Inner Antenna
	Operation mode	GSM / GPRS /WCDMA/ LTE /WIFI
	Modulation mode	GSM(GMSK),UMTS(QPSK),LTE(QPSK,16QAM), WIFI(OFDM/DSSS)
	Max. RF Power	32.57dBm
	Max. SAR Value	Head: 0.497 W/kg; Body: 0.851 W/kg; Hotspot: 1.118 W/kg

NOTE:

- a. The above EUT's information was declared by manufacturer. Please refer to the specifications or user's manual for more detailed description.
- b. This device supports GPRS operation up to class12 (max.uplink:4, max.downlink:4, total timeslots:5). This device supports EDGE operation up to class12(max.uplink:4, max.downlink:4, total timeslots:5)



4 SAR SUMMARY

Highest Standalone SAR Summary

Exposure Position	Frequency Band	Scaled 1g-SAR(W/kg)	Highest Scaled 1g-SAR(W/kg)
Head	GSM850	0.057	0.497
	GSM1900	0.245	
	WCDMA Band II	0.173	
	WCMA Band IV	0.240	
	WCDMA Band V	0.054	
	LTE Band 2	0.166	
	LTE Band 4	0.185	
	LTE Band 7	0.075	
	LTE Band 17	0.079	
	WIFI	0.497	
Body-worn Accessory (10mm Gap)	GSM850	0.086	0.851
	GSM1900	0.255	
	WCDMA Band II	0.428	
	WCMA Band IV	0.716	
	WCDMA Band V	0.122	
	LTE Band 2	0.438	
	LTE Band 4	0.666	
	LTE Band 7	0.851	
	LTE Band 17	0.151	
	WIFI	0.103	
Hotspot Accessory (10mm Gap)	GSM850	0.101	1.118
	GSM1900	0.405	
	WCDMA Band II	0.828	
	WCMA Band IV	0.716	
	WCDMA Band V	0.122	
	LTE Band 2	0.665	
	LTE Band 4	0.666	
	LTE Band 7	1.118	
	LTE Band 17	0.151	
	WIFI	0.103	



Highest Simultaneous SAR Summary

Exposure Position	Frequency Band	Scaled 1g-SAR(W/kg)	Highest Scaled 1g-SAR(W/kg)
Head	GSM850&WIFI	0.039+0.497	0.654
	GSM1900&WIFI	0.245+0.377	
	WCDMA Band II &WIFI	0.089+0.497	
	WCDMA Band IV &WIFI	0.157+0.497	
	WCDMA Band V &WIFI	0.031+0.497	
	LTE Band 2&WIFI	0.085+0.497	
	LTE Band 4&WIFI	0.122+0.497	
	LTE Band 7&WIFI	0.048+0.497	
	LTE Band 17&WIFI	0.055+0.497	
Body-worn Accessory (10mm Gap)	GSM850&WIFI	0.086+0.103	0.954
	GSM1900&WIFI	0.255+0.103	
	WCDMA Band II &WIFI	0.414+0.103	
	WCDMA Band IV &WIFI	0.716+0.103	
	WCDMA Band V &WIFI	0.122+0.103	
	LTE Band 2&WIFI	0.438+0.103	
	LTE Band 4&WIFI	0.666+0.103	
	LTE Band 7&WIFI	0.851+0.103	
	LTE Band 17&WIFI	0.151+0.103	
Hotspot Accessory (10mm Gap)	GSM850&WIFI	0.101+0.103	1.118
	GSM1900&WIFI	0.405	
	WCDMA Band II &WIFI	0.828	
	WCDMA Band IV &WIFI	0.716+0.103	
	WCDMA Band V &WIFI	0.122+0.103	
	LTE Band 2&WIFI	0.665	
	LTE Band 4&WIFI	0.666+0.103	
	LTE Band 7&WIFI	1.118	
LTE Band 17&WIFI	0.151+0.103		

5 Specific Absorption Rate (SAR)

5.1 Introduction

SAR is related to the rate at which energy is absorbed per unit mass in an object exposed to a radio field. The SAR distribution in a biological body is complicated and is usually carried out by experimental techniques or numerical modeling. The standard recommends limits for two tiers of groups, occupational/controlled and general population/uncontrolled, based on a person's awareness and ability to exercise control over his or her exposure. In general, occupational/controlled exposure limits are higher than the limits for general population/uncontrolled.

5.2 SAR Definition

The SAR definition is the time derivative (rate) of the incremental energy (dW) absorbed by (dissipated in) an incremental mass (dm) contained in a volume element (dv) of a given density (ρ). The equation description is as below:

$$\text{SAR} = \frac{d}{dt} \left(\frac{dW}{dm} \right) = \frac{d}{dt} \left(\frac{dW}{\rho dv} \right)$$

SAR is expressed in units of Watts per kilogram (W/kg)

SAR measurement can be either related to the temperature elevation in tissue by

$$\text{SAR} = C \frac{\delta T}{\delta t}$$

where C is the specific heat capacity, δT is the temperature rise and δt the exposure duration, or related to the electrical field in the tissue by

$$\text{SAR} = \frac{\sigma |E|^2}{\rho}$$

where σ is the conductivity of the tissue, ρ is the mass density of the tissue and E is the rms electrical field strength.

However for evaluating SAR of low power transmitter, electrical field measurement is typically applied.

5.3 Phantoms

The phantom used for all tests i.e. for both system checks and device testing, was the twin-headed "SAM Phantom", manufactured by SATIMO. The SAM twin phantom is a fiberglass shell phantom with 2mm shell thickness (except the ear region, where shell thickness increases to 6mm).

System checking was performed using the flat section, whilst Head SAR tests used the left and right head profile sections. Body SAR testing also used the flat section between the head profiles.



SAM Twin Phantom

5.4 Device Holder

The device was placed in the device holder (illustrated below) that is supplied by SATIMO as an integral part of the COMOSAR test system.

The device holder is designed to cope with the different positions given in the standard. It has two scales for device rotation (with respect to the body axis) and device inclination (with respect to the line between the ear reference points). The rotation centers for both scales is the ear reference point (ERP). Thus the device needs no repositioning when changing the angles.

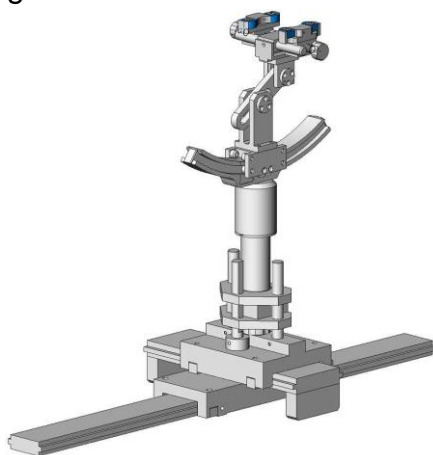

Device holder

5.5 Probe Specification



Construction	Symmetrical design with triangular core Interleaved sensors Built-in shielding against static charges PEEK enclosure material (resistant to organic solvents, e.g., DGBE)
Calibration	ISO/IEC 17025 calibration service available.
Frequency	700 MHz to 3 GHz; Linearity: ± 0.5 dB (700 MHz to 3 GHz)
Directivity	± 0.25 dB in HSL (rotation around probe axis) ± 0.5 dB in tissue material (rotation normal to probe axis)
Dynamic Range	1.5 μ W/g to 100 mW/g; Linearity: ± 0.5 dB
Dimensions	Overall length: 330 mm (Tip: 20 mm) Tip diameter: 5 mm Distance from probe tip to dipole centers: <2.7 mm
Application	General dosimetry up to 3 GHz Dosimetry in strong gradient fields Compliance tests of mobile phones
Compatibility	COMOSAR

Isotropic E-Field Probe

The isotropic E-Field probe has been fully calibrated and assessed for isotropicity, and boundary effect within a controlled environment. Depending on the frequency for which the probe is calibrated the method utilized for calibration will change.

The E-Field probe utilizes a triangular sensor arrangement as detailed in the diagram below:

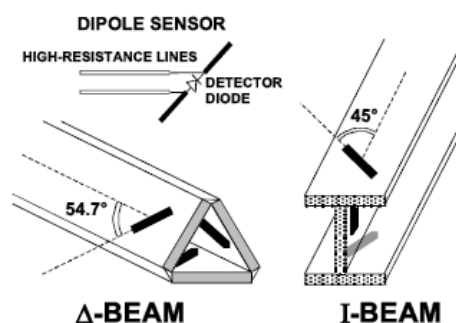

6 OPERATIONAL CONDITIONS DURING TEST

6.1 Schematic Test Configuration

During SAR test, EUT was operating in Traffic Mode (Channel Allocated) at Normal Voltage Condition. A communication link is set up with a System Simulator (SS) by air link, and a call is established. The EUT was commanded to operate at maximum transmitting power.

The EUT should use its internal transmitter. The antenna(s), battery and accessories shall be those specified by the manufacturer. The EUT battery must be fully charged and checked periodically during the test to ascertain uniform power output. If a wireless link was used, the antenna connected to the output of the base station simulator shall be placed at least 50 cm away from the handset.

The signal transmitted by the simulator to the antenna feeding point should be lower than the output power level of the handset by at least 35 dB

6.2 SAR Measurement System

The SAR measurement system being used is the SATIMO system, the system is controlled remotely from a PC, which contains the software to control the robot and data acquisition equipment. The software also displays the data obtained from test scans.

In operation, the system first does an area (2D) scan at a fixed depth within the liquid from the inside wall of the phantom. When the maximum SAR point has been found, the system will then carry out a 3D scan centred at that point to determine volume averaged SAR level.

6.2.1 Tissue Dielectric Parameters for Head and Body Phantoms

The head tissue dielectric parameters recommended by the IEEE SCC-34/SC-2 in P1528 have been incorporated in the following table. These head parameters are derived from planar layer models simulating the highest expected SAR for the dielectric properties and tissue thickness Power drifts in a human head. Other head and body tissue parameters that have not been specified in P1528 are derived from the tissue dielectric parameters computed from the 4-Cole-Cole equations described in Reference [12] and extrapolated according to the head parameters specified in P1528.

Table 1: Recommended Dielectric Performance of Tissue

Ingredients (% by weight)	Frequency (MHz)											
	450		835		915		1900		2450		2600	
Tissue Type	Head	Body	Head	Body	Head	Body	Head	Body	Head	Body	Head	Body
Water	38.56	51.16	41.46	52.4	41.05	56.0	54.9	40.4	62.7	73.2	55.24	64.49
Salt (Nacl)	3.95	1.49	1.45	1.4	1.35	0.76	0.18	0.5	0.5	0.04	0.5	0.024
Sugar	56.32	46.78	56.0	45.0	56.5	41.76	0.0	58.0	0.0	0.0	0.0	0.0
HEC	0.98	0.52	1.0	1.0	1.0	1.21	0.0	1.0	0.0	0.0	0.0	0.0



Bactericide	0.19	0.05	0.1	0.1	0.1	0.27	0.0	0.1	0.0	0.0	0.0	0.0
Triton x-100	0.0	0.0	0.0	0.0	0.0	0.0	0.0	0.0	36.8	0.0	44.45	32.25
DGBE	0.0	0.0	0.0	0.0	0.0	0.0	44.92	0.0	0.0	26.7	0.0	26.7
Dielectric Constant	43.42	58.0	42.54	56.1	42.0	56.8	39.9	54.0	39.8	52.5	39.0	52.5
Conductivity (s/m)	0.85	0.83	0.91	0.95	1.0	1.07	1.42	1.45	1.88	1.78	1.96	2.16

MSL/HSL750 (Body and Head liquid for 700 – 800 MHz)

Item	Head Tissue Simulation Liquid HSL750 Muscle(body)Tissue Simulation Liquid MSL750			
H2O	Water, 35 – 58%			
Sucrose	Sugar, white, refined, 40-60%			
NaCl	Sodium Chloride, 0-6%			
Hydroxyethyl-cellulose	Medium Viscosity (CAS# 9004-62-0), <0.3%			
Preventol-D7	Preservative: aqueous preparation, (CAS# 55965-84-9), containing 5-chloro-2-methyl-3(2H)-isothiazolone and 2-methyl-3(2H)-isothiazolone, 0.1-0.7%			
Frequency (MHz)	Head ϵ_r	Head σ (S/m)	Body ϵ_r	Body σ (S/m)
750	41.9	0.89	55.2	0.97

Note: The liquid of 700MHz&2600MHz typical liquid composition is provided by SATIMO.

Table 2 Recommended Tissue Dielectric Parameters

Frequency (MHz)	Head Tissue		Body Tissue	
	ϵ_r	σ (S/m)	ϵ_r	σ (S/m)
150	52.3	0.76	61.9	0.80
300	45.3	0.87	58.2	0.92
450	43.5	0.87	56.7	0.94
835	41.5	0.90	55.2	0.97
900	41.5	0.97	55.0	1.05
915	41.5	0.98	55.0	1.06
1450	40.5	1.20	54.0	1.30
1610	40.3	1.29	53.8	1.40
1800-2000	40.0	1.40	53.3	1.52
2450	39.2	1.80	52.7	1.95
3000	38.5	2.40	52.0	2.73
5800	35.3	5.27	48.2	6.00

6.2.2 Stimulate liquid

For measurements against the phantom head, the “cheek” and “tilt” position on both the left hand and the right hand sides of the phantom. For body-worn measurements, the EUT was tested against flat phantom representing the user body. The EUT was put on in the belt holder. Stimulate liquid that are used for testing at frequencies of GSM 850MHz/1900MHz, WCDMA850MHz/1700MHz/1900MHz, LTE Band2/4/7/17 and Wi-Fi 2.4GHz, which are made mainly of sugar, salt and water solutions may be left in the phantoms.

Table 3: Dielectric Performance of Head Tissue Simulating Liquid

Temperature: 23.2°C; Humidity: 64%;			
/	Frequency	Permittivity ϵ	Conductivity σ (S/m)
Target value	750MHz	41.9±5%	0.89±5%
Validation value (Nov. 13th, 2015)	750MHz	41.71	0.88
Target value	850MHz	41.5±5%	0.90±5%
Validation value (Nov. 13th, 2015)	850MHz	41.36	0.88
Target value	1800 MHz	40.0±5%	1.40±5%
Validation value (Nov. 14th, 2015)	1800 MHz	39.75	1.39
Target value	1900MHz	40.0±5%	1.40±5%
Validation value (Nov. 14th, 2015)	1900MHz	39.85	1.39
Target value	2450MHz	39.2±5%	1.80±5%
Validation value (Nov. 16th, 2015)	2450MHz	38.94	1.79
Target value	2600MHz	39.0±5%	1.96±5%
Validation value (Nov. 16th, 2015)	2600MHz	38.89	1.93

Table 4: Dielectric Performance of Body Tissue Simulating Liquid

Temperature: 23.2°C; Humidity: 64%;			
/	Frequency	Permittivity ϵ	Conductivity σ (S/m)
Target value	750MHz	55.2±5%	0.97±5%
Validation value (Nov. 17th, 2015)	750MHz	55.01	0.95
Target value	850MHz	55.2±5%	0.97±5%
Validation value (Nov. 17th, 2015)	850MHz	55.32	0.95
Target value	1800 MHz	53.3±5%	1.52±5%
Validation value (Nov. 18th, 2015)	1800 MHz	53.37	1.50
Target value	1900MHz	53.3±5%	1.52±5%
Validation value (Nov. 18th, 2015)	1900MHz	53.14	1.52
Target value	2450MHz	52.7±5%	1.95±5%
Validation value (Nov. 19th, 2015)	2450MHz	52.53	1.94
Target value	2600MHz	52.5±5%	2.16±5%
Validation value (Nov. 19th, 2015)	2600MHz	52.56	2.15

6.3 Results of validation testing

Prior to the assessment, the system validation kit was used to test whether the system was operating within its specifications of $\pm 10\%$. The validation results are tabulated below. And also the corresponding SAR plot is attached as well in the SAR plots files.

The following procedure, recommended for performing validation tests using box phantoms is based on the procedures described in the IEEE standard P1528. Setup according to the setup diagram below :

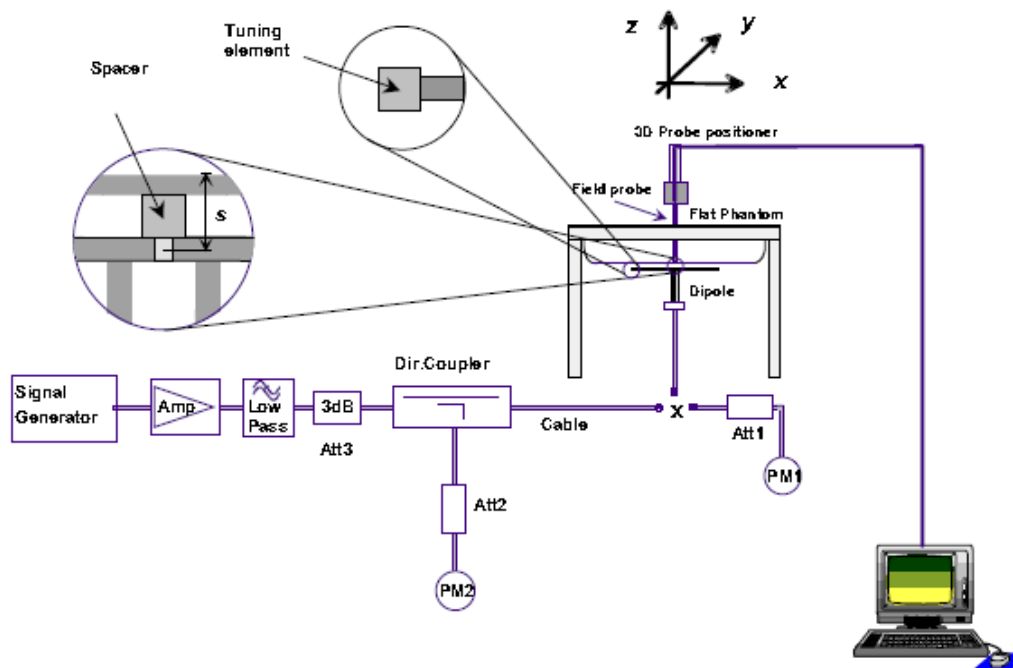

With the SG and Amp and with directional coupler in place, set up the source signal at the relevant frequency and use a power meter to measure the power at the end of the SMA cable that you intend to connect to the balanced dipole. Adjust the SG to make this, say, 0.25W (24 dBm). If this level is too high to read directly with the power meter sensor, insert a calibrated attenuator (e.g. 10 or 20 dB) and make a suitable correction to the power meter reading.

Note 1: In this method, the directional coupler is used for monitoring rather than setting the exact feed power level. If, however, the directional coupler is used for power measurement, you should check the frequency range and power rating of the coupler and measure the coupling factor (referred to output) at the test frequency using a VNA.

Note 2: Remember that the use of a 3dB attenuator (as shown in Figure 8.1 of P1528) means that you need an RF amplifier of 2 times greater power for the same feed power. The other issue is the cable length. You might get up to 1dB of loss per meter of cable, so the cable length after the coupler needs to be quite short.

Note 3: For the validation testing done using CW signals, most power meters are suitable. However, if you are measuring the output of a modulated signal from either a signal generator or a handset, you must ensure that the power meter correctly reads the modulated signals.

The measured 1-gram averaged SAR values of the device against the phantom are provided in Tables 5 and Table 6. The humidity and ambient temperature of test facility were 64% and 23.2°C respectively. The body phantom were full of the body tissue simulating liquid. The EUT was supplied with full-charged battery for each measurement.

The distance between the back of the EUT and the bottom of the flat phantom is 10 mm (taking into account of the IEEE 1528 and the place of the antenna).

Table 5: Head SAR system validation (1g)

Frequency	Duty cycle	Target value (W/kg)	Test value (W/kg)	
			250 mW	1W
750MHz(Nov. 13th, 2015)	1:1	8.67 ± 10%	2.10	8.40
835MHz(Nov. 13th, 2015)	1:1	9.77 ± 10%	2.40	9.60
1800MHz(Nov. 14th, 2015)	1:1	38.67 ± 10%	9.47	37.88
1900MHz(Nov. 14th, 2015)	1:1	40.37 ± 10%	9.85	39.40
2450MHz(Nov. 16th, 2015)	1:1	53.60 ± 10%	13.16	52.64
2600MHz((Nov. 16th, 2015)	1:1	56.19 ± 10%	13.94	55.76

Table 6: Body SAR system validation (1g)

Frequency	Duty cycle	Target value (W/kg)	Test value (W/kg)	
			250 mW	1W
750MHz(Nov. 17th, 2015)	1:1	8.43 ± 10%	2.01	8.04
835MHz(Nov. 17th, 2015)	1:1	10.31 ± 10%	2.52	10.08
1800MHz(Nov. 18th, 2015)	1:1	40.07 ± 10%	9.83	39.32
1900MHz(Nov. 18th, 2015)	1:1	40.81 ± 10%	10.11	40.44
2450MHz(Nov. 19th, 2015)	1:1	52.66 ± 10%	13.06	52.24
2600MHz((Nov. 19th, 2015)	1:1	57.55 ± 10%	14.03	56.12

* Note: Target value was referring to the measured value in the calibration certificate of reference dipole.
 Note: All SAR values are normalized to 1W forward power.

6.4 SAR measurement procedure

The SAR test against the head phantom was carried out as follow:

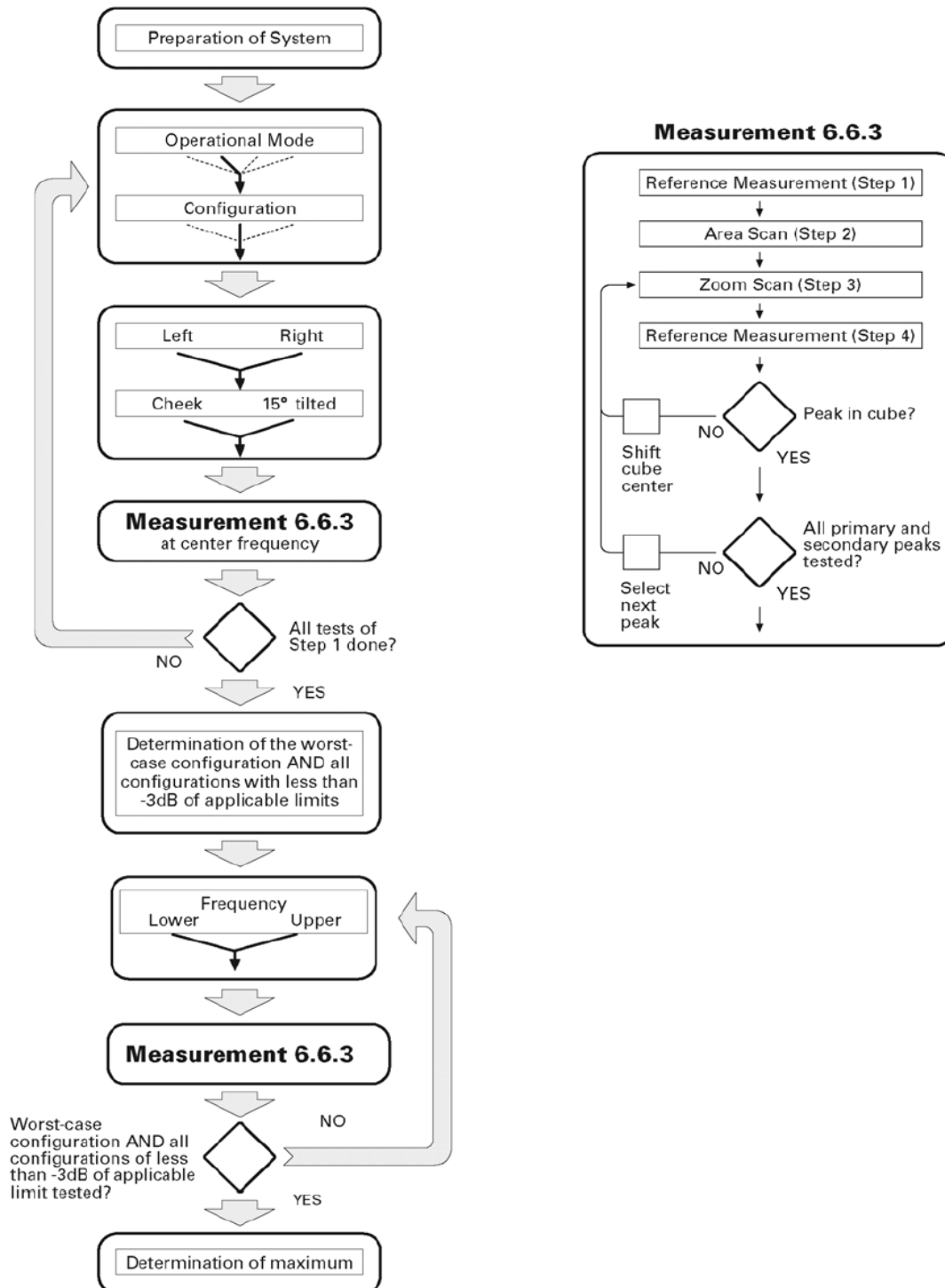

Establish a call with the maximum output power with a base station simulator, the connection between the EUT and the base station simulator is established via air interface.

After an area scan has been done at a fixed distance of 2mm from the surface of the phantom on the source side, a 3D scan is set up around the location of the maximum spot SAR. First, a point within the scan area is visited by the probe and a SAR reading taken at the start of testing. At the end of testing, the probe is returned to the same point and a

second reading is taken. Comparison between these start and end readings enables the power drift during measurement to be assessed.

Above is the scanning procedure flow chart and table from the IEEE p1528 standard. This is the procedure for which all compliant testing should be carried out to ensure that all variations of the device position and transmission behavior are tested.

For body-worn measurement, the EUT was tested under two position: face upward and back upward.

6.5 Transmitting antenna information

The GSM&WCDMA<E&WIFI&BT antennas inside the EUT.

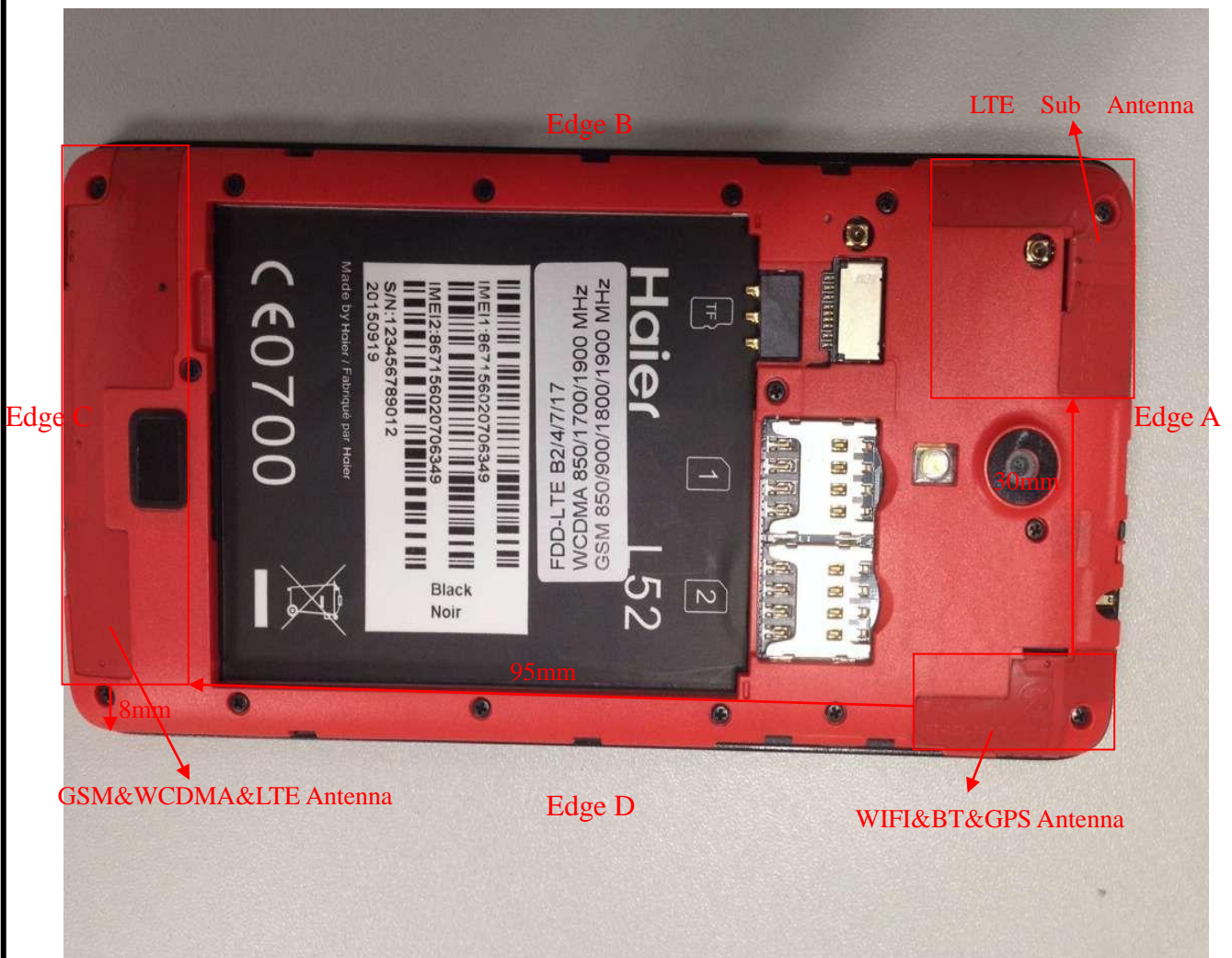

Fig. 3 Position of the antennas



The Body SAR measurement positions of each band are as below:

Antenna	Front	Back	Edge A	Edge B	Edge C	Edge D
2G /3G /4G Antenna Body-worn	Yes	Yes	No	No	No	No
2G /3G /4G Antenna hotspot	Yes	Yes	No	Yes	Yes	Yes
WIFI Antenna Body-worn	Yes	Yes	No	No	No	No
WIFI Antenna hotspot	Yes	Yes	Yes	No	No	Yes

Note: According to KDB941225 antenna-to-edge>2.5cm, SAR is not required.

7 CHARACTERISTICS OF THE TEST

7.1 Applicable Limit Regulations

47CFR § 2.1093- Radiofrequency Radiation Exposure Evaluation: Portable Devices;

ANSI C95.1–1992: Safety Levels with Respect to Human Exposure to Radio Frequency Electromagnetic Fields, 3 kHz – 300 GHz.(IEEE Std C95.1-1991)

IEEE 1528–2013: IEEE Recommended Practice for Determining the Peak Spatial-Average Specific Absorption Rate (SAR) in the Human Body Due to Wireless Communications Devices: Experimental Techniques;

It specifies the maximum exposure limit of **1.6 W/kg** as averaged over any 1 gram of tissue for portable devices being used within 20 cm of the user in the uncontrolled environment.

7.2 Applicable Measurement Standards

The Specific Absorption Rate (SAR) testing specification, method, and procedure for this is in accordance with the following standards:

FCC 47 CFR Part2 (2.1093)

ANSI/IEEE C95.1-1992

IEEE 1528-2013

FCC KDB 248227 D01 802.11 Wi-Fi SAR v02r02

FCC KDB 447498 D01 v06 General RF Exposure Guidance

FCC KDB 648474 D04 v01r03 Handset SAR

FCC KDB 865664 D01 v01r04 SAR Measurement 100MHz to 6GHz

FCC KDB 865664 D02 v01r02 SAR Exposure Reporting

FCC KDB 941225 D01 v03r01 3G SAR Procedures

FCC KDB 941225 D05 v02r04 SAR for LTE Devices

FCC KDB 941225 D06 v02r01 Hotspot Mode

8 LABORATORY ENVIRONMENT

The Ambient Conditions during SAR Test

Temperature	Min. = 22 ° C, Max. = 25 ° C
Atmospheric pressure	Min.=86 kPa, Max.=106 kPa
Relative humidity	Min. = 45%, Max. = 75%
Ground system resistance	< 0.5 Ω

Ambient noise is checked and found very low and in compliance with requirement of standards. Reflection of surrounding objects is minimized and in compliance with requirement of standards.

9. Conducted RF Output Power

9.1 GSM Conducted Power

GSM Conducted Power

Band		Burst Average Power (dBm)			Frame-Average Power (dBm)		
GSM850	TX Channel	128	190	251	128	190	251
	Frequency(MHz)	824.2	836.4	848.8	824.2	836.4	848.8
	GSM	32.56	32.55	32.57	23.53	23.52	23.54
	GPRS (Slot 1)	32.43	32.43	32.44	23.40	23.40	23.41
	GPRS (Slot 2)	29.50	29.52	29.55	23.3	23.25	23.33
	GPRS (Slot 3)	27.88	27.86	27.91	23.56	23.59	23.58
	GPRS (Slot 4)	25.87	25.90	25.93	22.96	22.92	22.95
	EDGE (Slot 1)	32.47	32.49	32.50	23.44	23.46	23.47
	EDGE (Slot 2)	28.87	28.79	28.84	22.65	22.69	22.70
	EDGE (Slot 3)	26.67	26.72	26.70	22.27	22.35	22.31
	EDGE (Slot 4)	25.21	25.23	25.24	22.14	22.21	22.17
GSM1900	TX Channel	512	661	810	512	661	810
	Frequency(MHz)	1850.2	1880	1909.8	1850.2	1880	1909.8
	GSM	28.96	29.00	29.18	19.93	19.97	20.15
	GPRS (Slot 1)	28.85	28.94	29.06	19.82	19.91	20.03
	GPRS (Slot 2)	27.21	27.17	27.18	21.33	21.39	21.36
	GPRS (Slot 3)	25.82	25.81	25.84	21.61	21.65	21.67
	GPRS (Slot 4)	24.05	24.11	24.04	21.17	21.22	21.25



EDGE (Slot 1)	28.90	28.97	29.12	19.87	19.94	20.09
EDGE (Slot 2)	26.87	26.90	26.89	20.73	20.76	20.79
EDGE (Slot 3)	25.37	25.41	25.38	20.99	21.11	21.08
EDGE (Slot 4)	23.92	23.89	23.91	20.86	20.88	20.84

Note:Per KDB 447498 D01 v06, the maximum output power channel is used for SAR testing and for further SAR test reduction.

For Head SAR testing, GSM should be evaluated, therefore the EUT was set in GSM Voice for GSM850 and GSM1900 due to its highest frame-average power.

For Body worn SAR testing, GSM should be evaluated, therefore the EUT was set in GSM Voice for GSM850 and GSM 1900 due to its highest frame-average power.

For hotspot mode SAR testing, GPRS and EDGE should be evaluated, therefore the EUT was set in GPRS850 (3Tx slots) and GPRS1900 (3Tx slots) due to its highest frame-average power.

Timeslot consignations

No. Of Slots	Slot 1	Slot 2	Slot 3	Slot 4
Slot Consignation	1Up4Down	2Up3Down	3Up2Down	4Up1Down
Duty Cycle	1:8	1:4	1:2.67	1:2
Crest Factor	-9.03dB	-6.02dB	-4.26dB	-3.01dB

9.2 WCDMA Conducted peak output Power

WCDMA conducted peak output power

Item	band	WCDMA 850			WCDMA 1700			WCDMA 1900		
	ARFCN	4132	4183	4233	1312	1413	1513	9262	9400	9538
	subtest	dBm			dBm			dBm		
RMC 12.2kbps	non	22.95	22.76	22.89	22.50	22.45	22.41	22.66	22.50	22.73
HSDPA	1	22.46	22.52	22.54	22.01	21.93	21.95	22.31	22.24	22.39
	2	22.54	22.47	22.45	21.96	22.05	21.93	22.43	22.37	22.54
	3	22.41	22.56	22.59	22.09	21.94	22.06	22.35	22.26	22.47
	4	21.79	21.69	21.72	22.05	21.96	21.98	21.87	21.84	21.91
HSUPA	1	22.39	22.37	22.45	22.22	22.13	22.11	22.24	22.29	22.38
	2	21.96	21.81	21.82	21.91	21.96	21.85	21.88	21.76	21.79
	3	22.29	22.24	22.32	22.03	21.95	21.96	22.13	22.09	22.19
	4	21.71	21.69	21.59	21.87	21.88	21.79	21.69	21.51	21.55
	5	22.12	22.26	22.18	22.02	22.01	21.98	22.01	21.98	22.05
Note:	The Conducted RF Output Power test of WCDMA /HSDPA /HSUPA were tested by power meter.									

HSUPA Setup Configuration:

- a. The EUT was connected to Base Station Agilent E5515C referred to the Setup Configuration.
- b. The RF path losses were compensated into the measurements.
- c. A call was established between EUT and Base Station with following setting * :
 - i. Call Configs = 5.2B, 5.9B, 5.10B, and 5.13.2B with QPSK
 - ii. Set the Gain Factors (β_c and β_d) and parameters (AG Index) were set according to each specific sub-test in the following table, C11.1.3, quoted from the TS 34.121
 - iii. Set Cell Power = -86 dBm
 - iv. Set Channel Type = 12.2k + HSPA
 - v. Set UE Target Power
 - vi. Power Ctrl Mode= Alternating bits
 - vii. Set and observe the E-TFCI
 - viii. Confirm that E-TFCI is equal to the target E-TFCI of 75 for sub-test 1, and other subtest's E-TFCI
- d. The transmitted maximum output power was recorded.

Table C.11.1.3: β values for transmitter characteristics tests with HS-DPCCH and E-DCH

Sub-test	β_c	β_d	β_d (SF)	β_c/β_d	β_{HS} (Note 1)	β_{ec}	β_{ed} (Note 5) (Note 6)	β_{ed} (SF)	β_{ed} (Codes)	CM (dB) (Note 2)	MPR (dB) (Note 2)	AG Index (Note 6)	E- TFCI
1	11/15 (Note 3)	15/15 (Note 3)	64	11/15 (Note 3)	22/15	209/25	1309/225	4	1	1.0	0.0	20	75
2	6/15	15/15	64	6/15	12/15	12/15	94/75	4	1	3.0	2.0	12	67
3	15/15	9/15	64	15/9	30/15	30/15	β_{ed1} : 47/15 β_{ed2} : 47/15	4 4	2	2.0	1.0	15	92
4	2/15	15/15	64	2/15	4/15	2/15	56/75	4	1	3.0	2.0	17	71
5	15/15 (Note 4)	15/15 (Note 4)	64	15/15 (Note 4)	30/15	24/15	134/15	4	1	1.0	0.0	21	81

Note 1: Δ_{ACK} , Δ_{NACK} and $\Delta_{CQI} = 30/15$ with $\beta_{HS} = 30/15 * \beta_c$.

Note 2: CM = 1 for $\beta_c/\beta_d=12/15$, $\beta_{HS}/\beta_c=24/15$. For all other combinations of DPDCH, DPCCH, HS- DPCCH, E-DPDCH and E-DPCCH the MPR is based on the relative CM difference.

Note 3: For subtest 1 the β_c/β_d ratio of 11/15 for the TFC during the measurement period (TF1, TF0) is achieved by setting the signalled gain factors for the reference TFC (TF1, TF1) to $\beta_c = 10/15$ and $\beta_d = 15/15$.

Note 4: For subtest 5 the β_c/β_d ratio of 15/15 for the TFC during the measurement period (TF1, TF0) is achieved by setting the signalled gain factors for the reference TFC (TF1, TF1) to $\beta_c = 14/15$ and $\beta_d = 15/15$.

Note 5: In case of testing by UE using E-DPDCH Physical Layer category 1, Sub-test 3 is omitted according to TS25.306 Table 5.1g.

Note 6: β_{ed} can not be set directly, it is set by Absolute Grant Value.

Setup Configuration

HS-DPA Setup Configuration:

- a. The EUT was connected to Base Station Agilent E5515C referred to the Setup Configuration.
- b. The RF path losses were compensated into the measurements.
- c. A call was established between EUT and Base Station with following setting:
 - i. Set Gain Factors (β_c and β_d) and parameters were set according to each
 - ii. Specific sub-test in the following table, C10.1.4, quoted from the TS 34.121
 - iii. Set RMC 12.2Kbps + HSDPA mode.
 - iv. Set Cell Power = -86 dBm
 - v. Set HS-DSCH Configuration Type to FRC (H-set 1, QPSK)
 - vi. Select HSDPA Uplink Parameters
 - vii. Set Delta ACK, Delta NACK and Delta CQI = 8
 - viii. Set Ack-Nack Repetition Factor to 3
 - ix. Set CQI Feedback Cycle (k) to 4 ms
 - x. Set CQI Repetition Factor to 2
 - xi. Power Ctrl Mode = All Up bits
- d. The transmitted maximum output power was recorded.

Table C.10.1.4: β values for transmitter characteristics tests with HS-DPCCH

Sub-test	β_c	β_d	β_d (SF)	β_c/β_d	β_{HS} (Note 1, Note 2)	CM (dB) (Note 3)	MPR (dB) (Note 3)
1	2/15	15/15	64	2/15	4/15	0.0	0.0
2	12/15 (Note 4)	15/15 (Note 4)	64	12/15 (Note 4)	24/15	1.0	0.0
3	15/15	8/15	64	15/8	30/15	1.5	0.5
4	15/15	4/15	64	15/4	30/15	1.5	0.5

Note 1: Δ_{ACK} , Δ_{NACK} and $\Delta_{CQI} = 30/15$ with $\beta_{HS} = 30/15 * \beta_c$.

Note 2: For the HS-DPCCH power mask requirement test in clause 5.2C, 5.7A, and the Error Vector Magnitude (EVM) with HS-DPCCH test in clause 5.13.1A, and HSDPA EVM with phase discontinuity in clause 5.13.1AA, Δ_{ACK} and $\Delta_{NACK} = 30/15$ with $\beta_{HS} = 30/15 * \beta_c$, and $\Delta_{CQI} = 24/15$ with $\beta_{HS} = 24/15 * \beta_c$.

Note 3: CM = 1 for $\beta_c/\beta_d = 12/15$, $\beta_{HS}/\beta_c = 24/15$. For all other combinations of DPDCH, DPCCH and HS-DPCCH the MPR is based on the relative CM difference. This is applicable for only UEs that support HSDPA in release 6 and later releases.

Note 4: For subtest 2 the β_c/β_d ratio of 12/15 for the TFC during the measurement period (TF1, TF0) is achieved by setting the signalled gain factors for the reference TFC (TF1, TF1) to $\beta_c = 11/15$ and $\beta_d = 15/15$.

Note:

1. WCDMA SAR was tested under PMC 12.2kbps with HSPA Inactive per KDB Publication 941225 D01. HSPA SAR was not required since the average output power of the HSPA subtests was not more than 0.25dB higher than the RMC level and SAR was less than 1.2W/kg.
2. It is expected by the manufacturer that MPR for some HSPA subtests may be up to 2dB more than specified by 3GPP, but also as low as 0dB according to the chipset implementation in this model.

9.3 LTE Conducted peak output Power

LTE Test Configurations

The CMW500 WideBand Radio Communication Tester was used for LTE output power measurements and SAR testing. Closed loop power control was used so the UE transmits with maximum output power during SAR testing. SAR test were performed with the same number of RB and RB offsets transmitting on all frames.

1) Spectrum Plots for RB configurations

A properly configured base station simulator was used for LTE output power measurements and SAR testing. Therefore, spectrum plots for RB configurations were not required to be included in this report.

2) MPR

When MPR is implemented permanently within the UE, regardless of network requirements, only those RB configurations allowed by 3GPP for the channel bandwidth and modulation combinations may be tested with MPR active. Configurations with RB allocations less than the RB thresholds required by 3GPP must be tested without MPR.

The allowed Maximum Power Reduction (MPR) for the maximum output power due to higher order modulation and transmit bandwidth configuration (resource blocks) is specified in Table 6.2.3-1 of the 3GPP TS36.101:

Table 6.2.3-1: Maximum Power Reduction (MPR) for Power Class 3

Modulation	Channel bandwidth / Transmission bandwidth configuration [RB]						MPR (dB)
	1.4 MHz	3.0 MHz	5 MHz	10 MHz	15 MHz	20 MHz	
QPSK	> 5	> 4	> 8	> 12	> 16	> 18	≤ 1
16 QAM	≤ 5	≤ 4	≤ 8	≤ 12	≤ 16	≤ 18	≤ 1
16 QAM	> 5	> 4	> 8	> 12	> 16	> 18	≤ 2

3)A-MPR LTE procedures for SAR testing

A-MPR(Additional MPR) has been disabled for all SAR tests by using Network Signalling Value of “NS_01” on the base station simulator.

4)LTE procedures for SAR testing

A) Largest channel bandwidth standalone SAR test

requirements i) QPSK with 1 RB allocation

Start with the largest channel bandwidth and measure SAR for QPSK with 1 RB allocation, using the RB offset and required test channel combination with the highest maximum output power for RB offsets at the upper edge, middle and lower edge of each required test channel. When the reported SAR is $\leq 0.8\text{W/kg}$, testing of the remaining RB offset configurations and required test channels is not required for 1RB allocation; otherwise, SAR is required for the remaining required test channels and only for the RB offset configuration with the highest output power for that channel. When the reported SAR of a required test channel is $> 1.45\text{ W/kg}$, SAR is required for all three RB offset configurations for that required test channel.

ii) QPSK with 50% RB allocation

The procedures required for 1 RB allocation in i) are applied to measure the SAR for QPSK with 50% RB allocation.

iii) QPSK with 100% RB allocation

For QPSK with 100% RB allocation, SAR is not required when the highest maximum output power for 100 % RB allocation is less than the highest maximum output power in 50% and 1 RB allocations and the highest reported SAR for 1 RB and 50% RB allocation in i) and ii) are $\leq 0.8\text{ W/kg}$. Otherwise, SAR is measured for the highest output power channel and if the reported SAR is $> 1.45\text{ W/kg}$, the remaining required test channels must also be tested.

iv) Higher order modulations

For each modulation besides QPSK; e.g., 16-QAM, 64-QAM, apply the QPSK procedures in above sections to determine the QAM configurations that may need SAR measurement. For each configuration identified as required for testing, SAR is required only when the highest maximum output power for the configuration in the higher order modulation is $> \frac{1}{2}\text{ dB}$ higher than the same configuration in QPSK or when the reported SAR for the QPSK configuration is $> 1.45\text{ W/kg}$.

B) Other channel bandwidth standalone SAR test requirements

For the other channel bandwidths used by the device in a frequency band, apply all the procedures required for the largest channel bandwidth in section A) to determine the channels and RB configurations that need SAR testing and only measure SAR when the highest maximum output power of a configuration requiring testing in the smaller channel bandwidth is $> \frac{1}{2}\text{ dB}$ higher than the equivalent channel configurations in the largest channel bandwidth configuration or the reported SAR of a configuration for the largest channel bandwidth is $> 1.45\text{ W/kg}$.



1. LTE Band 2 Conducted Power Test Verdict:

BW(MHz)	Modulation	RB Size	RB Offset	Power(dBm) Low Ch./Freq.	Power(dBm) Middle Ch./Freq.	Power(dBm) High Ch./Freq.
Channel				18700	18900	19100
Frequency(MHz)				1860	1880	1900
20	QPSK	1	0	22.64	22.61	22.68
20	QPSK	1	49	22.52	22.49	22.58
20	QPSK	1	99	22.48	22.44	22.45
20	QPSK	50	0	21.79	21.72	21.70
20	QPSK	50	24	21.59	21.61	21.68
20	QPSK	50	49	21.67	21.61	21.63
20	QPSK	100	0	21.54	21.53	21.58
20	16QAM	1	0	21.32	21.21	21.25
20	16QAM	1	49	21.27	21.18	21.23
20	16QAM	1	99	21.17	21.12	21.17
20	16QAM	50	0	20.87	20.78	20.81
20	16QAM	50	24	20.71	20.69	20.70
20	16QAM	50	49	20.64	20.57	20.54
20	16QAM	100	0	20.54	20.61	20.53
Channel				18675	18900	19125
Frequency(MHz)				1857.5	1880	1902.5
15	QPSK	1	0	22.61	22.60	22.66
15	QPSK	1	37	22.47	22.58	22.53
15	QPSK	1	74	22.51	22.46	22.47
15	QPSK	36	0	21.81	21.78	21.84
15	QPSK	36	18	21.65	21.61	21.67
15	QPSK	36	37	21.53	21.55	21.57
15	QPSK	75	0	21.61	21.58	21.60
15	16QAM	1	0	21.40	21.51	21.45
15	16QAM	1	37	21.49	21.55	21.43
15	16QAM	1	74	21.34	21.40	21.39
15	16QAM	36	0	20.67	20.79	20.76
15	16QAM	36	18	20.55	20.47	20.58
15	16QAM	36	37	20.37	20.28	20.31
15	16QAM	75	0	20.79	20.85	20.83



BW(MHz)	Modulation	RB Size	RB Offset	Power(dBm) Low Ch./Freq.	Power(dBm) Middle Ch./Freq.	Power(dBm) High Ch./Freq.
Channel				18650	18900	19150
Frequency(MHz)				1855	1880	1905
10	QPSK	1	0	22.62	22.60	22.58
10	QPSK	1	24	22.47	22.51	22.45
10	QPSK	1	49	22.61	22.54	22.57
10	QPSK	25	0	21.71	21.70	21.74
10	QPSK	25	12	21.54	21.64	21.52
10	QPSK	25	24	21.68	21.65	21.73
10	QPSK	50	0	21.63	21.74	21.71
10	16QAM	1	0	21.71	21.63	21.87
10	16QAM	1	24	21.46	21.37	21.39
10	16QAM	1	49	21.57	21.52	21.45
10	16QAM	25	0	20.67	20.81	20.75
10	16QAM	25	12	20.56	20.66	20.59
10	16QAM	25	24	20.71	20.64	20.75
10	16QAM	50	0	20.69	20.75	20.67
Channel				18625	18900	19175
Frequency(MHz)				1852.5	1880	1907.5
5	QPSK	1	0	22.59	22.64	22.58
5	QPSK	1	12	22.32	22.41	22.49
5	QPSK	1	24	22.52	22.58	22.41
5	QPSK	12	0	21.64	21.66	21.71
5	QPSK	12	6	21.58	21.62	21.57
5	QPSK	12	11	21.54	21.70	21.65
5	QPSK	25	0	21.66	21.72	21.71
5	16QAM	1	0	21.67	21.75	21.64
5	16QAM	1	12	21.64	21.52	21.61
5	16QAM	1	24	21.45	21.59	21.56
5	16QAM	12	0	20.60	20.70	20.76
5	16QAM	12	6	20.69	20.66	20.75
5	16QAM	12	11	20.54	20.57	20.64
5	16QAM	25	0	20.86	20.87	20.91



BW(MHz)	Modulation	RB Size	RB Offset	Power(dBm) Low Ch./Freq.	Power(dBm) Middle Ch./Freq.	Power(dBm) High Ch./Freq.
Channel				18615	18900	19185
Frequency(MHz)				1851.5	1880	1908.5
3	QPSK	1	0	22.59	22.55	22.60
3	QPSK	1	7	22.52	22.47	22.55
3	QPSK	1	14	22.48	22.53	22.57
3	QPSK	8	0	21.64	21.69	21.72
3	QPSK	8	4	21.64	21.54	21.59
3	QPSK	8	7	21.71	21.64	21.67
3	QPSK	15	0	21.61	21.71	21.62
3	16QAM	1	0	21.59	21.64	21.71
3	16QAM	1	7	21.35	21.41	21.38
3	16QAM	1	14	21.24	21.19	21.31
3	16QAM	8	0	20.86	20.84	20.83
3	16QAM	8	4	20.67	20.75	20.71
3	16QAM	8	7	20.64	20.61	20.65
3	16QAM	15	0	20.86	20.81	20.85
Channel				18607	18900	19193
Frequency(MHz)				1850.7	1732.5	1909.3
1.4	QPSK	1	0	22.53	22.62	22.57
1.4	QPSK	1	2	22.47	22.51	22.48
1.4	QPSK	1	5	22.44	22.51	22.52
1.4	QPSK	3	0	21.65	21.67	21.59
1.4	QPSK	3	1	21.68	21.75	21.78
1.4	QPSK	3	2	21.64	21.68	21.75
1.4	QPSK	6	0	21.71	21.59	21.63
1.4	16QAM	1	0	21.61	21.57	21.62
1.4	16QAM	1	2	21.68	21.75	21.73
1.4	16QAM	1	5	21.64	21.71	21.62
1.4	16QAM	3	0	20.57	20.49	20.47
1.4	16QAM	3	1	20.85	20.77	20.82
1.4	16QAM	3	2	20.34	20.49	20.39
1.4	16QAM	6	0	20.67	20.72	20.70



2. LTE Band 4 Conducted Power Test Verdict:

BW(MHz)	Modulation	RB Size	RB Offset	Power(dBm) Low Ch./Freq.	Power(dBm) Middle Ch./Freq.	Power(dBm) High Ch./Freq.
Channel				20050	20175	20300
Frequency(MHz)				1720	1732.5	1745
20	QPSK	1	0	22.27	22.28	22.25
20	QPSK	1	49	22.14	22.15	22.11
20	QPSK	1	99	22.10	22.17	22.09
20	QPSK	50	0	21.50	21.51	21.49
20	QPSK	50	24	21.74	21.62	21.73
20	QPSK	50	49	21.54	21.60	21.51
20	QPSK	100	0	21.50	21.46	21.53
20	16QAM	1	0	21.87	21.79	21.68
20	16QAM	1	49	21.82	21.80	21.75
20	16QAM	1	99	21.67	21.76	21.74
20	16QAM	50	0	20.65	20.71	20.67
20	16QAM	50	24	20.29	20.43	20.45
20	16QAM	50	49	20.50	20.57	20.53
20	16QAM	100	0	20.69	20.57	20.64
Channel				20025	20175	20325
Frequency(MHz)				1717.5	1732.5	1747.5
15	QPSK	1	0	22.25	22.20	22.19
15	QPSK	1	37	22.23	22.21	22.24
15	QPSK	1	74	22.10	22.17	22.13
15	QPSK	36	0	21.52	21.54	21.47
15	QPSK	36	18	21.57	21.55	21.51
15	QPSK	36	37	21.44	21.42	21.42
15	QPSK	75	0	21.61	21.55	21.52
15	16QAM	1	0	21.40	21.35	21.31
15	16QAM	1	37	21.34	21.35	21.43
15	16QAM	1	74	21.54	21.40	21.41
15	16QAM	36	0	20.67	20.75	20.78
15	16QAM	36	18	20.59	20.67	20.60
15	16QAM	36	37	20.61	20.71	20.66
15	16QAM	75	0	20.74	20.79	20.71



BW(MHz)	Modulation	RB Size	RB Offset	Power(dBm) Low Ch./Freq.	Power(dBm) Middle Ch./Freq.	Power(dBm) High Ch./Freq.
Channel				20000	20175	20350
Frequency(MHz)				1715	1732.5	1750
10	QPSK	1	0	22.22	22.27	22.25
10	QPSK	1	24	22.15	22.12	22.17
10	QPSK	1	49	22.12	22.19	22.22
10	QPSK	25	0	21.44	21.46	21.51
10	QPSK	25	12	21.42	21.39	21.30
10	QPSK	25	24	21.37	21.40	21.35
10	QPSK	50	0	21.45	21.42	21.48
10	16QAM	1	0	21.42	21.45	21.41
10	16QAM	1	24	21.21	21.32	21.30
10	16QAM	1	49	21.38	21.45	21.46
10	16QAM	25	0	20.75	20.73	20.80
10	16QAM	25	12	20.68	20.70	20.72
10	16QAM	25	24	20.62	20.65	20.54
10	16QAM	50	0	20.82	20.76	20.79
Channel				19975	20175	20375
Frequency(MHz)				1712.5	1732.5	1752.5
5	QPSK	1	0	22.17	22.20	22.22
5	QPSK	1	12	22.13	22.11	22.18
5	QPSK	1	24	22.09	22.17	22.01
5	QPSK	12	0	21.62	21.57	21.64
5	QPSK	12	6	21.48	21.56	21.51
5	QPSK	12	11	21.56	21.54	21.60
5	QPSK	25	0	21.49	21.46	21.52
5	16QAM	1	0	21.41	21.37	21.33
5	16QAM	1	12	21.50	21.46	21.39
5	16QAM	1	24	21.27	21.32	21.38
5	16QAM	12	0	20.46	20.53	20.44
5	16QAM	12	6	20.49	20.45	20.57
5	16QAM	12	11	20.47	20.50	20.43
5	16QAM	25	0	20.68	20.75	20.71



BW(MHz)	Modulation	RB Size	RB Offset	Power(dBm) Low Ch./Freq.	Power(dBm) Middle Ch./Freq.	Power(dBm) High Ch./Freq.
Channel				19965	20175	20385
Frequency(MHz)				1711.5	1732.5	1753.5
3	QPSK	1	0	22.16	22.24	22.18
3	QPSK	1	7	22.15	22.10	22.13
3	QPSK	1	14	22.12	22.15	22.07
3	QPSK	8	0	21.57	21.61	21.56
3	QPSK	8	4	21.60	21.55	21.48
3	QPSK	8	7	21.59	21.52	21.51
3	QPSK	15	0	21.37	21.44	21.41
3	16QAM	1	0	21.51	21.55	21.49
3	16QAM	1	7	21.57	21.45	21.53
3	16QAM	1	14	21.52	21.50	21.56
3	16QAM	8	0	20.53	20.60	20.62
3	16QAM	8	4	20.64	20.68	20.71
3	16QAM	8	7	20.53	20.52	20.55
3	16QAM	15	0	20.72	20.66	20.78
Channel				19957	20175	20393
Frequency(MHz)				1710.7	1732.5	1754.3
1.4	QPSK	1	0	22.25	22.21	22.18
1.4	QPSK	1	2	22.21	22.18	22.19
1.4	QPSK	1	5	22.17	22.09	22.13
1.4	QPSK	3	0	21.61	21.58	21.52
1.4	QPSK	3	1	21.57	21.53	21.48
1.4	QPSK	3	2	21.46	21.57	21.51
1.4	QPSK	6	0	21.57	21.46	21.53
1.4	16QAM	1	0	21.32	21.37	21.39
1.4	16QAM	1	2	21.43	21.34	21.41
1.4	16QAM	1	5	21.31	21.42	21.34
1.4	16QAM	3	0	20.75	20.74	20.75
1.4	16QAM	3	1	20.57	20.63	20.61
1.4	16QAM	3	2	20.50	20.51	20.57
1.4	16QAM	6	0	20.69	20.72	20.63



3. LTE Band 7 Conducted Power Test Verdict:

BW(MHz)	Modulation	RB Size	RB Offset	Power(dBm) Low Ch./Freq.	Power(dBm) Middle Ch./Freq.	Power(dBm) High Ch./Freq.
Channel				20850	21100	21350
Frequency(MHz)				2510	2535	2560
20	QPSK	1	0	23.22	23.35	23.27
20	QPSK	1	49	23.18	23.15	23.23
20	QPSK	1	99	23.15	23.22	23.25
20	QPSK	50	0	22.62	22.74	22.67
20	QPSK	50	24	22.77	22.75	22.71
20	QPSK	50	49	22.64	22.62	22.65
20	QPSK	100	0	22.62	22.55	22.60
20	16QAM	1	0	22.30	22.31	22.35
20	16QAM	1	49	22.34	22.25	22.33
20	16QAM	1	99	22.28	22.30	22.24
20	16QAM	50	0	21.67	21.75	21.72
20	16QAM	50	24	21.59	21.67	21.70
20	16QAM	50	49	21.61	21.51	21.56
20	16QAM	100	0	21.70	21.65	21.71
Channel				20825	21100	21375
Frequency(MHz)				2507.5	2535	2562.5
15	QPSK	1	0	23.24	23.31	23.34
15	QPSK	1	37	23.32	23.29	23.28
15	QPSK	1	74	23.22	23.30	23.25
15	QPSK	36	0	22.79	22.87	22.73
15	QPSK	36	18	22.67	22.75	22.64
15	QPSK	36	37	22.64	22.72	22.75
15	QPSK	75	0	22.75	22.81	22.77
15	16QAM	1	0	22.28	22.31	22.35
15	16QAM	1	37	22.34	22.45	22.43
15	16QAM	1	74	22.54	22.60	22.57
15	16QAM	36	0	21.67	21.79	21.76
15	16QAM	36	18	21.75	21.67	21.78
15	16QAM	36	37	21.67	21.58	21.61
15	16QAM	75	0	21.79	21.85	21.83



BW(MHz)	Modulation	RB Size	RB Offset	Power(dBm) Low Ch./Freq.	Power(dBm) Middle Ch./Freq.	Power(dBm) High Ch./Freq.
Channel				20800	21100	21400
Frequency(MHz)				2505	2535	2565
10	QPSK	1	0	23.25	23.30	23.25
10	QPSK	1	24	23.27	23.31	23.24
10	QPSK	1	49	23.31	23.24	23.27
10	QPSK	25	0	22.71	22.70	22.74
10	QPSK	25	12	22.58	22.64	22.54
10	QPSK	25	24	22.68	22.65	22.73
10	QPSK	50	0	22.63	22.58	22.64
10	16QAM	1	0	22.71	22.63	22.77
10	16QAM	1	24	22.46	22.57	22.59
10	16QAM	1	49	22.57	22.42	22.55
10	16QAM	25	0	21.67	21.71	21.75
10	16QAM	25	12	21.56	21.66	21.59
10	16QAM	25	24	21.71	21.64	21.75
10	16QAM	50	0	21.89	21.75	21.77
Channel				20775	21100	21425
Frequency(MHz)				2502.5	2535	2567.5
5	QPSK	1	0	23.25	23.30	23.28
5	QPSK	1	12	23.32	23.31	23.29
5	QPSK	1	24	23.22	23.29	23.31
5	QPSK	12	0	22.64	22.76	22.75
5	QPSK	12	6	22.58	22.65	22.57
5	QPSK	12	11	22.64	22.70	22.65
5	QPSK	25	0	22.66	22.72	22.71
5	16QAM	1	0	22.67	22.75	22.64
5	16QAM	1	12	22.64	22.59	22.61
5	16QAM	1	24	22.75	22.79	22.68
5	16QAM	12	0	21.63	21.70	21.76
5	16QAM	12	6	21.69	21.66	21.75
5	16QAM	12	11	21.54	21.57	21.64
5	16QAM	25	0	21.86	21.71	21.81



4. LTE Band 17 Conducted Power Test Verdict:

BW(MHz)	Modulation	RB Size	RB Offset	Power(dBm) Low Ch./Freq.	Power(dBm) Middle Ch./Freq.	Power(dBm) High Ch./Freq.
Channel				23780	23790	23800
Frequency(MHz)				709	710	711
10	QPSK	1	0	23.18	23.24	23.23
10	QPSK	1	24	23.19	23.16	23.09
10	QPSK	1	49	23.12	23.10	23.14
10	QPSK	25	0	22.72	22.71	22.76
10	QPSK	25	12	22.67	22.36	22.64
10	QPSK	25	24	22.61	22.65	22.71
10	QPSK	50	0	22.69	22.66	22.67
10	16QAM	1	0	22.14	22.14	22.27
10	16QAM	1	24	22.66	22.11	22.53
10	16QAM	1	49	22.30	22.31	22.42
10	16QAM	25	0	21.41	21.46	21.45
10	16QAM	25	12	21.64	21.75	21.41
10	16QAM	25	24	21.51	21.74	21.46
10	16QAM	50	0	21.53	21.46	21.51
Channel				23755	23790	23825
Frequency(MHz)				706.5	710	713.5
5	QPSK	1	0	23.22	23.14	23.20
5	QPSK	1	12	23.09	23.13	23.16
5	QPSK	1	24	23.14	23.10	23.15
5	QPSK	12	0	22.60	22.63	22.67
5	QPSK	12	6	22.56	22.52	22.57
5	QPSK	12	11	22.50	22.54	22.59
5	QPSK	25	0	22.44	22.49	22.52
5	16QAM	1	0	22.24	22.29	22.19
5	16QAM	1	12	22.25	22.18	22.26
5	16QAM	1	24	22.53	22.47	22.45
5	16QAM	12	0	21.40	21.35	21.47
5	16QAM	12	6	21.42	21.45	21.39
5	16QAM	12	11	21.51	21.54	21.48
5	16QAM	25	0	21.37	21.34	21.42

WLAN 2.4GHz Band Conducted Power

For the 802.11b/g SAR tests, a communication link is set up with the test mode software for WiFi mode test. The Absolute Radio Frequency Channel Number (ARFCN) is allocated to 1, 6 and 11 respectively in the case of 2450 MHz. During the test, at each test frequency channel, the EUT is operated at the RF continuous emission mode. Each channel should be tested at the lowest data rate.

802.11b/g operating modes are tested independently according to the service requirements in each frequency band. 802.11b/g modes are tested on channel 1, 6, 11; however, if output power reduction is necessary for channels 1 and/or 11 to meet restricted band requirements the highest output channel closest to each of these channels must be tested instead.

SAR is not required for 802.11g/n channels when the maximum average output power is less than 0.25dB higher than that measured on the corresponding 802.11b channels.

Channel/Freq.(MHz)	Peak Power (dBm) for Data Rates (Mbps)		
	802.11b	802.11g	802.11n(HT20)
1(2412)	19.34	20.22	20.45
6(2437)	19.15	21.24	21.52
11(2462)	19.11	20.15	20.30
Channel	802.11n(HT40)		
3(2422)	16.07		
6(2437)	18.05		
9(2452)	16.14		

Channel/Freq.(MHz)	Average Power (dBm) for Data Rates (Mbps)		
	802.11b	802.11g	802.11n(HT20)
1(2412)	16.36	16.25	15.87
6(2437)	16.29	16.27	16.13
11(2462)	16.22	16.21	15.83
Channel	802.11n(HT40)		
3(2422)	11.15		
6(2437)	12.96		
9(2452)	11.21		

Note:

1. Per KDB248227 D01 v02r02, choose the highest output power channel to test SAR and determine further SAR exclusion
2. For each frequency band, testing at higher data rates and higher order modulations is not required when the maximum average output power for each of these configurations is less than 1/4dB higher than those measured at lowest data rate
3. Per KDB248227 D01 v02r02, 802.11g /11n-HT20/11n-HT40 is not required. . When the highest reported SAR for DSSS is adjusted by the ratio of OFDM to DSSS specified maximum output power and the adjusted SAR is $\leq 1.2\text{W/Kg}$. Thus the SAR can be excluded.



Bluetooth Peak Conducted Power

Channel	Frequency (MHz)	BT3.0 Output Power(dBm)		
		GFSK	π /4-DQPSK	8-DPSK
CH 0	2402	7.43	6.00	6.17
CH 39	2441	7.65	6.24	6.30
CH 78	2480	7.36	6.02	6.19
Channel	Frequency (MHz)	BT4.0 Output Power(dBm)		
		GFSK		
CH 0	2402	-0.60		
CH 20	2442	-0.39		
CH 39	2480	-0.43		

Bluetooth Average Conducted Power

Channel	Frequency (MHz)	BT3.0 Output Power(dBm)		
		GFSK	π /4-DQPSK	8-DPSK
CH 0	2402	5.89	4.38	4.41
CH 39	2441	5.93	4.51	4.48
CH 78	2480	5.82	4.40	4.44
Channel	Frequency (MHz)	BT4.0 Output Power(dBm)		
		GFSK		
CH 0	2402	-1.72		
CH 20	2442	-1.57		
CH 39	2480	-1.63		

Note:

- Per KDB 447498 D01v06, the 1-g and 10-g SAR test exclusion thresholds for 100MHz to 6GHz at test separation distances $\leq 50\text{mm}$ are determined by: $[(\text{max. power of channel, including tune-up tolerance, mW}) / (\text{min. test separation distance, mm})] \cdot [\sqrt{f} \text{ (GHz)}] \leq 3.0$ for 1-g SAR and ≤ 7.5 for 10-g extremity SAR
 - f(GHz) is the RF channel transmit frequency in GHz
 - Power and distance are round to the nearest mW and mm before calculation
 - The result is rounded to one decimal place for comparison
 - If the test separation distance(antenna-user) is $< 5\text{mm}$, 5mm is used for excluded SAR calculation

Bluetooth Max Power (dBm)	mW	Test Distance (mm)	Frequency(Ghz)	Exclusion Thresholds
8.0	6.310	5	2.4	1.955

Per KDB 447498 D01v06 exclusion thresholds is $1.955 < 3$, RF exposure evaluation is not required.
 BT estimated SAR value=Exclusion Thresholds/7.5= $1.955/7.5=0.261\text{W/Kg}$

Bluetooth Max Power (dBm)	mW	Test Distance (mm)	Frequency(Ghz)	Exclusion Thresholds
8.0	6.310	10	2.4	0.977

Per KDB 447498 D01v06 exclusion thresholds is $0.977 < 3$, RF exposure evaluation is not required.
 BT estimated SAR value=Exclusion Thresholds/7.5= $0.977/7.5=0.130\text{W/Kg}$

The estimated SAR value is used for simultaneous transmission analysis.

General Note:

1. Per KDB 447498 D01v06, the reported SAR is the measured SAR value adjusted for maximum tune-up tolerance.
2. Per KDB447498 D01v06, testing of other required channels within the operating mode of a frequency band is not required when the reported 1-g or 10-g SAR for the mid-band or highest output power channel is: ≤ 0.8 W/kg or 2.0 W/kg, for 1-g or 10-g respectively, when the transmission band is ≤ 100 MHz. When the maximum output power variation across the required test channels is $> \frac{1}{2}$ dB, instead of the middle channel, the highest output power channel must be used.
3. Per KDB941225 D06 v02r01, the DUT Dimension is bigger than 9 cm x 5 cm, so 10mm is chosen as the test separation distance for Hotspot mode. When the antenna-to-edge distance is greater than 2.5cm, such position does not need to be tested. As the manufacture required, the separation distance use 5mm for Hotspot mode.
4. Per KDB 865664 D01v01r04,for each frequency band,repeated SAR measurement is required only when the measured SAR is ≥ 0.8 W/Kg; if the deviation among the repeated measurement is $\leq 20\%$,and the measured SAR < 1.45 W/Kg,only one repeated measurement is required.
5. Per KDB865664 D02 v01r02, SAR plot is only required for the highest measured SAR in each exposure configuration, wireless mode and frequency band combination; Plots are also required when the measured SAR is > 1.5 W/kg, or > 7.0 W/kg for occupational exposure. The published RF exposure KDB procedures may require additional plots; for example, to support SAR to peak location separation ratio test exclusion and/or volume scan post-processing(Refer to appendix D for details).
6. Per KDB941225 D01 v03r01, when multiple slots can be used, the GPRS/EDGE slot configuration with the highest frame–averaged output power was selected for SAR testing.
7. Per KDB941225 D01 v03r01, when the maximum output power and tune-up tolerance specified for production units in a secondary mode is $\leq \frac{1}{4}$ dB higher than the primary mode or when the highest reported SAR of the primary mode is scaled by the ratio of specified maximum output power and tune-up tolerance of secondary to primary mode and the adjusted SAR is ≤ 1.2 W/kg, SAR measurement is not required for the secondary mode.
8. Per KDB248227 D01 v02r02, 802.11g /11n-HT20/11n-HT40 is not required. When the highest reported SAR for DSSS is adjusted by the ratio of OFDM to DSSS specified maximum output power and the adjusted SAR is ≤ 1.2 W/Kg. Thus the SAR can be excluded.



9.3. Scaling Factor calculation

Operation Mode	Channel	Output Power(dBm)	Tune up Power in tolerance(dBm)	Scaling Factor
GSM 850	128	32.56	32.5 ± 0.5	1.107
	190	32.55	32.5 ± 0.5	1.109
	251	32.57	32.5 ± 0.5	1.104
GPRS 850(3Tx)	128	27.88	27.5 ± 0.5	1.028
	190	27.86	27.5 ± 0.5	1.033
	251	27.91	27.5 ± 0.5	1.021
GSM1900	512	28.96	29.0 ± 0.5	1.132
	661	29.00	29.0 ± 0.5	1.122
	810	29.18	29.0 ± 0.5	1.076
GPRS1900(3Tx)	512	25.82	25.5 ± 0.5	1.042
	661	25.81	25.5 ± 0.5	1.045
	810	25.84	25.5 ± 0.5	1.038
WCDMA850	4132	22.95	22.5 ± 0.5	1.012
	4183	22.76	22.5 ± 0.5	1.057
	4233	22.89	22.5 ± 0.5	1.026
WCDMA1700	1312	22.50	22.5 ± 0.5	1.122
	1413	22.45	22.5 ± 0.5	1.135
	1513	22.41	22.5 ± 0.5	1.146
WCDMA1900	9262	22.66	22.5 ± 0.5	1.081
	9400	22.50	22.5 ± 0.5	1.122
	9538	22.73	22.5 ± 0.5	1.064
LTE B2 20MHz 1RB#0	18700	22.64	22.5 ± 0.5	1.086
	18900	22.61	22.5 ± 0.5	1.094
	19100	22.68	22.5 ± 0.5	1.076
LTE B2 20MHz 50RB#0	18700	21.79	21.5 ± 0.5	1.050
	18900	21.72	21.5 ± 0.5	1.067
	19100	21.70	21.5 ± 0.5	1.072
LTE B2 20MHz 100RB#0	18700	21.54	21.5 ± 0.5	1.112
	18900	21.53	21.5 ± 0.5	1.114
	19100	21.58	21.5 ± 0.5	1.102
LTE B4 20MHz 1RB#0	20050	22.27	22.0 ± 0.5	1.054
	20175	22.28	22.0 ± 0.5	1.052
	20300	22.25	22.0 ± 0.5	1.059



LTE B4 20MHz 50RB#0	20050	21.74	21.5 ± 0.5	1.062
	20175	21.62	21.5 ± 0.5	1.091
	20300	21.73	21.5 ± 0.5	1.064
LTE B4 20MHz 100RB#0	20050	21.50	21.5 ± 0.5	1.122
	20175	21.46	21.5 ± 0.5	1.132
	20300	21.53	21.5 ± 0.5	1.114
LTE B7 20MHz 1RB#0	20850	23.22	23.0 ± 0.5	1.067
	21100	23.35	23.0 ± 0.5	1.035
	21350	23.27	23.0 ± 0.5	1.054
LTE B7 20MHz 50RB#24	20850	22.77	22.5 ± 0.5	1.054
	21100	22.75	22.5 ± 0.5	1.059
	21350	22.71	22.5 ± 0.5	1.069
LTE B7 20MHz 100RB#0	20850	22.62	22.5 ± 0.5	1.091
	21100	22.55	22.5 ± 0.5	1.109
	21350	22.60	22.5 ± 0.5	1.096
LTE B17 10MHz 1RB#0	23780	23.18	23.0 ± 0.5	1.076
	23790	23.24	23.0 ± 0.5	1.062
	23800	23.23	23.0 ± 0.5	1.064
LTE B17 10MHz 25RB#0	23780	22.72	22.5 ± 0.5	1.067
	23790	22.71	22.5 ± 0.5	1.069
	23800	22.76	22.5 ± 0.5	1.057
LTE B17 10MHz 50RB#0	23780	22.69	22.5 ± 0.5	1.074
	23790	22.66	22.5 ± 0.5	1.081
	23800	22.67	22.5 ± 0.5	1.079
WIFI 802.11b	1	19.34	19.0 ± 0.5	1.038
	6	19.15	19.0 ± 0.5	1.084
	11	19.11	19.0 ± 0.5	1.094
BT	39	7.65	7.5 ± 0.5	1.084

Note: for LTE power tolerance, only QPSK modulation mode was provide here.



Simultaneous SAR

No.	Transmitter Combinations	Scenario Supported or not	Supported for Mobile Hotspot or not
1	GSM(Voice)+GSM(Data)	No	No
2	WCDMA(Voice)+WCDMA(Data)	Yes	No
3	GSM(Voice)+ WCDMA(Data)	No	No
4	WCDMA(Voice)+GSM(Data)	No	No
5	GSM(Voice)+ WCDMA(Voice)	No	No
6	GSM(Voice)+Wifi	Yes	No
7	WCDMA(Voice) +Wifi	Yes	No
8	GSM(Voice)+ BT	Yes	No
9	WCDMA(Voice) + BT	Yes	No
10	GSM(Data)+wifi	Yes	Yes
11	WCDMA(Data) +wifi	Yes	Yes
12	LTE(Data)+GSM(Voice/Data)	No	No
13	LTE(Data)+WCDMA(Voice/Data)	No	No
14	LTE(Data)+WIFI	Yes	Yes

10 TEST RESULTS

10.1 Summary of SAR Measurement Results

Table 7: SAR Values of GSM 850MHz Band

Temperature: 23.0~23.5°C, humidity: 62~64%.						
Test Positions		Channel /Frequency (MHz)	SAR(W/Kg), 1.6 (1g average)		Plot No.	
			SAR(W/Kg), 1g	Scaled SAR(W/Kg),1g		
Right Side of Head	Cheek	251/848.8	0.045	0.050	--	
	Tilt 15 degrees	251/848.8	0.035	0.039	--	
Left Side of Head	Cheek	251/848.8	0.052	0.057	1	
	Tilt 15 degrees	251/848.8	0.037	0.041	--	
Body-worn (10mm Separation)	GSM	Face Upward	251/848.8	0.054	0.060	
		Back Upward	251/848.8	0.078	0.086	2
Hotspot (10mm Separation)	GPRS (3Tx)	Face Upward	251/848.8	0.070	0.071	
		Back Upward	251/848.8	0.099	0.101	3
		Edge B	251/848.8	0.044	0.045	--
		Edge C	251/848.8	0.029	0.030	--
		Edge D	251/848.8	0.058	0.059	--

Table 8: SAR Values of GSM1900 MHz Band

Temperature: 23.0~23.5°C, humidity: 62~64%.						
Test Positions		Channel /Frequency (MHz)	SAR(W/Kg), 1.6 (1g average)		Plot No.	
			SAR(W/Kg), 1g	Scaled SAR(W/Kg),1g		
Right Side of Head	Cheek	810/1909.8	0.228	0.245	4	
	Tilt 15 degrees	810/1909.8	0.056	0.060	--	
Left Side of Head	Cheek	810/1909.8	0.183	0.197	--	
	Tilt 15 degrees	810/1909.8	0.047	0.051	--	
Body-worn (10mm Separation)	GSM	Face Upward	810/1909.8	0.225	0.242	
		Back Upward	810/1909.8	0.237	0.255	5
Hotspot (10mm Separation)	GPRS (3Tx)	Face Upward	810/1909.8	0.211	0.219	
		Back Upward	810/1909.8	0.171	0.177	--
		Edge B	810/1909.8	0.095	0.099	--
		Edge C	810/1909.8	0.390	0.405	6
		Edge D	810/1909.8	0.055	0.057	--



Table 9: SAR Values of WCDMA1900

Temperature: 23.0~23.5°C, humidity: 62~64%.

Test Positions		Channel /Frequency (MHz)	SAR(W/Kg), 1.6 (1g average)		Plot No.
			SAR(W/Kg), 1g	Scaled SAR(W/Kg),1g	
Right Side of Head	Cheek	9538/1907.6	0.156	0.166	--
	Tilt 15 degrees	9538/1907.6	0.084	0.089	--
Left Side of Head	Cheek	9538/1907.6	0.163	0.173	7
	Tilt 15 degrees	9538/1907.6	0.085	0.090	--
Body-worn (10mm Separation)	Face Upward	9538/1907.6	0.402	0.428	8
	Back Upward	9538/1907.6	0.389	0.414	--
Hotspot (10mm Separation)	Face Upward	9538/1907.6	0.402	0.428	--
	Back Upward	9538/1907.6	0.389	0.414	--
	Edge B	9538/1907.6	0.189	0.201	--
	Edge C	9262/1852.4	0.742	0.802	--
		9400/1880.0	0.714	0.801	--
		9538/1907.6	0.778	0.828	9
	Edge D	9538/1907.6	0.773	0.822	--
Edge D	9538/1907.6	0.117	0.124	--	

Table 10: SAR Values of WCDMA1700

Temperature: 23.0~23.5°C, humidity: 62~64%.

Test Positions		Channel /Frequency (MHz)	SAR(W/Kg), 1.6 (1g average)		Plot No.
			SAR(W/Kg), 1g	Scaled SAR(W/Kg),1g	
Right Side of Head	Cheek	1312/1712.4	0.171	0.192	--
	Tilt 15 degrees	1312/1712.4	0.140	0.157	--
Left Side of Head	Cheek	1312/1712.4	0.214	0.240	10
	Tilt 15 degrees	1312/1712.4	0.167	0.187	--
Body-worn (10mm Separation)	Face Upward	1312/1712.4	0.556	0.624	--
	Back Upward	1312/1712.4	0.638	0.716	11
Hotspot (10mm Separation)	Face Upward	1312/1712.4	0.556	0.624	--
	Back Upward	1312/1712.4	0.638	0.716	11
	Edge B	1312/1712.4	0.218	0.245	--
	Edge C	1312/1712.4	0.543	0.609	--
	Edge D	1312/1712.4	0.095	0.107	--

Table 11: SAR Values of WCDMA850

Temperature: 23.0~23.5°C, humidity: 62~64%.

Test Positions		Channel /Frequency (MHz)	SAR(W/Kg), 1.6 (1g average)		Plot No.
			SAR(W/Kg), 1g	Scaled SAR(W/Kg),1g	
Right Side of Head	Cheek	4132/826.4	0.048	0.049	--
	Tilt 15 degrees	4132/826.4	0.031	0.031	--
Left Side of Head	Cheek	4132/826.4	0.053	0.054	12
	Tilt 15 degrees	4132/826.4	0.039	0.039	--



Body-worn (10mm Separation)	Face Upward	4132/826.4	0.091	0.092	--
	Back Upward	4132/826.4	0.121	0.122	13
Hotspot (10mm Separation)	Face Upward	4132/826.4	0.091	0.092	--
	Back Upward	4132/826.4	0.121	0.122	13
	Edge B	4132/826.4	0.050	0.051	--
	Edge C	4132/826.4	0.013	0.013	--
	Edge D	4132/826.4	0.085	0.086	--

Table 12: SAR Values of LTE Band 2 , 20MHz, QPSK

Temperature: 23.0~23.5°C, humidity: 62~64%.					
Test Positions	Channel /Frequency (MHz)	SAR(W/Kg), 1.6 (1g average)		Plot No.	
		SAR(W/Kg), 1g	Scaled SAR(W/Kg), 1g		
1RB #0					
Right Side of Head	Cheek	19100/1900	0.154	0.166	14
	Tilt 15 degrees	19100/1900	0.079	0.085	--
Left Side of Head	Cheek	19100/1900	0.148	0.159	--
	Tilt 15 degrees	19100/1900	0.075	0.081	--
Body (10mm Separation) Body-worn	Face Upward	19100/1900	0.274	0.295	--
	Back Upward	19100/1900	0.407	0.438	15
Body (10mm Separation) Hotspot	Face Upward	19100/1900	0.274	0.295	--
	Back Upward	19100/1900	0.407	0.438	--
	Edge B	19100/1900	0.191	0.206	--
	Edge C	19100/1900	0.618	0.665	16
	Edge D	19100/1900	0.153	0.165	--
50%RB #0					
Right Side of Head	Cheek	18700/1860	0.147	0.154	--
	Tilt 15 degrees	18700/1860	0.073	0.077	--
Left Side of Head	Cheek	18700/1860	0.142	0.149	--
	Tilt 15 degrees	18700/1860	0.072	0.076	--
Body (10mm Separation) Body-worn	Face Upward	18700/1860	0.258	0.271	--
	Back Upward	18700/1860	0.400	0.420	--
Body (10mm Separation) Hotspot	Face Upward	18700/1860	0.258	0.271	--
	Back Upward	18700/1860	0.400	0.420	--
	Edge B	18700/1860	0.182	0.191	--
	Edge C	18700/1860	0.589	0.618	--
	Edge D	18700/1860	0.136	0.143	--

Table 13: SAR Values of LTE Band 4 , 20MHz, QPSK

Temperature: 23.0~23.5°C, humidity: 62~64%.					
Test Positions	Channel /Frequency (MHz)	SAR(W/Kg), 1.6 (1g average)		Plot No.	
		SAR(W/Kg), 1g	Scaled SAR(W/Kg), 1g		
1RB #0					
Right Side of Head	Cheek	20175/1732.5	0.152	0.160	--
	Tilt 15 degrees	20175/1732.5	0.116	0.122	--
Left Side of Head	Cheek	20175/1732.5	0.176	0.185	17
	Tilt 15 degrees	20175/1732.5	0.121	0.127	--



Body (10mm Separation) Body-worn	Face Upward	20175/1732.5	0.512	0.539	--
	Back Upward	20175/1732.5	0.633	0.666	18
Body (10mm Separation) Hotspot	Face Upward	20175/1732.5	0.512	0.539	--
	Back Upward	20175/1732.5	0.633	0.666	18
	Edge B	20175/1732.5	0.205	0.216	--
	Edge C	20175/1732.5	0.481	0.506	--
	Edge D	20175/1732.5	0.058	0.061	--
50%RB #24					
Right Side of Head	Cheek	20050/1720	0.145	0.154	--
	Tilt 15 degrees	20050/1720	0.103	0.109	--
Left Side of Head	Cheek	20050/1720	0.158	0.168	--
	Tilt 15 degrees	20050/1720	0.116	0.123	--
Body (10mm Separation) Body-worn	Face Upward	20050/1720	0.488	0.518	--
	Back Upward	20050/1720	0.617	0.655	--
Body (10mm Separation) Hotspot	Face Upward	20050/1720	0.488	0.518	--
	Back Upward	20050/1720	0.617	0.655	--
	Edge B	20050/1720	0.201	0.213	--
	Edge C	20050/1720	0.476	0.506	--
	Edge D	20050/1720	0.057	0.061	--

Table 14: SAR Values of LTE Band 7,20MHz, QPSK

Temperature: 23.0~23.5°C, humidity: 62~64%.					
Test Positions	Channel /Frequency (MHz)	SAR(W/Kg), 1.6 (1g average)		Plot No.	
		SAR(W/Kg), 1g	Scaled SAR(W/Kg), 1g		
1RB #0					
Right Side of Head	Cheek	21100/2535	0.072	0.075	19
	Tilt 15 degrees	21100/2535	0.046	0.048	--
Left Side of Head	Cheek	21100/2535	0.069	0.071	--
	Tilt 15 degrees	21100/2535	0.043	0.045	--
Body (10mm Separation) Body-worn	Face Upward	21100/2535	0.380	0.393	--
	Back Upward	20850/2510	0.781	0.833	--
		21100/2535	0.822	0.851	20
		21100/2535 Repeat	0.815	0.844	--
		21350/2560	0.790	0.833	--
Body (10mm Separation) Hotspot	Face Upward	21100/2535	0.380	0.393	--
	Back Upward	20850/2510	0.781	0.833	--
		21100/2535	0.822	0.851	--
		21100/2535 Repeat	0.815	0.844	--
		21350/2560	0.790	0.833	--
	Edge B	21100/2535	0.085	0.088	--
	Edge C	20850/2510	0.958	1.022	--
		21100/2535	1.080	1.118	21
		21100/2535 Repeat	1.013	1.048	--



		21350/2560	0.982	1.035	--
	Edge D	21100/2535	0.016	0.017	--
50%RB #24					
Right Side of Head	Cheek	20850/2510	0.065	0.071	--
	Tilt 15 degrees	20850/2510	0.042	0.046	--
Left Side of Head	Cheek	20850/2510	0.062	0.068	--
	Tilt 15 degrees	20850/2510	0.040	0.044	--
Body (10mm Separation) Body-worn	Face Upward	20850/2510	0.345	0.376	--
	Back Upward	20850/2510	0.708	0.772	--
Body (10mm Separation) Hotspot	Face Upward	20850/2510	0.345	0.376	--
	Back Upward	20850/2510	0.708	0.772	--
	Edge B	20850/2510	0.083	0.091	--
	Edge C	20850/2510	0.768	0.838	--
	Edge D	20850/2510	0.014	0.015	--

Table 15: SAR Values of LTE Band 17,10MHz, QPSK

Temperature: 23.0~23.5°C, humidity: 62~64%.					
Test Positions	Channel /Frequency (MHz)	SAR(W/Kg), 1.6 (1g average)		Plot No.	
		SAR(W/Kg), 1g	Scaled SAR(W/Kg), 1g		
1RB #0					
Right Side of Head	Cheek	23790/710	0.074	0.079	22
	Tilt 15 degrees	23790/710	0.052	0.055	--
Left Side of Head	Cheek	23790/710	0.068	0.072	--
	Tilt 15 degrees	23790/710	0.051	0.054	--
Body (10mm Separation) Body-worn	Face Upward	23790/710	0.113	0.120	--
	Back Upward	23790/710	0.142	0.151	23
Body (10mm Separation) Hotspot	Face Upward	23790/710	0.113	0.120	--
	Back Upward	23790/710	0.142	0.151	23
	Edge B	23790/710	0.037	0.039	--
	Edge C	23790/710	0.023	0.024	--
	Edge D	23790/710	0.080	0.085	--
50%RB #0					
Right Side of Head	Cheek	23800/711	0.069	0.073	--
	Tilt 15 degrees	23800/711	0.050	0.053	--
Left Side of Head	Cheek	23800/711	0.065	0.069	--
	Tilt 15 degrees	23800/711	0.048	0.051	--
Body (10mm Separation) Body-worn	Face Upward	23800/711	0.106	0.112	--
	Back Upward	23800/711	0.135	0.143	--
Body (10mm Separation) Hotspot	Face Upward	23800/711	0.106	0.112	--
	Back Upward	23800/711	0.135	0.143	--
	Edge B	23800/711	0.036	0.038	--
	Edge C	23800/711	0.023	0.024	--
	Edge D	23800/711	0.075	0.079	--

Table 16: SAR Values of Wi-Fi 802.11b

Test Positions		Channel /Frequency (MHz)	SAR(W/Kg), 1.6 (1g average)		Plot No.
			SAR(W/Kg)1g Peak	Scaled SAR(W/Kg),1g	
Right Side of Head	Cheek	1/2412	0.363	0.377	--
	Tilt 15 degrees	1/2412	0.479	0.497	24
Left Side of Head	Cheek	1/2412	0.360	0.374	--
	Tilt 15 degrees	1/2412	0.462	0.480	--
Body-worn (10mm Separation)	Face Upward	1/2412	0.076	0.079	--
	Back Upward	1/2412	0.099	0.103	25
Hotspot (10mm Separation)	Face Upward	1/2412	0.076	0.079	--
	Back Upward	1/2412	0.099	0.103	25
	Edge A	1/2412	0.093	0.097	--
	Edge D	1/2412	0.036	0.037	--

Note: When the 1-g SAR for the mid-band channel or the channel with the Highest output power satisfy the following conditions, testing of the other channels in the band is not required.(Per KDB 447498 D01 General RF Exposure Guidance v06)

- ≤ 0.8 W/kg, when the transmission band is ≤ 100 MHz
- ≤ 0.6 W/kg, when the transmission band is between 100 MHz and 200 MHz
- ≤ 0.4 W/kg, when the transmission band is ≥ 200 MHz

Per KDB248227 D01 v02r02, 802.11g /11n-HT20/11n-HT40 is not required. . When the highest reported SAR for DSSS is adjusted by the ratio of OFDM to DSSS specified maximum output power and the adjusted SAR is ≤ 1.2 W/Kg. Thus the SAR can be excluded.

Max. DSSS (802.11b) Power(W)	Report SAR Value(W/Kg)	Max. OFDM (802.11n-20) Power(W)	Adjusted SAR Value(W/Kg)
0.0859	0.497	0.1419	0.821

Note: 19.34dBm=0.0859W, 21.52dBm=0.1419W.

10.2 Conclusion

Localized Specific Absorption Rate (SAR) of this portable wireless device has been measured in all cases requested by the relevant standards cited in Clause 6 of this report. Maximum localized SAR is **below** exposure limits specified in the relevant standards.

SIMULTANEOUS TRANSMISSION ANALYSIS

Test Position		Right Cheek	Right Title	Left Cheek	Left Tilt
Head MAX 1-g SAR(W/Kg)	GSM850	0.050	0.039	0.057	0.041
	GSM1900	0.245	0.060	0.197	0.051
	WCDMA1900	0.166	0.089	0.173	0.090
	WCDMA1700	0.192	0.157	0.240	0.187
	WCDMA850	0.049	0.031	0.054	0.039
	LTE Band2	0.166	0.085	0.159	0.081
	LTE Band4	0.160	0.122	0.185	0.127
	LTE Band7	0.075	0.048	0.071	0.045



	LTE Band17	0.079	0.055	0.072	0.054
	WIFI 802.11b	0.377	0.497	0.374	0.480
	BT	*0.261	*0.261	*0.261	*0.261
BT Simultaneous Σ 1-g SAR(W/Kg)		0.506	0.418	0.501	0.448
WiFi Simultaneous Σ 1-g SAR(W/Kg)		0.622	0.654	0.614	0.667

Simultaneous Tx Combination of GSM/WCDMA/LTE and BT/WIFI (Head).

Test Position		Face	Back	Edge A	Edge B	Edge C	Edge D
Body-worn 10mm separation MAX 1-g SAR(W/Kg)	GSMS850	0.060	0.086	--	--	--	--
	GSM1900	0.242	0.255	--	--	--	--
	WCDMA1900	0.428	0.414	--	--	--	--
	WCDMA1700	0.624	0.716	--	--	--	--
	WCDMA850	0.092	0.122	--	--	--	--
	LTE Band2	0.295	0.438	--	--	--	--
	LTE Band4	0.539	0.666	--	--	--	--
	LTE Band7	0.3393	0.851	--	--	--	--
	LTE Band17	0.120	0.151	--	--	--	--
	WIFI 802.11b	0.079	0.103	--	--	--	--
	BT	*0.130	*0.130	--	--	--	--
BT Simultaneous Σ 1-g SAR(W/Kg)		0.754	0.981	--	--	--	--
WiFi Simultaneous Σ 1-g SAR(W/Kg)		0.703	0.954	--	--	--	--

Simultaneous Tx Combination of GSM/WCDMA/LTE and BT/WIFI (Body).

Test Position		Face	Back	Edge A	Edge B	Edge C	Edge D
Hotspot 10mm separation MAX 1-g SAR(W/Kg)	GPRS850	0.071	0.101	--	0.045	0.030	0.059
	GPRS1900	0.219	0.177	--	0.099	0.405	0.057
	WCDMA1900	0.428	0.414	--	0.201	0.828	0.124
	WCDMA1700	0.624	0.716	--	0.245	0.609	0.107
	WCDMA850	0.092	0.122	--	0.051	0.013	0.086
	LTE Band2	0.295	0.438	--	0.206	0.665	0.165
	LTE Band4	0.539	0.666	--	0.216	0.506	0.061
	LTE Band7	0.393	0.851	--	0.088	1.118	0.017
	LTE Band17	0.120	0.151	--	0.039	0.024	0.085
	WIFI 802.11b	0.079	0.103		--	--	0.037
	BT	*0.130	*0.130	*0.130	--	--	*0.130
BT Simultaneous Σ 1-g SAR(W/Kg)		0.754	0.981	0.130	--	1.118	0.202
WiFi Simultaneous Σ 1-g SAR(W/Kg)		0.703	0.954	0.097	--	1.118	0.295

Simultaneous Tx Combination of GSM/WCDMA/LTE and WIFI (Body).

The estimated SAR value with * Signal

SAR to Peak Location Separation Ratio (SPLSR)

As the Sum of the SAR is not greater than 1.6 W/kg SPLSR assessment is not required

11 Measurement Uncertainty

No.	Uncertainty Component	Type	Uncertainty Value (%)	Probability Distribution	k	ci	Standard Uncertainty (%) $u_i(\%)$	Degree of freedom ν_{eff} or ν_i
Measurement System								
1	–Probe Calibration	B	5.8	N	1	1	5.8	∞
2	–Axial isotropy	B	3.5	R	$\sqrt{3}$	0.5	1.43	∞
3	–Hemispherical Isotropy	B	5.9	R	$\sqrt{3}$	0.5	2.41	∞
4	–Boundary Effect	B	1	R	$\sqrt{3}$	1	0.58	∞
5	–Linearity	B	4.7	R	$\sqrt{3}$	1	2.71	∞
6	–System Detection Limits	B	1.0	R	$\sqrt{3}$	1	0.58	∞
7	Modulation response	B	3	N	1	1	3.00	
8	–Readout Electronics	B	0.5	N	1	1	0.50	∞
9	–Response Time	B	1.4	R	$\sqrt{3}$	1	0.81	∞
10	–Integration Time	B	3.0	R	$\sqrt{3}$	1	1.73	∞
11	–RF Ambient Conditions	B	3.0	R	$\sqrt{3}$	1	1.73	∞
12	–Probe Position Mechanical tolerance	B	1.4	R	$\sqrt{3}$	1	0.81	∞
13	–Probe Position with respect to Phantom Shell	B	1.4	R	$\sqrt{3}$	1	0.81	∞
14	–Extrapolation, Interpolation and Integration Algorithms for Max. SAR evaluation	B	2.3	R	$\sqrt{3}$	1	1.33	∞
Uncertainties of the DUT								
15	–Position of the DUT	A	2.6	N	$\sqrt{3}$	1	2.6	5
16	–Holder of the DUT	A	3	N	$\sqrt{3}$	1	3.0	5



17	–Output Power Variation –SAR drift measurement	B	5.0	R	$\sqrt{3}$	1	2.89	∞
Phantom and Tissue Parameters								
18	– Phantom Uncertainty(shape and thickness tolerances)	B	4	R	$\sqrt{3}$	1	2.31	∞
19	Uncertainty in SAR correction for deviation(in permittivity and conductivity)	B	2	N	1	1	2.00	
20	–Liquid Conductivity Target –tolerance	B	2.5	R	$\sqrt{3}$	0.6	1.95	∞
21	–Liquid Conductivity –measurement Uncertainty)	B	4	N	$\sqrt{3}$	1	0.92	9
22	–Liquid Permittivity Target tolerance	B	2.5	R	$\sqrt{3}$	0.6	1.95	∞
23	–Liquid Permittivity –measurement uncertainty	B	5	N	$\sqrt{3}$	1	1.15	∞
Combined Standard Uncertainty				RSS			10.63	
Expanded uncertainty (Confidence interval of 95 %)				K=2			21.26	

System Check Uncertainty

No.	Uncertainty Component	Type	Uncertainty Value (%)	Probability Distribution	k	ci	Standard Uncertainty (%) $u_i(\%)$	Degree of freedom v_{eff} or v_i
Measurement System								
1	–Probe Calibration	B	5.8	N	1	1	5.8	∞
2	–Axial isotropy	B	3.5	R	$\sqrt{3}$	0.5	1.43	∞
3	–Hemispherical Isotropy	B	5.9	R	$\sqrt{3}$	0.5	2.41	∞
4	–Boundary Effect	B	1	R	$\sqrt{3}$	1	0.58	∞
5	–Linearity	B	4.7	R	$\sqrt{3}$	1	2.71	∞
6	–System Detection Limits	B	1	R	$\sqrt{3}$	1	0.58	∞
7	Modulation response	B	0	N	1	1	0.00	



8	–Readout Electronics	B	0.5	N	1	1	0.50	∞
9	– Response Time	B	0.00	R	$\sqrt{3}$	1	0.00	∞
10	– Integration Time	B	1.4	R	$\sqrt{3}$	1	0.81	∞
11	–RF Ambient Conditions	B	3.0	R	$\sqrt{3}$	1	1.73	∞
12	–Probe Position Mechanical tolerance	B	1.4	R	$\sqrt{3}$	1	0.81	∞
13	–Probe Position with respect to Phantom Shell	B	1.4	R	$\sqrt{3}$	1	0.81	∞
14	–Extrapolation, Interpolation and Integration Algorithms for Max. SAR evaluation	B	2.3	R	$\sqrt{3}$	1	1.33	∞
Uncertainties of the DUT								
15	Deviation of experimental source from numerical source	A	4	N	1	1	4.00	5
16	Input Power and SAR drift measurement	A	5	R	$\sqrt{3}$	1	2.89	5
17	Dipole Axis to Liquid Distance	B	2	R	$\sqrt{3}$	1	1.2	∞
Phantom and Tissue Parameters								
18	–Phantom Uncertainty(shape and thickness tolerances)	B	4	R	$\sqrt{3}$	1	2.31	∞
19	Uncertainty in SAR correction for deviation(in permittivity and conductivity)	B	2	N	1	1	2.00	
20	–Liquid Conductivity Target –tolerance	B	2.5	R	$\sqrt{3}$	0.6	1.95	∞
21	–Liquid Conductivity –measurement Uncertainty)	B	4	N	$\sqrt{3}$	1	0.92	9
22	–Liquid Permittivity Target tolerance	B	2.5	R	$\sqrt{3}$	0.6	1.95	∞
23	–Liquid Permittivity –measurement uncertainty	B	5	N	$\sqrt{3}$	1	1.15	∞
Combined Standard Uncertainty					RSS		10.15	
Expanded uncertainty (Confidence interval of 95 %)					K=2		20.29	

**12 MAIN TEST INSTRUMENTS**

EQUIPMENT	TYPE	Series No.	Calibration Date	calibration period
System Simulator	E5515C	GB 47200710	2015/06/10	1 Year
System Simulator	CMW500	130805	2015/08/10	1 Year
SAR Probe	SATIMO	SN_0413_EP166	2015/08/10	1 Year
SAR Probe	SATIMO	SN09/13 EP169	2015/05/04	1 Year
Dipole	SID750	SN23/15 DIP0G750-378	2015/06/01	1 Year
Dipole	SID835	SN09/13 DIP0G835-217	2014/08/28	2 Year
Dipole	SID1800	SN09/13 DIP1G800-216	2014/08/28	2 Year
Dipole	SID1900	SN09/13 DIP1G900-218	2014/08/28	2 Year
Dipole	SID2450	SN09/13 DIP2G450-220	2014/08/28	2 Year
Dipole	SID2600	SN32/14 DIP2G600-338	2014/08/12	2 Year
Vector Network Analyzer	ZVB8	A0802530	2015/06/08	1 Year
Signal Generator	SMR27	A0304219	2015/06/08	1 Year
Power Meter	NRP2	A140401673	2015/03/27	1 Year
Power Sensor	NPR-Z11	1138.3004.02-114072-nq	2015/03/27	1 Year
Amplifier	Nucletudes	143060	2015/03/27	1 Year
Directional Coupler	DC6180A	305827	2015/03/27	1 Year
Power Meter	NRVS	A0802531	2015/03/27	1 Year
Power Sensor	NRV-Z4	100069	2015/03/27	1 Year
Multimeter	Keithley-2000	4014020	2015/03/27	1 Year



ANNEX A

of

CCIC-SET

CONFORMANCE TEST REPORT FOR

HUMAN EXPOSURE TO ELECTROMAGNETIC FIELDS

SET2015-16860

Mobile phone

Type Name: L52\L50a

Hardware Version: H01

Software Version: V01

TEST SETUP

This Annex consists of 7 pages

Date of Report: 2015-11-27

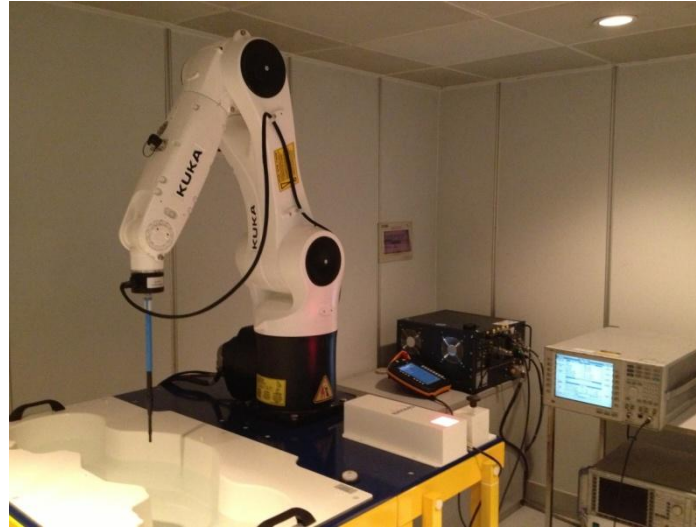

Fig.1 COMO SAR Test System

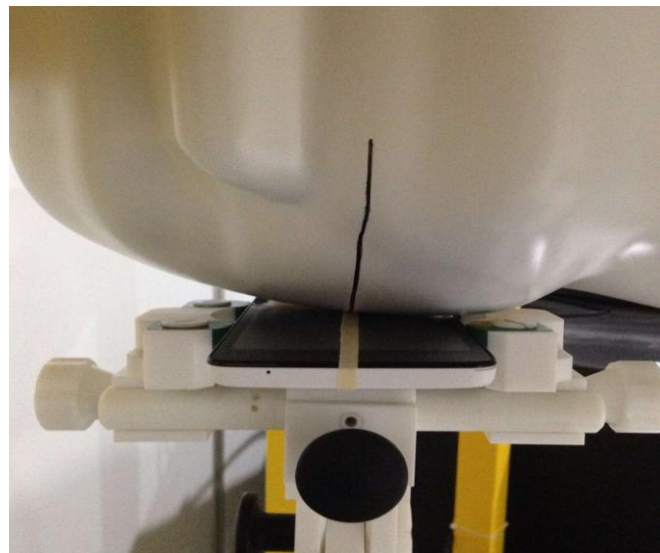

Fig.2 Right_Cheek

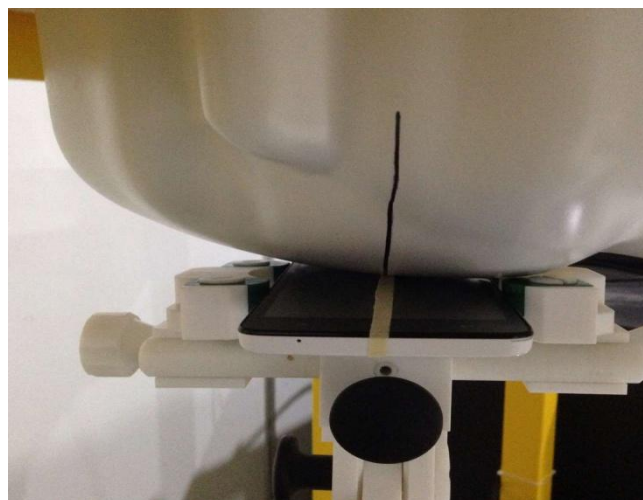

Fig.3 Right_Tilt

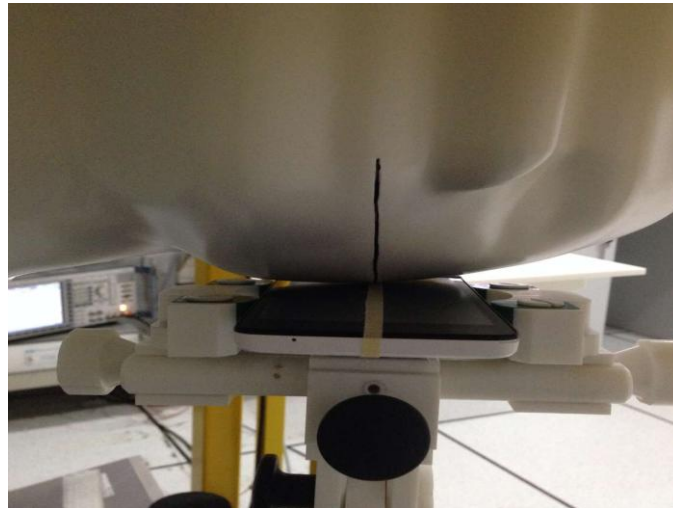

Fig.4 Left Cheek

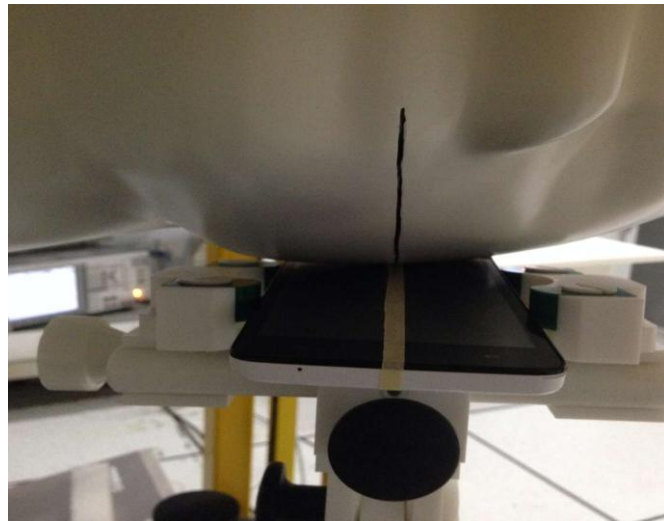

Fig.5 Left_Tilt



Fig.6 Body (Back upside,10mm separation)



Fig.7 Body (Face upside,10mm separation)

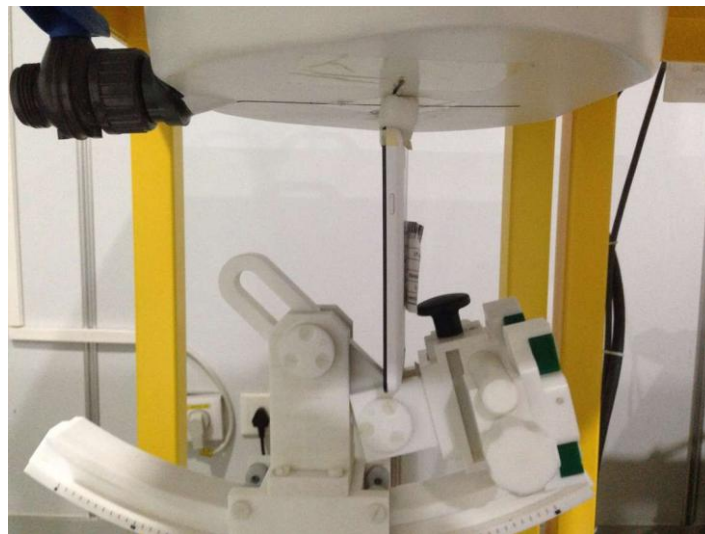

Fig.8 Body Edge A(UP,10mm separation)

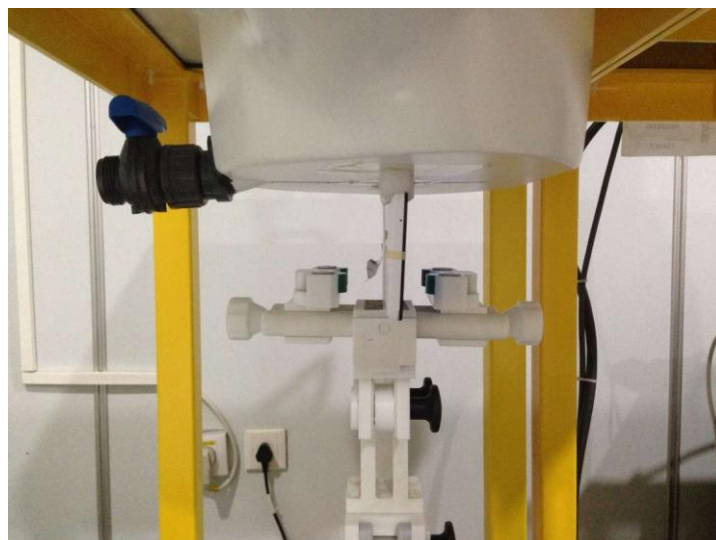

Fig.9 Body Edge B(UP,10mm separation)

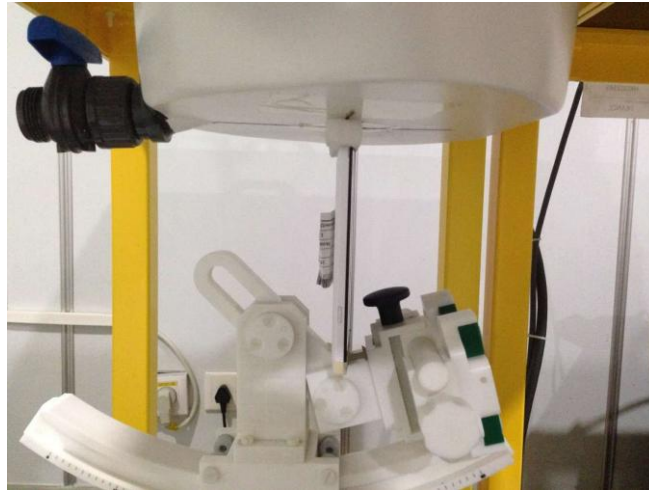

Fig.10 Body Edge C(UP,10mm separation)



Fig.11 Body Edge D(Right upside,10mm separation)

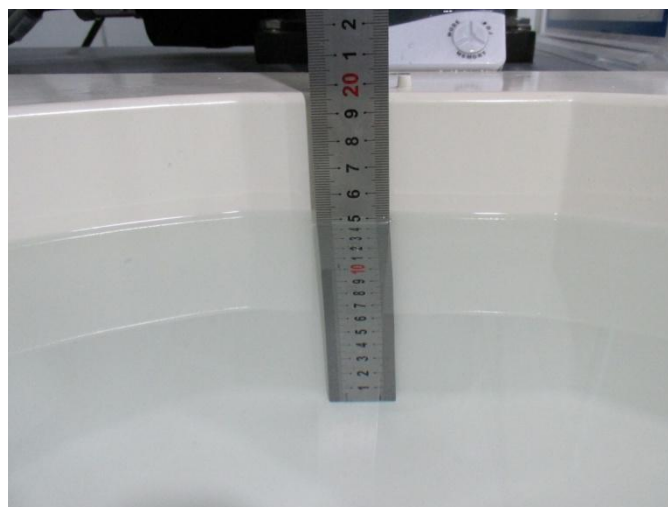

Fig.12 Head Liquid of 850MHz(15cm)



Fig.13 Body Liquid of 850MHz (15cm)



Fig.14 Head Liquid of 1800-1900MHz(15cm)



Fig.15 Body Liquid of 1800-1900MHz(15cm)



Fig.16 Head Liquid of 2450-2600MHz(15cm)



Fig.17 Body Liquid of 2450-2600MHz(15cm)



Fig.18 Head Liquid of 750MHz(15cm)



Fig.19 Body Liquid of 750MHz (15cm)



ANNEX B
of
CCIC-SET

CONFORMANCE TEST REPORT FOR
HUMAN EXPOSURE TO ELECTROMAGNETIC FIELDS

SET2015-16860

Mobile phone

Type Name: L52\L50a

Hardware Version: H01

Software Version: V01

Sample Photographs

This Annex consists of 2 pages

Date of Report: 2015-11-27

1. Appearance



Appearance and size (obverse)



Appearance and size (reverse)



ANNEX C

of

CCIC-SET

CONFORMANCE TEST REPORT FOR

HUMAN EXPOSURE TO ELECTROMAGNETIC FIELDS

SET2015-16860

Mobile phone

Type Name: L52\L50a

Hardware Version: H01

Software Version: V01

System Performance Check Data and Highest SAR Plots

This Annex consists of 35 pages

Date of Report: 2015-11-27

System Performance Check (Head, 750MHz)

Type: Validation measurement

Area scan resolution: dx=8mm,dy=8mm

Zoom scan resolution: dx=8mm, dy=8mm, dz=5mm

Date of measurement:13/11/2015

Measurement duration: 21 minutes 24 seconds

A. Experimental conditions.

Phantom File	dx=8mm dy=8mm
Phantom	5x5x7,dx=8mm dy=8mm dz=5mm
Device Position	
Band	750MHz
Channels	
Signal	CW

B. SAR Measurement Results

Band SAR

E-Field Probe	SATIMO SN_09/13_EP169
Frequency (MHz)	750
Relative permittivity (real part)	41.71
Relative permittivity	21.12
Conductivity (S/m)	0.88
Power drift (%)	0.54
Ambient Temperature:	23.2 °C
Liquid Temperature:	23.5 °C
ConvF:	5.26
Duty factor:	1:1

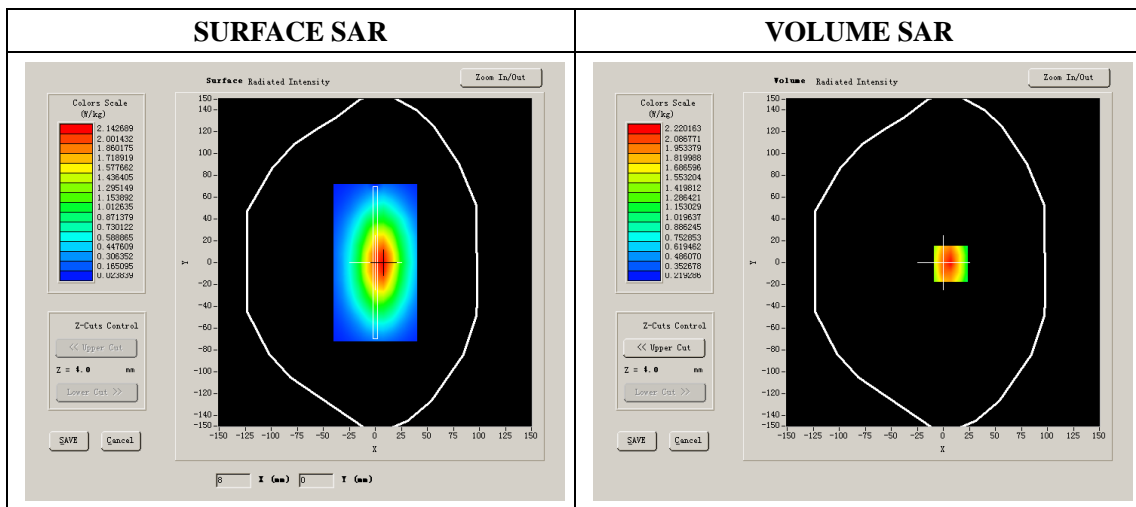

Maximum location: X=7.00, Y=-1.00

SAR 10g (W/Kg)	1.134368
SAR 1g (W/Kg)	2.096874

System Performance Check (Head, 850MHz)

Type: Validation measurement

Area scan resolution: dx=8mm,dy=8mm

Zoom scan resolution: dx=8mm, dy=8mm, dz=5mm

Date of measurement:13/11/2015

Measurement duration: 21 minutes 24 seconds

A. Experimental conditions.

Phantom File	dx=8mm dy=8mm
Phantom	5x5x7,dx=8mm dy=8mm dz=5mm
Device Position	
Band	850MHz
Channels	
Signal	CW

B. SAR Measurement Results

Band SAR

E-Field Probe	SATIMO SN_04/13_EP166
Frequency (MHz)	850
Relative permittivity (real part)	41.36
Relative permittivity	18.97
Conductivity (S/m)	0.88
Power drift (%)	-1.31
Ambient Temperature:	23.2 °C
Liquid Temperature:	23.5 °C
ConvF:	5.69
Duty factor:	1:1

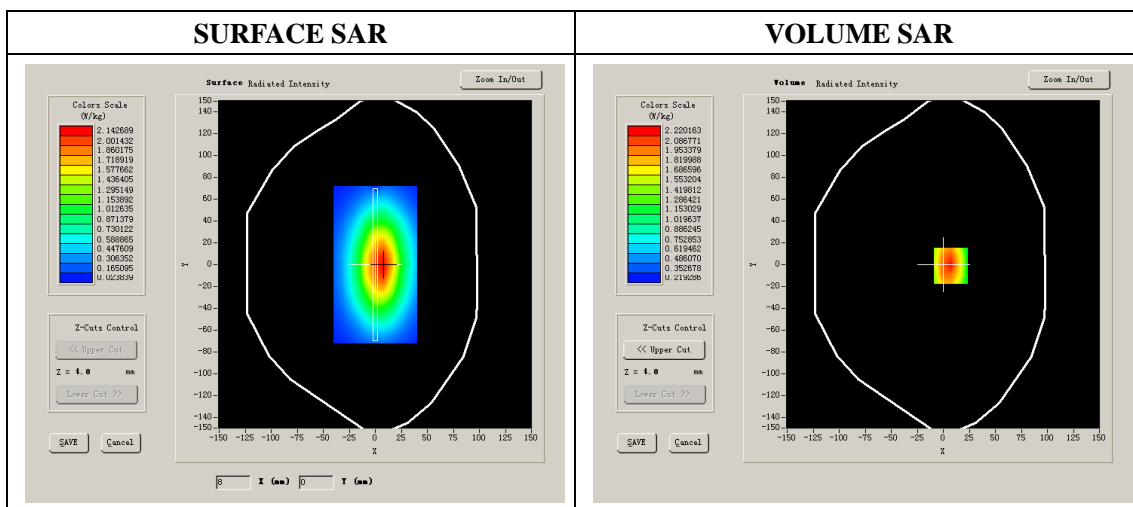

Maximum location: X=7.00, Y=-1.00

SAR 10g (W/Kg)	1.813603
SAR 1g (W/Kg)	2.403872

System Performance Check (Head, 1800MHz)

Type: Validation measurement

Area scan resolution: dx=8mm,dy=8mm

Zoom scan resolution: dx=8mm, dy=8mm, dz=5mm

Date of measurement: 14/11/2015

Measurement duration: 20 minutes 52seconds

A. Experimental conditions.

Phantom File	dx=8mm dy=8mm
Phantom	5x5x7,dx=8mm dy=8mm dz=5mm
Device Position	
Band	1800MHz
Channels	
Signal	CW

B. SAR Measurement Results

Band SAR

E-Field Probe	SATIMO SN_04/13_EP166
Frequency (MHz)	1800
Relative permittivity (real part)	39.75
Relative permittivity	13.90
Conductivity (S/m)	1.39
Power drift (%)	-2.07
Ambient Temperature:	22.2 °C
Liquid Temperature:	22.5 °C
ConvF:	4.75
Duty factor:	1:1

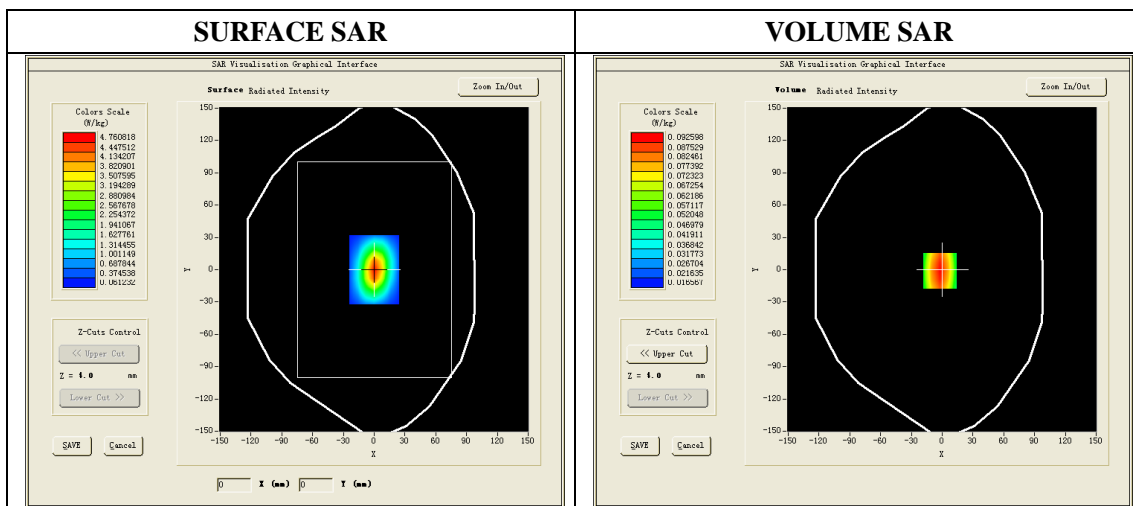

Maximum location: X=6.00, Y=0.00

SAR 10g (W/Kg)	4.993571
SAR 1g (W/Kg)	9.473650

System Performance Check (Head, 1900MHz)

Type: Validation measurement

Area scan resolution: dx=8mm,dy=8mm

Zoom scan resolution: dx=8mm, dy=8mm, dz=5mm

Date of measurement: 14/11/2015

Measurement duration: 22 minutes 32 seconds

A. Experimental conditions.

Phantom File	dx=8mm dy=8mm
Phantom	5x5x7,dx=8mm dy=8mm dz=5mm
Device Position	
Band	1900MHz
Channels	
Signal	CW

B. SAR Measurement Results

Band SAR

E-Field Probe	SATIMO SN_04/13_EP166
Frequency (MHz)	1900.000000
Relative permittivity (real part)	39.85
Relative permittivity	13.17
Conductivity (S/m)	1.39
Power drift (%)	0.17
Ambient Temperature:	22.2 °C
Liquid Temperature:	22.5 °C
ConvF:	5.25
Duty factor:	1:1

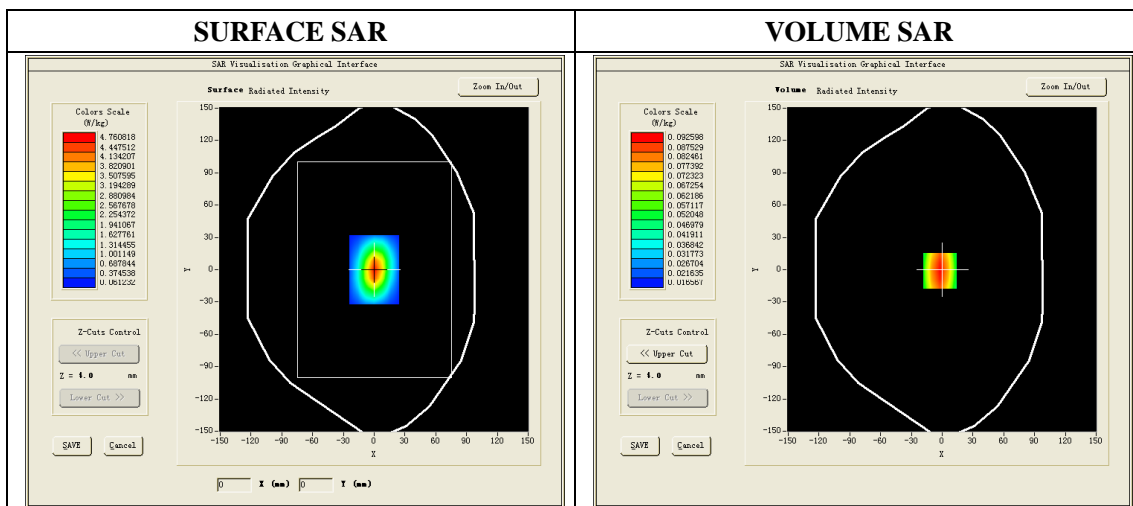

Maximum location: X=6.00, Y=0.00

SAR 10g (W/Kg)	5.156357
SAR 1g (W/Kg)	9.848365

System Performance Check (Head, 2450MHz)

Type: Phone measurement

Area scan resolution: dx=8mm,dy=8mm

Zoom scan resolution: dx=5mm dy=5mm dz=4mm

Date of measurement:16/11/2015

Measurement duration: 21 minutes 24 seconds

A. Experimental conditions.

Phantom File	dx=8mm dy=8mm
Phantom	7x7x8,dx=5mm dy=5mm dz=4mm
Device Position	Dipole
Band	2450MHz
Channels	
Signal	CW

B. SAR Measurement Results

Band SAR

E-Field Probe	SATIMO SN_04/13_EP166
Frequency (MHz)	2450
Relative permittivity (real part)	38.94
Relative permittivity	13.15
Conductivity (S/m)	1.79
Power Drift (%)	0.35
ConvF:	4.93
Duty factor:	1:1

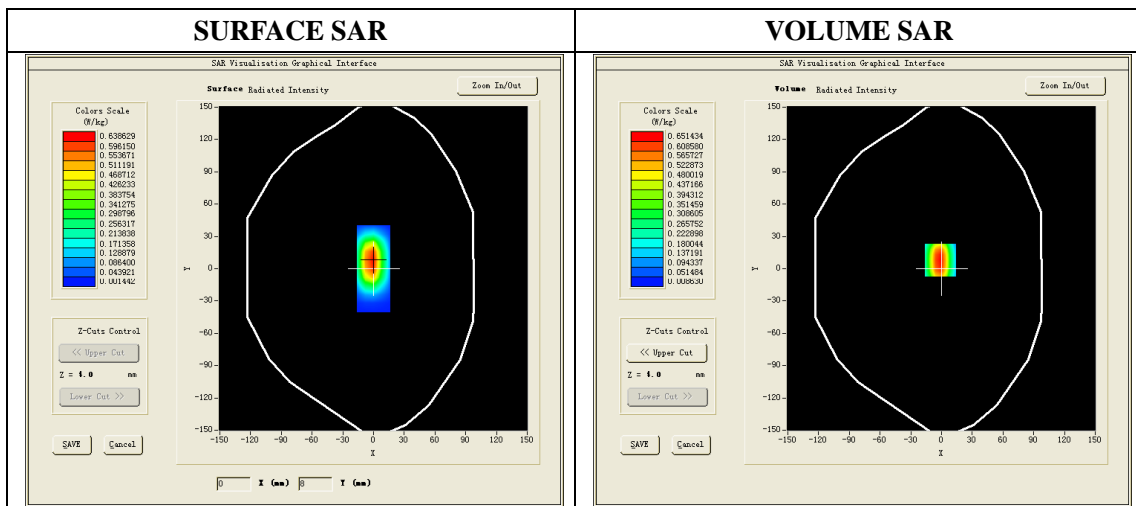

Maximum location: X=0.00, Y=8.00

SAR 10g (W/Kg)	5.913520
SAR 1g (W/Kg)	13.163574

System Performance Check (Head,2600MHz)

Type: Phone measurement

Area scan resolution: dx=8mm,dy=8mm

Zoom scan resolution: dx=5mm, dy=5mm, dz=4mm

Date of measurement: 16/11/2015

Measurement duration: 22 minutes 21 seconds

A. Experimental conditions.

Phantom File	dx=8mm dy=8mm
Phantom	7x7x8,dx=5mm dy=5mm dz=4mm
Device Position	Dipole
Band	2600MHz
Channels	
Signal	CW

B. SAR Measurement Results

Band SAR

E-Field Probe	SATIMO SN_04/13_EP166
Frequency (MHz)	2600
Relative permittivity (real part)	38.89
Relative permittivity	13.36
Conductivity (S/m)	1.93
Power drift (%)	-0.42
Ambient Temperature:	22.2°C
Liquid Temperature:	22.5°C
Crest factor:	1:1
ConvF:	5.08

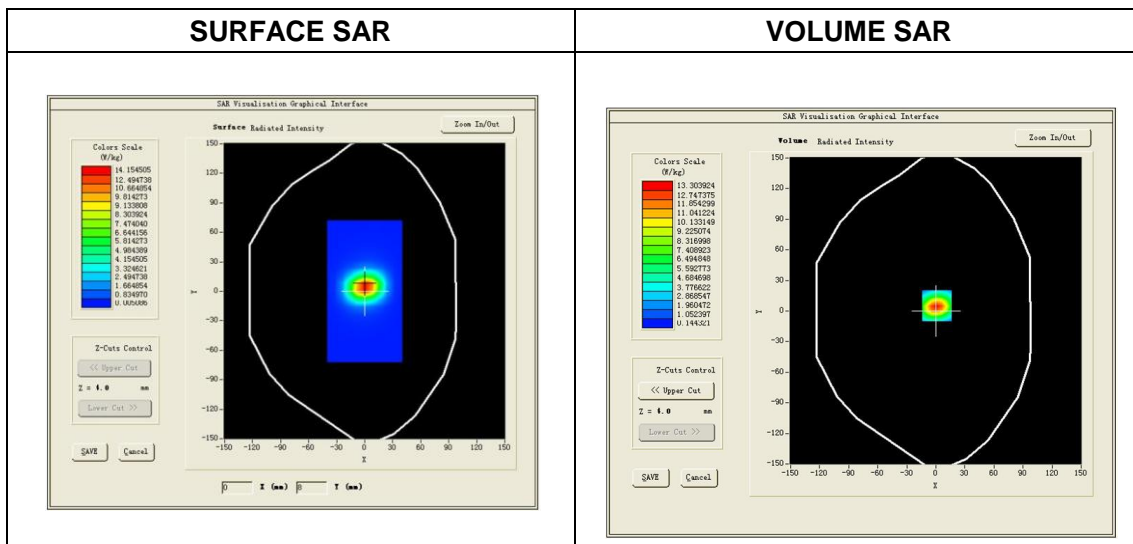

Maximum location: X=1.00, Y=5.00

SAR 10g (W/Kg)	5.953674
SAR 1g (W/Kg)	13.942837

System Performance Check (Body, 750MHz)

Type: Validation measurement

Area scan resolution: dx=8mm,dy=8mm

Zoom scan resolution: dx=8mm, dy=8mm, dz=5mm

Date of measurement: 17/11/2015

Measurement duration: 20 minutes 12 seconds

A. Experimental conditions.

Phantom File	dx=8mm dy=8mm
Phantom	5x5x7,dx=8mm dy=8mm dz=5mm
Device Position	Dipole
Band	750MHz
Channels	
Signal	CW

B. SAR Measurement Results

Band SAR

E-Field Probe	SATIMO SN_09/13_EP169
Frequency (MHz)	750
Relative permittivity (real part)	55.01
Relative permittivity	22.80
Conductivity (S/m)	0.95
Power drift (%)	-3.08
Ambient Temperature:	22.2 °C
Liquid Temperature:	22.5 °C
ConvF:	5.41
Duty factor:	1:1

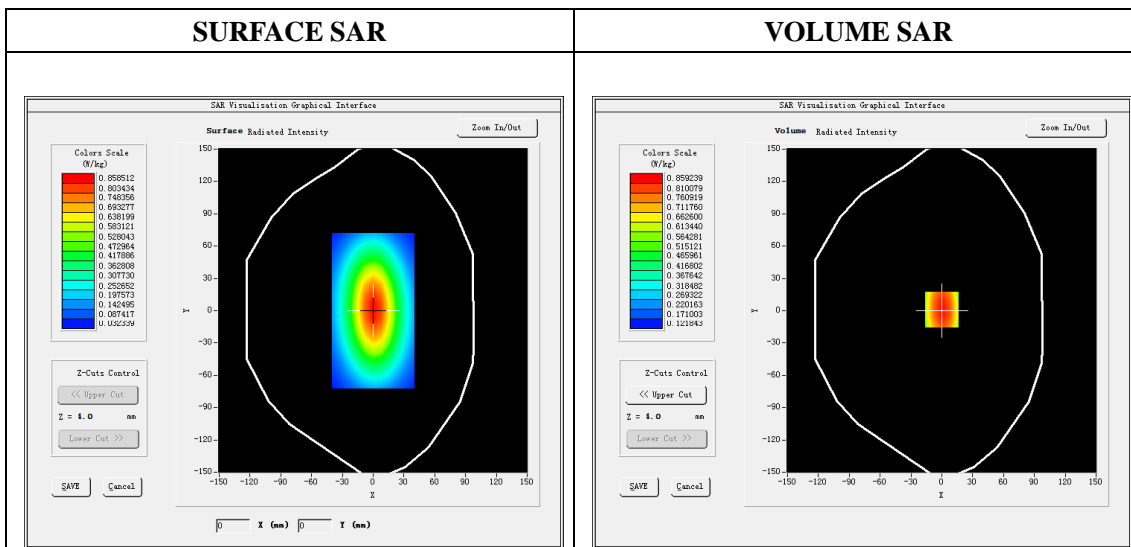

Maximum location: X=0.00, Y=1.00

SAR 10g (W/Kg)	0.996423
SAR 1g (W/Kg)	2.012576

System Performance Check (Body, 850MHz)

Type: Validation measurement

Area scan resolution: dx=8mm,dy=8mm

Zoom scan resolution: dx=8mm, dy=8mm, dz=5mm

Date of measurement: 17/11/2015

Measurement duration: 20 minutes 12 seconds

A. Experimental conditions.

Phantom File	dx=8mm dy=8mm
Phantom	5x5x7,dx=8mm dy=8mm dz=5mm
Device Position	Dipole
Band	835MHz
Channels	
Signal	CW

B. SAR Measurement Results

Band SAR

E-Field Probe	SATIMO SN_04/13_EP166
Frequency (MHz)	850
Relative permittivity (real part)	55.32
Relative permittivity	20.12
Conductivity (S/m)	0.95
Power drift (%)	-0.31
Ambient Temperature:	22.2 °C
Liquid Temperature:	22.5 °C
ConvF:	5.82
Duty factor:	1:1

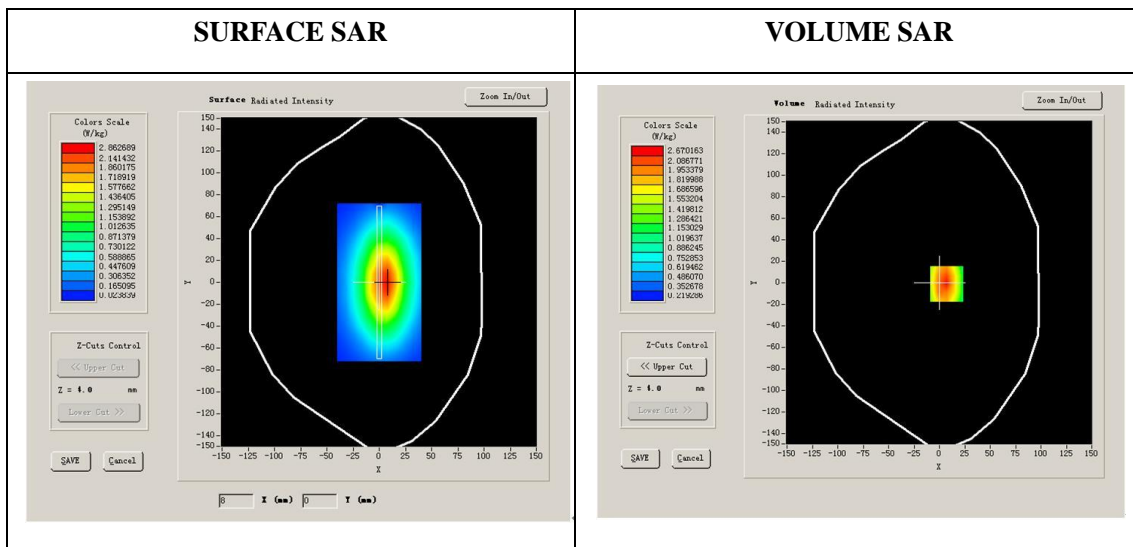

Maximum location: X=7.00, Y=-1.00

SAR 10g (W/Kg)	1.631452
SAR 1g (W/Kg)	2.523687

System Performance Check (Body, 1800MHz)

Type: Phone measurement

Area scan resolution: dx=8mm,dy=8mm

Zoom scan resolution: dx=8mm, dy=8mm, dz=5mm

Date of measurement: 18/11/2015

Measurement duration: 20 minutes 06 seconds

A. Experimental conditions.

Phantom File	dx=8mm dy=8mm
Phantom	5x5x7,dx=8mm dy=8mm dz=5mm
Device Position	Dipole
Band	1800MHz
Channels	
Signal	CW

B. SAR Measurement Results

Band SAR

E-Field Probe	SATIMO SN_04/13_EP166
Frequency (MHz)	1800
Relative permittivity (real part)	53.37
Relative permittivity	15.00
Conductivity (S/m)	1.50
Power drift (%)	-0.39
Ambient Temperature:	22.2 °C
Liquid Temperature:	22.6 °C
ConvF:	4.96
Crest factor:	1:1

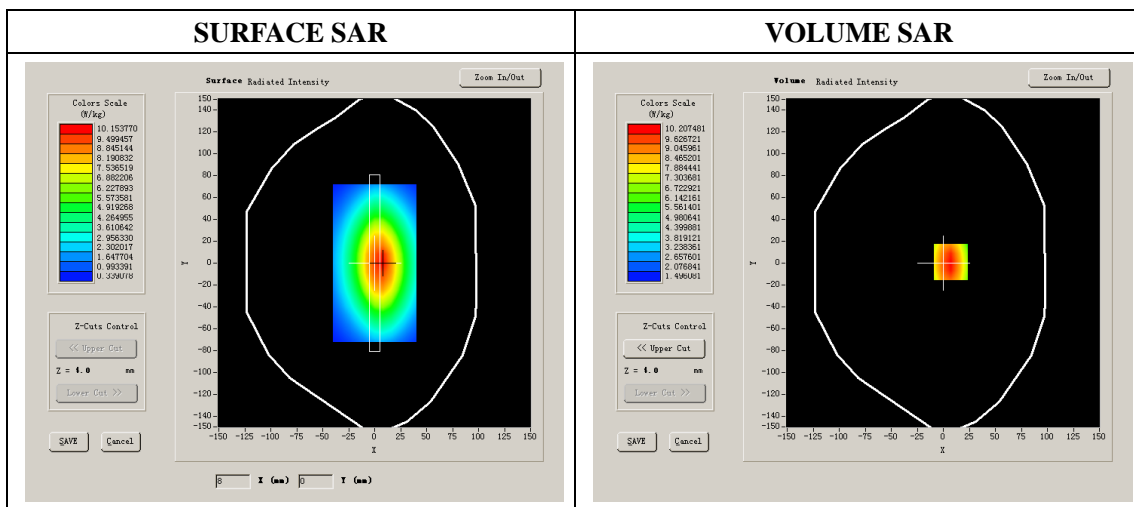

Maximum location: X=7.00, Y=1.00

SAR 10g (W/Kg)	5.020572
SAR 1g (W/Kg)	9.831277

System Performance Check (Body, 1900MHz)

Type: Validation measurement

Area scan resolution: dx=8mm,dy=8mm

Zoom scan resolution: dx=8mm, dy=8mm, dz=5mm

Date of measurement: 18/11/2015

Measurement duration: 21 minutes 34 seconds

A. Experimental conditions.

Phantom File	dx=8mm dy=8mm
Phantom	5x5x7,dx=8mm dy=8mm dz=5mm
Device Position	Dipole
Band	1900MHz
Channels	
Signal	CW

B. SAR Measurement Results

Band SAR

E-Field Probe	SATIMO SN_04/13_EP166
Frequency (MHz)	1900
Relative permittivity (real part)	53.14
Relative permittivity	14.40
Conductivity (S/m)	1.52
Power Drift (%)	-0.68
Ambient Temperature:	22.1 °C
Liquid Temperature:	22.6 °C
ConvF:	5.43
Duty factor:	1:1

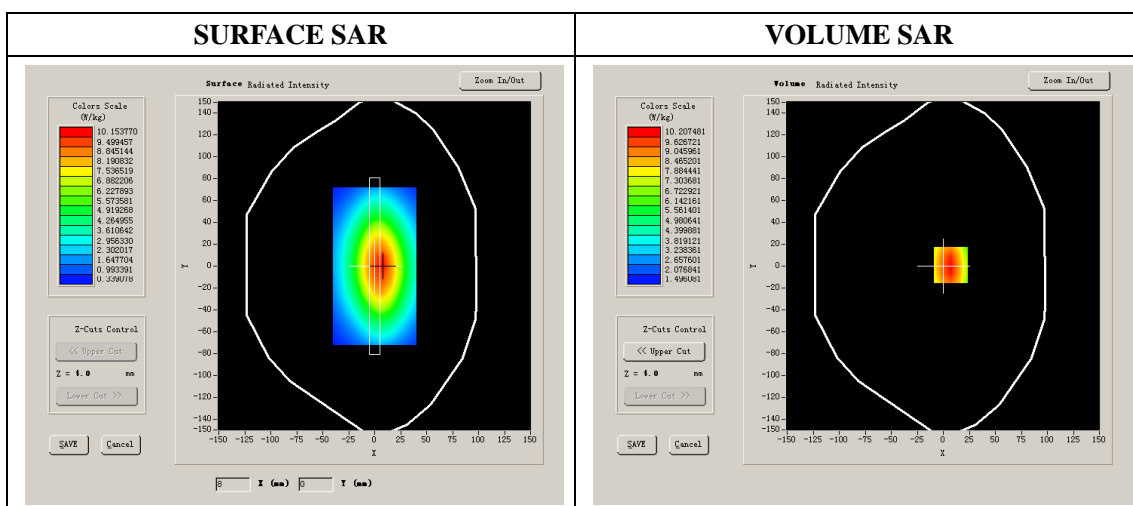

Maximum location: X=1.00, Y=6.00

SAR 10g (W/Kg)	5.268423
SAR 1g (W/Kg)	10.108358

System Performance Check (Body, 2450MHz)

Type: Phone measurement

Area scan resolution: dx=8mm,dy=8mm

Zoom scan resolution: dx=5mm, dy=5mm, dz=4mm

Date of measurement: 19/11/2015

Measurement duration: 22 minutes 21 seconds

A. Experimental conditions.

Phantom File	dx=8mm dy=8mm
Phantom	7x7x8,dx=5mm dy=5mm dz=4mm
Device Position	Dipole
Band	2450MHz
Channels	
Signal	CW

B. SAR Measurement Results

Band SAR

E-Field Probe	SATIMO SN_04/13_EP166
Frequency (MHz)	2450
Relative permittivity (real part)	52.53
Relative permittivity	14.25
Conductivity (S/m)	1.94
Power Drift (%)	-0.31
Duty factor:	1:1
ConvF:	5.09

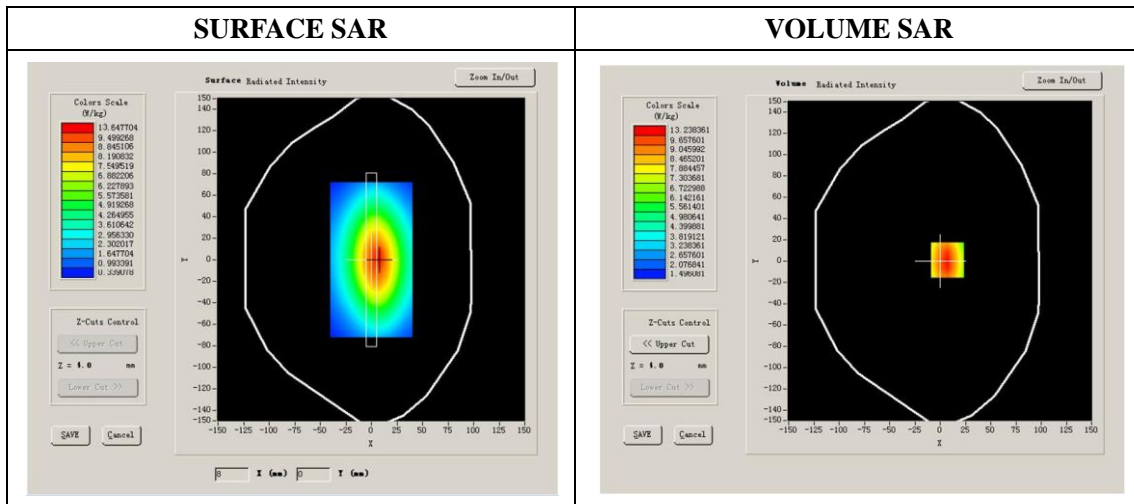

Maximum location: X=0.00, Y=8.00

SAR 10g (W/Kg)	6.050681
SAR 1g (W/Kg)	13.064876

System Performance Check (Body,2600MHz)

Type: Phone measurement

Area scan resolution: dx=8mm,dy=8mm

Zoom scan resolution: dx=5mm, dy=5mm, dz=4mm

Date of measurement: 19/11/2015

Measurement duration: 22 minutes 24 seconds

A. Experimental conditions.

Phantom File	dx=8mm dy=8mm
Phantom	7x7x8,dx=5mm dy=5mm dz=4mm
Device Position	Dipole
Band	2600MHz
Channels	
Signal	CW

B. SAR Measurement Results

Band SAR

E-Field Probe	SATIMO SN_04/13_EP166
Frequency (MHz)	2600
Relative permittivity (real part)	52.56
Relative permittivity	14.88
Conductivity (S/m)	2.15
Power drift (%)	1.35
Ambient Temperature:	22.2°C
Liquid Temperature:	22.5°C
Crest factor:	1:1
ConvF:	5.22

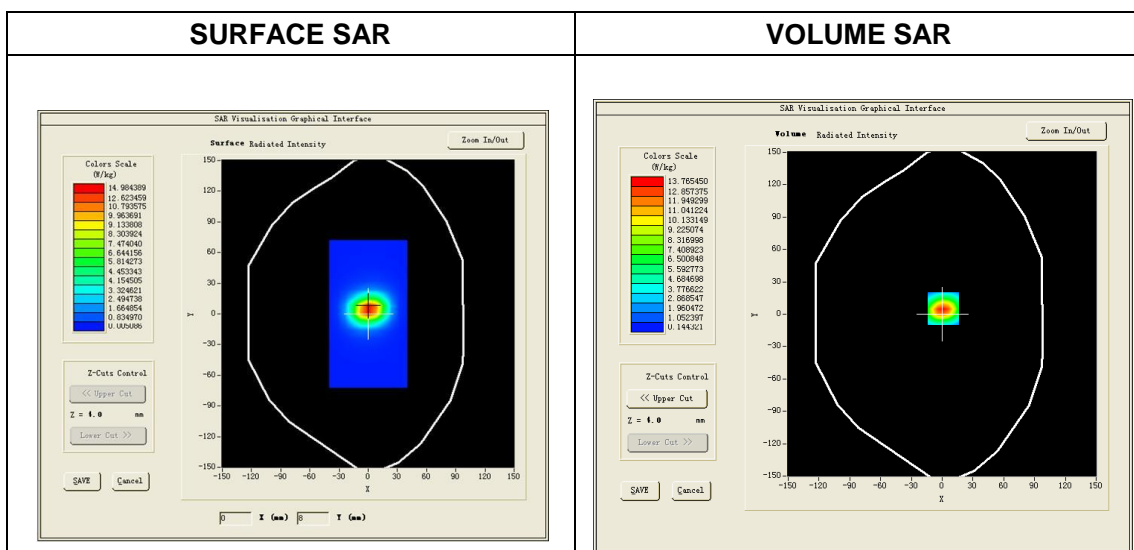

Maximum location: X=1.00, Y=4.00

SAR 10g (W/Kg)	5.987241
SAR 1g (W/Kg)	14.032842

Plot 1: GSM850, Left Cheek, High

Type: Phone measurement
 Date of measurement: 13/11/2015
 Measurement duration: 6 minutes 17 seconds
 Mobile Phone IMEI number: --

A. Experimental conditions.

Area Scan	dx=8mm dy=8mm
ZoomScan	5x5x7,dx=8mm dy=8mm dz=5mm
Phantom	Left head
Device Position	Cheek
Band	GSM850
Channels	251
Signal	GSM (Duty cycle: 1:8)

B. SAR Measurement Results

E-Field Probe	SATIMO SN_04/13_EP166
Frequency (MHz)	848.8
Relative permittivity (real part)	41.36
Relative permittivity (imaginary part)	18.97
Conductivity (S/m)	0.88
Variation (%)	4.80
ConvF:	5.69

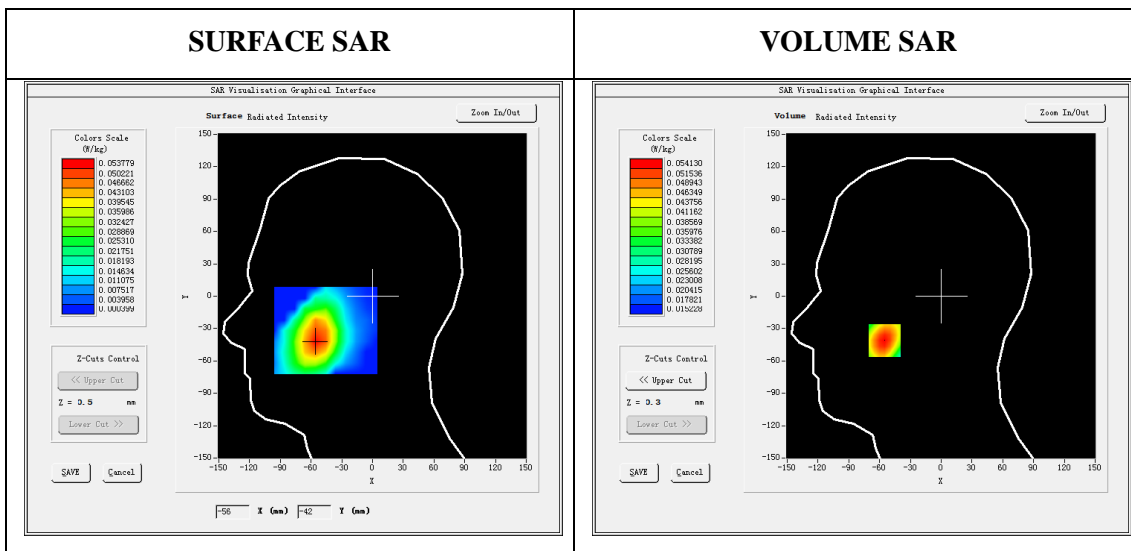

Maximum location: X=-55.00, Y=-41.00
 SAR Peak: 0.06 W/kg

SAR 10g (W/Kg)	0.040942
SAR 1g (W/Kg)	0.051913

Plot 2: GSM850, Back, High

Type: Phone measurement
 Date of measurement: 17/11/2015
 Measurement duration: 7 minutes 02 seconds
 Mobile Phone IMEI number: --

A. Experimental conditions.

Area Scan	dx=8mm dy=8mm
ZoomScan	5x5x7,dx=8mm dy=8mm dz=5mm
Phantom	Validation plane
Device Position	Back
Band	GSM850
Channels	251
Signal	GSM(Duty cycle: 1:8)

B. SAR Measurement Results

E-Field Probe	SATIMO SN_04/13_EP166
Frequency (MHz)	848.8
Relative permittivity (real part)	55.32
Relative permittivity (imaginary part)	20.12
Conductivity (S/m)	0.95
Variation (%)	4.63
ConvF:	5.82

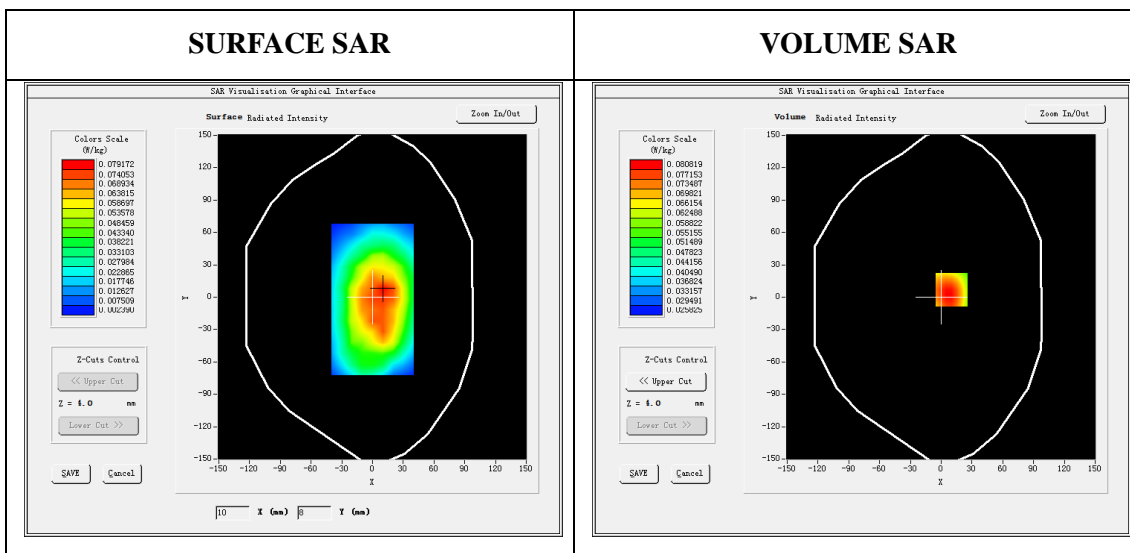

Maximum location: X=10.00, Y=7.00
 SAR Peak: 0.10 W/kg

SAR 10g (W/Kg)	0.058682
SAR 1g (W/Kg)	0.078152

Plot 3: GPRS850, Back, High

Type: Phone measurement
 Date of measurement: 17/11/2015
 Measurement duration: 7 minutes 01 seconds
 Mobile Phone IMEI number: --

A. Experimental conditions.

Area Scan	dx=8mm dy=8mm
ZoomScan	5x5x7,dx=8mm dy=8mm dz=5mm
Phantom	Validation plane
Device Position	Back
Band	GSPRS850_3Tx
Channels	251
Signal	GPRS(Duty cycle: 1:2.67)

B. SAR Measurement Results

E-Field Probe	SATIMO SN_04/13_EP166
Frequency (MHz)	848.8
Relative permittivity (real part)	55.32
Relative permittivity (imaginary part)	20.12
Conductivity (S/m)	0.95
Variation (%)	-1.56
ConvF:	5.82

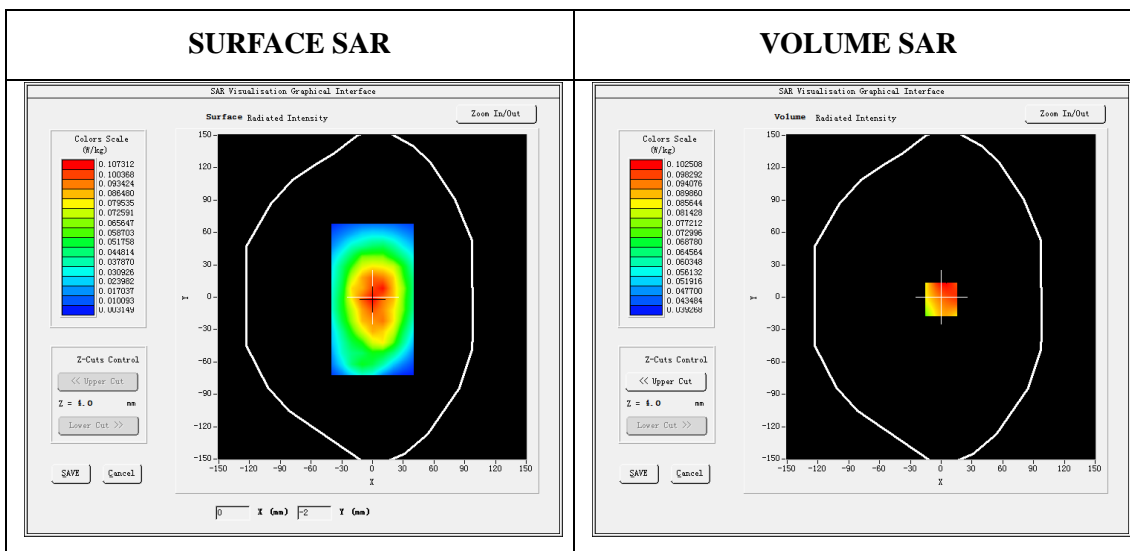

Maximum location: X=0.00, Y=2.00
 SAR Peak: 0.12 W/kg

SAR 10g (W/Kg)	0.078201
SAR 1g (W/Kg)	0.098538

Plot 4: GSM1900, Right Cheek, High

Type: Phone measurement
 Date of measurement: 14/11/2015
 Measurement duration: 6 minutes 53 seconds
 Mobile Phone IMEI number: --

A. Experimental conditions.

Area Scan	dx=8mm dy=8mm
ZoomScan	5x5x7,dx=8mm dy=8mm dz=5mm
Phantom	Right head
Device Position	Cheek
Band	GSM1900
Channels	661
Signal	GSM (Duty cycle: 1:8)

B. SAR Measurement Results

E-Field Probe	SATIMO SN_04/13_EP166
Frequency (MHz)	1909.8
Relative permittivity (real part)	39.85
Relative permittivity (imaginary part)	13.17
Conductivity (S/m)	1.39
Variation (%)	-3.27
ConvF:	5.25

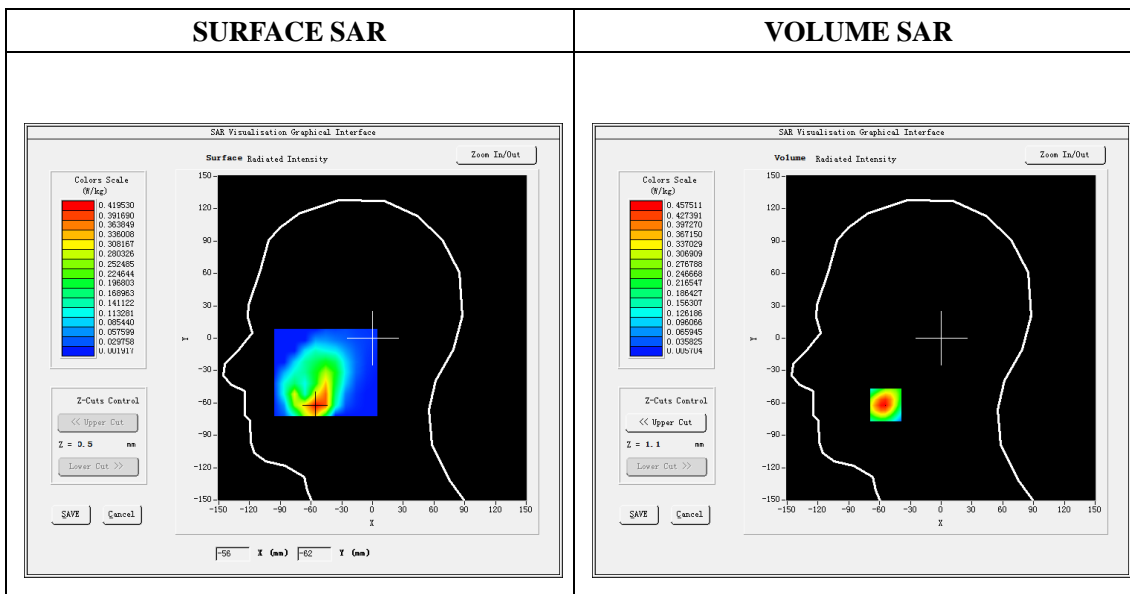

Maximum location: X=-54.00, Y=-62.00
 SAR Peak: 0.84 W/kg

SAR 10g (W/Kg)	0.210207
SAR 1g (W/Kg)	0.228065

Plot 5: GSM1900, Back, High

Type: Phone measurement
 Date of measurement: 18/11/2015
 Measurement duration: 6 minutes 32 seconds
 Mobile Phone IMEI number: --

A. Experimental conditions.

Area Scan	dx=8mm dy=8mm
ZoomScan	5x5x7,dx=8mm dy=8mm dz=5mm
Phantom	Validation plane
Device Position	Back
Band	GSM1900
Channels	661
Signal	GSM (Duty cycle: 1:8)

B. SAR Measurement Results

E-Field Probe	SATIMO SN_04/13_EP166
Frequency (MHz)	1909.8
Relative permittivity (real part)	53.14
Relative permittivity (imaginary part)	14.40
Conductivity (S/m)	1.52
Variation (%)	4.03
ConvF:	5.43

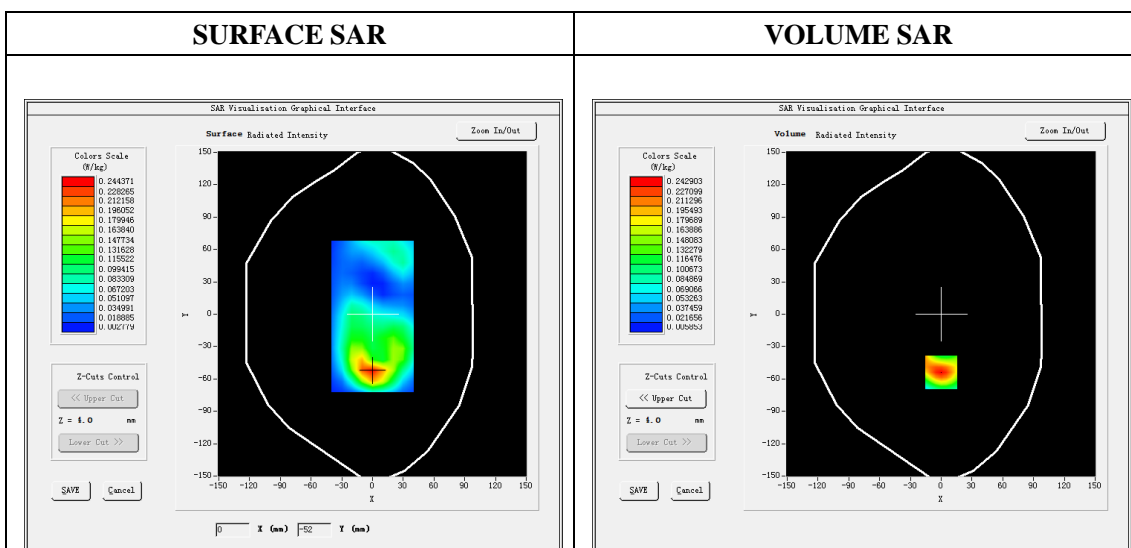

Maximum location: X=0.00, Y=-54.00
SAR Peak: 0.43 W/kg

SAR 10g (W/Kg)	0.113248
SAR 1g (W/Kg)	0.236918

Plot 6: GPRS1900, Back, High

Type: Phone measurement
 Date of measurement: 18/11/2015
 Measurement duration: 6 minutes 40 seconds
 Mobile Phone IMEI number: --

A. Experimental conditions.

Area Scan	dx=8mm dy=8mm
ZoomScan	5x5x7,dx=8mm dy=8mm dz=5mm
Phantom	Validation plane
Device Position	Back
Band	GPRS1900
Channels	810
Signal	GPRS (Duty cycle: 1:2.67)

B. SAR Measurement Results

E-Field Probe	SATIMO SN_04/13_EP166
Frequency (MHz)	1909.8
Relative permittivity (real part)	53.14
Relative permittivity (imaginary part)	14.40
Conductivity (S/m)	1.52
Variation (%)	-4.02
ConvF:	5.43

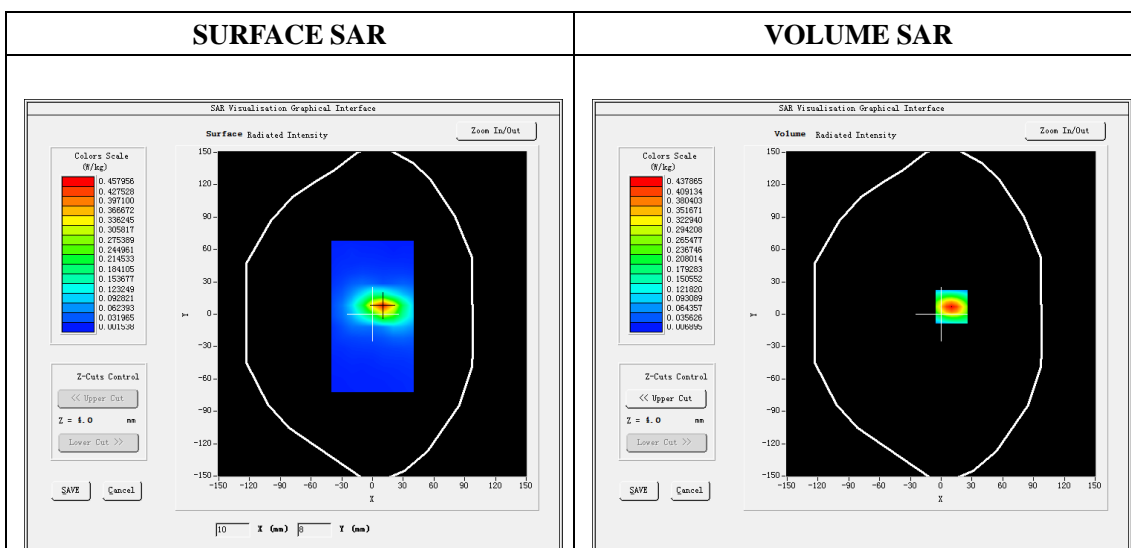

Maximum location: X=10.00, Y=7.00
 SAR Peak: 0.75 W/kg

SAR 10g (W/Kg)	0.182929
SAR 1g (W/Kg)	0.390427

Plot 7: WCDMA1900, Left Cheek, High

Type: Phone measurement

Date of measurement: 14/11/2015

Measurement duration: 7 minutes 11 seconds

Mobile Phone IMEI number: --

A. Experimental conditions.

Area Scan	dx=8mm dy=8mm
ZoomScan	5x5x7,dx=8mm dy=8mm dz=5mm
Phantom	Validation plane
Device Position	Left head
Band	Cheek
Channels	9538
Signal	WCDMA (Duty cycle: 1:1)

B. SAR Measurement Results

E-Field Probe	SATIMO SN_04/13_EP166
Frequency (MHz)	1907.6
Relative permittivity (real part)	39.85
Relative permittivity (imaginary)	13.17
Conductivity (S/m)	1.39
Variation (%)	-4.49
ConvF:	5.25

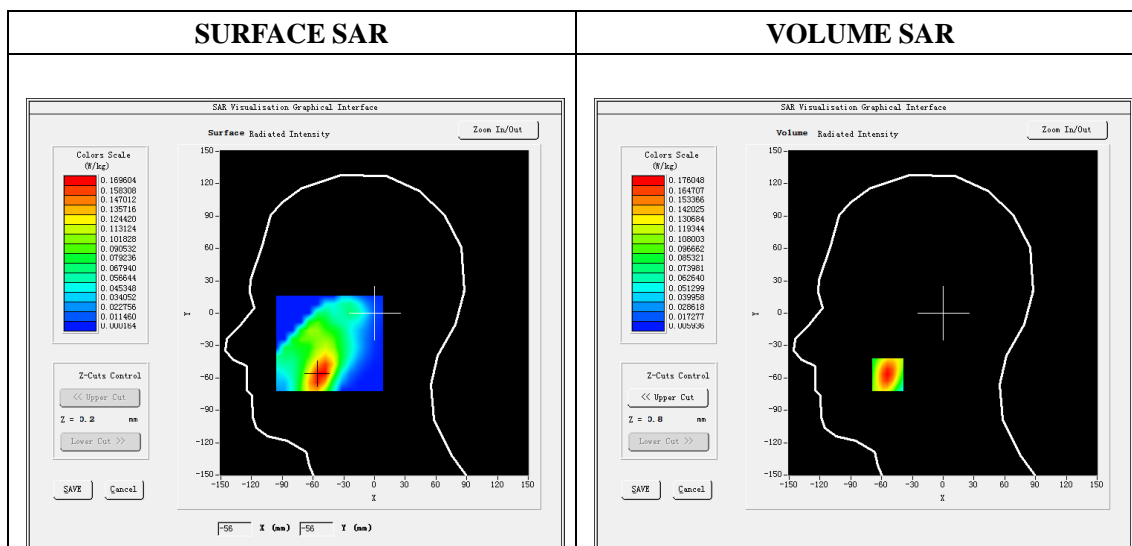

Maximum location: X=-54.00, Y=-57.00

SAR Peak: 0.28 W/kg

SAR 10g (W/Kg)	0.086993
SAR 1g (W/Kg)	0.162640

Plot 8: WCDMA1900, Face, High

Type: Phone measurement
 Date of measurement: 18/11/2015
 Measurement duration: 7 minutes 14 seconds
 Mobile Phone IMEI number: --

A. Experimental conditions.

Area Scan	dx=8mm dy=8mm
ZoomScan	5x5x7,dx=8mm dy=8mm dz=5mm
Phantom	Validation plane
Device Position	Face
Band	Band2_WCDMA1900
Channels	9538
Signal	WCDMA (Duty cycle: 1:1)

B. SAR Measurement Results

E-Field Probe	SATIMO SN_04/13_EP166
Frequency (MHz)	1907.6
Relative permittivity (real part)	53.14
Relative permittivity (imaginary)	14.40
Conductivity (S/m)	1.52
Variation (%)	-0.06
ConvF:	5.43

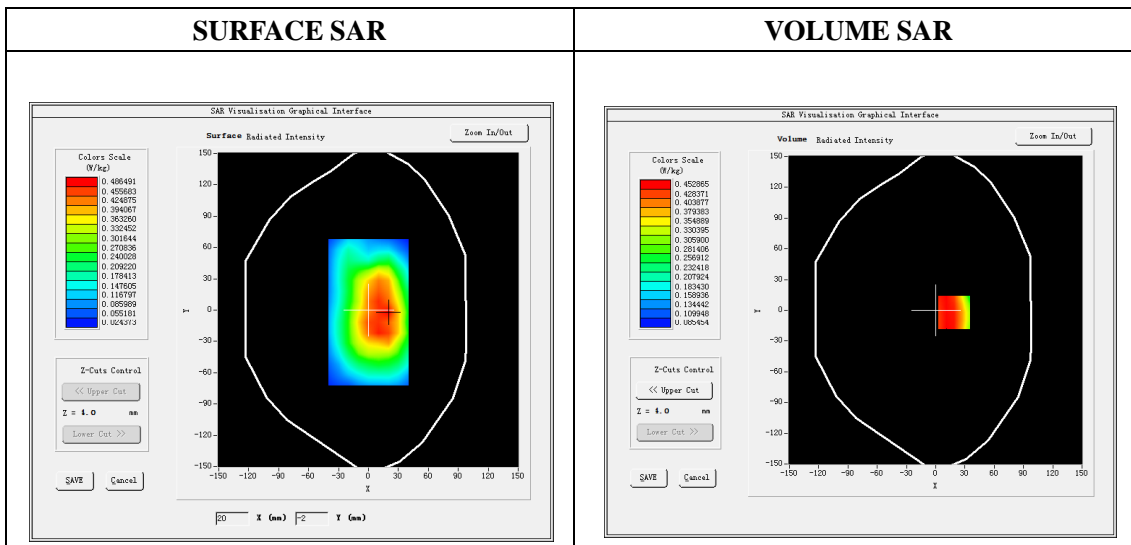

Maximum location: X=26.00, Y=-3.00
 SAR Peak: 0.466 W/kg

SAR 10g (W/Kg)	0.210781
SAR 1g (W/Kg)	0.401624

Plot 9: WCDMA1900, Edge C, High

Type: Phone measurement
 Date of measurement: 18/11/2015
 Measurement duration: 7 minutes 17 seconds
 Mobile Phone IMEI number: --

A. Experimental conditions.

Area Scan	dx=8mm dy=8mm
ZoomScan	5x5x7,dx=8mm dy=8mm dz=5mm
Phantom	Validation plane
Device Position	Edge C
Band	Band2_WCDMA1900
Channels	9538
Signal	WCDMA (Duty cycle: 1:1)

B. SAR Measurement Results

E-Field Probe	SATIMO SN_04/13_EP166
Frequency (MHz)	1907.6
Relative permittivity (real part)	53.14
Relative permittivity (imaginary)	14.40
Conductivity (S/m)	1.52
Variation (%)	-1.13
ConvF:	5.43

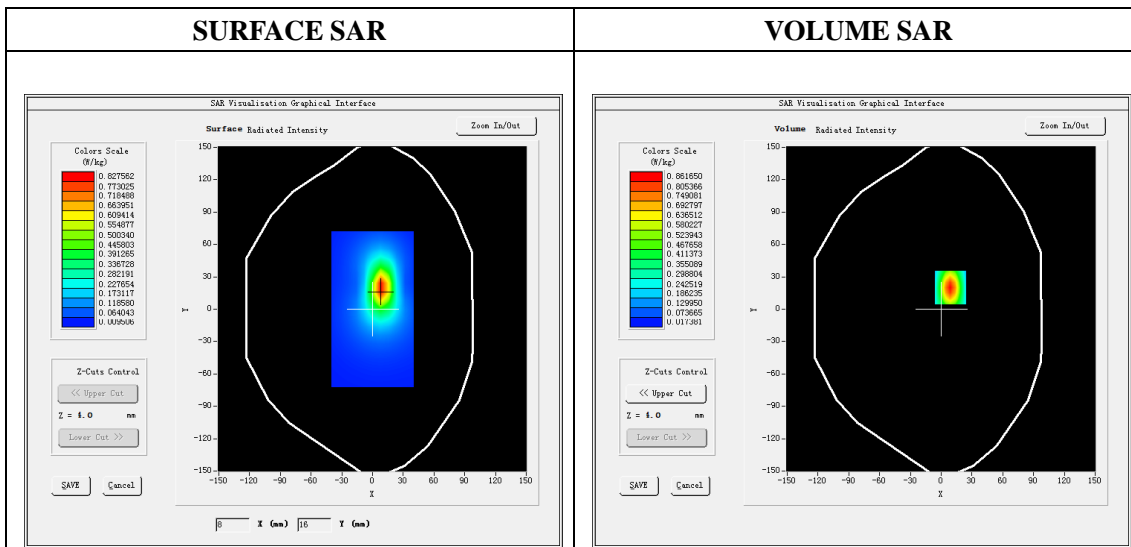

Maximum location: X=9.00, Y=20.00
 SAR Peak: 1.49 W/kg

SAR 10g (W/Kg)	0.364614
SAR 1g (W/Kg)	0.777709

Plot 10: WCDMA1700, Left Cheek, Low

Type: Phone measurement

Date of measurement: 23/09/2015

Measurement duration: 7 minutes 12 seconds

Mobile Phone IMEI number: --

A. Experimental conditions.

Area Scan	dx=8mm dy=8mm
ZoomScan	5x5x7,dx=8mm dy=8mm dz=5mm
Phantom	Validation plane
Device Position	Left head
Band	Cheek
Channels	1312
Signal	WCDMA (Duty cycle: 1:1)

B. SAR Measurement Results

E-Field Probe	SATIMO SN_04/13_EP166
Frequency (MHz)	1712.4
Relative permittivity (real part)	39.75
Relative permittivity (imaginary)	13.90
Conductivity (S/m)	1.39
Variation (%)	2.23
ConvF:	4.75

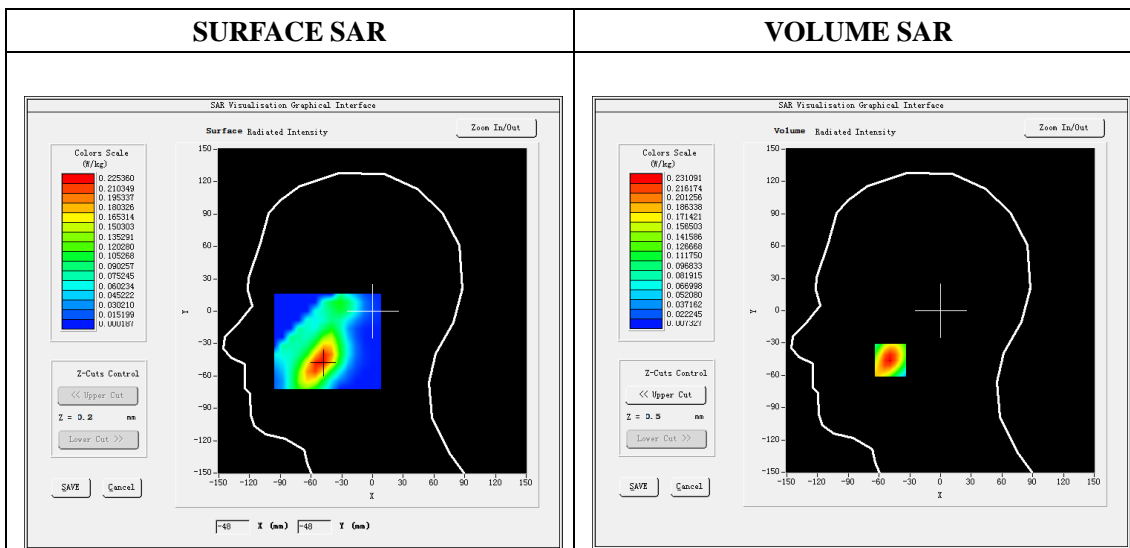

Maximum location: X=-49.00, Y=-46.00

SAR Peak: 0.35 W/kg

SAR 10g (W/Kg)	0.120095
SAR 1g (W/Kg)	0.214297

Plot 11: WCDMA1700, Back Upward(Body-worn, hotspot), Low

Type: Phone measurement

Date of measurement: 24/09/2015

Measurement duration: 7 minutes 13 seconds

Mobile Phone IMEI number: --

A. Experimental conditions.

Area Scan	dx=8mm dy=8mm
ZoomScan	5x5x7,dx=8mm dy=8mm dz=5mm
Phantom	Validation plane
Device Position	Back
Band	Band2_WCDMA1700
Channels	1312
Signal	WCDMA (Duty cycle: 1:1)

B. SAR Measurement Results

E-Field Probe	SATIMO SN_04/13_EP166
Frequency (MHz)	1712.4
Relative permittivity (real part)	53.37
Relative permittivity (imaginary)	15.00
Conductivity (S/m)	1.50
Variation (%)	-0.28
ConvF:	4.96

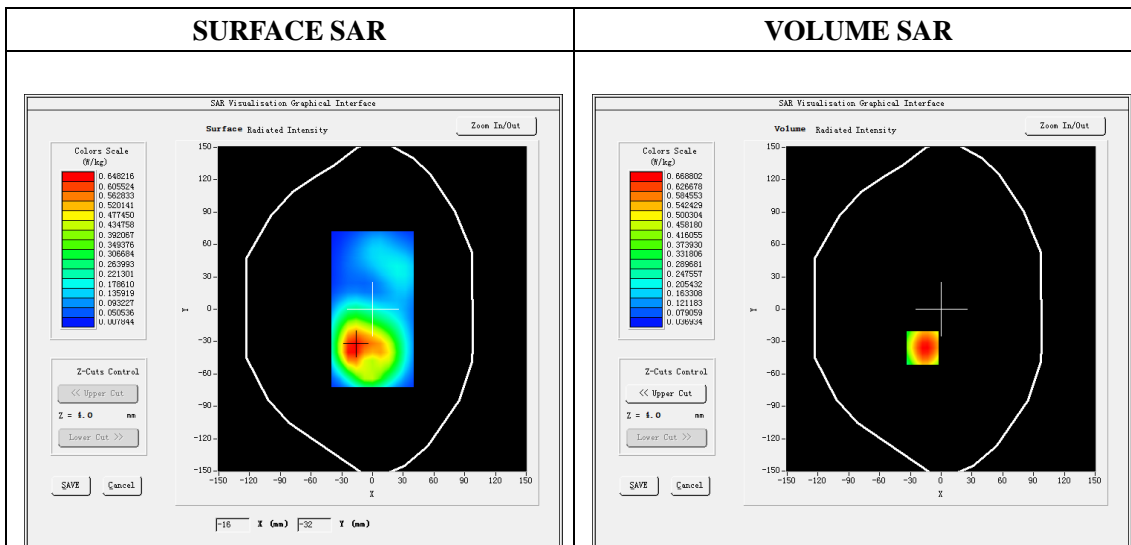

Maximum location: X=-18.00, Y=-36.00
SAR Peak: 1.11 W/kg

SAR 10g (W/Kg)	0.351394
SAR 1g (W/Kg)	0.637797

Plot 12: WCDMA850, Left Cheek, Low

Type: Phone measurement

Date of measurement: 13/11/2015

Measurement duration: 6 minutes 33 seconds

Mobile Phone IMEI number: --

A. Experimental conditions.

Area Scan	dx=8mm dy=8mm
ZoomScan	5x5x7,dx=8mm dy=8mm dz=5mm
Phantom	Left head
Device Position	Cheek
Band	Band5_WCDMA850
Channels	4132
Signal	WCDMA (Duty cycle: 1:1)

B. SAR Measurement Results

E-Field Probe	SATIMO SN_04/13_EP166
Frequency (MHz)	826.4
Relative permittivity (real part)	41.36
Relative permittivity (imaginary part)	18.97
Conductivity (S/m)	0.88
Variation (%)	2.62
ConvF:	5.69

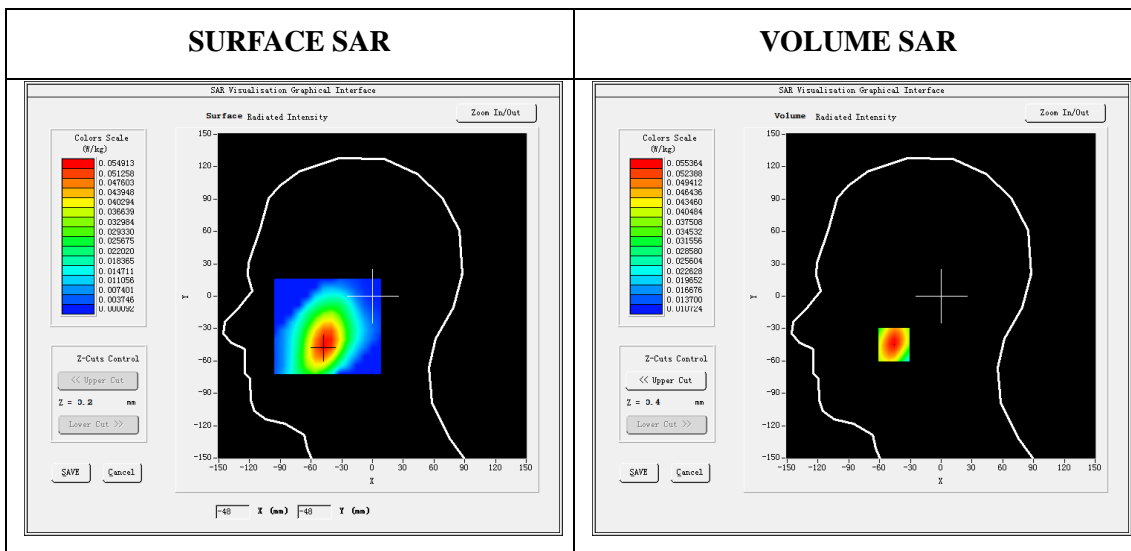

Maximum location: X=-46.00, Y=-45.00

SAR Peak: 0.07 W/kg

SAR 10g (W/Kg)	0.039954
SAR 1g (W/Kg)	0.052887

Plot 13: WCDMA850, Back Upward(Body-worn, hotspot), Low

Type: Phone measurement
 Date of measurement:17/11/2015
 Measurement duration: 7 minutes 19 seconds
 Mobile Phone IMEI number: --

A. Experimental conditions.

Area Scan	dx=8mm dy=8mm
ZoomScan	5x5x7,dx=8mm dy=8mm dz=5mm
Phantom	Validation plane
Device Position	Back
Band	Band5_WCDMA850
Channels	4132
Signal	WCDMA (Duty cycle: 1:1)

B. SAR Measurement Results

E-Field Probe	SATIMO SN_04/13_EP166
Frequency (MHz)	826.4
Relative permittivity (real part)	55.32
Relative permittivity (imaginary part)	20.12
Conductivity (S/m)	0.95
Variation (%)	0.07
ConvF:	5.82

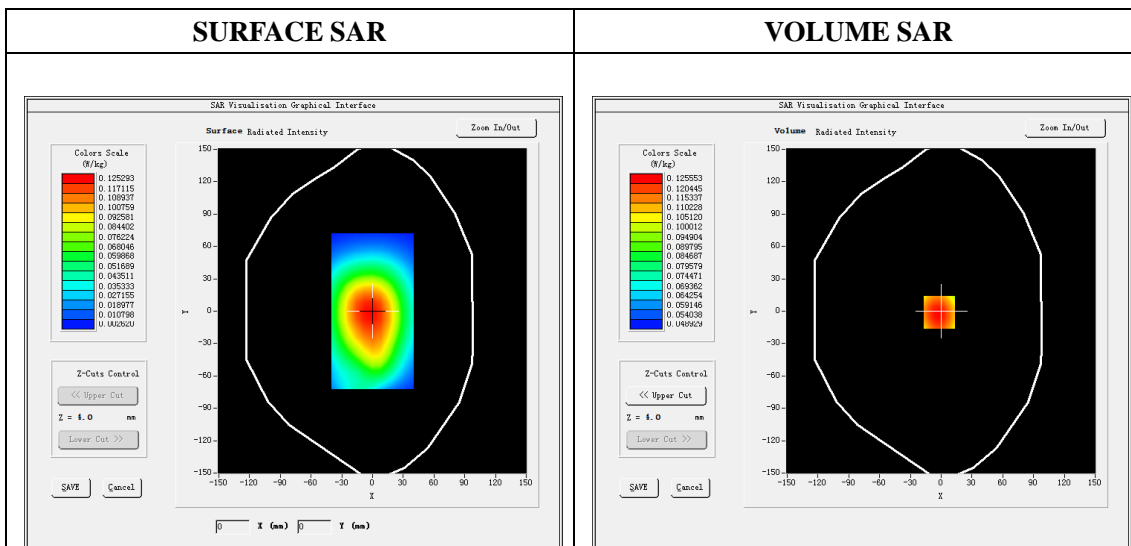

**Maximum location: X=-2.00, Y=-1.00
 SAR Peak: 0.15 W/kg**

SAR 10g (W/Kg)	0.094054
SAR 1g (W/Kg)	0.121394

Plot 14: LTE Band 2,20MHz, Right Cheek, High

Type: Phone measurement

Date of measurement: 14/11/2015

Measurement duration: 7 minutes 19 seconds

Mobile Phone IMEI number: --

A. Experimental conditions.

Area Scan	dx=8mm dy=8mm
ZoomScan	5x5x7,dx=8mm dy=8mm dz=5mm
Phantom	Validation plane
Device Position	Right Cheek
Band	LTE Band2
Channels	19100
Signal	Duty cycle: 1:1

B. SAR Measurement Results

E-Field Probe	SATIMO SN_04/13_EP166
Frequency (MHz)	1900
Relative permittivity (real part)	39.85
Relative permittivity (imaginary)	13.17
Conductivity (S/m)	1.39
Variation (%)	-4.43
ConvF:	5.25

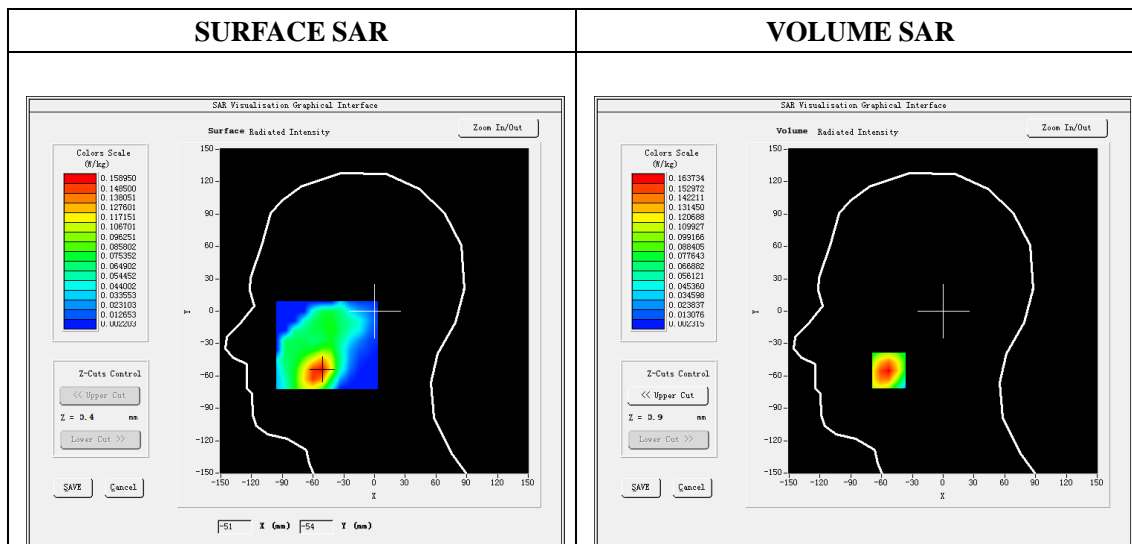

Maximum location: X=-53.00, Y=-55.00

SAR Peak: 0.25W/kg

SAR 10g (W/Kg)	0.084120
SAR 1g (W/Kg)	0.154375

Plot 15: LTE Band2, 20MHz, Back upward , High

Type: Phone measurement

Date of measurement: 18/11/2015

Measurement duration: 7 minutes 13 seconds

Mobile Phone IMEI number: --

A. Experimental conditions.

Area Scan	dx=8mm dy=8mm
ZoomScan	5x5x7,dx=8mm dy=8mm dz=5mm
Phantom	Validation plane
Device Position	Back
Band	LTE Band2
Channels	19100
Signal	Duty cycle: 1:1

B. SAR Measurement Results

E-Field Probe	SATIMO SN_04/13_EP166
Frequency (MHz)	1990
Relative permittivity (real part)	53.14
Relative permittivity (imaginary)	14.40
Conductivity (S/m)	1.52
Variation (%)	-2.74
ConvF:	5.43

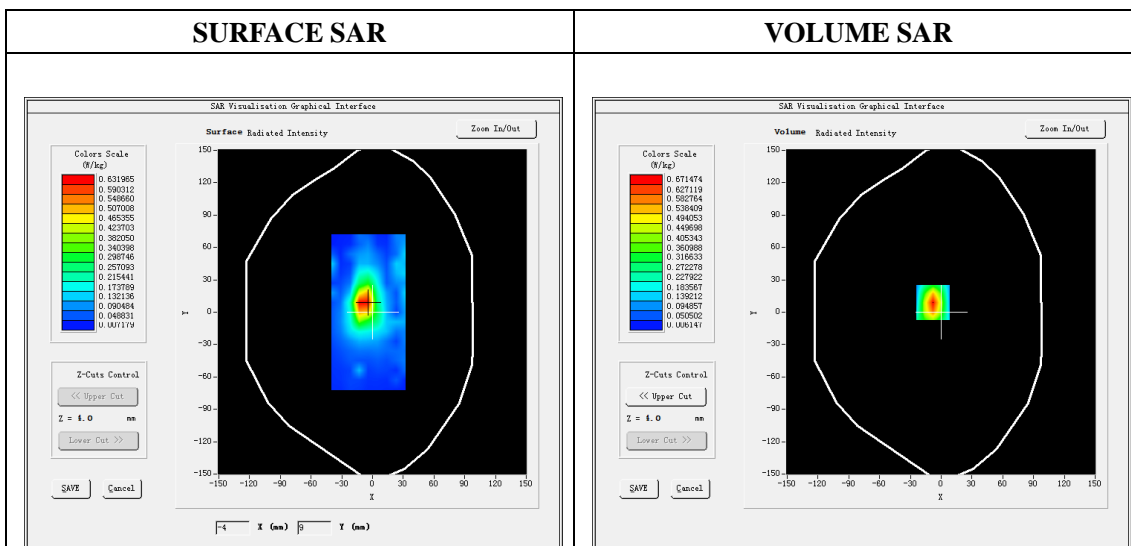

Maximum location: X=-9.00, Y=12.00
SAR Peak: 0.63 W/kg

SAR 10g (W/Kg)	0.207595
SAR 1g (W/Kg)	0.406892

Plot 16: LTE Band2, 20MHz, Edge C , High

Type: Phone measurement

Date of measurement: 18/11/2015

Measurement duration: 7 minutes 13 seconds

Mobile Phone IMEI number: --

A. Experimental conditions.

Area Scan	dx=8mm dy=8mm
ZoomScan	5x5x7,dx=8mm dy=8mm dz=5mm
Phantom	Validation plane
Device Position	Edge C
Band	LTE Band2
Channels	19100
Signal	Duty cycle: 1:1

B. SAR Measurement Results

E-Field Probe	SATIMO SN_04/13_EP166
Frequency (MHz)	1990
Relative permittivity (real part)	53.14
Relative permittivity (imaginary)	14.40
Conductivity (S/m)	1.52
Variation (%)	-4.71
ConvF:	5.43

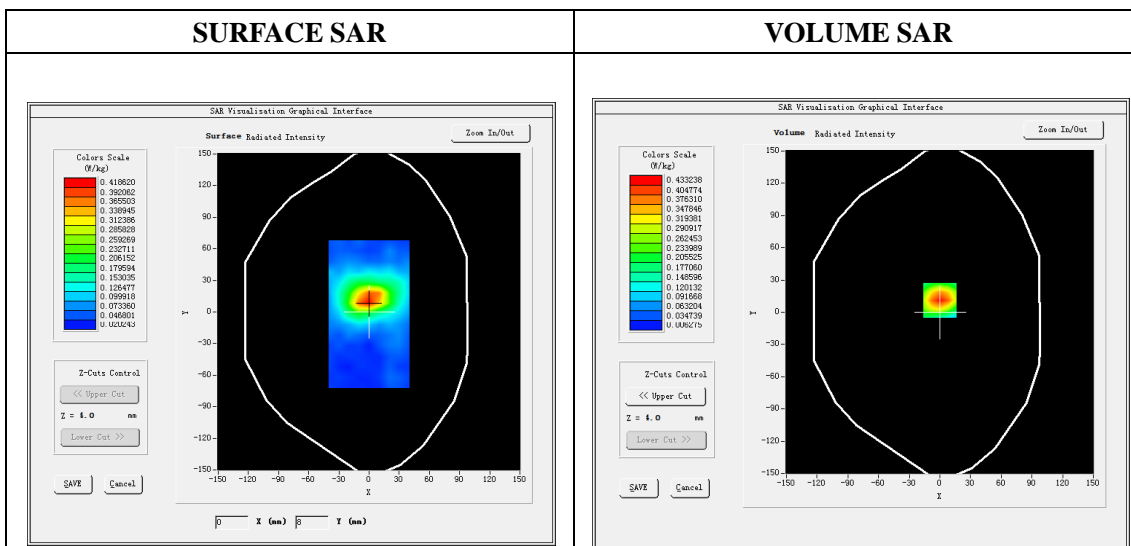

Maximum location: X=-8.00, Y=9.00
SAR Peak: 1.22 W/kg

SAR 10g (W/Kg)	0.279316
SAR 1g (W/Kg)	0.617861

Plot 17: LTE Band4, 20MHz, Left Cheek, Middle

Type: Phone measurement

Date of measurement: 14/11/2015

Measurement duration: 7 minutes 31 seconds

Mobile Phone IMEI number: --

A. Experimental conditions.

Area Scan	dx=8mm dy=8mm
ZoomScan	5x5x7,dx=8mm dy=8mm dz=5mm
Phantom	Validation plane
Device Position	Left head
Band	Cheek
Channels	20175
Signal	LTE (Duty cycle: 1:1)

B. SAR Measurement Results

E-Field Probe	SATIMO SN_04/13_EP166
Frequency (MHz)	1732.5
Relative permittivity (real part)	39.75
Relative permittivity (imaginary)	13.90
Conductivity (S/m)	1.39
Variation (%)	-4.66
ConvF:	4.75

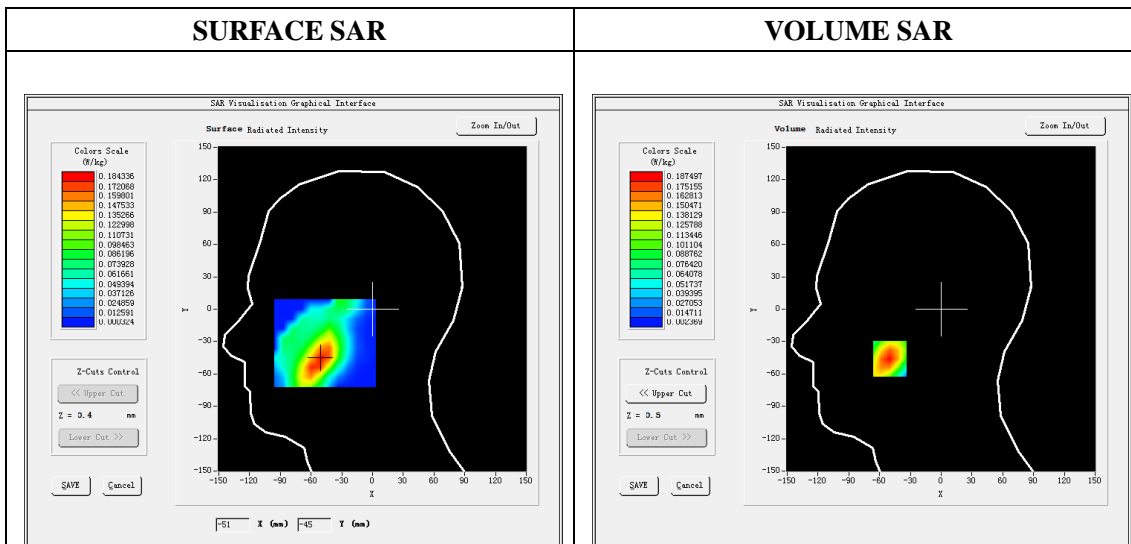

Maximum location: X=-50.00, Y=-46.00

SAR 10g (W/Kg)	0.097237
SAR 1g (W/Kg)	0.175910

Plot 18: LTE Band4, 20MHz, Back Upward(Body-worn, hotspot), Middle

Type: Phone measurement

Date of measurement: 17/7/2015

Measurement duration: 7 minutes 37 seconds

Mobile Phone IMEI number: --

A. Experimental conditions.

Area Scan	dx=8mm dy=8mm
ZoomScan	5x5x7,dx=8mm dy=8mm dz=5mm
Phantom	Validation plane
Device Position	Back
Band	LTE Band 4
Channels	20175
Signal	LTE (Duty cycle: 1:1)

B. SAR Measurement Results

E-Field Probe	SATIMO SN_04/13_EP166
Frequency (MHz)	1732.5
Relative permittivity (real part)	53.37
Relative permittivity (imaginary)	15.00
Conductivity (S/m)	1.50
Variation (%)	-1.08
ConvF:	4.96

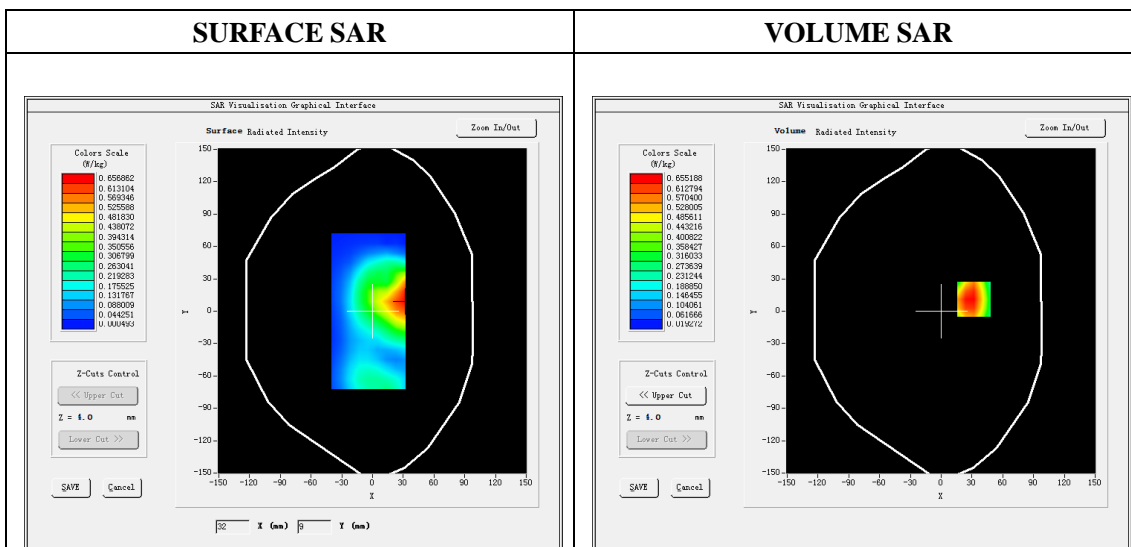

**Maximum location: X=32.00, Y=11.00
SAR Peak: 1.04 W/kg**

SAR 10g (W/Kg)	0.035955
SAR 1g (W/Kg)	0.633356

Plot 19: LTE Band 7, 20MHz, Right Cheek, Middle

Type: Phone measurement

Date of measurement: 16/11/2015

Measurement duration: 6 minutes 45 seconds

Mobile Phone IMEI number: --

A. Experimental conditions.

Area Scan	dx=8mm dy=8mm
ZoomScan	5x5x7,dx=8mm dy=8mm dz=5mm
Phantom	Right head
Device Position	Cheek
Band	LTE Band 7
Channels	21100
Signal	LTE(Duty cycle: 1:1)

B. SAR Measurement Results

E-Field Probe	SATIMO SN_04/13_EP166
Frequency (MHz)	2535
Relative permittivity (real part)	38.89
Relative permittivity (imaginary part)	13.36
Conductivity (S/m)	1.93
Variation (%)	-2.26
ConvF:	5.08

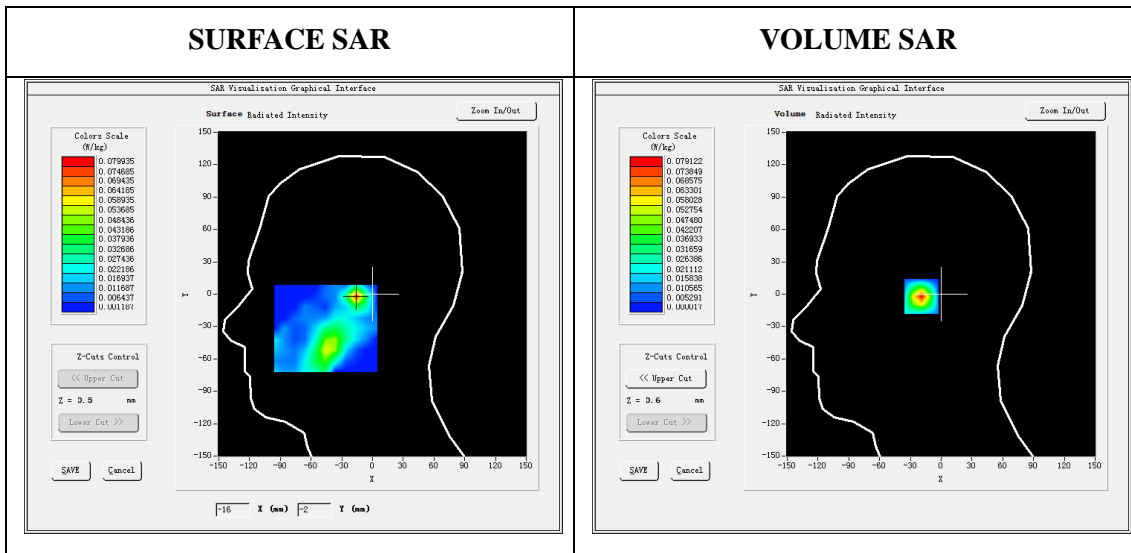

Maximum location: X=-16.00, Y=-2.00

SAR Peak: 0.16 W/kg

SAR 10g (W/Kg)	0.026054
SAR 1g (W/Kg)	0.072406

Plot 20: LTE Band 7, 20MHz, Back, Middle

Type: Phone measurement
 Date of measurement: 19/11/2015
 Measurement duration: 7 minutes 32 seconds
 Mobile Phone IMEI number: --

A. Experimental conditions.

Area Scan	dx=8mm dy=8mm
ZoomScan	5x5x7, dx=8mm dy=8mm dz=5mm
Phantom	Validation plane
Device Position	Back
Band	LTE Band 7
Channels	21100
Signal	LTE (Duty cycle: 1:1)

B. SAR Measurement Results

E-Field Probe	SATIMO SN_04/13_EP166
Frequency (MHz)	2535
Relative permittivity (real part)	52.56
Relative permittivity (imaginary part)	14.88
Conductivity (S/m)	2.15
Variation (%)	-1.67
ConvF:	5.22

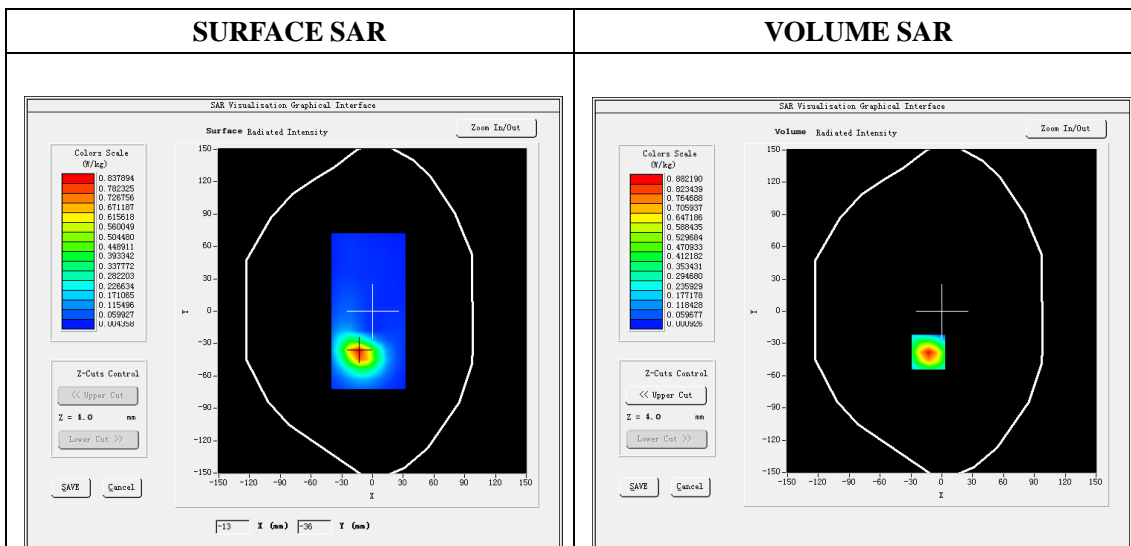

Maximum location: X=-13.00, Y=-38.00
 SAR Peak: 1.72 W/kg

SAR 10g (W/Kg)	0.345381
SAR 1g (W/Kg)	0.821597

Plot 21: LTE Band 7, 20MHz, Edge C, Middle

Type: Phone measurement

Date of measurement: 19/11/2015

Measurement duration: 7 minutes 49 seconds

Mobile Phone IMEI number: --

A. Experimental conditions.

Area Scan	dx=8mm dy=8mm
ZoomScan	5x5x7, dx=8mm dy=8mm dz=5mm
Phantom	Validation plane
Device Position	Edge C
Band	LTE Band 7
Channels	21100
Signal	LTE (Duty cycle: 1:1)

B. SAR Measurement Results

E-Field Probe	SATIMO SN_04/13_EP166
Frequency (MHz)	2535
Relative permittivity (real part)	52.56
Relative permittivity (imaginary part)	14.88
Conductivity (S/m)	2.15
Variation (%)	-2.03
ConvF:	5.22

SURFACE SAR

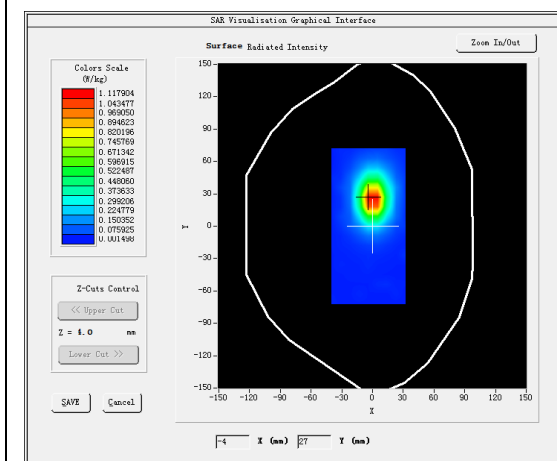

VOLUME SAR

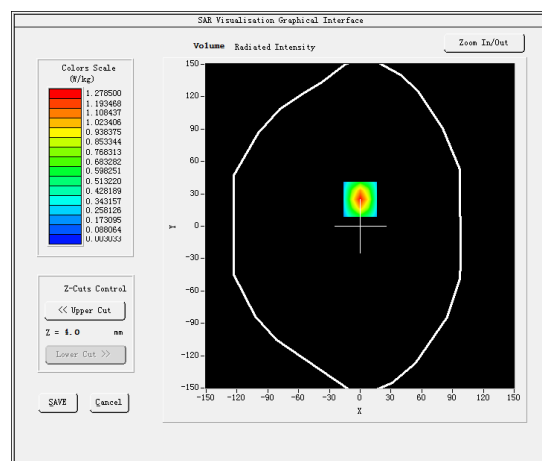

Maximum location: X=0.00, Y=25.00

SAR Peak: 2.47 W/kg

SAR 10g (W/Kg)	0.490544
SAR 1g (W/Kg)	1.080030

Plot 22: LTE Band 17, 10MHz, Right Cheek, Middle

Type: Phone measurement
 Date of measurement: 13/11/2015
 Measurement duration: 6 minutes 43 seconds
 Mobile Phone IMEI number: --

A. Experimental conditions.

Area Scan	dx=8mm dy=8mm
ZoomScan	5x5x7,dx=8mm dy=8mm dz=5mm
Phantom	Right head
Device Position	Cheek
Band	LTE Band 17
Channels	23790
Signal	LTE(Duty cycle: 1:1)

B. SAR Measurement Results

E-Field Probe	SATIMO SN_09/13_EP169
Frequency (MHz)	710
Relative permittivity (real part)	41.71
Relative permittivity (imaginary part)	21.12
Conductivity (S/m)	0.88
Variation (%)	4.14
ConvF:	5.26

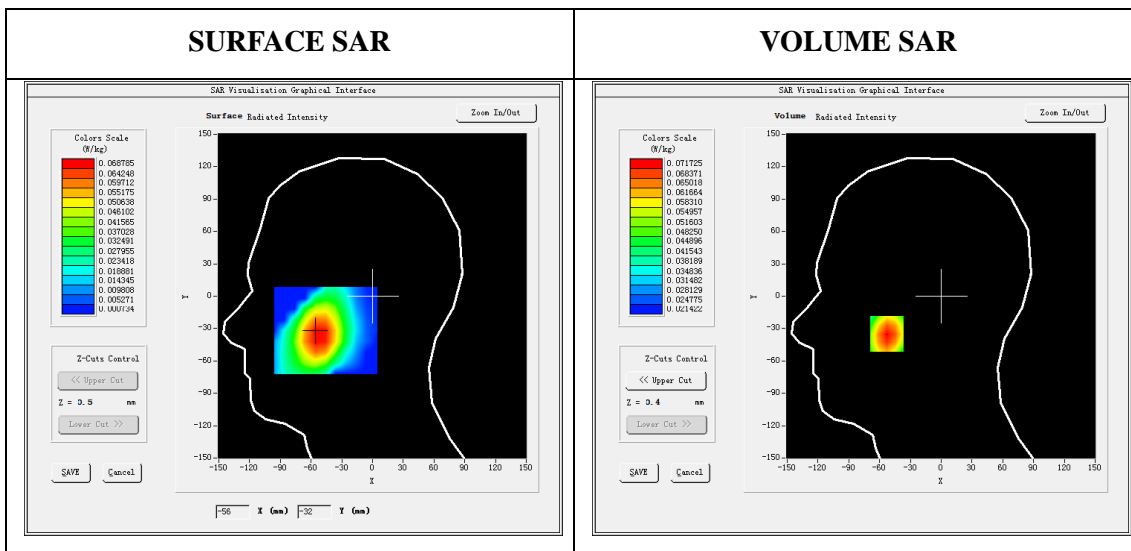

Maximum location: X=-53.00, Y=-35.00

SAR 10g (W/Kg)	0.059402
SAR 1g (W/Kg)	0.073505