



Part 15C

TEST REPORT

Product Name WCDMA/GSM Dual band mobile phone

Model W716S

Brand Name Haier

FCC ID SG71408W716S

Applicant Haier Telecom (Qingdao) Co., Ltd.

Manufacturer Haier Telecom (Qingdao) Co., Ltd.

Date of issue August 14, 2014

TA Technology (Shanghai) Co., Ltd.

TA Technology (Shanghai) Co., Ltd.
Test Report

Report No.: RXA1407-0191RF03

Page 2of 93

GENERAL SUMMARY

Reference Standard(s)	<p>FCC CFR47 Part 15C (2013) Radio Frequency Devices</p> <p>15.205 Restricted bands of operation;</p> <p>15.207 Conducted limits;</p> <p>15.209 Radiated emission limits; general requirements;</p> <p>15.247 Operation within the bands 902-928 MHz,2400-2483.5 MHz, and 5725-5850MHz.</p> <p>ANSI C63.4 Methods of Measurement of Radio-Noise Emission from Low-Voltage Electrical and Electronic Equipment in the Range of 9 KHz to 40GHz. (2009)</p> <p>DA00-705 Filing and Frequency Measurement Guidelines For Frequency Hopping Spread Spectrum System.(2000)</p>
Conclusion	<p>This portable wireless equipment has been measured in all cases requested by the relevant standards. Test results in Chapter 2 of this test report are below limits specified in the relevant standards.</p> <p>General Judgment: Pass</p>
Comment	<p>The test result only responds to the measured sample.</p>

Approved by Weizhong Yang
Weizhong Yang
Director

Revised by Lingling Kang
Lingling Kang
RF Manager

Performed by Yu Wang
Yu Wang
RF Engineer

TA Technology (Shanghai) Co., Ltd.
Test Report

TABLE OF CONTENT

1. General Information	4
1.1. Notes of the test report.....	4
1.2. Testing laboratory	5
1.3. Applicant Information	5
1.4. Manufacturer Information.....	5
1.5. Information of EUT	6
1.6. Test Date	7
2. Information about the FHSS characteristics.....	8
2.1. Pseudorandom Frequency Hopping Sequence	8
2.2. Equal Hopping Frequency Use	9
2.3. System Receiver Input Bandwidth	9
3. Test Information	10
3.1. Test Mode	10
3.2. Summary of test results	10
3.3. Peak Power Output –Conducted.....	11
3.4. Occupied Bandwidth (20dB)	13
3.5. Frequency Separation.....	20
3.6. Time of Occupancy (Dwell Time).....	27
3.7. Band Edge Compliance	31
3.8. Spurious Radiated Emissions in the Restricted Band	38
3.9. Number of hopping Frequency.....	44
3.10. Spurious RF Conducted Emissions.....	48
3.11. Radiates Emission.....	56
3.12. Conducted Emission.....	83
4. Main Test Instruments.....	88
ANNEX A: EUT Appearance and Test Setup	89
A.1 EUT Appearance.....	89
A.2 Test Setup	92

TA Technology (Shanghai) Co., Ltd. Test Report

Report No.: RXA1407-0191RF03

Page 4 of 93

1. General Information

1.1. Notes of the test report

TA Technology (Shanghai) Co., Ltd. has obtained the accreditation of China National Accreditation Service for Conformity Assessment (CNAS), and accreditation number: L2264.

TA Technology (Shanghai) Co., Ltd. has been listed on the US Federal Communications Commission list of test facilities recognized to perform electromagnetic emissions measurements. The site recognition number is 428261.

TA Technology (Shanghai) Co., Ltd. has been listed by industry Canada to perform electromagnetic emission measurement. The site recognition number is 8510A.

TA Technology (Shanghai) Co., Ltd. guarantees the reliability of the data presented in this test report, which is the results of measurements and tests performed for the items under test on the date and under the conditions stated in this test report and is based on the knowledge and technical facilities available at TA Technology (Shanghai) Co., Ltd. at the time of execution of the test.

TA Technology (Shanghai) Co., Ltd. is liable to the client for the maintenance by its personnel of the confidentiality of all information related to the items under test and the results of the test. The sample under test was selected by the Client. This report only refers to the item that has undergone the test.

This report alone does not constitute or imply by its own an approval of the product by the certification Bodies or competent Authorities. This report cannot be used partially or in full for publicity and/or promotional purposes without previous written approval of **TA Technology (Shanghai) Co., Ltd.** and the Accreditation Bodies, if it applies.

If the electronic report is inconsistent with the printed one, it should be subject to the latter.

TA Technology (Shanghai) Co., Ltd. Test Report

Report No.: RXA1407-0191RF03

Page 5 of 93

1.2. Testing laboratory

Company: TA Technology (Shanghai) Co., Ltd.
Address: No.145, Jintang Rd, Tangzhen Industry Park, Pudong
City: Shanghai
Post code: 201201
Country: P. R. China
Contact: Yang Weizhong
Telephone: +86-021-50791141/2/3
Fax: +86-021-50791141/2/3-8000
Website: <http://www.ta-shanghai.com>
E-mail: yangweizhong@ta-shanghai.com

1.3. Applicant Information

Company: Haier Telecom (Qingdao) Co., Ltd.
Address: No1. Haier Road , Hi-tech Zone,
Qingdao/China

1.4. Manufacturer Information

Company: Haier Telecom (Qingdao) Co., Ltd.
Address: No1. Haier Road , Hi-tech Zone,
Qingdao/China

TA Technology (Shanghai) Co., Ltd.

Test Report

Report No.: RXA1407-0191RF03

Page 6 of 93

1.5. Information of EUT

General information

IMEI:	862295021475693		
Hardware Version:	H01		
Software Version:	HW-W716S-H01-S001-VE		
Antenna Type:	Internal Antenna		
Device Operating Configurations:			
Test Mode	Basic Rate	Enhanced Data Rate(EDR)	
Modulation Type:	Frequency Hopping Spread Spectrum (FHSS)		
	GFSK	$\pi/4$ DQPSK	8DQPSK
Packet Type:(Maximum Payload)	DH5	2DH5	3DH5
Max. Conducted Power	3.04 dBm		
Power Supply:	Battery or Adapter		
Operating Frequency Range(s)	2402 ~ 2480MHz		
Tested Frequency Range(s)	2400 ~ 2483.5 MHz		

TA Technology (Shanghai) Co., Ltd. Test Report

Report No.: RXA1407-0191RF03

Page 7 of 93

Auxiliary equipment details

Name	Model	Manufacturer	Capacity	S/N
Battery	H11277	Zhongshan TIANMAO Battery Co.,Ltd	1400mAh	EB094300000E0000315T

Name	Model	Manufacturer	S/N
Adapter	LSD-D05I055	LISHUNDA Electronics CO.LTD	/
Earphone 1	MY-M6295	ZheJiang MEEYON technology Co.,Ltd	/
Earphone 2	PY-1353001-01KB42	HETONG	/

1.6. Test Date

The test is performed from August 6, 2014 to August 12, 2014.

2. Information about the FHSS characteristics

2.1. Pseudorandom Frequency Hopping Sequence

Frequency Hopping Systems. A spread spectrum system in which the carrier is modulated with the coded information in a conventional manner causing a conventional spreading of the RF energy about the frequency carrier. The frequency of the carrier is not fixed but changes at fixed intervals under the direction of a coded sequence. The wide RF bandwidth needed by such a system is not required by spreading of the RF energy about the carrier but rather to accommodate the range of frequencies to which the carrier frequency can hop. The test of a frequency hopping system is that the near term distribution of hops appears random, the long term distribution appears evenly distributed over the hop set, and sequential hops are randomly distributed in both direction and magnitude of change in the hop set.

The selection scheme chooses a segment of 32 hop frequencies spanning about 64 MHz and visits these hops in a pseudo-random order. Next, a different 32-hop segment is chosen, etc. In the page, master page response, slave page response, page scan, inquiry, inquiry response and inquiry scan hopping sequences, the same 32-hop segment is used all the time (the segment is selected by the address; different devices will have different paging segments).

When the basic channel hopping sequence is selected, the output constitutes a pseudo-random sequence that slides through the 79 hops. The principle is depicted in the figure below.

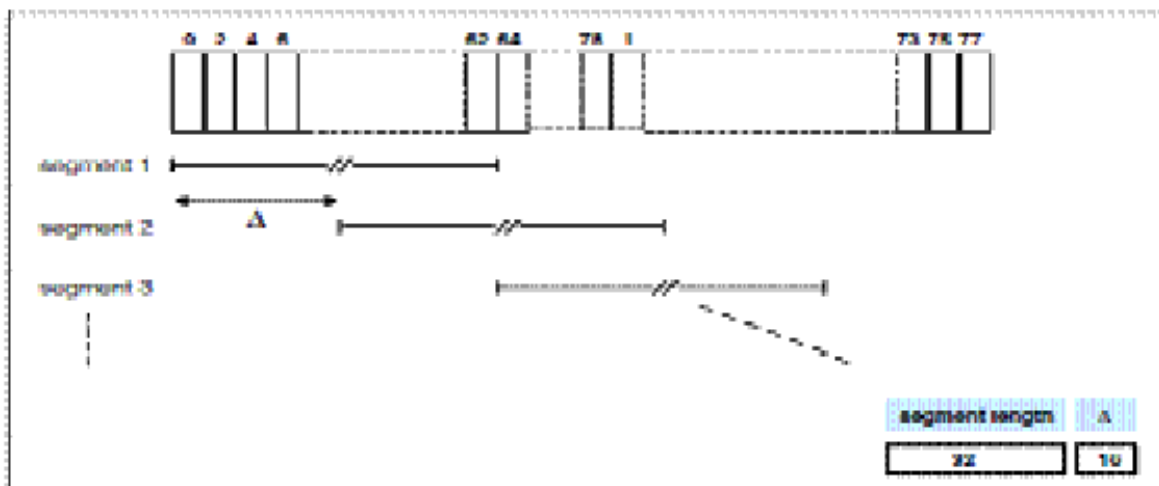

Hop selection scheme in CONNECTION state.

Pseudorandom Frequency Hopping Sequence Table as below:

Channel: 08, 24, 40, 56, 40, 56, 72, 09, 01, 09, 33, 41, 33, 41, 65, 73, 53, 69, 06, 22, 04, 20, 36, 52, 38, 46, 70, 78, 68, 76, 21, 29, 10, 26, 42, 58, 44, 60, 76, 13, 03, 11, 35, 43, 37, 45, 69, 77, 55, 71, 08, 24, 08, 24, 40, 56, 40, 48, 72, 01, 72, 01, 25, 33, 12, 28, 44, 60, 42, 58, 74, 11, 05, 13, 37, 45, etc.

Each frequency used equally on the average by each transmitter.

The system receiver have input bandwidths that match the hopping channel bandwidths of their corresponding transmitters and shift frequencies in synchronization with the transmitted signals.

TA Technology (Shanghai) Co., Ltd.

Test Report

2.2. Equal Hopping Frequency Use

All Bluetooth units participating in the Pico net are time and hop-synchronized to the channel. Each new transmission event begins on the next channel in the hopping sequence after the final channel used in the previous transmission event.

2.3. System Receiver Input Bandwidth

Each channel bandwidth is 1MHz. The system receivers have input bandwidths that match the hopping channel bandwidths of their corresponding transmitters and shift frequencies in synchronization with the transmitted signals.

TA Technology (Shanghai) Co., Ltd.

Test Report

Report No.: RXA1407-0191RF03

Page 10 of 93

3. Test Information

3.1. Test Mode

During the process of the testing, The EUT is controlled by the Base Station Simulator to ensure max power transmission and proper modulation.

EUT is stand-up position (Z axis), lie-down position (X, Y axis). The worst emission was found in stand-up position (Z axis) and the worst case was recorded.

In order to find the worst case condition, Pre-tests are needed at the presence of different data rate declared in basic standard IEEE802.11.

Then this mode was measured in the following mode: EUT with cradle and EUT without cradle. The worst emission was found in EUT with cradle mode and the worst case was recorded.

Test Modes		
Band	Radiated Test Cases	Conducted Test Cases
BT	3DH5 8DQPSK(Channel 0/39/78)	DH5 GFSK(Channel 0/39/78) 2DH5 $\pi/4$ -DQPSK(Channel 0/39/78) 3DH5 8DQPSK(Channel 0/39/78)

Note: The maximum RF output power levels are 3DH5 for 8DQPSK modulation, For RSE and CSE, only the maximum RF output power is chosen.

3.2. Summary of test results

Number	Summary of measurements of results	Clause in FCC rules	Verdict
1	Peak Power Output -Conducted	15.247(b)(1)	PASS
2	Occupied Bandwidth (20dB)	15.247(a)(1)	PASS
3	Frequency Separation	15.247(a)(1)	PASS
4	Time of Occupancy (Dwell Time)	15.247(a)(1)(iii)	PASS
5	Band Edge Compliance	15.247(d)	PASS
6	Spurious Radiated Emissions in the restricted band	15.247(d),15.205,15.209	PASS
7	Number of Hopping Frequency	15.247(a)(1)(iii)	PASS
8	Spurious RF Conducted Emissions	15.247(d)	PASS
9	Radiates Emission	15.247(d),15.205,15.209	PASS
10	AC Power Line Conducted Emission	15.207	PASS

TA Technology (Shanghai) Co., Ltd.

Test Report

Report No.: RXA1407-0191RF03

Page 11 of 93

3.3. Peak Power Output –Conducted

Ambient condition

Temperature	Relative humidity	Pressure
23°C ~25°C	45%~50%	101.5kPa

Methods of Measurement

During the process of the testing, The EUT was connected to the spectrum analyzer and Bluetooth test set via a power splitter with a known loss. The EUT is controlled by the Bluetooth test set to ensure max power transmission with proper modulation. The peak detector is used. RBW is set to 2 MHz; VBW is set to 6 MHz. These measurements have been tested at following channels: 0, 39, and 78.

Test Setup

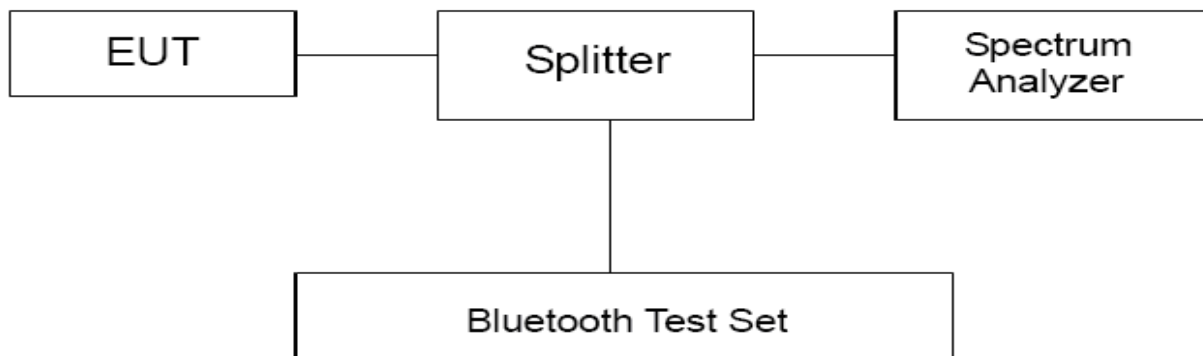

Limits

Rule Part 15.247 (b) (1) specifies that " For frequency hopping systems operating in the 2400–2483.5 MHz band employing at least 75 non-overlapping hopping channels, and all frequency hopping systems in the 5725–5850 MHz band: 1 watt. For all other frequency hopping systems in the 2400–2483.5 MHz band: 0.125 watts."

Peak Output Power	≤ 0.125W (21dBm)
-------------------	------------------

Measurement Uncertainty

The assessed measurement uncertainty to ensure 95% confidence level for the normal distribution is with the coverage factor $k = 2$, $U = 0.44$ dB.

TA Technology (Shanghai) Co., Ltd.
Test Report

Report No.: RXA1407-0191RF03

Page 12 of 93

Test Results

Channel	Frequency (MHz)	Peak Output Power (dBm)			Conclusion
		DH5	2DH5	3DH5	
0	2402	2.02	1.78	1.55	PASS
39	2441	2.67	2.15	2.10	PASS
78	2480	3.04	2.13	2.05	PASS

Note: The measured power density (dBm) has the offset with cable loss already.

TA Technology (Shanghai) Co., Ltd.

Test Report

Report No.: RXA1407-0191RF03

Page 13 of 93

3.4. Occupied Bandwidth (20dB)

Ambient condition

Temperature	Relative humidity	Pressure
23°C ~25°C	45%~50%	101.5kPa

Method of Measurement

The EUT was connected to the spectrum analyzer and Bluetooth test set via a power splitter with a known loss. The occupied bandwidth is measured using spectrum analyzer. RBW is set to 20kHz and VBW is set to 62kHz on spectrum analyzer. -20dB occupied bandwidths are recorded.

Test Setup

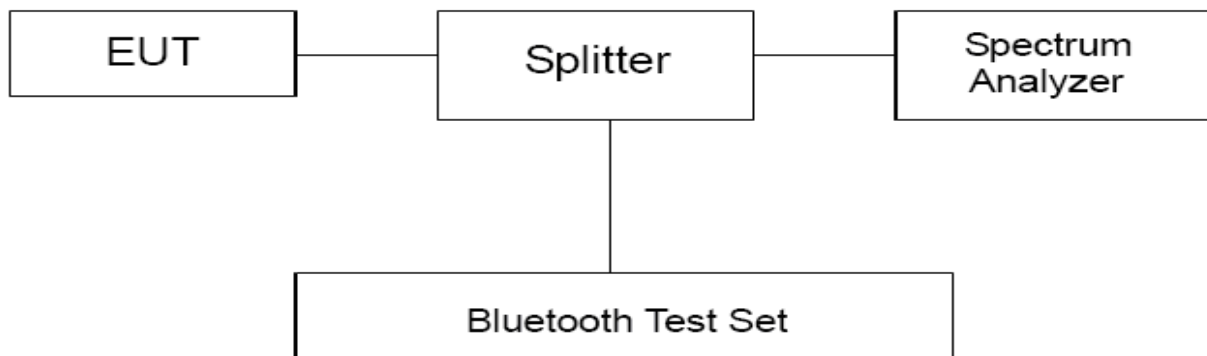

Limits

No specific occupied bandwidth requirements in part 15.247(a) (1).

Measurement Uncertainty

The assessed measurement uncertainty to ensure 95% confidence level for the normal distribution is with the coverage factor $k = 2$, $U = 936$ Hz.

TA Technology (Shanghai) Co., Ltd. Test Report

Report No.: RXA1407-0191RF03

Page 15 of 93

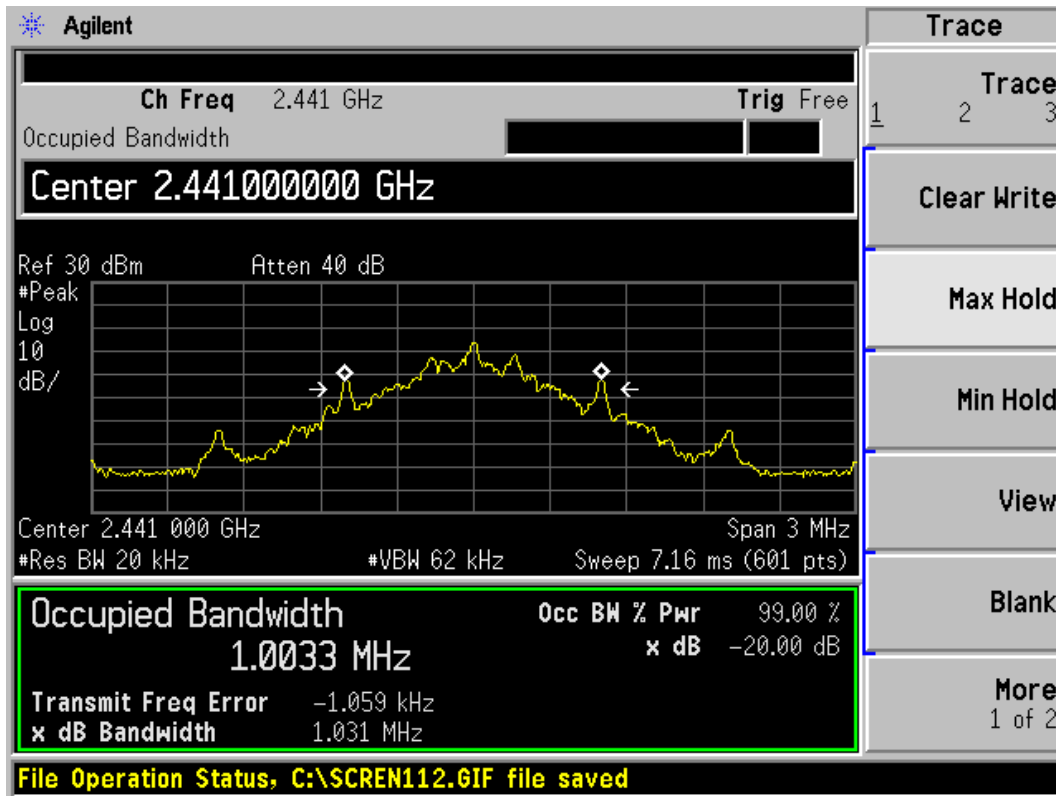

Carrier frequency (MHz): 2441
Channel No.:39

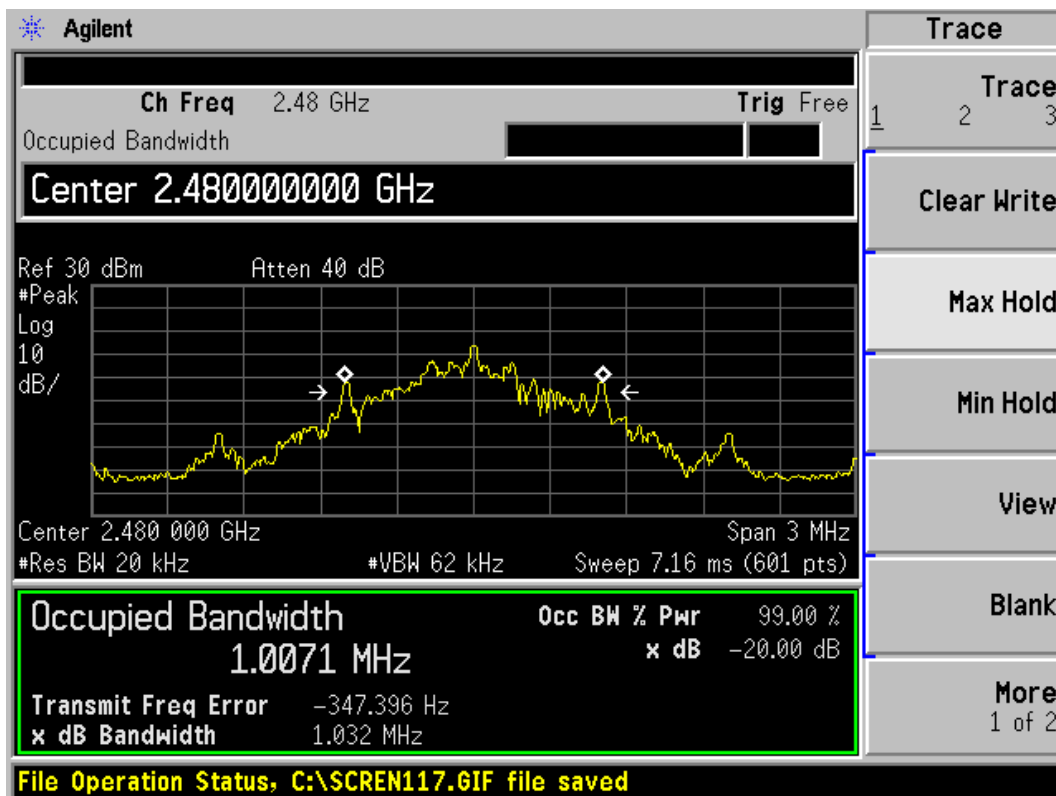

Carrier frequency (MHz): 2480
Channel No.:78

TA Technology (Shanghai) Co., Ltd. Test Report

Report No.: RXA1407-0191RF03

Page 16 of 93

2DH5

Channel	Frequency (MHz)	20dB Bandwidth (kHz)
0	2402	1083
39	2441	1085
78	2480	1081

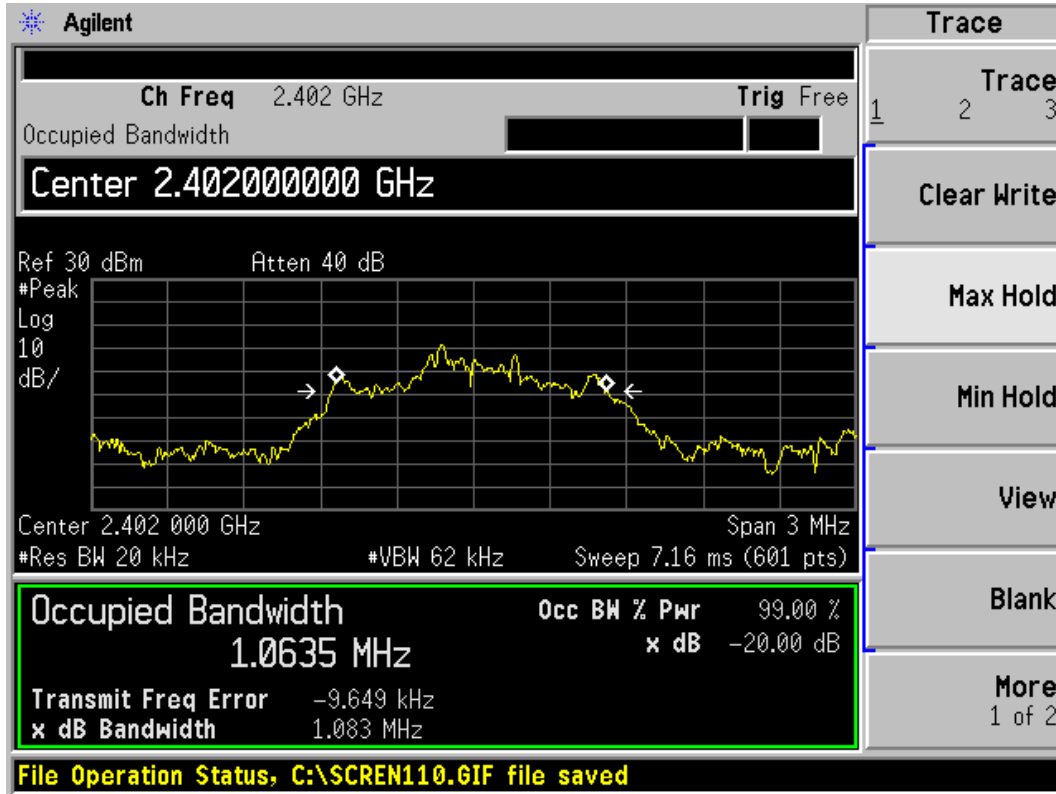

Carrier frequency (MHz): 2402

Channel No.: 0

TA Technology (Shanghai) Co., Ltd. Test Report

Report No.: RXA1407-0191RF03

Page 17 of 93

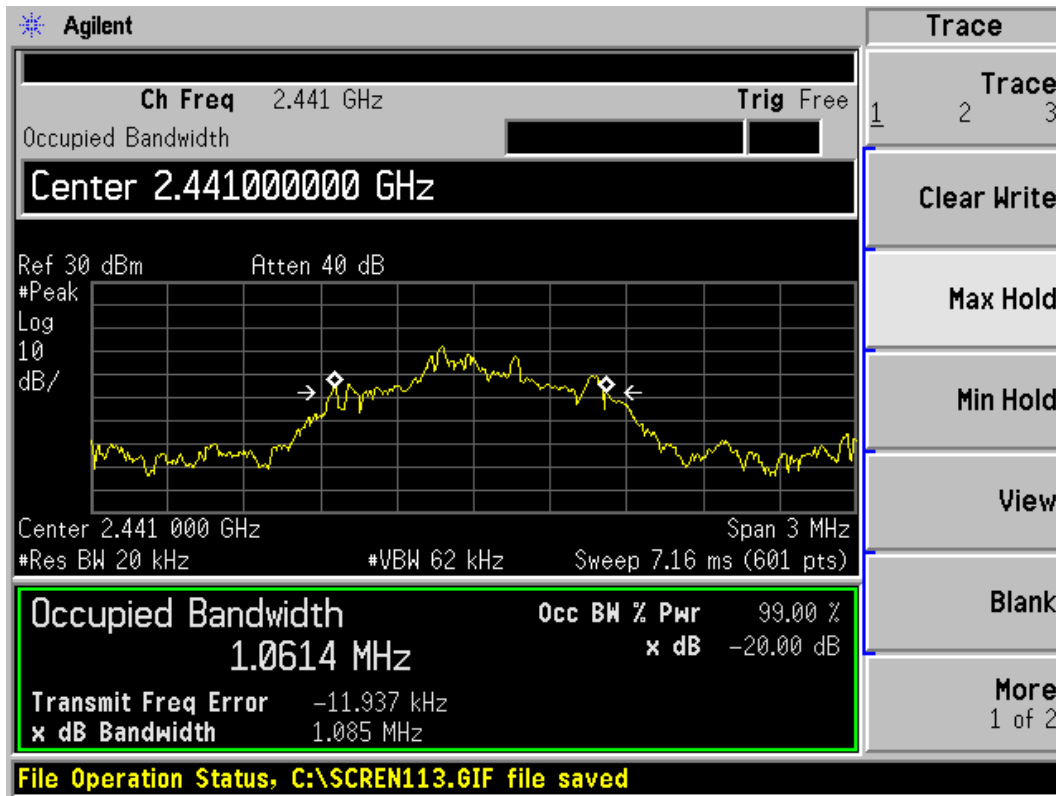

Carrier frequency (MHz): 2441
Channel No.:39

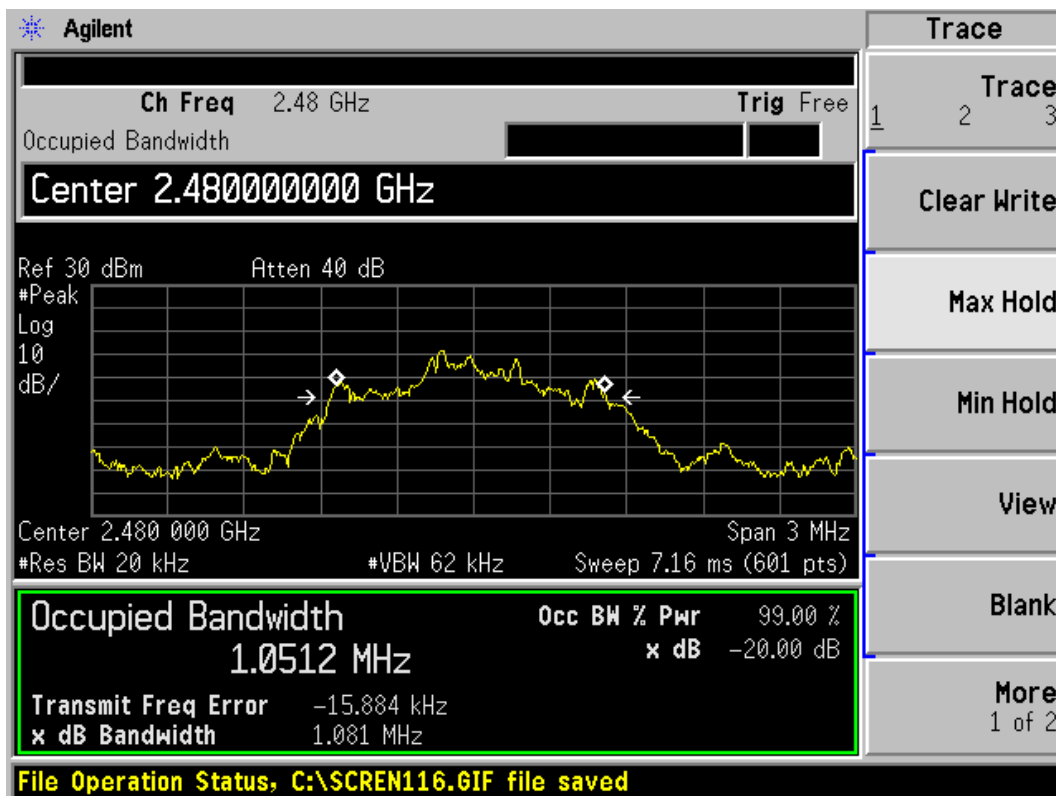

Carrier frequency (MHz): 2480
Channel No.:78

TA Technology (Shanghai) Co., Ltd. Test Report

Report No.: RXA1407-0191RF03

Page 18 of 93

3DH5

Channel	Frequency (MHz)	20dB Bandwidth (kHz)
0	2402	1176
39	2441	1175
78	2480	1158

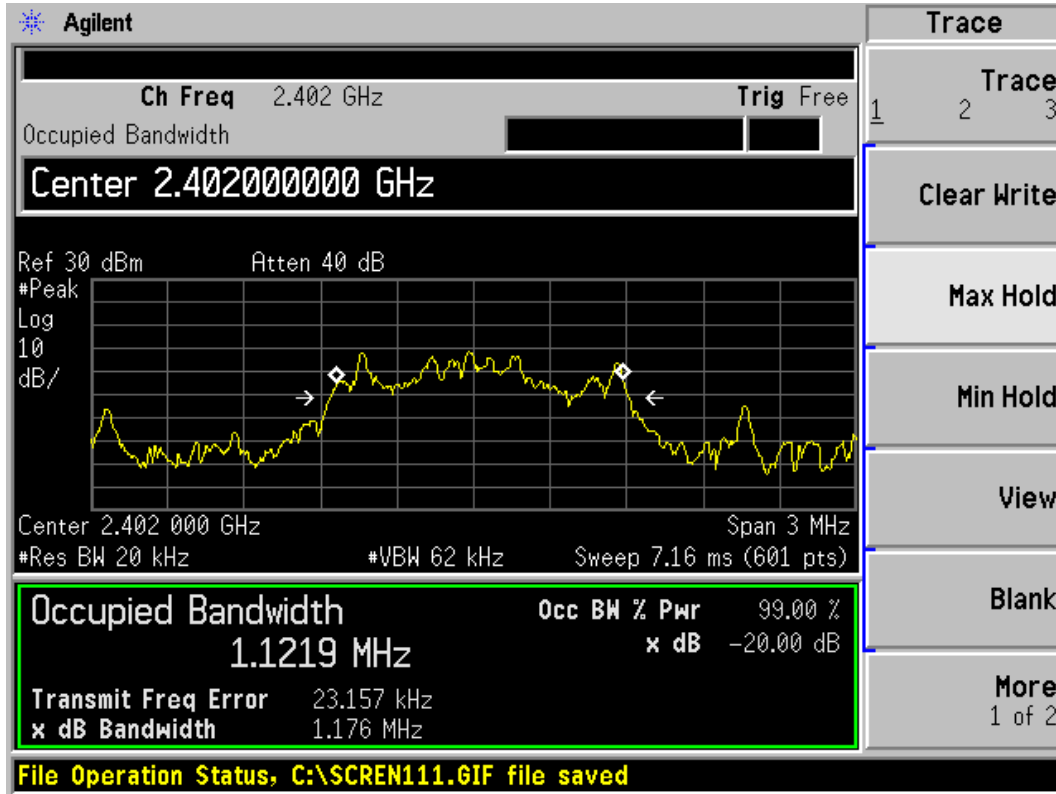

Carrier frequency (MHz): 2402

Channel No.:0

TA Technology (Shanghai) Co., Ltd. Test Report

Report No.: RXA1407-0191RF03

Page 19 of 93

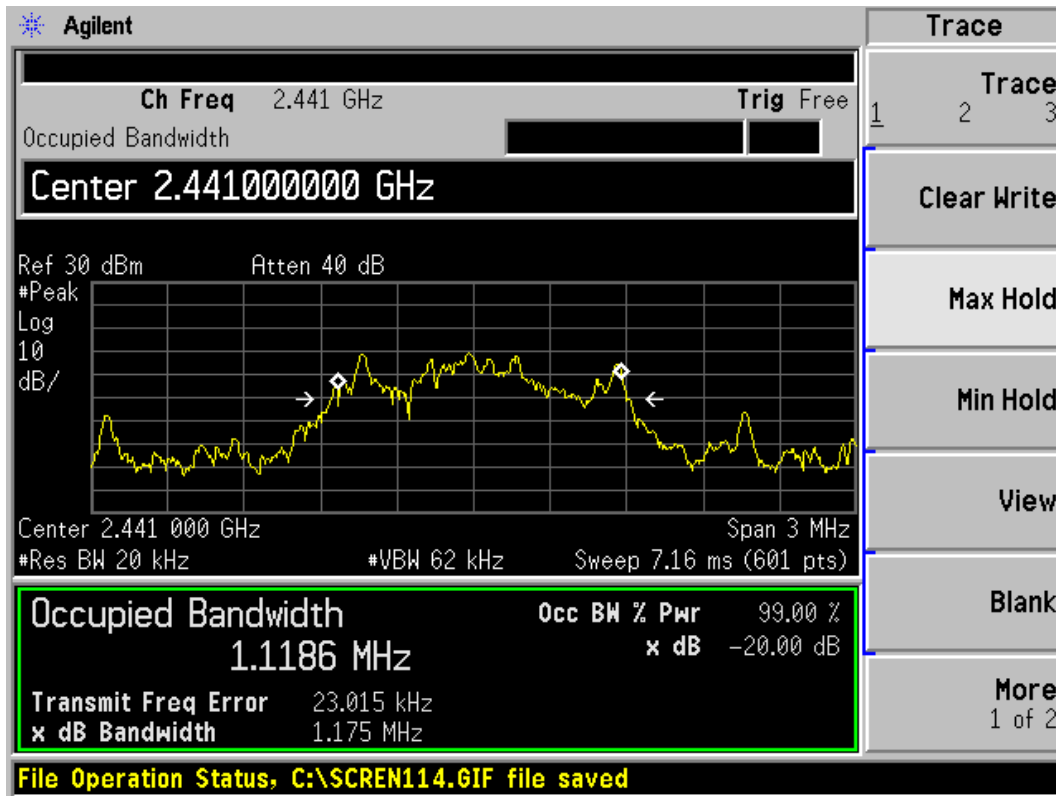

Carrier frequency (MHz): 2441
Channel No.:39

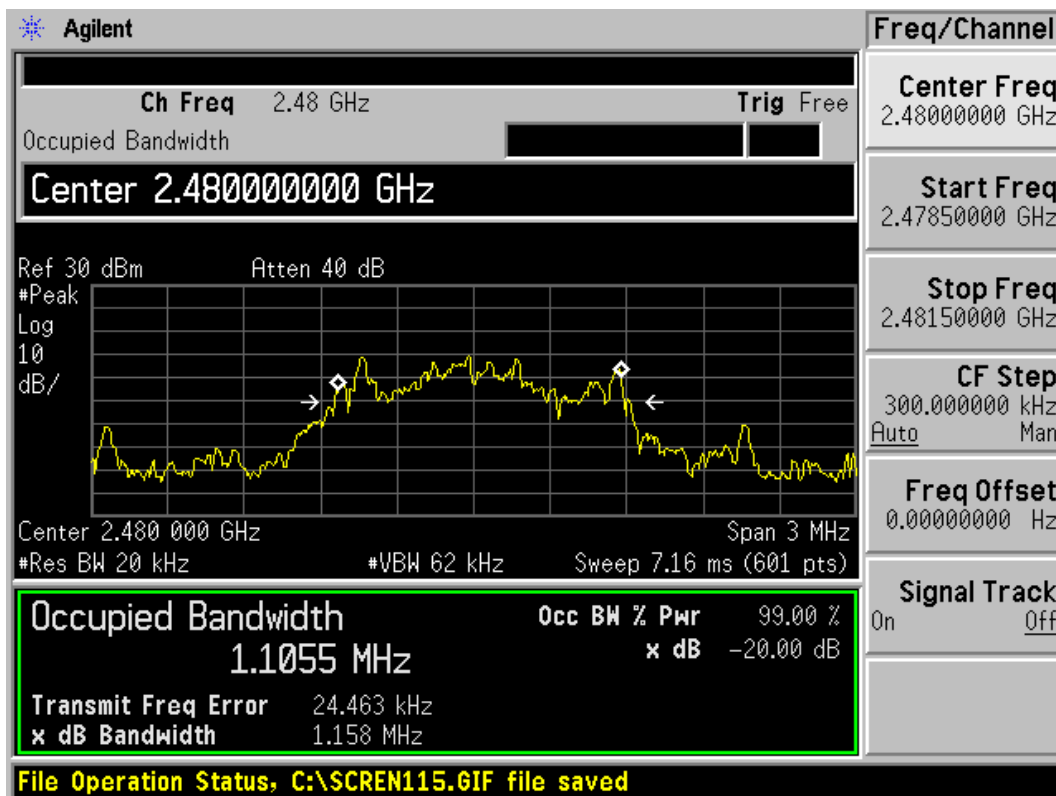

Carrier frequency (MHz): 2480
Channel No.:78

TA Technology (Shanghai) Co., Ltd.

Test Report

Report No.: RXA1407-0191RF03

Page 20 of 93

3.5. Frequency Separation

Ambient condition

Temperature	Relative humidity	Pressure
23°C ~25°C	45%~50%	101.5kPa

Method of Measurement

The EUT was connected to the spectrum analyzer and Bluetooth test set via a power splitter with a known loss. RBW is set to 300 kHz and VBW is set to 3MHz on spectrum analyzer. Set EUT on Hopping on mode.

Test setup

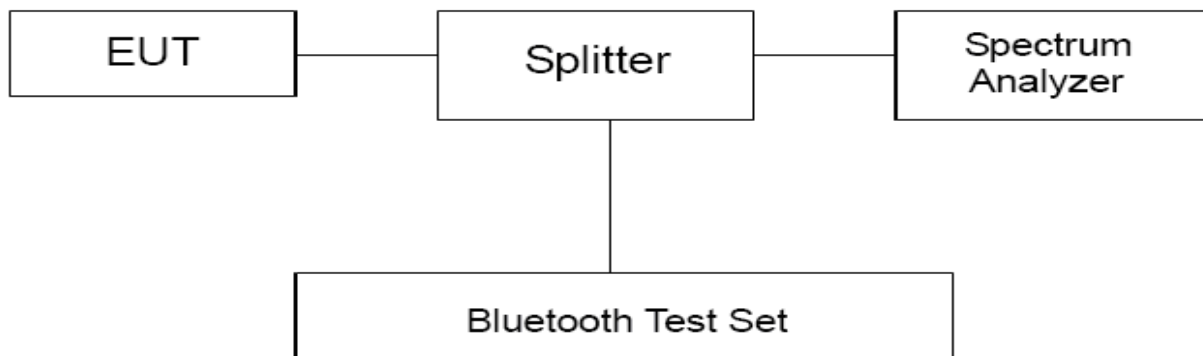

Limits

Rule Part 15.247(a)(1) specifies that “Frequency hopping systems shall have hopping channel carrier frequencies separated by a minimum of 25 kHz or the 20 dB bandwidth of the hopping channel, whichever is greater. Alternatively, frequency hopping systems operating in the 2400–2483.5 MHz band may have hopping channel carrier frequencies that are separated by 25 kHz or two-thirds of the 20 dB bandwidth of the hopping channel, whichever is greater, provided the systems operate with an output power no greater than 125 mW. ”

Note: The value of two-thirds of 20 dB bandwidth is always greater than 25 kHz.

Measurement Uncertainty

The assessed measurement uncertainty to ensure 95% confidence level for the normal distribution is with the coverage factor $k = 2$, $U = 936$ Hz.

TA Technology (Shanghai) Co., Ltd. Test Report

Test Results:

DH5

Carrier frequency (MHz)	Carrier frequency separation(kHz)	20dB Bandwidth (kHz)	Limit(kHz)	Conclusion
2402	1002	1032	688	PASS
2441	1002	1031	687	PASS
2480	1002	1032	688	PASS

Note: The limit is two-thirds of 20 dB bandwidth.

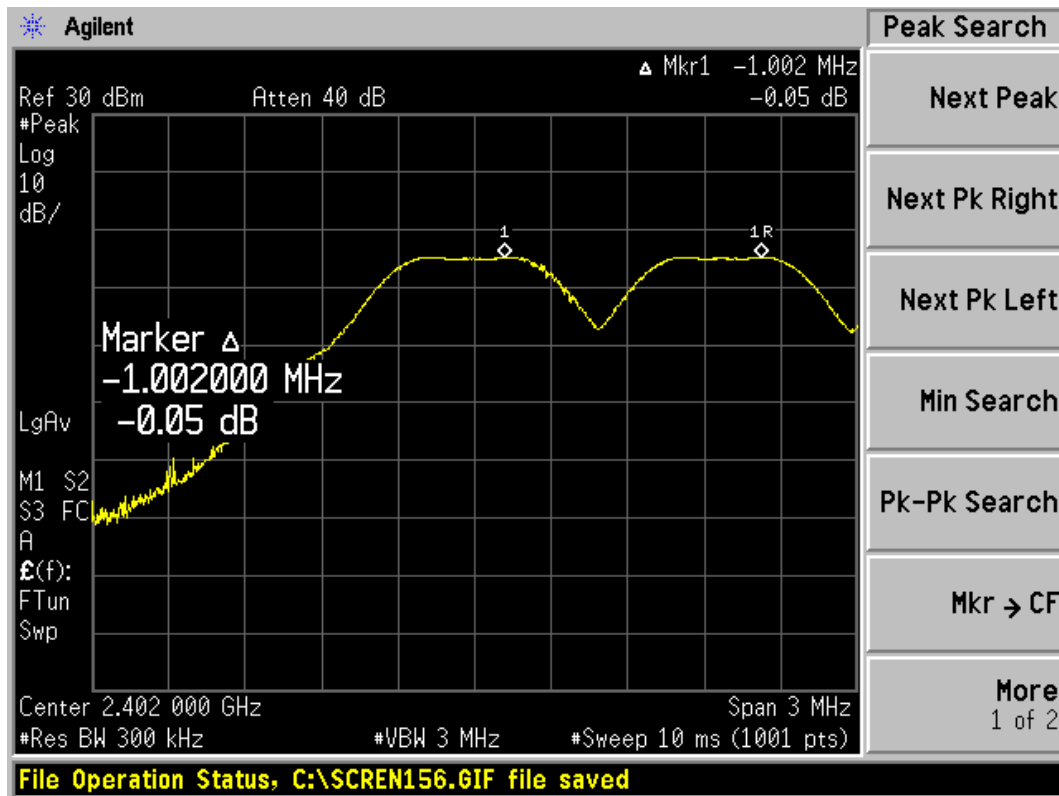

Carrier frequency (MHz): 2402

Channel No.:0

TA Technology (Shanghai) Co., Ltd. Test Report

Report No.: RXA1407-0191RF03

Page 22 of 93

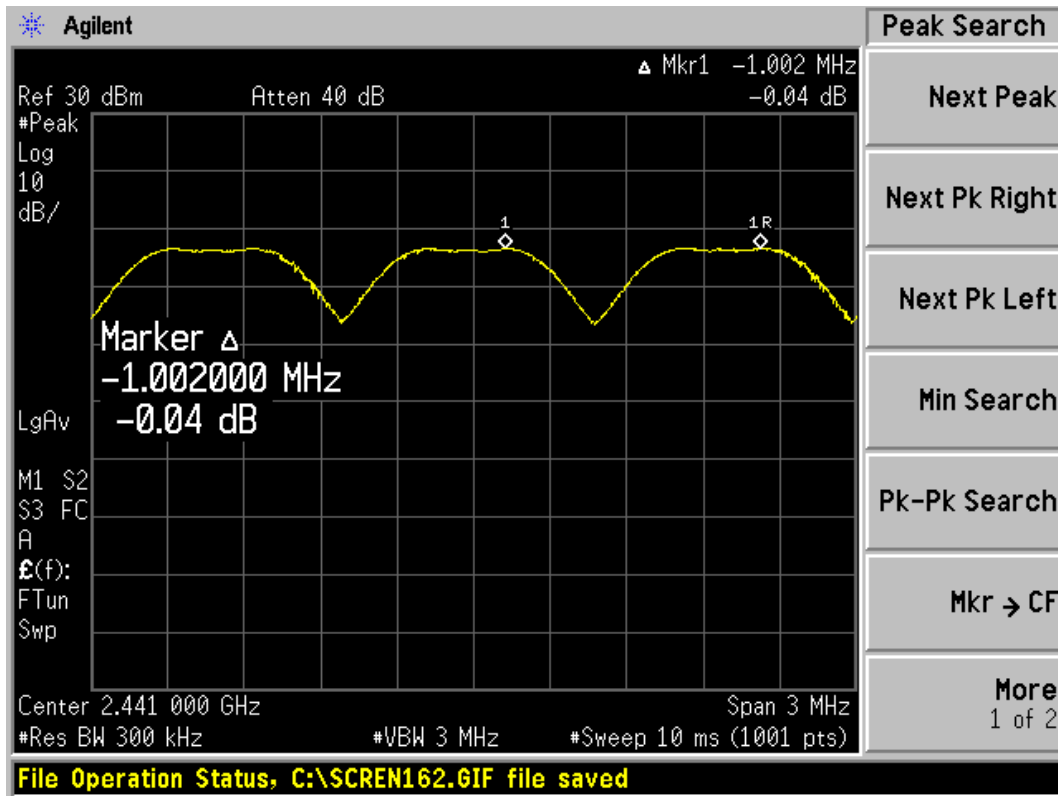

Carrier frequency (MHz): 2441

Channel No.:39

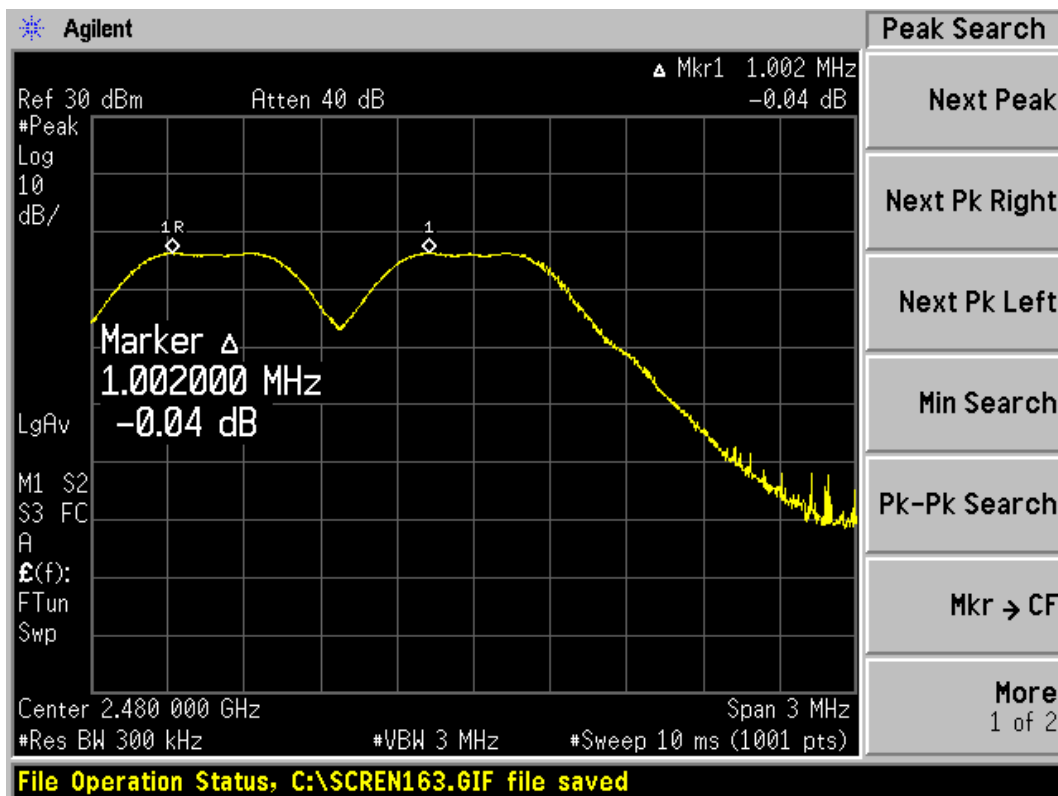

Carrier frequency (MHz): 2480

Channel No.:78

TA Technology (Shanghai) Co., Ltd. Test Report

Report No.: RXA1407-0191RF03

Page 23 of 93

2DH5

Carrier frequency (MHz)	Carrier frequency separation(kHz)	20dB Bandwidth (kHz)	Limit(kHz)	Conclusion
2402	1002	1083	722	PASS
2441	1011	1085	723	PASS
2480	1008	1081	721	PASS

Note: The limit is two-thirds of 20 dB bandwidth.

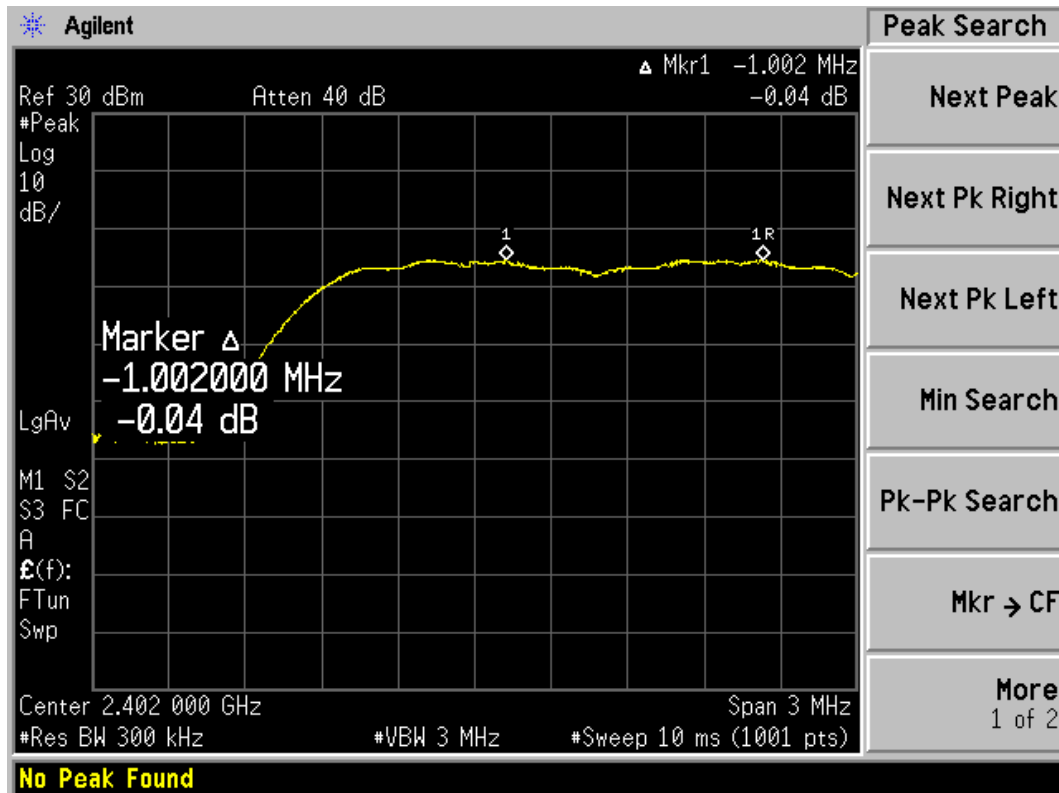

Carrier frequency (MHz): 2402

Channel No.:0

TA Technology (Shanghai) Co., Ltd. Test Report

Report No.: RXA1407-0191RF03

Page 24 of 93

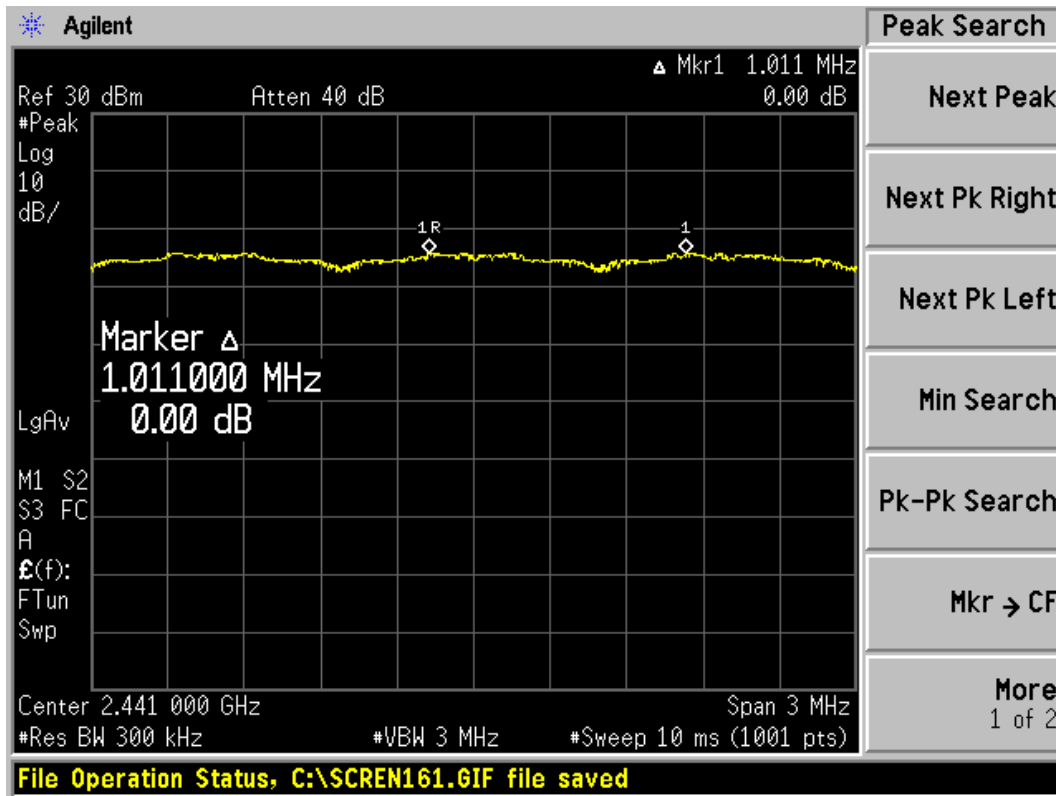

Carrier frequency (MHz): 2441
Channel No.:39

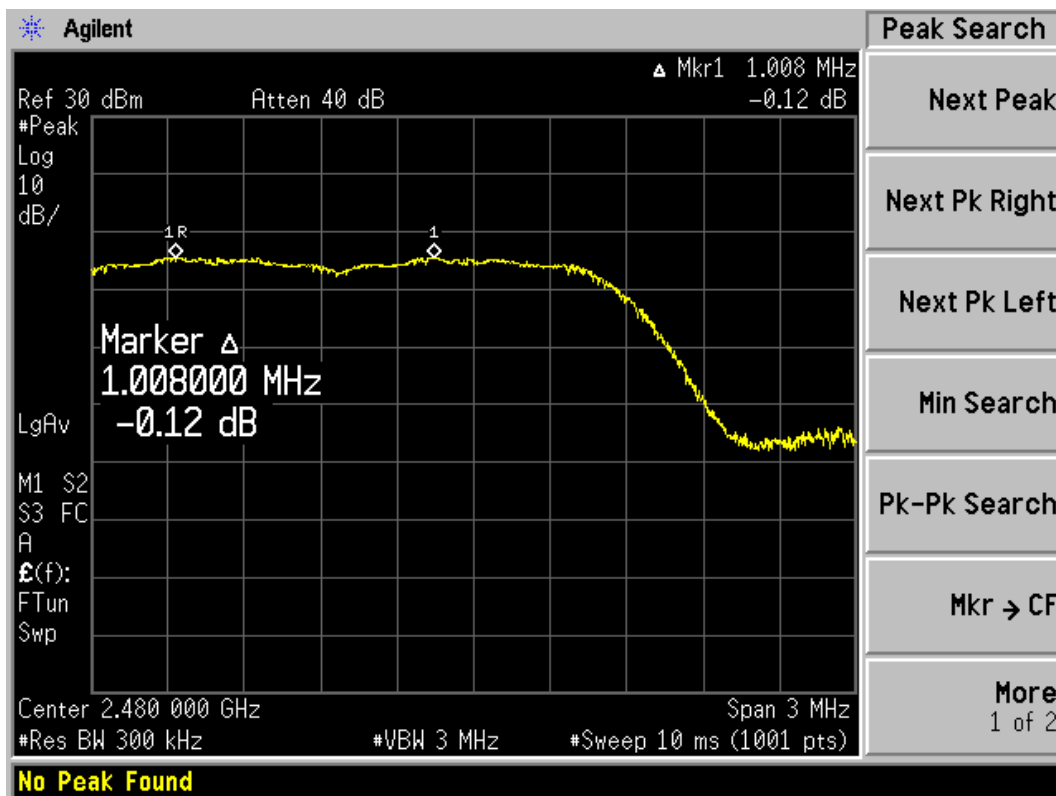

Carrier frequency (MHz): 2480
Channel No.:78

TA Technology (Shanghai) Co., Ltd. Test Report

Report No.: RXA1407-0191RF03

Page 25 of 93

3DH5

Carrier frequency (MHz)	Carrier frequency separation(kHz)	20dB Bandwidth (kHz)	Limit(kHz)	Conclusion
2402	1002	1176	784	PASS
2441	1008	1175	783	PASS
2480	1005	1158	772	PASS

Note: The limit is two-thirds of 20 dB bandwidth.

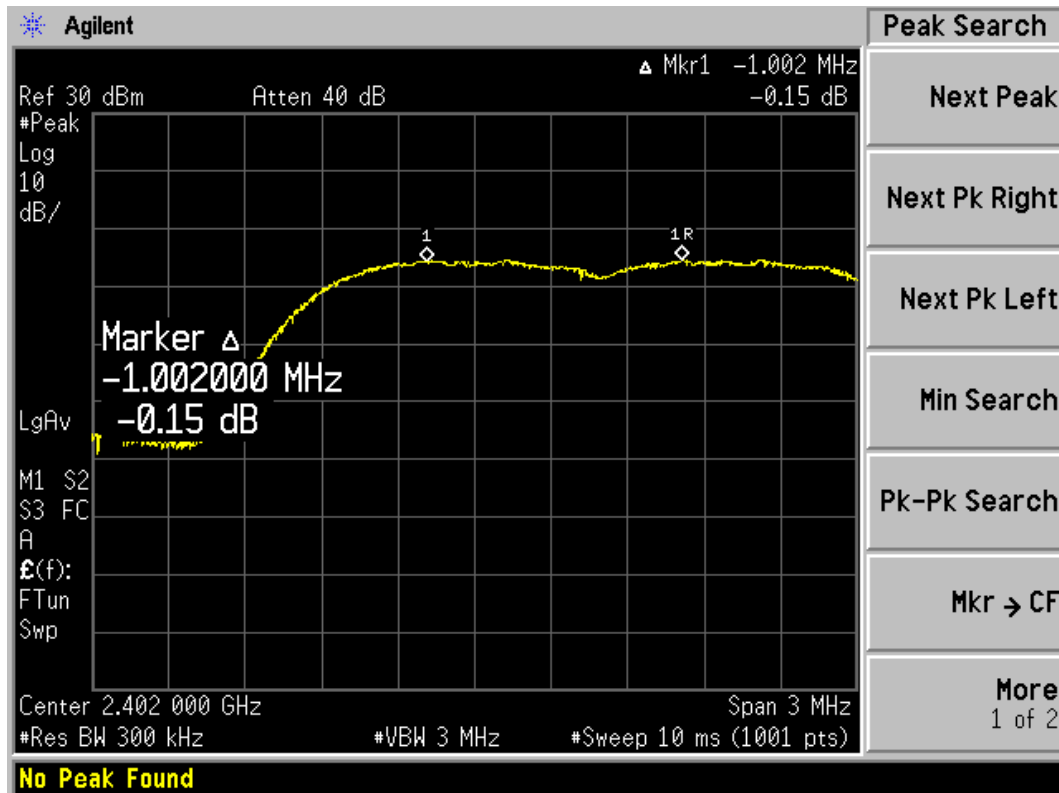

Carrier frequency (MHz): 2402

Channel No.:0

TA Technology (Shanghai) Co., Ltd. Test Report

Report No.: RXA1407-0191RF03

Page 26 of 93

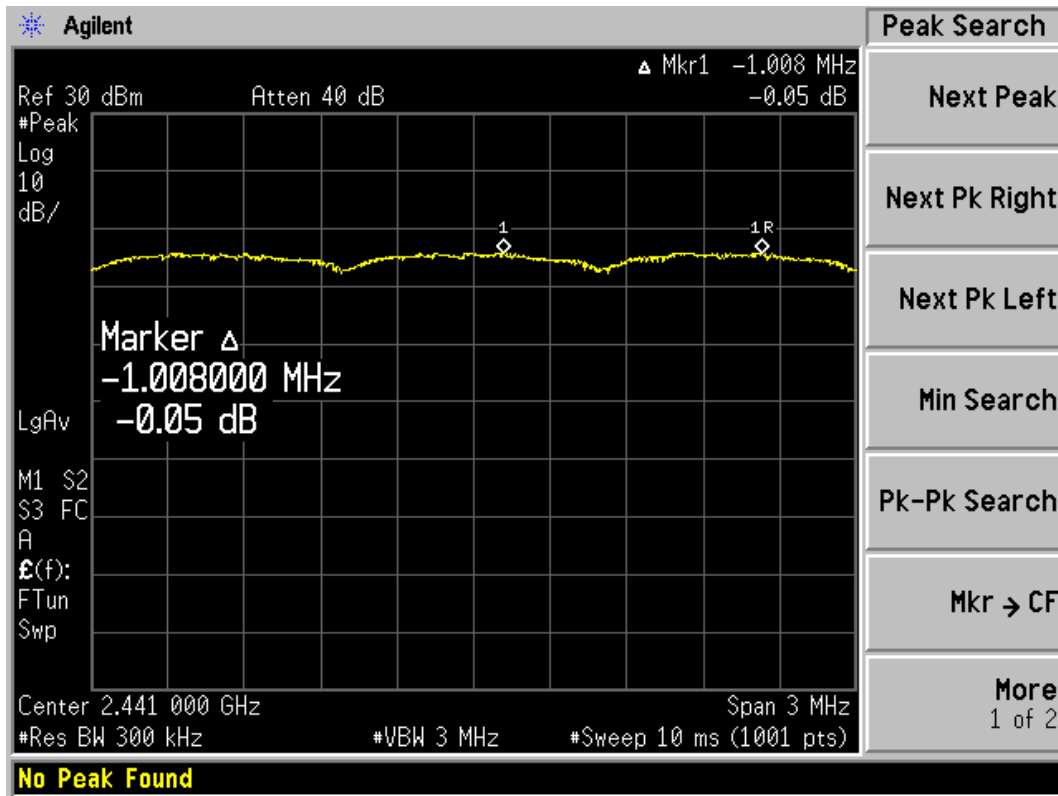

Carrier frequency (MHz): 2441
Channel No.:39

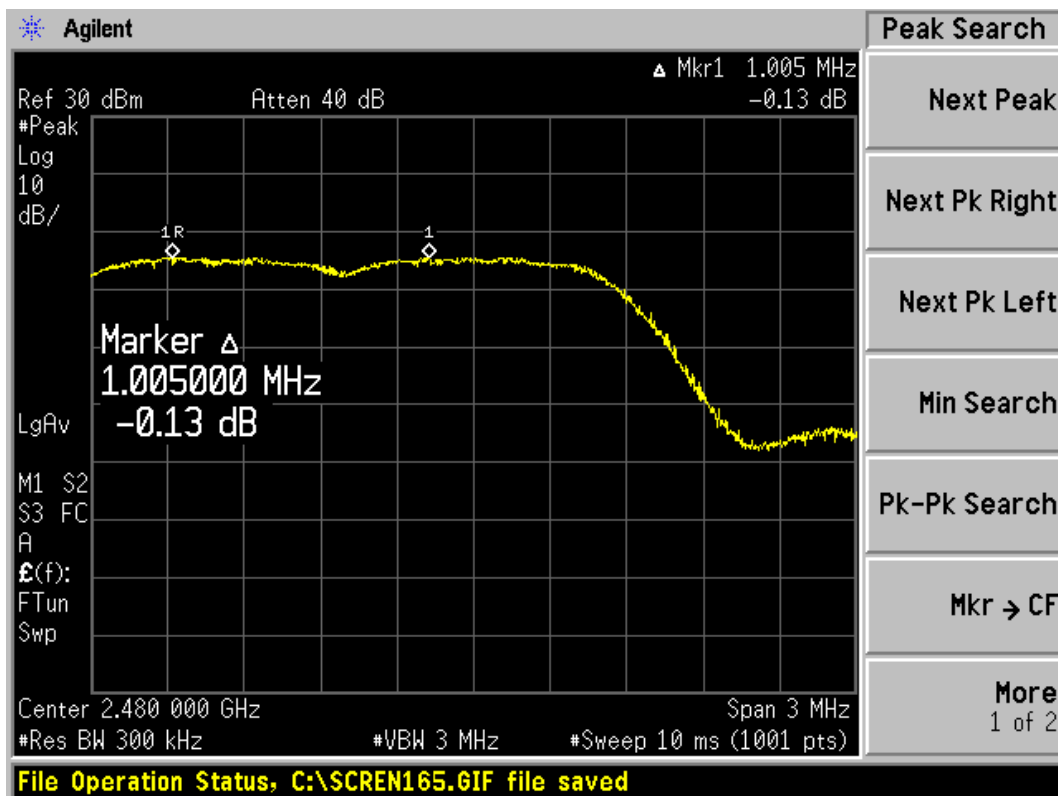

Carrier frequency (MHz): 2480
Channel No.:78

TA Technology (Shanghai) Co., Ltd. Test Report

3.6. Time of Occupancy (Dwell Time)

Ambient condition

Temperature	Relative humidity	Pressure
23°C ~25°C	45%~50%	101.5kPa

Methods of Measurement

The EUT was connected to the spectrum analyzer and Bluetooth test set via a power splitter with a known loss. RBW is set to 3MHz and VBW is set to 3MHz on spectrum analyzer .The time slot length is measured of three different packet types, which are available in the Bluetooth technology. Those are DH1, DH3 and DH5 packets. The dwell time is calculated by:

Dwell time = time slot length * hop rate * 0.4s with:

- hop rate=1600 * 1/s for DH1 packet =1600
- hop rate=1600/3 * 1/s for DH3 packet =533.33
- hop rate=1600/5 * 1/s for DH5 packet =320

Test Setup

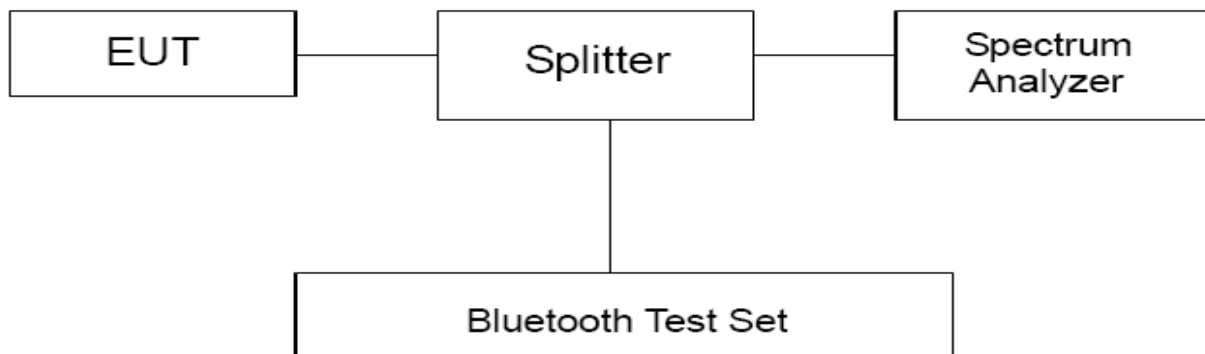

Limits

Rule Part 22.913(a) specifies that " Frequency hopping systems in the 2400–2483.5 MHz band shall use at least 15 channels. The average time of occupancy on any channel shall not be greater than 0.4 seconds within a period of 0.4 seconds multiplied by the number of hopping channels employed.."

Dwell time	$\leq 400\text{ms}$
------------	---------------------

TA Technology (Shanghai) Co., Ltd.

Test Report

Report No.: RXA1407-0191RF03

Page 28 of 93

Measurement Uncertainty

The assessed measurement uncertainty to ensure 95% confidence level for the normal distribution is with the coverage factor $k = 2$.

Requirements	Uncertainty	
Dwell Time	DH1	$U = 0.64\text{ms}$
	DH3	$U = 0.80\text{ms}$
	DH5	$U = 0.70\text{ms}$

TA Technology (Shanghai) Co., Ltd. Test Report

Report No.: RXA1407-0191RF03

Page 29 of 93

Test Results:

CH 39

Packet type	hop rate (1/s)	Time slot length(ms)	Dwell time (ms)	Limit (ms)	Conclusion
DH1	1600	0.367	234.880	400	PASS
DH3	533.33	1.633	348.371	400	PASS
DH5	320	2.850	364.800	400	PASS

Note: Dwell time = time slot length * hop rate * 0.4s

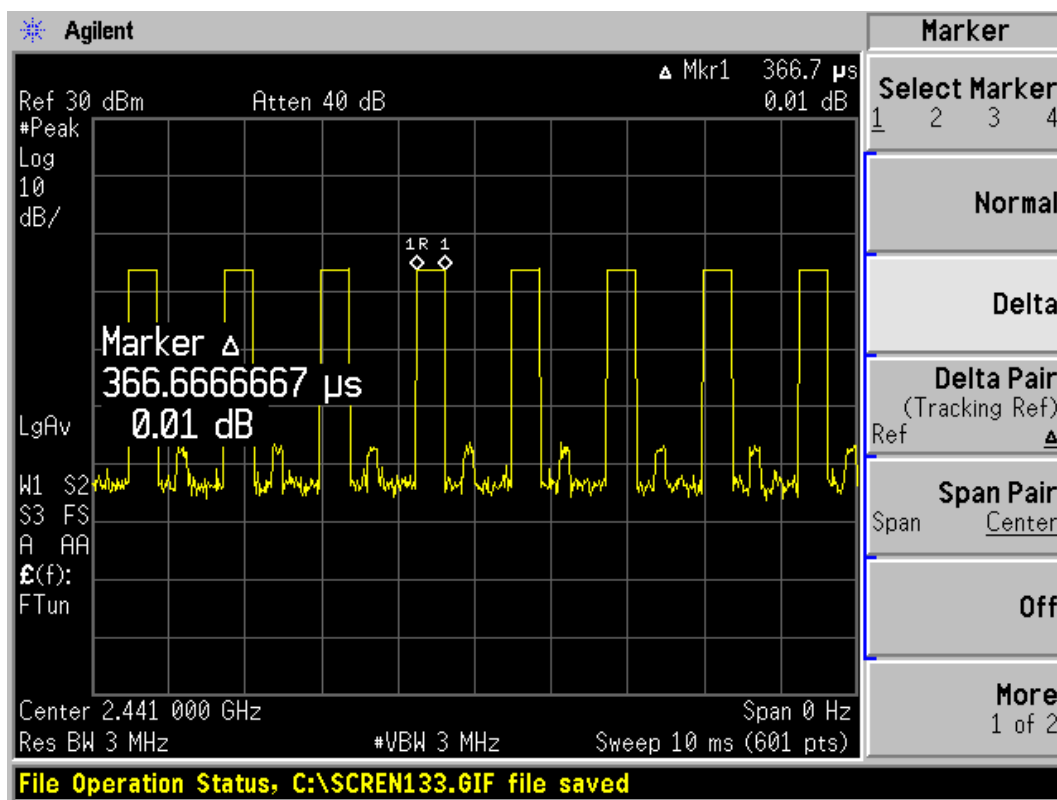

Carrier frequency (MHz): 2441,DH1

TA Technology (Shanghai) Co., Ltd. Test Report

Report No.: RXA1407-0191RF03

Page 30 of 93

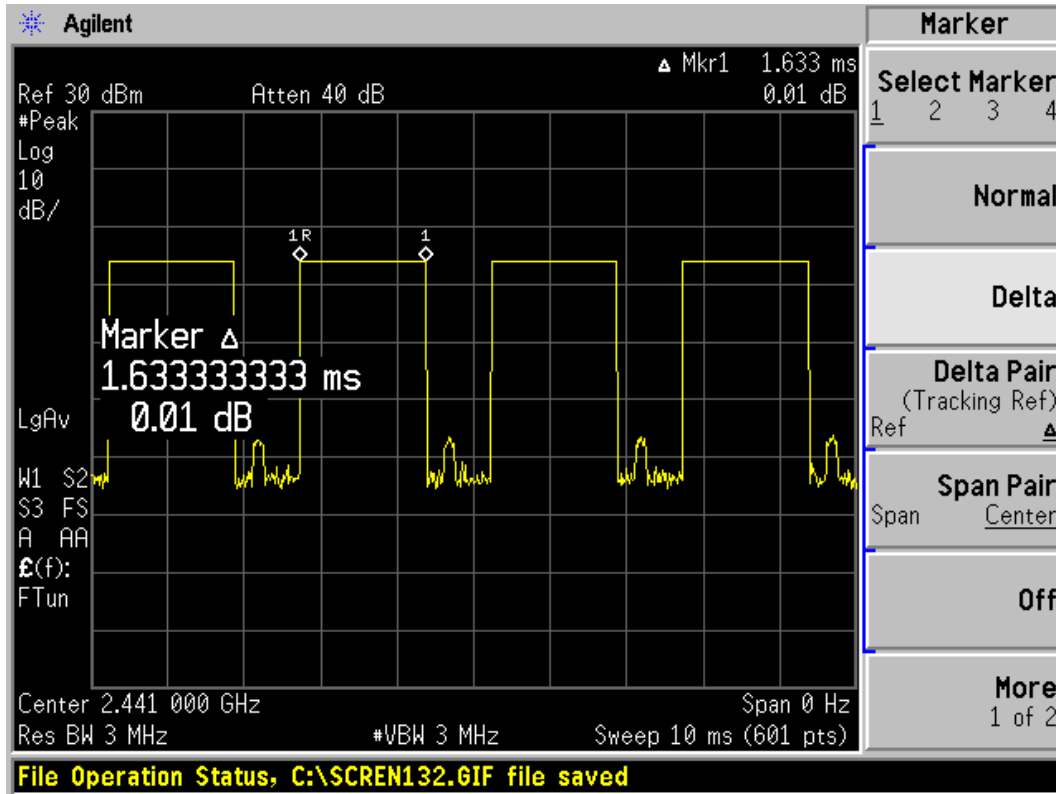

Carrier frequency (MHz): 2441,DH3

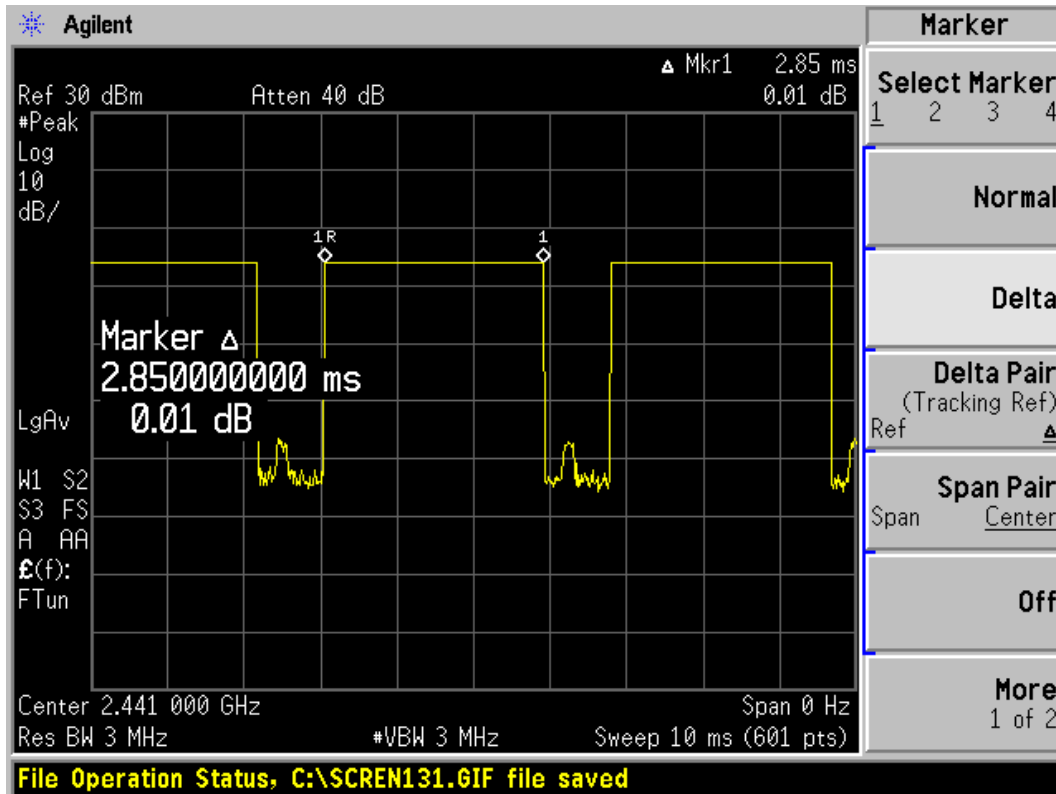

Carrier frequency (MHz): 2441,DH5

TA Technology (Shanghai) Co., Ltd.

Test Report

Report No.: RXA1407-0191RF03

Page 31 of 93

3.7. Band Edge Compliance

Ambient condition

Temperature	Relative humidity	Pressure
23°C ~25°C	45%~50%	101.5kPa

Method of Measurement

The EUT was connected to the spectrum analyzer and Bluetooth test set via a power splitter with a known loss. The lowest and highest channels were measured. The peak detector is used. RBW is set to 100 kHz and VBW is set to 300 kHz on spectrum analyzer. EUT test for Hopping On mode and Hopping Off mode.

Test Setup

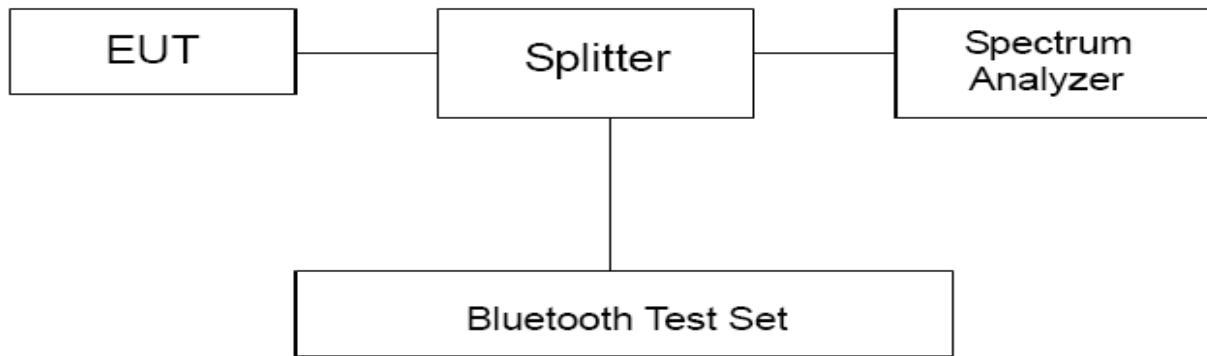

Limits

Rule Part 15.247(d) specifies that "In any 100 kHz bandwidth outside the frequency band in which the spread spectrum or digitally modulated intentional radiator is operating, the radio frequency power that is produced by the intentional radiator shall be at least 20 dB below that in the 100 kHz bandwidth within the band that contains the highest level of the desired power, based on either an RF conducted or a radiated measurement, provided the transmitter demonstrates compliance with the peak conducted power limits."

Measurement Uncertainty

The assessed measurement uncertainty to ensure 95% confidence level for the normal distribution is with the coverage factor $k = 1.96$.

Frequency	Uncertainty
2GHz-3GHz	1.407 dB

TA Technology (Shanghai) Co., Ltd. Test Report

Report No.: RXA1407-0191RF03

Page 32 of 93

Test Results: PASS

Hopping On-DH5-

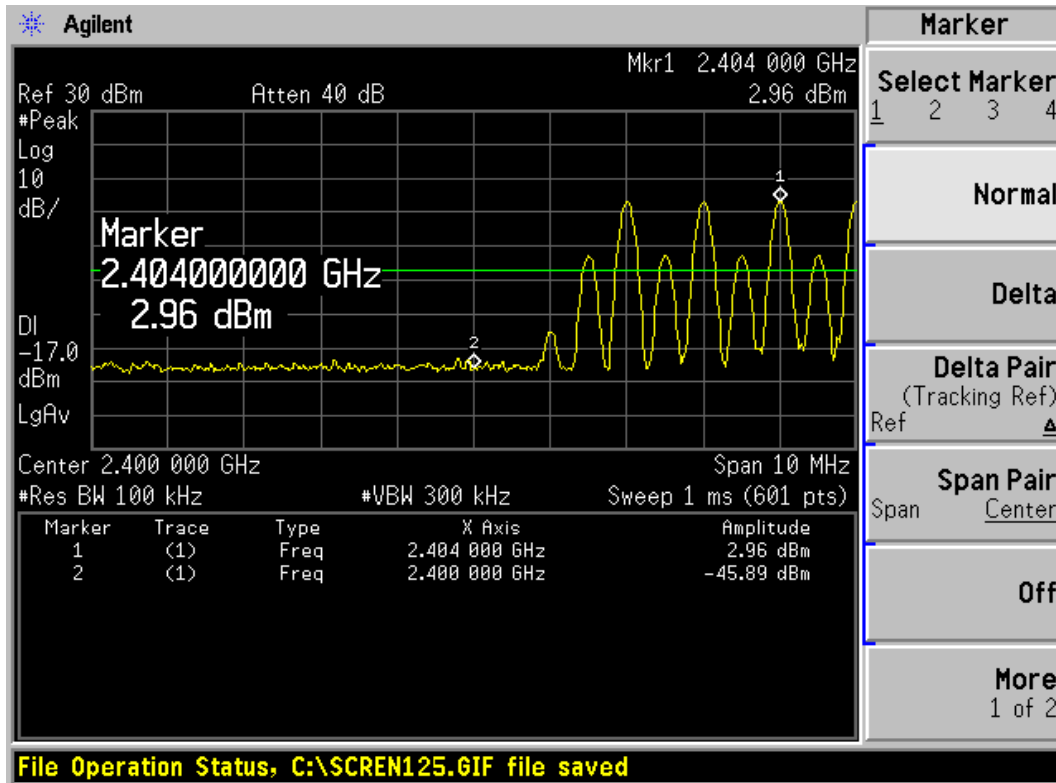

Carrier frequency (MHz): 2402

Channel No.:0

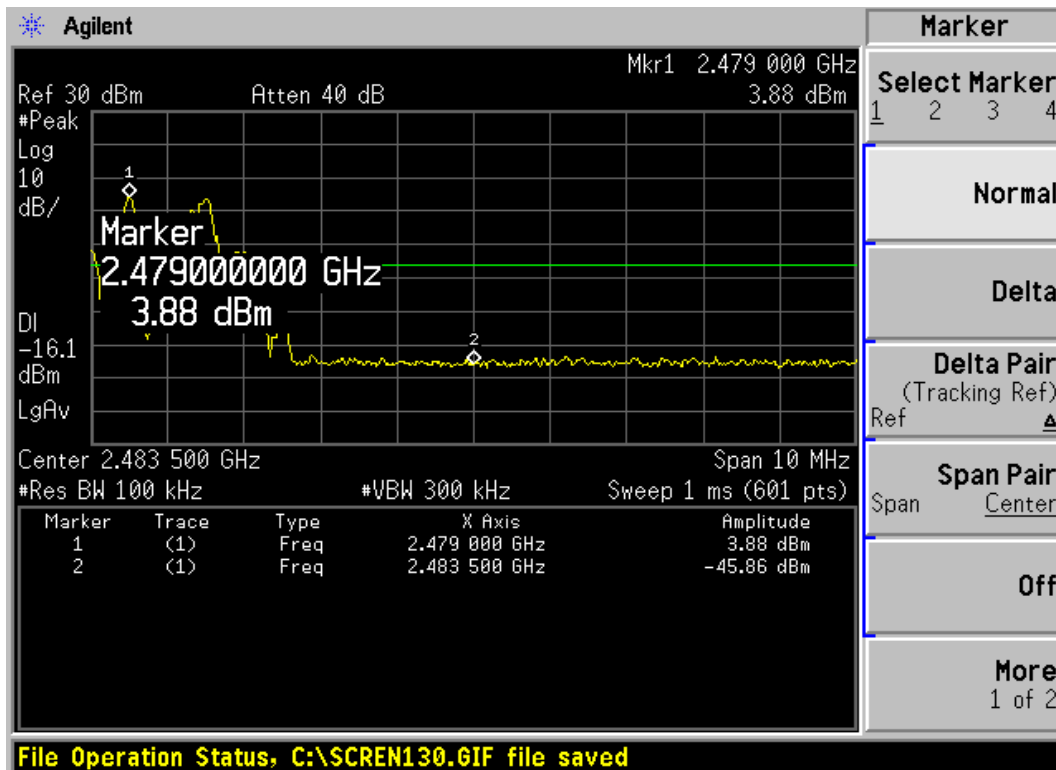

Carrier frequency (MHz): 2480

Channel No.:78

TA Technology (Shanghai) Co., Ltd. Test Report

Report No.: RXA1407-0191RF03

Page 33 of 93

Hopping On-2DH5

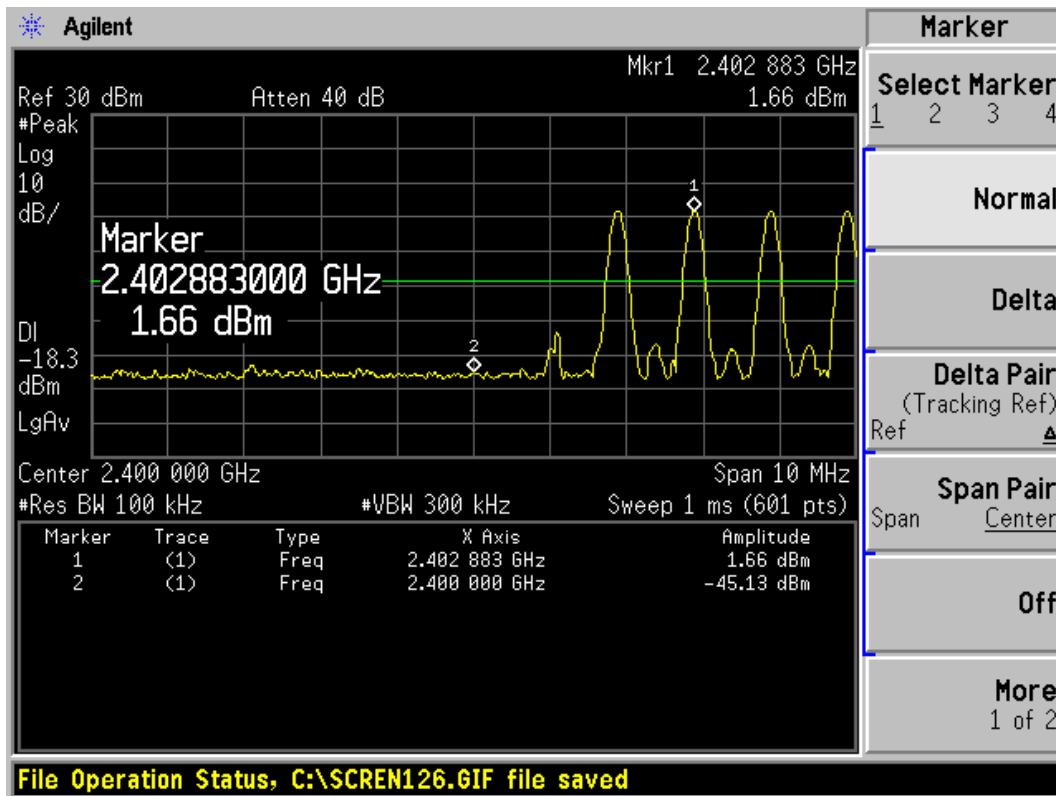

Carrier frequency (MHz): 2402
Channel No.:0

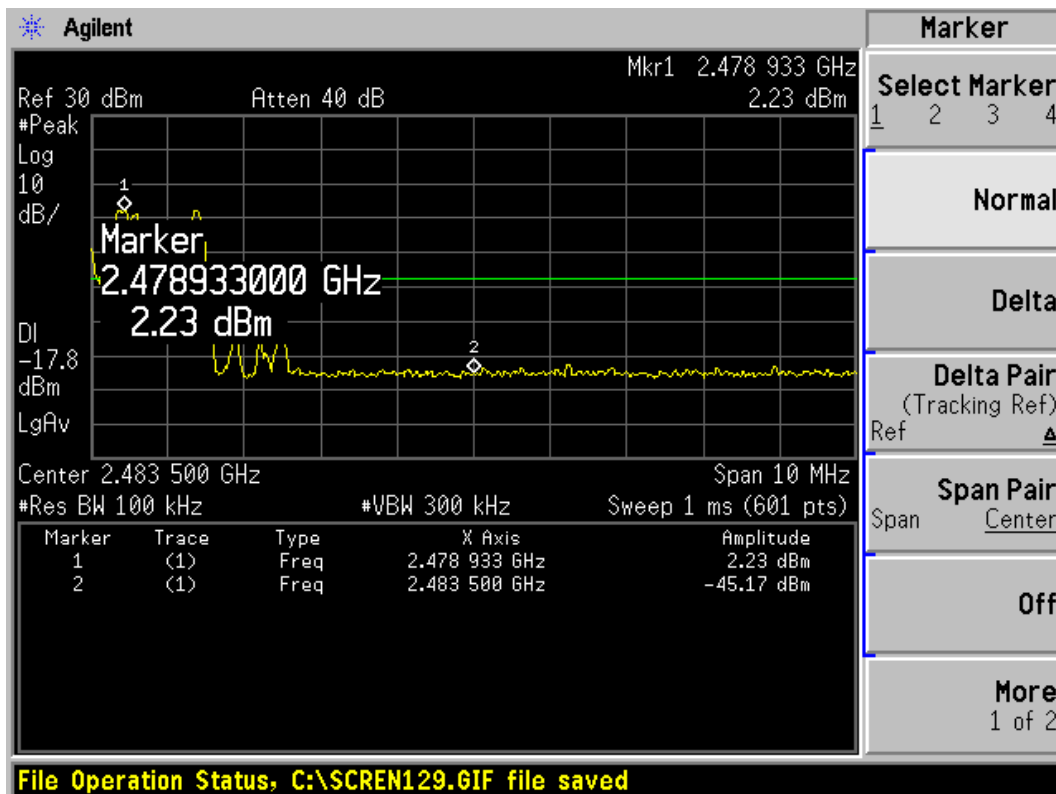

Carrier frequency (MHz): 2480
Channel No.:78

TA Technology (Shanghai) Co., Ltd. Test Report

Report No.: RXA1407-0191RF03

Page 34 of 93

Hopping On-3DH5

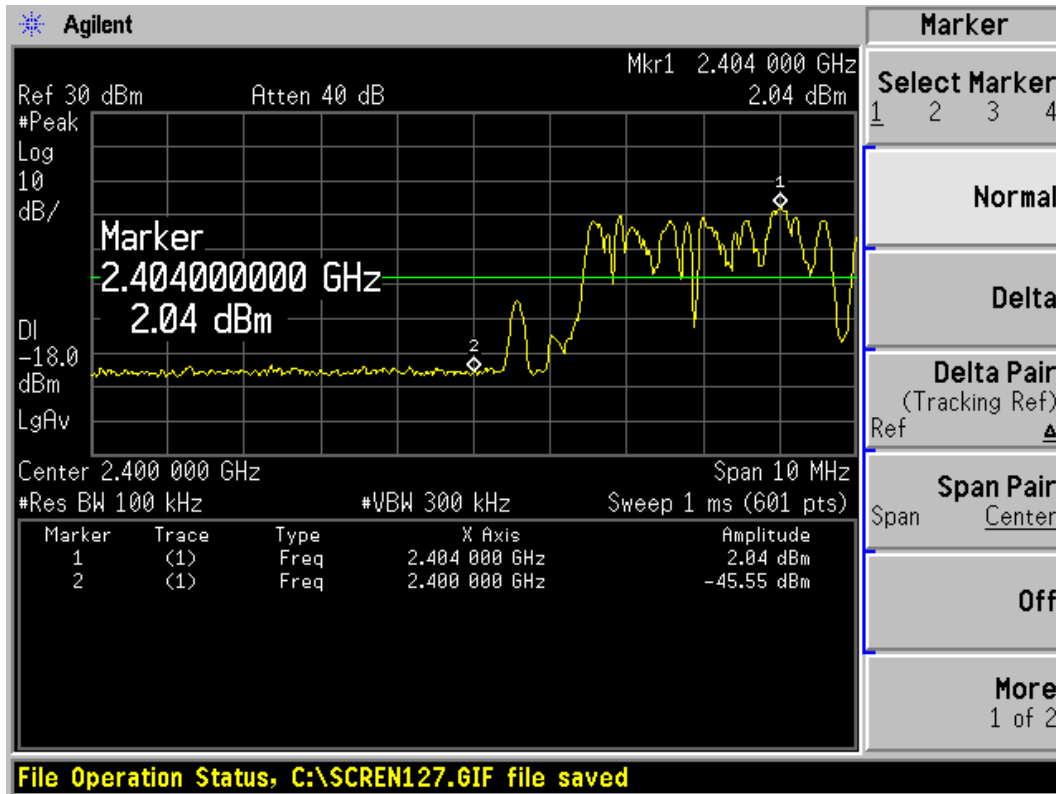

Carrier frequency (MHz): 2402
Channel No.:0

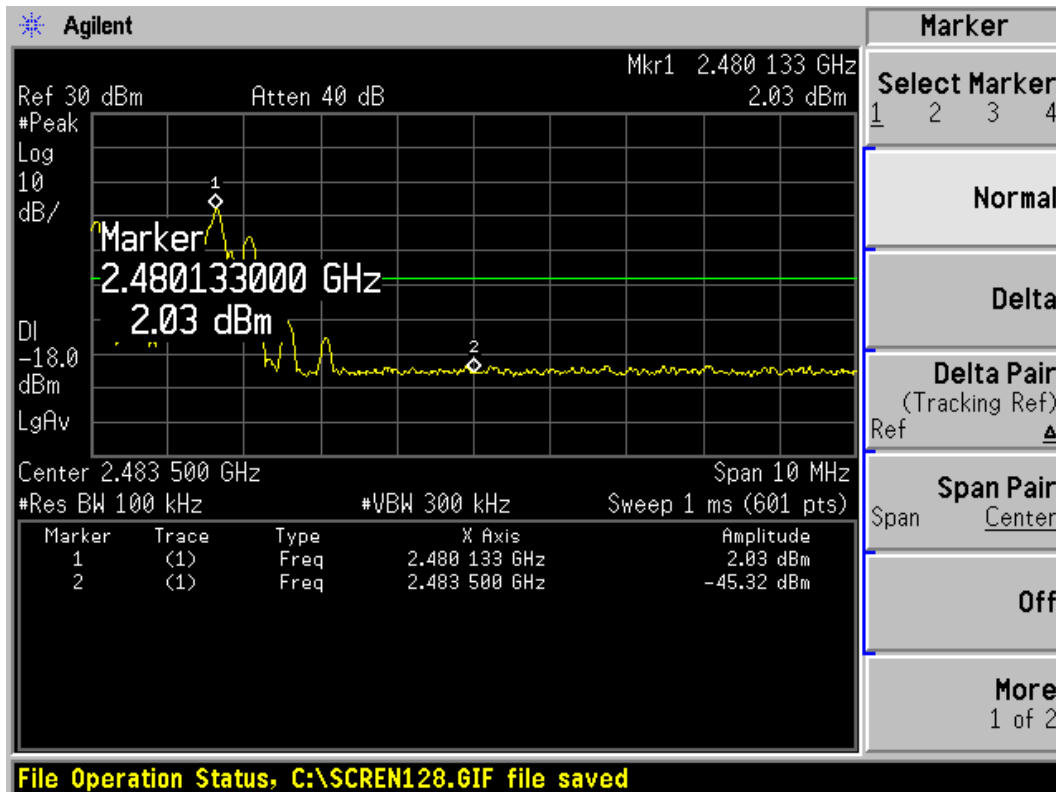

Carrier frequency (MHz): 2480
Channel No.:78

TA Technology (Shanghai) Co., Ltd. Test Report

Report No.: RXA1407-0191RF03

Page 35 of 93

Hopping Off-DH5

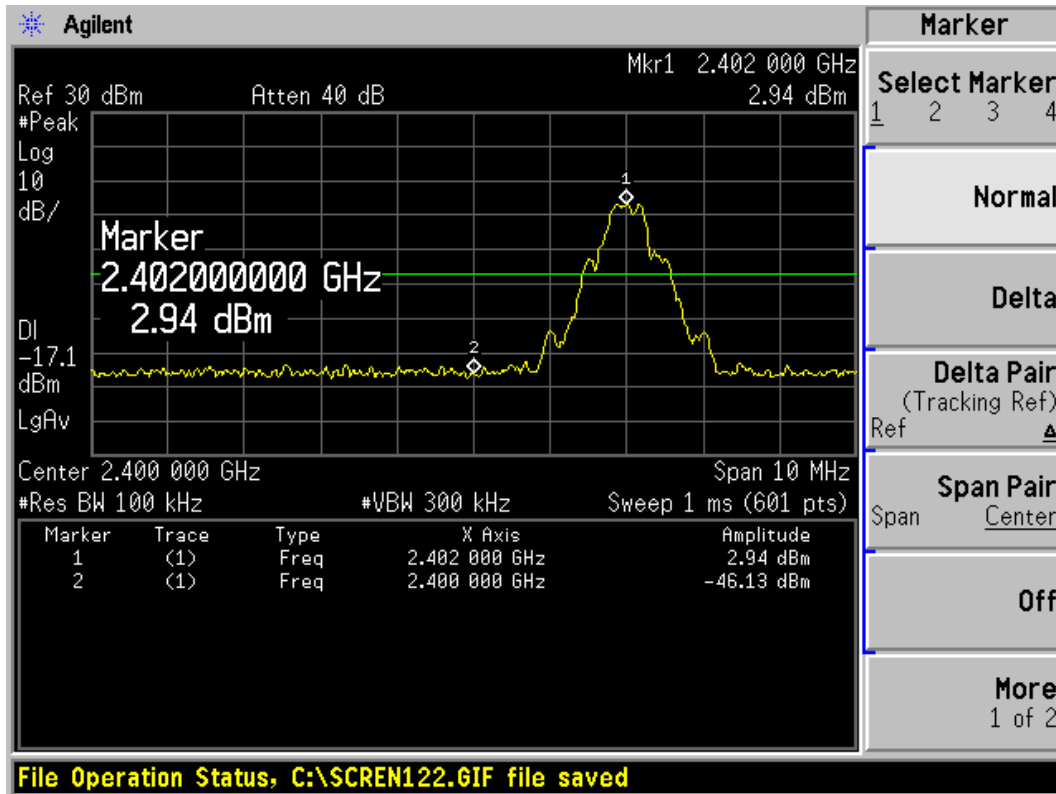

Carrier frequency (MHz): 2402
Channel No.:0

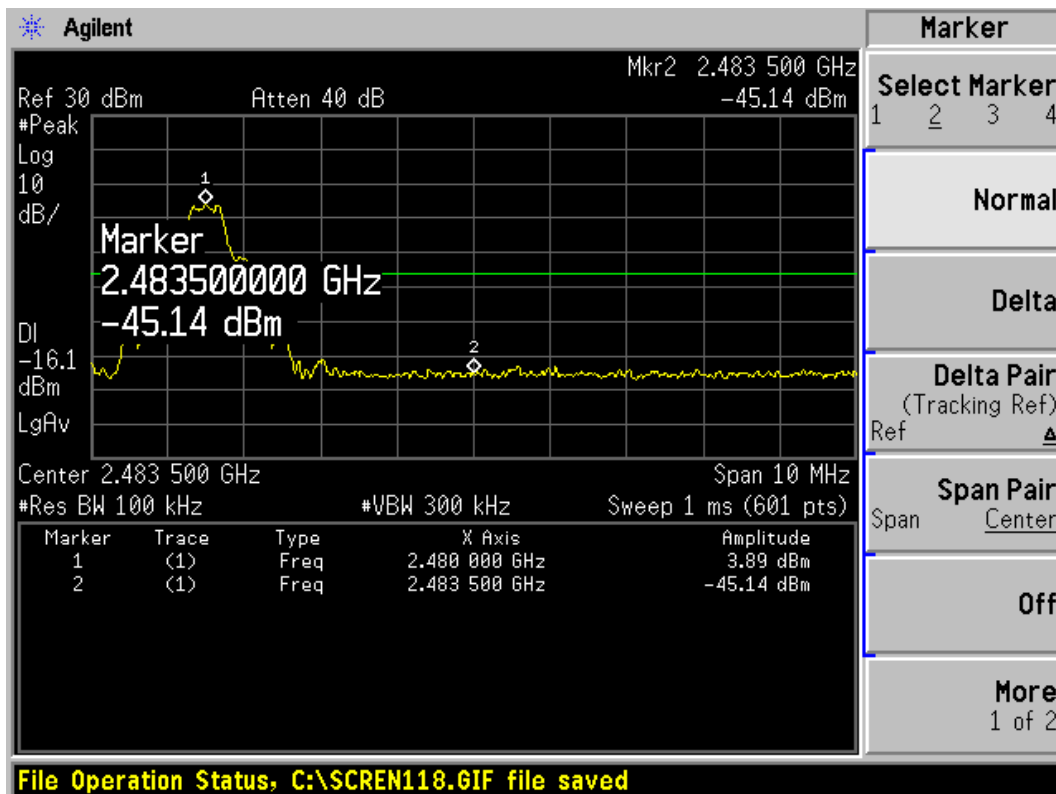

Carrier frequency (MHz): 2480
Channel No.:78

TA Technology (Shanghai) Co., Ltd. Test Report

Report No.: RXA1407-0191RF03

Page 36 of 93

Hopping Off-2DH5

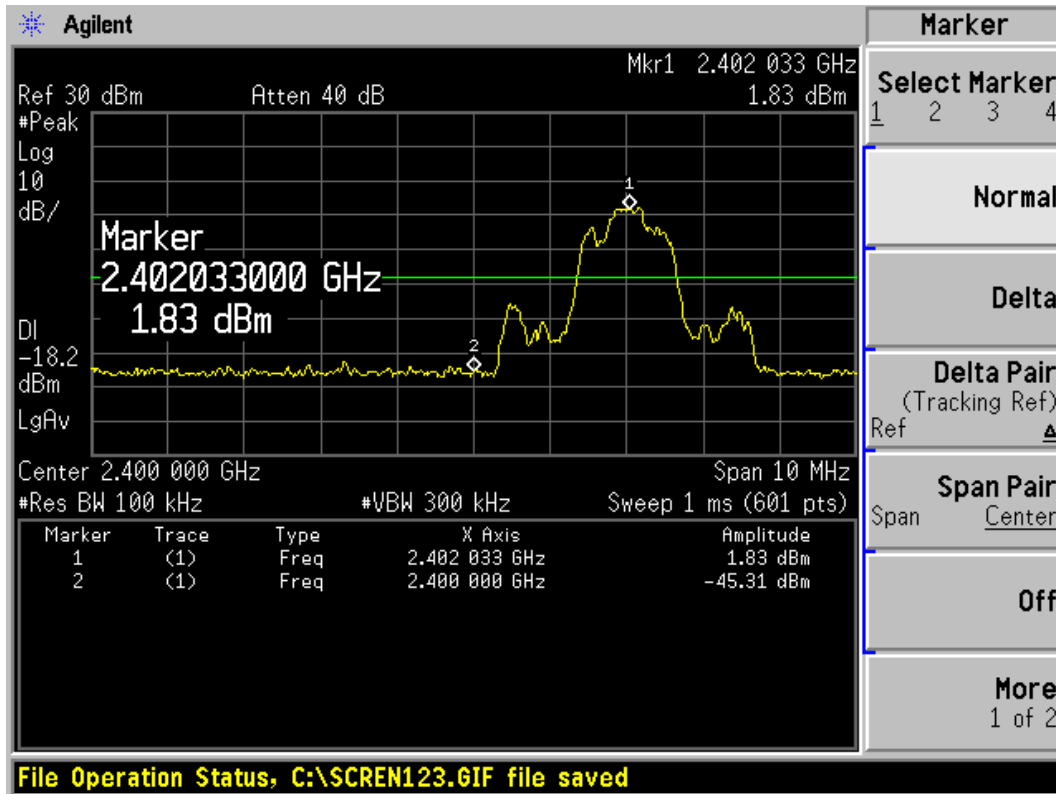

Carrier frequency (MHz): 2402
Channel No.:0

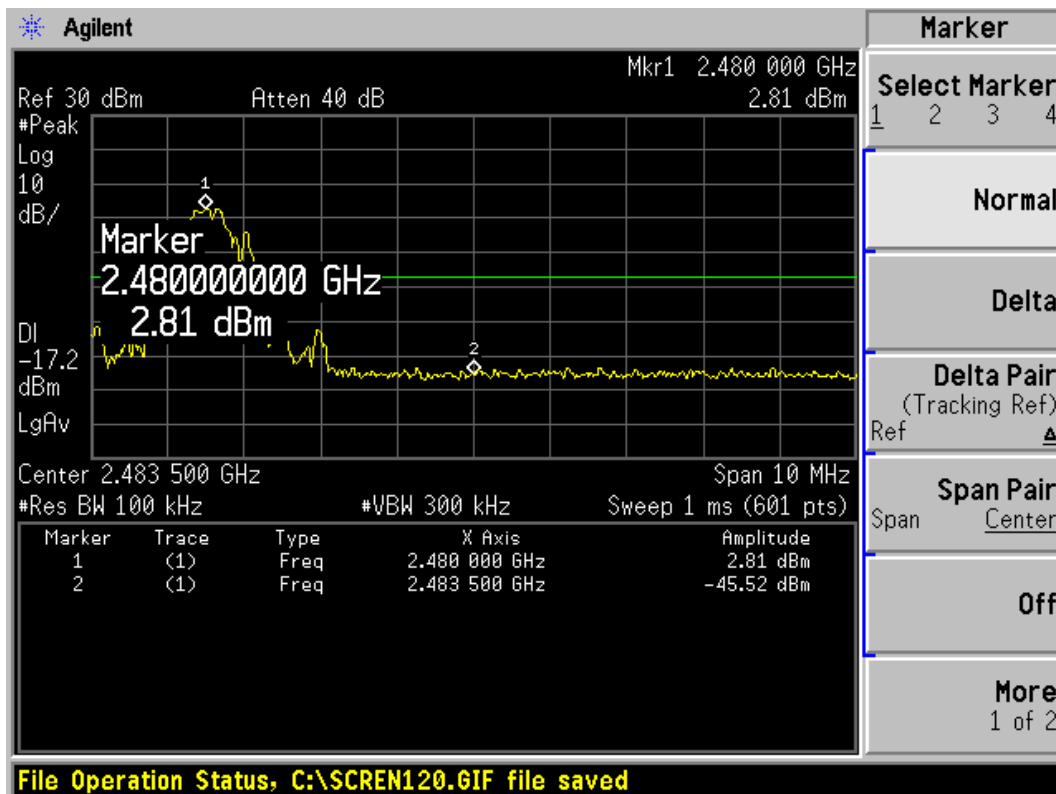

Carrier frequency (MHz): 2480
Channel No.:78

TA Technology (Shanghai) Co., Ltd. Test Report

Report No.: RXA1407-0191RF03

Page 37 of 93

Hopping Off-3DH5

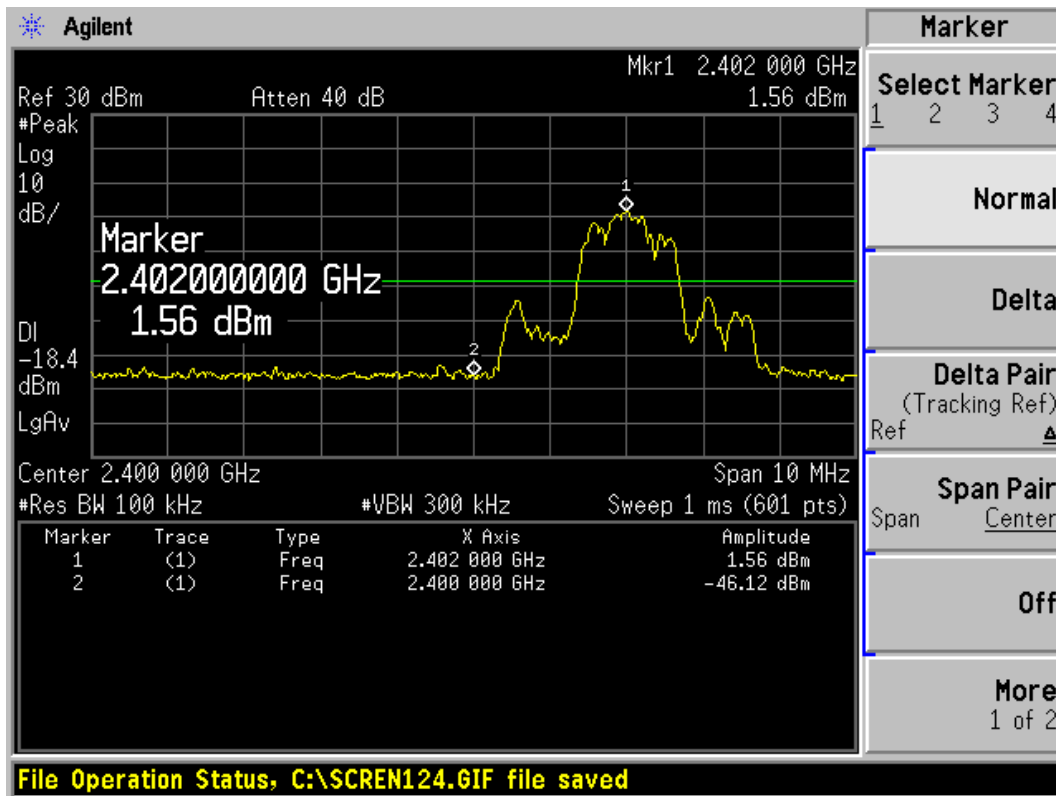

Carrier frequency (MHz): 2402
Channel No.:0

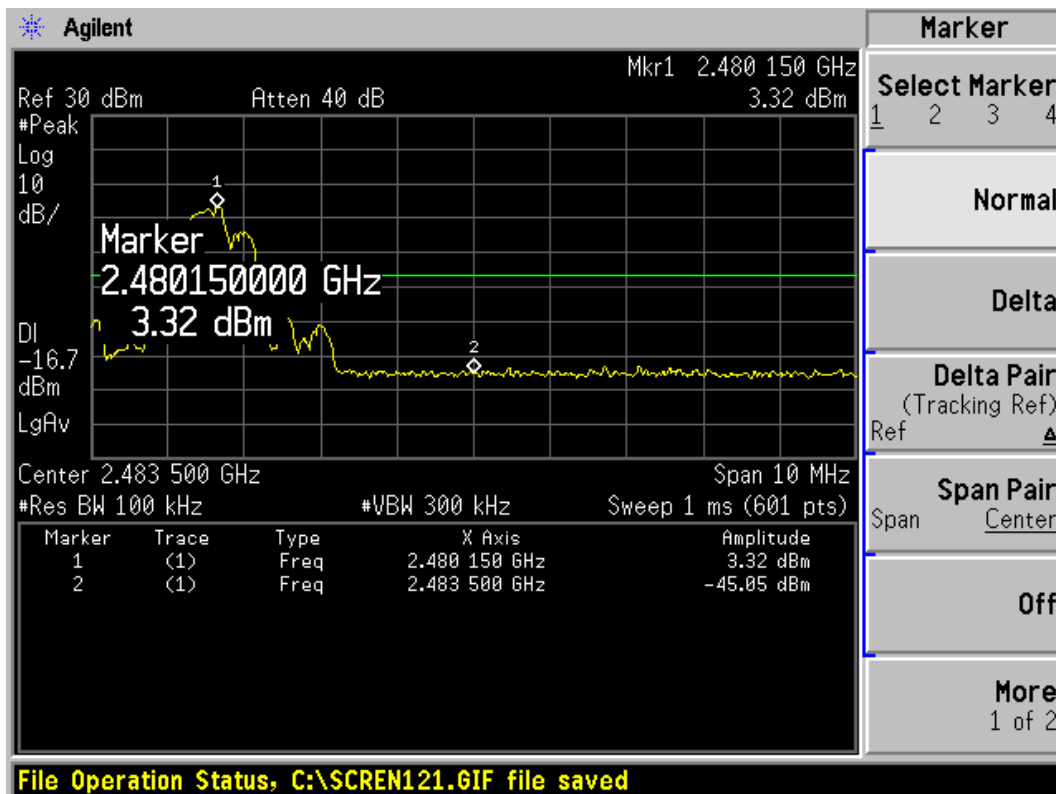

Carrier frequency (MHz): 2480
Channel No.:78

TA Technology (Shanghai) Co., Ltd.

Test Report

3.8. Spurious Radiated Emissions in the Restricted Band

Ambient condition

Temperature	Relative humidity	Pressure
23°C ~25°C	45%~50%	101.5kPa

The Equipment Under Test (EUT) was set up on a non-conductive table in the semi-anechoic chamber. The test was performed at the distance of 3 m between the EUT and the receiving antenna. The turntable shall be rotated from 0 to 360 degrees for detecting the maximum of radiated spurious signal level. The measurements shall be repeated with orthogonal polarization of the test antenna. The data of cable loss and antenna factor has been calibrated in full testing frequency range before the testing.

Set the spectrum analyzer in the following:

(a) PEAK: RBW=VBW=1MHz / Sweep=AUTO

(b) The dwell time per channel of the hopping signal is less than 100 ms, then the reading obtained with the 10 Hz VBW may be further adjusted by a “duty cycle correction factor”, derived from $20\log(\text{dwell time}/100 \text{ ms})$, in an effort to demonstrate compliance with the 15.209 limit.

If the emission is pulsed, modify the unit for continuous operation; use the settings shown above, then correct the reading by subtracting the peak- average correction factor, derived from the appropriate duty cycle calculation.

This setting method can refer to **DA00-705**.

The test is in transmitting mode. The field strength of spurious emission was measured in the following position: EUT stand-up position (Z axis), lie-down position (X, Y axis) and docking mode. The worst emission was found in stand-up position (Y axis) and the worst case was recorded.

Test setup

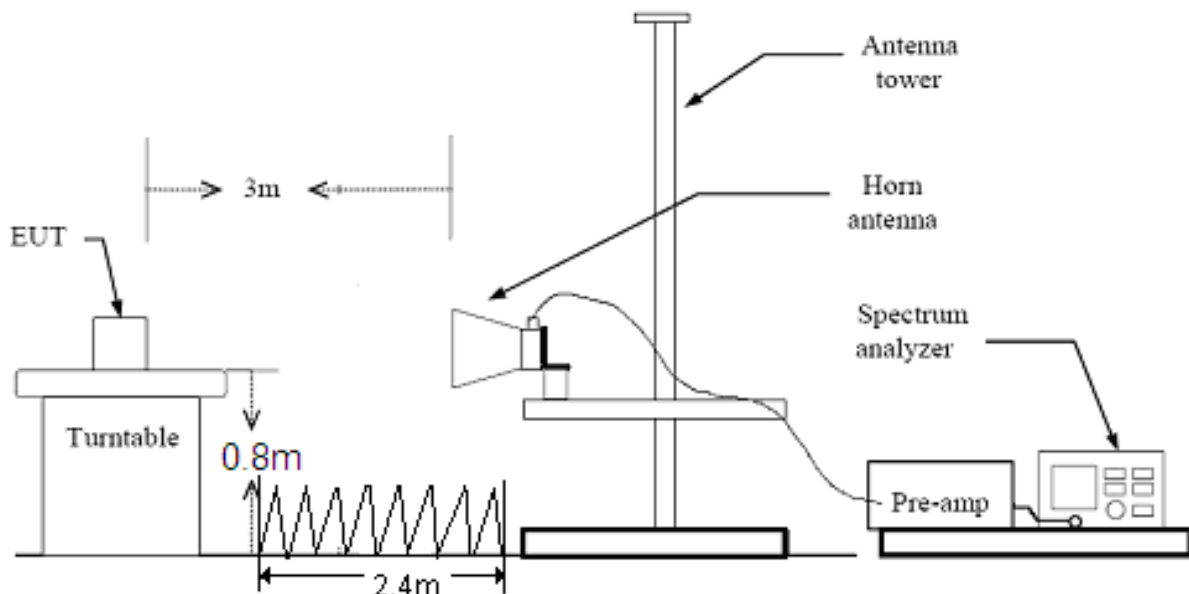

Note: Area side:2.4mX3.6m

TA Technology (Shanghai) Co., Ltd. Test Report

Report No.: RXA1407-0191RF03

Page 39 of 93

Limits

Spurious Radiated Emissions are permitted in any of the frequency bands listed below:

MHz	MHz	MHz	GHz
0.090 - 0.110	16.42 - 16.423	399.9 - 410	4.5 - 5.15
¹ 0.495 - 0.505	16.69475 - 16.69525	608 - 614	5.35 - 5.46
2.1735 - 2.1905	16.80425 - 16.80475	960 - 1240	7.25 - 7.75
4.125 - 4.128	25.5 - 25.67	1300 - 1427	8.025 - 8.5
4.17725 - 4.17775	37.5 - 38.25	1435 - 1626.5	9.0 - 9.2
4.20725 - 4.20775	73 - 74.6	1645.5 - 1646.5	9.3 - 9.5
6.215 - 6.218	74.8 - 75.2	1660 - 1710	10.6 - 12.7
6.26775 - 6.26825	108 - 121.94	1718.8 - 1722.2	13.25 - 13.4
6.31175 - 6.31225	123 - 138	2200 - 2300	14.47 - 14.5
8.291 - 8.294	149.9 - 150.05	2310 - 2390	15.35 - 16.2
8.362 - 8.366	156.52475 - 156.52525	2483.5 - 2500	17.7 - 21.4
8.37625 - 8.38675	156.7 - 156.9	2690 - 2900	22.01 - 23.12
8.41425 - 8.41475	162.0125 - 167.17	3260 - 3267	23.6 - 24.0
12.29 - 12.293	167.72 - 173.2	3332 - 3339	31.2 - 31.8
12.51975 - 12.52025	240 - 285	3345.8 - 3358	36.43 - 36.5
12.57675 - 12.57725	322 - 335.4	3600 - 4400	(²)
13.36 - 13.41			

Limit in restricted band

Frequency of emission (MHz)	Field strength(uV/m)	Field strength(dBuV/m)
30-88	100	40
88-216	150	43.5
216-960	200	46
Above960	500	54

§15.35(b)

There is also a limit on the radio frequency emissions, as measured using instrumentation with a peak detector function, corresponding to 20 dB above the maximum permitted average limit.

Peak Limit=74 dBuV/m

Average Limit=54 dBuV/m

Measurement Uncertainty

The assessed measurement uncertainty to ensure 95% confidence level for the normal distribution is with the coverage factor $k = 1.96$, $U = 3.55$ dB.

TA Technology (Shanghai) Co., Ltd. Test Report

Report No.: RXA1407-0191RF03

Page 40 of 93

Test Results:

DH5- Channel 0

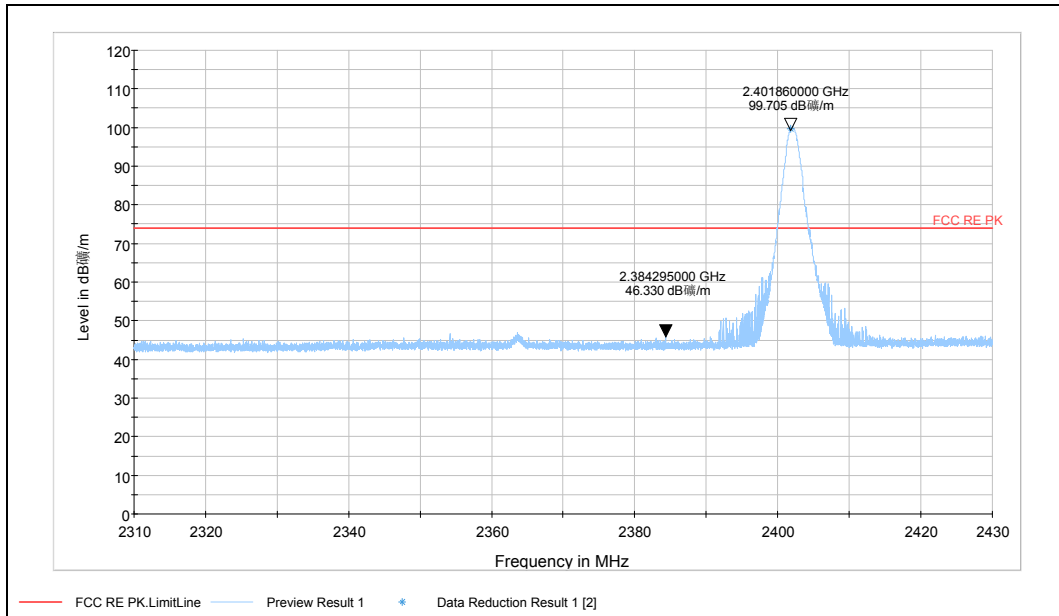

lower band edge Peak-CH 0

Note: The signal beyond the limit is carrier, a font (Level in dB μ V/m) in the test plot =(level in dBuV/m)

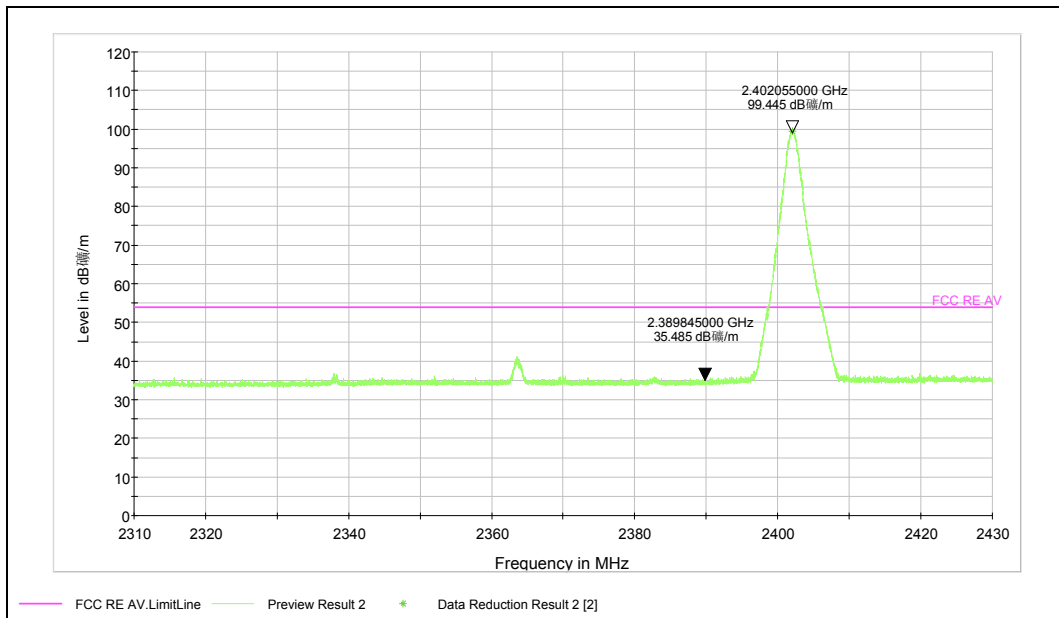

lower band edge average-CH 0

Note: The signal beyond the limit is carrier, a font (Level in dB μ V/m) in the test plot =(level in dBuV/m)

TA Technology (Shanghai) Co., Ltd. Test Report

Report No.: RXA1407-0191RF03

Page 41 of 93

DH5- Channel 78

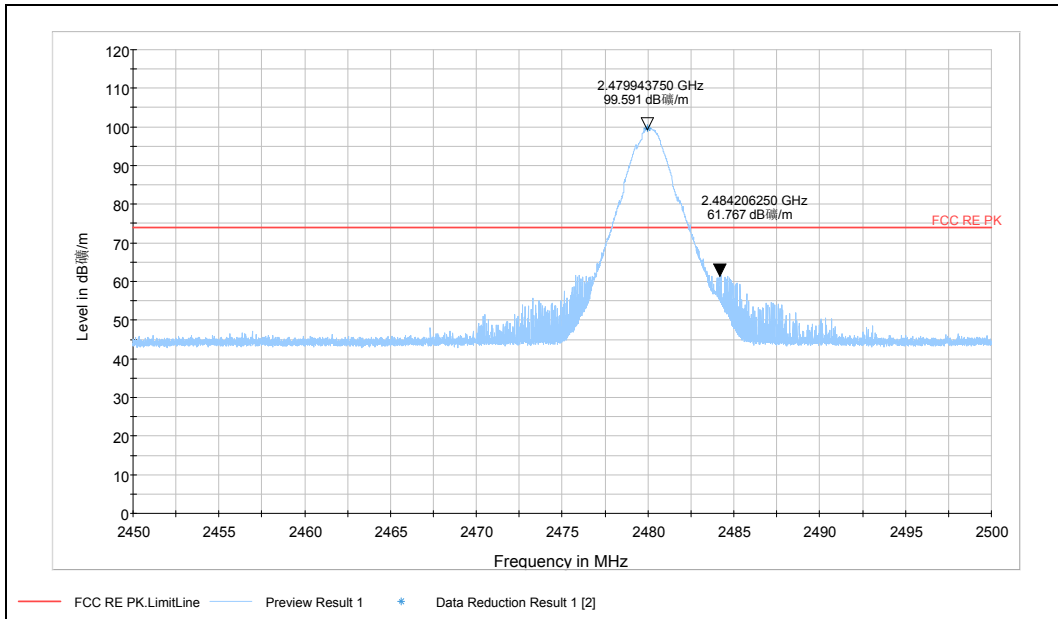

Higher band edge Peak-CH 78

Note: The signal beyond the limit is carrier, a font (Level in dB μ V/m) in the test plot =(level in dBuV/m)

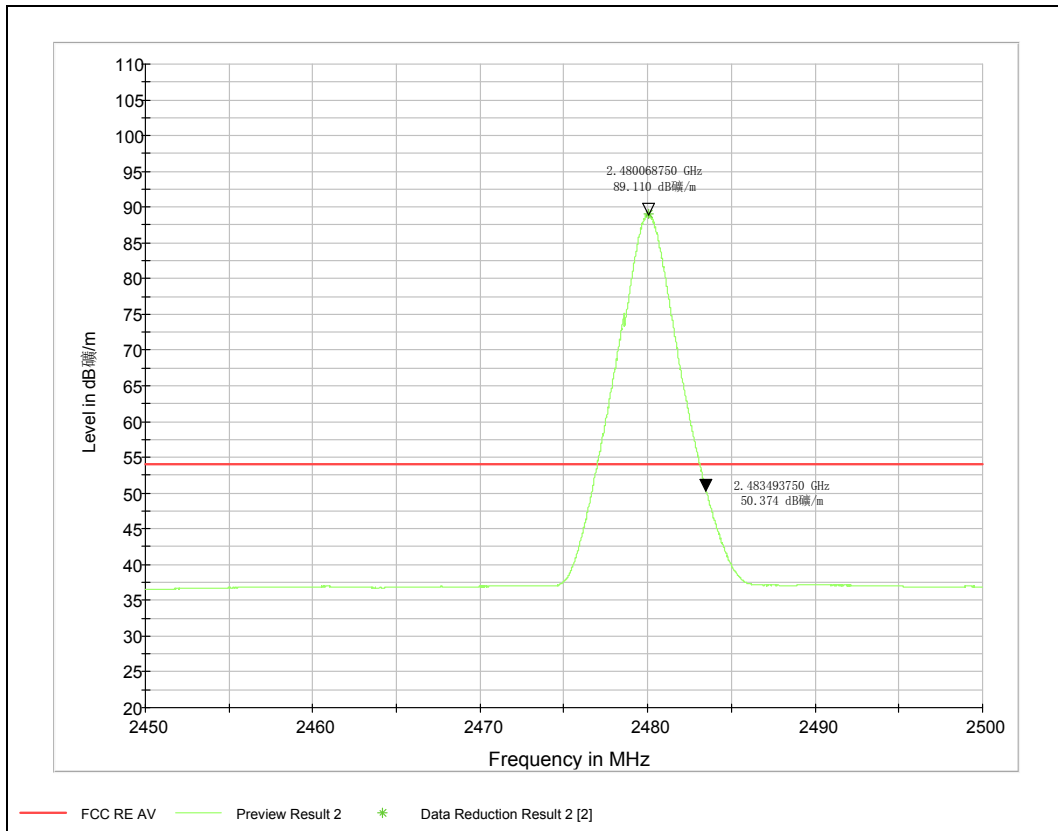

Higher band edge average-CH 78

Note: The signal beyond the limit is carrier, a font (Level in dB μ V/m) in the test plot =(level in dBuV/m)

TA Technology (Shanghai) Co., Ltd. Test Report

Report No.: RXA1407-0191RF03

Page 42 of 93

3DH5- Channel 0

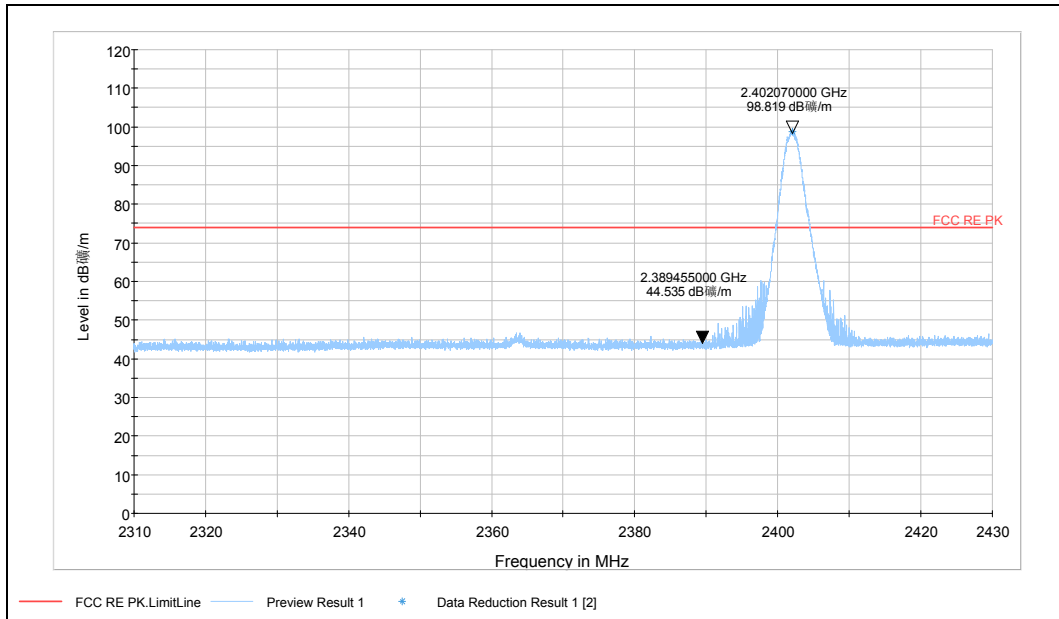

lower band edge Peak-CH 0

Note: The signal beyond the limit is carrier, a font (Level in dB μ V/m) in the test plot =(level in dBuV/m)

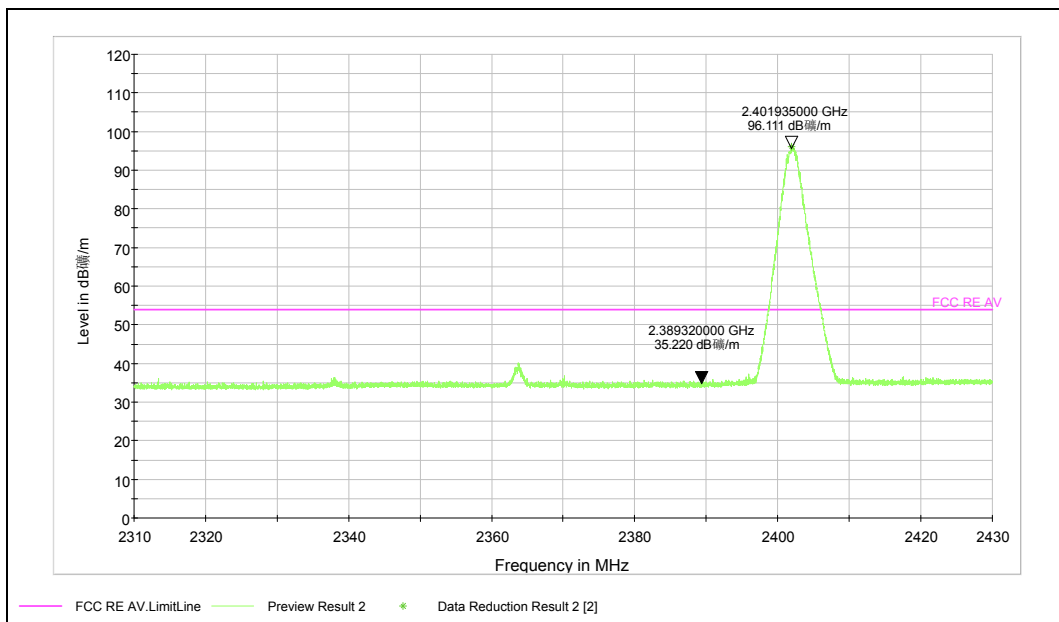

lower band edge average-CH 0

Note: The signal beyond the limit is carrier, a font (Level in dB μ V/m) in the test plot =(level in dBuV/m)

3DH5- Channel 78

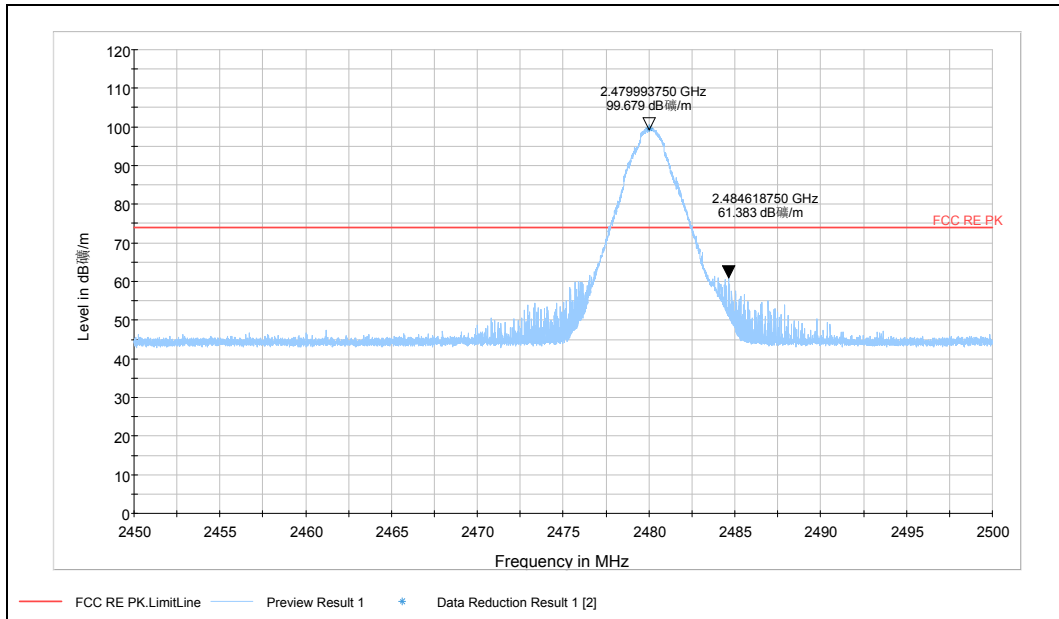

Higher band edge Peak-CH 78

Note: The signal beyond the limit is carrier, a font (Level in dBμV/m) in the test plot =(level in dBuV/m)

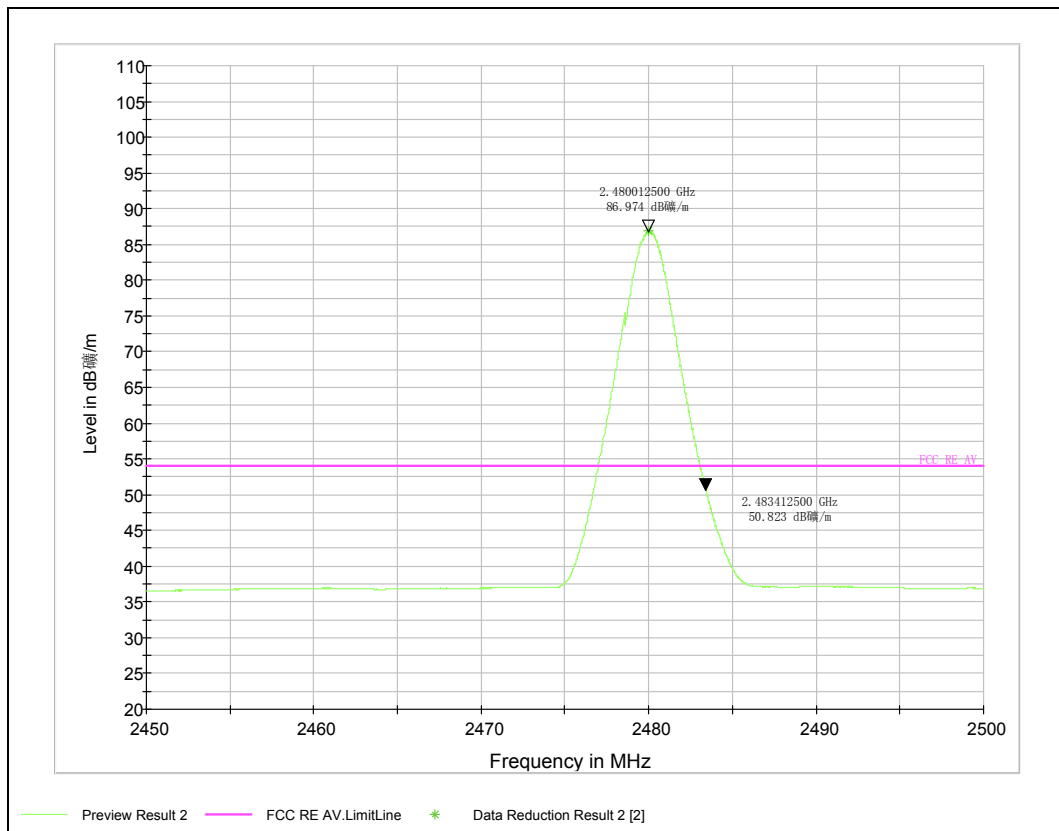

Higher band edge average-CH 78

Note: The signal beyond the limit is carrier, a font (Level in dBμV/m) in the test plot =(level in dBuV/m)

TA Technology (Shanghai) Co., Ltd.

Test Report

Report No.: RXA1407-0191RF03

Page 44 of 93

3.9. Number of hopping Frequency

Ambient condition

Temperature	Relative humidity	Pressure
23°C ~25°C	45%~50%	101.5kPa

Method of Measurement

The EUT was connected to the spectrum analyzer and Bluetooth test set via a power splitter with a known loss. RBW is set to 300kHz and VBW is set to 300kHz on spectrum analyzer. Set EUT on Hopping on mode.

Test setup

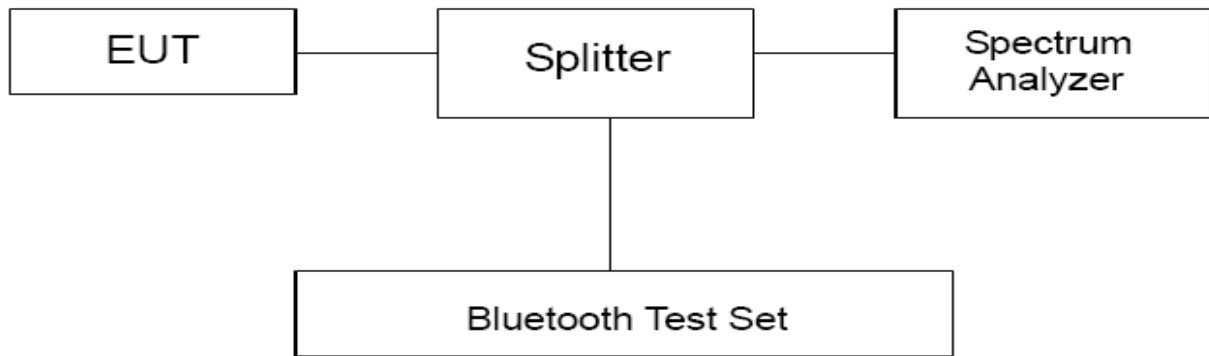

Limits

Rule Part 15.247(a) (1) (iii) specifies that "Frequency hopping systems in the 2400–2483.5 MHz band shall use at least 15 channels..".

Limits	≥ 15 channels
--------	--------------------

TA Technology (Shanghai) Co., Ltd. Test Report

Report No.: RXA1407-0191RF03

Page 45 of 93

Test Results:

DH5

Number of hopping channels	conclusion
79	PASS

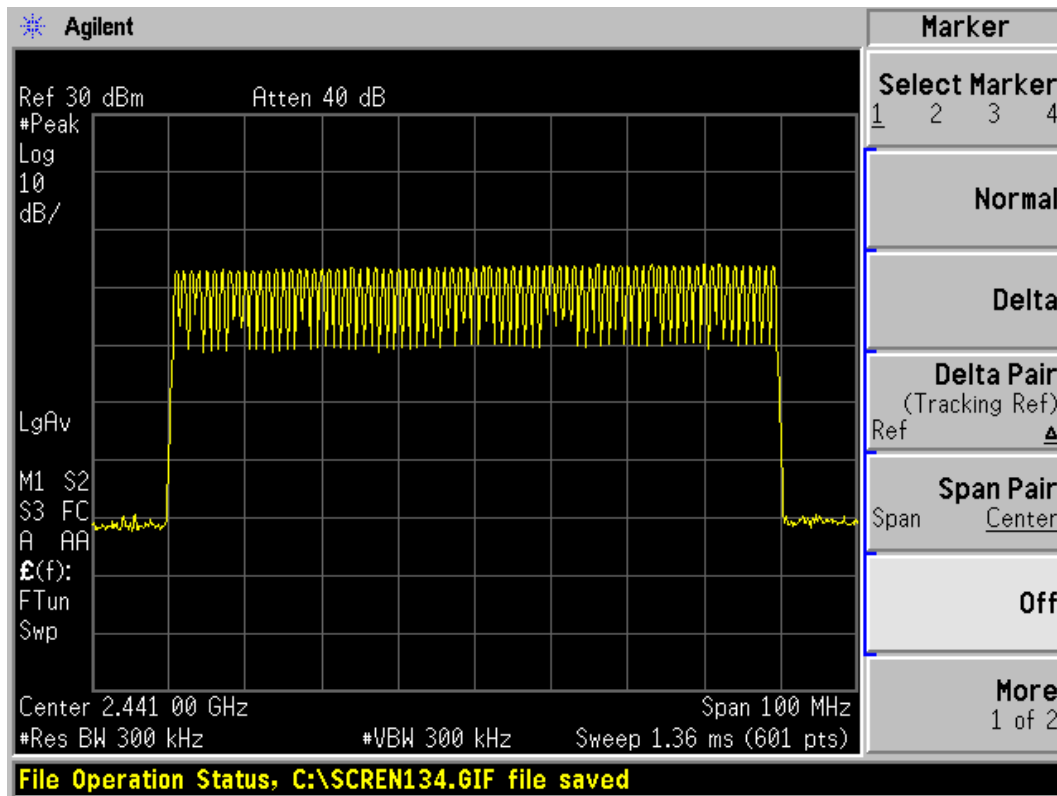

2400 MHz – 2483.5 MHz

TA Technology (Shanghai) Co., Ltd. Test Report

2DH5

Number of hopping channels	conclusion
79	PASS

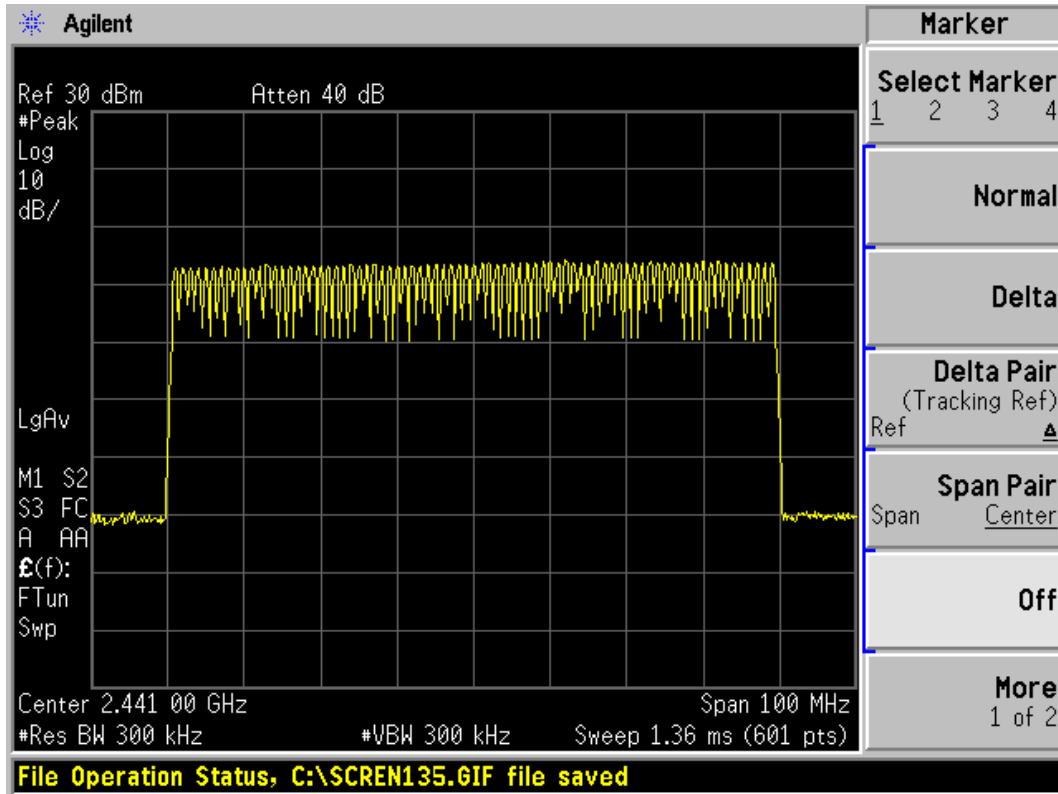

2400 MHz – 2483.5 MHz

TA Technology (Shanghai) Co., Ltd. Test Report

3DH5

Number of hopping channels	conclusion
79	PASS

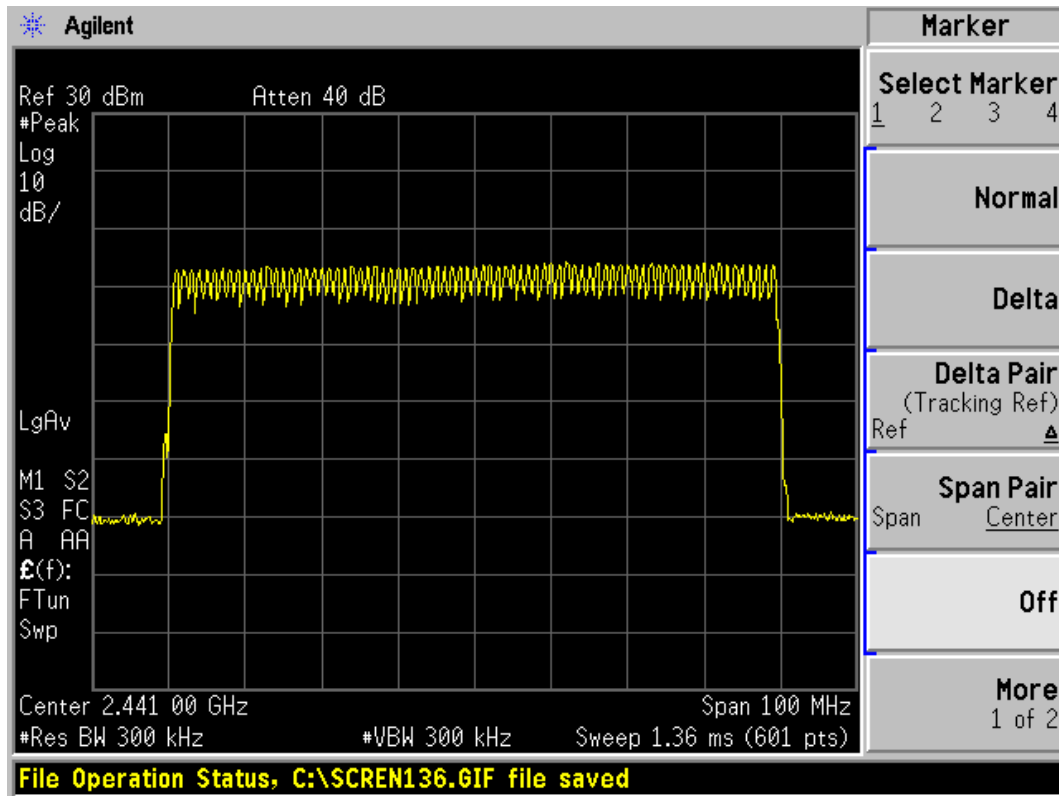

2400 MHz – 2483.5 MHz

TA Technology (Shanghai) Co., Ltd.

Test Report

3.10. Spurious RF Conducted Emissions

Ambient condition

Temperature	Relative humidity	Pressure
23°C ~25°C	45%~50%	101.5kPa

Method of Measurement

The EUT was connected to the spectrum analyzer and Bluetooth test set via a power splitter with a known loss. The spectrum analyzer scans from 30MHz to the 10th harmonic of the carrier. The peak detector is used. RBW and VBW are set to 100 kHz, Sweep is set to ATUO.

The test is in transmitting mode.

Test setup

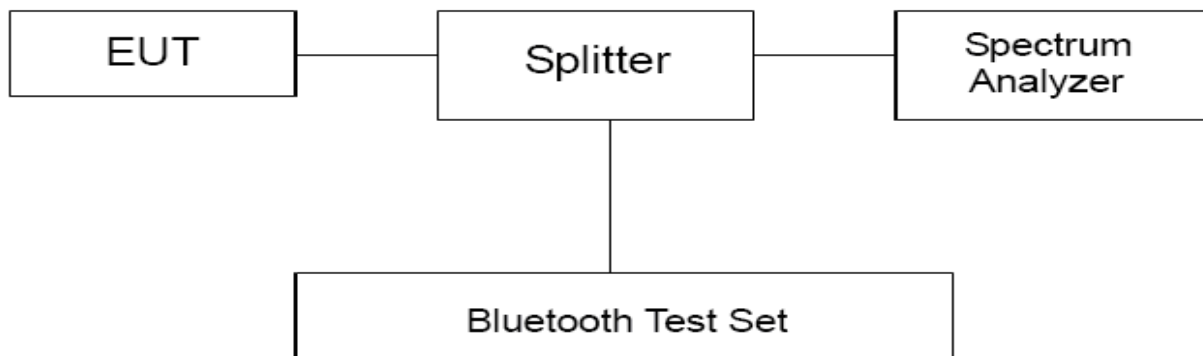

Limits

Rule Part 15.247(d) specifies that “In any 100 kHz bandwidth outside the frequency band in which the spread spectrum intentional radiator is operating, the radio frequency power that is produced by the intentional radiator shall be at least 20 dB below that in the 100 kHz bandwidth within the band that contains the highest level of the desired power.”

Mode	Carrier frequency (MHz)	Reference value (dBm)	Limit
DH5	2402	2.02	≤-17.98
	2441	2.67	≤-17.33
	2480	3.04	≤-16.96
EDR (3DH5)	2402	1.55	≤-18.45
	2441	2.10	≤-17.90
	2480	2.05	≤-17.95

TA Technology (Shanghai) Co., Ltd.

Test Report

Report No.: RXA1407-0191RF03

Page 49 of 93

Measurement Uncertainty

The assessed measurement uncertainty to ensure 95% confidence level for the normal distribution is with the coverage factor $k = 1.96$.

Frequency	Uncertainty
100kHz-2GHz	0.684 dB
2GHz-26GHz	1.407 dB

TA Technology (Shanghai) Co., Ltd. Test Report

Report No.: RXA1407-0191RF03

Page 50 of 93

Test Results:

DH5-CH0:

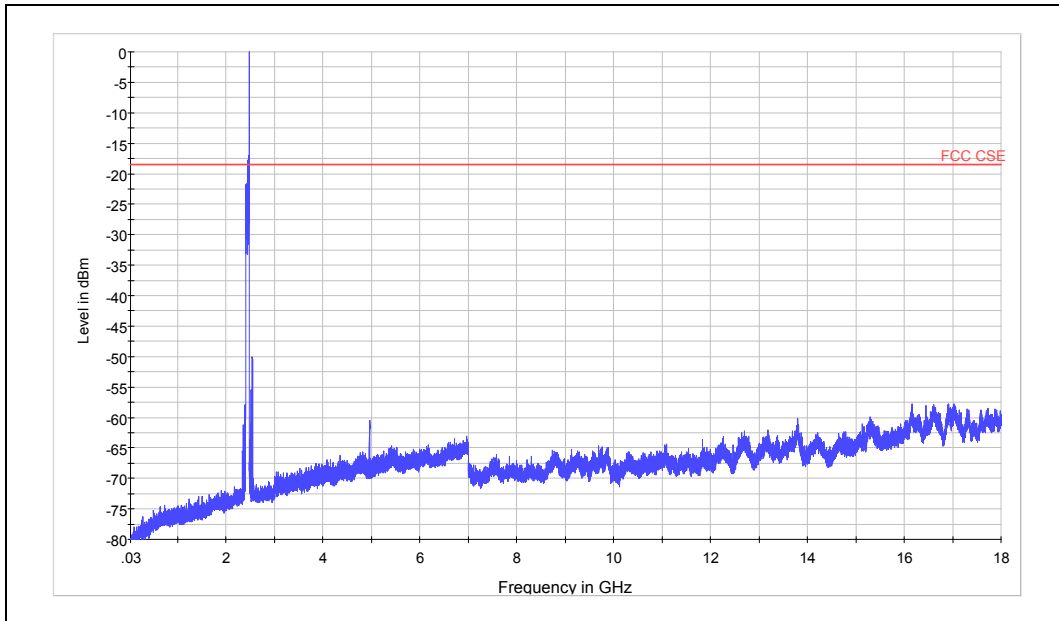

Note: The signal beyond the limit is carrier. Carrier frequency (MHz): 2402
Spurious RF conducted emissions from 30MHz to 18GHz

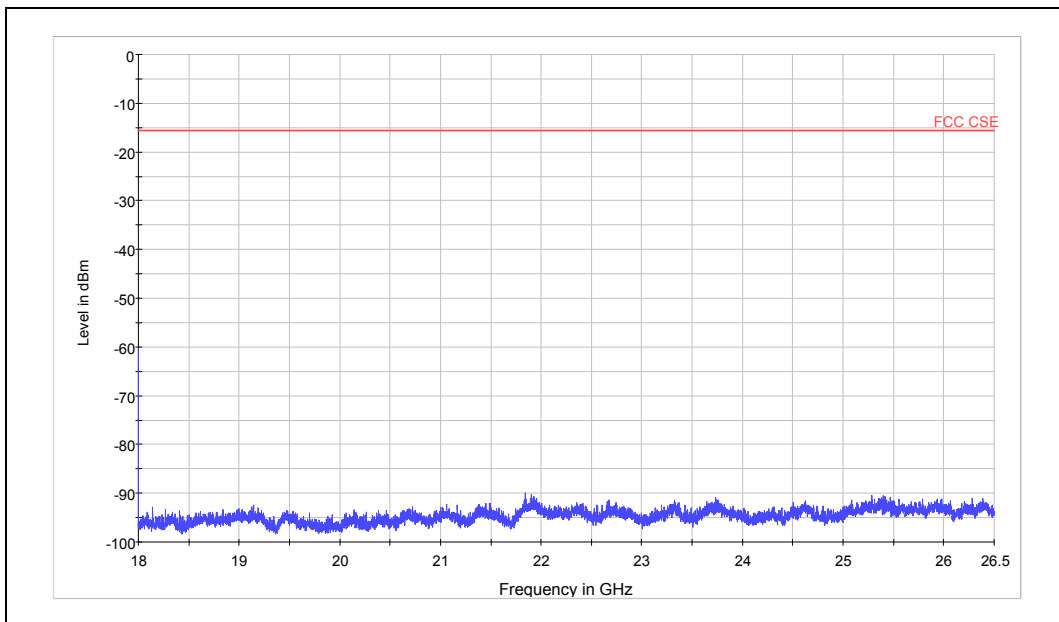

Spurious RF conducted emissions from 18GHz to 26.5GHz

TA Technology (Shanghai) Co., Ltd. Test Report

Report No.: RXA1407-0191RF03

Page 51 of 93

DH5-CH39:

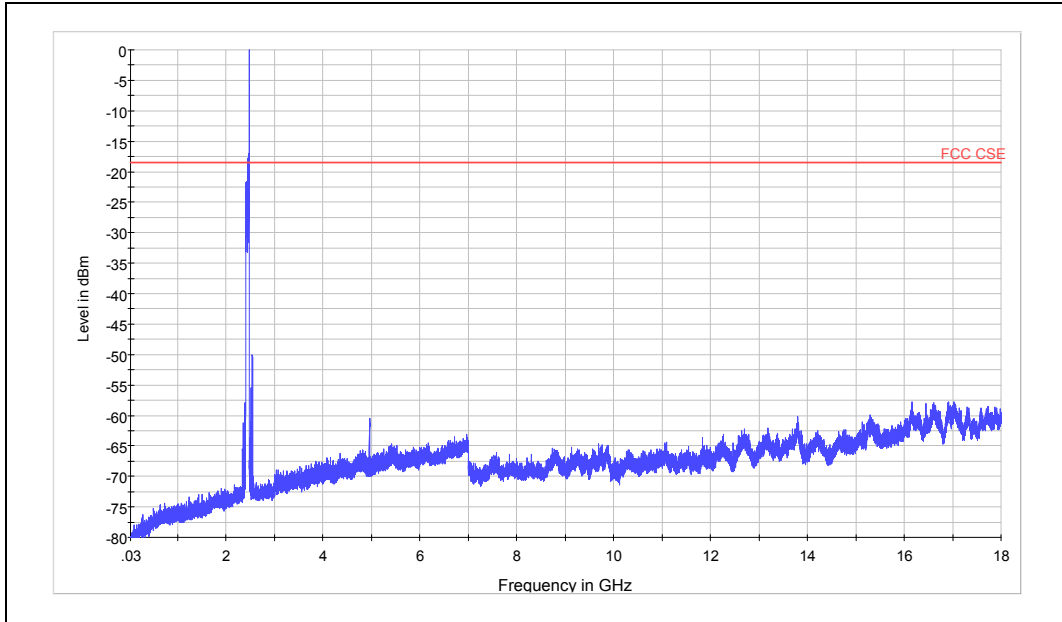

Note: The signal beyond the limit is carrier. Carrier frequency (MHz): 2441
Spurious RF conducted emissions from 30MHz to 18GHz

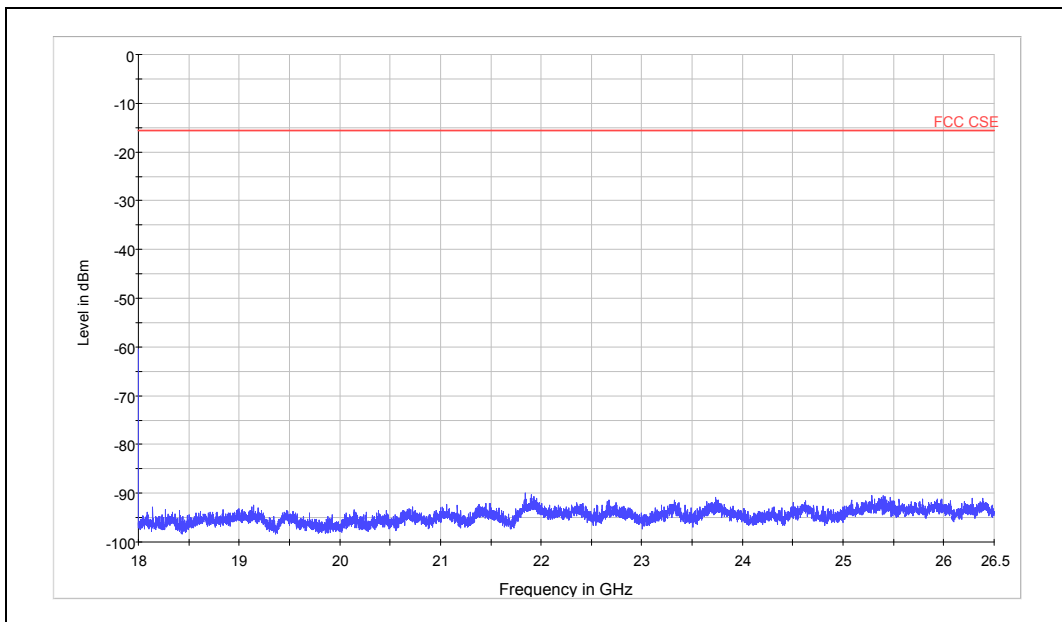

Spurious RF conducted emissions from 18GHz to 26.5GHz

TA Technology (Shanghai) Co., Ltd. Test Report

Report No.: RXA1407-0191RF03

Page 52 of 93

DH5-CH78:

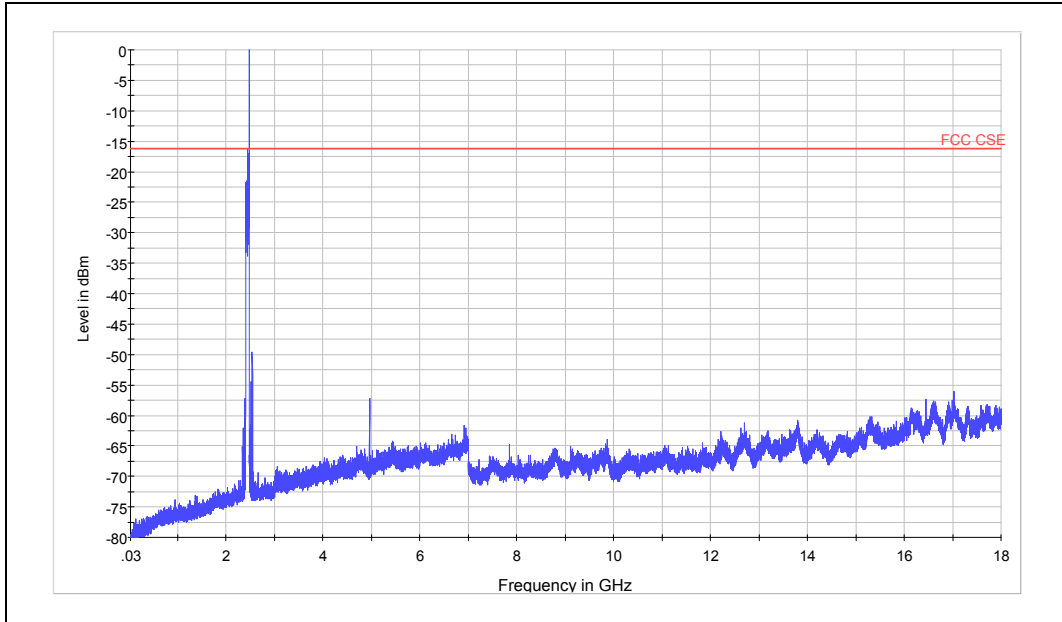

Note: The signal beyond the limit is carrier. Carrier frequency (MHz): 2480
Spurious RF conducted emissions from 30MHz to 18GHz

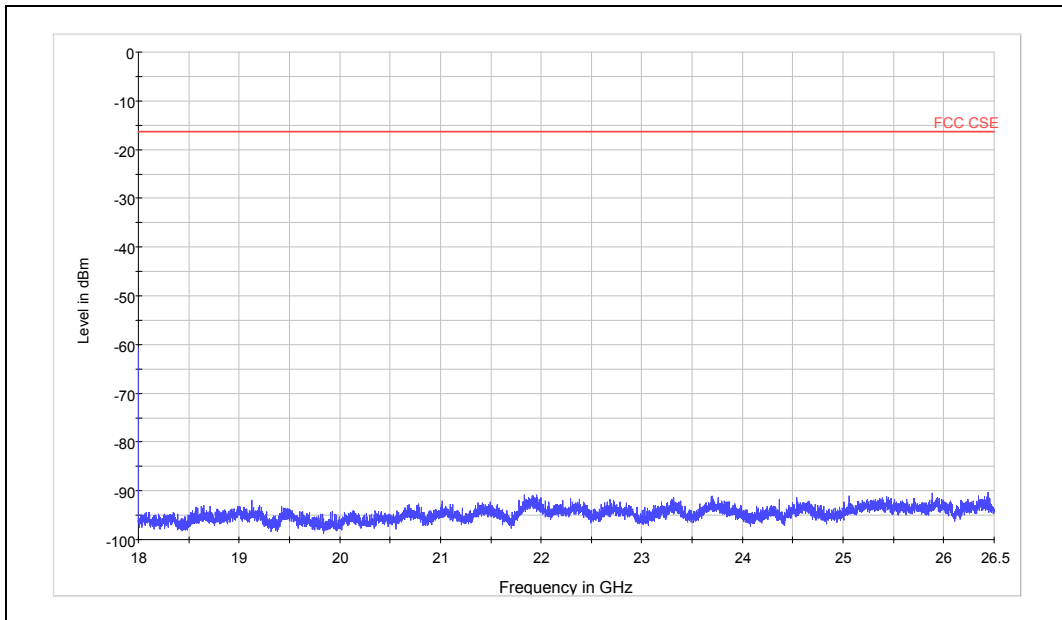

Spurious RF conducted emissions from 18GHz to 26.5GHz

TA Technology (Shanghai) Co., Ltd. Test Report

Report No.: RXA1407-0191RF03

Page 53 of 93

3DH5-CH0:

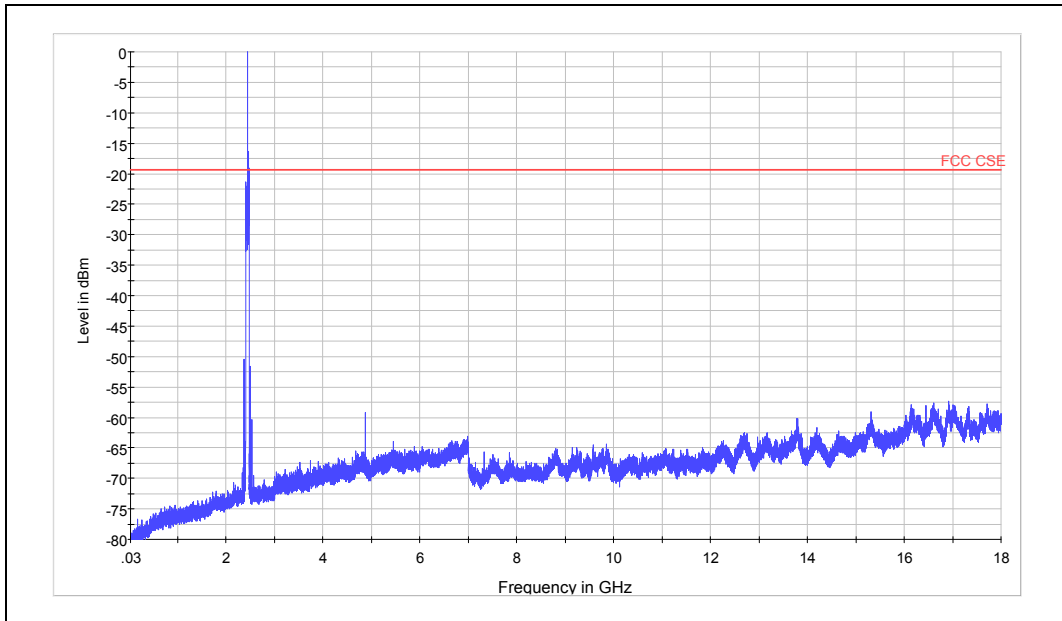

Note: The signal beyond the limit is carrier. Carrier frequency (MHz): 2402
Spurious RF conducted emissions from 30MHz to 18GHz

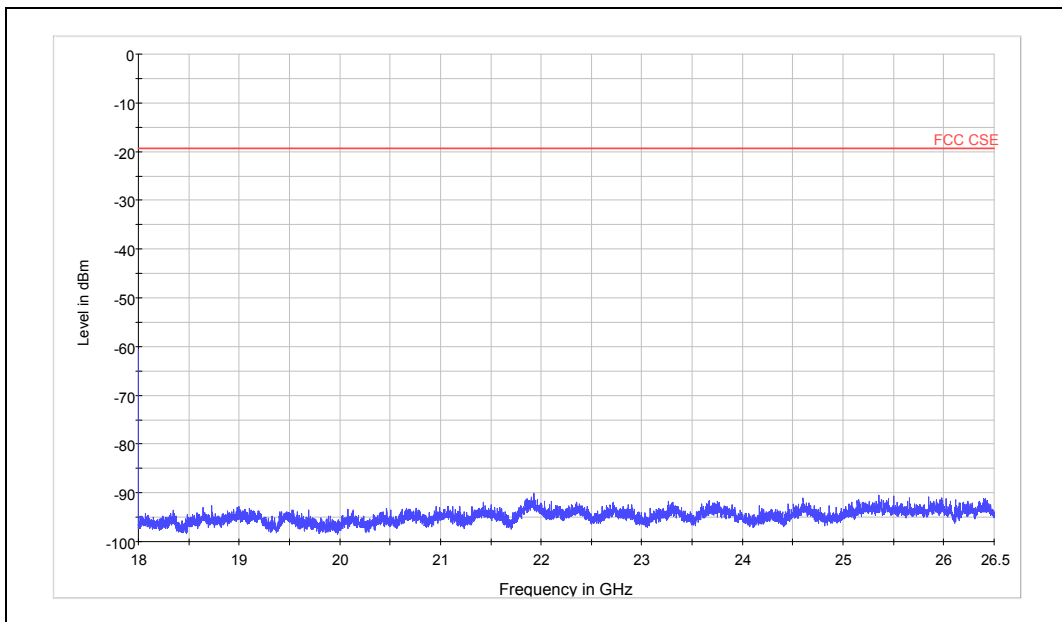

Spurious RF conducted emissions from 18GHz to 26.5GHz

TA Technology (Shanghai) Co., Ltd. Test Report

Report No.: RXA1407-0191RF03

Page 54 of 93

3DH5 -CH39:

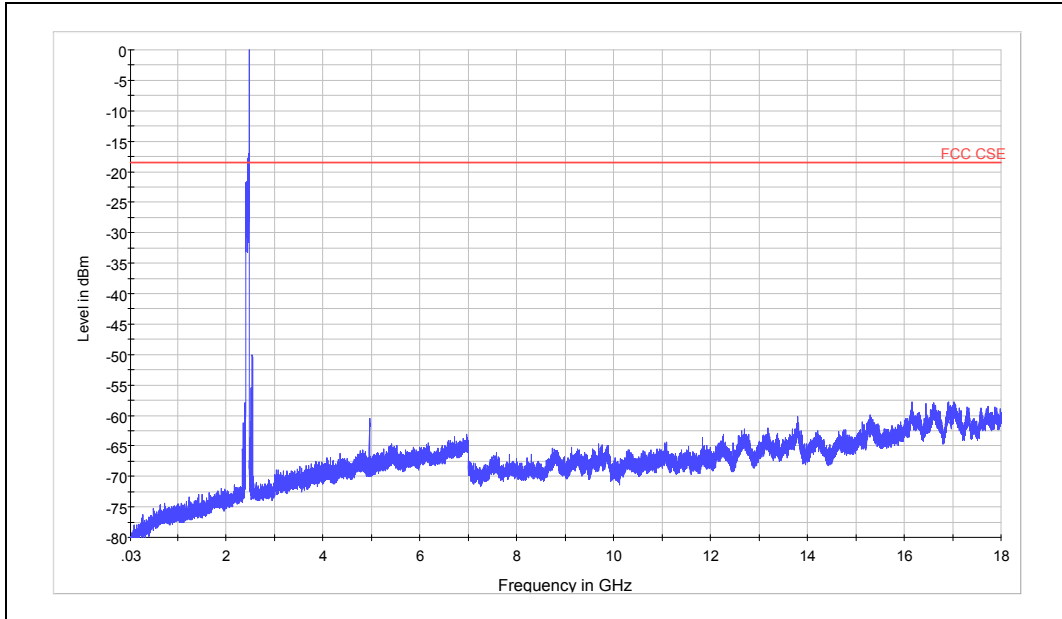

Note: The signal beyond the limit is carrier. Carrier frequency (MHz): 2441
Spurious RF conducted emissions from 30MHz to 18GHz

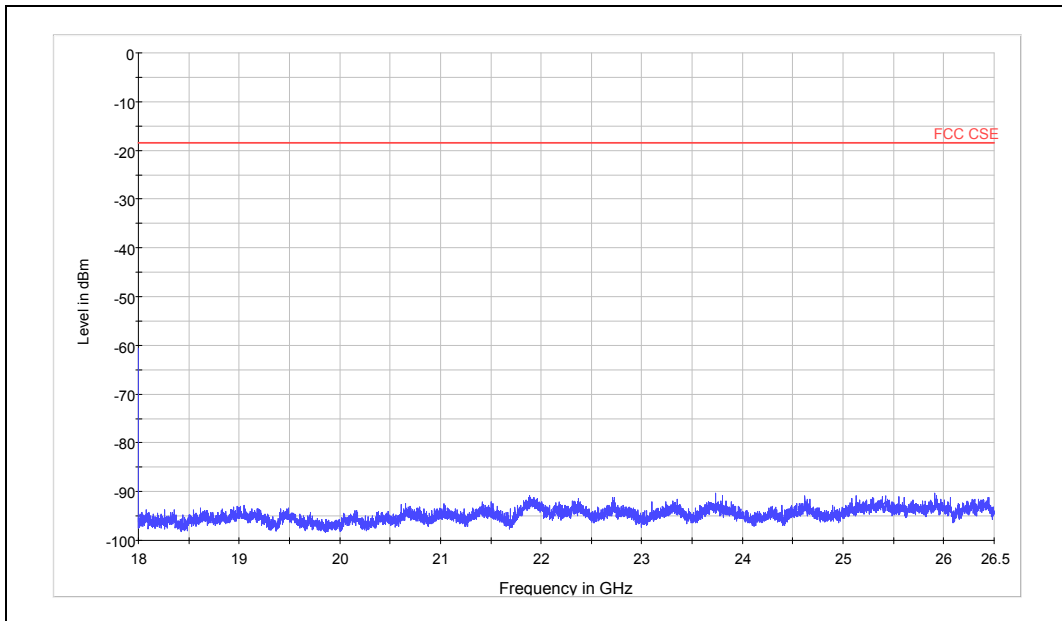

Spurious RF conducted emissions from 18GHz to 26.5GHz

TA Technology (Shanghai) Co., Ltd. Test Report

Report No.: RXA1407-0191RF03

Page 55 of 93

3DH5 -CH78:

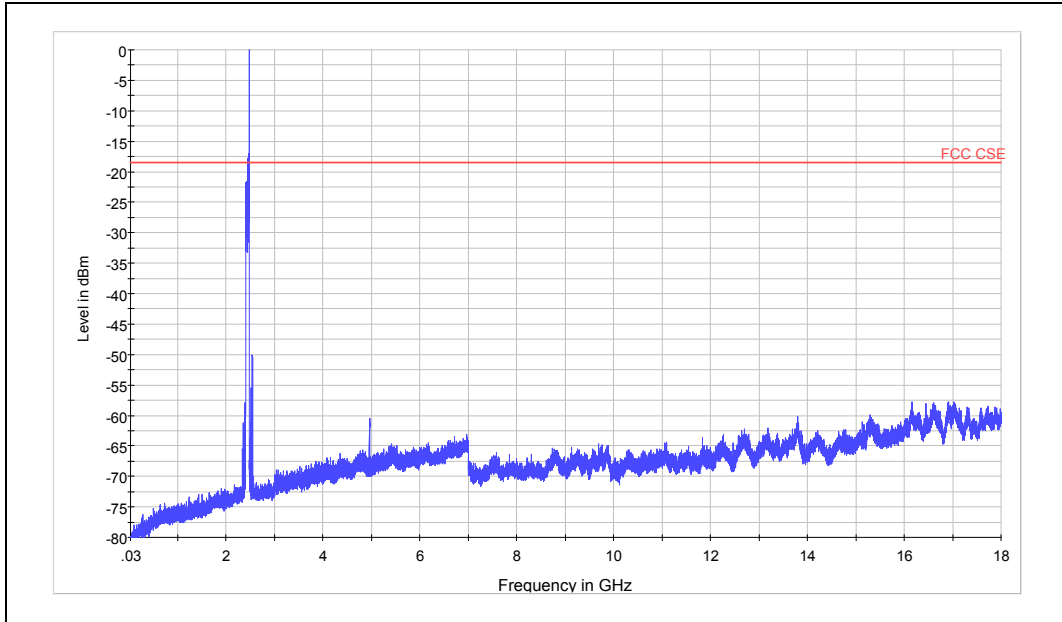

Note: The signal beyond the limit is carrier. Carrier frequency (MHz): 2480
Spurious RF conducted emissions from 30MHz to 18GHz

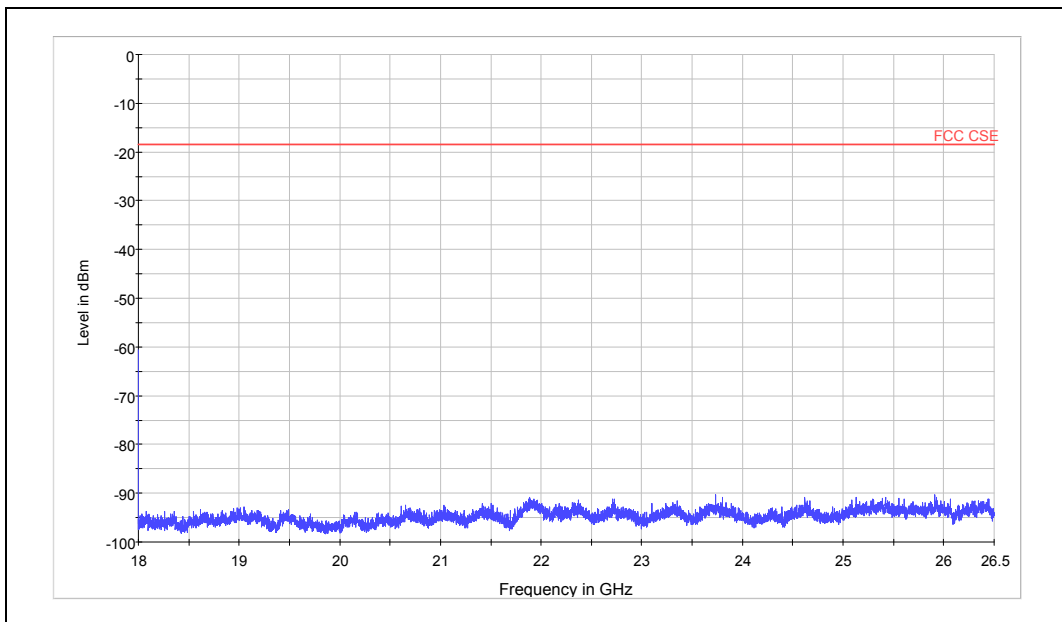

Spurious RF conducted emissions from 18GHz to 26.5GHz

TA Technology (Shanghai) Co., Ltd.

Test Report

3.11. Radiates Emission

Ambient condition

Temperature	Relative humidity	Pressure
23°C ~25°C	45%~50%	102.5kPa

Method of Measurement

The test set-up was made in accordance to the general provisions of ANSI C63.4-2009. The Equipment Under Test (EUT) was set up on a non-conductive table in the semi-anechoic chamber. The test was performed at the distance of 3 m between the EUT and the receiving antenna. The radiated emissions measurements were made in a typical installation configuration.

Sweep the whole frequency band through the range from 9 kHz to the 10th harmonic of the carrier, and the emissions less than 20 dB below the permissible value are reported.

The height of receive antenna shall be moved from 1 to 4 meters, and the antenna shall be performed under horizontal and vertical polarization. The turntable shall be rotated from 0 to 360 degrees for detecting the maximum of radiated spurious signal level. The measurements shall be repeated with orthogonal polarization of the test antenna. The data of cable loss and antenna factor has been calibrated in full testing frequency range before the testing.

Set the spectrum analyzer in the following:

Below 1GHz (detector: Peak and Quasi-Peak)

RBW=100kHz / VBW=300kHz / Sweep=AUTO

Above 1GHz(detector: Peak):

(a) PEAK: RBW=1MHz VBW=3MHz/ Sweep=AUTO

(b) AVERAGE: RBW=1MHz / VBW=10Hz / Sweep=AUTO

The radiated emission was measured in the following position: EUT stand-up position (Z axis), lie-down position (X, Y axis). The worst emission was found in stand-up position (Z axis) and the worst case was recorded. Then this mode was measured in the following mode: EUT with cradle and EUT without cradle. The worst emission was found in EUT with cradle mode and the worst case was recorded.

The test is in transmitting mode.

TA Technology (Shanghai) Co., Ltd. Test Report

Report No.: RXA1407-0191RF03

Page 57 of 93

Test setup

9KHz~~~ 30MHz

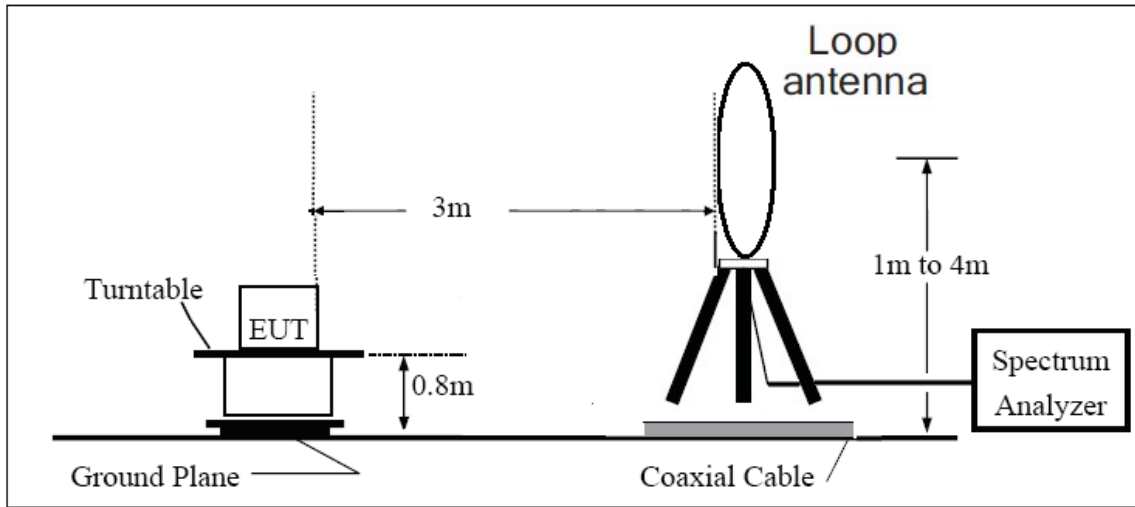

30MHz~~~ 1GHz

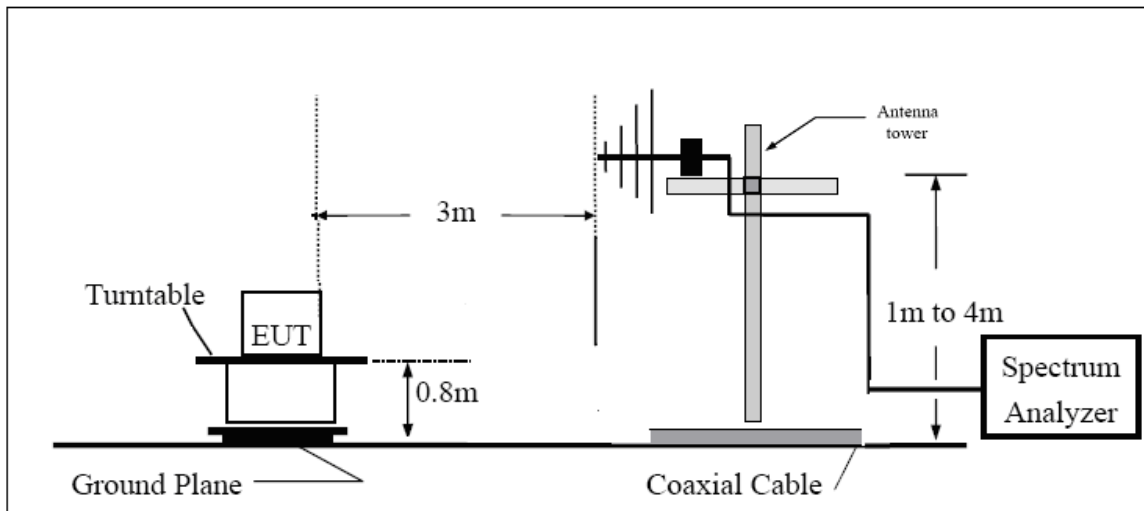

Above 1GHz

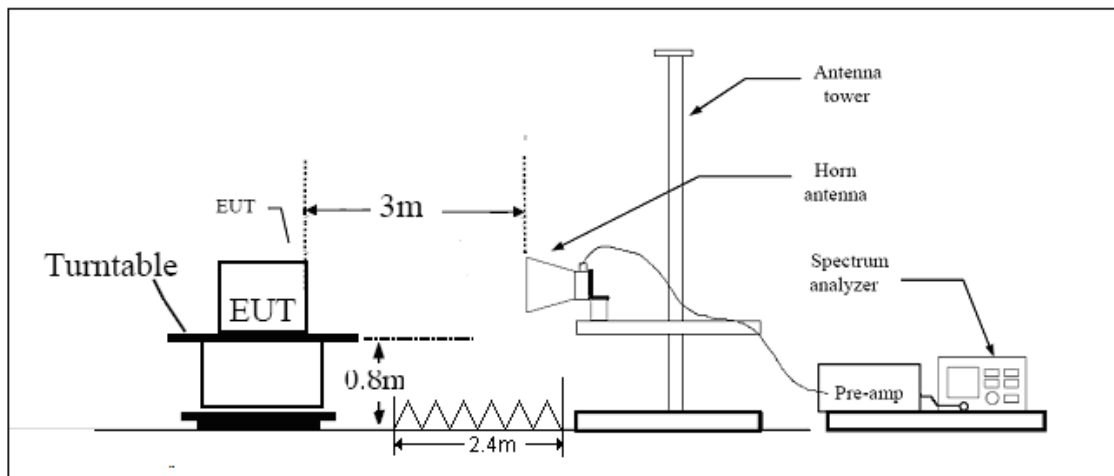

TA Technology (Shanghai) Co., Ltd. Test Report

Report No.: RXA1407-0191RF03

Page 58 of 93

Limits

Rule Part 15.247(d) specifies that “In addition, radiated emissions which fall in the restricted bands, as defined in § 15.205(a), must also comply with the radiated emission limits specified in § 15.209(a) (see § 15.205(c)).”

Limit in restricted band

Frequency of emission (MHz)	Field strength(uV/m)	Field strength(dBuV/m)
0.009–0.490	2400/F(kHz)	/
0.490–1.705	24000/F(kHz)	/
1.705–30.0	30	/
30-88	100	40
88-216	150	43.5
216-960	200	46
Above960	500	54

§15.35(b)

There is also a limit on the radio frequency emissions, as measured using instrumentation with a peak detector function, corresponding to 20 dB above the maximum permitted average limit.

Measurement Uncertainty

The assessed measurement uncertainty to ensure 95% confidence level for the normal distribution is with the coverage factor $k = 1.96$.

Frequency	Uncertainty
9KHz-30MHz	3.55 dB
30MHz-200MHz	4.19 dB
200MHz-1GHz	3.63 dB
Above 1GHz	3.68 dB

TA Technology (Shanghai) Co., Ltd. Test Report

Test result

DH5-Channel 0

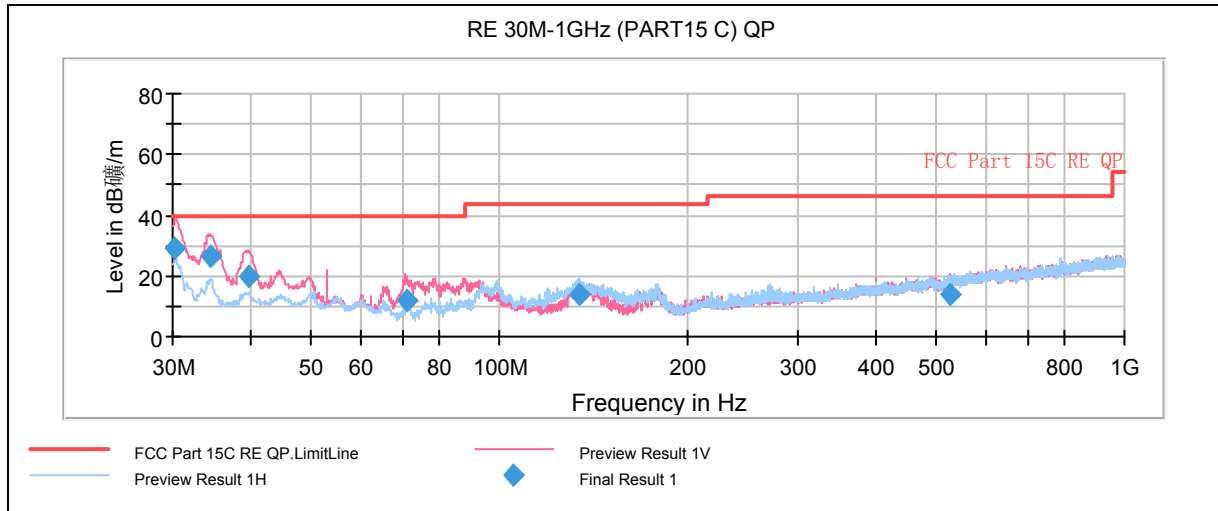

Note: This graph displays the maximum values of horizontal and vertical by software

Note: a font (Level in dBµV/m) in the test plot =(level in dBuV/m)

Radiates Emission from 30MHz to 1GHz

Frequency (MHz)	Quasi-Peak (dBuV/m)	Height (cm)	Polarization	Azimuth (deg)	Reading value (dBuV/m)	Correct Factor (dB)	Margin (dB)	Limit (dBuV/m)
30.260000	28.8	100.0	V	299.0	46.0	-17.2	11.2	40.0
34.506250	26.7	100.0	V	169.0	45.7	-19.0	13.3	40.0
39.596250	20.0	124.0	V	309.0	39.3	-19.3	20.0	40.0
71.158750	11.7	100.0	V	16.0	39.5	-27.8	28.3	40.0
134.332500	13.8	223.0	H	99.0	42.7	-28.9	29.7	43.5
525.120000	14.1	200.0	V	296.0	31.9	-17.8	31.9	46.0

Remark: 1. Quasi-Peak = Reading value + Correction factor

2. Correction Factor = Antenna factor+ Insertion loss(cable loss+amplifier gain)

3. Margin = Limit – Quasi-Peak

TA Technology (Shanghai) Co., Ltd. Test Report

Report No.: RXA1407-0191RF03

Page 60 of 93

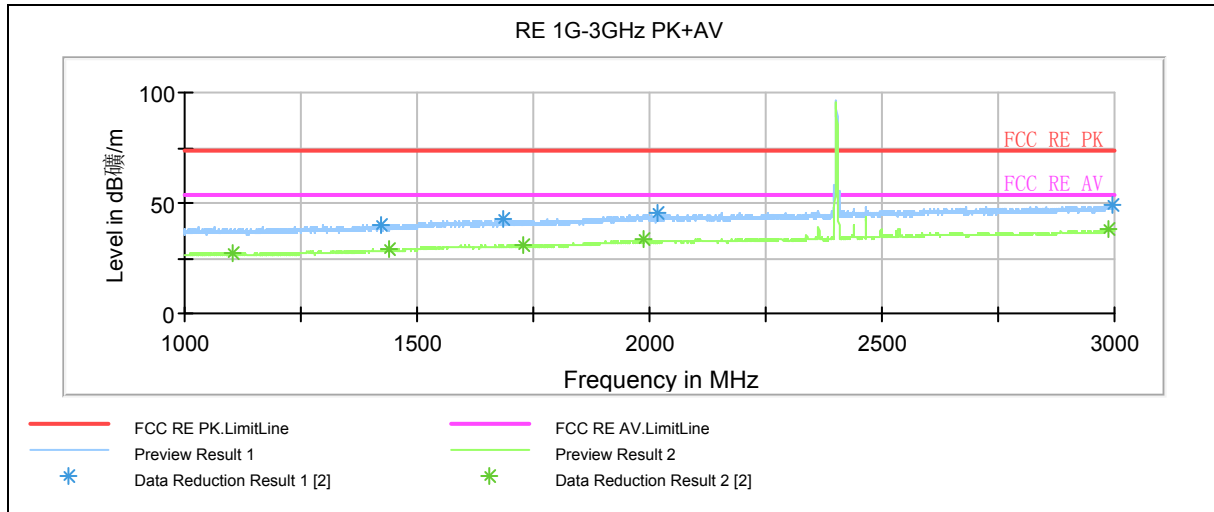

Radiates Emission from 1GHz to 3GHz

Note: The signal beyond the limit is carrier.

Note: This graph displays the maximum values of horizontal and vertical by software

Note: The signal beyond the limit is carrier. a font (Level in dB μ V/m) in the test plot =(level in dBuV/m)

Frequency (MHz)	Peak (dBuV/m)	Height (cm)	Polarization	Azimuth (deg)	Reading value (dBuV/m)	Correct Factor (dB)	Margin (dB)	Limit (dBuV/m)
1421.750000	40.4	100.0	H	93.0	48.5	-8.1	33.6	74
1683.750000	42.3	100.0	V	332.0	47.9	-5.6	31.7	74
2017.250000	45.2	100.0	H	273.0	48.4	-3.2	28.8	74
2996.000000	49.5	100.0	V	274.0	50.9	-1.4	24.5	74

Remark: 1. Correction Factor = Antenna factor+ Insertion loss (cable loss + amplifier gain)

Frequency (MHz)	Average (dBuV/m)	Height (cm)	Polarization	Azimuth (deg)	Reading value (dBuV/m)	Correct Factor (dB)	Margin (dB)	Limit (dBuV/m)
1103.250000	27.5	100.0	H	78.0	37.5	-10.0	26.5	54
1441.000000	28.8	100.0	V	0.0	36.8	-8.0	25.2	54
1730.500000	30.9	100.0	V	339.0	36.5	-5.6	23.1	54
1988.250000	33.2	100.0	H	4.0	36.4	-3.2	20.8	54
2988.250000	38.0	100.0	V	153.0	39.4	-1.4	16.0	54

Remark: 1. Correction Factor = Antenna factor+ Insertion loss (cable loss + amplifier gain)

TA Technology (Shanghai) Co., Ltd. Test Report

Report No.: RXA1407-0191RF03

Page 61 of 93

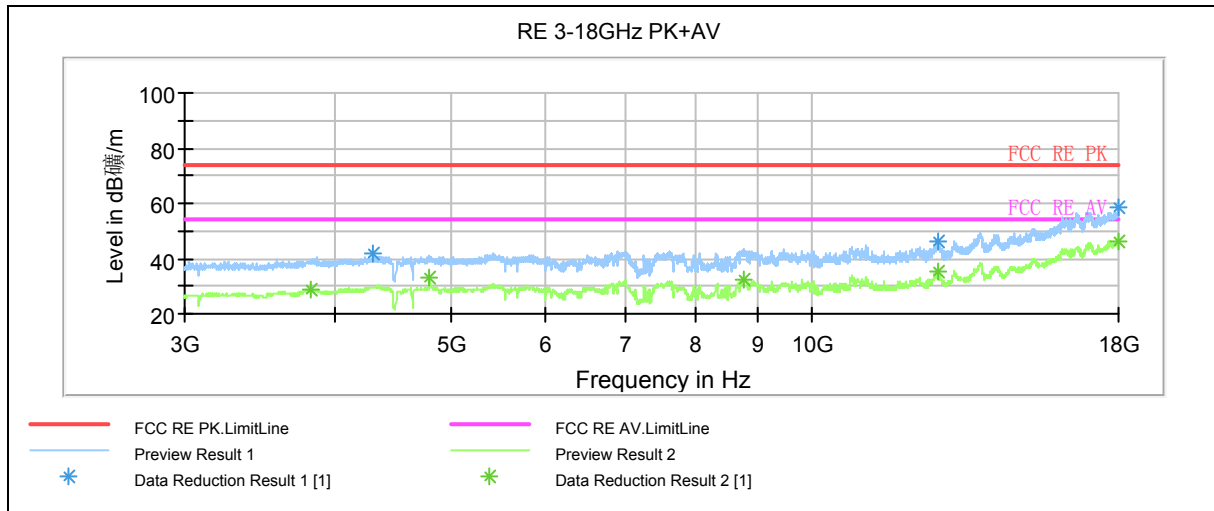

Radiates Emission from 3GHz to 18GHz

Note: This graph displays the maximum values of horizontal and vertical by software

Note: a font (Level in dB/m) in the test plot =(level in dBuV/m)

Frequency (MHz)	Peak (dBuV/m)	Height (cm)	Polarization	Azimuth (deg)	Reading value (dBuV/m)	Correct Factor (dB)	Margin (dB)	Limit (dBuV/m)
4314.375000	41.7	100.0	V	267.0	43.2	-1.5	32.3	74
12733.125000	46.2	100.0	H	293.0	58.8	-12.6	27.8	74
17998.125000	58.3	100.0	V	224.0	81.8	-23.5	15.7	74

Remark: 1. Correction Factor = Antenna factor+ Insertion loss (cable loss + amplifier gain)

Frequency (MHz)	Average (dBuV/m)	Height (cm)	Polarization	Azimuth (deg)	Reading value (dBuV/m)	Correct Factor (dB)	Margin (dB)	Limit (dBuV/m)
3826.875000	28.9	100.0	H	77.0	29.0	-0.1	25.1	54
4803.750000	33.2	100.0	V	60.0	34.8	-1.6	20.8	54
8778.750000	32.6	100.0	H	156.0	40.7	-8.1	21.4	54
12733.125000	35.4	100.0	H	293.0	48.0	-12.6	18.6	54
18000.000000	46.3	100.0	H	0.0	69.8	-23.5	7.7	54

Remark: 1. Correction Factor = Antenna factor+ Insertion loss (cable loss + amplifier gain)

TA Technology (Shanghai) Co., Ltd. Test Report

Report No.: RXA1407-0191RF03

Page 62 of 93

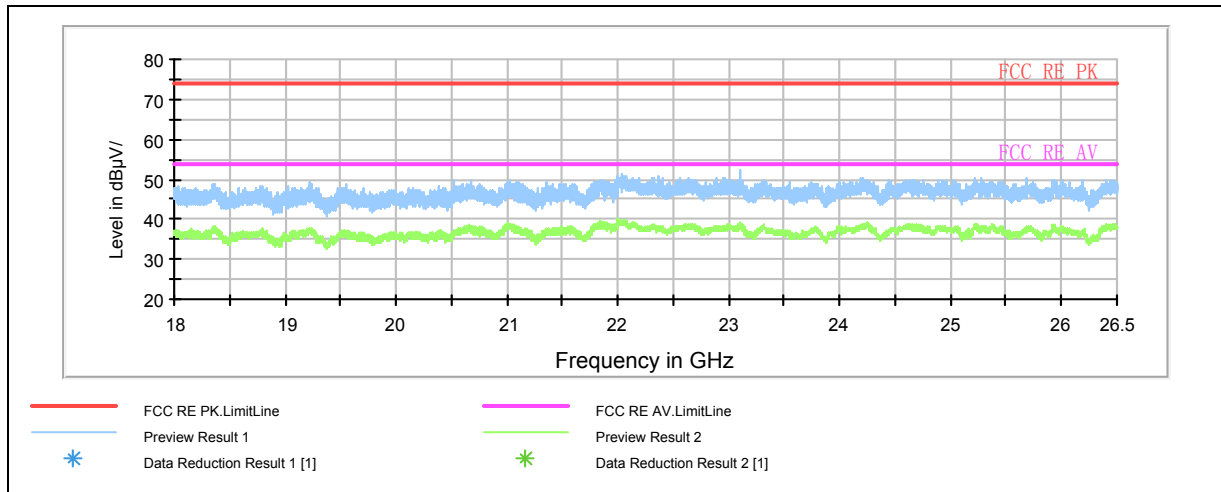

Radiates Emission from 18GHz to 26.5GHz

Note: This graph displays the maximum values of horizontal and vertical by software

Note: a font (Level in dBµV/m) in the test plot =(level in dBµV/m)

TA Technology (Shanghai) Co., Ltd. Test Report

Report No.: RXA1407-0191RF03

Page 63 of 93

DH5-Channel 39

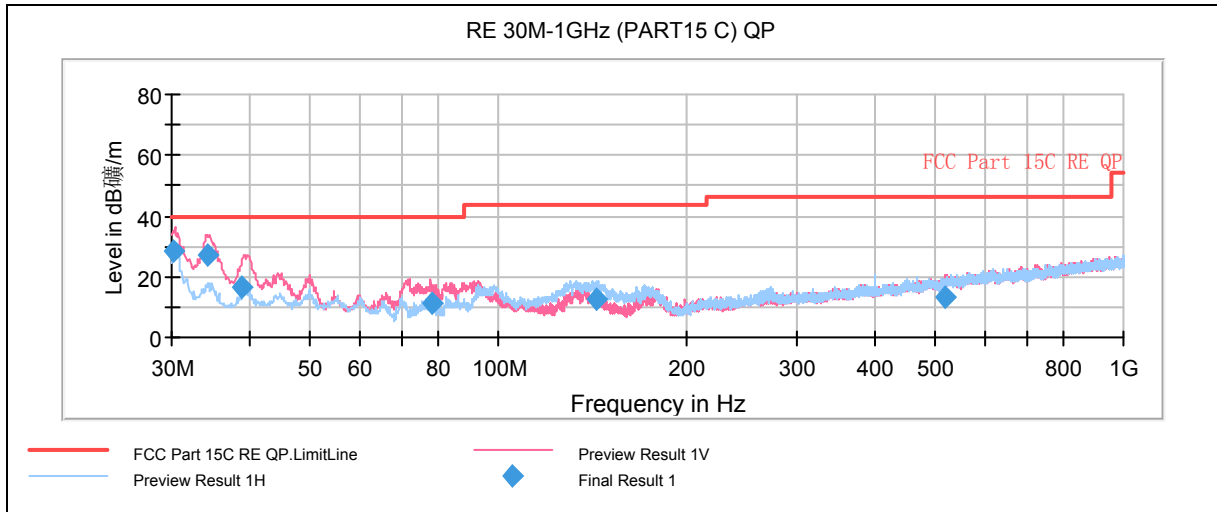

Radiates Emission from 30MHz to 1GHz

Note: This graph displays the maximum values of horizontal and vertical by software

Note: a font (Level in dB μ V/m) in the test plot =(level in dBuV/m)

Frequency (MHz)	Quasi-Peak (dBuV/m)	Height (cm)	Polarization	Azimuth (deg)	Reading value (dBuV/m)	Correct Factor (dB)	Margin (dB)	Limit (dBuV/m)
30.260000	28.7	101.0	V	0.0	45.9	-17.2	11.3	40.0
34.223750	27.0	100.0	V	151.0	45.9	-18.9	13.0	40.0
38.836250	16.2	102.0	V	6.0	35.5	-19.3	23.8	40.0
78.315000	11.4	126.0	V	26.0	39.6	-28.2	28.6	40.0
143.675000	12.8	225.0	H	119.0	42.0	-29.2	30.7	43.5
517.238750	13.1	308.0	V	88.0	31.2	-18.1	32.9	46.0

Remark: 1. Quasi-Peak = Reading value + Correction factor

2. Correction Factor = Antenna factor+ Insertion loss(cable loss+amplifier gain)

3. Margin = Limit – Quasi-Peak

TA Technology (Shanghai) Co., Ltd. Test Report

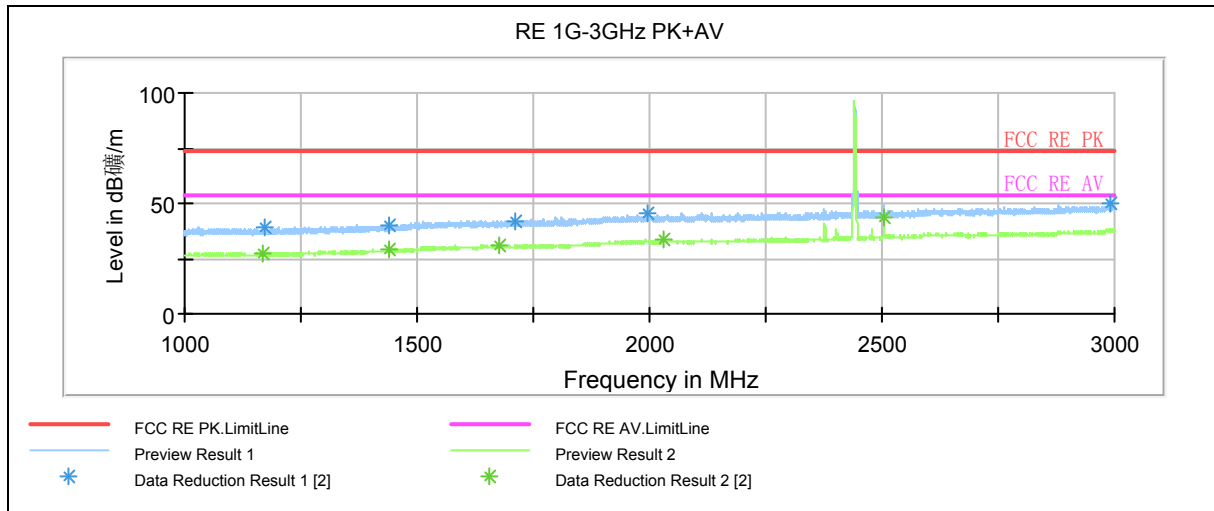

Radiates Emission from 1GHz to 3GHz

Note: The signal beyond the limit is carrier.

Note: This graph displays the maximum values of horizontal and vertical by software

Note: The signal beyond the limit is carrier. a font (Level in dB/m) in the test plot =(level in dBuV/m)

Frequency (MHz)	Peak (dBuV/m)	Height (cm)	Polarization	Azimuth (deg)	Reading value (dBuV/m)	Correct Factor (dB)	Margin (dB)	Limit (dBuV/m)
1173.750000	39.5	100.0	V	0.0	49.0	-9.5	34.5	74
1439.500000	39.9	100.0	H	15.0	47.9	-8.0	34.1	74
1712.750000	42.0	100.0	H	29.0	47.5	-5.5	32.0	74
1994.750000	45.4	100.0	H	0.0	48.3	-2.9	28.6	74
2990.500000	49.8	100.0	V	194.0	51.2	-1.4	24.2	74

Remark: 1. Correction Factor = Antenna factor+ Insertion loss (cable loss + amplifier gain)

Frequency (MHz)	Average (dBuV/m)	Height (cm)	Polarization	Azimuth (deg)	Reading value (dBuV/m)	Correct Factor (dB)	Margin (dB)	Limit (dBuV/m)
1169.250000	27.7	100.0	H	0.0	37.2	-9.5	26.3	54
1437.750000	29.0	100.0	H	88.0	37.0	-8.0	25.0	54
1676.250000	30.9	100.0	V	0.0	36.5	-5.6	23.1	54
2032.250000	33.4	100.0	H	51.0	36.5	-3.1	20.6	54
2505.250000	43.3	100.0	H	333.0	44.2	-0.9	10.7	54

Remark: 1. Correction Factor = Antenna factor+ Insertion loss (cable loss + amplifier gain)

TA Technology (Shanghai) Co., Ltd. Test Report

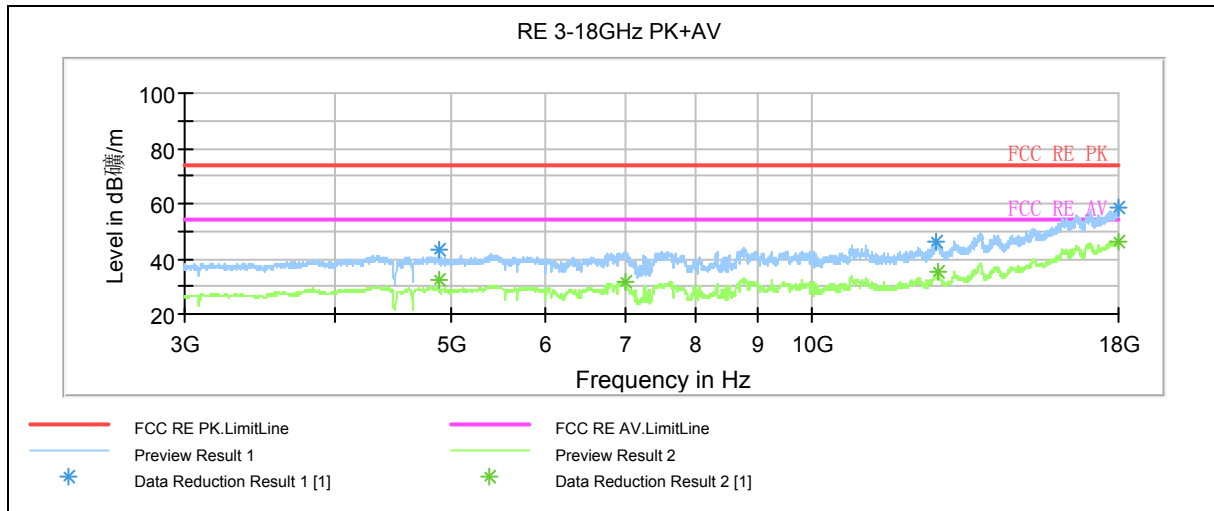

Radiates Emission from 3GHz to 18GHz

Note: This graph displays the maximum values of horizontal and vertical by software

Note: a font (Level in dB μ V/m)in the test plot =(level in dBuV/m)

Frequency (MHz)	Peak (dBuV/m)	Height (cm)	Polarization	Azimuth (deg)	Reading value (dBuV/m)	Correct Factor (dB)	Margin (dB)	Limit (dBuV/m)
4882.500000	43.0	100.0	V	0.0	44.8	-1.8	31.0	74
12680.625000	46.4	100.0	V	326.0	58.2	-11.8	27.6	74
17968.125000	58.4	100.0	H	71.0	81.8	-23.4	15.6	74

Remark: 1. Correction Factor = Antenna factor+ Insertion loss (cable loss + amplifier gain)

Frequency (MHz)	Average (dBuV/m)	Height (cm)	Polarization	Azimuth (deg)	Reading value (dBuV/m)	Correct Factor (dB)	Margin (dB)	Limit (dBuV/m)
4880.625000	32.3	100.0	V	0.0	34.2	-1.9	21.7	54
6997.500000	31.4	100.0	V	344.0	36.4	-5.0	22.6	54
12712.500000	35.2	100.0	V	335.0	47.6	-12.4	18.8	54
17998.125000	46.5	100.0	H	54.0	70.0	-23.5	7.5	54

Remark: 1. Correction Factor = Antenna factor+ Insertion loss (cable loss + amplifier gain)

TA Technology (Shanghai) Co., Ltd. Test Report

Report No.: RXA1407-0191RF03

Page 66 of 93

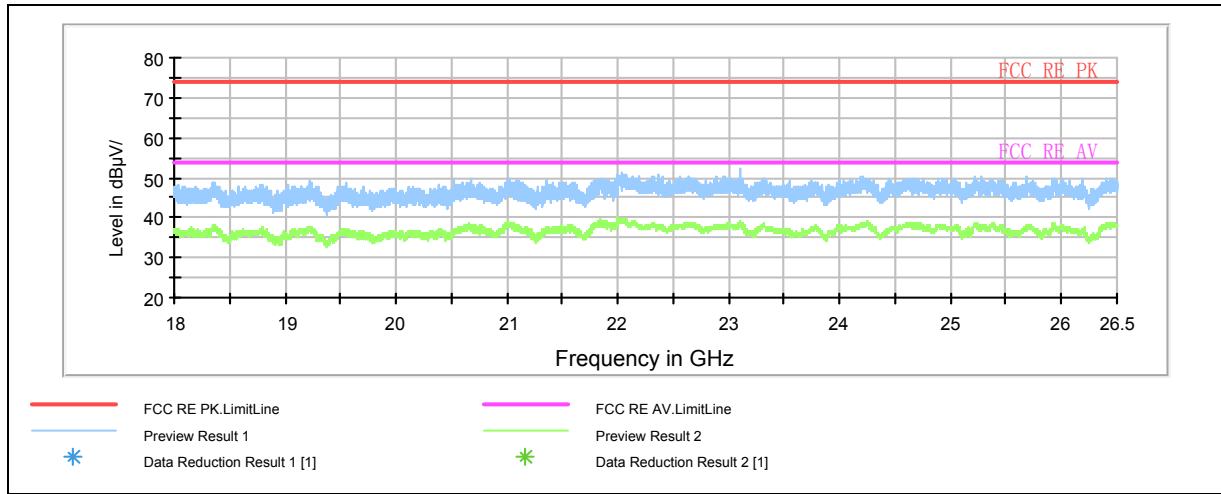

Radiates Emission from 18GHz to 26.5GHz

Note: This graph displays the maximum values of horizontal and vertical by software

Note: a font (Level in dBµV/m) in the test plot =(level in dBµV/m)

TA Technology (Shanghai) Co., Ltd. Test Report

DH5-Channel 78

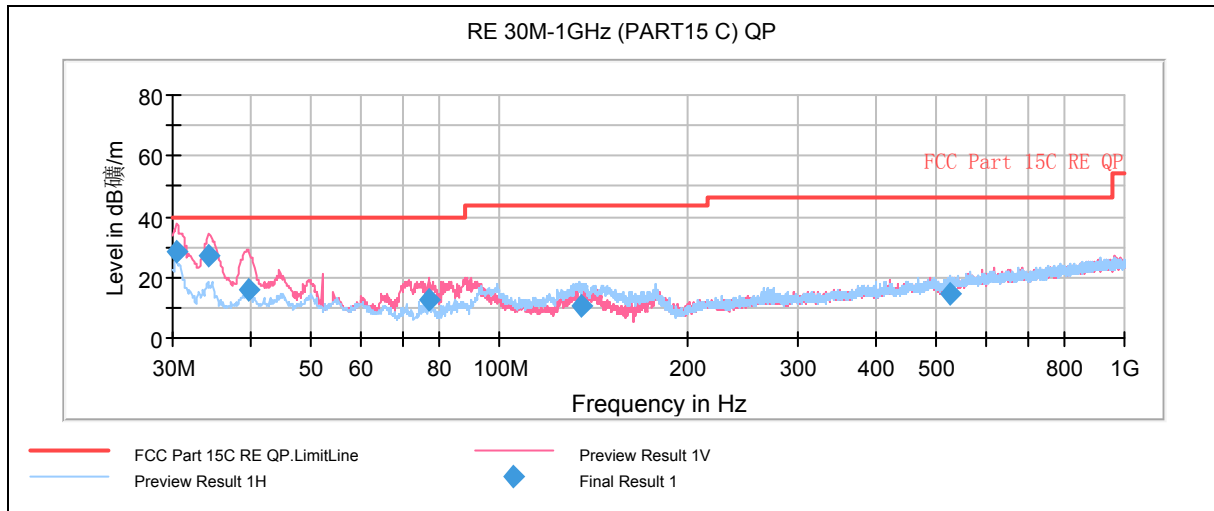

Radiates Emission from 30MHz to 1GHz

Note: This graph displays the maximum values of horizontal and vertical by software

Note: a font (Level in dB/m) in the test plot =(level in dBuV/m)

Frequency (MHz)	Quasi-Peak (dBuV/m)	Height (cm)	Polarization	Azimuth (deg)	Reading value (dBuV/m)	Correct Factor (dB)	Margin (dB)	Limit (dBuV/m)
30.420000	28.7	126.0	V	45.0	45.9	-17.2	11.3	40.0
34.383750	27.4	101.0	V	235.0	46.3	-18.9	12.6	40.0
39.797500	16.1	101.0	V	16.0	35.4	-19.3	23.9	40.0
77.146250	12.8	126.0	V	6.0	40.9	-28.1	27.2	40.0
134.856250	10.5	207.0	H	78.0	39.4	-28.9	33.0	43.5
527.106250	14.3	195.0	H	241.0	32.0	-17.7	31.7	46.0

Remark: 1. Quasi-Peak = Reading value + Correction factor

2. Correction Factor = Antenna factor+ Insertion loss(cable loss+amplifier gain)

3. Margin = Limit – Quasi-Peak

TA Technology (Shanghai) Co., Ltd. Test Report

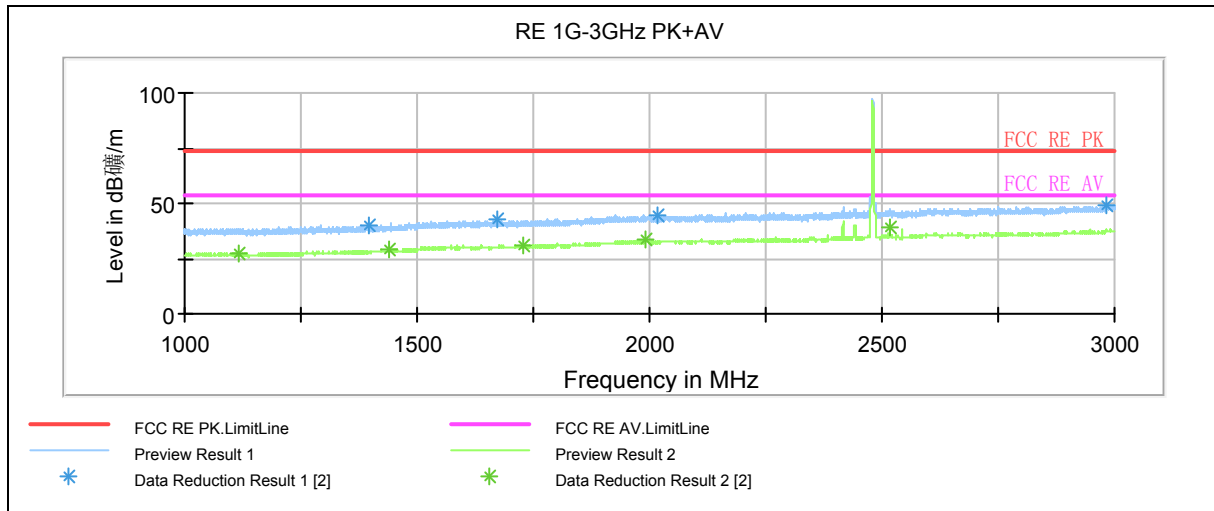

Radiates Emission from 1GHz to 3GHz

Note: The signal beyond the limit is carrier.

Note: This graph displays the maximum values of horizontal and vertical by software

Note: The signal beyond the limit is carrier. a font (Level in dB/m) in the test plot =(level in dBuV/m)

Frequency (MHz)	Peak (dBuV/m)	Height (cm)	Polarization	Azimuth (deg)	Reading value (dBuV/m)	Correct Factor (dB)	Margin (dB)	Limit (dBuV/m)
1397.000000	40.0	100.0	H	0.0	48.4	-8.4	34.0	74
1671.750000	42.7	100.0	H	117.0	48.3	-5.6	31.3	74
2018.750000	44.3	100.0	H	123.0	47.6	-3.3	29.7	74
2984.250000	49.3	100.0	H	0.0	50.6	-1.3	24.7	74

Remark: 1. Correction Factor = Antenna factor+ Insertion loss (cable loss + amplifier gain)

Frequency (MHz)	Average (dBuV/m)	Height (cm)	Polarization	Azimuth (deg)	Reading value (dBuV/m)	Correct Factor (dB)	Margin (dB)	Limit (dBuV/m)
1118.250000	27.3	100.0	V	334.0	37.0	-9.7	26.7	54
1441.750000	28.7	100.0	H	57.0	36.6	-7.9	25.3	54
1729.750000	30.9	100.0	V	298.0	36.6	-5.7	23.1	54
1990.250000	33.2	100.0	V	216.0	36.3	-3.1	20.8	54
2518.750000	38.9	100.0	H	332.0	39.8	-0.9	15.1	54

Remark: 1. Correction Factor = Antenna factor+ Insertion loss (cable loss + amplifier gain)

TA Technology (Shanghai) Co., Ltd. Test Report

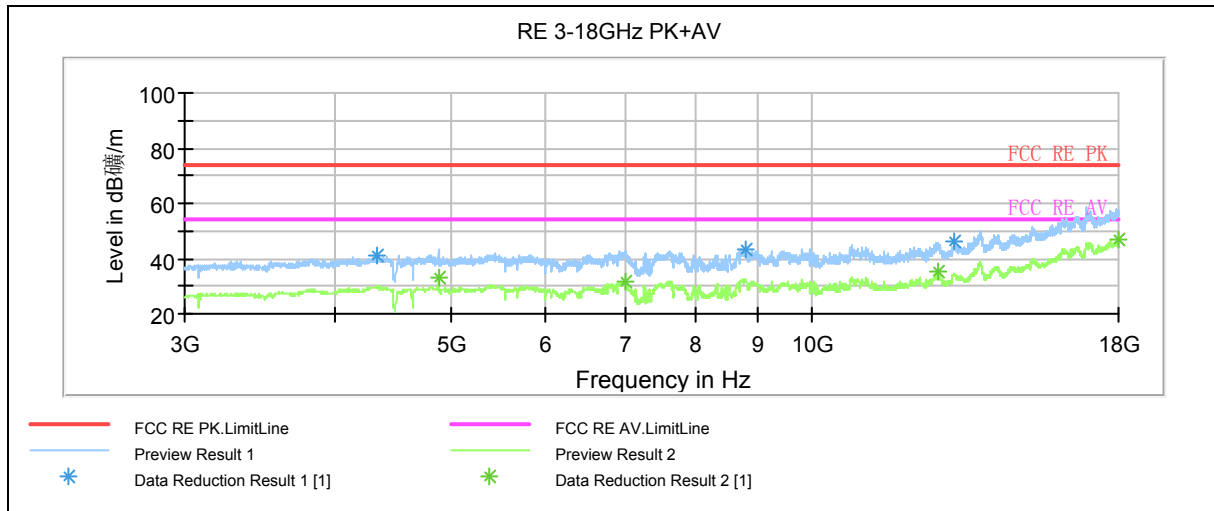

Radiates Emission from 3GHz to 18GHz

Note: This graph displays the maximum values of horizontal and vertical by software

Note: a font (Level in dB/m) in the test plot =(level in dBuV/m)

Frequency (MHz)	Peak (dBuV/m)	Height (cm)	Polarization	Azimuth (deg)	Reading value (dBuV/m)	Correct Factor (dB)	Margin (dB)	Limit (dBuV/m)
4344.375000	41.3	100.0	H	0.0	42.8	-1.5	32.7	74
8788.125000	43.3	100.0	H	76.0	51.4	-8.1	30.7	74
13123.125000	46.0	100.0	H	33.0	58.8	-12.8	28.0	74

Remark: 1. Correction Factor = Antenna factor+ Insertion loss (cable loss + amplifier gain)

Frequency (MHz)	Average (dBuV/m)	Height (cm)	Polarization	Azimuth (deg)	Reading value (dBuV/m)	Correct Factor (dB)	Margin (dB)	Limit (dBuV/m)
4880.625000	32.8	100.0	V	0.0	34.7	-1.9	21.2	54
6997.500000	31.8	100.0	V	176.0	36.8	-5.0	22.2	54
12718.125000	35.0	100.0	V	248.0	47.5	-12.5	19.0	54
17998.125000	46.5	100.0	V	105.0	70.0	-23.5	7.5	54

Remark: 1. Correction Factor = Antenna factor+ Insertion loss (cable loss + amplifier gain)

TA Technology (Shanghai) Co., Ltd. Test Report

Report No.: RXA1407-0191RF03

Page 70 of 93

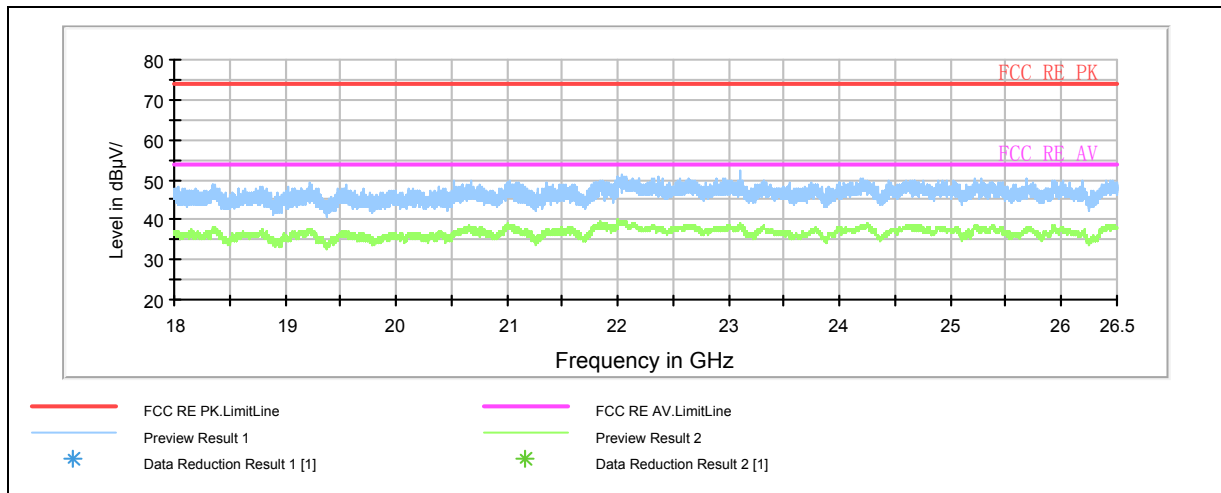

Radiates Emission from 18GHz to 26.5GHz

Note: This graph displays the maximum values of horizontal and vertical by software

Note: a font (Level in dBµV/m) in the test plot =(level in dBµV/m)

TA Technology (Shanghai) Co., Ltd. Test Report

Report No.: RXA1407-0191RF03

Page 71 of 93

3DH5-Channel 0

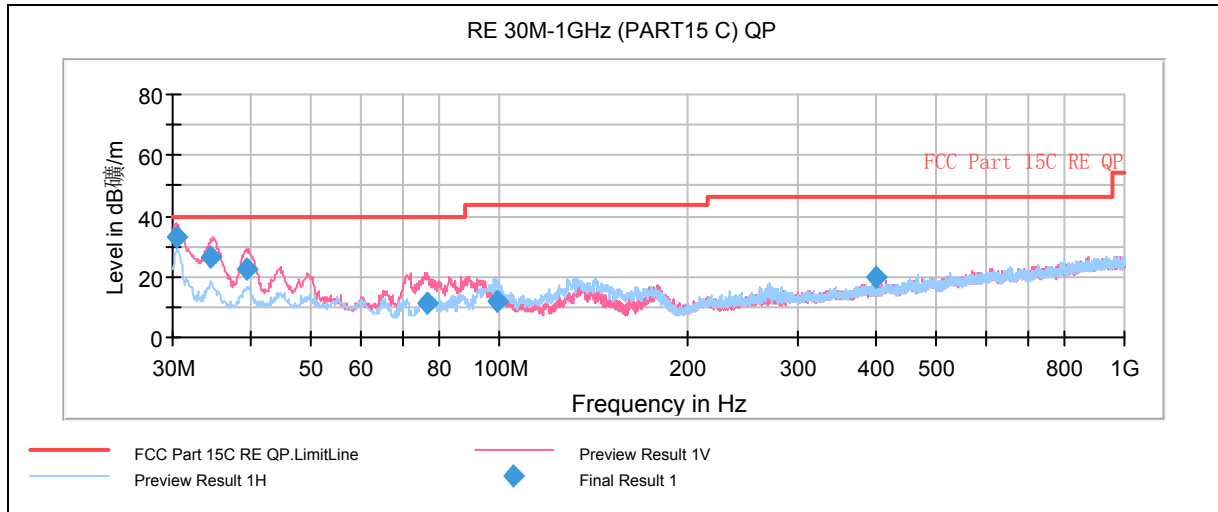

Note: This graph displays the maximum values of horizontal and vertical by software

Note: a font (Level in dBµV/m) in the test plot =(level in dBuV/m)

Radiates Emission from 30MHz to 1GHz

Frequency (MHz)	Quasi-Peak (dBuV/m)	Height (cm)	Polarization	Azimuth (deg)	Reading value (dBuV/m)	Correct Factor (dB)	Margin (dB)	Limit (dBuV/m)
30.260000	28.8	100.0	V	299.0	46.0	-17.2	11.2	40.0
34.506250	26.7	100.0	V	169.0	45.7	-19.0	13.3	40.0
39.596250	20.0	124.0	V	309.0	39.3	-19.3	20.0	40.0
71.158750	11.7	100.0	V	16.0	39.5	-27.8	28.3	40.0
134.332500	13.8	223.0	H	99.0	42.7	-28.9	29.7	43.5
525.120000	14.1	200.0	V	296.0	31.9	-17.8	31.9	46.0

Remark: 1. Quasi-Peak = Reading value + Correction factor

2. Correction Factor = Antenna factor+ Insertion loss(cable loss+amplifier gain)

3. Margin = Limit – Quasi-Peak

TA Technology (Shanghai) Co., Ltd. Test Report

Report No.: RXA1407-0191RF03

Page 72 of 93

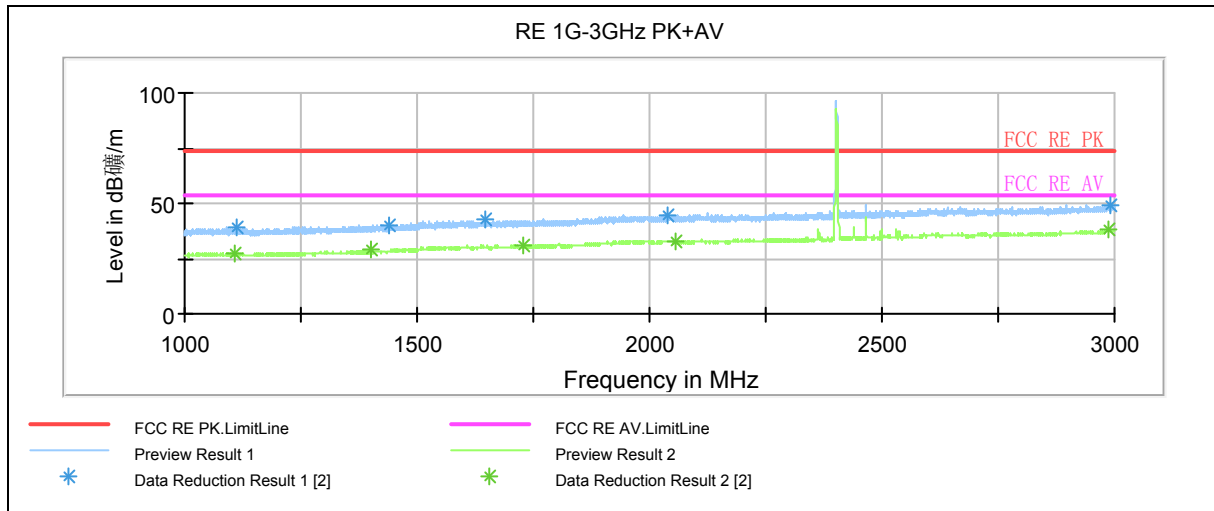

Radiates Emission from 1GHz to 3GHz

Note: The signal beyond the limit is carrier.

Note: This graph displays the maximum values of horizontal and vertical by software

Note: The signal beyond the limit is carrier. a font (Level in dB/m) in the test plot =(level in dBuV/m)

Frequency (MHz)	Peak (dBuV/m)	Height (cm)	Polarization	Azimuth (deg)	Reading value (dBuV/m)	Correct Factor (dB)	Margin (dB)	Limit (dBuV/m)
1110.000000	39.2	100.0	H	106.0	49.0	-9.8	34.8	74
1441.500000	40.2	100.0	H	0.0	48.1	-7.9	33.8	74
1645.000000	42.5	100.0	V	173.0	47.8	-5.3	31.5	74
2038.500000	44.3	100.0	V	220.0	47.3	-3.0	29.7	74
2991.000000	49.3	100.0	H	40.0	50.7	-1.4	24.7	74

Remark: 1. Correction Factor = Antenna factor+ Insertion loss (cable loss + amplifier gain)

Frequency (MHz)	Average (dBuV/m)	Height (cm)	Polarization	Azimuth (deg)	Reading value (dBuV/m)	Correct Factor (dB)	Margin (dB)	Limit (dBuV/m)
1109.250000	27.6	100.0	V	0.0	37.4	-9.8	26.4	54
1401.750000	28.7	100.0	V	0.0	37.1	-8.4	25.3	54
1730.250000	30.8	100.0	V	341.0	36.4	-5.6	23.2	54
2057.250000	33.2	100.0	H	130.0	36.2	-3.0	20.8	54
2985.000000	38.0	100.0	H	256.0	39.3	-1.3	16.0	54

Remark: 1. Correction Factor = Antenna factor+ Insertion loss (cable loss + amplifier gain)

TA Technology (Shanghai) Co., Ltd. Test Report

Report No.: RXA1407-0191RF03

Page 73 of 93

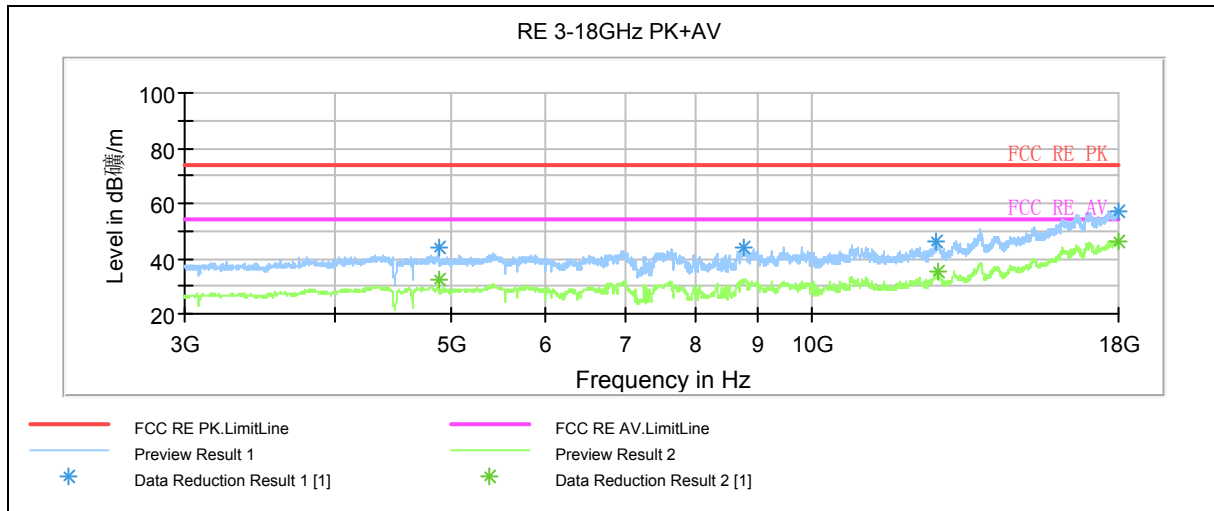

Radiates Emission from 3GHz to 18GHz

Note: This graph displays the maximum values of horizontal and vertical by software

Note: a font (Level in dB/m) in the test plot =(level in dBuV/m)

Frequency (MHz)	Peak (dBuV/m)	Height (cm)	Polarization	Azimuth (deg)	Reading value (dBuV/m)	Correct Factor (dB)	Margin (dB)	Limit (dBuV/m)
4880.625000	44.0	100.0	V	0.0	45.9	-1.9	30.0	74
8784.375000	43.8	100.0	H	33.0	51.9	-8.1	30.2	74
12697.500000	46.0	100.0	H	193.0	58.1	-12.1	28.0	74
17977.500000	57.0	100.0	H	86.0	80.4	-23.4	17.0	74

Remark: 1. Correction Factor = Antenna factor+ Insertion loss (cable loss + amplifier gain)

Frequency (MHz)	Average (dBuV/m)	Height (cm)	Polarization	Azimuth (deg)	Reading value (dBuV/m)	Correct Factor (dB)	Margin (dB)	Limit (dBuV/m)
4880.625000	32.6	100.0	V	0.0	34.5	-1.9	21.4	54
12733.125000	35.2	100.0	V	324.0	47.8	-12.6	18.8	54
17977.500000	46.4	100.0	V	194.0	69.8	-23.4	7.6	54

Remark: 1. Correction Factor = Antenna factor+ Insertion loss (cable loss + amplifier gain)

TA Technology (Shanghai) Co., Ltd. Test Report

Report No.: RXA1407-0191RF03

Page 74 of 93

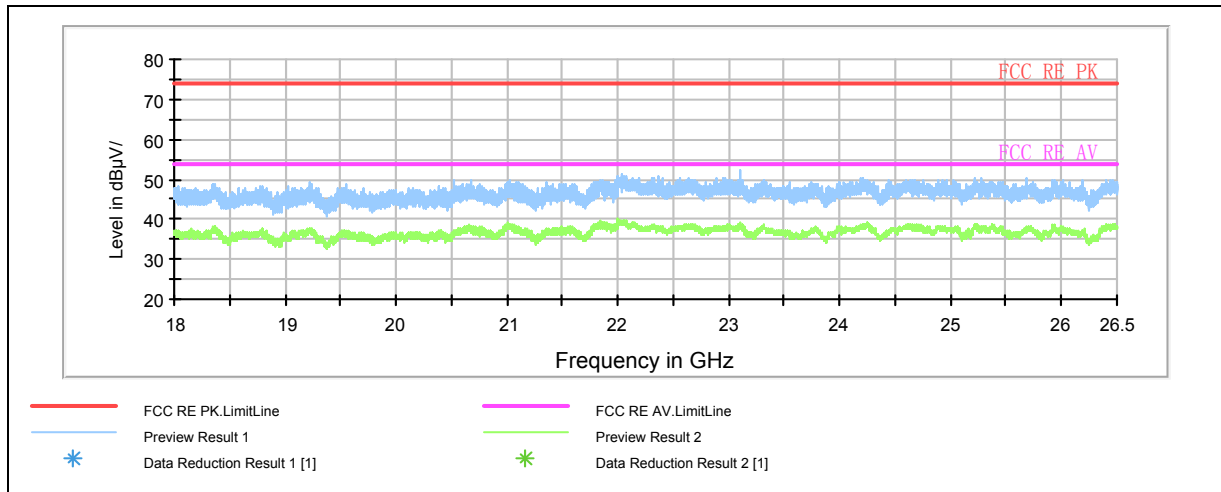

Radiates Emission from 18GHz to 26.5GHz

Note: This graph displays the maximum values of horizontal and vertical by software

Note: a font (Level in dBµV/m) in the test plot =(level in dBµV/m)

TA Technology (Shanghai) Co., Ltd. Test Report

Report No.: RXA1407-0191RF03

Page 75 of 93

3DH5-Channel 39

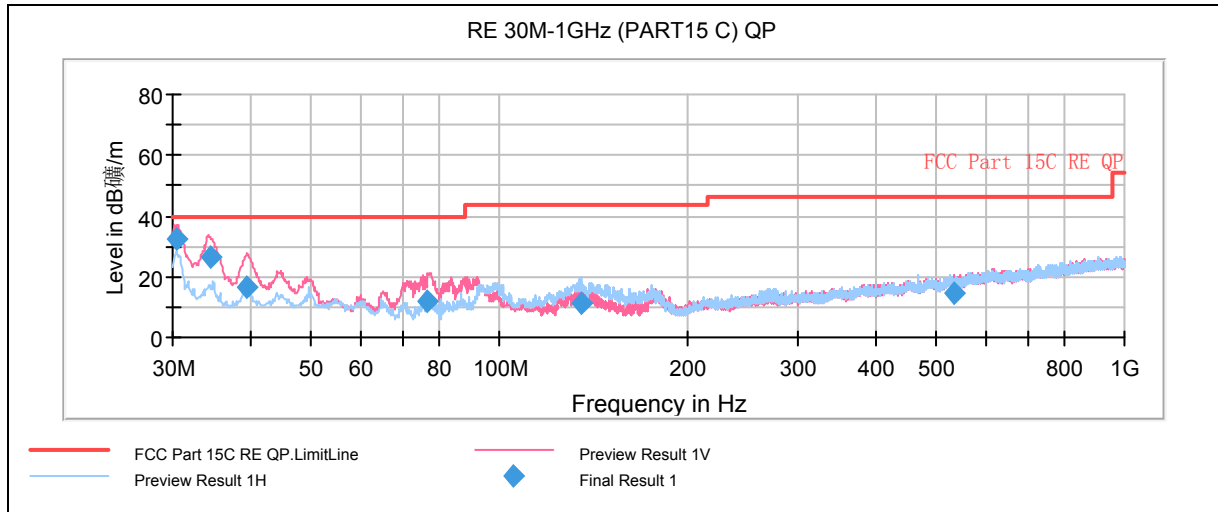

Radiates Emission from 30MHz to 1GHz

Note: This graph displays the maximum values of horizontal and vertical by software

Note: a font (Level in dB μ V/m) in the test plot =(level in dBuV/m)

Frequency (MHz)	Quasi-Peak (dBuV/m)	Height (cm)	Polarization	Azimuth (deg)	Reading value (dBuV/m)	Correct Factor (dB)	Margin (dB)	Limit (dBuV/m)
30.260000	28.7	101.0	V	0.0	45.9	-17.2	11.3	40.0
34.223750	27.0	100.0	V	151.0	45.9	-18.9	13.0	40.0
38.836250	16.2	102.0	V	6.0	35.5	-19.3	23.8	40.0
78.315000	11.4	126.0	V	26.0	39.6	-28.2	28.6	40.0
143.675000	12.8	225.0	H	119.0	42.0	-29.2	30.7	43.5
517.238750	13.1	308.0	V	88.0	31.2	-18.1	32.9	46.0

Remark: 1. Quasi-Peak = Reading value + Correction factor

2. Correction Factor = Antenna factor+ Insertion loss(cable loss+amplifier gain)

3. Margin = Limit – Quasi-Peak

TA Technology (Shanghai) Co., Ltd. Test Report

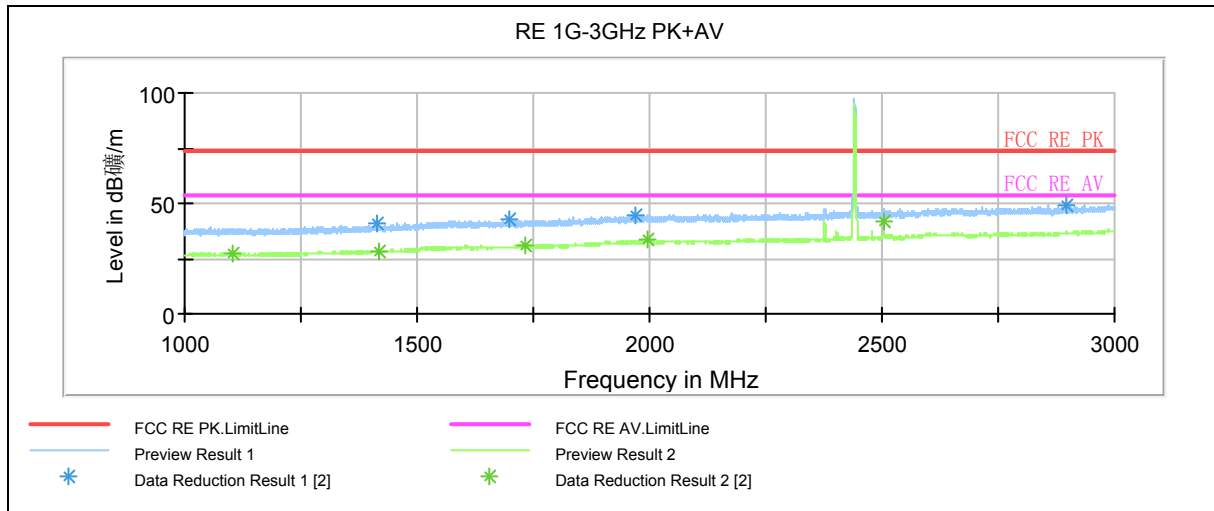

Radiates Emission from 1GHz to 3GHz

Note: The signal beyond the limit is carrier.

Note: This graph displays the maximum values of horizontal and vertical by software

Note: The signal beyond the limit is carrier. a font (Level in dB/m) in the test plot =(level in dBuV/m)

Frequency (MHz)	Peak (dBuV/m)	Height (cm)	Polarization	Azimuth (deg)	Reading value (dBuV/m)	Correct Factor (dB)	Margin (dB)	Limit (dBuV/m)
1415.500000	41.1	100.0	V	241.0	49.3	-8.2	32.9	74
1697.000000	42.6	100.0	H	0.0	48.2	-5.6	31.4	74
1970.000000	44.5	100.0	H	88.0	48.0	-3.5	29.5	74
2898.250000	48.8	100.0	H	307.0	49.6	-0.8	25.2	74

Remark: 1. Correction Factor = Antenna factor+ Insertion loss (cable loss + amplifier gain)

Frequency (MHz)	Average (dBuV/m)	Height (cm)	Polarization	Azimuth (deg)	Reading value (dBuV/m)	Correct Factor (dB)	Margin (dB)	Limit (dBuV/m)
1104.250000	27.6	100.0	H	95.0	37.5	-9.9	26.4	54
1419.750000	28.6	100.0	H	63.0	36.7	-8.1	25.4	54
1731.750000	30.6	100.0	H	233.0	36.1	-5.5	23.4	54
1993.750000	33.3	100.0	H	147.0	36.2	-2.9	20.7	54
2505.500000	41.5	100.0	H	0.0	42.4	-0.9	12.5	54

Remark: 1. Correction Factor = Antenna factor+ Insertion loss (cable loss + amplifier gain)

TA Technology (Shanghai) Co., Ltd. Test Report

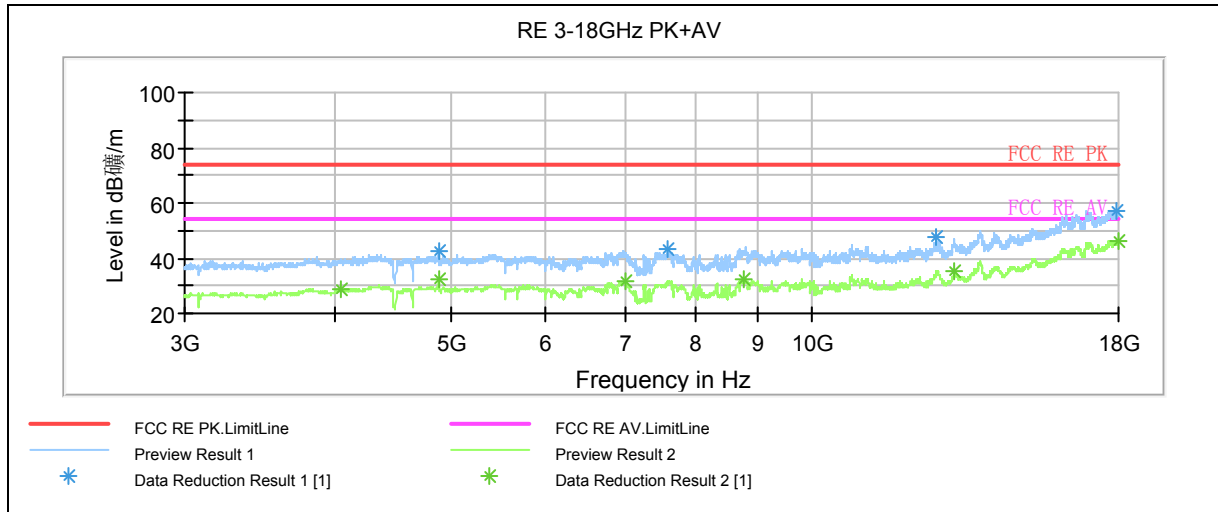

Radiates Emission from 3GHz to 18GHz

Note: This graph displays the maximum values of horizontal and vertical by software

Note: a font (Level in dB/m) in the test plot =(level in dBuV/m)

Frequency (MHz)	Peak (dBuV/m)	Height (cm)	Polarization	Azimuth (deg)	Reading value (dBuV/m)	Correct Factor (dB)	Margin (dB)	Limit (dBuV/m)
12693.750000	47.4	100.0	V	350.0	59.4	-12.0	26.6	74
17926.875000	57.2	100.0	V	218.0	80.6	-23.4	16.8	74
4880.625000	42.6	100.0	V	7.0	44.5	-1.9	31.4	74
7591.875000	43.2	100.0	H	138.0	49.9	-6.7	30.8	74

Remark: 1. Correction Factor = Antenna factor+ Insertion loss (cable loss + amplifier gain)

Frequency (MHz)	Average (dBuV/m)	Height (cm)	Polarization	Azimuth (deg)	Reading value (dBuV/m)	Correct Factor (dB)	Margin (dB)	Limit (dBuV/m)
4042.500000	28.7	100.0	H	0.0	29.0	-0.3	25.3	54
4880.625000	32.6	100.0	V	7.0	34.5	-1.9	21.4	54
6991.875000	31.5	100.0	V	341.0	36.5	-5.0	22.5	54
8780.625000	32.4	100.0	H	0.0	40.5	-8.1	21.6	54
13128.750000	35.3	100.0	H	129.0	48.1	-12.8	18.7	54
17992.500000	46.4	100.0	V	0.0	69.9	-23.5	7.6	54

Remark: 1. Correction Factor = Antenna factor+ Insertion loss (cable loss + amplifier gain)

TA Technology (Shanghai) Co., Ltd. Test Report

Report No.: RXA1407-0191RF03

Page 78 of 93

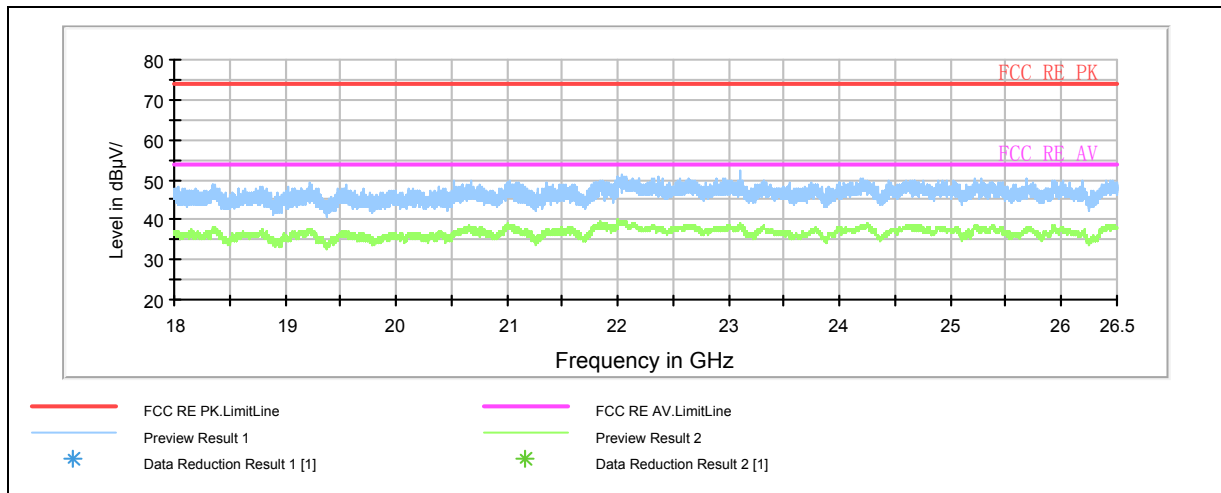

Radiates Emission from 18GHz to 26.5GHz

Note: This graph displays the maximum values of horizontal and vertical by software

Note: a font (Level in dBµV/m) in the test plot =(level in dBµV/m)

TA Technology (Shanghai) Co., Ltd. Test Report

3DH5-Channel 78

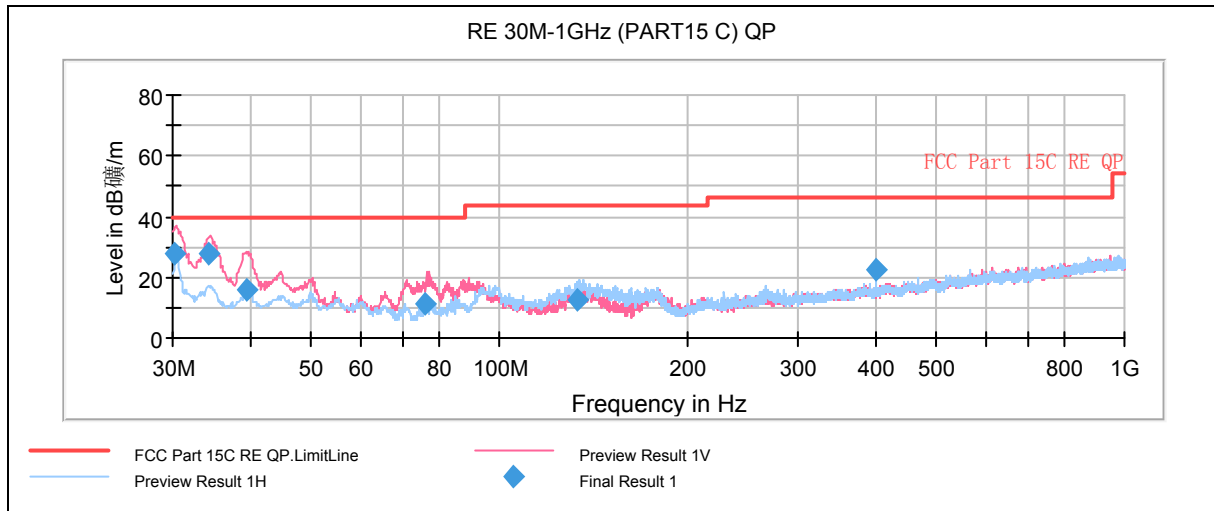

Radiates Emission from 30MHz to 1GHz

Note: This graph displays the maximum values of horizontal and vertical by software

Note: a font (Level in dB/m) in the test plot =(level in dBuV/m)

Frequency (MHz)	Quasi-Peak (dBuV/m)	Height (cm)	Polarization	Azimuth (deg)	Reading value (dBuV/m)	Correct Factor (dB)	Margin (dB)	Limit (dBuV/m)
30.300000	28.0	100.0	V	237.0	45.2	-17.2	12.0	40.0
34.347500	27.6	100.0	V	138.0	46.5	-18.9	12.4	40.0
39.518750	16.1	120.0	V	0.0	35.4	-19.3	23.9	40.0
76.258750	11.2	125.0	V	0.0	39.3	-28.1	28.8	40.0
133.652500	12.3	176.0	H	91.0	41.2	-28.9	31.2	43.5
399.995000	22.2	100.0	H	349.0	42.4	-20.2	23.8	46.0

Remark: 1. Quasi-Peak = Reading value + Correction factor

2. Correction Factor = Antenna factor+ Insertion loss(cable loss+amplifier gain)

3. Margin = Limit – Quasi-Peak

TA Technology (Shanghai) Co., Ltd. Test Report

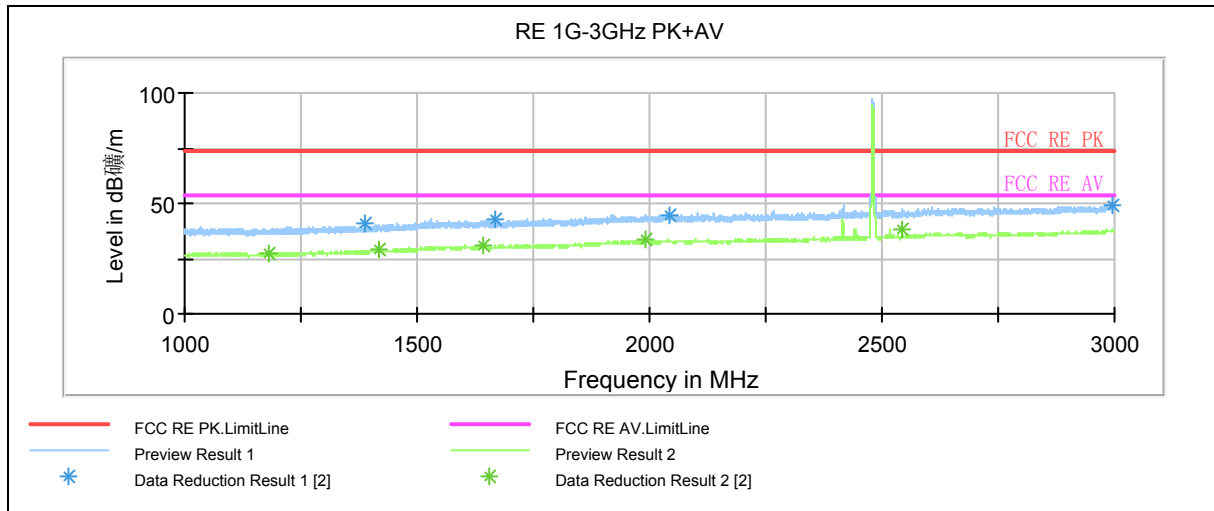

Radiates Emission from 1GHz to 3GHz

Note: The signal beyond the limit is carrier.

Note: This graph displays the maximum values of horizontal and vertical by software

Note: The signal beyond the limit is carrier. a font (Level in dB/m) in the test plot =(level in dBuV/m)

Frequency (MHz)	Peak (dBuV/m)	Height (cm)	Polarization	Azimuth (deg)	Reading value (dBuV/m)	Correct Factor (dB)	Margin (dB)	Limit (dBuV/m)
1389.250000	40.7	100.0	H	185.0	49.0	-8.3	33.3	74
1668.750000	42.4	100.0	V	335.0	48.1	-5.7	31.6	74
2042.500000	45.0	100.0	H	89.0	48.0	-3.0	29.0	74
2997.250000	49.2	100.0	H	0.0	50.6	-1.4	24.8	74

Remark: 1. Correction Factor = Antenna factor+ Insertion loss (cable loss + amplifier gain)

Frequency (MHz)	Average (dBuV/m)	Height (cm)	Polarization	Azimuth (deg)	Reading value (dBuV/m)	Correct Factor (dB)	Margin (dB)	Limit (dBuV/m)
1181.750000	27.5	100.0	V	0.0	36.9	-9.4	26.5	54
1416.250000	28.7	100.0	V	343.0	36.9	-8.2	25.3	54
1643.250000	30.9	100.0	V	45.0	36.1	-5.2	23.1	54
1992.250000	33.2	100.0	V	159.0	36.2	-3.0	20.8	54
2544.000000	38.0	100.0	H	332.0	39.1	-1.1	16.0	54

Remark: 1. Correction Factor = Antenna factor+ Insertion loss (cable loss + amplifier gain)

TA Technology (Shanghai) Co., Ltd. Test Report

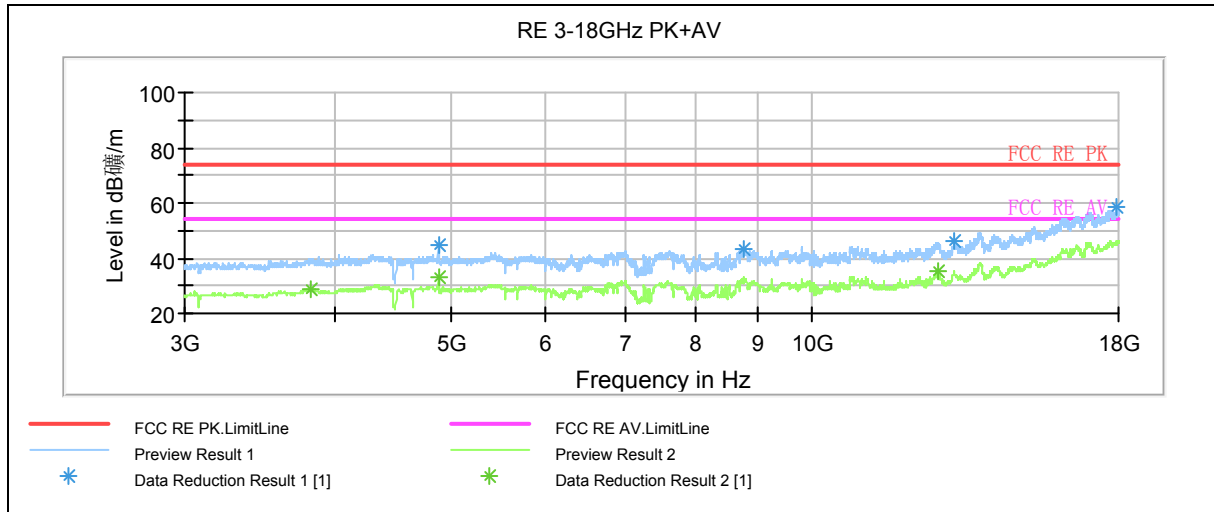

Radiates Emission from 3GHz to 18GHz

Note: This graph displays the maximum values of horizontal and vertical by software

Note: a font (Level in dB/m) in the test plot =(level in dBuV/m)

Frequency (MHz)	Peak (dBuV/m)	Height (cm)	Polarization	Azimuth (deg)	Reading value (dBuV/m)	Correct Factor (dB)	Margin (dB)	Limit (dBuV/m)
4880.625000	44.4	100.0	V	0.0	46.3	-1.9	29.6	74
8778.750000	43.5	100.0	H	75.0	51.6	-8.1	30.5	74
13115.625000	46.1	100.0	H	84.0	59.0	-12.9	27.9	74
17964.375000	58.3	100.0	H	0.0	81.7	-23.4	15.7	74

Remark: 1. Correction Factor = Antenna factor+ Insertion loss (cable loss + amplifier gain)

Frequency (MHz)	Average (dBuV/m)	Height (cm)	Polarization	Azimuth (deg)	Reading value (dBuV/m)	Correct Factor (dB)	Margin (dB)	Limit (dBuV/m)
3819.375000	29.0	100.0	H	48.0	29.2	-0.2	25.0	54
4880.625000	33.2	100.0	V	0.0	35.1	-1.9	20.8	54
12716.250000	35.2	100.0	V	29.0	47.7	-12.5	18.8	54

Remark: 1. Correction Factor = Antenna factor+ Insertion loss (cable loss + amplifier gain)

TA Technology (Shanghai) Co., Ltd. Test Report

Report No.: RXA1407-0191RF03

Page 82 of 93

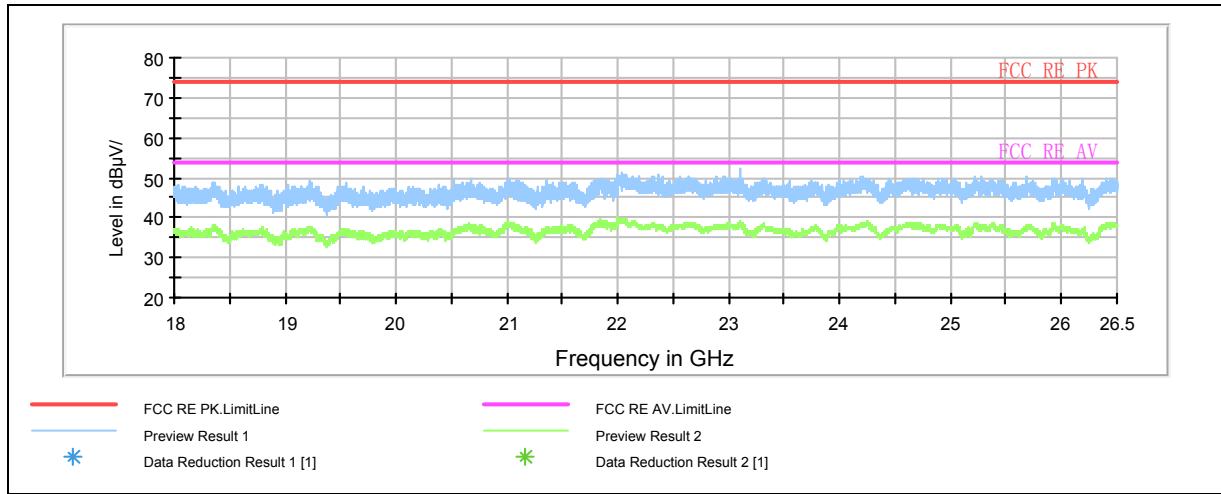

Radiates Emission from 18GHz to 26.5GHz

Note: This graph displays the maximum values of horizontal and vertical by software

Note: a font (Level in dBµV/m) in the test plot =(level in dBµV/m)

TA Technology (Shanghai) Co., Ltd.

Test Report

Report No.: RXA1407-0191RF03

Page 83of 93

3.12. Conducted Emission

Ambient condition

Temperature	Relative humidity	Pressure
23°C ~25°C	45%~50%	101.5kPa

Methods of Measurement

The EUT is placed on a non-metallic table of 80cm height above the horizontal metal reference ground plane. During the test, the EUT was operating in its typical mode. The test method is according to ANSI C63.4-2009. Connect the AC power line of the EUT to the L.I.S.N. Use EMI receiver to detect the average and Quasi-peak value. RBW is set to 9 kHz, VBW is set to 30kHz. The measurement result should include both L line and N line.

The test is in transmitting mode.

Test Setup

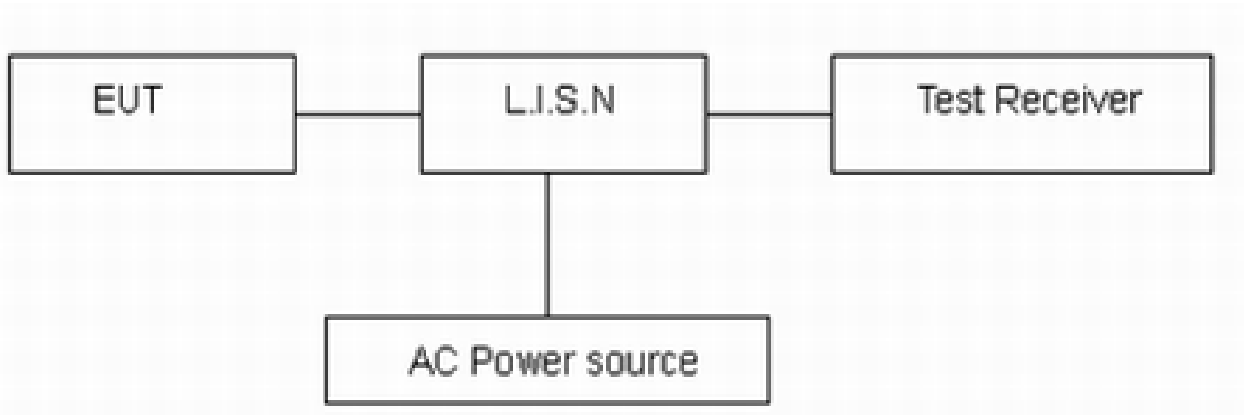

Note: AC Power source is used to change the voltage from 220V/50Hz to 110V/60Hz.

Limits

Frequency (MHz)	Conducted Limits(dB μ V)	
	Quasi-peak	Average
0.15 - 0.5	66 to 56 *	56 to 46 *
0.5 - 5	56	46
5 - 30	60	50

*: Decreases with the logarithm of the frequency.

Measurement Uncertainty

The assessed measurement uncertainty to ensure 95% confidence level for the normal distribution is with the coverage factor $k = 1.96$, $U = 2.69$ dB.

TA Technology (Shanghai) Co., Ltd. Test Report

Report No.: RXA1407-0191RF03

Page 84 of 93

Test Results:

DH5-CH39

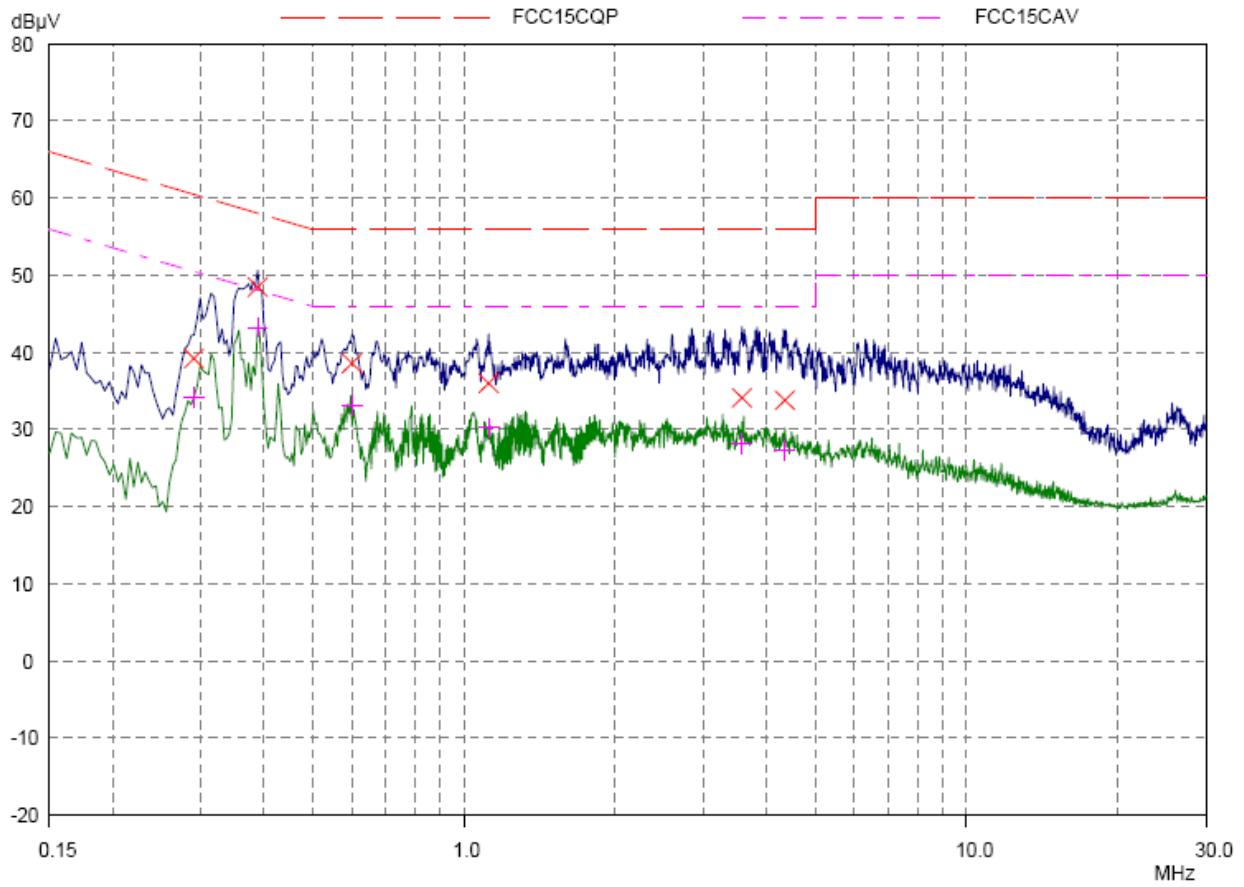

Final Measurement Results

Frequency MHz	QP Level dBμV	QP Limit dBμV	QP Delta dB	Phase -	PE -
0.29062	39.21	60.51	21.30	L1	gnd
0.38828	48.47	58.10	9.63	L1	gnd
0.59921	38.59	56.00	17.41	L1	gnd
1.11875	35.98	56.00	20.02	L1	gnd
3.57968	34.13	56.00	21.87	L1	gnd
4.34921	33.82	56.00	22.18	L1	gnd

Frequency MHz	AV Level dBμV	AV Limit dBμV	AV Delta dB	Phase -	PE -
0.29062	34.19	50.51	16.32	L1	gnd
0.38828	43.24	48.10	4.86	L1	gnd
0.59921	33.14	46.00	12.86	L1	gnd
1.11875	30.24	46.00	15.76	L1	gnd
3.57968	28.19	46.00	17.81	L1	gnd
4.34921	27.33	46.00	18.67	L1	gnd

L Line

TA Technology (Shanghai) Co., Ltd. Test Report

Report No.: RXA1407-0191RF03

Page 85 of 93

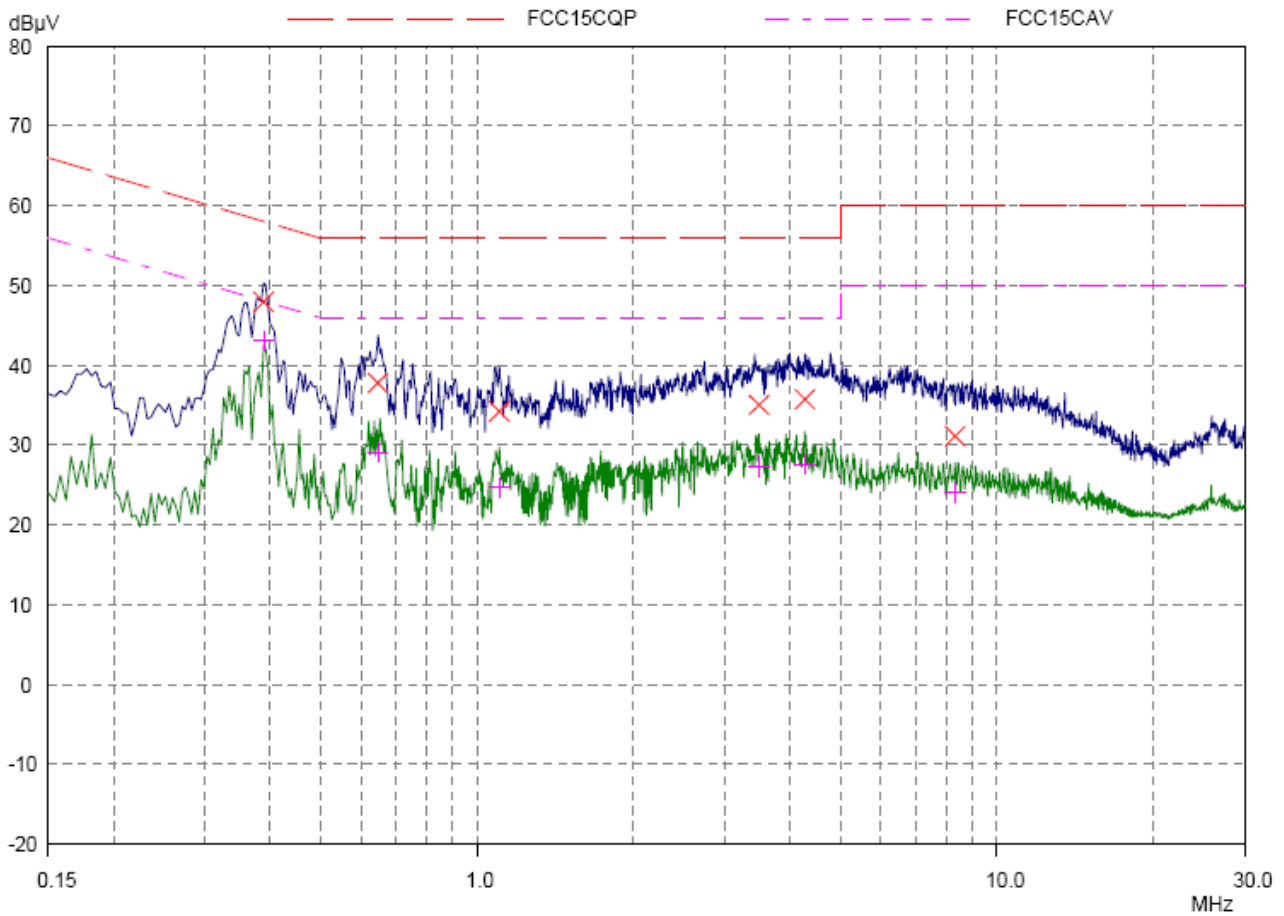

Final Measurement Results

Frequency MHz	QP Level dBµV	QP Limit dBµV	QP Delta dB	Phase -	PE -
0.38828	47.95	58.10	10.15	N	gnd
0.64609	37.82	56.00	18.18	N	gnd
1.10312	34.24	56.00	21.76	N	gnd
3.48984	35.05	56.00	20.95	N	gnd
4.26718	35.78	56.00	20.22	N	gnd
8.29453	31.16	60.00	28.84	N	gnd

Frequency MHz	AV Level dBµV	AV Limit dBµV	AV Delta dB	Phase -	PE -
0.38828	43.07	48.10	5.03	N	gnd
0.64609	29.13	46.00	16.87	N	gnd
1.10312	24.73	46.00	21.27	N	gnd
3.48984	27.32	46.00	18.68	N	gnd
4.26718	27.58	46.00	18.42	N	gnd
8.29453	24.05	50.00	25.95	N	gnd

N Line

Conducted Emission from 150 KHz to 30 MHz

TA Technology (Shanghai) Co., Ltd. Test Report

Report No.: RXA1407-0191RF03

Page 86 of 93

3DH5-CH39

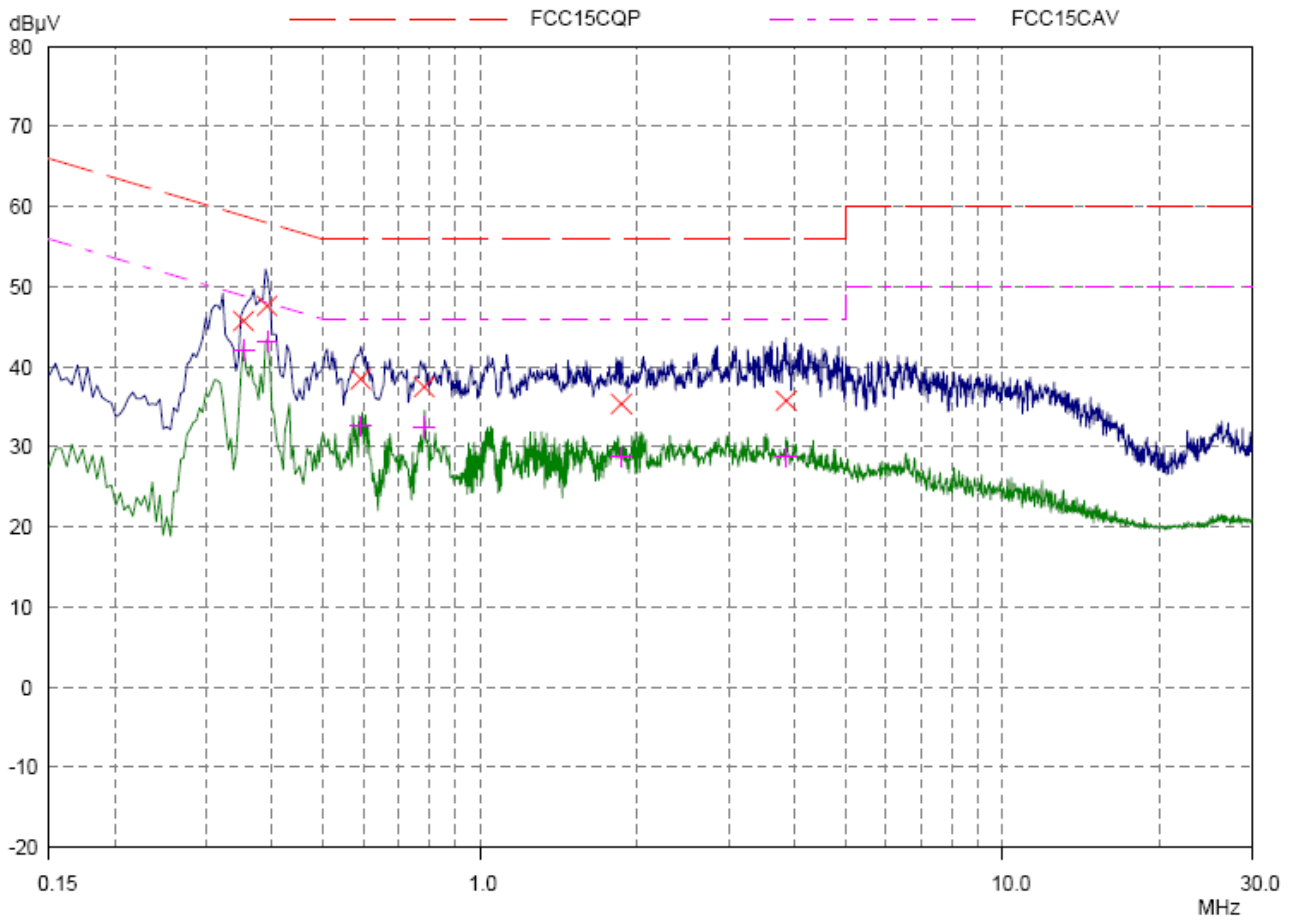

Final Measurement Results

Frequency MHz	QP Level dBµV	QP Limit dBµV	QP Delta dB	Phase -	PE -
0.35312	45.73	58.89	13.16	L1	gnd
0.39218	47.60	58.02	10.42	L1	gnd
0.5914	38.47	56.00	17.53	L1	gnd
0.78281	37.48	56.00	18.52	L1	gnd
1.86484	35.40	56.00	20.60	L1	gnd
3.85703	35.79	56.00	20.21	L1	gnd

Frequency MHz	AV Level dBµV	AV Limit dBµV	AV Delta dB	Phase -	PE -
0.35312	42.08	48.89	6.81	L1	gnd
0.39218	43.16	48.02	4.86	L1	gnd
0.5914	32.59	46.00	13.41	L1	gnd
0.78281	32.50	46.00	13.50	L1	gnd
1.86484	28.73	46.00	17.27	L1	gnd
3.85703	28.72	46.00	17.28	L1	gnd

L Line

TA Technology (Shanghai) Co., Ltd. Test Report

Report No.: RXA1407-0191RF03

Page 87 of 93

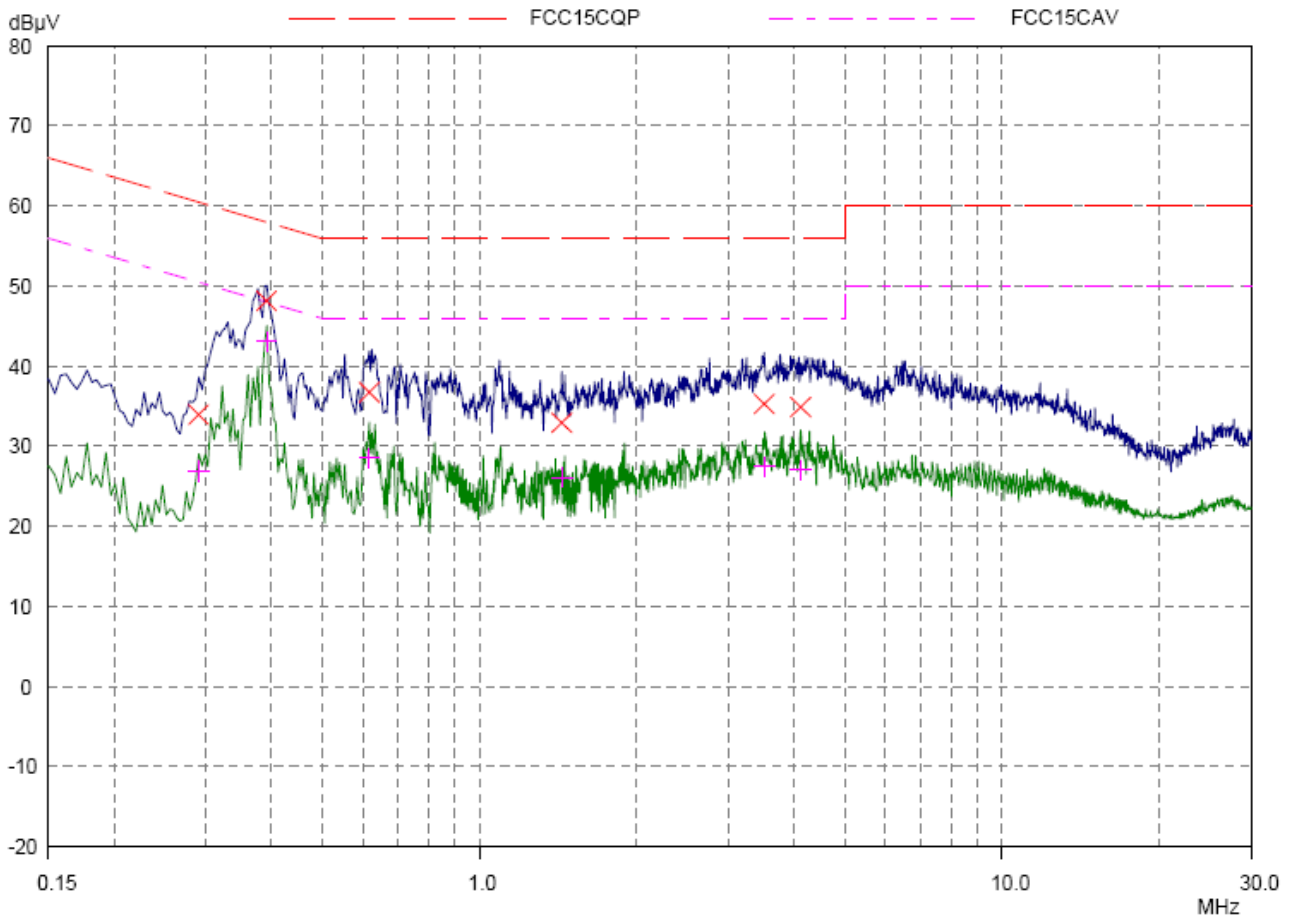

Final Measurement Results

Frequency MHz	QP Level dBµV	QP Limit dBµV	QP Delta dB	Phase -	PE -
0.29062	33.95	60.51	26.56	N	gnd
0.39218	48.18	58.02	9.84	N	gnd
0.61484	36.75	56.00	19.25	N	gnd
1.43906	32.96	56.00	23.04	N	gnd
3.50937	35.30	56.00	20.70	N	gnd
4.11875	34.90	56.00	21.10	N	gnd

Frequency MHz	AV Level dBµV	AV Limit dBµV	AV Delta dB	Phase -	PE -
0.29062	26.94	50.51	23.57	N	gnd
0.39218	43.08	48.02	4.94	N	gnd
0.61484	28.52	46.00	17.48	N	gnd
1.43906	26.10	46.00	19.90	N	gnd
3.50937	27.46	46.00	18.54	N	gnd
4.11875	27.00	46.00	19.00	N	gnd

N Line

Conducted Emission from 150 KHz to 30 MHz

TA Technology (Shanghai) Co., Ltd. Test Report

Report No.: RXA1407-0191RF03

Page 88of 93

4. Main Test Instruments

No.	Name	Type	Manufacturer	Serial Number	Calibration Date	Valid Period
01	BT Base Station Simulator	CBT	R&S	100271	2014-05-26	One year
02	Loop Antenna	FMZB1516	SCHWARZBECK	237	2014-05-26	Two years
03	EMI Test Receiver	ESCS30	R&S	100138	2014-01-14	One year
04	LISN	ENV216	R&S	101171	2014-04-11	One year
05	EMI Test Receiver	ESCI	R&S	100948	2014-05-26	One year
06	TRILOG Broadband Antenna	VULB 9163	Schwarzbeck	9163-201	2013-06-19	Three years
07	Double Ridged Waveguide Horn Antenna	HF907	R&S	100126	2012-07-02	Three years
08	PSG Analog Signal Generator	E8257D	Agilent	MY49281101	2014-05-26	One year
09	ESG Vector Signal Generator	E4438C	Agilent	MY49070900	2014-05-26	One year
10	Spectrum Analyzer	E4445A	Agilent	MY46181146	2014-05-26	One year
11	Power Splitter	SHX-GF2-2-13	Hua Xiang	10120101	NA	NA
12	MOB COMMS DC SUPPLY	66319D	Agilent	MY43004105	2014-05-26	One year
13	Power Sensor	E9304A	Agilent	MY50220022	2014-05-26	One year
14	Power Meter	E4418B	Agilent	MY50000623	2014-05-26	One year
15	Vibration table	ESS-050-120	dongling	D1007126	2013-08-22	Three years
16	Spectrum Analyzer	FSV30	R&S	100815	2014-05-26	One year
17	Standard Gain Horn	3160-09	ETS-Lindgren	00102644	2012-05-20	Three years

*****END OF REPORT *****

ANNEX A: EUT Appearance and Test Setup

A.1 EUT Appearance



a: EUT



b: Battery

**TA Technology (Shanghai) Co., Ltd.
Test Report**

Report No.: RXA1407-0191RF03

Page 90 of 93



c: Adapter



Earphone 1

TA Technology (Shanghai) Co., Ltd.
Test Report

Report No.: RXA1407-0191RF03

Page 91 of 93



Earphone 2

d.Earphone

Picture 1 EUT

A.2 Test Setup

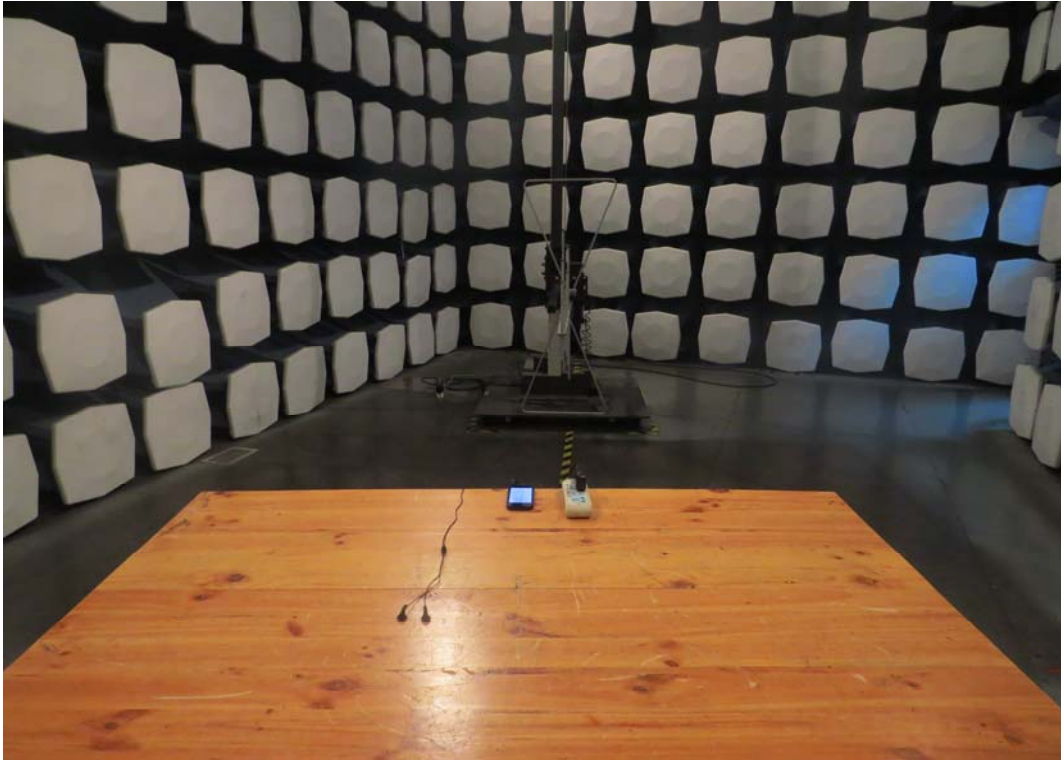

Below 1GHz



Above 1GHz

Picture 2 Radiated Emission Test Setup

**TA Technology (Shanghai) Co., Ltd.
Test Report**

Report No.: RXA1407-0191RF03

Page 93 of 93

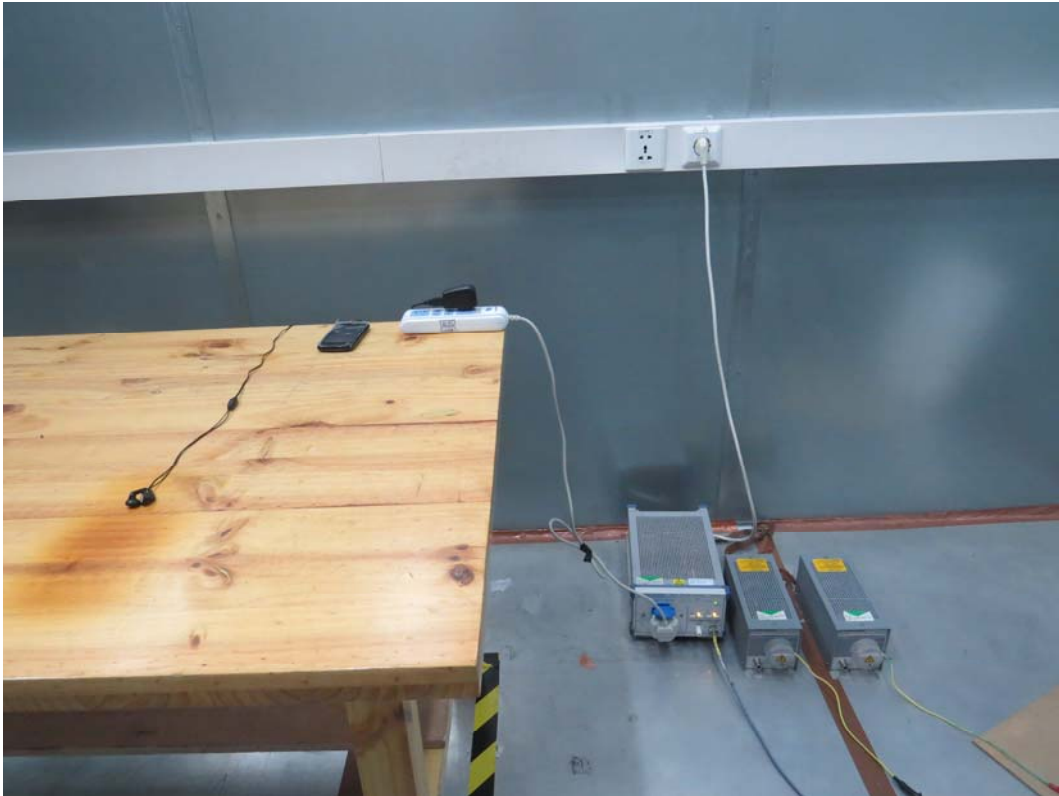

Picture 3 Conducted Emission Test Setup