



FCC 47 CFR PART 24 SUBPART E

TEST REPORT

For

Applicant : Haier Telecom (Qingdao) Co., Ltd.

Address : No.1,Haier Road,Haier information Property Zone, Qingdao,
P.R.China

Product Name : GSM Mobile Phone

Model Name : HG-M200+

Brand Name : Haier

FCC ID : SG71311HGM200PLUS

Report No. : STS131110F3

Date of Issue : November 20,2013

Issued by : Shenzhen Super Test Service Technology Co., Ltd.

Address : No.5, Langshan 2nd Rd., North Hi-Tech Industrial Park ,
Nanshan, Shenzhen, Guangdong ,China

Tel : 86-755-2795 8522

Fax : 86-755-2795 8022

The report consists 39 pages in total. It may be duplicated completely for legal use with the approval of the applicant. It should not be reproduced except in full, without the written approval of our laboratory. The client should not use it to claim product endorsement by STS. The test results in the report only apply to the tested sample. The test report shall be invalid without all the signatures of testing engineers, reviewer and approver.

TABLE OF CONTENTS

1. VERIFICATION OF CONFORMITY..... 3

2. GENERAL INFORMATION..... 5

2.1 Product Information..... 5

2.2 Objective..... 6

2.3 Test Standards and Results..... 6

2.4 Environmental Conditions..... 6

3. TEST FACILITY..... 7

4. TEST EQUIPMENT LIST..... 8

5. 47 CFR Part 2, Part 24E Requirements..... 9

5.1 General Information..... 9

5.1.1 Conducted Related Tests..... 9

5.1.2 Radiated Power and Spurious Emission Tests..... 10

5.1.3 Frequency Stability Test..... 11

5.1.4 Test Mode Description..... 11

6. FREQUENCIES..... 12

6.1. Requirement..... 12

6.2 Test Procedure..... 12

6.3 Test Result..... 12

7. Conducted RF Output Power..... 14

7.1 Requirement..... 14

7.2 Test Procedure..... 14

7.3 Test Result..... 14

8. OCCUPIED BANDWIDTH..... 17

8.1 Occupied Bandwidth Definition..... 17

8.2 Test Procedure..... 17

8.3 Test Result..... 17

9. CONDUCTED SPURIOUS EMISSION..... 21

9.1 Requirement..... 21

9.2 Test Procedure..... 21

9.3 Test Result..... 22

10. Transmitter Radiated Power (EIRP/ERP)..... 27

10.1 Requirement..... 27

10.2 Test Procedure..... 27

10.3 Test Result..... 27

11. Radiated Spurious Emission..... 28

11.1 Requirement..... 28

11.2 Test Procedure.....28

11.3 Test Result.....28

12. Frequency Stability.....29

12.1 Frequency Stability Requirement.....29

12.2 Test Procedure.....29

12.3 Test Result.....30

APPENDIX 1.....31

PHOTOGRAPHS OF EUT.....31

1. VERIFICATION OF CONFORMITY

Equipment Under Test: GSM Mobile Phone
Brand Name: Haier
Model Number: HG-M200+
Series Model Name: N/A
Series Model Difference description: N/A
FCC ID: SG71311HGM200PLUS
Applicant: Haier Telecom (Qingdao) Co., Ltd.
 No.1,Haier Road,Haier information Property Zone,Qingdao,P.R.China
Manufacturer: Haier Telecom (Qingdao) Co., Ltd.
 No.1,Haier Road,Haier information Property Zone,Qingdao,P.R.China
Technical Standards: 47 CFR Part 2
 47 CFR Part 24 Subpart E
File Number: STS131110F2
Date of test: November 11,2013-November 20,2013
Deviation: None
Condition of Test Sample: Normal
Test Result: PASS

The above equipment was tested by Shenzhen Super Test Service Technology Co., Ltd. for compliance with the requirements set forth in FCC rules and the Technical Standards mentioned above. This said equipment in the configuration described in this report shows the maximum emission levels emanating from equipment and the level of the immunity endurance of the equipment are within the compliance requirements.

The test results of this report relate only to the tested sample identified in this report.

Tested by (+ signature): Petter Ping
 Petter Ping November 20,2013

Review by (+ signature): July Wen
 July Wen November 20,2013

Approved by (+ signature): Terry Yang
 Terry Yang November 20,2013

2. GENERAL INFORMATION

2.1 Product Information

| EUT1- Mobile Phone | |
|----------------------------|---|
| Description: | GSM Mobile Phone |
| Model Name: | HG-M200+ |
| IMEI No.: | N/A |
| Frequency Range: | GSM 850: 824.2-848.8MHz GSM1900:1850.2-1909.8MHz Bluetooth:2402-2480MHz |
| Hardware Version: | P512A MB PCB_V1.1 |
| Software Version: | PL-P512A_UITIME_G73B_60D_11B_32M_V0.1 |
| EUT2- Battery | |
| Description: | Lithium-ion Battery |
| Model Name: | M200+ |
| Brand Name: | Haier |
| Manufacturer: | JIANGXI HONGSING CNCRGY CO ., LTD |
| Capacitance: | 650 mAh |
| Rated Voltage: | 3.7V |
| Charge Limit: | 4.2V |
| EUT3 – Power Supply | |
| Description: | Travel Charger |
| Model Name: | M200+ |
| Brand Name: | Haier |
| Manufacturer: | Dongguan Qin Ling Electronic Technology Co., Ltd. |
| Rated Input: | AC 100-240V, 50/60Hz, 0.1A |
| Rated Output: | DC 5V, 0.5A |
| Length of USB cable: | 1.0m |

NOTE:

1. The EUT is a Mobile Station, here only PCS 1900MHz band was tested in this report.
2. The normal, high and low voltage supply for the Battery of the EUT is separately 3.7V, 4.2V and 3.6V, which are specified by the applicant.
3. Please refer to Appendix 2 for the photographs of the EUT. For a more detailed features description about the EUT, please refer to User's Manual

2.2 Objective

The objective of the report is to perform tests according to 47 CFR Part 2, Part 24 for FCC ID Certification:

| No. | Identity | Document Title |
|-----|-------------------------------------|---|
| 1 | 47 CFR Part 2 (10-1-11 Edition) | Frequency Allocations and Radio Treaty Matters; General Rules and Regulations |
| 2 | 47 CFR Part 24 (10-1-11 Edition) | Personal Communications Services |

2.3 Test Standards and Results

Test items and the results are as bellow:

| No. | Rules | Test Type | Result | Date of Test |
|-----|-------------------------------|---|--------|--------------|
| 1 | §2.106 §24.229 | Frequencies | PASS | 2013-11-14 |
| 2 | §2.1046 | Conducted RF Output Power at Antenna Terminal | PASS | 2013-11-14 |
| 3 | §2.1049 | Occupied Bandwidth | PASS | 2013-11-14 |
| 4 | §2.1051 §2.1057 §24.238 | Conducted Spurious Emission at Antenna Terminal | PASS | 2013-11-14 |
| 5 | §24.232 | Transmitter Radiated Power (EIPR/ERP) | PASS | 2013-11-14 |
| 6 | §2.1053 §2.1057 §24.238 | Radiated Spurious Emission | PASS | 2013-11-14 |
| 7 | §2.1055 §24.235 | Frequency Stability | PASS | 2013-11-14 |

Note: 1. The test result judgment is decided by the limit of measurement standard
 2. The information of measurement uncertainty is available upon the customer's request.

2.4 Environmental Conditions

During the measurement the environmental conditions were within the listed ranges:

- Temperature: 15-35°C
- Humidity: 30-60 %
- Atmospheric pressure: 86-106 kPa

3. TEST FACILITY

| | |
|-----------------------|---|
| Test Site: | Compliance Certification Services Inc. (Kun shan) Laboratory |
| Location: | No.10 Weiye Rd, Innovation park, Eco&Tec,Development Zone, Kunshan City, Jiangsu, China |
| Description: | <p>There is one 3m semi-anechoic an area test sites and two line conducted labs for final test. The Open Area Test Sites and the Line Conducted labs are constructed and calibrated to meet the FCC requirements in documents ANSI C63.4 and CISPR 16 requirements.</p> <p>The FCC Registration Number is 238958.</p> <p>The CNAS Registration Number is CNAS L4354.</p> |
| Site Filing: | The site description is on file with the Federal Communications Commission, 7435 Oakland Mills Road, Columbia, MD 21046. |
| Instrument Tolerance: | All measuring equipment is in accord with ANSI C63.4:2009 and CISPR 16 requirements that meet industry regulatory agency and accreditation agency requirement. |
| Ground Plane: | Two conductive reference ground planes were used during the Line Conducted Emission, one in vertical and the other in horizontal. The dimensions of these ground planes are as below. The vertical ground plane was placed distancing 40 cm to the rear of the wooden test table on where the EUT and the support equipment were placed during test. The horizontal ground plane projected 50 cm beyond the footprint of the EUT system and distanced 80 cm to the wooden test table. For Radiated Emission Test, one horizontal conductive ground plane extended at least 1m beyond the periphery of the EUT and the largest measuring antenna, and covered the entire area between the EUT and the antenna. |

4. TEST EQUIPMENT LIST

Instrumentation: The following list contains equipment used at CCS for testing. The equipment conforms to the CISPR 16-1 / ANSI C63.2 Specifications for Electromagnetic Interference and Field Strength Instrumentation from 10 kHz to 1.0 GHz or above.

| Name of Equipment | Manufacturer | Model | Serial Number | Calibration Due | calibration interval |
|---------------------|-------------------|------------|---------------|-----------------|----------------------|
| Spectrum Analyzer | Agilent | E4446A | MY44020154 | 2014-5-12 | 1 year |
| EMI Test Receiver | R&S | ESCI | 1166.5950.03 | 2014-8-13 | 1 year |
| Pre-Amplifier | Miteq | NSP4000-NF | 870629 | 2014-5-12 | 1 year |
| Bilog Antenna | Sunol | JB1 | A110204-2 | 2014-5-12 | 1 year |
| Horn-antenna | SCHWARZBECK | BBHA9120D | D:266 | 2014-6-7 | 1 year |
| Horn-antenna | SCHWARZBECK | BBHA9170 | D:171 | 2014-4-28 | 1 year |
| Loop-antenna | ZHINAN | ZN30900A | N/A | 2014-6-7 | 1 year |
| Turn Table | CT | CT123 | 4165 | N.C.R | 1 year |
| Antenna Tower | CT | CTERG23 | 3256 | N.C.R | 1 year |
| Controller | CT | CT100 | 95637 | N.C.R | 1 year |
| EMI TEST RECEIVER | R&S | ESCI | 100781 | 2014-3-14 | 1 year |
| V (V-LISN) | R&S | ENV216 | 101604 | 2014-5-21 | 1 year |
| Pulse Limiter | R&S | ESH3-Z2 | 100524 | 2014-9-24 | 1 year |
| Temperature Chamber | Guangzhou Gongwen | GDS-250 | N/A | 2014-9-24 | 1 year |
| Test Software | EZ-EMC | | | | |

NOTE: Equipments listed above have been calibrated and are in the period of validation.

5. 47 CFR Part 2, Part 24E Requirements

5.1 General Information

5.1.1 Conducted Related Tests

Based on ANSI/TIA-603-C-2004

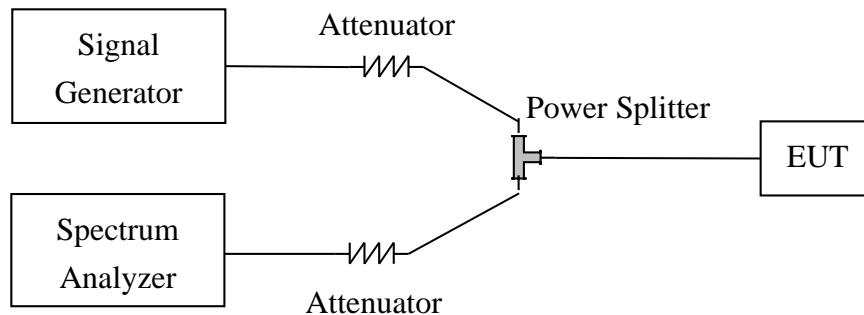

1. The EUT is coupled to the Spectrum Analyzer and the System Simulator with the suitable Attenuators through the Power Splitter; the path loss is calibrated to correct the reading.
2. The EUT is configured here as MS + Battery.
3. Set the spectrum analyzer to measure peak hold with the required settings.
4. Set the signal generator to a known output power and record the path loss in dB (LOSS) for frequencies up to the tenth harmonic of the EUT's carrier frequency. $LOSS = \text{Generator Output Power (dBm)} - \text{Analyzer reading (dBm)}$.
5. Replace the signal generator with the EUT.
6. Adjust the settings of the Digital Radio communication Tester (DRT) to set the EUT to its maximum power at the required channel.
7. Set the spectrum analyzer to measure peak hold with the required settings. Offset the spectrum analyzer reference level by the path loss measured above.
8. Measure and record all spurious emissions up to the tenth harmonic of the carrier frequency.
9. Measurements are to be performed with the EUT set to the low, middle and high channel of each frequency band.
10. If necessary steps 7 and 8 may be performed with the spectrum analyzer set to average detector.

Note: Step 4 above is performed prior to testing and LOSS is recorded by test software. Steps 3, 7, and 8 above are performed with test software.

5.1.2 Radiated Power and Spurious Emission Tests

Based on ANSI/TIA-603-C-2004

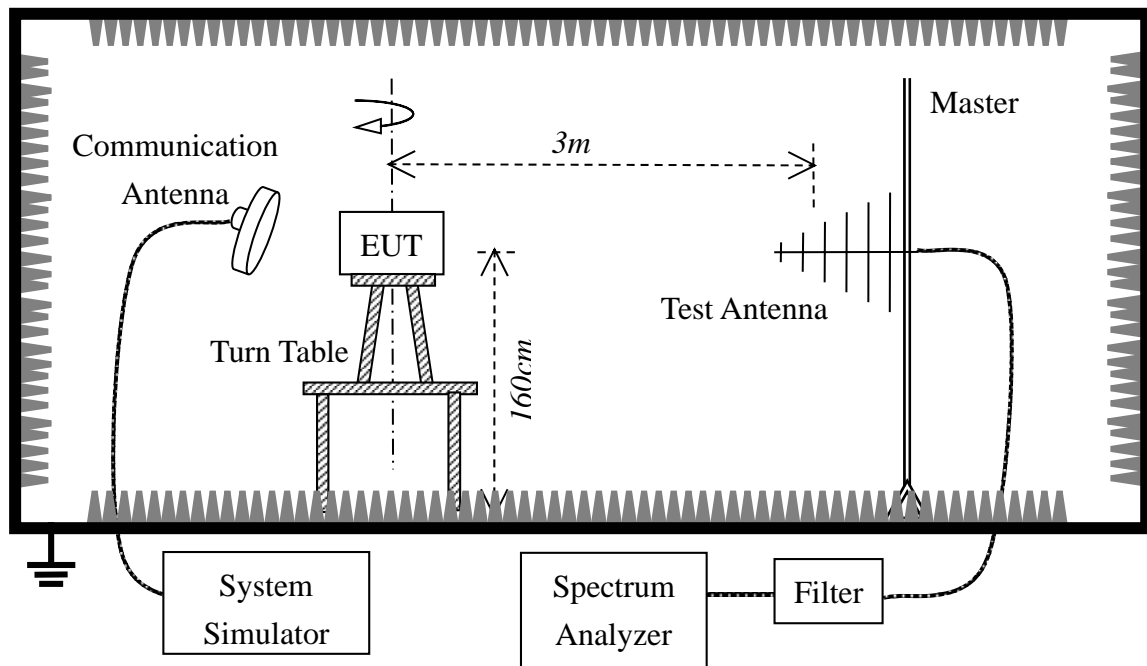

1. The test is performed in a full-Anechoic Chamber; the air loss of the site and the factors of the test system are pre-calibrated using the substitution method.
2. Connect the equipment as shown in the above diagram with the EUT'S antenna in a vertical orientation.
3. Adjust the setting of System Simulator to set the EUT to its maximum power at the require channel.
4. Set the Spectrum Analyzer to the channel frequency, set the analyzer to measure peak hold with the required setting.
5. Rotate the EUT 360 degree, recorded the peak level in dBm(LVL).
6. Replace the EUT with a vertically polarized half wave dipole or known gain antenna. The center of the antenna should be at the same location as the center of the EUT's antenna.
7. Connect the antenna to a signal generator with known output power and record the path loss in dB (Loss),
 $Loss = \text{Generator Output Power(dBm)} - \text{Spectrum Analyzer reading Power(dBm)}$.
8. Determine the ERP using the following equation:
 $ERP(\text{dBm}) = LVL(\text{dBm}) + Loss(\text{dB})$
9. Determine the EIRP using the following equation:
 $EIRP(\text{dBm}) = ERP(\text{dBm}) + 2.14(\text{dB})$
10. Measurements are to be performed with the EUT set to the low, middle and high channel of each frequency band.

Note: Steps 6 and 7 above are performed prior to setting and Loss is recorded by test software.

5.1.3 Frequency Stability Test

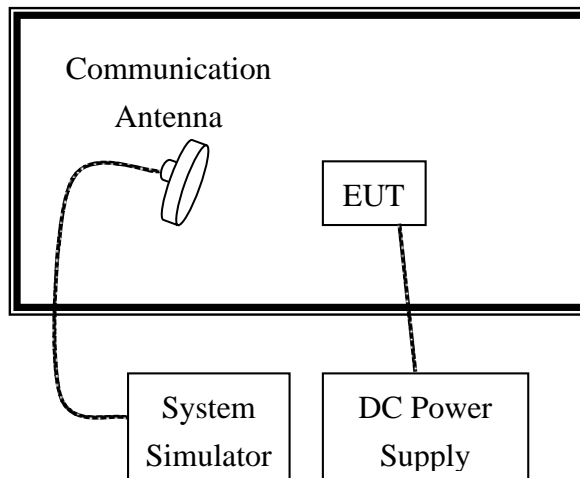

1. The test is performed in a Temperature Chamber.
2. The EUT is configured as MS + DC Power Supply.
3. The BCCH number of the SS used here is 520.

5.1.4 Test Mode Description

SIM 1 and SIM 2 are tested during all the items, According to the test data, we got the worst mode is SIM1, So we only put the worst data on the report.

6. FREQUENCIES

6.1. Requirement

According to FCC §24.229, the frequencies available in the Broadband PCS services are listed as below, in accordance with the frequency allocations table of FCC §2.106.

(a) The following frequency blocks are available for assignment on an MTA basis:

Block A: 1850 - 1865MHz paired with 1930 - 1945MHz;

Block B: 1870 - 1885MHz paired with 1950 - 1965MHz.

(b) The following frequency blocks are available for assignment on a BTA basis:

Block C: 1895 - 1910 MHz paired with 1975 - 1990MHz;

Block D: 1865 - 1870 MHz paired with 1945 - 1950MHz;

Block E: 1885 - 1890 MHz paired with 1965 - 1970MHz;

Block F: 1890 - 1895 MHz paired with 1970 - 1975MHz.

6.2 Test Procedure

1. Perform test system setup as section 5.1.1.
2. The resolution bandwidth of the Spectrum Analyzer is set to at least one percent of the emission bandwidth of the fundamental emission of the transmitter, e.g. for GSM modulated signal (here used): $RBW=VBW=3kHz$, for CDMA modulated signal: $RBW=VBW=30kHz$.
3. The lowest and the highest channels are selected to perform tests respectively. Set the TCH number to 512 via the SS as the lowest channel.
4. Set the frequency range of the Spectrum Analyzer suitably to capture the waveform; search peak and mark it; finally record the plot.
5. Set the TCH number to 810 as the highest channel, then repeat step 4.

6.3 Test Result

| Frequency Band | Channel Number | Frequency (MHz) |
|---------------------------|----------------|-----------------|
| GSM1900 (GPRS class 8) | 512 | 1850.215 |
| | 810 | 1909.800 |

1. Plot when the TCH number set to 512:

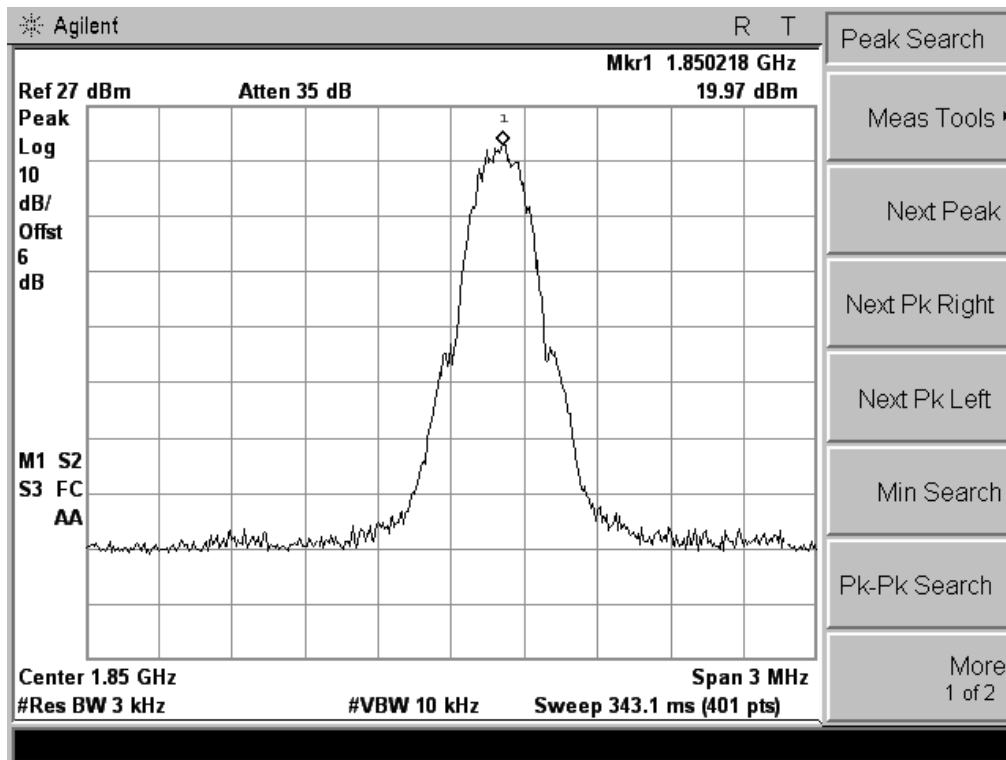

2. Plot when the TCH number set to 810:

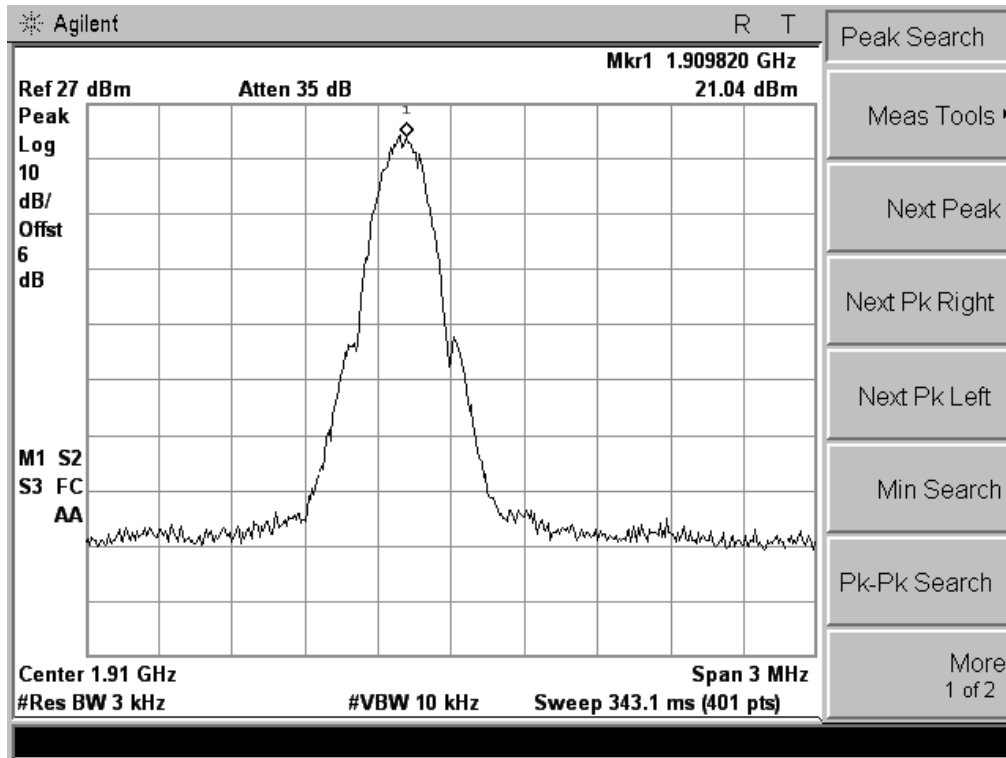

7. Conducted RF Output Power

7.1 Requirement

According to FCC §2.1046(a), for transmitters other than single sideband, independent sideband and controlled carrier radiotelephone, power output shall be measured at the RF output terminals when the transmitter is adjusted in accordance with the tune-up procedure to give the values of current and voltage on the circuit elements specified in §2.1033(c)(8). The electrical characteristics of the radio frequency load attached to the output terminals when this test is made shall be stated.

7.2 Test Procedure

1. Perform test system setup as section 5.1.1 (the radio frequency load attached to the EUT antenna terminal is 50Ω).
2. The resolution bandwidth of the Spectrum Analyzer is set to be comparable to the emission bandwidth of the transmitter, e.g. for GSM modulated signal (here used): RBW=VBW=1MHz, for CDMA modulated signal: RBW=VBW=3MHz.
3. The low, middle and the high channels are selected to perform tests respectively. Set the TCH number to 512 as the low channel.
4. Set the frequency range of the Spectrum Analyzer suitably to capture the waveform; search peak and mark it; finally record the peak and the plot.
5. Set the TCH number to 661 as the middle channel, then repeat step 4.
6. Set the TCH number to 810 as the high channel, then repeat step 4.

7.3 Test Result

| Frequency Band | Channel Number | Frequency (MHz) | Measured Power | | Rated Power | |
|---------------------------|----------------|-----------------|----------------|-------|-------------|---|
| | | | dBm | W | dBm | W |
| GSM1900 (GPRS class 8) | 512 | 1850.2 | 28.51 | 0.710 | 30 | 1 |
| | 661 | 1880.0 | 28.75 | 0.750 | 30 | 1 |
| | 810 | 1909.8 | 29.04 | 0.802 | 30 | 1 |

1. Plot when the TCH number set to 512:

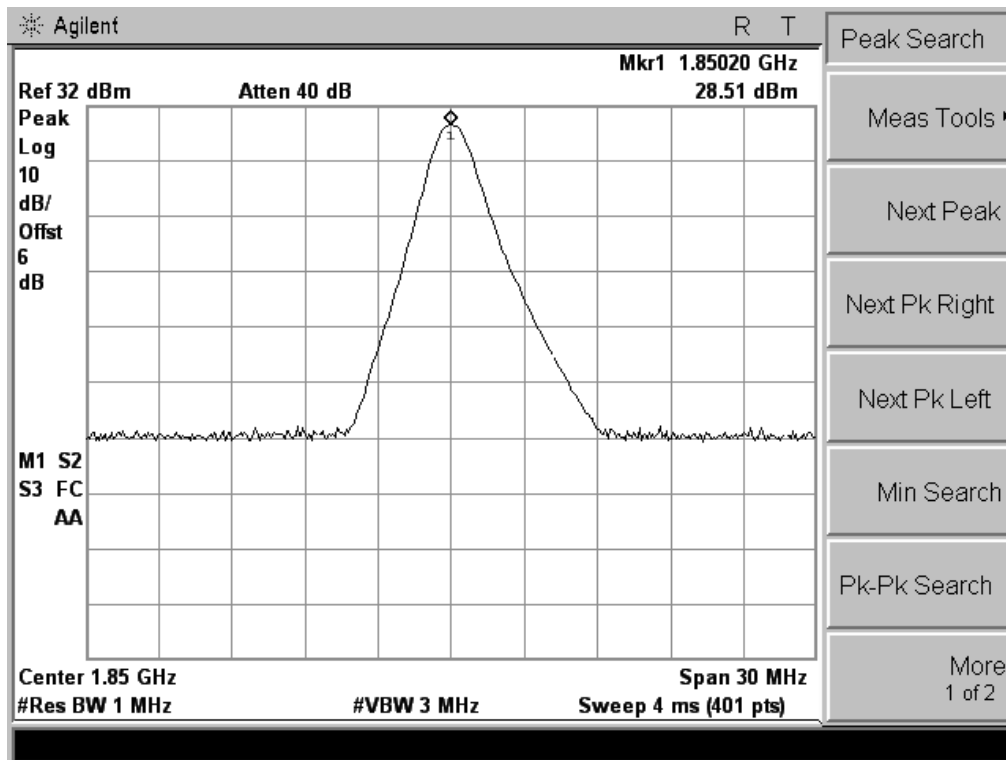

2. Plot when the TCH number set to 661:

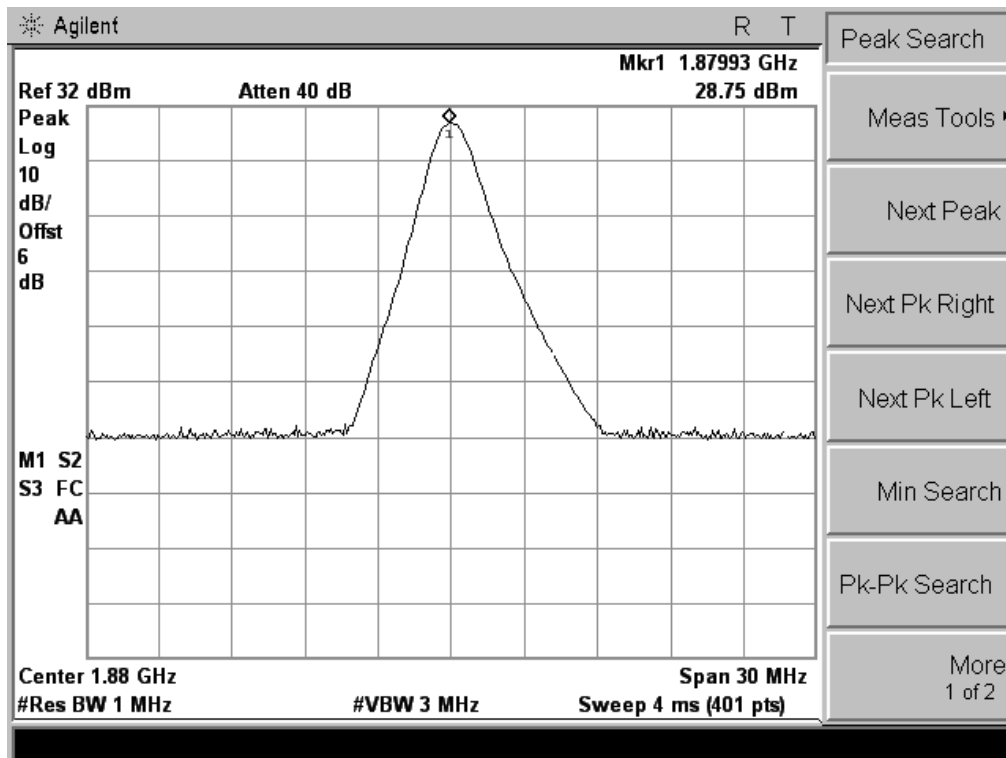

3. Plot when the TCH number set to 810:

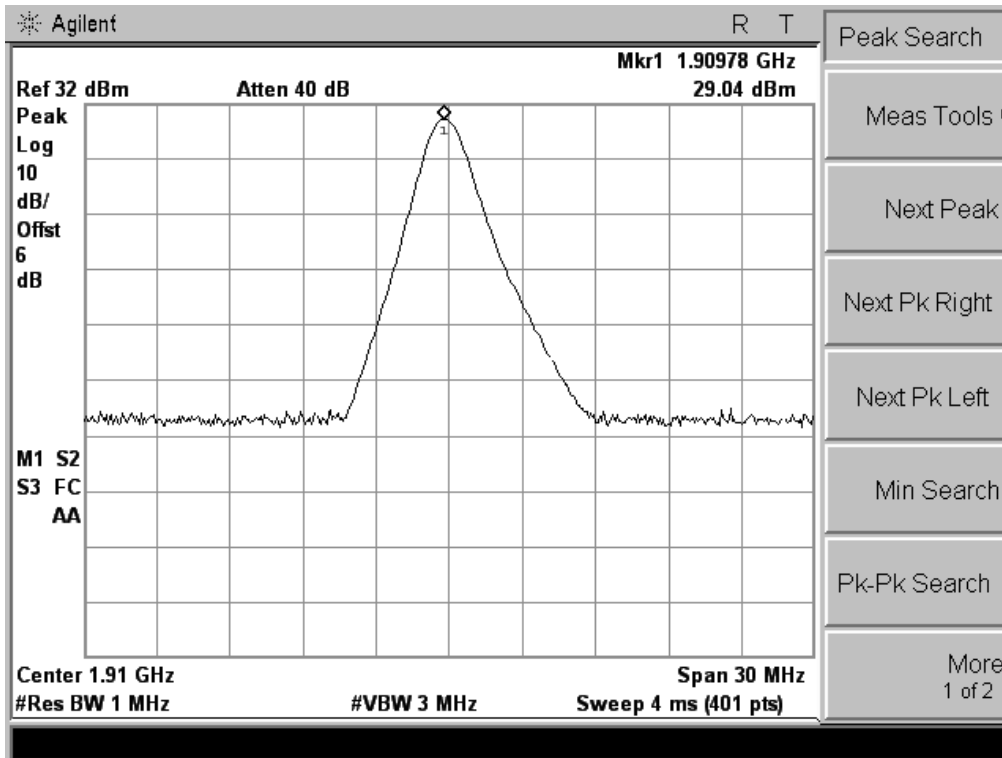

8. OCCUPIED BANDWIDTH

8.1 Occupied Bandwidth Definition

According to FCC §2.1049, the occupied bandwidth is the frequency bandwidth such that, below its lower and above its upper frequency limits, the mean powers radiated are each equal to 0.5 percent of the total mean power radiated by a given emission.

Occupied bandwidth is also known as the 99% emission bandwidth, or 20dB bandwidth ($10 \cdot \log 1\%$ is equal to 20dB) taking the total RF output power as reference.

8.2 Test Procedure

1. Perform test system setup as section 5.1.1
2. The resolution bandwidth of the Spectrum Analyzer is set to at least one percent of the emission bandwidth, e.g. for GSM modulated signal (here used): RBW=VBW=3 kHz, for CDMA modulated signal: RBW=VBW=30 kHz.
3. The low, middle and the high channels are selected to perform tests respectively. Set the TCH number to 512 as the low channel.
4. Set the frequency range of the Spectrum Analyzer suitably to capture the waveform; search peak; make a line whose value is 20dB lower than the peak; mark two points which the line intersected the waveform at; finally record the delta of the two points as the occupied bandwidth and the plot.
5. Set the TCH number to 661 as middle channel, then repeat step 4.
6. Set the TCH number to 810 as high channel, then repeat step 4.

8.3 Test Result

| Band | Channel | Frequency (MHz) | Measured Occupied Bandwidth (kHz) | |
|------------------------|---------|-----------------|-----------------------------------|-------------------------|
| | | | 99% Emission Bandwidth | 26dB Emission Bandwidth |
| GSM1900 (GPRS class 8) | 512 | 1850.2 | 285.0 | 325.0 |
| | 661 | 1880.0 | 288.0 | 320.0 |
| | 810 | 1909.8 | 293.0 | 323.0 |

1. Plot 99% Occupied Bandwidth when the TCH number set to 512:

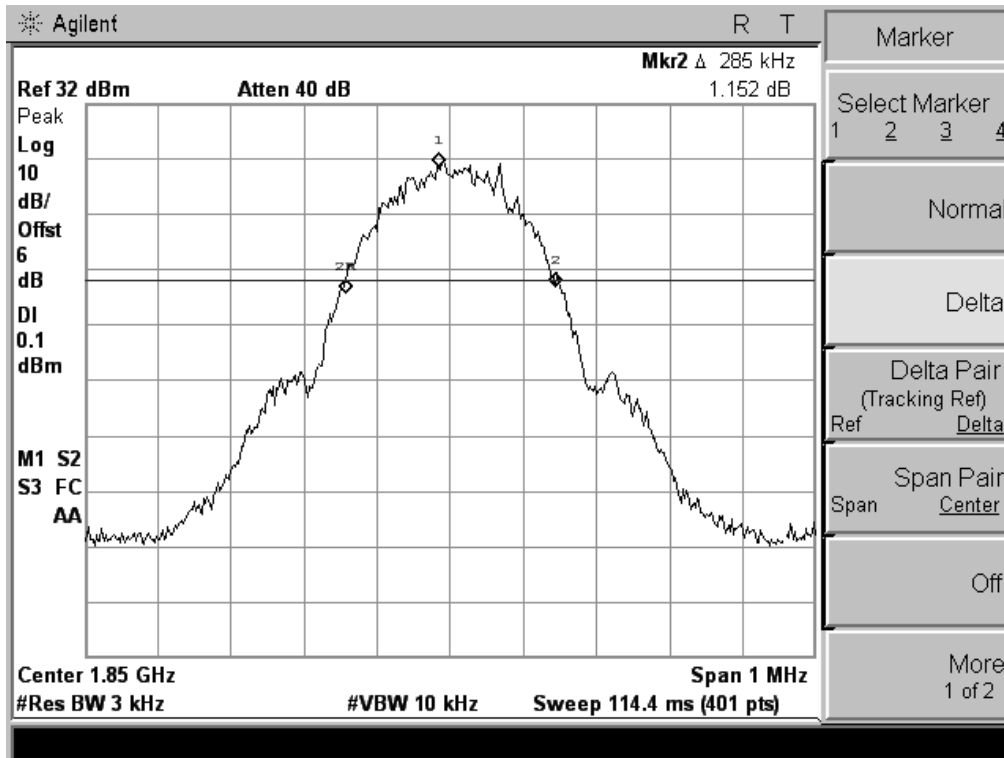

2. Plot 26dB Occupied Bandwidth when the TCH number set to 512:

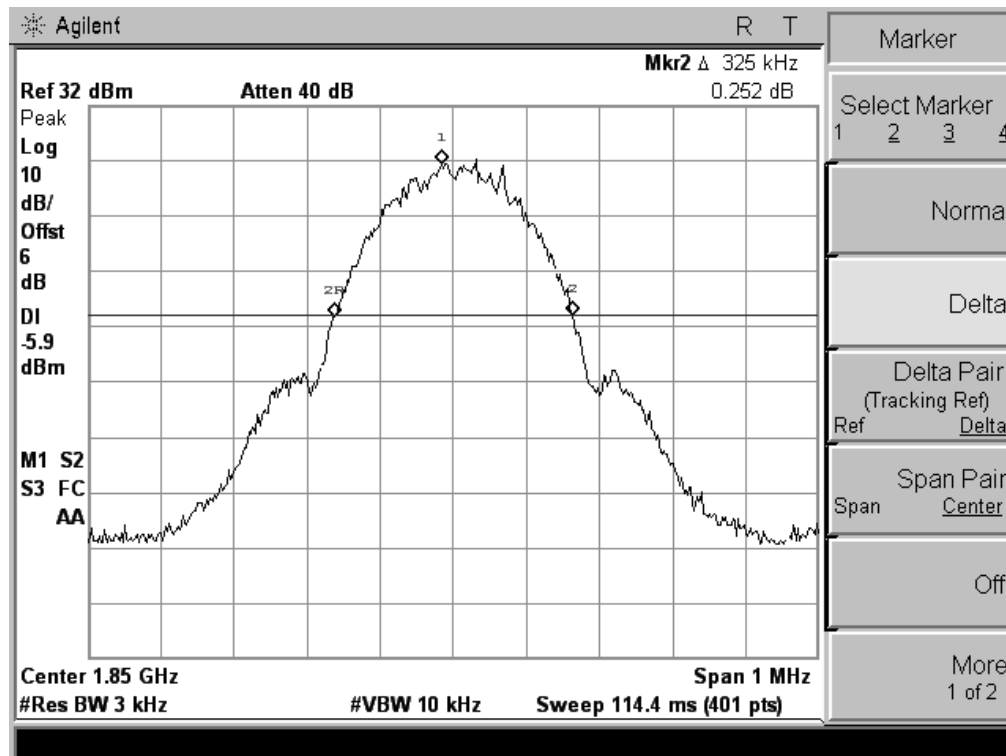

3. Plot 99% Occupied Bandwidth when the TCH number set to 661:

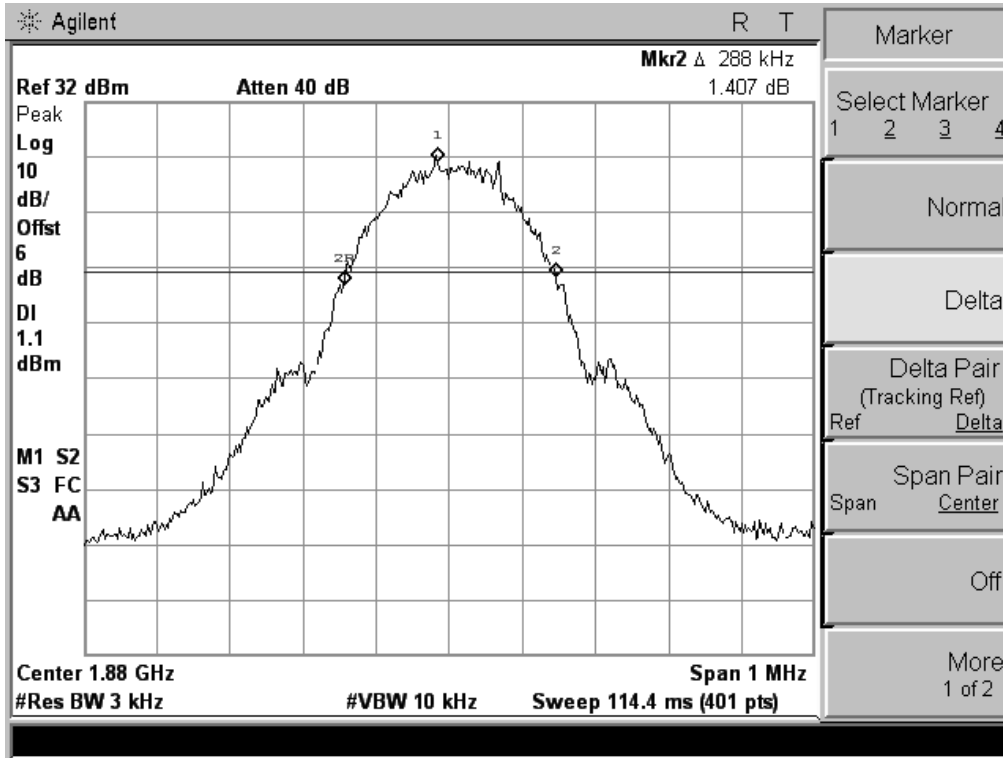

4. Plot 26dB Occupied Bandwidth when the TCH number set to 661:

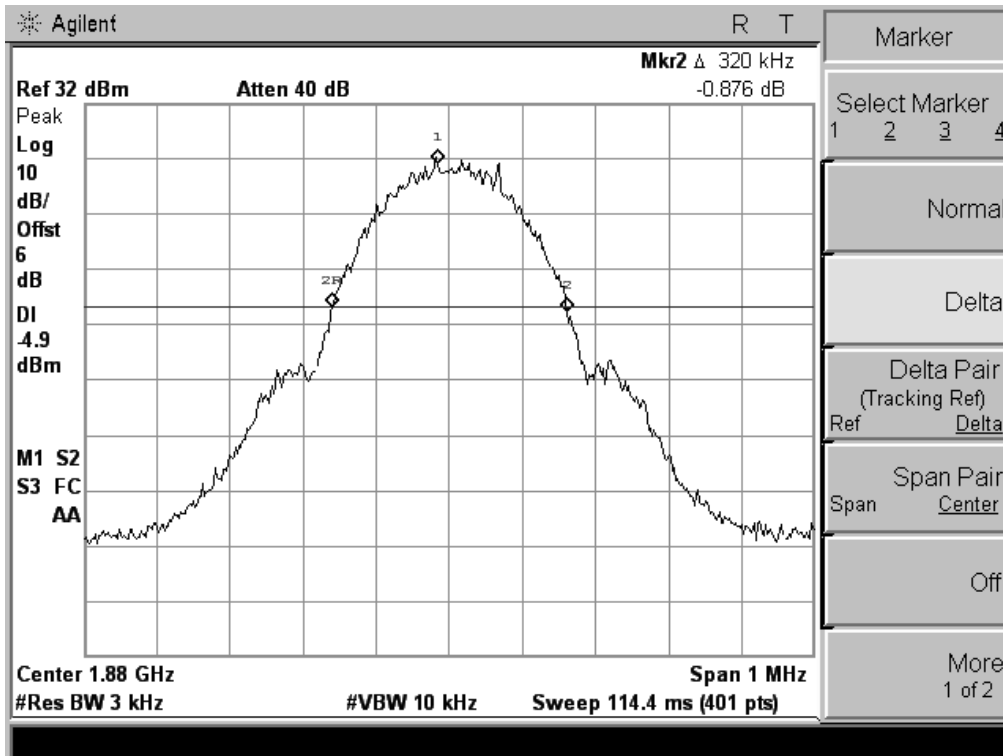

5. Plot 99% Occupied Bandwidth when the TCH number set to 810:

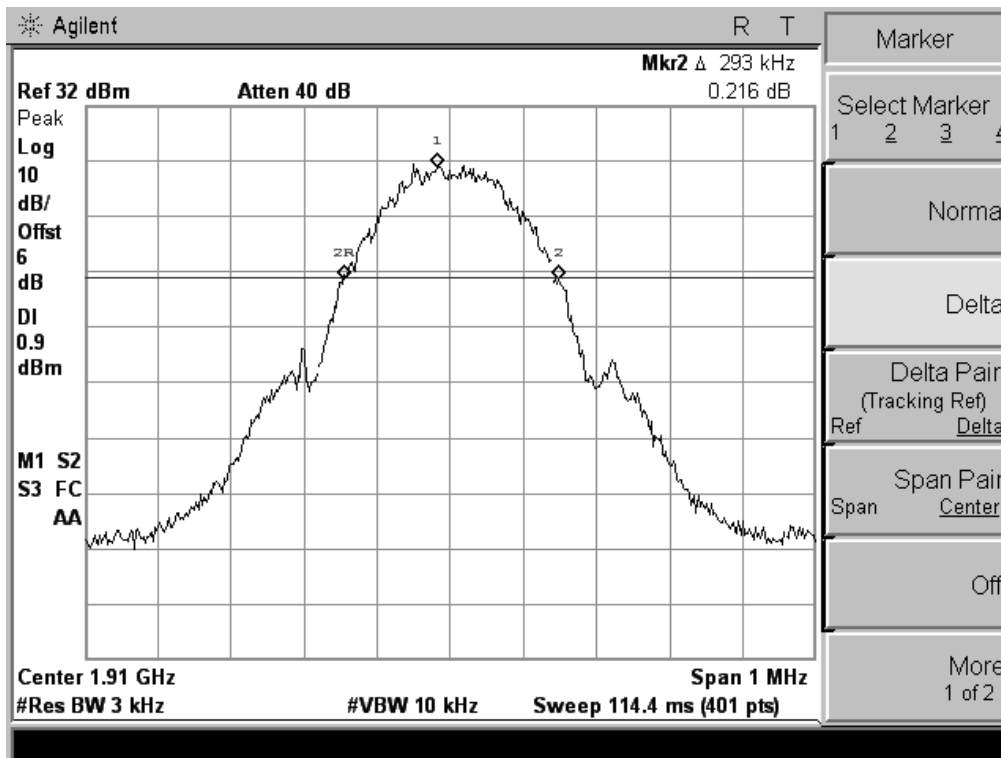

6. Plot 26dB Occupied Bandwidth when the TCH number set to 810:

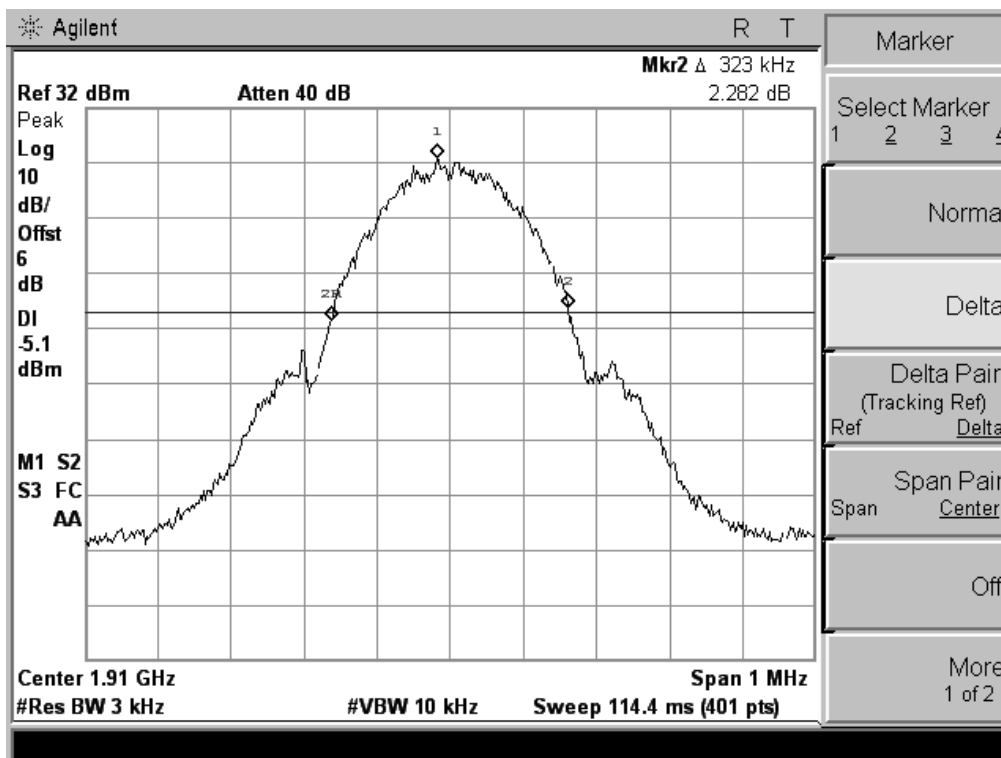

9. CONDUCTED SPURIOUS EMISSION

9.1 Requirement

1. According to FCC §24.238(a), the power of any emission outside of the authorized operating frequency ranges must be attenuated below the transmitting power (P) by a factor of at least $43+10*\log(P)$ dB. This calculated to be -13dBm.
2. According to FCC §24.238(b), in the 1MHz bands immediately outside and adjacent to the frequency block a resolution bandwidth of at least one percent of the emission bandwidth of the fundamental emission of the transmitter may be employed. Thus the 26dB emission bandwidth is measurement for showing compliance at the band-edge.

9.2 Test Procedure

1. Perform test system setup as section section 5.1.1.
2. Make a limit line whose value is -13dBm on the Spectrum Analyzer.
3. The lowest, middle and the highest channels are selected to perform tests respectively. Set the TCH number to 512 as the lowest channel.
4. Set the RBW of the Spectrum Analyzer to 1MHz, and the measuring frequency range from 9kHz to 10th harmonic of the fundamental frequency (here used 26.5GHz); mark the fundamental frequency and the harmonics thereof; finally record the harmonics and the plot. Note, the measuring frequency range can be divided into several parts to perform tests.
5. In the 1MHz bands immediately outside and adjacent to the frequency black, the RBW of the Spectrum Analyzer was set to at least one percent of the emission bandwidth of the fundamental emission of the transmitter, e.g. for GSM modulated signal (here used): RBW=3kHz, for CDMA modulated signal: RBW=30kHz.
6. Set the TCH number to 661 as the middle channel, then repeat step 4.
7. Set the TCH number to 810 as the highest channel, then repeat step 4 and 5.

9.3 Test Result

Table for the Harmonics and Plots for the Spurious Emission

1. Table for GSM1900 the Harmonics:

| No. | Frequency (MHz) | RBW (KHz) | VBW (KHz) | Emission Power (dBm) | Limit (dBm) |
|------------------------------------|-----------------|-----------|-----------|----------------------|-------------|
| TCH number set to 512 (1850.20MHz) | | | | | |
| Form 9KHz to 25000MHz | | | | | |
| 1 | 3720.60 | 1000 | 3000 | -45.93 | -13 |
| 2 | 5550.10 | 1000 | 3000 | -40.40 | -13 |
| 3 | 7420.30 | 1000 | 3000 | -38.19 | -13 |
| TCH number set to 661 (1880.00MHz) | | | | | |
| Form 9KHz to 25000MHz | | | | | |
| 4 | 3770.00 | 1000 | 3000 | -43.86 | -13 |
| 5 | 5640.10 | 1000 | 3000 | -45.81 | -13 |
| 6 | 7550.20 | 1000 | 3000 | -37.24 | -13 |
| TCH number set to 810 (1909.80MHz) | | | | | |
| Form 9KHz to 25000MHz | | | | | |
| 7 | 3850.40 | 1000 | 3000 | -42.84 | -13 |
| 8 | 5720.20 | 1000 | 3000 | -41.78 | -13 |
| 9 | 7630.35 | 1000 | 3000 | -41.67 | -13 |

2. Plot for Spurious Emission:

The measuring frequency range was from 9 kHz to 25GHz, but only the worst (above 1000MHz band) test plots were display as below.

NOTE: The marker points are the Mobile Phone and/or System Simulator transmitting frequencies which should be ignored.

2.1 Plot when the TCH number set to 512:

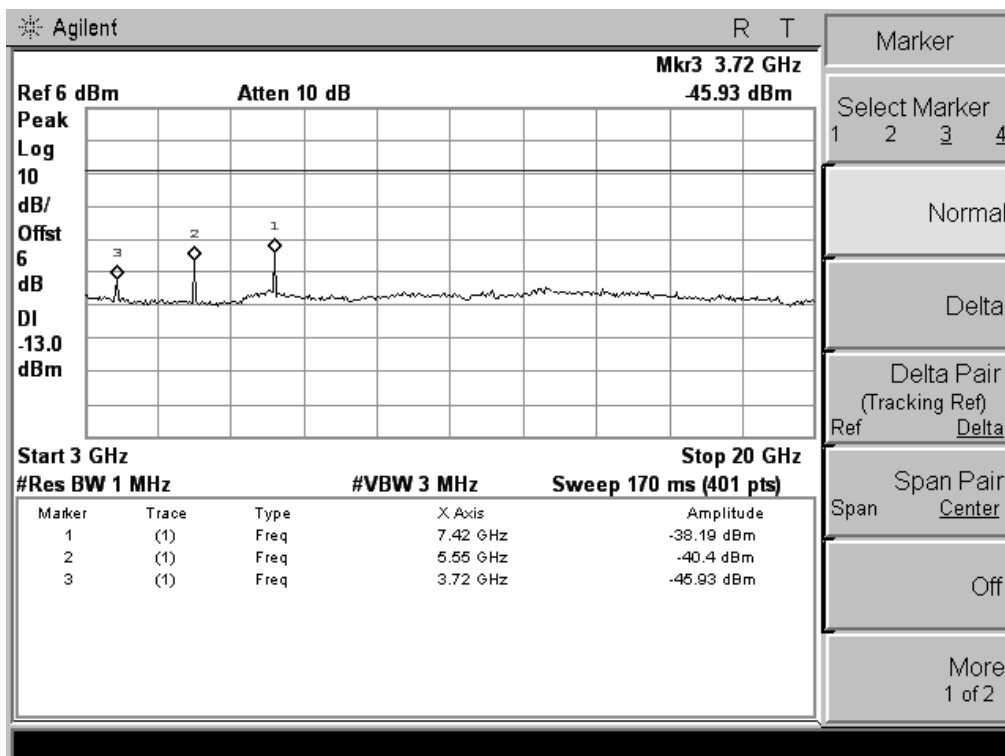
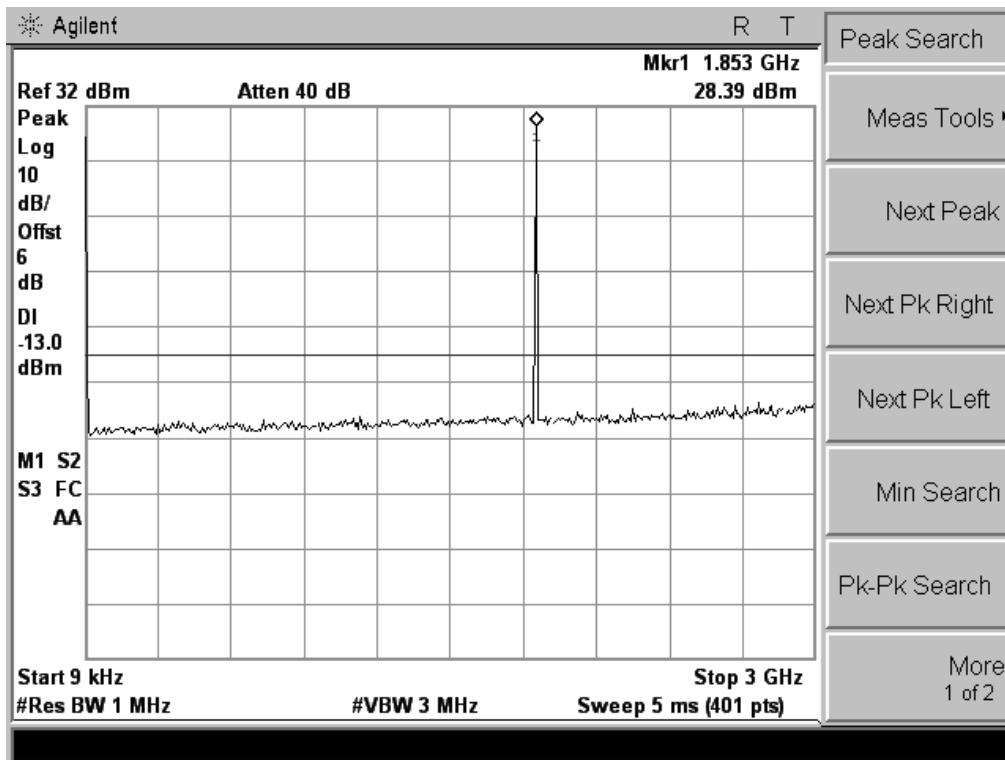

2.2 Plot when the TCH number set to 661:

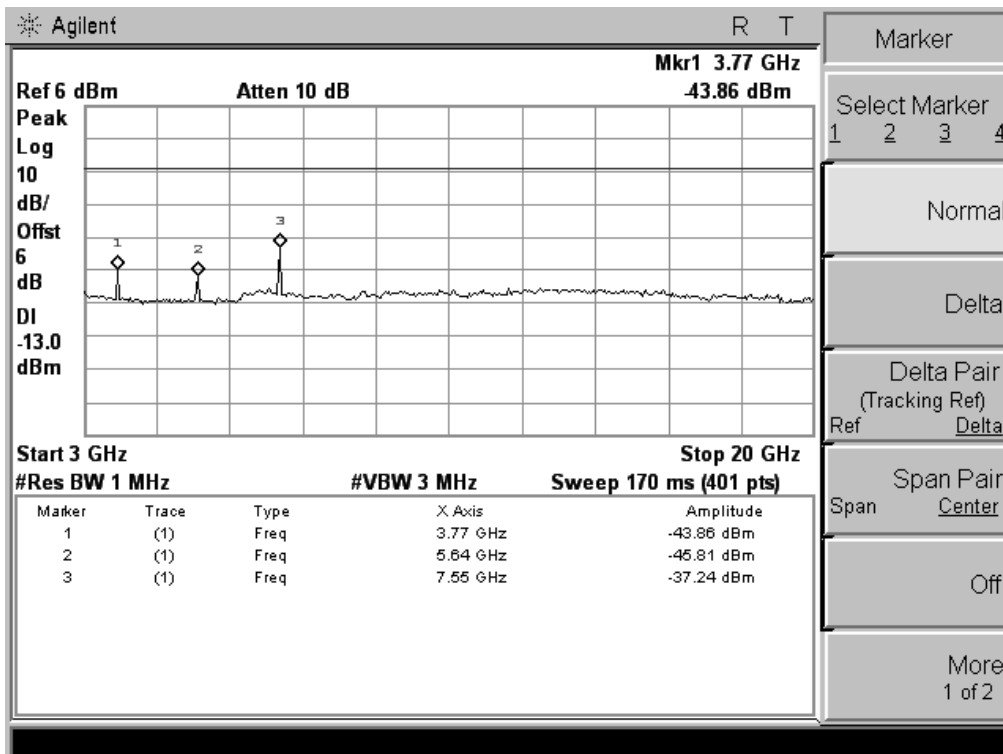
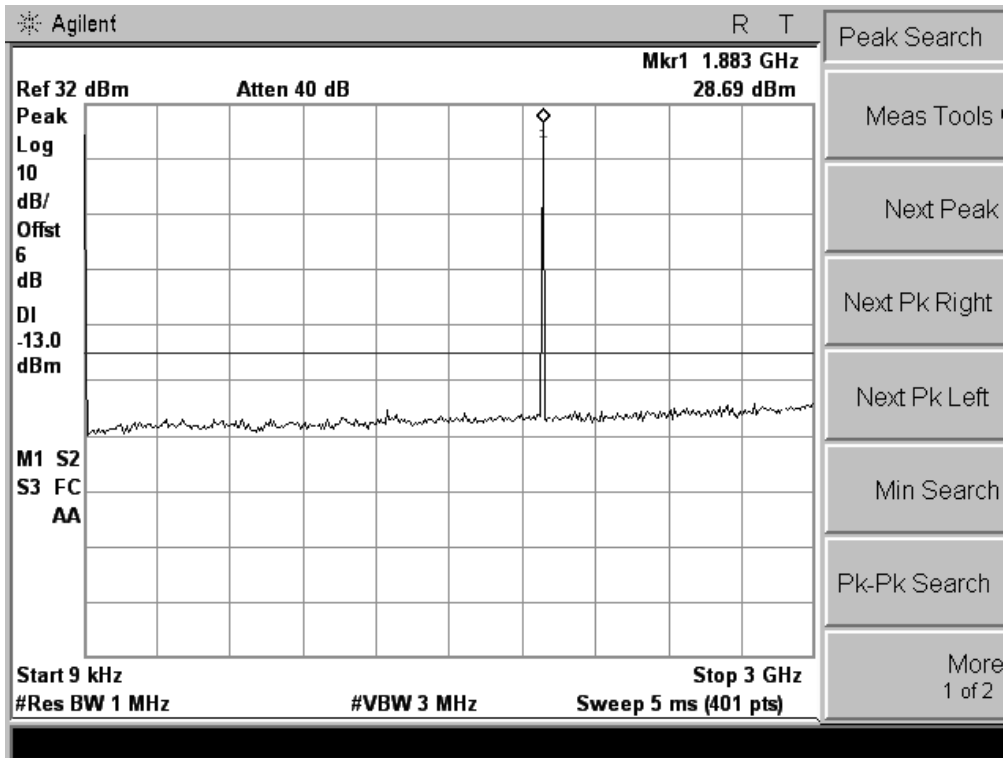

2.3 Plot when the TCH number set to 810:

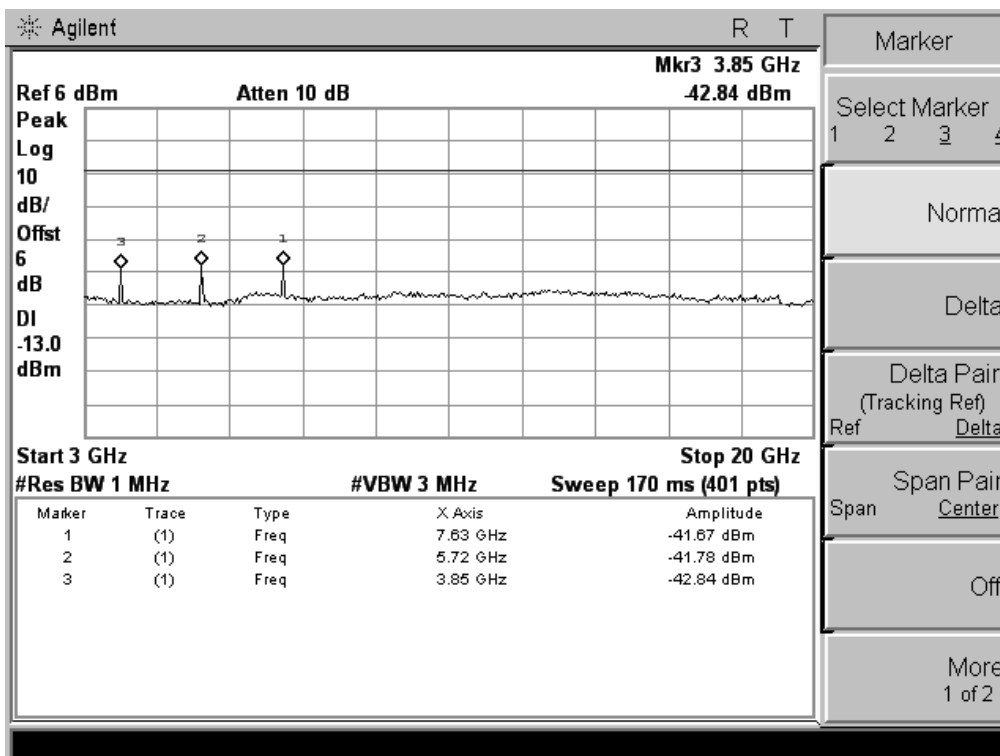
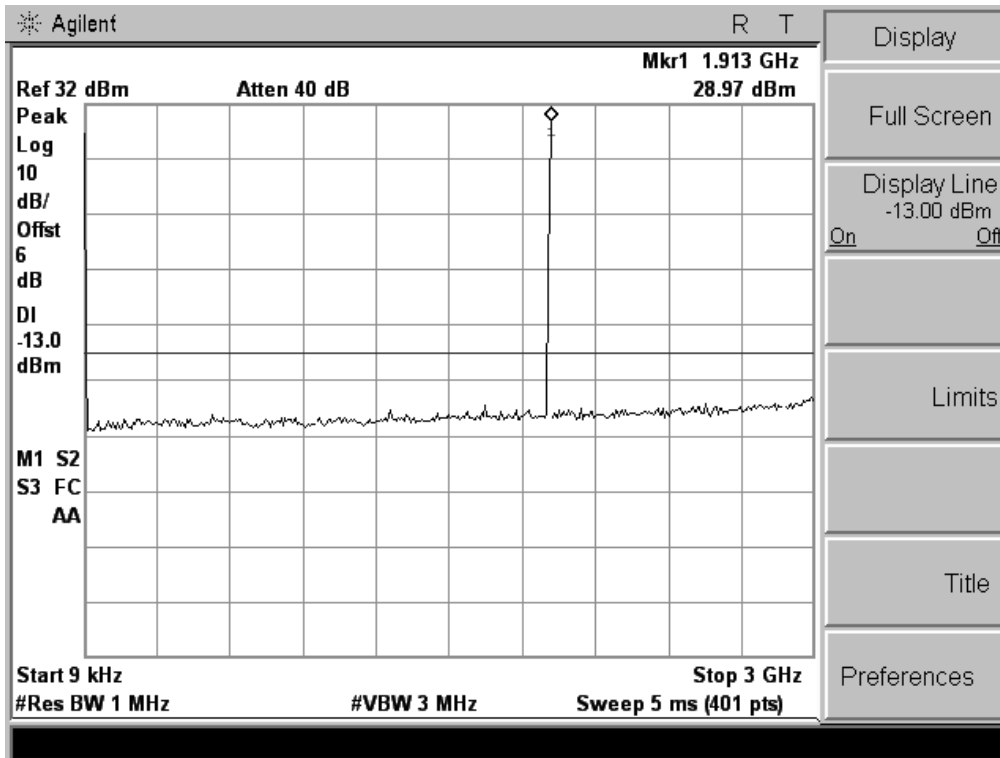

3. Plot for Band-edge

3.1 Plot when the TCH number set to 512:

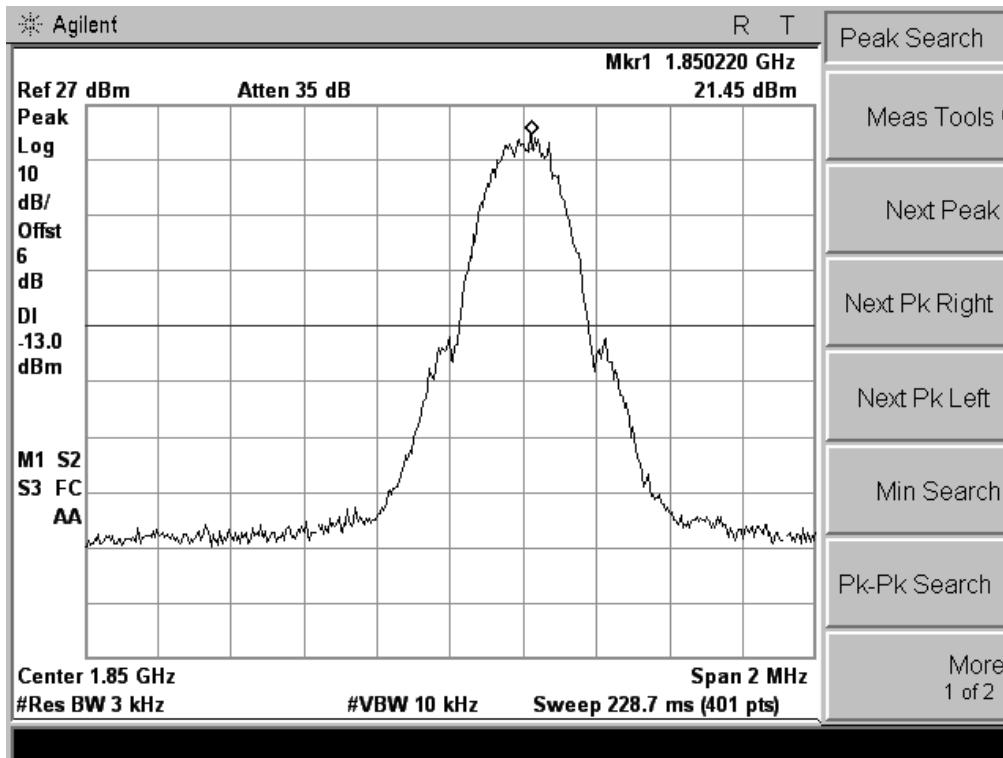

3.2 Plot when the TCH number set to 810:

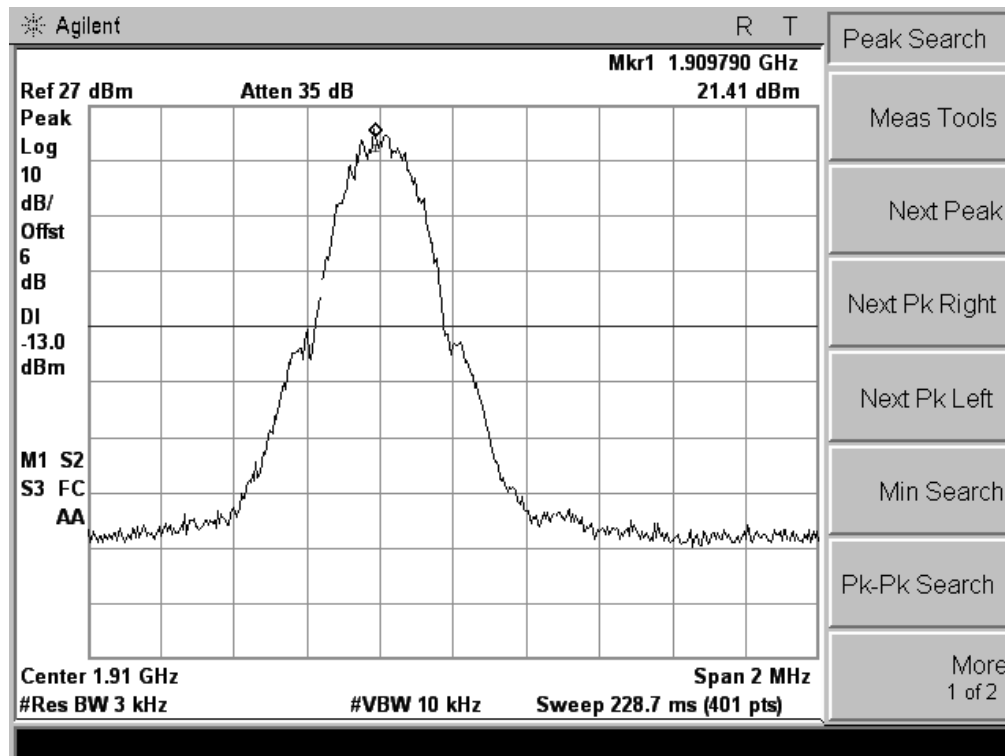

10. Transmitter Radiated Power (EIRP/ERP)

10.1 Requirement

According to FCC §24.232, the EIRP of Cellular mobile transmitters must not exceed 2 Watts (33dBm) e.i.r.p peak power.

10.2 Test Procedure

1. Perform test system setup as section 5.1.1.
2. The resolution bandwidth of the Spectrum Analyzer is set to be comparable to the emission bandwidth of the transmitter, e.g. for GSM modulated signal (here used): RBW=VBW=1MHz, for CDMA modulated signal: RBW=VBW=3MHz.
3. The low, middle and the high channels are selected to perform tests respectively. Set the TCH number to 512 as the low channel.
4. Employ the bi-log Test Antenna as the test system receiving antenna; set the polarization of the Test Antenna to be the same as that of the EUT transmitting antenna.
5. Set the frequency range of the Spectrum Analyzer suitably to capture the waveform; actuate the Turn Table to turn from 0 degrees to 360 degrees to find the maximum reading via the Spectrum Analyzer, mark the peak; finally record the peak and the plot.
6. Set the TCH number to 661 as the middle channel, then repeat step 5.
7. Set the TCH number to 810 as the high channel, then repeat step 5.

10.3 Test Result

| Band | Channel | Frequency (MHz) | Measured EIRP | | Limit EIRP | | Result |
|---------------------------|---------|-----------------|---------------|-------|------------|-----|--------|
| | | | dBm | W | dBm | W | |
| GSM1900 (GPRS class 8) | 512 | 1850.20 | 29.11 | 0.815 | < 33.0 | < 2 | PASS |
| | 661 | 1880.00 | 29.28 | 0.847 | < 33.0 | < 2 | PASS |
| | 810 | 1909.80 | 29.06 | 0.805 | < 33.0 | < 2 | PASS |

11. Radiated Spurious Emission

11.1 Requirement

According to FCC §24.238(a), the power of any emission outside of the authorized operating frequency ranges must be attenuated below the transmitting power (P) by a factor of at least $43+10*\log(P)$ dB. This calculated to be -13dBm.

11.2 Test Procedure

8. Perform test system setup as section 5.1.2.
9. Make a limit line whose value is -13dBm on the Spectrum Analyzer, and set the RBW of the Spectrum Analyzer to 1MHz.
10. The low, middle and the high channels are selected to perform tests respectively. Set the TCH number to 512 as the low channel.
11. Employ the bi-log Test Antenna as the test system receiving antenna and set the frequency range of the Spectrum Analyzer from 30MHz to 3GHz.
12. The measurement is performed with the Test Antenna at both horizontal and vertical polarization respectively. Set the polarization of the Test Antenna to be horizontal.
13. Actuate the Turn Table to turn from 0 degrees to 360 degrees to find the maximum reading via the Spectrum Analyzer, mark the fundamental frequency and the harmonics thereof, after then record the harmonics and the plot.
14. Set the polarization of the Test Antenna to be vertical, then repeat step 6.
15. Employ the horn Test Antenna as the test system receiving antenna and set the frequency range of the Spectrum Analyzer from 3GHz to 10th harmonic of the fundamental frequency (here used 10GHz), then repeat step 5 to 7.
16. Set the TCH number to 661 as the middle channel, then repeat step 4 to 8.
17. Set the TCH number to 810 as the high channel, then repeat step 4 to 8.

11.3 Test Result

| No. | Frequency (MHz) | Emission Power (dBm) | | Limit (dBm) |
|------------------------------------|-----------------|-----------------------|-------------------------|-------------|
| | | Test Antenna Vertical | Test Antenna Horizontal | |
| TCH number set to 512 (1850.20MHz) | | | | |
| 1 | 3700.40 | -41.09 | -42.65 | -13 |
| TCH number set to 661 (1880.0MHz) | | | | |
| 2 | 3760.00 | -41.52 | -41.84 | -13 |
| TCH number set to 810 (1909.80MHz) | | | | |
| 3 | 3819.60 | -42.06 | -42.78 | -13 |

12. Frequency Stability

12.1 Frequency Stability Requirement

According to FCC §24.235, the frequency stability shall be sufficient to ensure that the fundamental emission stays within the authorized frequency block.

According to FCC §2.1055, the test conditions are:

(a) Temperature:

The temperature is varied from -30°C to $+50^{\circ}\text{C}$ at intervals of not more than 10°C .

(b) Primary Supply Voltage:

For hand carried battery powered equipment, the primary supply voltage is reduced to the battery operating end point which shall be specified by the manufacture. The supply voltage shall be measured at the input to the cable normally provided with the equipment, or at the power supply terminals if cables are not normally provided.

12.2 Test Procedure

1. Perform test system setup as section 5.1.3.
2. Set the voltage of the DC Power Supply to normal supply voltage (here used 3.7V) and the temperature of the Temperature Chamber to vary from -30°C to $+50^{\circ}\text{C}$ at intervals of 10°C .
3. At each temperature level, the EUT is powered off and kept in the Temperature Chamber for two hours.
4. After sufficient stabilization, turn on the EUT, command it via the System Simulator (SS) to operate at the maximum output power i.e. Power Control Level (PCL) = 0 and Power Class = 1, and then establish a communication link between the EUT and the SS.
5. The low, middle and the high channels are selected to perform tests respectively. Set the TCH number to 512 as the low channel.
6. The frequency deviation is measured (directly read from the SS, which can report the parameter) within three minutes.
7. Set the TCH number to 661 as the middle channel, then repeat step 5.
8. Set the TCH number to 810 as the high channel, then repeat step 5.
9. Adjust the temperature of the Temperature Chamber as specified in step 2, then repeat step 3 to 7.
10. Set the voltage of the DC Power Supply to high extreme supply voltage (here used 4.2V) and the temperature of the Temperature Chamber to normal (here used $+22^{\circ}\text{C}$), then repeat step 3 to 8.
11. Set the voltage of the DC Power Supply to low extreme supply voltage (here used 3.6V) and the temperature of the Temperature Chamber to normal (here used $+22^{\circ}\text{C}$), then repeat step 3 to 8.

12.3 Test Result

| No. | Test Conditions | | Frequency Deviation (Hz) at Channels Used | | | |
|-----|-----------------|-------------|---|--------|--------|---|
| | Voltage | Temperature | 512 | 661 | 810 | Limit (±1ppm) |
| 1 | V-nor | -30°C | -48.11 | -49.42 | -48.54 | 2. ±1850Hz at 512 Channel 3. ±1880Hz at 661 Channel 4. ±1910Hz at 810 Channel |
| 2 | | -20°C | -43.63 | -44.16 | -42.86 | |
| 3 | | -10°C | -39.14 | -38.49 | -39.22 | |
| 4 | | 0°C | -32.64 | -31.52 | -32.53 | |
| 5 | | +10°C | -28.56 | -29.28 | -28.45 | |
| 6 | | +20°C | -34.16 | -32.69 | -33.62 | |
| 7 | | +30°C | -39.02 | -38.92 | -36.41 | |
| 8 | | +40°C | -44.38 | -43.68 | -42.28 | |
| 9 | | +50°C | -49.21 | -48.05 | -49.65 | |
| 10 | V-high | +22°C | -35.32 | -38.25 | -36.52 | |
| 11 | V-low | +22°C | -37.18 | -39.44 | -38.62 | |

Result: PASS

**APPENDIX 1
PHOTOGRAPHS OF EUT**

FRONT VIEW OF SAMPLE



BACK VIEW OF SAMPLE



LEFT VIEW OF SAMPLE



RIGHT VIEW OF SAMPLE



TOP VIEW OF SAMPLE



BOTTOM VIEW OF SAMPLE



PHOTO OF EARPHONE



PHOTO OF USB CABLE



PHOTO OF POWER SUPPLY



PHOTO OF BATTERY



INTERNAL PHOTO OF SAMPLE – 1



INTERNAL PHOTO OF SAMPLE – 2



INTERNAL PHOTO OF SAMPLE -3



INTERNAL PHOTO OF SAMPLE -4

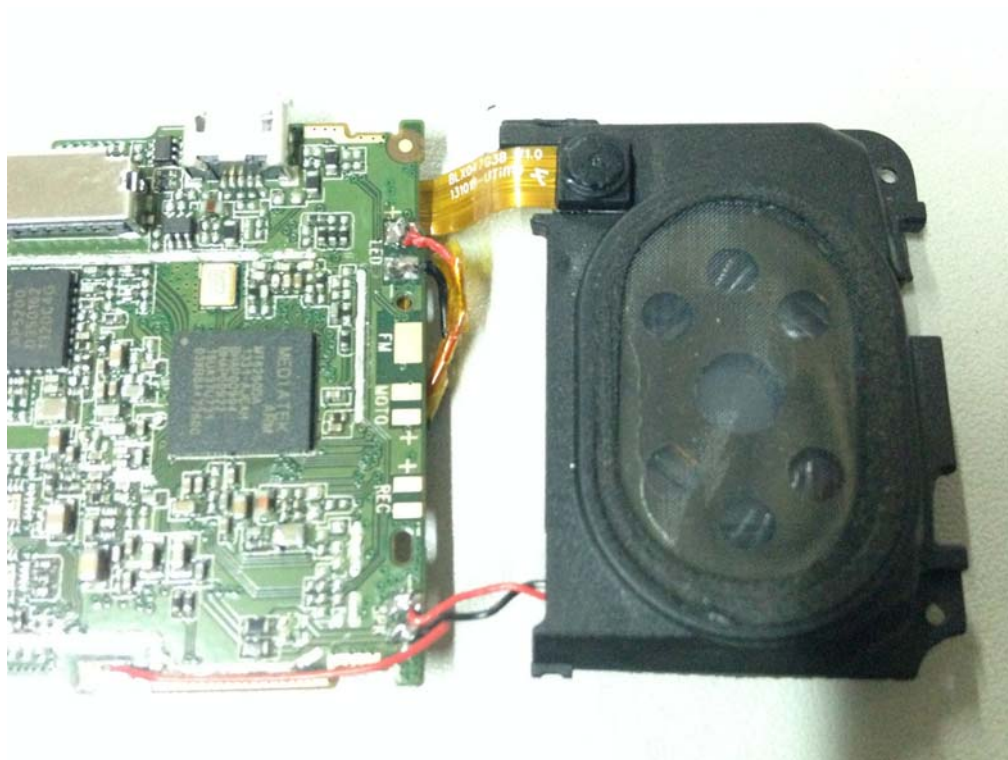

INTERNAL PHOTO OF SAMPLE -5



INTERNAL PHOTO OF SAMPLE -6



-----END OF REPORT-----