FCC Test Report

Report No.: AGC19U120201F1

FCC ID : SG71202HG-M306
PRODUCT DESIGNATION : Mobile Phone
BRAND NAME : Haier
MODEL NAME : HG-M306+
CLIENT : Haier Telecom (Qingdao) Co., Ltd.
DATE OF ISSUE : Feb. 27, 2012
STANDARD(S) : FCC Part 15 Rules

Attestation of **Global Compliance Co., Ltd.**

1. CAUTION: This report shall not be reproduced except in full without the written permission of the test laboratory and shall not be quoted out of context.

TABLE OF CONTENTS

1. VERIFICATION OF COMPLIANCE	2
2. PRODUCT INFORMATION	3
3. TEST FACILITY	4
4. SUPPORT EQUIPMENT LIST	5
5. SYSTEM DESCRIPTION	5
6 SUMMARY OF TEST RESULTS	6
7. FCC LINE CONDUCTED EMISSION TEST	7
7.1. TEST EQUIPMENT OF LINE CONDUCTED EMISSION TEST	7
7.2. LIMITS OF LINE CONDUCTED EMISSION TEST	7
7.3. BLOCK DIAGRAM OF LINE CONDUCTED EMISSION TEST	7
7.4. PROCEDURE OF LINE CONDUCTED EMISSION TEST	8
7.5 TEST RESULT OF LINE CONDUCTED EMISSION TEST	9
8. FCC RADIATED EMISSION TEST	11
8.1. TEST EQUIPMENT OF RADIATED EMISSION	11
8.2. LIMITS OF RADIATED EMISSION TEST	11
8.3 BLOCK DIAGRAM OF RADIATED EMISSION TEST	11
8.4 PROCEDURE OF RADIATED EMISSION TEST	11
8.4 PROCEDURE OF RADIATED EMISSION TEST	12
8.5 TEST RESULT OF RADIATED EMISSION TEST	13
APPENDIX 1	15
PHOTOGRAPHS OF TEST SETUP	15
APPENDIX 2	16
PHOTOGRAPHS OF EUT	16

1. VERIFICATION OF COMPLIANCE

Applicant:	Haier Telecom (Qingdao) Co., Ltd.
	No.1 Haier Road Hi-tech Zone Qingdao P.R.CHINA
Manufacturer:	Haier Telecom (Qingdao) Co., Ltd.
	No.1 Haier Road Hi-tech Zone Qingdao P.R.CHINA
Product Designation:	Mobile Phone
Brand name:	Haier
Model Name:	HG-M306+
FCC ID:	SG71202HG-M306
Measurement Procedure:	ANSI C63.4: 2003
File Number:	AGC19U120201F1
Date of test:	Feb.23, 2012 to Feb.24, 2012
Deviation:	None
Condition of Test Sample:	Normal

The above equipment was tested by Attestation Of Global Compliance Co., Ltd. for compliance with the requirements set forth in the FCC Rules and Regulations Part 15, the measurement procedure according to ANSI C63.4:2003. This said equipment in the configuration described in this report shows the maximum emission levels emanating from equipment are within the compliance requirements.

The test results of this report relate only to the tested sample identified in this report.

Tested By : 
Curoky Chen Feb. 27, 2012

Reviewed By : 
Forrest Lei Feb. 27, 2012

Approved By: 
Solger Zhang Feb. 27, 2012

2. PRODUCT INFORMATION

Frequency Band: GSM850 MHz :824.2 MHz – 848.8 MHz
PCS 1900 MHz :1850.2 MHz – 1909.8 MHz
It also supports GSM 900 / DCS 1800 non-US bands

Housing Type: Plastic

EUT Rating Voltage: DC 3.7V by battery

Adapter Input AC100~240V,50/60Hz,150mA

Adapter Output DC5.0V,550mA

I/O Port Information (Applicable Not Applicable)

I/O Port of EUT			
I/O Port Type	Q'TY	Cable	Tested with
USB port	1	1.0 m, unshielded	1
earphone	1	1.5m, unshielded	1

3. TEST FACILITY

Facility	Attestation of Global Compliance Co., Ltd.
Location:	1F, No.2 Building, Huafeng No.1 Technical, Industrial Park, Sanwei, Xixiang, Baoan District, Shenzhen, China
Description:	The test site is constructed and calibrated to meet the FCC requirements in documents ANSI C63.4:2003.
Site Filing:	The FCC Registration Number is 259865
Instrument Tolerance:	All measuring equipment is in accord with ANSI C63.4 requirements that meet industry regulatory agency and accreditation agency requirement.

4. SUPPORT EQUIPMENT LIST

Device Type	Manufacturer	Model Name	Serial No.	Data Cable	Power Cable
PC	DELL	Ins15RD-958	--	N/A	1.5m unshielded

**Note: All the above equipment/cables were placed in worse case positions to maximize emission signals during emission test.

5. SYSTEM DESCRIPTION

EUT test procedure:

1. Connect EUT and peripheral devices (PC) through USB port.
2. Power on the EUT, use the software to transfer data between EUT and PC.
3. Make sure the EUT operates normally during the test.

Test Mode

1. USB (connection for date transferring)
Other modes have been tested via the procedure of verification of confirm.

6 SUMMARY OF TEST RESULTS

FCC Rules	Description Of Test	Result
§15.107	Conduction Emission	Compliant
§15.109	Radiated Emission	Compliant

7. FCC LINE CONDUCTED EMISSION TEST

7.1. TEST EQUIPMENT OF LINE CONDUCTED EMISSION TEST

Description	Manufacturer	Model	Identifier	Cal. Date	Cal. Due
EMI Test Receiver	H.P.	8546A	N/A	06/27/2011	06/26/2012
LISN	EMCO	3825/2	N/A	06/27/2011	06/26/2012

7.2 .LIMITS OF LINE CONDUCTED EMISSION TEST

Frequency	Maximum RF Line Voltage	
	Q.P.(dBuV)	Average(dBuV)
150kHz~500kHz	66-56	56-46
500kHz~5MHz	56	46
5MHz~30MHz	60	50

**Note: 1. The lower limit shall apply at the transition frequency.

2. The limit decreases linearly with the logarithm of the frequency in the range 0.15 MHz to 0.50 MHz

7.3. BLOCK DIAGRAM OF LINE CONDUCTED EMISSION TEST

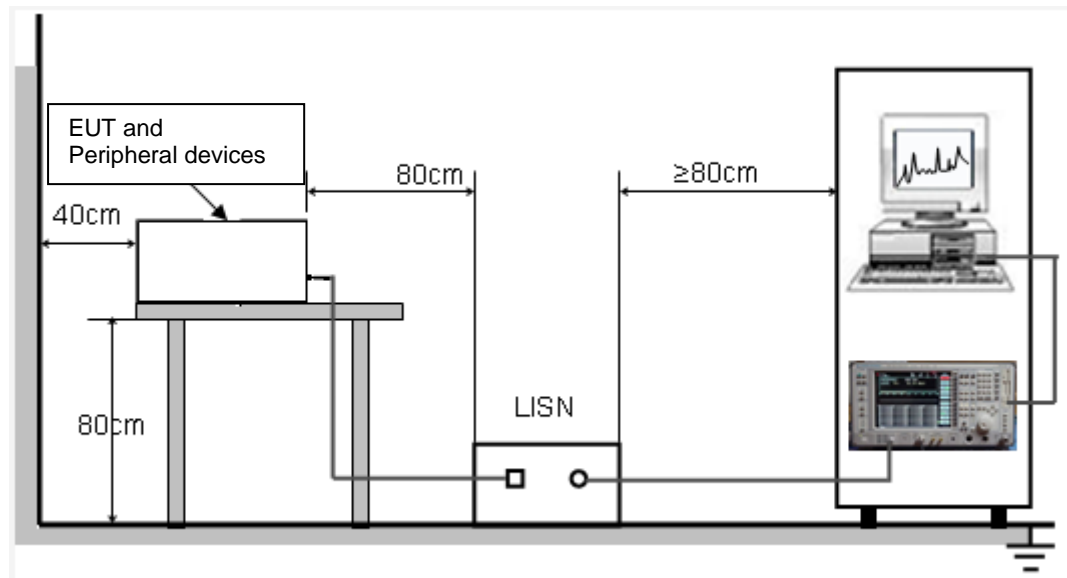

7.4. procedure of line conducted emission test

- 1) The equipment was set up as per the test configuration to simulate typical actual usage per the user's manual. When the EUT is a tabletop system, a wooden table with a height of 0.8 meters is used and is placed on the ground plane as per ANSI C63.4 (see Test Facility for the dimensions of the ground plane used). When the EUT is a floor-standing equipment, it is placed on the ground plane which has a 3-12 mm non-conductive covering to insulate the EUT from the ground plane.
- 2) Support equipment, if needed, was placed as per ANSI C63.4.
- 3) All I/O cables were positioned to simulate typical actual usage as per ANSI C63.4.
- 4) The EUT connect to PC which received 120V/60Hz power from a LISN.
- 5) The EUT test program was started. Emissions were measured on each current carrying line of the EUT using a spectrum Analyzer / Receiver connected to the LISN powering the EUT. The LISN has two monitoring points: Line 1 (Hot Side) and Line 2 (Neutral Side). Two scans were taken: one with Line 1 connected to Analyzer / Receiver and Line 2 connected to a 50 ohm load; the second scan had Line 1 connected to a 50 ohm load and Line 2 connected to the Analyzer / Receiver.
- 6) Analyzer / Receiver scanned from 150 kHz to 30MHz for emissions in each of the test modes.
- 7) During the above scans, the emissions were maximized by cable manipulation.
- 8) A scan was taken on both power lines, Line 1 and Line 2, recording at least the six highest emissions.
- 9) Emission frequency and amplitude were recorded into a computer in which correction factors were used to calculate the emission level and compare reading to the applicable limit. If EUT emission level was less -2dB to the A.V. limit in Peak mode, then the emission signal was re-checked using Q.P and Average detector.

The test data of the worst case condition(s) was reported on the Summary Data page.

7.5 TEST RESULT OF LINE CONDUCTED EMISSION TEST

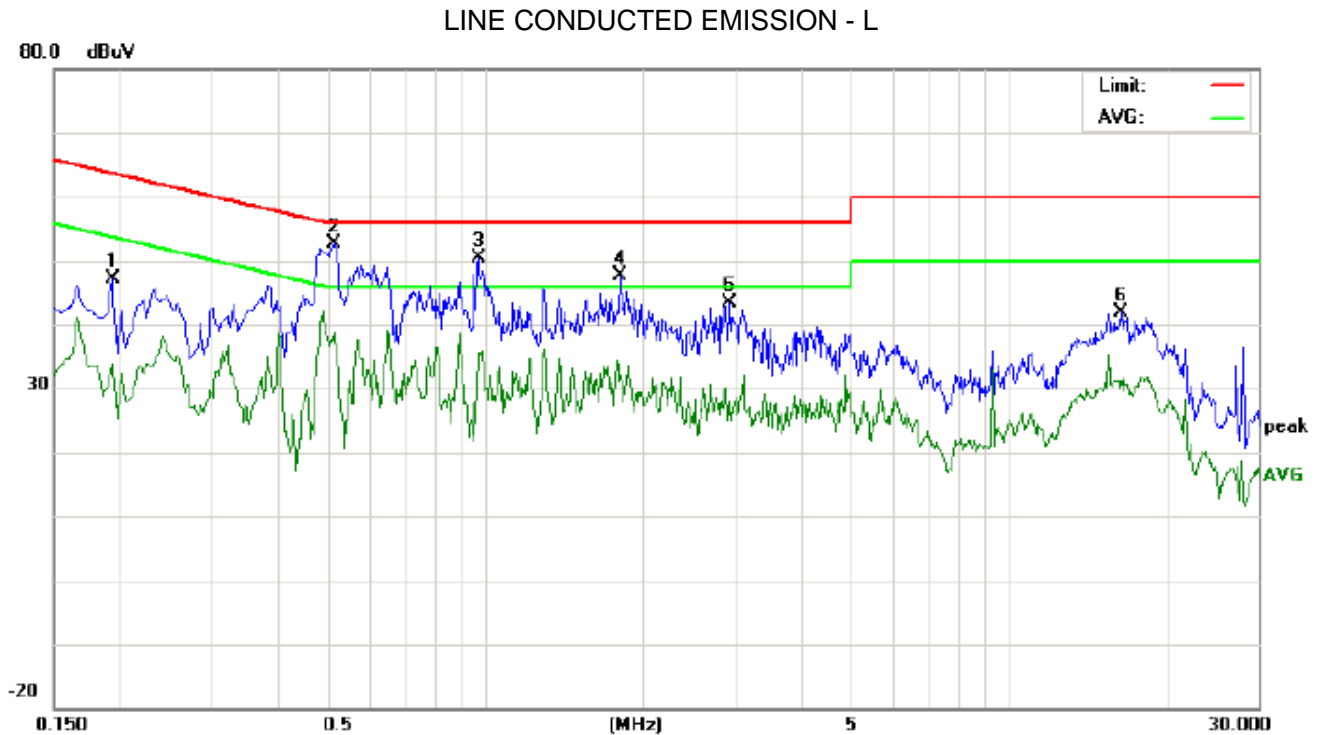

Site: Conduction	Phase: L1	Temperature: 26
Limit: FCC Class B Conduction(QP)	Power:	Humidity: 60 %
EUT: Mobile Phone		
M/N: HG-M306+		
Mode: USB		
Note:		

No.	Freq. (MHz)	Reading_Level (dBuV)			Correct Factor (dB)	Measurement (dBuV)			Limit (dBuV)		Margin (dB)		P/F	Comment
		Peak	QP	AVG		Peak	QP	AVG	QP	AVG	QP	AVG		
1	0.1940	36.99		23.63	10.21	47.20		33.84	63.86	53.86	-16.66	-20.02	P	
2	0.5140	42.12	39.95	26.37	10.39	52.51	50.34	36.76	56.00	46.00	-5.66	-9.24	P	
3	0.9700	39.89		23.26	10.38	50.27		33.64	56.00	46.00	-5.73	-12.36	P	
4	1.8140	37.24		21.95	10.28	47.52		32.23	56.00	46.00	-8.48	-13.77	P	
5	2.9420	32.94		17.52	10.54	43.48		28.06	56.00	46.00	-12.52	-17.94	P	
6	16.4820	31.79		20.73	10.12	41.91		30.85	60.00	50.00	-18.09	-19.15	P	

LINE CONDUCTED EMISSION – N

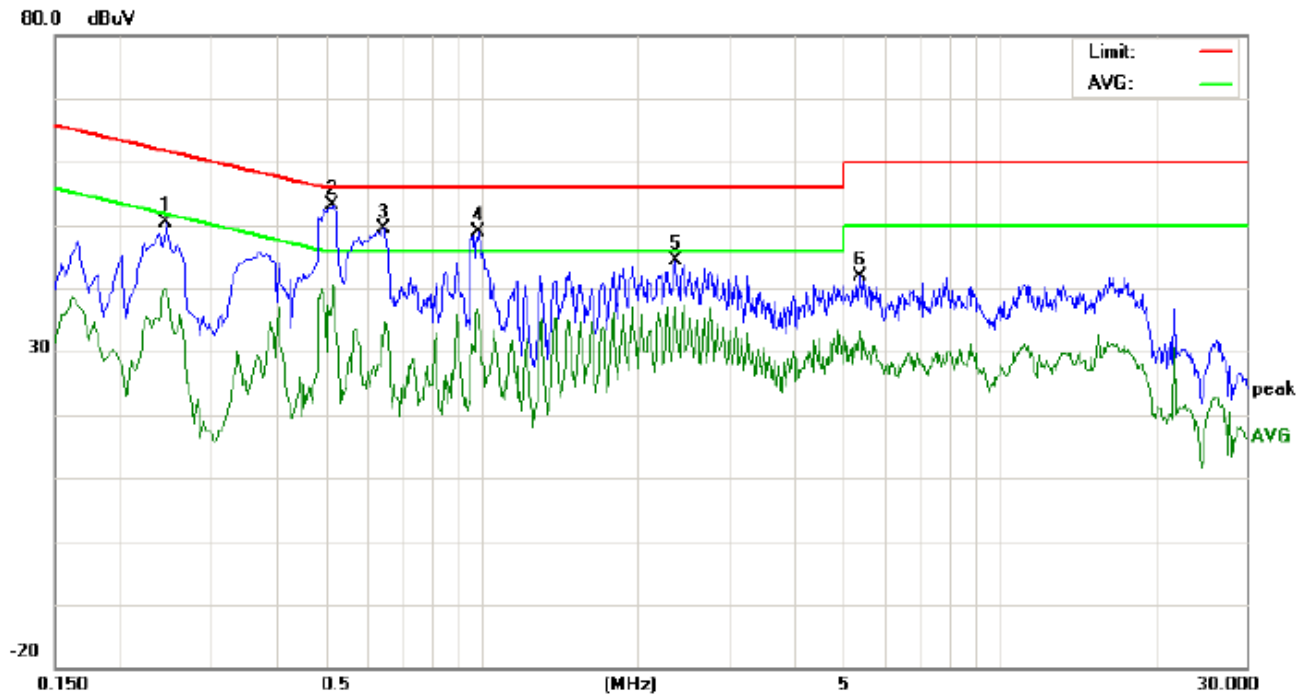

Site: Conduction Phase: **N** Temperature: 26
Limit: FCC Class B Conduction(QP) Power: Humidity: 60 %
EUT: Mobile Phone
M/N: HG-M306+
Mode: USB
Note:

No.	Freq. (MHz)	Reading_Level (dBuV)			Correct Factor (dB)	Measurement (dBuV)			Limit (dBuV)		Margin (dB)		P/F	Comment
		Peak	QP	AVG		Peak	QP	AVG	QP	AVG	QP	AVG		
1	0.2460	40.12		29.58	10.27	50.39		39.85	61.89	51.89	-11.50	-12.04	P	
2	0.5180	42.69	40.86	26.37	10.38	53.07	51.24	36.75	56.00	46.00	-4.76	-9.25	P	
3	0.6460	38.99		20.64	10.33	49.32		30.97	56.00	46.00	-6.68	-15.03	P	
4	0.9860	38.47		25.29	10.38	48.85		35.67	56.00	46.00	-7.15	-10.33	P	
5	2.3699	33.87		26.65	10.38	44.25		37.03	56.00	46.00	-11.75	-8.97	P	
6	5.3900	31.54		22.79	10.25	41.79		33.04	60.00	50.00	-18.21	-16.96	P	

8. FCC RADIATED EMISSION TEST

8.1. TEST EQUIPMENT OF RADIATED EMISSION

Description	Manufacturer	Model	Identifier	Cal. Date	Cal. Due
PSA SERIES SPECTRUM ANALYZER	AGILENT	E4440A	US41421290	06/27/2011	06/26/2012
ANTENNA	A.H.	SAS-521-4	128	06/27/2011	06/26/2012
HORN ANTENNA	EM	EM-AH-10180	N/A	06/27/2011	06/26/2012
AMPLIFIER	EM	EM30180	0607030	06/27/2011	06/26/2012
POSITIONING CONTROLLER	MF	MF-7802	MF780208147	06/27/2011	06/26/2012

8.2. LIMITS OF RADIATED EMISSION TEST

Frequency (MHz)	Distance (m)	Maximum Field Strength Limit (dBuV/m/ Q.P.)
30~88	3	40.0
88~216	3	43.5
216~960	3	46.0
Above 960	3	54.0

**Note: The lower limit shall apply at the transition frequency.

8.3 BLOCK DIAGRAM OF RADIATED EMISSION TEST

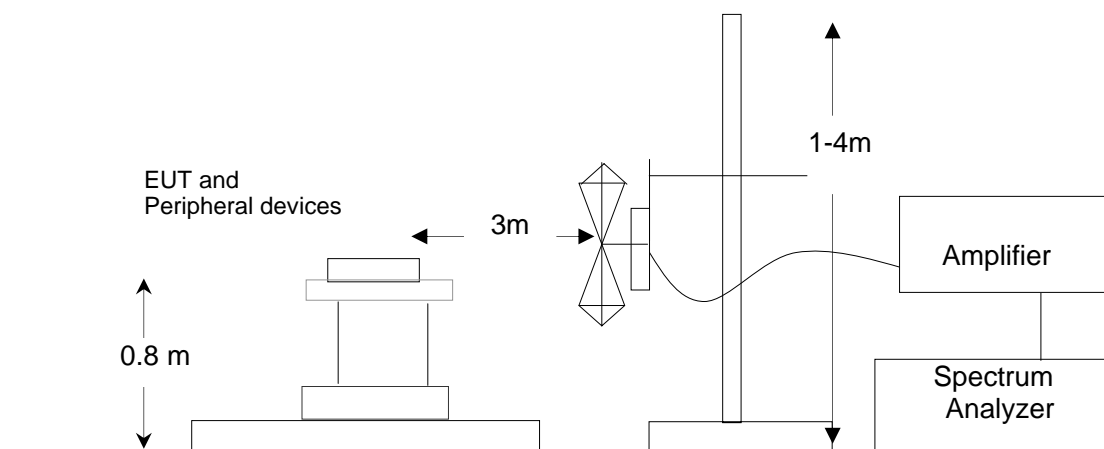

8.4 PROCEDURE OF RADIATED EMISSION TEST

- 1) The equipment was set up as per the test configuration to simulate typical actual usage per the user's manual. When the EUT is a tabletop system, a wooden turntable with a height of 0.8 meters is used which is placed on the ground plane as per ANSI C63.4 (see Test Facility for the dimensions of the ground plane used). When the EUT is floor-standing equipment, it is placed on the ground plane which has a 3-12 mm non-conductive covering to insulate the EUT from the ground plane.
- 2) Support equipment, if needed, was placed as per ANSI C63.4.
- 3) All I/O cables were positioned to simulate typical actual usage as per ANSI C63.4.
- 4) The EUT connect to PC which received 120V/60Hz power from socket under the turntable.
- 5) The antenna was placed at 3 meter away from the EUT as stated in FCC Part 15. The antenna connected to the Analyzer via a cable and at times a pre-amplifier would be used.
- 6) The Analyzer / Receiver quickly scanned from 30MHz to 1000MHz. The EUT test program was started. Emissions were scanned and measured rotating the EUT to 360 degrees and positioning the antenna 1 to 4 meters above the ground plane, in both the vertical and the horizontal polarization, to maximize the emission reading level.
- 7) The test mode(s) were scanned during the test.
- 8) Recorded at least the six highest emissions. Emission frequency, amplitude, antenna position, polarization and turntable position were recorded into a computer in which correction factors were used to calculate the emission level and compare reading to the applicable limit and Q.P./Peak reading is presented.

8.5 TEST RESULT OF RADIATED EMISSION TEST

Radiated Emission Test –Horizontal -3m

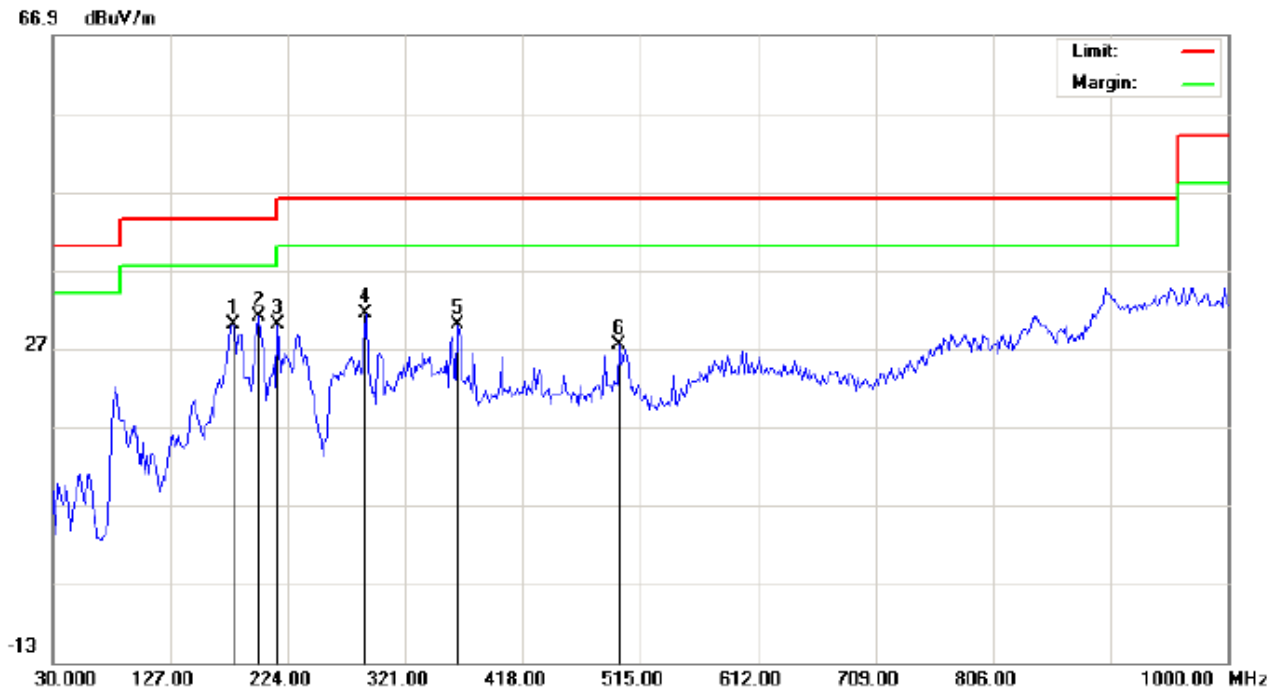

Site: site #1
Limit: FCC Class B 3M Radiation
EUT: Mobile Phone
M/N: HG-M306+
Mode: USB
Note:

Polarization: *Horizontal*
Power: AC 120V/60Hz
Distance: 3m

Temperature: 26
Humidity: 60 %

No.	Mk	Freq.	Reading	Factor	Measurement	Limit	Over	Detector	Antenna Height	Table Degree	Comment
		MHz	dBuV	dB/m	dBuV/m	dBuV/m	dB		cm	degree	
1		178.7333	12.12	17.91	30.03	43.50	-13.47	peak			
2	*	199.7500	18.86	12.23	31.09	43.50	-12.41	peak			
3		215.9166	17.09	12.93	30.02	43.50	-13.48	peak			
4		288.6666	14.21	17.11	31.32	46.00	-14.68	peak			
5		364.6499	10.95	19.14	30.09	46.00	-15.91	peak			
6		497.2167	4.66	22.78	27.44	46.00	-18.56	peak			

Radiated Emission Test –Vertical -3m

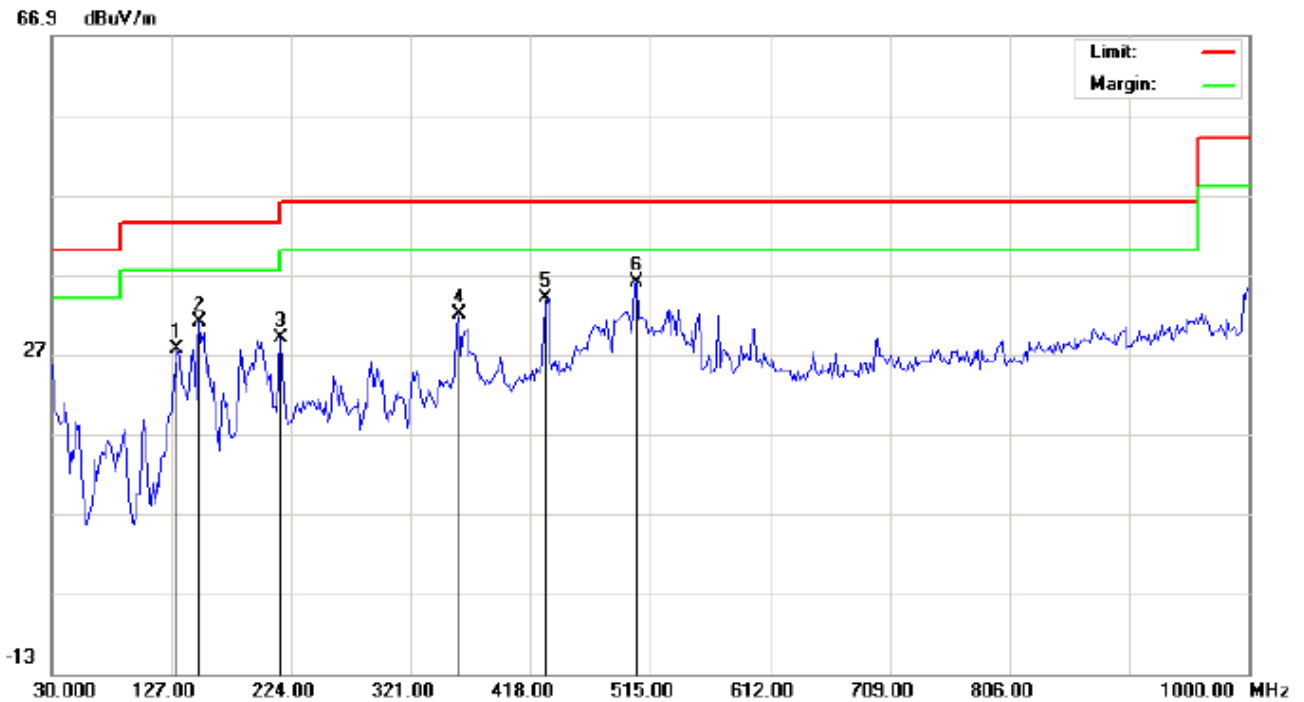

Site: site #1
Limit: FCC Class B 3M Radiation
EUT: Mobile Phone
M/N: HG-M306+
Mode: USB
Note:

Polarization: **Vertical**
Power: AC 120V/60Hz
Distance: 3m

Temperature: 26
Humidity: 60 %

No.	Mk	Freq.	Reading	Factor	Measurement	Limit	Over	Detector	Antenna Height	Table Degree	Comment
		MHz	dBuV	dB/m	dBuV/m	dBuV/m	dB		cm	degree	
1		131.8499	11.70	15.82	27.52	43.50	-15.98	peak			
2		149.6332	11.97	19.00	30.97	43.50	-12.53	peak			
3		215.9166	14.54	14.56	29.10	43.50	-14.40	peak			
4		359.8000	12.94	19.11	32.05	46.00	-13.95	peak			
5		430.9332	12.45	21.46	33.91	46.00	-12.09	peak			
6	*	503.6832	12.90	23.02	35.92	46.00	-10.08	peak			

APPENDIX 1 PHOTOGRAPHS OF TEST SETUP

FCC LINE CONDUCTED EMISSION TEST SETUP



FCC RADIATED EMISSION TEST SETUP

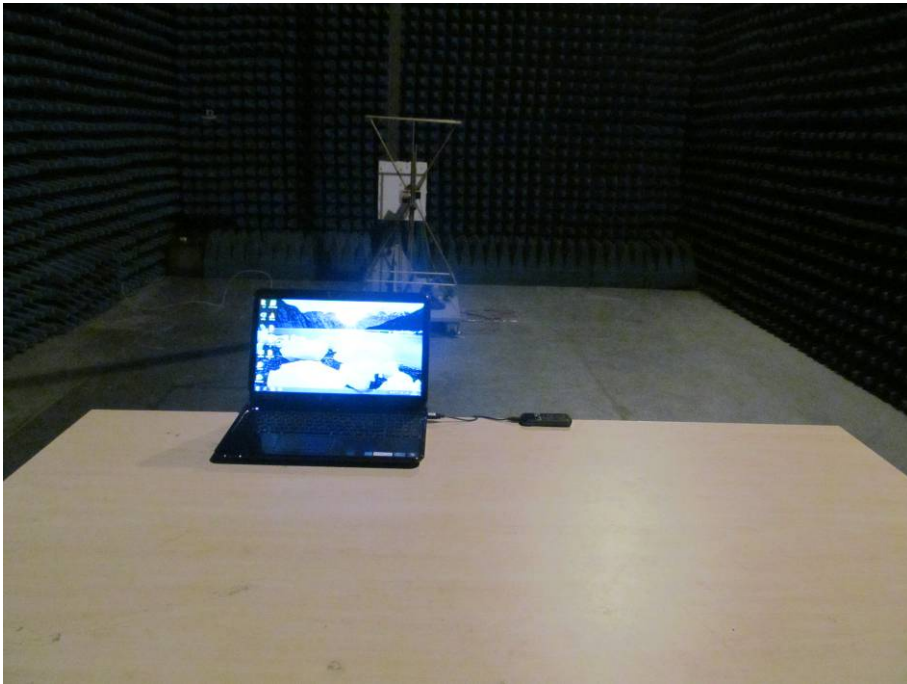

APPENDIX 2 PHOTOGRAPHS OF EUT

TOP VIEW OF SAMPLE



BOTTOM VIEW OF SAMPLE



LEFT VIEW OF SAMPLE



RIGHT VIEW OF SAMPLE



FRONT VIEW OF SAMPLE



BACK VEIW OF SAMPLE



ALL VIEW OF SAMPLE



OPEN VIEW OF SAMPLE-1



OPEN VIEW OF SAMPLE-2

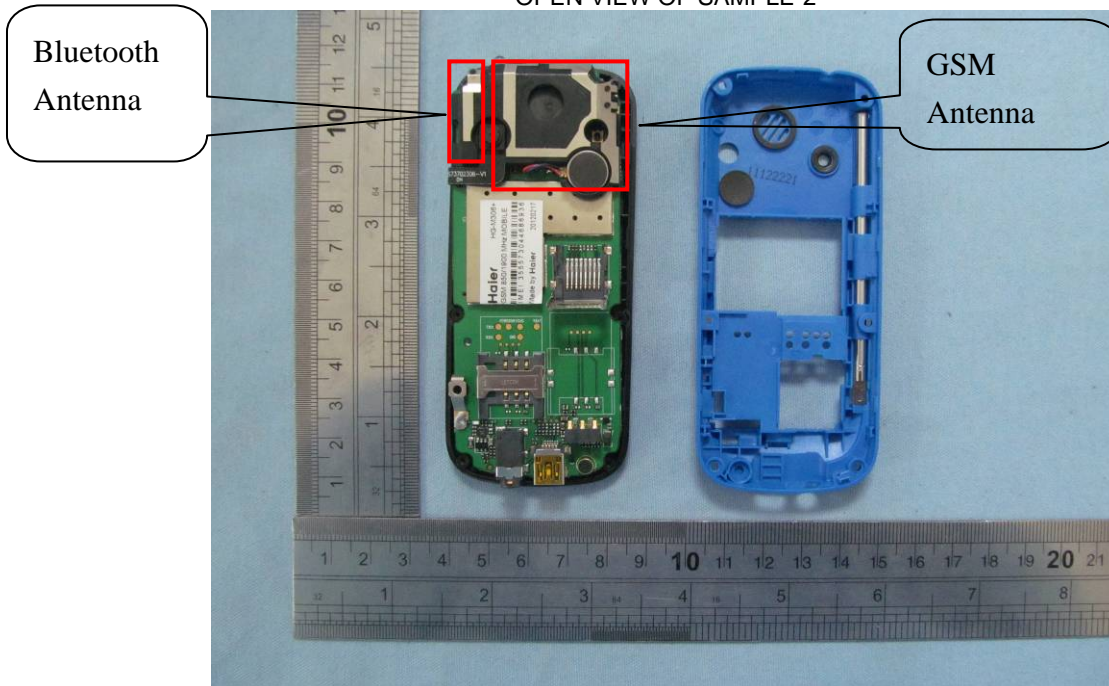

OPEN VIEW OF SAMPLE-3



INTERNAL VIEW OF SAMPLE – 1

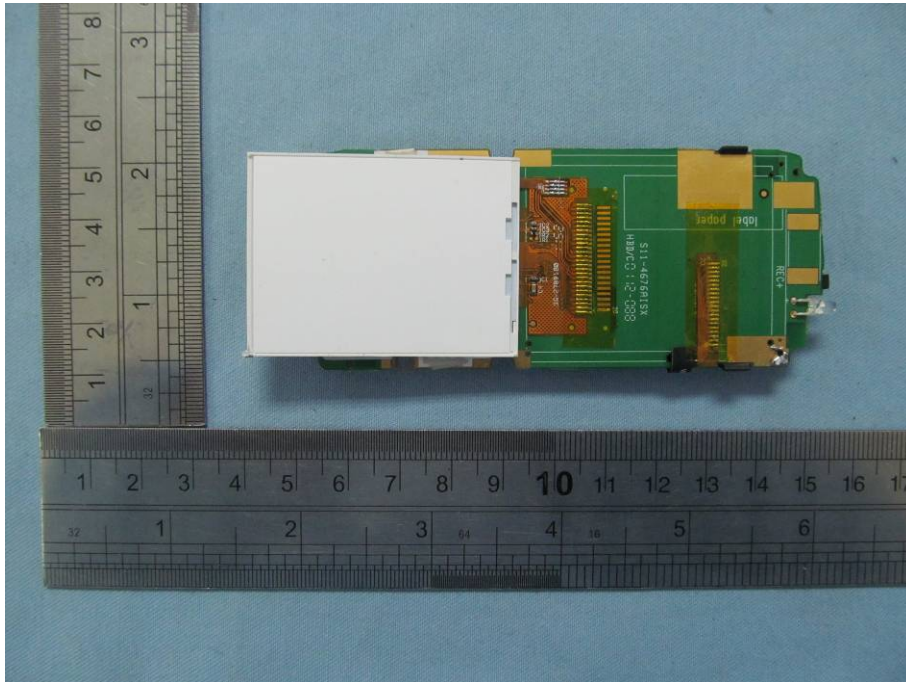

INTERNAL VIEW OF SAMPLE – 2

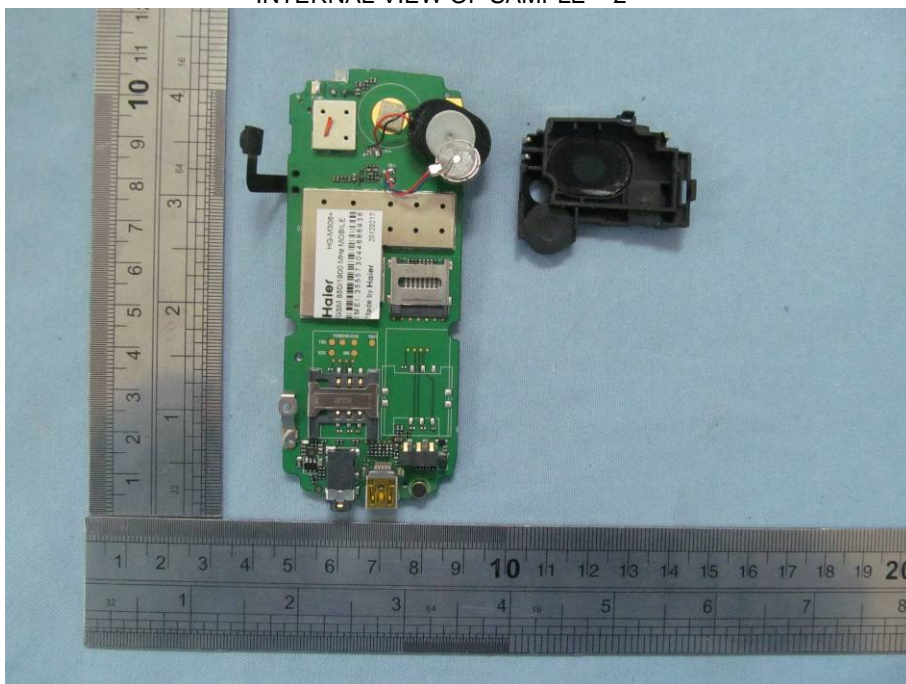

INTERNAL VIEW OF SAMPLE – 3

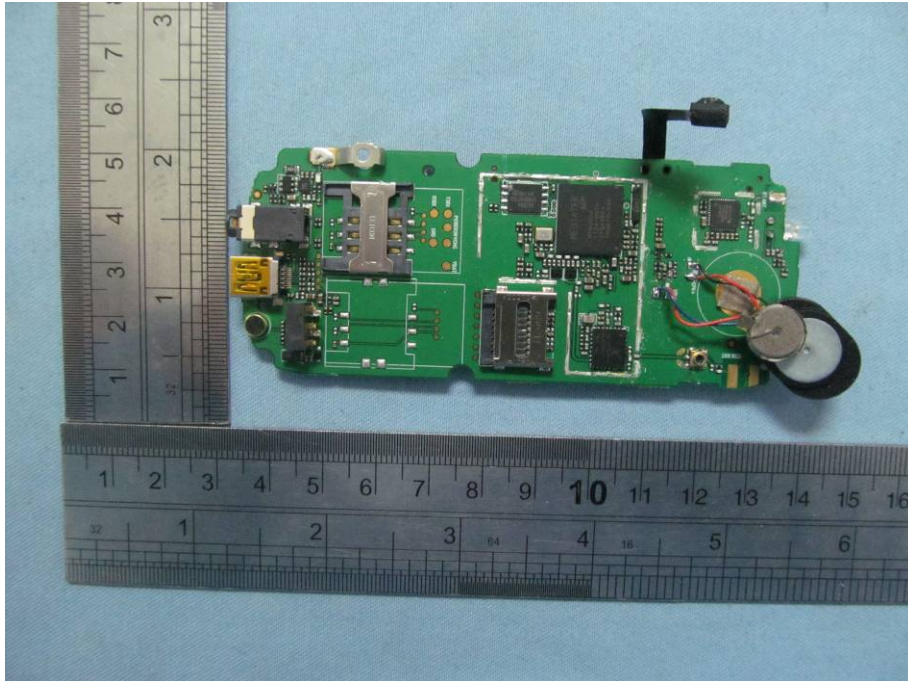

----END OF REPORT----