

FCC Test Report

APPLICANT : QingDao Haier Telecom Co., Ltd.
EQUIPMENT : MOBILE PHONE
BRAND NAME : Haier
MODEL NAME : HW-A56W
FCC ID : SG71104HW-A56W
STANDARD : FCC 47 CFR FCC Part 15 Subpart B
CLASSIFICATION : Certification

The product was received on Apr. 19, 2011 and completely tested on May 20, 2011. We, SPORTON INTERNATIONAL (KUNSAHN) INC., would like to declare that the tested sample has been evaluated in accordance with the procedures given in ANSI C63.4-2003 and shown the compliance with the applicable technical standards.

The test results in this report apply exclusively to the tested model / sample. Without written approval of SPORTON INTERNATIONAL (KUNSHAN) INC., the test report shall not be reproduced except in full.

Reviewed by:



Jones Tsai / Manager



SPORTON INTERNATIONAL (KUNSHAN) INC.
No. 3-2, PingXiang Road, Kunshan, Jiangsu Province, P.R.C.



TABLE OF CONTENTS

REVISION HISTORY	3
SUMMARY OF TEST RESULT	4
1. GENERAL DESCRIPTION.....	5
1.1. Applicant	5
1.2. Manufacturer.....	5
1.3. Feature of Equipment Under Test	5
1.4. Test Site.....	6
1.5. Applied Standards.....	6
1.6. Ancillary Equipment List	6
2. TEST CONFIGURATION OF EQUIPMENT UNDER TEST	7
2.1. Test Mode	7
2.2. Connection Diagram of Test System	9
2.3. Test Software.....	10
3. TEST RESULT	11
3.1. Test of AC Conducted Emission Measurement.....	11
3.2. Test of Radiated Emission Measurement.....	15
4. LIST OF MEASURING EQUIPMENT	19
5. UNCERTAINTY OF EVALUATION	20
APPENDIX A. PHOTOGRAPHS OF EUT	
APPENDIX B. SETUP PHOTOGRAPHS	



SUMMARY OF TEST RESULT

Report Section	FCC Rule	IC Rule	Description	Limit	Result	Remark
3.1	15.107	7.2.2	AC Conducted Emission	< 15.107 limits < RSS-Gen table 2 limits	PASS	Under limit 13.80 dB at 1.59 MHz
3.2	15.109	7.2.3.2	Radiated Emission	< 15.109 limits or < RSS-Gen table 1 limits (Section 6)	PASS	Under limit 7.61 dB at 45.76 MHz



1. General Description

1.1. Applicant

QingDao Haier Telecom Co., Ltd.

No. 1, Haier Road Hi-tech Zone Qingdao, 266101 P.R.China

1.2. Manufacturer

Haier Telecom (Qingdao) Co., Ltd.

No. 1, Haier Road Hi-tech Zone Qingdao, 266101 P.R.China

1.3. Feature of Equipment Under Test

Product Feature & Specification	
Equipment	MOBILE PHONE
Brand Name	Haier
Model Name	HW-A56W
FCC ID	SG71104HW-A56W
Tx Frequency Range	GSM850 : 824 MHz ~ 849 MHz GSM1900 : 1850 MHz ~ 1910 MHz WCDMA Band V : 824 MHz ~ 849 MHz WCDMA Band II : 1850 MHz ~ 1910 MHz Bluetooth : 2400 MHz ~ 2483.5 MHz
Rx Frequency Range	GSM850 : 869 MHz ~ 894 MHz GSM1900 : 1930 MHz ~ 1990 MHz WCDMA Band V : 869 MHz ~ 894 MHz WCDMA Band II : 1930 MHz ~ 1990 MHz Bluetooth : 2400 MHz ~ 2483.5 MHz
Antenna Type	WWAN : Fixed Internal Antenna Bluetooth : Chip Antenna
HW Version	M232
SW Version	LQW6301.1.0_M232
Type of Modulation	GSM / GPRS : GMSK EDGE : 8PSK WCDMA : QPSK Bluetooth (1Mbps) : GFSK Bluetooth EDR (2Mbps) : $\pi/4$ -DQPSK Bluetooth EDR (3Mbps) : 8-DPSK
EUT Stage	Production Unit

Remark: The above EUT's information was declared by manufacturer. Please refer to the specifications or user's manual for more detailed description.



1.4. Test Site

Test Site	SPORTON INTERNATIONAL (KUNSHAN) INC.	
Test Site Location	No. 3-2, PingXiang Road, Kunshan, Jiangsu Province, P.R.C. TEL: +86-0512-5790-0158 FAX: +86-0512-5790-0958	
Test Site No.	Sporton Site No.	
	CO01-KS	03CH01-KS

1.5. Applied Standards

According to the specifications of the manufacturer, the EUT must comply with the requirements of the following standards:

- FCC 47 CFR FCC Part 15 Subpart B
- ANSI C63.4-2003
- IC RSS-Gen Issue 3

Remark:

- 1, All test items were verified and recorded according to the standards and without any deviation during the test.
- 2, This report is intention of applying for FCC 15B certification only.

1.6. Ancillary Equipment List

Item	Equipment	Trade Name	Model Name	FCC ID	Data Cable	Power Cord
1.	System Simulator	R&S	CMU 200	N/A	N/A	Unshielded, 1.8 m
2.	Signal Generator	R&S	SMR40	N/A	N/A	Unshielded, 1.8 m
3.	Bluetooth Earphone	Nokia	BH-102	PYAHS-107W	N/A	N/A
4.	PC	DELL	MT320	FCC DoC	N/A	Unshielded, 1.8 m
5.	iPod	Apple	A1199	FCC DoC	Shielded, 1.2 m	N/A
6.	(USB) Mouse	DELL	MO56UC	FCC DoC	Shielded, 1.8 m	N/A
7.	(USB) Keyboard	DELL	L100	FCC DoC	Shielded, 1.8 m with Core	N/A
8.	Printer	HP	Laser Jet 1018	FCC DoC	Unshielded, 1.8 m	Unshielded, 1.8 m
9.	Monitor	DELL	E1910Hc	FCC DoC	Shielded, 1.2 m	Unshielded, 1.8 m

2. Test Configuration of Equipment Under Test

2.1. Test Mode

The EUT has been associated with peripherals pursuant to ANSI C63.4-2003 and configuration operated in a manner tended to maximize its emission characteristics in a typical application.

Frequency range investigated: conduction (150 kHz to 30 MHz), radiation (30MHz to the 5th harmonic of the highest fundamental frequency or to 40 GHz, whichever is lower).

The following tables are showing the test modes as the worst cases and recorded in this report.

Item	EUT Configuration	Test Condition		
		EMI AC	EMI RE<1G	EMI RE≥1G
1.	Charging Mode (EUT with adapter)	<input checked="" type="checkbox"/>	<input checked="" type="checkbox"/>	<input checked="" type="checkbox"/>
2.	Charging Mode (EUT with PC)	<input checked="" type="checkbox"/>	<input checked="" type="checkbox"/>	Note 1

Abbreviations:

- I EMI AC: AC conducted emissions
- I EMI RE ≥ 1G: EUT radiated emissions ≥ 1GHz
- I EMI RE < 1G: EUT radiated emissions < 1GHz

Note 1: Testing for this mode is not required or not the worst case.



Test Items	EUT Configure Mode	Function Type
AC Conducted Emission	1/2	Mode 1: GSM850 Idle + Bluetooth Idle + Adapter + Camera + Earphone Mode 2: GSM900 Idle + Bluetooth Idle + Adapter + MP3 + Earphone Mode 3: WCDMA Band V Idle + Bluetooth Idle + Adapter + FM Rx + Earphone Mode 4: WCDMA Band II Idle + Bluetooth Idle + Earphone + USB Cable (Charging from PC)
Radiated Emissions < 1GHz	1/2	Mode 1: GSM850 Idle + Bluetooth Idle + Adapter + Camera + Earphone Mode 2: GSM900 Idle + Bluetooth Idle + Adapter + MP3 + Earphone Mode 3: WCDMA Band V Idle + Bluetooth Idle + Adapter + FM Rx + Earphone Mode 4: WCDMA Band II Idle + Bluetooth Idle + Earphone + USB Cable (Charging from PC)
Radiated Emissions ≥ 1GHz	1	Mode 1: GSM850 Idle + Bluetooth Idle + Adapter + Camera + Earphone
Remark: <ol style="list-style-type: none">1. The worst case of AC is mode 4; only the test data of this mode was reported.2. The worst case of RE < 1G is mode 1; only the test data of this mode was reported.		

2.2. Connection Diagram of Test System

<EUT with Adapter Mode>

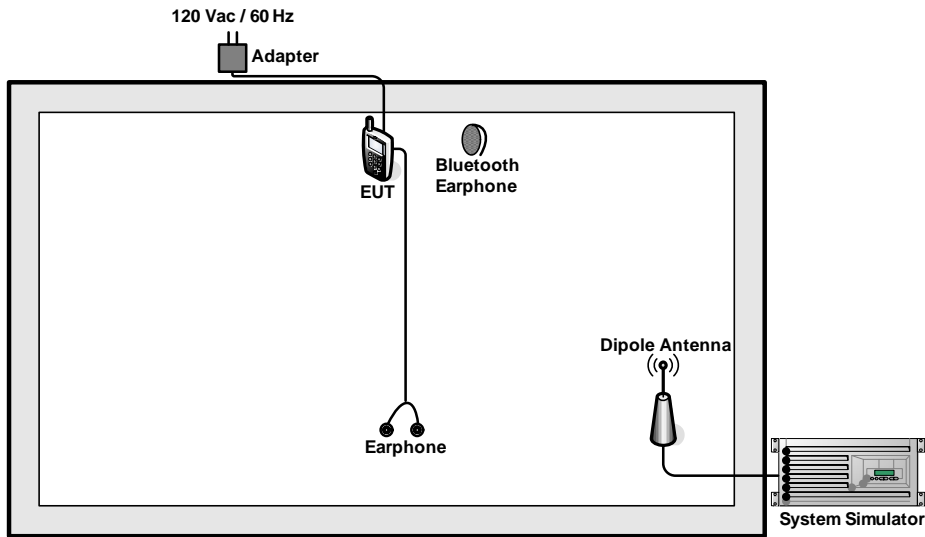

<EUT with Adapter in FM Rx Mode>

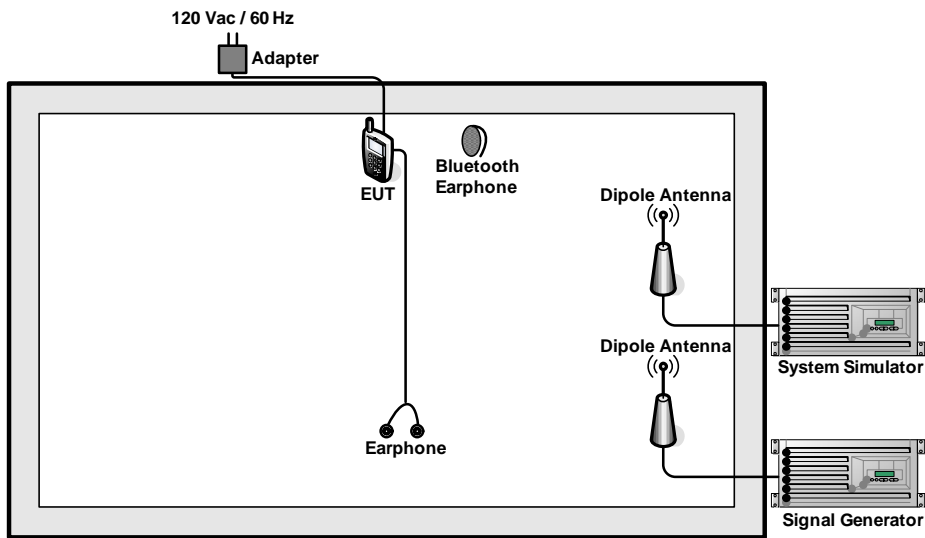

<EUT with USB Cable (Link with PC) Mode>

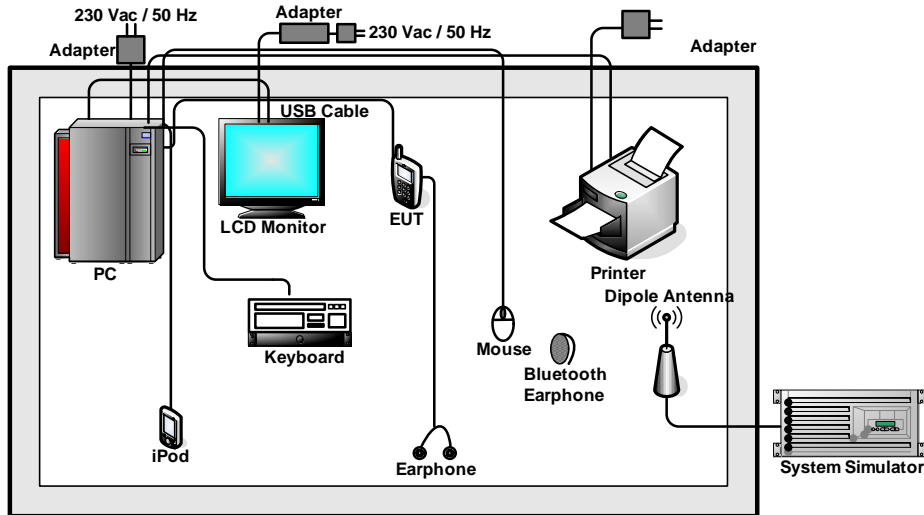

2.3. Test Software

The EUT was in GSM or WCDMA idle mode during the testing. The EUT was synchronized to the BCCH, and is in continuous receiving mode by setting system simulator's paging reorganization.

At the same time, the EUT was attached to the Bluetooth earphone, and the following programs installed in the EUT were programmed during the test.

1. Execute the program, "Winthrax", installed in PC for active sync files transfer with EUT via USB cable / iPod.
2. Execute "Music Player" to play MP3 file.
3. Turn on camera to capture images.
4. Keep the EUT receiving signals continuously in FM Rx mode.

3. Test Result

3.1. Test of AC Conducted Emission Measurement

3.1.1 Limits of AC Conducted Emission

For equipment that is designed to be connected to the public utility (AC) power line, the radio frequency voltage that is conducted back onto the AC power line on any frequency or frequencies within the band 150 kHz to 30 MHz shall not exceed the limits in the following table.

Frequency of emission (MHz)	Conducted limit (dBuV)	
	Quasi-peak	Average
0.15-0.5	66 to 56*	56 to 46*
0.5-5	56	46
5-30	60	50

*Decreases with the logarithm of the frequency.

3.1.2 Measuring Instruments

See list of measuring instruments of this test report.

3.1.3 Test Procedure

1. The EUT was placed 0.4 meter from the conducting wall of the shielding room was kept at least 80 centimeters from any other grounded conducting surface.
2. Connect EUT to the power mains through a line impedance stabilization network (LISN).
3. All the support units are connecting to the other LISN.
4. The LISN provides 50 ohm coupling impedance for the measuring instrument.
5. The FCC states that a 50 ohm, 50 microhenry LISN should be used.
6. Both sides of AC line were checked for maximum conducted interference.
7. The frequency range from 150 kHz to 30 MHz was searched.
8. Set the test-receiver system to Peak Detect Function and specified bandwidth with Maximum Hold Mode.

3.1.4 Test Setup

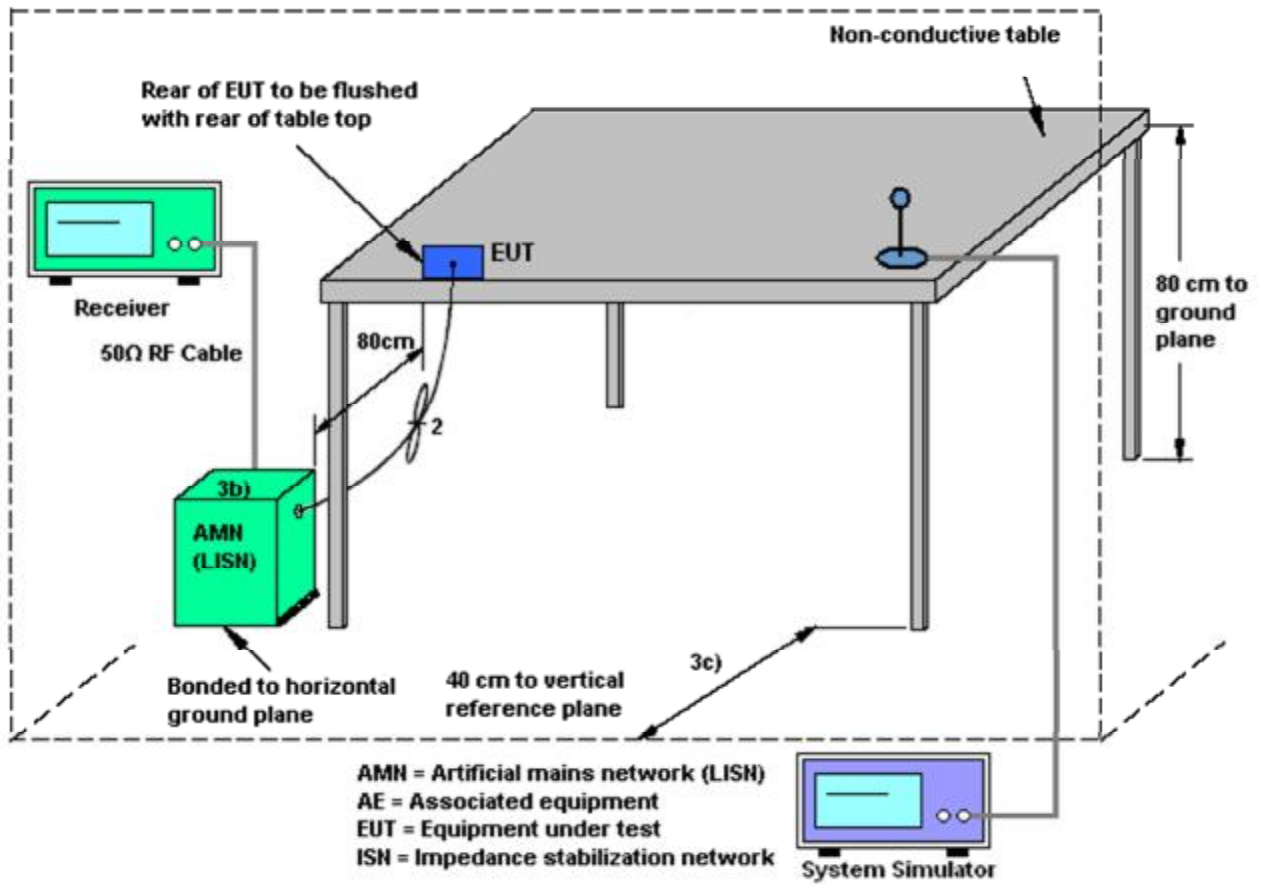



3.1.5 Test Result of AC Conducted Emission

Test Mode :	Mode 4	Temperature :	20~21°C
Test Engineer :	Chenmy Cheng	Relative Humidity :	40~41%
Test Voltage :	120Vac / 60Hz	Phase :	Line
Function Type :	WCDMA Band II Idle + Bluetooth Idle + Earphone + USB Cable (Charging from PC)		
Remark :	All emissions not reported here are more than 10 dB below the prescribed limit.		

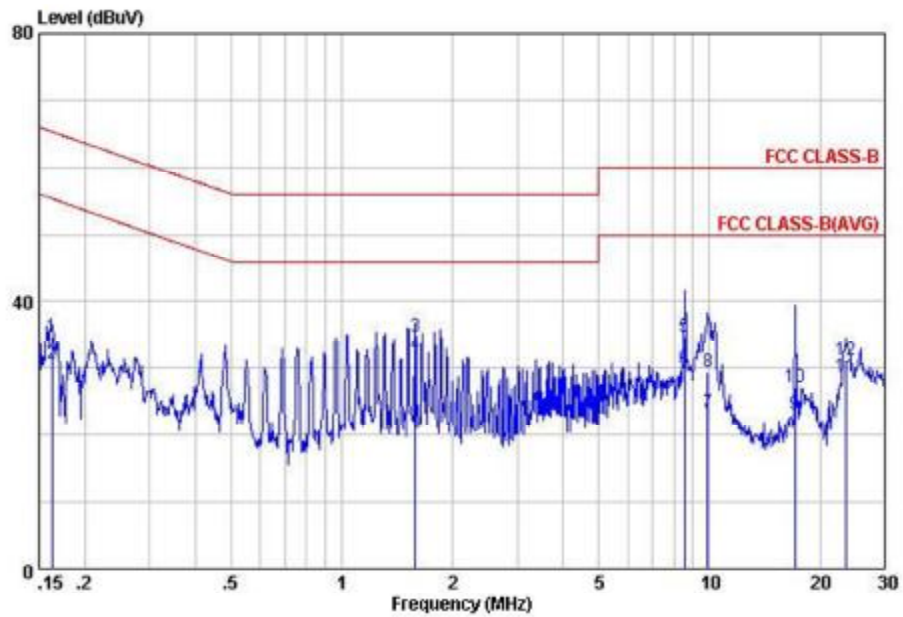

Site : C001-KS
Condition: FCC CLASS-B LISN-100807 LINE

mode : Mode 4

	Freq	Level	Over	Limit	Read	LISN	Cable	Remark
	MHz	dBuV	Limit	Line	Level	Factor	Loss	
			dB	dBuV	dBuV	dB	dB	
1	0.16	34.67	-30.67	65.34	24.60	-0.07	10.14	QP
2	0.16	30.67	-24.67	55.34	20.60	-0.07	10.14	Average
3	1.59	34.80	-21.20	56.00	24.60	-0.11	10.31	QP
4	1.59	32.20	-13.80	46.00	22.00	-0.11	10.31	Average
5	8.55	34.82	-25.18	60.00	24.50	-0.12	10.44	QP
6	8.55	29.82	-20.18	50.00	19.50	-0.12	10.44	Average
7	9.91	23.45	-26.55	50.00	13.10	-0.11	10.46	Average
8	9.91	29.45	-30.55	60.00	19.10	-0.11	10.46	QP
9	17.11	23.16	-26.84	50.00	12.61	0.02	10.53	Average
10	17.11	27.16	-32.84	60.00	16.61	0.02	10.53	QP
11	23.64	28.66	-21.34	50.00	17.89	0.14	10.63	Average
12	23.64	31.26	-28.74	60.00	20.49	0.14	10.63	QP



Test Mode :	Mode 4	Temperature :	20~21°C
Test Engineer :	Chenmy Cheng	Relative Humidity :	40~41%
Test Voltage :	120Vac / 60Hz	Phase :	Neutral
Function Type :	WCDMA Band II Idle + Bluetooth Idle + Earphone + USB Cable (Charging from PC)		
Remark :	All emissions not reported here are more than 10 dB below the prescribed limit.		

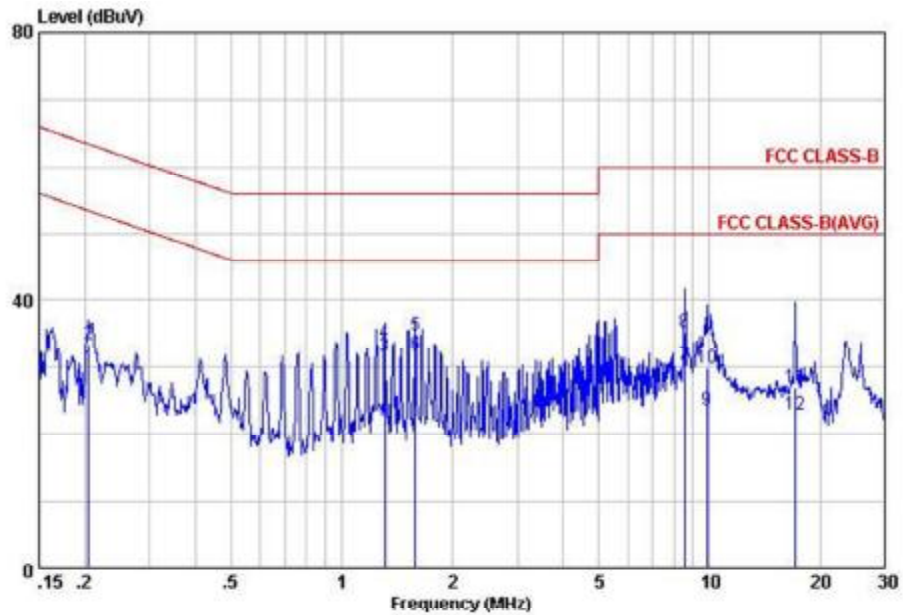

Site : C001-KS
 Condition: FCC CLASS-B LISN-100807 NEUTRAL

mode : Mode 4

	Freq	Level	Over	Limit	Read	LISN	Cable	Remark
	MHz	dBuV	Limit	Line	Level	Factor	Loss	
			dB	dBuV	dBuV	dB	dB	
1	0.21	29.88	-23.52	53.40	19.80	-0.07	10.15	Average
2	0.21	33.38	-30.02	63.40	23.30	-0.07	10.15	QP
3	1.31	31.69	-14.31	46.00	21.50	-0.10	10.29	Average
4	1.31	33.59	-22.41	56.00	23.40	-0.10	10.29	QP
5	1.59	34.70	-21.30	56.00	24.49	-0.10	10.31	QP
6	1.59	31.80	-14.20	46.00	21.59	-0.10	10.31	Average
7	8.55	30.21	-19.79	50.00	19.90	-0.13	10.44	Average
8	8.55	35.21	-24.79	60.00	24.90	-0.13	10.44	QP
9	9.86	23.72	-26.28	50.00	13.40	-0.13	10.45	Average
10	9.86	29.82	-30.18	60.00	19.50	-0.13	10.45	QP
11	17.11	27.04	-32.96	60.00	16.50	0.01	10.53	QP
12	17.11	23.04	-26.96	50.00	12.50	0.01	10.53	Average



3.2. Test of Radiated Emission Measurement

3.2.1. Limit of Radiated Emission

The emissions from an intentional radiator shall not exceed the field strength levels specified in the following table:

Frequency (MHz)	Field Strength (microvolts/meter)	Measurement Distance (meters)
0.009 – 0.490	2400/F(kHz)	300
0.490 – 1.705	24000/F(kHz)	30
1.705 – 30.0	30	30
30 – 88	100	3
88 – 216	150	3
216 - 960	200	3
Above 960	500	3

3.2.2. Measuring Instruments

See list of measuring instruments of this test report.

3.2.3. Test Procedures

1. The EUT was placed on a turntable with 0.8 meter above ground.
2. The EUT was set 3 meters from the interference receiving antenna, which was mounted on the top of a variable height antenna tower.
3. The table was rotated 360 degrees to determine the position of the highest radiation.
4. The antenna is a Bi-Log antenna and its height is adjusted between one meter and four meters above ground to find the maximum value of the field strength for both horizontal polarization and vertical polarization of the antenna.
5. For each suspected emission, the EUT was arranged to its worst case and then tune the antenna tower (from 1 m to 4 m) and turntable (from 0 degree to 360 degrees) to find the maximum reading.
6. Set the test-receiver system to Peak Detect Function and specified bandwidth with Maximum Hold Mode.
7. If the emission level of the EUT in peak mode was 3 dB lower than the limit specified, then testing will be stopped and peak values of EUT will be reported, otherwise, the emissions will be repeated one by one using the quasi-peak method and reported
8. Emission level (dBuV/m) = 20 log Emission level (uV/m)
9. Corrected Reading: Antenna Factor + Cable Loss + Read Level - Preamp Factor = Level

3.2.4. Test Setup of Radiated Emission

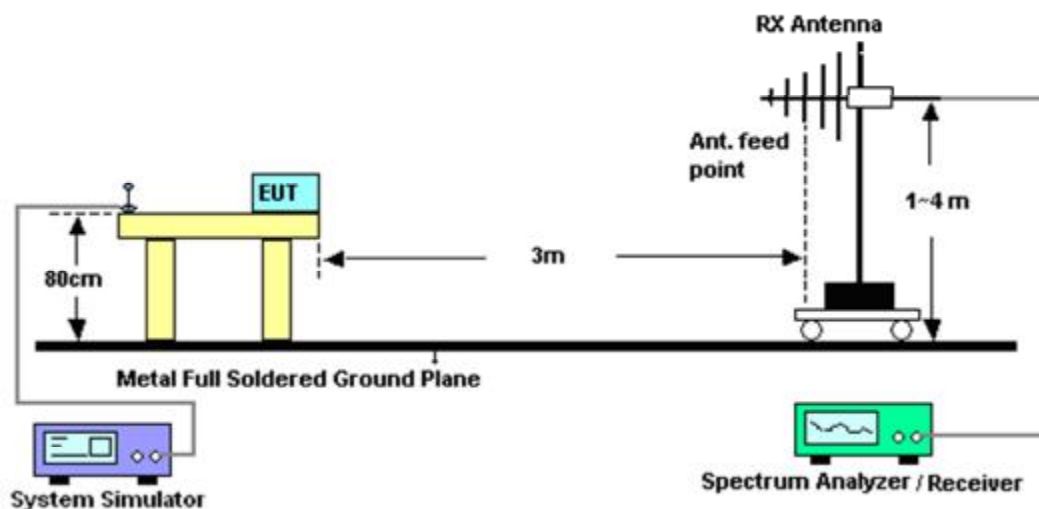



3.2.5. Test Result of Radiated Emission

Test Mode :	Mode 1	Temperature :	20~21°C
Test Engineer :	Jason Jia	Relative Humidity :	40~41%
Test Distance :	3m	Polarization :	Horizontal
Function Type :	GSM850 Idle + Bluetooth Idle + Adapter + Camera + Earphone		

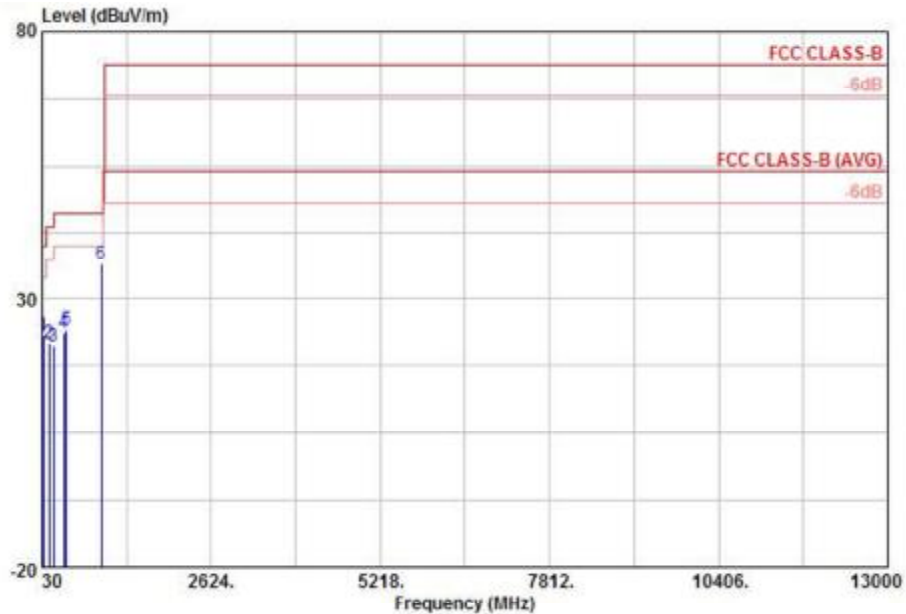

Site : 03CH01-KS
 Condition: FCC CLASS-B 3m LF_ANT_100803 HORIZONTAL

Mode : mode 1

	Freq	Level	Over	Limit	ReadAntenna	Cable	Preamp	Ant	Table	Remark	
	MHz	dBuV/m	dB	dBuV/m	dBuV	dB/m	dB	dB	cn	deg	
1	46.20	23.21	-16.79	40.00	44.19	8.88	0.27	30.13	---	---	Peak
2	144.21	21.84	-21.66	43.50	40.88	10.45	0.50	29.99	---	---	Peak
3	211.17	21.31	-22.19	43.50	41.16	9.54	0.60	29.99	---	---	Peak
4	364.40	23.78	-22.22	46.00	38.01	14.86	0.82	29.91	---	---	Peak
5	402.90	24.21	-21.79	46.00	37.19	16.01	0.84	29.83	---	---	Peak
6	941.90	36.46	-9.54	46.00	43.96	20.70	1.33	29.53	100	0	Peak



Test Mode :	Mode 1	Temperature :	20~21°C
Test Engineer :	Jason Jia	Relative Humidity :	40~41%
Test Distance :	3m	Polarization :	Vertical
Function Type :	GSM850 Idle + Bluetooth Idle + Adapter + Camera + Earphone		

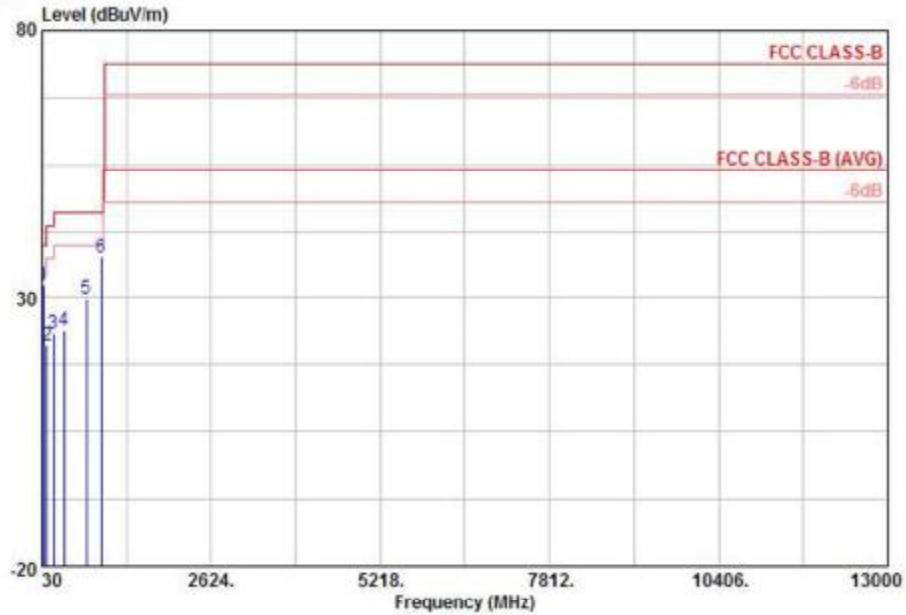

Site : 03CH01-KS
 Condition: FCC CLASS-B 3m LF_ANT_100803 VERTICAL

Mode : mode 1

	Freq	Level	Over	Limit	ReadAntenna	Cable	Preamp	Ant	Table	Remark
	MHz	dBuV/m	dB	dBuV/m	dBuV	Loss	Factor	Pos	Pos	
					dB/n	dB	dB	cn	deg	
1	45.76	32.39	-7.61	40.00	53.00	9.25	0.27	30.13	100	85 QP
2	102.36	21.19	-22.31	43.50	39.86	10.87	0.42	29.96	---	Peak
3	211.17	23.38	-20.12	43.50	43.23	9.54	0.60	29.99	---	Peak
4	364.40	24.12	-21.88	46.00	38.35	14.86	0.82	29.91	---	Peak
5	710.20	30.00	-16.00	46.00	39.17	19.39	1.14	29.70	---	Peak
6	941.90	37.59	-8.41	46.00	45.09	20.70	1.33	29.53	---	Peak



4. List of Measuring Equipment

Instrument	Manufacturer	Model No.	Serial No.	Characteristics	Calibration Date	Due Date	Remark
EMI Receiver	R&S	ESCI7	100768	9kHz~7GHz	Jun. 22, 2010	Jun. 21, 2011	Conduction (CO01-KS)
LISN	MessTec	AN3016	60103	9kHz~30MHz	Jan. 07, 2011	Jan. 06, 2012	Conduction (CO01-KS)
LISN	MessTec	AN3016	60105	9kHz~30MHz	Jan. 07, 2011	Jan. 06, 2012	Conduction (CO01-KS)
AC Power Source	Chroma	61602	ABP00000081 1	N/A	Nov. 10, 2010	Nov. 09, 2011	Conduction (CO01-KS)
System Simulator	R&S	CMU200	837587/066	Full-Band	Jan. 07, 2011	Jan. 06, 2012	Conduction (CO01-KS)
GPS Station	T&E	GS-50	N/A	N/A	N/A	N/A	Conduction (CO01-KS)
EMI Test Receiver	R&S	ESCI	100534	9kHz~3GHz	Nov. 16, 2010	Nov. 15, 2011	Radiation (03CH01-KS)
Spectrum Analyzer	R&S	FSP40	100319	9kHz~40GHz	Jan. 07, 2010	Jan. 06, 2012	Radiation (03CH01-KS)
Bilog Antenna	SCHAFFNER	CBL6112D	23182	25MHz~2GHz	Dec. 07, 2010	Dec. 06, 2011	Radiation (03CH01-KS)
Double Ridge Horn Antenna	EMCO	3117	00075959	1MHz~18GHz	Jan. 07, 2010	Jan. 06, 2012	Radiation (03CH01-KS)
Amplifier	Wireless	FPA-6592G	060004	30MHz~2GHz	Dec. 09, 2010	Dec. 08, 2011	Radiation (03CH01-KS)
Amplifier	Agilent	8449B	3008A02370	1GHz~26.5GHz	Jan. 07, 2010	Jan. 06, 2012	Radiation (03CH01-KS)
Active horn antenna	com-power	AHA-118	701023	1G-18GHz	Nov. 09, 2010	Nov. 08, 2011	Radiation (03CH01-KS)
Signal Generator	R&S	SMR40	100455	10G-40GHz	Jan. 06, 2010	Jan. 05, 2012	Radiation (03CH01-KS)
SHE-EHF Horn	Schwarzbeck	BBHA9170	BBHA170249	15-40GHz	Oct. 15, 2010	Oct. 14, 2011	Radiation (03CH01-KS)
Loop Antenna	R&S	HFH2-Z2	860004/00	9G-30GHz	Jul. 29, 2010	Jul. 28, 2011	Radiation (03CH01-KS)
Bluetooth Base Station	R&S	CBT	100783	N/A	Aug. 17, 2010	Aug. 16, 2011	Radiation (03CH01-KS)

5. Uncertainty of Evaluation

Uncertainty of Conducted Emission Measurement (150 kHz ~ 30 MHz)

Contribution	Uncertainty of X_i		$u(X_i)$
	dB	Probability Distribution	
Receiver Reading	0.10	Normal (k=2)	0.05
Cable Loss	0.10	Normal (k=2)	0.05
AMN Insertion Loss	2.50	Rectangular	0.63
Receiver Specification	1.50	Rectangular	0.43
Site Imperfection	1.39	Rectangular	0.80
Mismatch	+0.34 / -0.35	U-Shape	0.24
Combined Standard Uncertainty $U_c(y)$	1.13		
Measuring Uncertainty for a Level of Confidence of 95% ($U = 2U_c(y)$)	2.26		

Uncertainty of Radiated Emission Measurement (30 MHz ~ 1000 MHz)

Contribution	Uncertainty of X_i		$u(X_i)$
	dB	Probability Distribution	
Receiver Reading	0.41	Normal (k=2)	0.21
Antenna Factor Calibration	0.83	Normal (k=2)	0.42
Cable Loss Calibration	0.25	Normal (k=2)	0.13
Pre-Amplifier Gain Calibration	0.27	Normal (k=2)	0.14
RCV/SPA Specification	2.50	Rectangular	0.72
Antenna Factor Interpolation for Frequency	1.00	Rectangular	0.29
Site Imperfection	1.43	Rectangular	0.83
Mismatch	+0.39 / -0.41	U-Shape	0.28
Combined Standard Uncertainty $U_c(y)$	1.27		
Measuring Uncertainty for a Level of Confidence of 95% ($U = 2U_c(y)$)	2.54		



Uncertainty of Radiated Emission Measurement (1 GHz ~ 40 GHz)

Contribution	Uncertainty of X_i		$u(X_i)$	C_i	$C_i * u(X_i)$
	dB	Probability Distribution			
Receiver Reading	±0.10	Normal (k=2)	0.10	1	0.10
Antenna Factor Calibration	±1.70	Normal (k=2)	0.85	1	0.85
Cable Loss Calibration	±0.50	Normal (k=2)	0.25	1	0.25
Receiver Correction	±2.00	Rectangular	1.15	1	1.15
Antenna Factor Directional	±1.50	Rectangular	0.87	1	0.87
Site Imperfection	±2.80	Triangular	1.14	1	1.14
Mismatch Receiver VSWR $\Gamma_1 = 0.197$ Antenna VSWR $\Gamma_2 = 0.194$ Uncertainty = $20\text{Log}(1-\Gamma_1*\Gamma_2)$	+0.34 / -0.35	U-Shape	0.244	1	0.244
Combined Standard Uncertainty $Uc(y)$	2.36				
Measuring Uncertainty for a Level of Confidence of 95% ($U = 2Uc(y)$)	4.72				