



47 CFR PART 22H& 24E

TEST REPORT

of

CDMA1X EV-DO Modem

Trade Name: Haier
Brand Name: Haier
Model Name: CE100
Report No.: SZ09030174E02
FCC ID.: SG70904CE100

prepared for

Qingdao Haier Telecom Co.Ltd.

No.1, HaierRoad, Hi-tech Zone, Qingdao, 266101, P.R.China



Shenzhen Electronic Product Quality Testing Center

Morlab Laboratory

3/F, Electronic Testing Building, Shahe Road, Xili,
Nanshan District, Shenzhen, 518055 P. R. China

Tel: +86 755 86130398

Fax: +86 755 86130218



Bluetooth® **CTIA** Authorized Test Lab

LAB CODE 20081223-00

NOTE: This test report can be duplicated completely for the legal use with the approval of the applicant; it shall not be reproduced except in full, without the written approval of Shenzhen Electronic Product Quality Testing Center Morlab Laboratory. Any objections should be raised to us within thirty workdays since the date of issue.

TABLE OF CONTENTS

2.1	Equipment under Test (EUT) Description.....	5
2.2	Test Standards and Results.....	6
2.3	Facilities and Accreditations	7
2.3.1	Facilities	7
2.3.2	Test Equipments	7
2.3.3	Test Environment Conditions	8
3.1	General Information	9
3.1.1	Conducted Related Tests	9
3.1.2	Radiated Power and Spurious Emission Tests.....	10
3.1.3	Frequency Stability Test	11
3.2	Frequencies	12
3.2.1	Requirement	12
3.2.2	Test Procedure	12
3.2.3	Test Result	13
3.3	Conducted RF Output Power.....	15
3.3.1	Requirement	15
3.3.2	Test Procedure	15
3.3.3	Test Result	15
3.4	Occupied Bandwidth.....	17
3.4.1	Occupied Bandwidth Definition.....	17
3.4.2	Test Procedure	17
3.4.3	Test Result	17
3.5	Conducted Spurious Emission	21
3.5.1	Requirement	21
3.5.2	Test Procedure	21
3.5.3	Test Result	21
3.6	Band Edge	25
3.6.1	Requirement	25
3.6.2	Test Result	25
3.7	Transmitter Radiated Power (EIRP/ERP).....	28
3.7.1	Requirement	28



3.7.2	Test Procedure	28
3.7.3	Test Result	28
3.8	Radiated Spurious Emission	30
3.8.1	Requirement	30
3.8.2	Test Procedure	30
3.8.3	Test Result	30
3.9	Frequency Stability	38
3.9.1	Requirement	38
3.9.2	Test Description	38
3.9.3	Test Procedure	38
3.9.4	Test Result	39

1. Test Result Certification

Equipment under Test: CDMA1X EV-DO Modem

Brand Name: Haier
Model Name: CE100
FCC ID: SG70904CE100

Applicant: Qingdao Haier Telecom Co.Ltd.
No.1, HaierRoad, Hi-tech Zone, Qingdao, 266101, P.R.China
Manufacturer: Haier
No.1, HaierRoad, Hi-tech Zone, Qingdao, 266101, P.R.China

Test Standards: 47 CFR Part 2
47 CFR Part 22 Subpart H
47 CFR Part 24 Subpart E

Test Result: PASS

* We Hereby Certify That:

The equipment under test was tested by Shenzhen Morlab Communications Technology Co., Ltd. The test data, data evaluation, test procedures and equipment configurations shown in this report were made in accordance with the requirement of related FCC rules.

The test results of this report only apply for the tested sample equipment identified above. The test report shall be invalid without all the signatures of the test engineer, the reviewer and the approver.

Tested by: Li Yi Dated: 2009.04.22
Li Yi

Reviewed by: Ni Yong Dated: 2009.04.22
Ni Yong

Approved by: Wei Yanquan Dated: 2009.04.22
Wei Yanquan



2. General Information

2.1 Equipment under Test (EUT) Description

Description	CDMA1X EV-DO Modem
Model Name	CE100
Serial No.....	N/A
MEID	N/A
Hardware Version	SP
Software Version.....	HACE100MT01
Emission Designator.....	1M25F9W
Modulation	CDMA 1X
Frequency	Tx: 824.7 – 848.31 MHz; Rx: 869.7-893.31MHz Tx: 1851.25 MHz -1908.75 MHz; Rx: 1931.25 MHz-1988.75 MHz

NOTE:

1. The EUT is a model of CDMA 1X800/1900MHz Wireless Data Terminal supported EVDO . When testing, the EUT was power by a USB point, and a connecting between EUT and base station was established at the start of the test, and maintained during the all test in this report.
2. The EUT can receive the electric power from the PC via USB point and can be used as a storage when inserted with a T-Flash card.
3. The transmitter (Tx) frequency arrangement of the CDMA 1900MHz band used by the EUT can be represented with the formula $F(n)=1851.2+0.05*(n-25)$, $25 \leq n \leq 1175$; the lowest, middle and highest channel numbers (ARFCHs) used and tested in this report are separately 25 (1851.2MHz), 600 (1880.0MHz) and 1175 (1908.7MHz).
4. For detailed features about the EUT, please see user manual supplied by the applicant.



2.2 Test Standards and Results

The objective of the report is to perform tests according to 47 CFR Part 2, Part 15 Part 22 for FCC ID Certification:

No.	Identity	Document Title
1	47 CFR Part 2 (10-1-05 Edition)	Frequency Allocations and Radio Treaty Matters; General Rules and Regulations
2	47 CFR Part 22 (10-1-05 Edition)	Public Mobile Services
3	47 CFR Part 24 (10-1-05 Edition)	Personal Communications Services

Test detailed items and the results are as below:

No.	Rules	Test Type	Result	Date of Test
FCC Part 22 Requirement				
1	§2.106, §22.905	Frequencies	PASS	2009-4-8
2	§2.1046	Conducted RF Output Power at Antenna Terminal	PASS	2009-4-8
3	§2.1049	Occupied Bandwidth	PASS	2009-4-8
4	§2.1051, §2.1057 §22.917	Conducted Spurious Emission at Antenna Terminal	PASS	2009-4-8
5	§22.913	Transmitter Radiated Power (EIPR/ERP)	PASS	2009-4-8
6	§2.1053, §2.1057 §22.917	Radiated Spurious Emission	PASS	2009-4-8
7	§2.1055, §22.355	Frequency Stability	PASS	2009-4-10
FCC Part 24 Requirement				
1	2.106, 24.229	Frequencies	PASS	2009-4-10
2	2.1046	Conducted RF Output Power	PASS	2009-4-10
3	2.1049	20dB Occupied Bandwidth	PASS	2009-4-10
4	2.1055, 24.235	Frequency Stability	PASS	2009-4-10
5	2.1051, 2.1057, 24.238	Conducted Out of Band Emissions	PASS	2009-4-10
6	2.1051, 2.1057, 24.238	Band Edge	PASS	2009-4-10
7	24.232	Transmitter Radiated Power (EIPR/ERP)	PASS	2009-4-10

2.3 Facilities and Accreditations

2.3.1 Facilities

Shenzhen Electronic Product Quality Testing Center Morlab Laboratory is a testing organization accredited by China National Accreditation Service for Conformity Assessment (CNAS) according to ISO/IEC 17025. The accreditation certificate number is CNAS L1659.

All measurement facilities used to collect the measurement data are located at Electronic Testing Building, Shahe Road, Xili, Nanshan District, Shenzhen, P. R. China. The site was constructed in conformance with the requirements of ANSI C63.7, ANSI C63.4 and CISPR Publication 22, the FCC registration number is 741109.

2.3.2 Test Equipments

No.	Description	Specification
1	System Simulator	Manufacturer: Rohde&Schwarz Model No.: CMU200 Serial No.: 100448
2	System Simulator	Manufacturer: Agilent Model No.: E5515C Serial No.: GB43130131
3	Spectrum Analyzer	Manufacturer: Agilent Model No.: E7405A Serial No.: US44210471
4	Telecommunication Antenna	Manufacturer: European Antennas Model No.: PSA-45010R/356 Serial No.: 403688-001
5	Trilogy Antenna	Manufacturer: Schwarzbeck Model No.: VULB 9163 Serial No.: 9163-274
6	Horn Antenna	Manufacturer: Schwarzbeck Model No.: BBHA 9120C Serial No.: 9120C-384
7	Power Splitter	Manufacturer: WEINSCHEL Model No.: 1506A Serial No.: NW521
8	Anechoic Chamber	Manufacturer: Albatross Projects GmbH
9	DC Power Supply	Manufacturer: Good Will Instrument Co., Ltd.
10	Temperature Chamber	Manufacturer: Chongqing YinHe Experimental Equip. Co., Ltd.

NOTE:

1. Equipments listed above have been calibrated and are in the period of validation.

2.3.3 Test Environment Conditions

During the measurement, the environmental conditions were within the listed ranges:

Temperature:	20 - 25°C
Relative Humidity:	40 - 60%
Atmospheric Pressure:	86-106kPa

3. 47 CFR Part 2, Part 22H, Part 22E Requirements

3.1 General Information

3.1.1 Conducted Related Tests

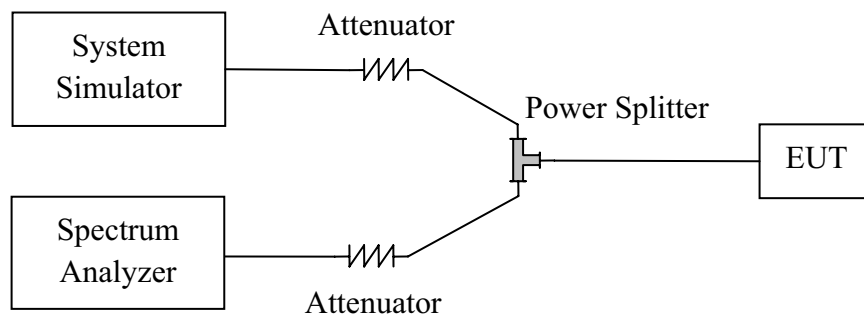

1. The EUT is coupled to the Spectrum Analyzer and the System Simulator with the suitable Attenuators through the Power Splitter; the path loss is calibrated to correct the reading.
2. The EUT is configured here as MS + USB-Power.
3. The EUT is commanded via the System Simulator (SS) to operate at the maximum output power. A communication link is established between the EUT and the SS.
4. The Spectrum Analyzer is set to max-peak detector function and maximum hold mode.

3.1.2 Radiated Power and Spurious Emission Tests

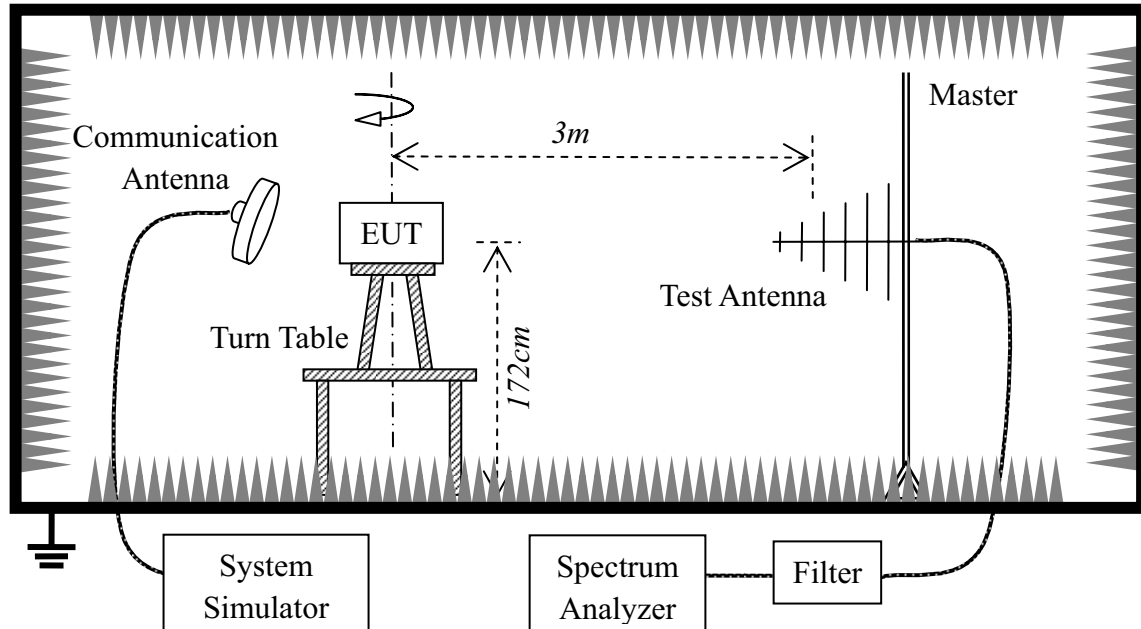

1. The test is performed in a full-Anechoic Chamber; the air loss of the site and the factors of the test system are pre-calibrated using the substitution method.
2. The EUT is configured as MS + USB-Power.
3. The EUT is placed on the vertical axis of a Turn Table 1.72 meters above the ground.
4. The Test Antenna is a bi-log one or a horn one, and the Test Antenna is at the same height as the EUT.
5. The EUT is commanded via the System Simulator (SS) to operate at the maximum output power. A communication link is established between the EUT and the SS.
6. The Spectrum Analyzer is set to max-peak detector function and maximum hold mode.

3.1.3 Frequency Stability Test

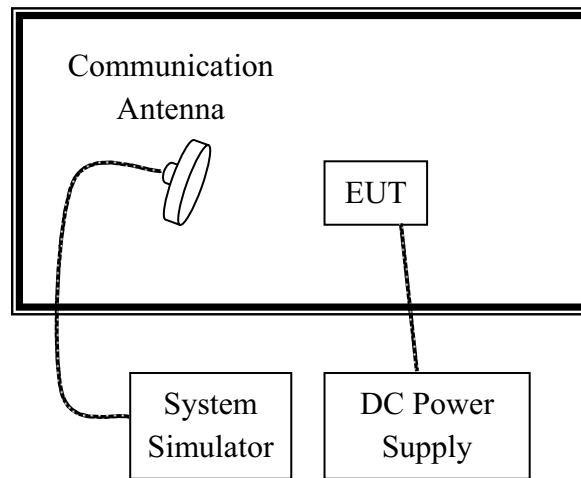

1. The test is performed in a Temperature Chamber.
2. The EUT is configured as MS + USB-Power.

3.2 Frequencies

3.2.1 Requirement

According to FCC §22.905, the frequencies blocks assignment for the Cellular Radiotelephone Service are listed as below.

- (a) Channel Block A:
 - Mobile 824 - 835MHz, Base 869 - 880MHz;
 - Mobile 845 - 846.5MHz, Base 890 - 891.5MHz
- (b) Channel Block B:
 - Mobile 835 - 845 MHz, Base 880 - 890MHz;
 - Mobile 846.5 - 849 MHz, Base 891.5 - 894MHz

According to FCC section 24.229, the frequencies available in the Broadband PCS services are listed as below, in accordance with the frequency allocations table of FCC section 2.106.

- (c) The following frequency blocks are available for assignment on an MTA basis:
 - Block A: 1850 - 1865MHz paired with 1930 - 1945MHz;
 - Block B: 1870 - 1885MHz paired with 1950 - 1965MHz
- (d) The following frequency blocks are available for assignment on a BTA basis:
 - Block C: 1895 - 1910 MHz paired with 1975 - 1990MHz;
 - Block D: 1865 - 1870 MHz paired with 1945 - 1950MHz;
 - Block E: 1885 - 1890 MHz paired with 1965 - 1970MHz;
 - Block F: 1890 - 1895 MHz paired with 1970 - 1975MHz.

3.2.2 Test Procedure

1. Perform test system setup as section 3.1.1.
2. The resolution bandwidth (RBW) of the Spectrum Analyzer was set to at least 1% of the emission bandwidth of the fundamental emission of the transmitter, e.g. for GSM modulated signal (here used): RBW=VBW=3kHz, for CDMA modulated signal: RBW=VBW=30kHz.
3. The lowest and the highest channel were selected to perform tests respectively. Channel No.1013 (lowest) and 777(highest) for CDMA800 MHz band. Channel No.25 (lowest) and 1175(highest) for CDMA1900 MHz band
4. The MS operated at the maximum output power. Set the Spectrum Analyzer suitably to capture the waveform, search peak and mark, and then record the plot.

3.2.3 Test Result

The frequencies of the lowest channel and the highest channel are as the following figures.

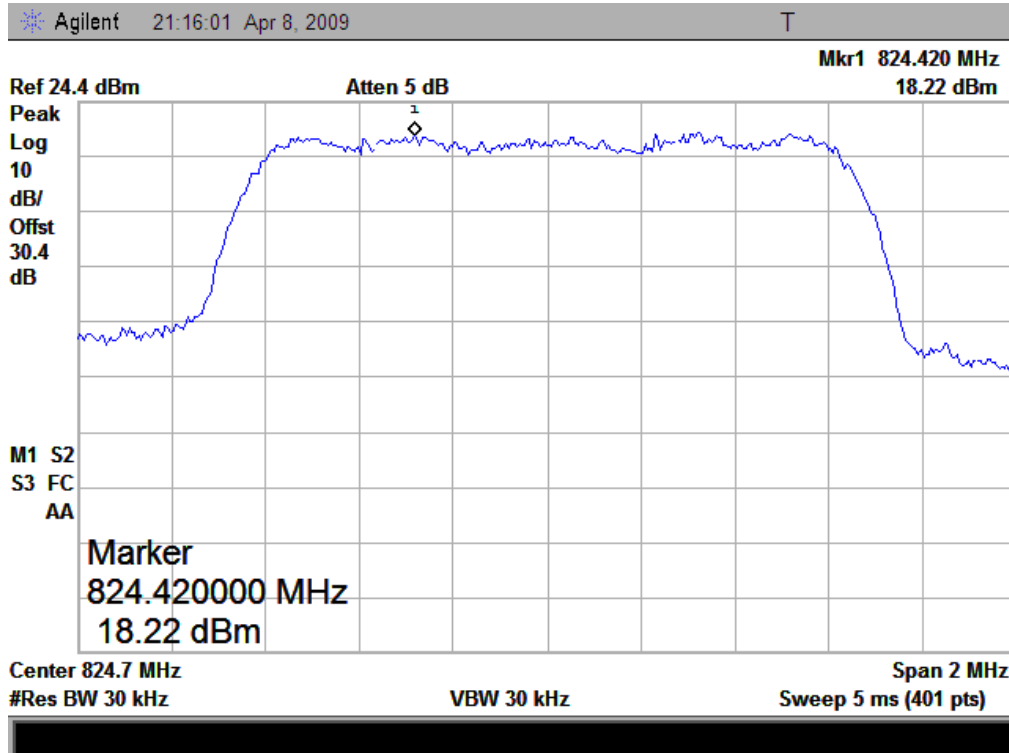

(Plot A: CDMA 800MHz Channel = 1013)

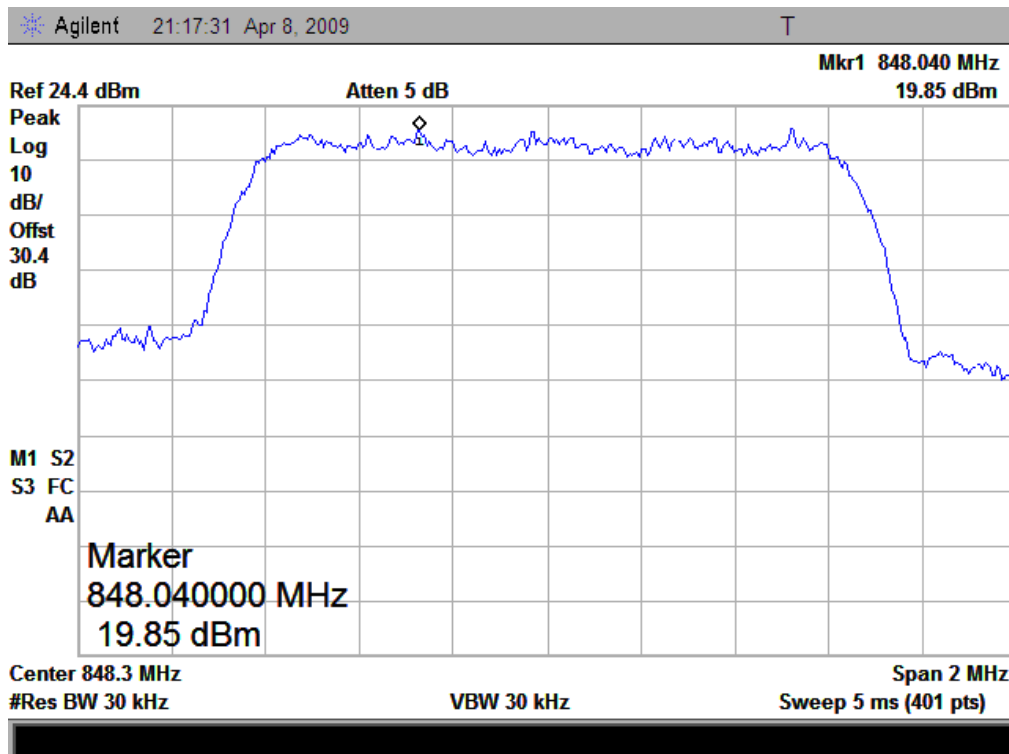

(Plot B: CDMA 800MHz Channel = 777)

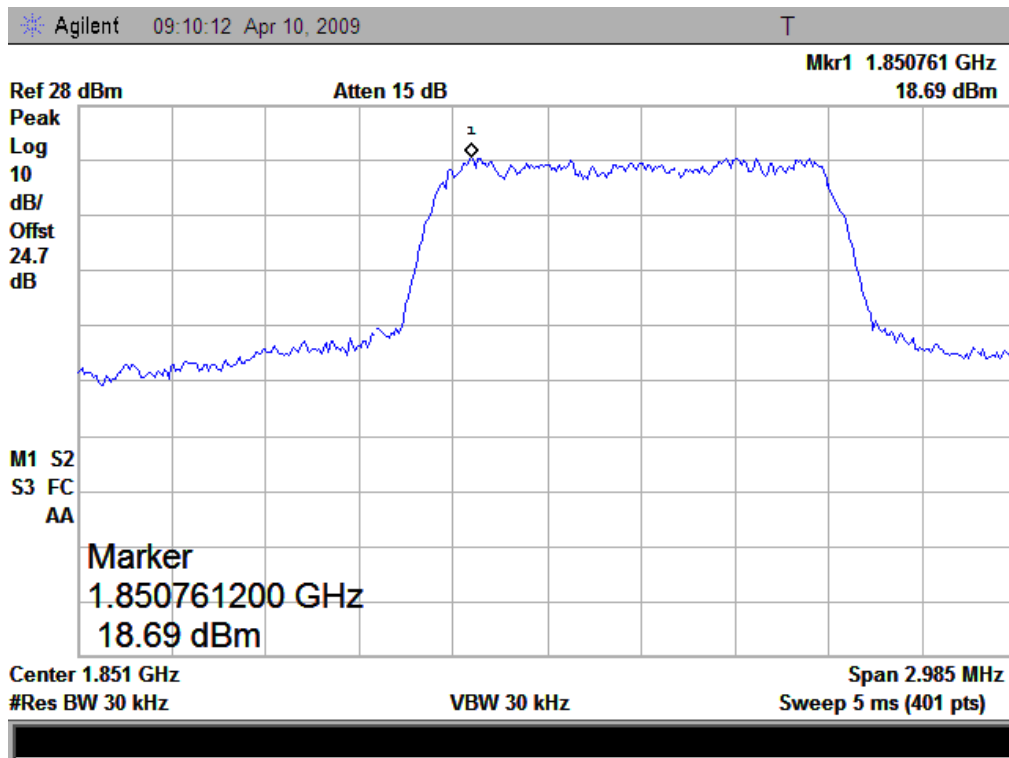

(Plot C: CDMA 1900MHz Channel = 25)

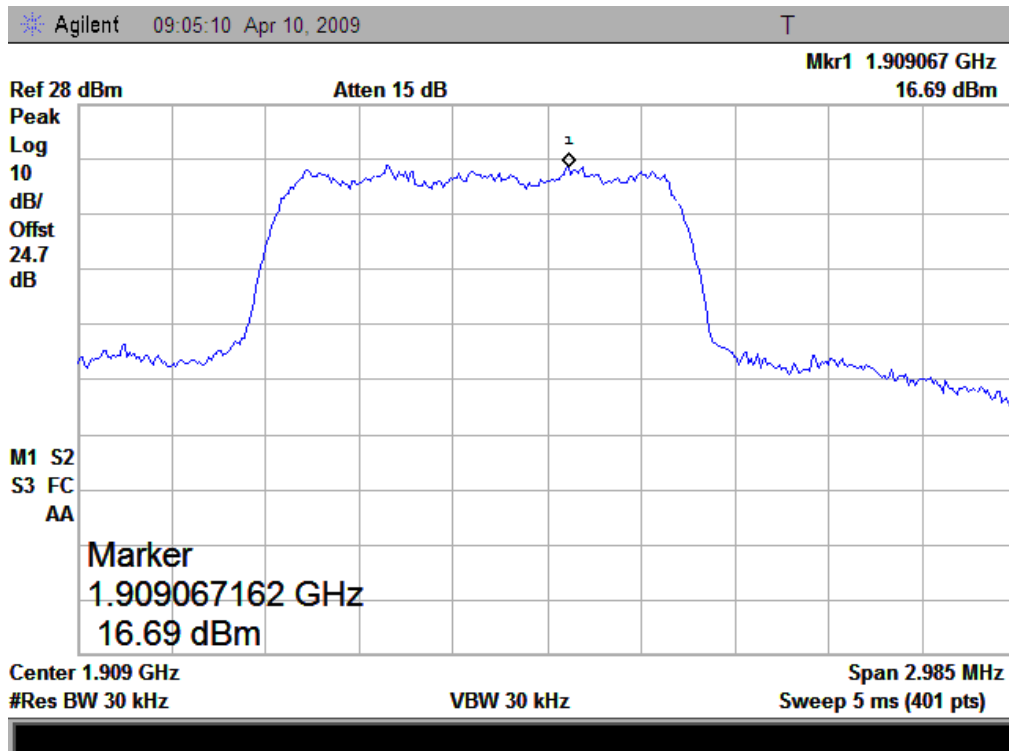

(Plot B: CDMA 800MHz Channel = 1175)

3.3 Conducted RF Output Power

3.3.1 Requirement

According to FCC §2.1046 (a), for transmitters other than single sideband, independent sideband and controlled carrier radiotelephone, power output shall be measured at the RF output terminals when the transmitter is adjusted in accordance with the tune-up procedure to give the values of current and voltage on the circuit elements specified in §2.1033 (c)(8). The electrical characteristics of the radio frequency load attached to the output terminals when this test is made shall be stated.

3.3.2 Test Procedure

1. Perform test system setup as section 3.1.1 (the radio frequency load attached to the EUT antenna terminal is 50Ω).
2. The resolution bandwidth of the Spectrum Analyzer is set to be comparable to the emission bandwidth of the transmitter, e.g. for GSM modulated signal (here used): RBW=VBW=1MHz, for CDMA modulated signal: RBW=VBW=3MHz.
3. The low, middle and the high channels are selected to perform tests respectively.
4. Set the frequency range of the Spectrum Analyzer suitably to capture the waveform; search peak and mark it; finally record the peak and the plot.

3.3.3 Test Result

No.	Channel Number	Frequency (MHz)	Measured Power		Rated Power	
			dBm	W	dBm	W
CDMA 800MHz	9	824.7	27.22	0.53	33	2
	384	836.52	28.6	0.72		
	777	848.31	28.05	0.64		
CDMA 1900MHz	25	1851.30	26.4	0.44	38.5	7
	600	1880.0	26.07	0.40		
	1175	1908.8	26.88	0.49		

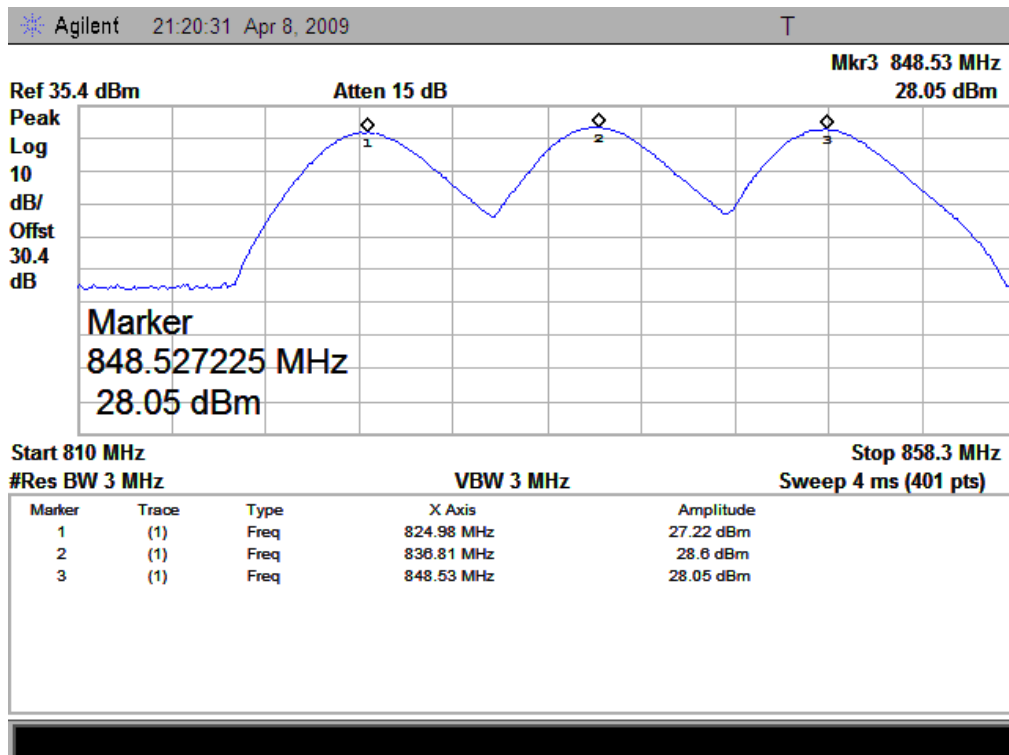

(Plot A: CDMA 800MHz Channel = 9, 384, 777)

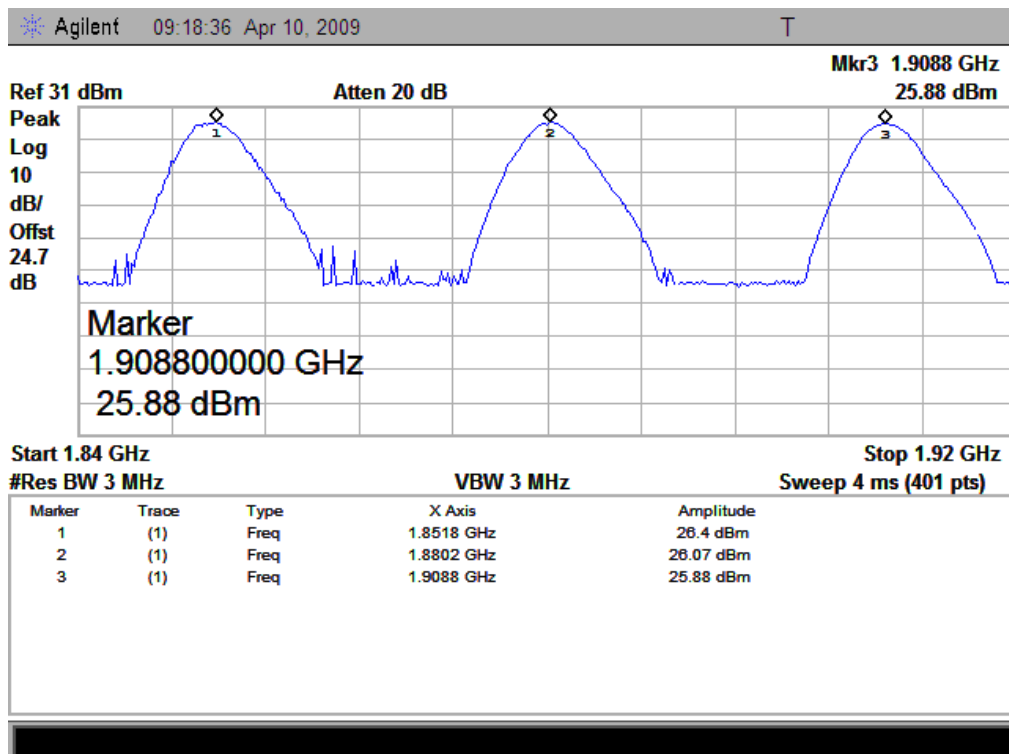

(Plot B: CDMA 1900MHz Channel = 25, 600, 1175)

3.4 Occupied Bandwidth

3.4.1 Occupied Bandwidth Definition

According to FCC §2.1049, the occupied bandwidth is the frequency bandwidth such that, below its lower and above its upper frequency limits, the mean powers radiated are each equal to 0.5 percent of the total mean power radiated by a given emission.

Occupied bandwidth is also known as the 99% emission bandwidth. The emission bandwidth is defined as the width of the signal between two points, one below the carrier center frequency and one above the carrier center frequency, outside of which all emissions are attenuated at least 26dB below the transmitter power.

3.4.2 Test Procedure

1. Perform test system setup as section 3.1.1.
2. The resolution bandwidth of the Spectrum Analyzer is set to at least one percent of the emission bandwidth, e.g. for GSM modulated signal (here used): RBW=VBW=3kHz, for CDMA modulated signal: RBW=VBW=30kHz.
3. The low, middle and the high channels are selected to perform tests respectively.
4. Set the frequency range of the Spectrum Analyzer suitably to capture the waveform; search peak; make a line whose value is 20dB lower than the peak; mark two points which the line intersected the waveform at; finally record the delta of the two points as the occupied bandwidth and the plot.

3.4.3 Test Result

Band	Channel	Frequency (MHz)	Measured 20dB Occupied Bandwidth (MHz)	Refer to Plot
CDMA 800MHz	9	824.7	1.400	Plot A
	384	836.52	1.405	Plot B
	777	848.31	1.405	Plot C
CDMA 1900MHz	25	1850.2	1.402	Plot D
	600	1880.0	1.402	Plot E
	1175	1909.8	1.410	Plot F

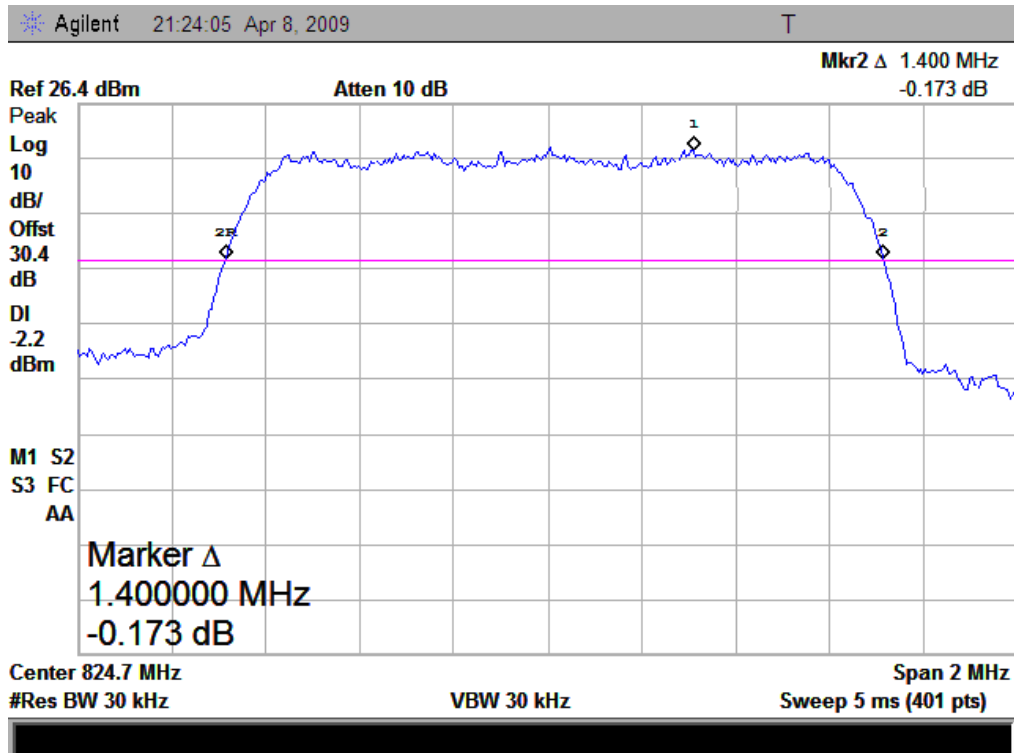

(Plot A: CDMA 800MHz Channel = 9)

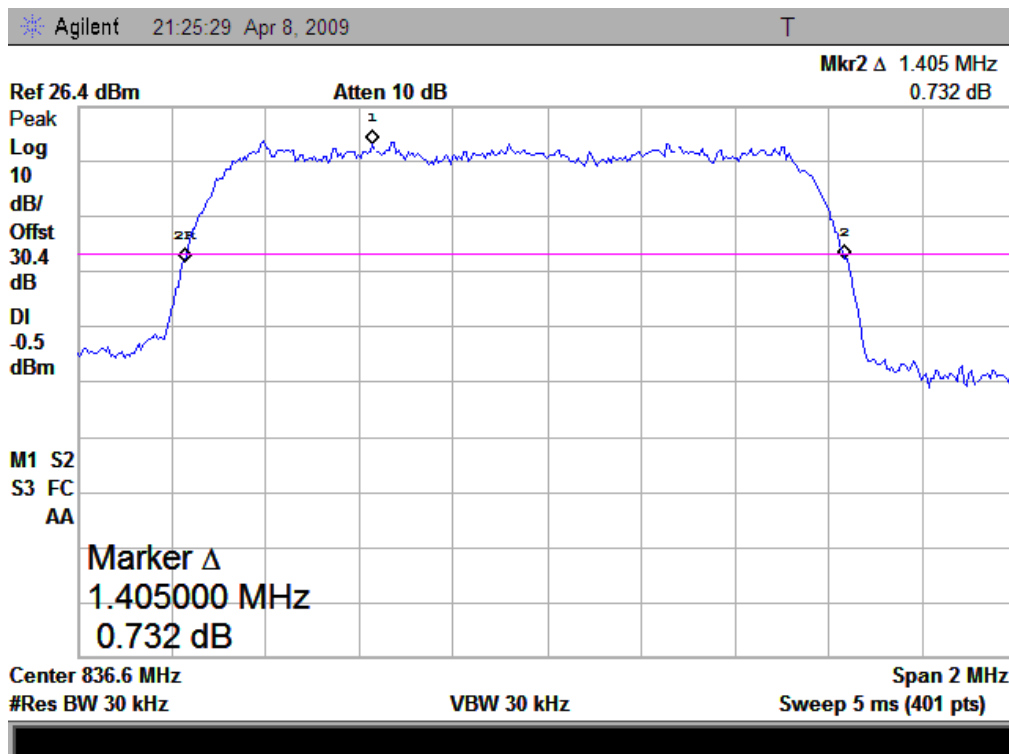

(Plot B: CDMA 800MHz Channel = 384)

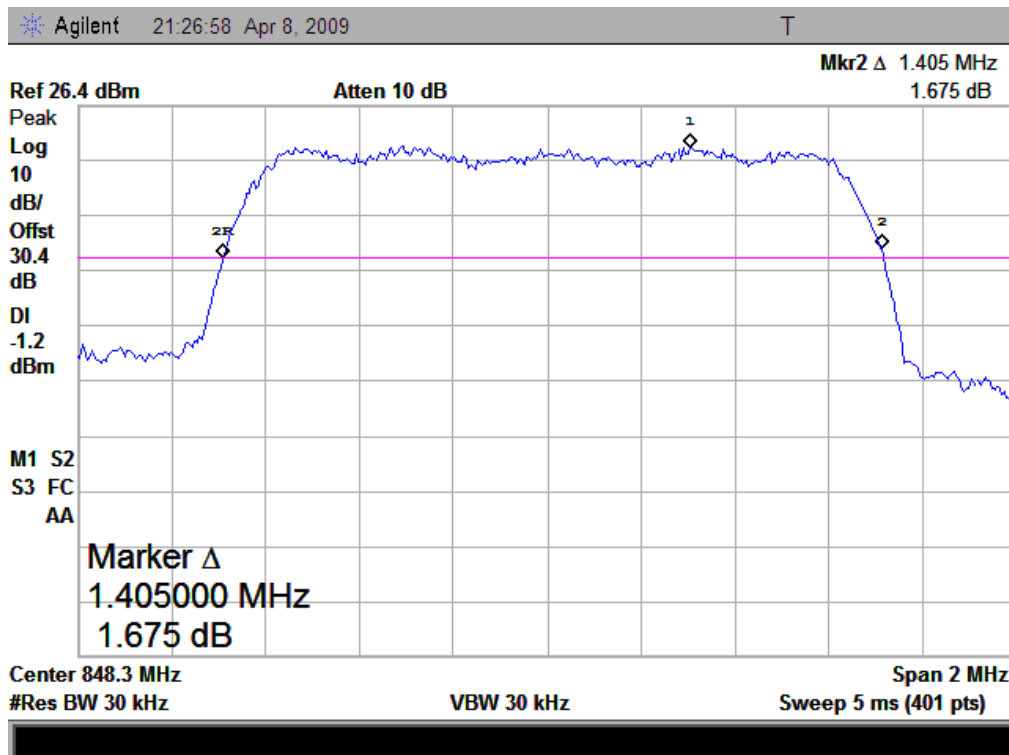

(Plot C: CDMA 800MHz Channel = 777)

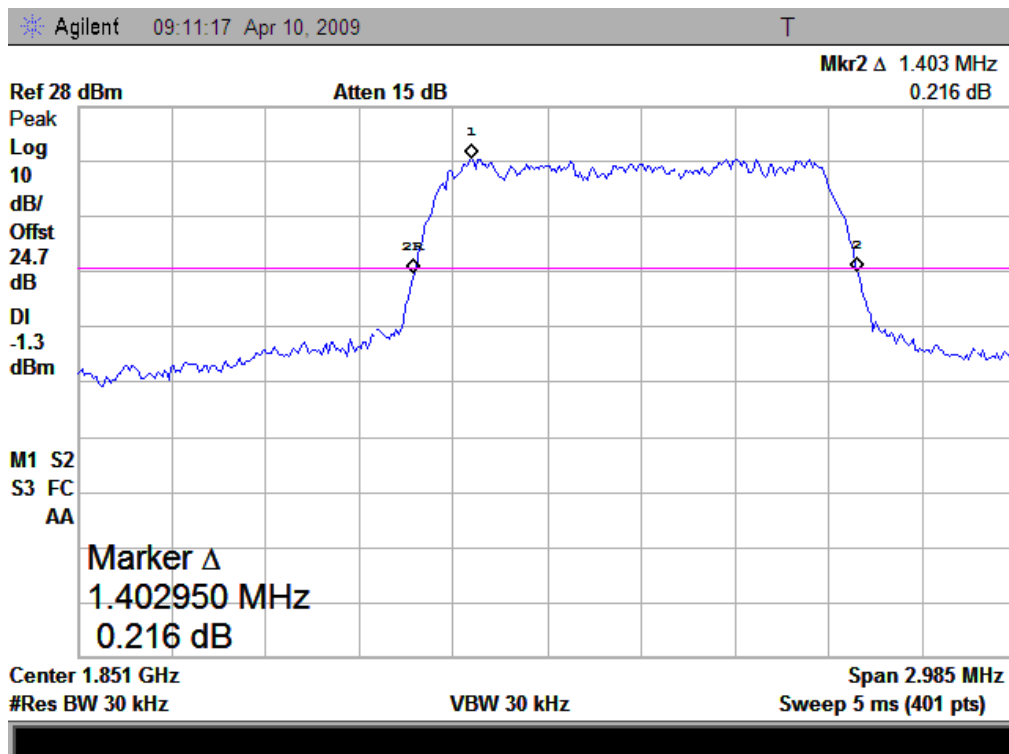

(Plot D: CDMA 1900MHz Channel = 25)

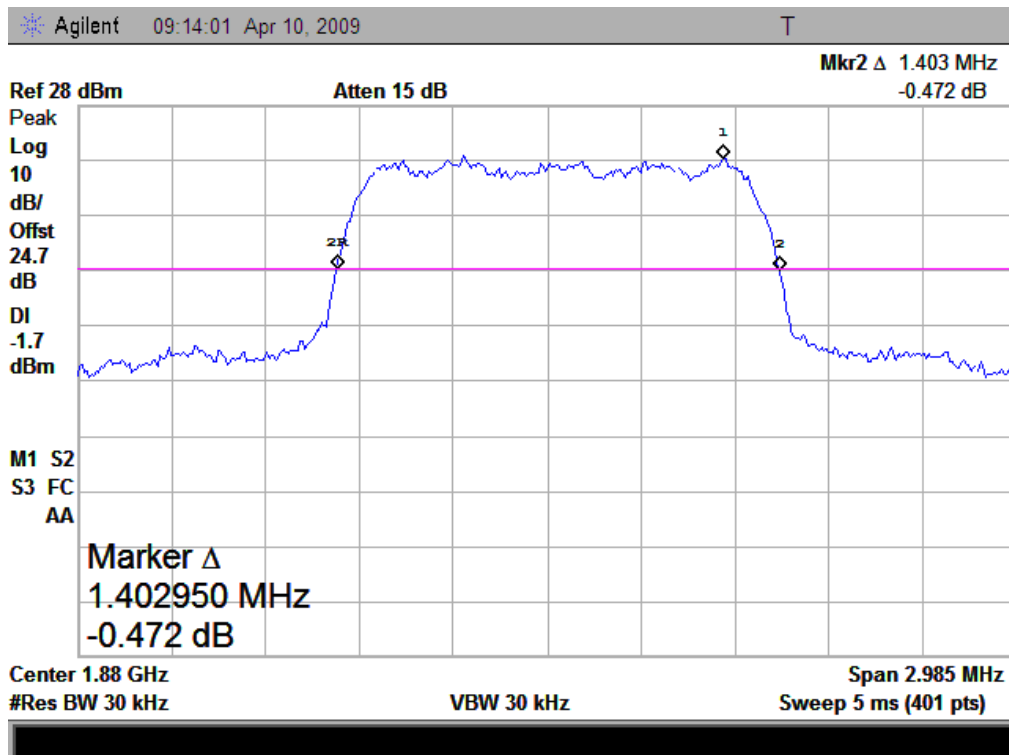

(Plot E: CDMA 1900MHz Channel = 600)

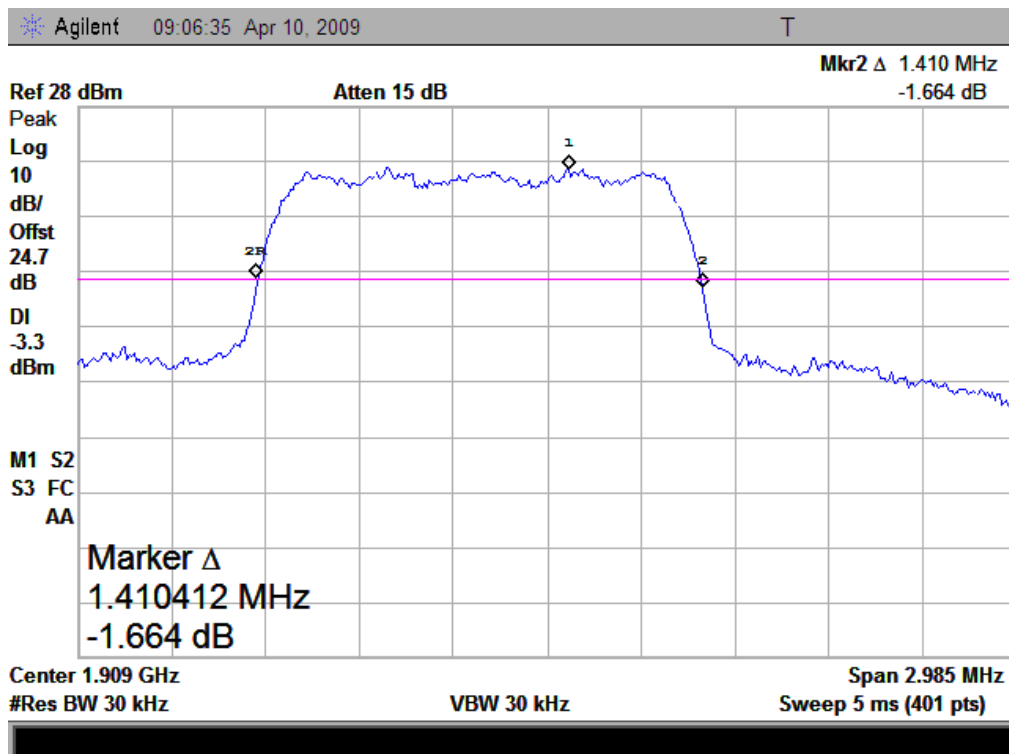

(Plot F: CDMA 1900MHz Channel = 1175)

3.5 Conducted Spurious Emission

3.5.1 Requirement

According to FCC §22.917(a) and 24.238(a), the power of any emission outside of the authorized operating frequency ranges must be attenuated below the transmitting power (P) by a factor of at least $43+10*\log(P)$ dB. This calculated to be -13dBm.

3.5.2 Test Procedure

1. Perform test system setup as section 3.1.1.
2. Make a limit line whose value is -13dBm on the Spectrum Analyzer.
3. The lowest, middle and the highest channels are selected to perform tests respectively.
4. Set the RBW of the Spectrum Analyzer to 1MHz, and the measuring frequency range from 9kHz to 10th harmonic of the fundamental frequency (here used 10GHz); mark the fundamental frequency and the harmonics thereof; finally record the harmonics and the plot. Note: the measuring frequency range can be divided into several parts to perform tests.
5. In the 1MHz bands immediately outside and adjacent to the frequency block, the RBW of the Spectrum Analyzer was set to at least one percent of the emission bandwidth of the fundamental emission of the transmitter, e.g. for GSM modulated signal (here used): RBW=3kHz, for CDMA modulated signal: RBW=30kHz.

3.5.3 Test Result

3.5.3.1 Table for the Harmonics and Plots for the Spurious Emission

1. Table for the Harmonics:

No.	Channel	Frequency(MHz)	Measured Max Spurious Emission(dBm)	Limit(dBm)
CDMA 800MHz	1013	824.7	<-20	-13
	384	836.52	<-20	-13
	777	848.31	<-20	-13
CDMA 1900MHz	1013	824.7	<-20	-13
	384	836.52	<-20	-13
	777	848.31	<-20	-13

2. Plot for Spurious Emission:

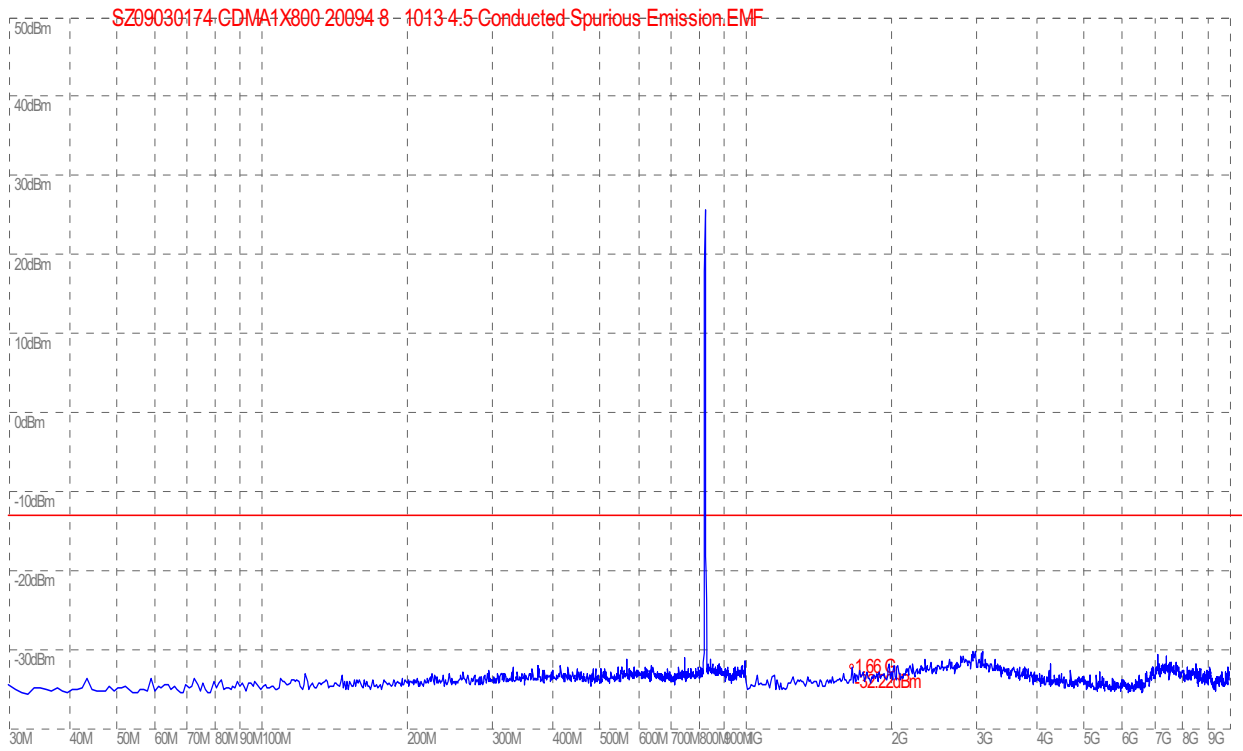

(Plot A: CDMA 800MHz Channel = 1013, 30MHz to 3GHz)

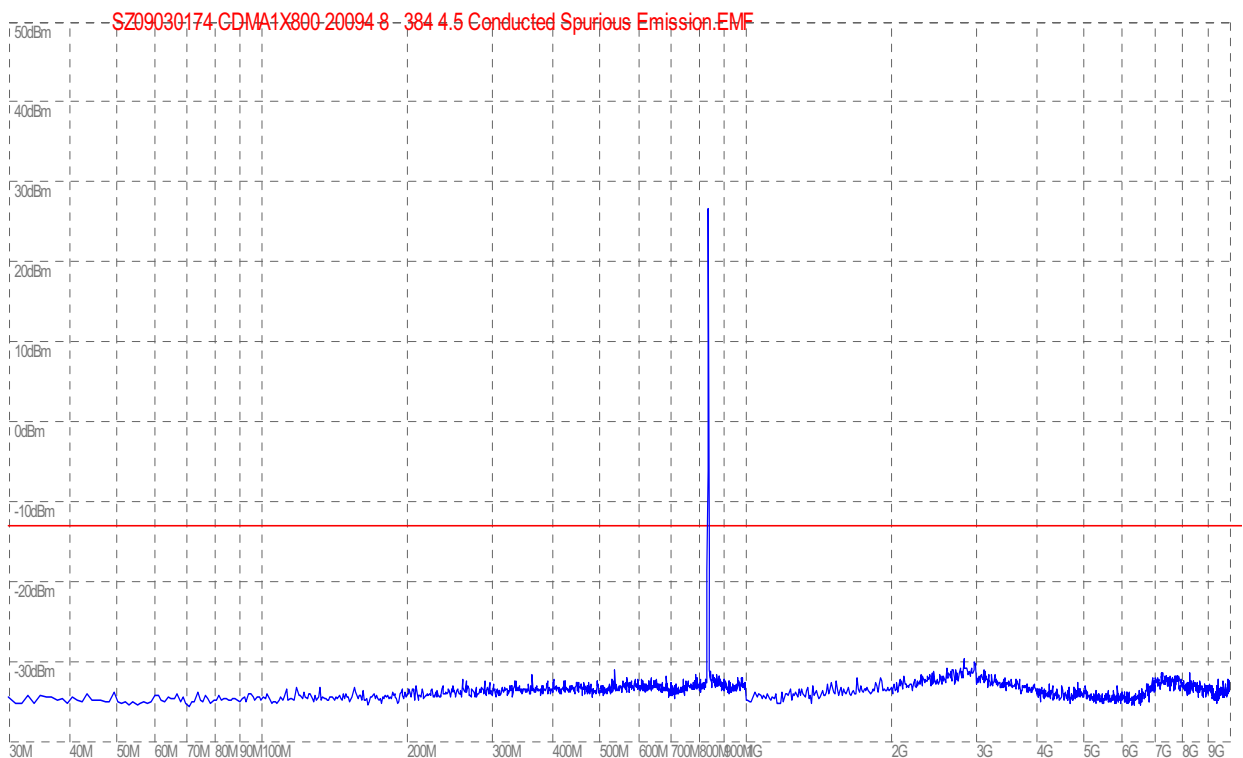

(Plot B: CDMA 800MHz Channel = 384, 30MHz to 3GHz)

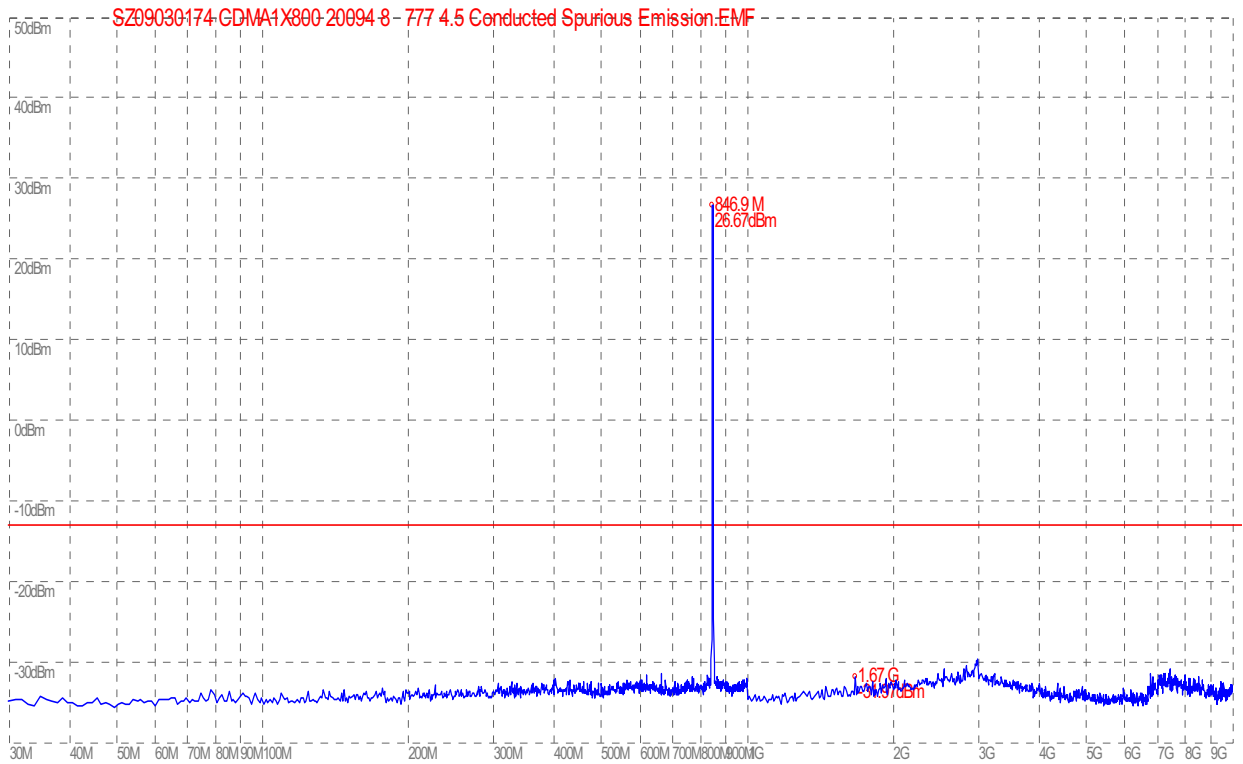

(Plot C: CDMA 800MHz Channel = 777, 30MHz to 3GHz)

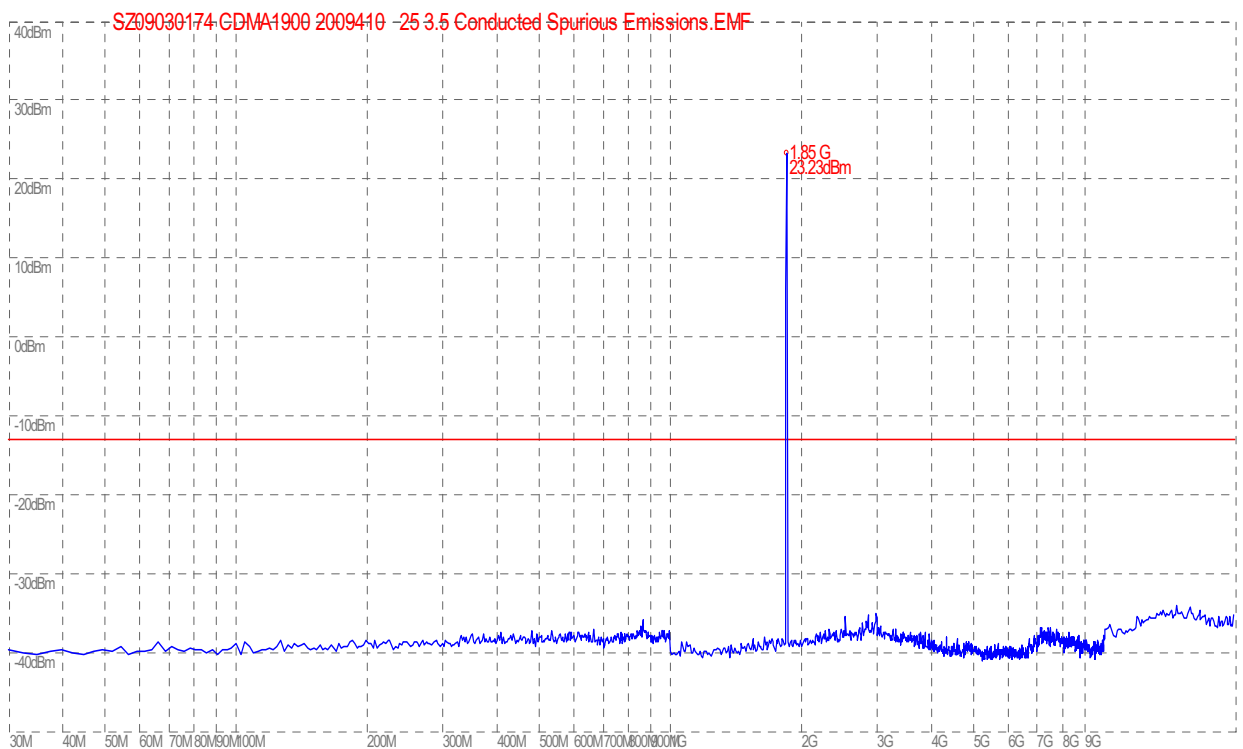

(Plot D: CDMA 1900MHz Channel = 25, 30MHz to 20GHz)

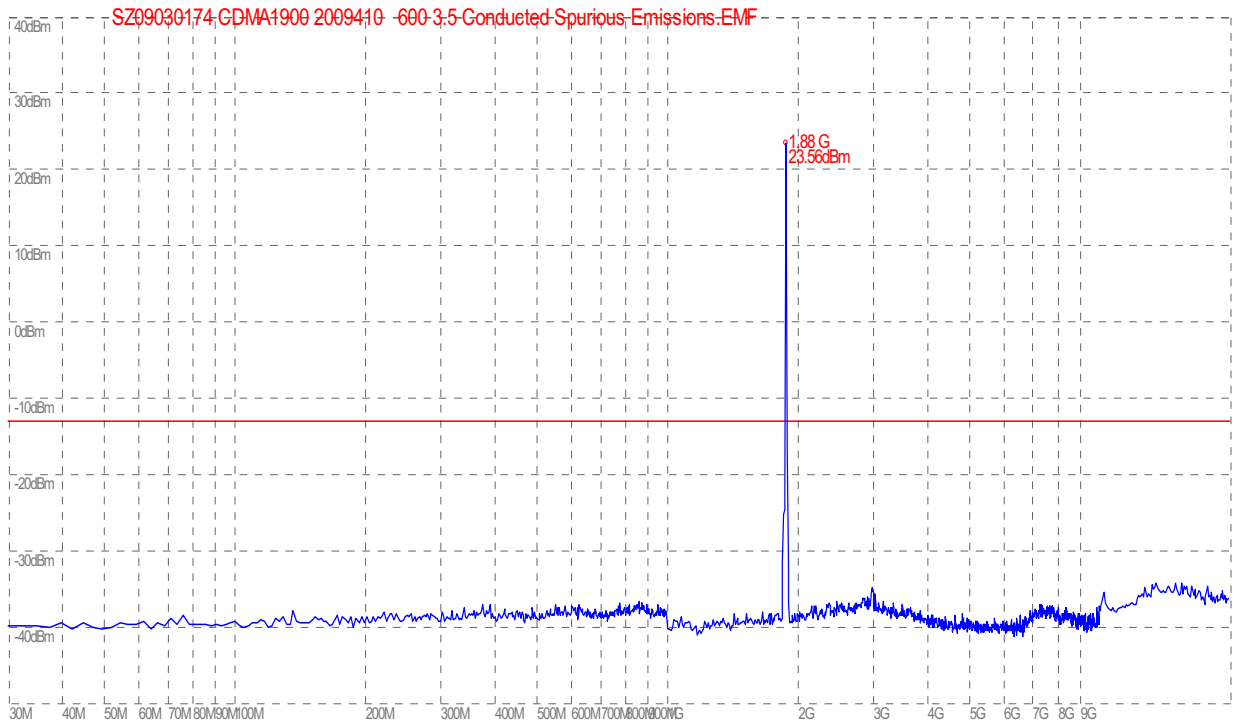

(Plot E: CDMA 1900MHz Channel = 600, 30MHz to 20GHz)

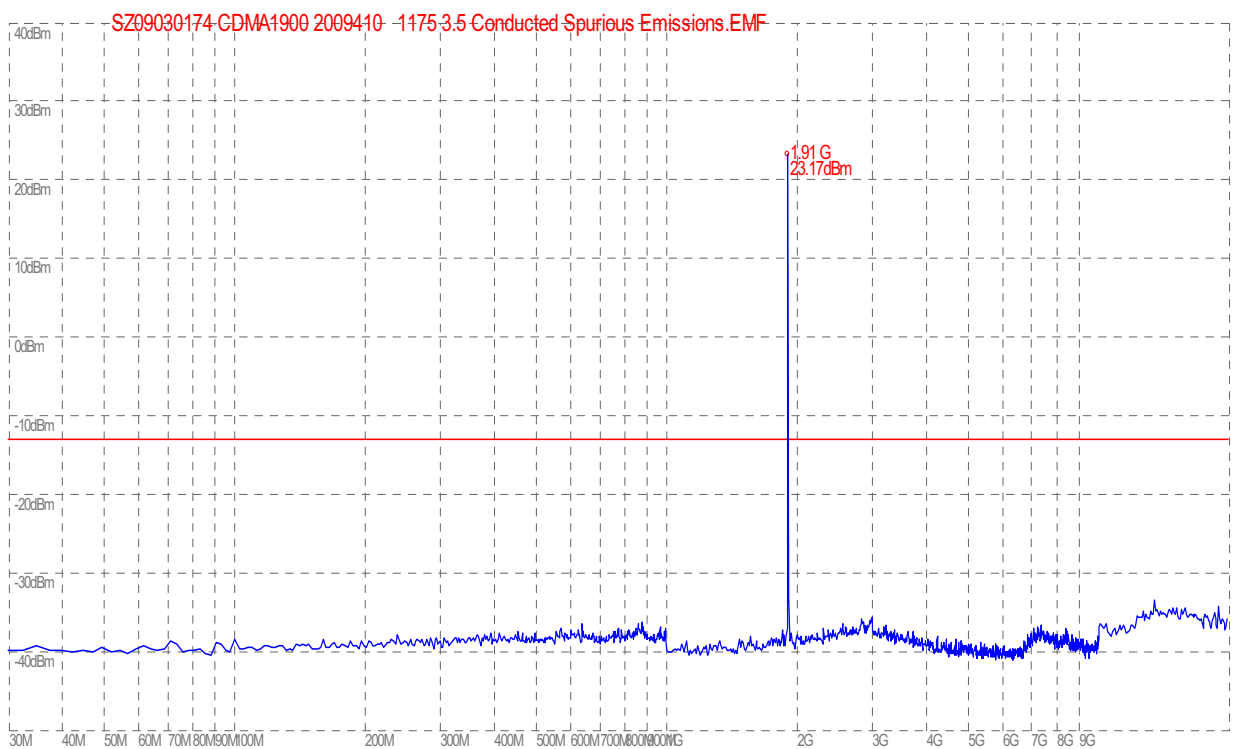

(Plot F: CDMA 1900MHz Channel = 1175, 30MHz to 20GHz)

3.6 Band Edge

3.6.1 Requirement

According to FCC section 22.917(b) and FCC section 24.238(b), in the 1MHz bands immediately outside and adjacent to the frequency block a resolution bandwidth of at least one percent of the emission bandwidth (26dB emission bandwidth) of the fundamental emission of the transmitter may be employed.

3.6.2 Test Result

The lowest and highest channels are tested to verify the band edge emissions.

1. Test Verdict:

Band	Channel	Frequency (MHz)	Measured Max. Band Edge Emission (dBm)	Refer to Plot	Limit (dBm)	Verdict
CDMA 800MHz	1013	824.7	-16.65	Plat A	-13	PASS
	777	848.31	-24.44	Plot B		PASS
CDMA 1900MHz	25	1851.2	-19.18	Plat C	-13	PASS
	1175	1908.8	-18.10	Plot D		PASS

2. Plot

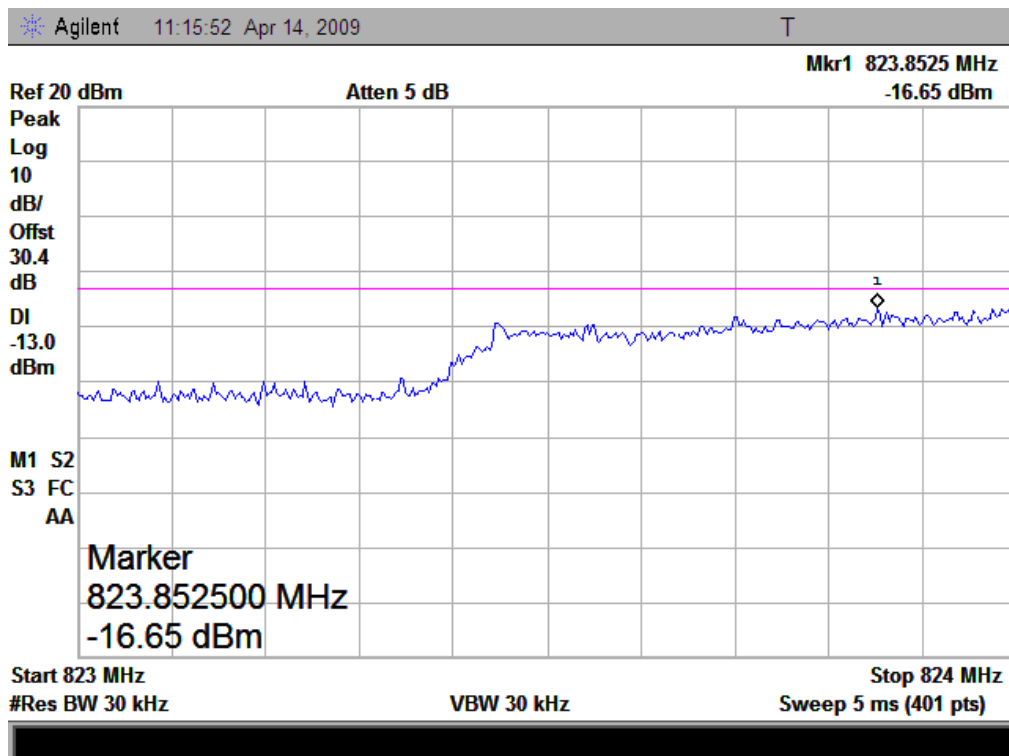



(Plot A: CDMA 800MHz Channel = 1013)

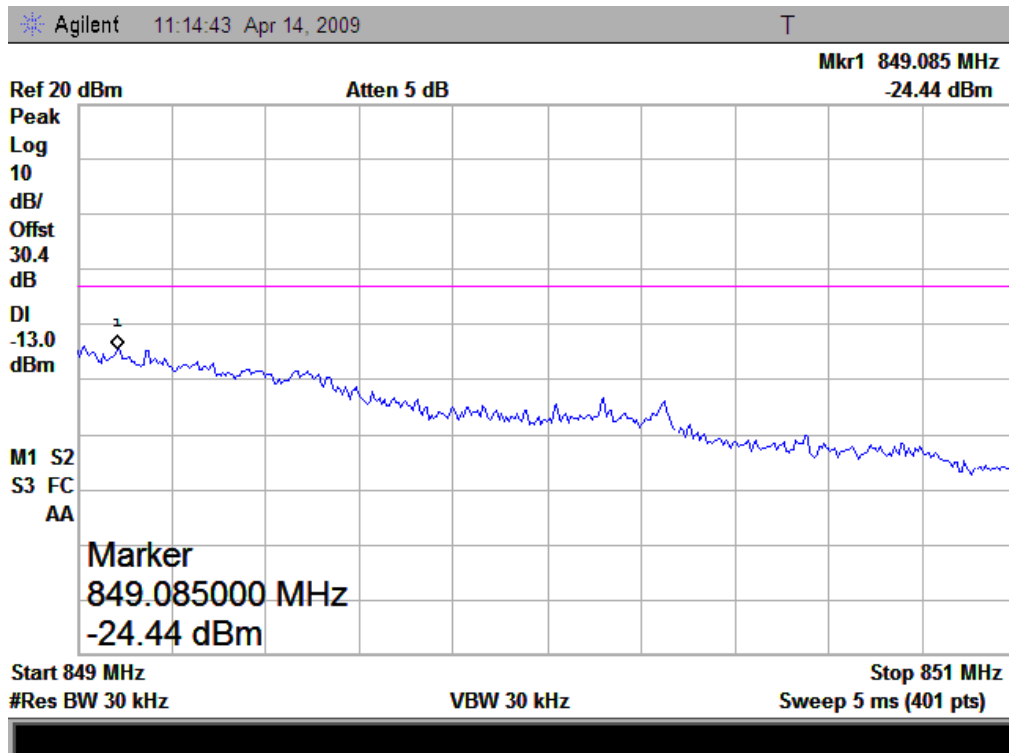

(Plot B: CDMA 800MHz Channel = 777)

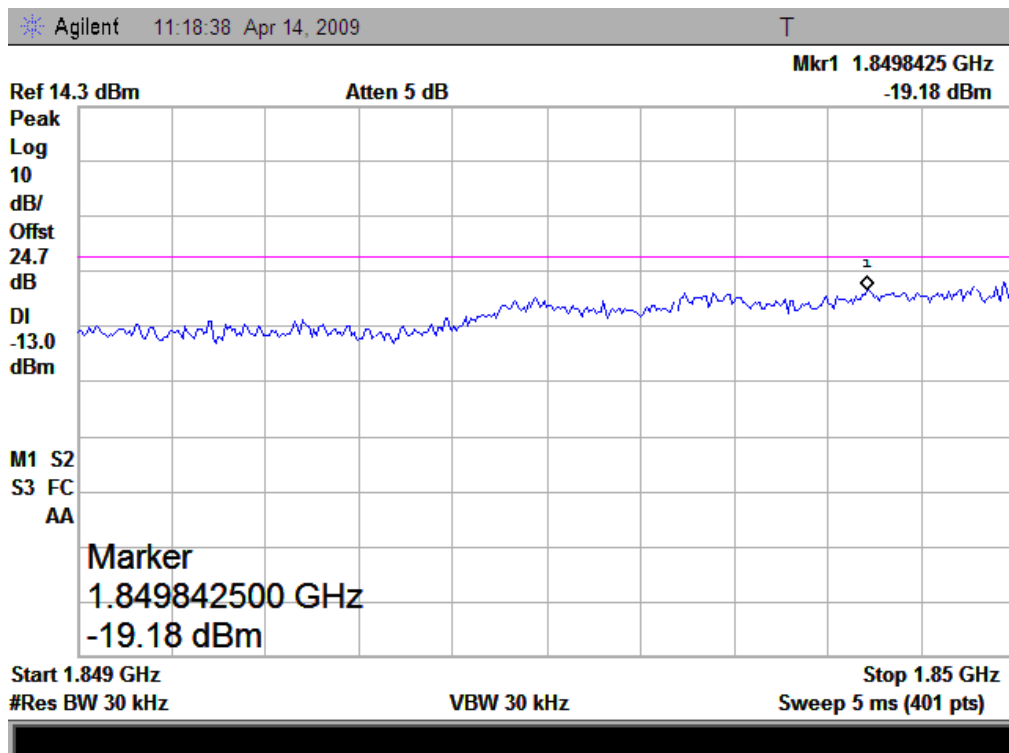

(Plot C: CDMA 1900MHz Channel = 25)

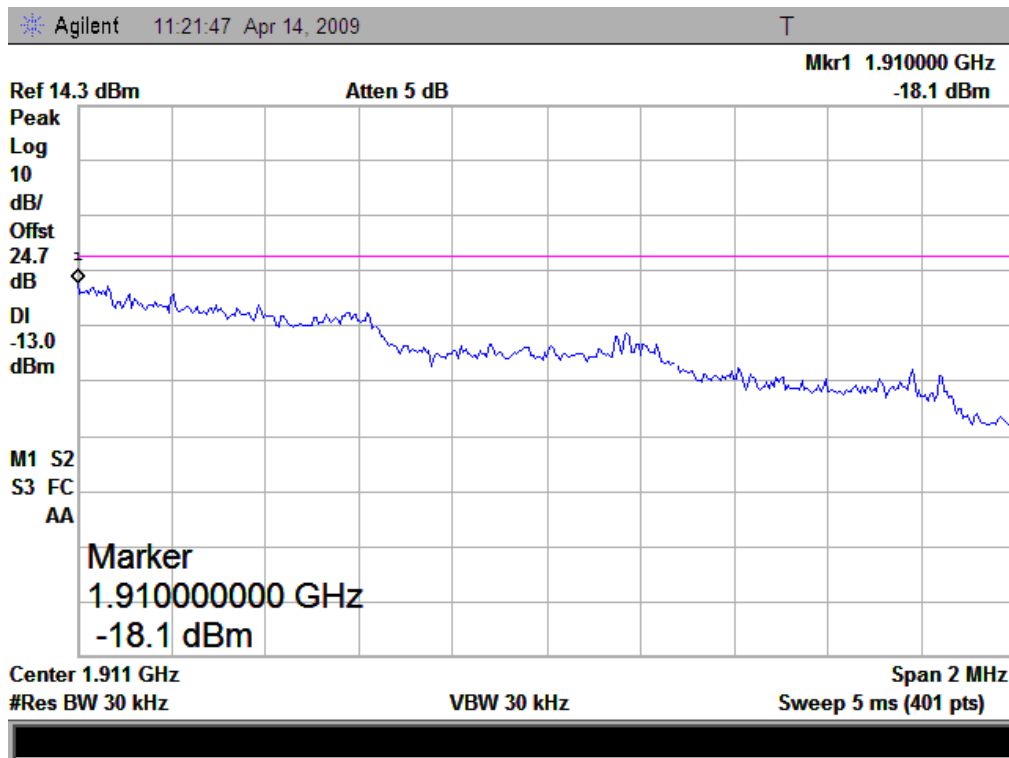

(Plot D: CDMA 1900MHz Channel = 1175)

3.7 Transmitter Radiated Power (EIRP/ERP)

3.7.1 Requirement

According to FCC §22.913 and section 24.232, the ERP of Cellular mobile transmitters must not exceed 7 Watts and 2Watts.

3.7.2 Test Procedure

1. Perform test system setup as section 3.1.2.
2. The resolution bandwidth of the Spectrum Analyzer is set to be comparable to the emission bandwidth of the transmitter, e.g. for GSM modulated signal (here used): RBW=VBW=1MHz, for CDMA modulated signal: RBW=VBW=3MHz.
3. The low, middle and the high channels are selected to perform tests respectively.
4. Employ the bi-log Test Antenna as the test system receiving antenna; set the polarization of the Test Antenna to be the same as that of the EUT transmitting antenna.
5. Set the frequency range of the Spectrum Analyzer suitably to capture the waveform; actuate the Turn Table to turn from 0 degrees to 360 degrees to find the maximum reading via the Spectrum Analyzer, mark the peak; finally record the peak and the plot.

3.7.3 Test Result

1. Test Verdict:

No.	Channel	Frequency (MHz)	Measured ERP		Limit ERP	
			dBm	W	dBm	W
CDMA 800MH z	1013	824.7	23.18	0.21	38.5	7
	384	836.52	24.43	0.28		
	777	848.31	22.90	0.19		
CDMA 1900M Hz	25	1850.2	19.01	0.08	33	2
	600	1880.0	15.96	0.04		
	1175	1909.8	16.39	0.04		

2. The plots:

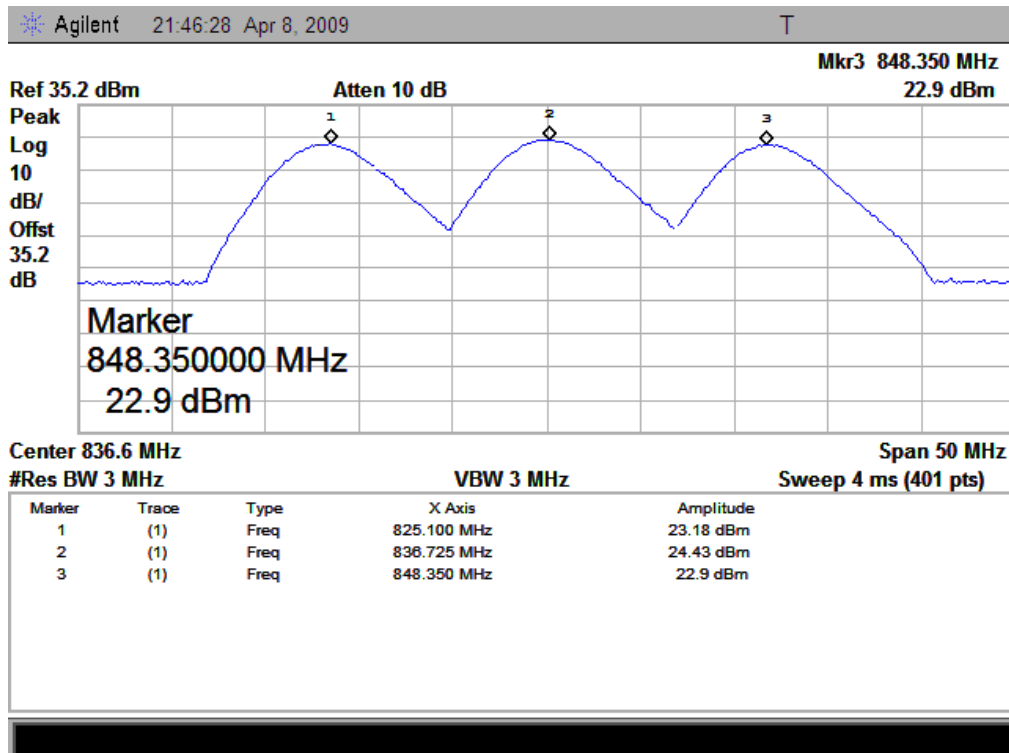

(Plot A: CDMA 800MHz Channel = 9, 384, 777)

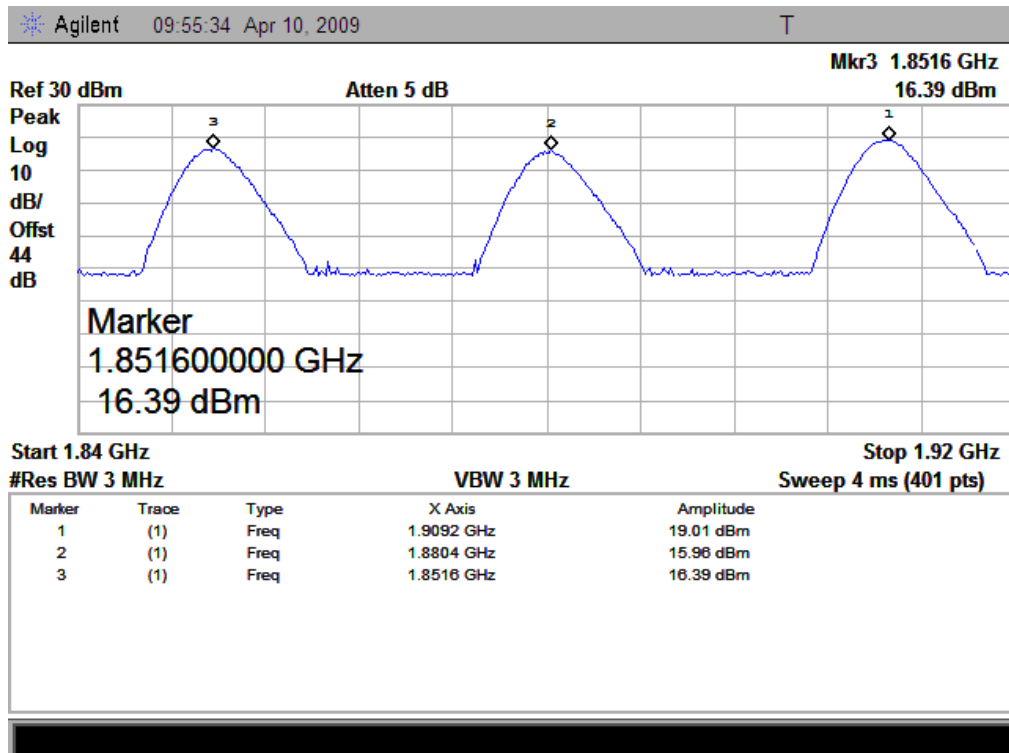

(Plot B: CDMA 1900MHz Channel = 25, 600, 1175)

3.8 Radiated Spurious Emission

3.8.1 Requirement

According to FCC §22.917(a), the power of any emission outside of the authorized operating frequency ranges must be attenuated below the transmitting power (P) by a factor of at least $43+10*\log(P)$ dB. This calculated to be -13dBm.

3.8.2 Test Procedure

1. Perform test system setup as section 3.1.2.
2. Make a limit line whose value is -13dBm on the Spectrum Analyzer, and set the RBW of the Spectrum Analyzer to 1MHz.
3. The low, middle and the high channels are selected to perform tests respectively.
4. Employ the bi-log Test Antenna as the test system receiving antenna and set the frequency range of the Spectrum Analyzer from 30MHz to 3GHz.
5. The measurement is performed with the Test Antenna at both horizontal and vertical polarization respectively. Set the polarization of the Test Antenna to be horizontal.
6. Actuate the Turn Table to turn from 0 degrees to 360 degrees to find the maximum reading via the Spectrum Analyzer, mark the fundamental frequency and the harmonics thereof, after then record the harmonics and the plot.
7. Set the polarization of the Test Antenna to be vertical, then repeat step 6.
8. Employ the horn Test Antenna as the test system receiving antenna and set the frequency range of the Spectrum Analyzer from 3GHz to 10th harmonic of the fundamental frequency (here used 10GHz for CDMA800MHz and 20GHz for CDMA1900MHz).

3.8.3 Test Result

The measurement frequency range is from 30MHz to the 10th harmonic of the fundamental frequency. The Turn Table is actuated to turn from 0° to 360°, and both horizontal and vertical polarizations of the Test Antenna are used to find the maximum radiated power. The lowest, middle and highest channels are tested to verify the out of band emissions.

1. Test Verdict:

Band	Channel	Frequency (MHz)	Measured Max. Spurious Emission (dBm)		Refer to Plot	Limit (dBm)	Verdict
			Test Antenna Horizontal	Test Antenna Vertical			
CDMA 800MHz	1013	1649	-46.12	< -25	Plot A.1/A.2	-13	PASS
	384	1673	-36.32	-33.6	Plot B.1/B.2		PASS
	777	1696	-42.2	-39.6	Plot C.1/C.2		PASS
CDMA 1900MHz	25	3700	< -25	< -25	Plot D.1/D.2	-13	PASS
	600	3760	< -25	< -25	Plot E.1/E.2		PASS
	1175	1909.8	< -25	< -25	Plot F.1/F.2		PASS

2. Test Plot for the Whole Measurement Frequency Range:

Note: the power of the EUT transmitting frequency should be ignored.

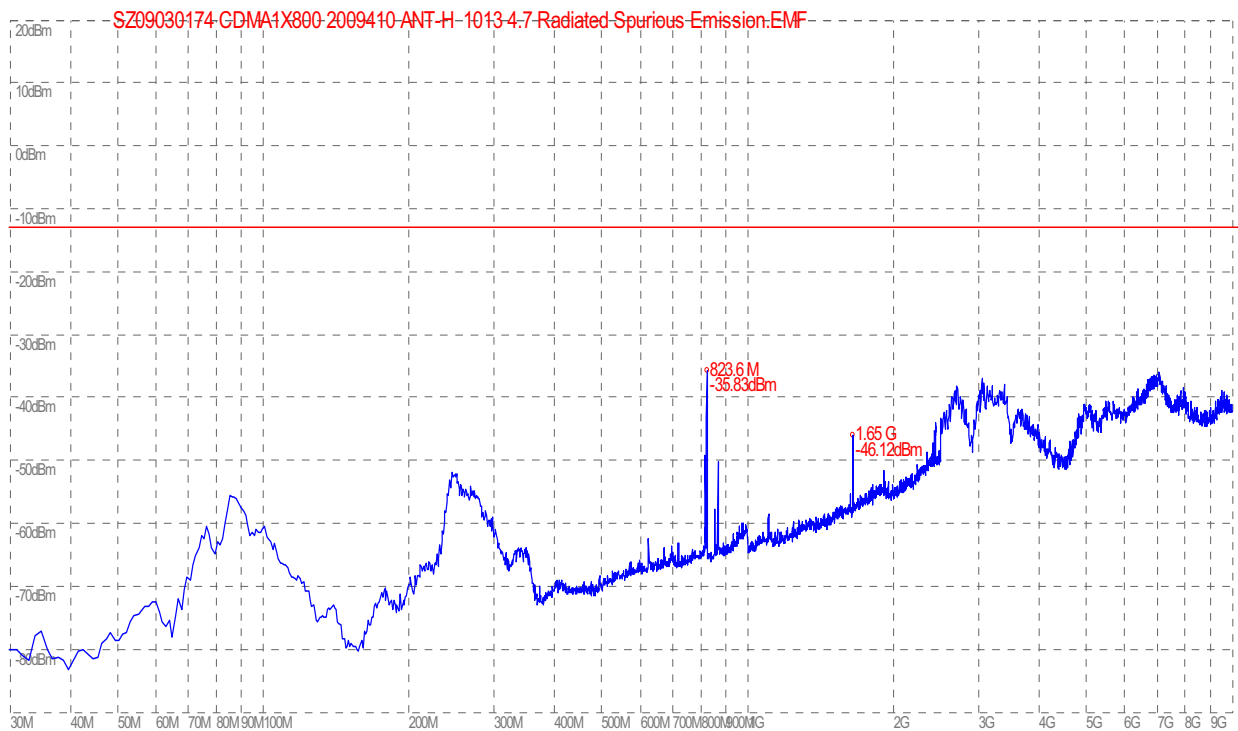

(Plot A.1: CDMA 800MHz Channel = 1013, Test Antenna Horizontal)

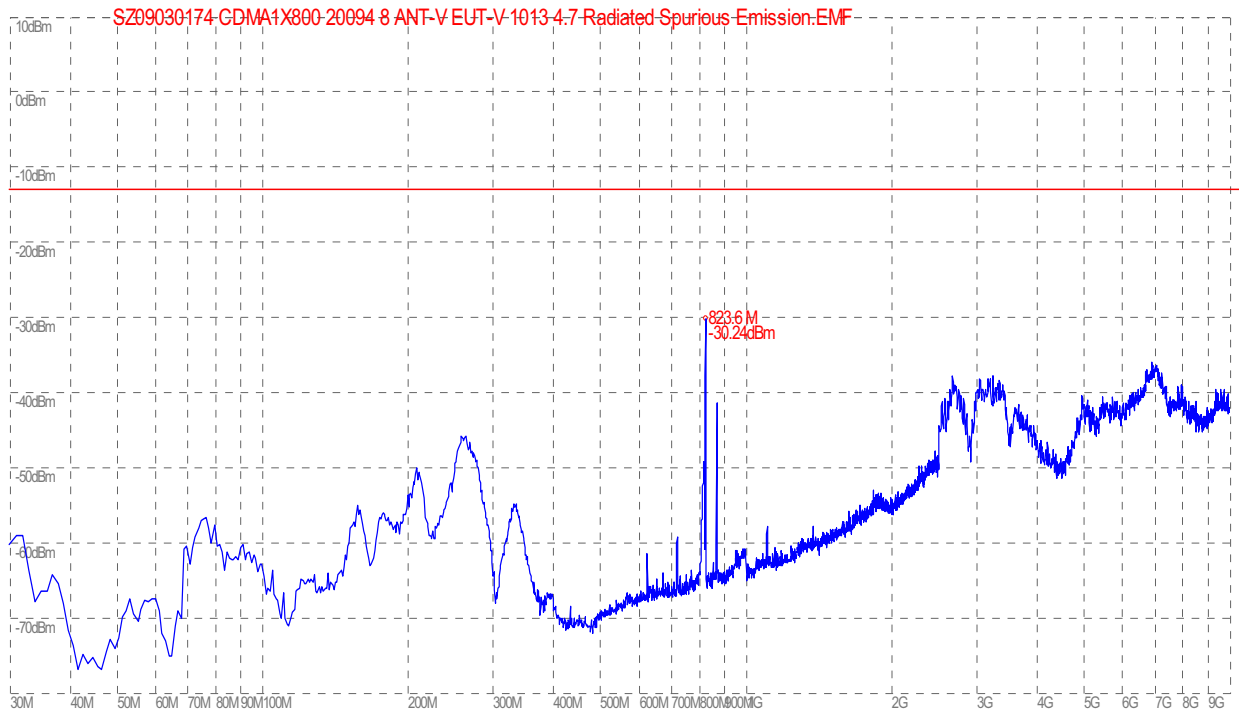

(Plot A.2: CDMA 800MHz Channel = 1013, Test Antenna Vertical)

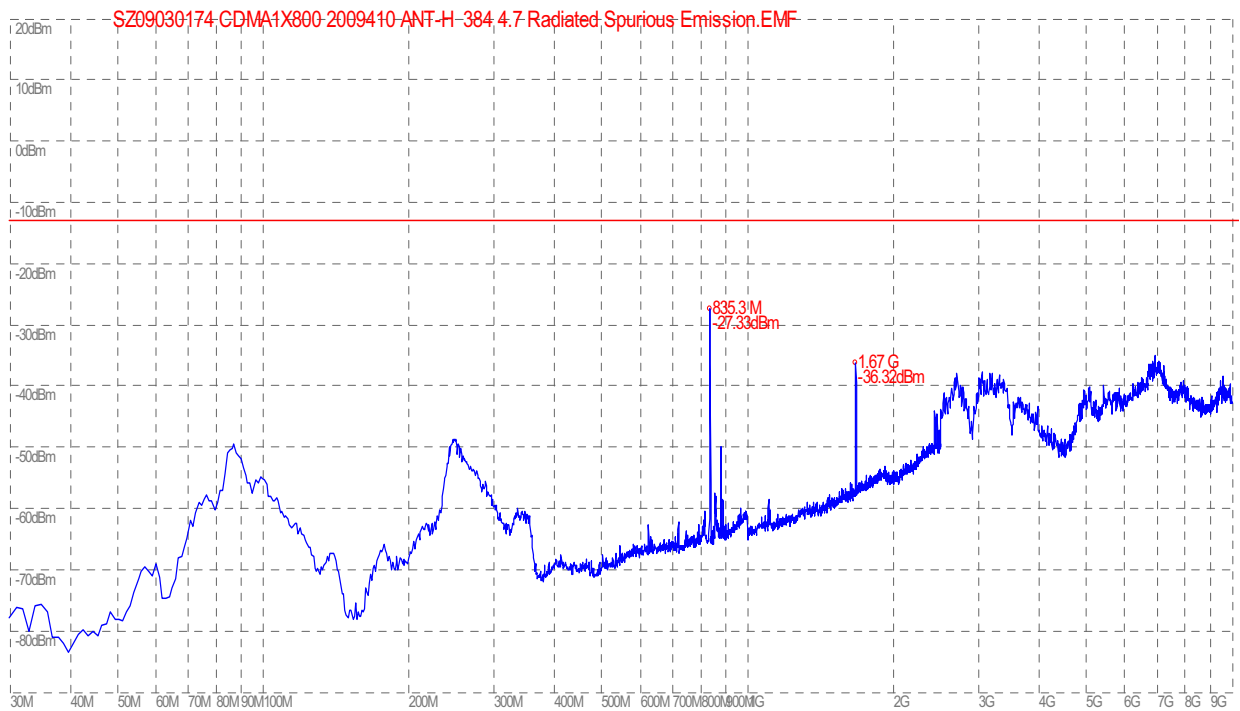

(Plot B.1: CDMA 800MHz Channel = 384, Test Antenna Horizontal)

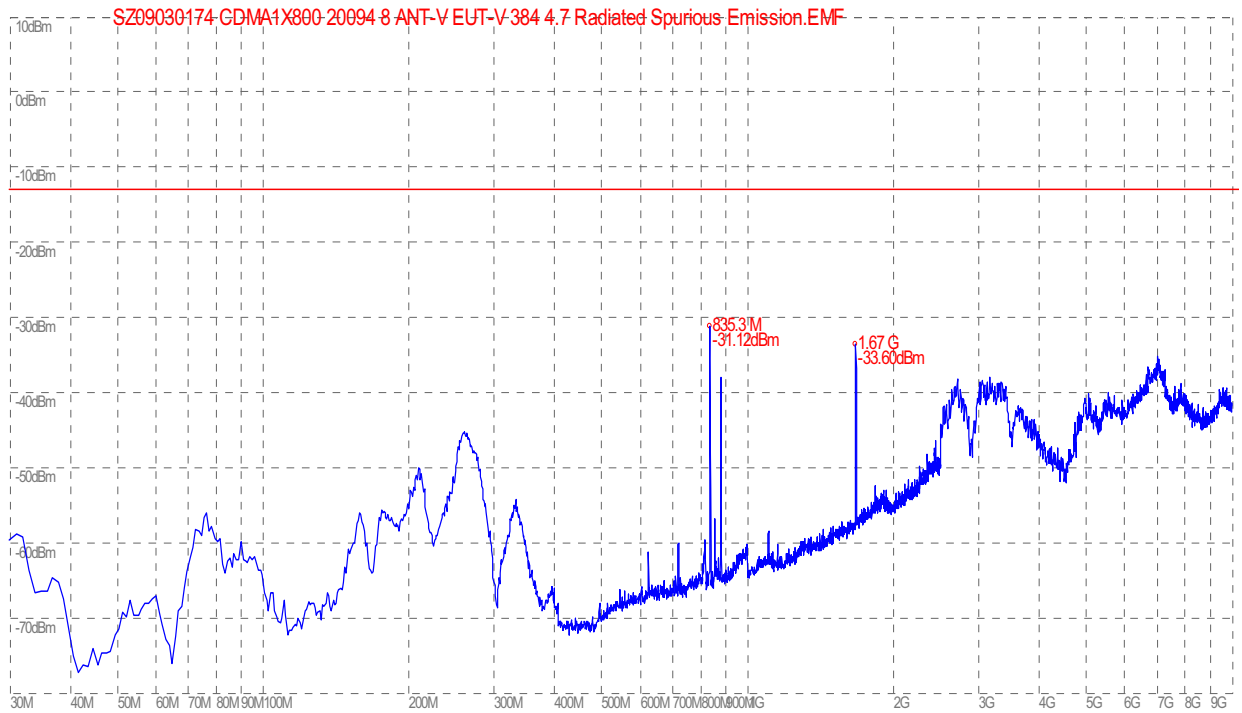

(Plot B.2: CDMA 800MHz Channel = 384, Test Antenna Vertical)

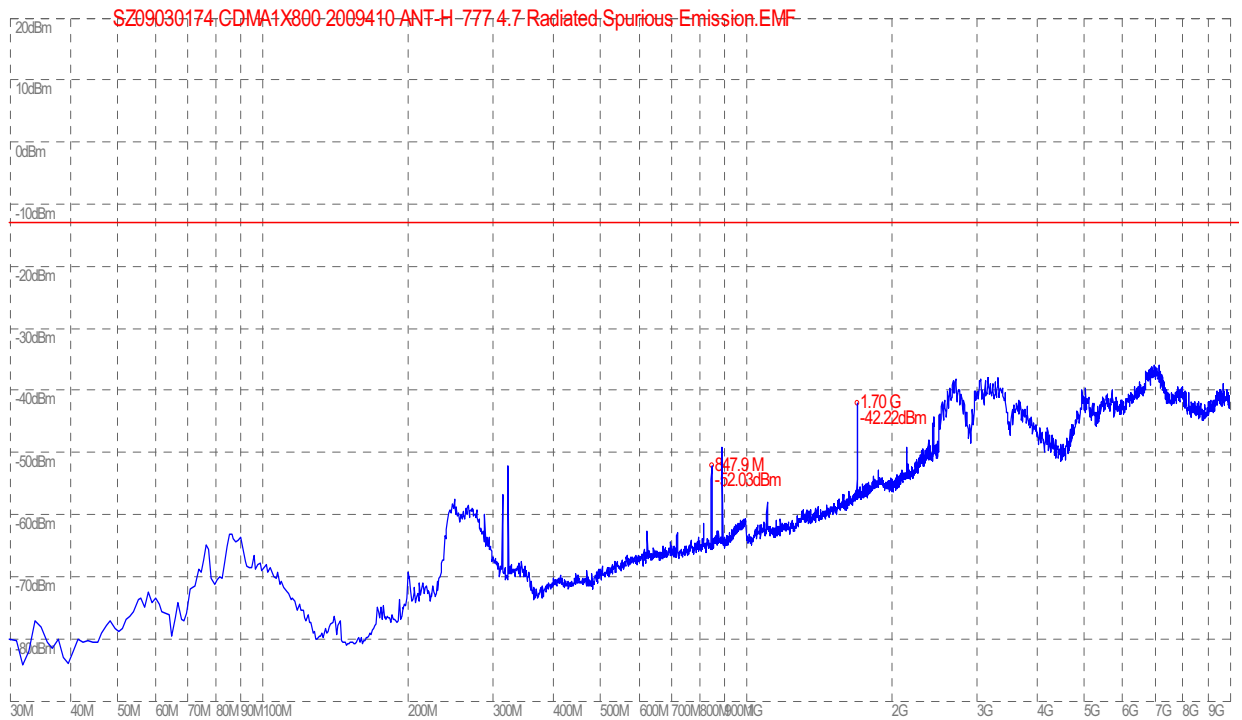

(Plot C.1: CDMA 800MHz Channel = 777, Test Antenna Horizontal)

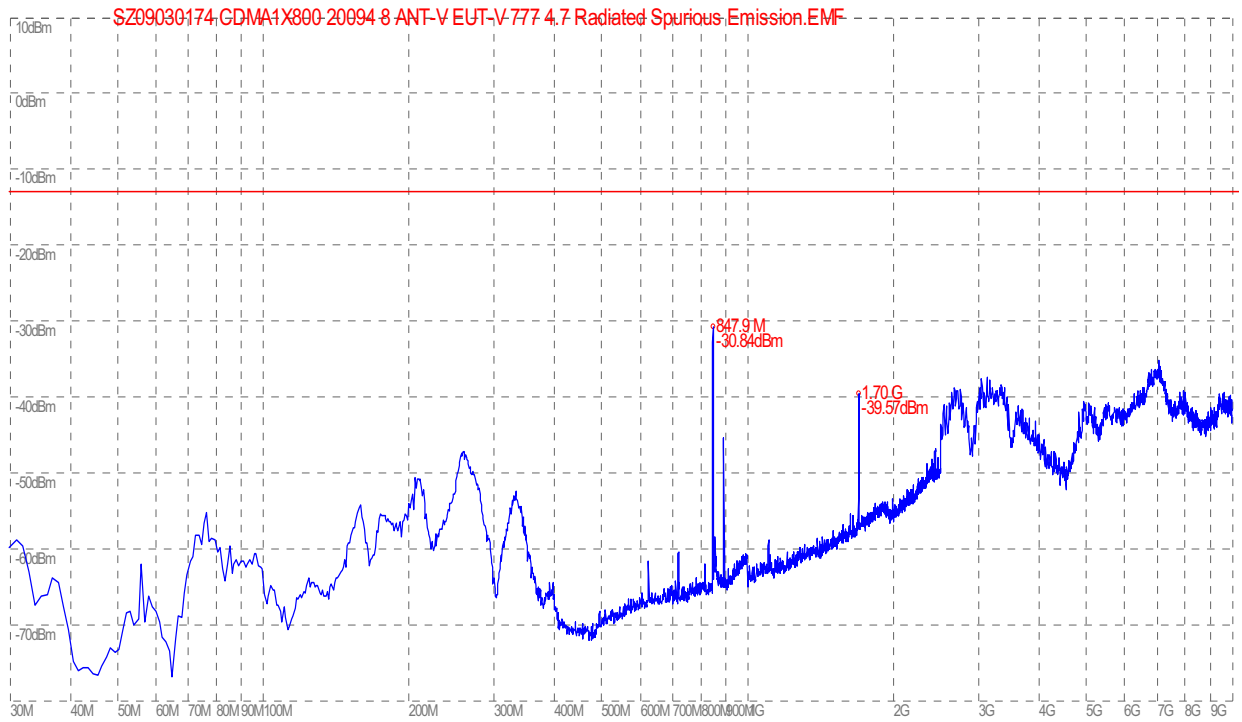

(Plot C.2: CDMA 800MHz Channel = 777, Test Antenna Vertical)

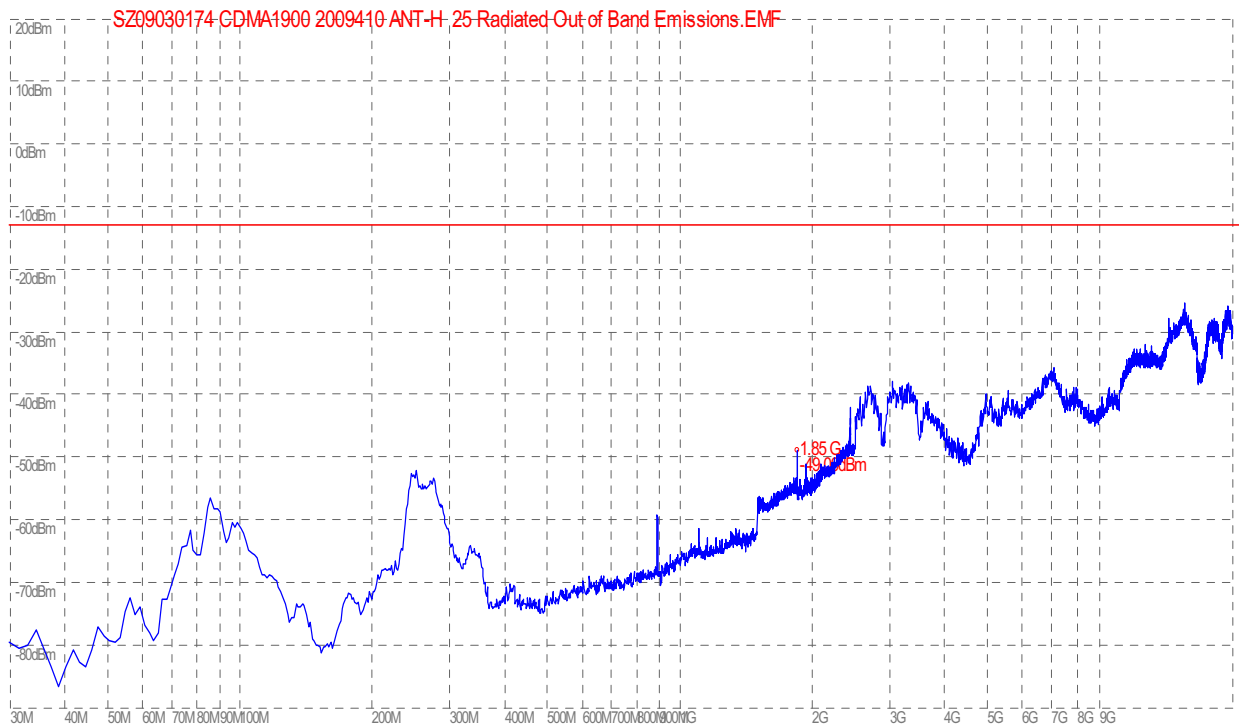

(Plot D.1: CDMA 1900MHz Channel = 25, Test Antenna Horizontal)

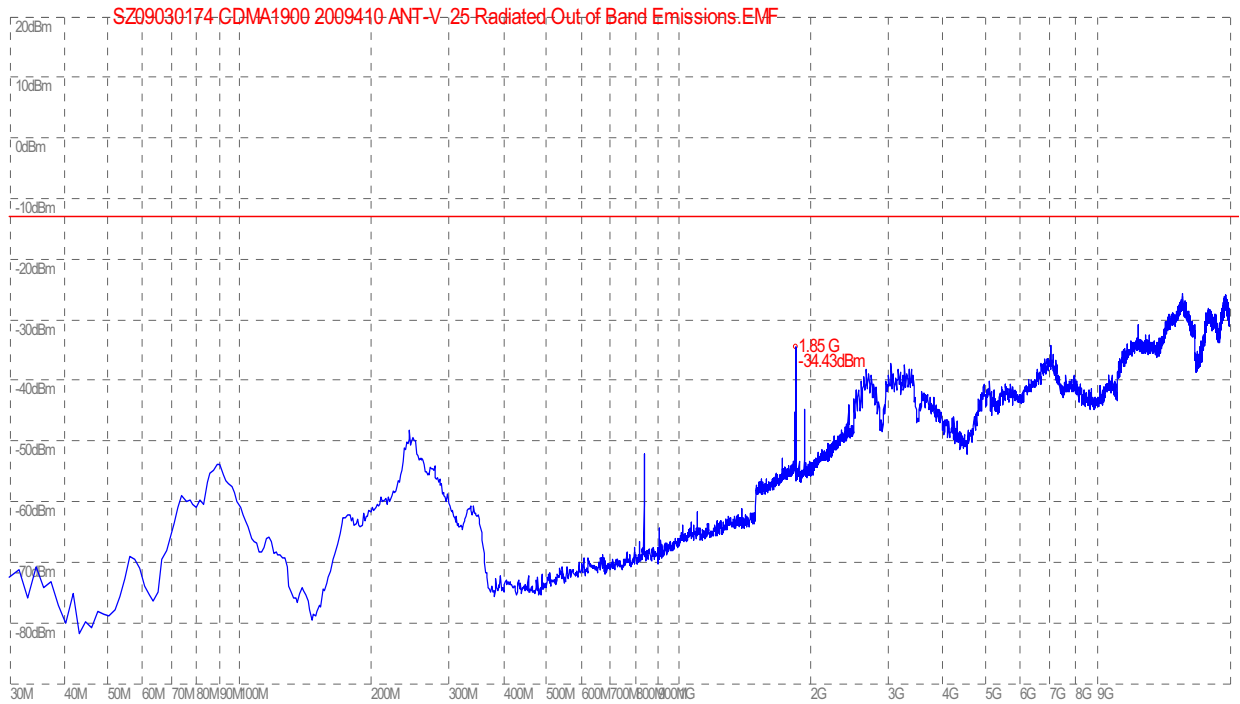

(Plot D.2: CDMA 1900MHz Channel = 25, Test Antenna Vertical)

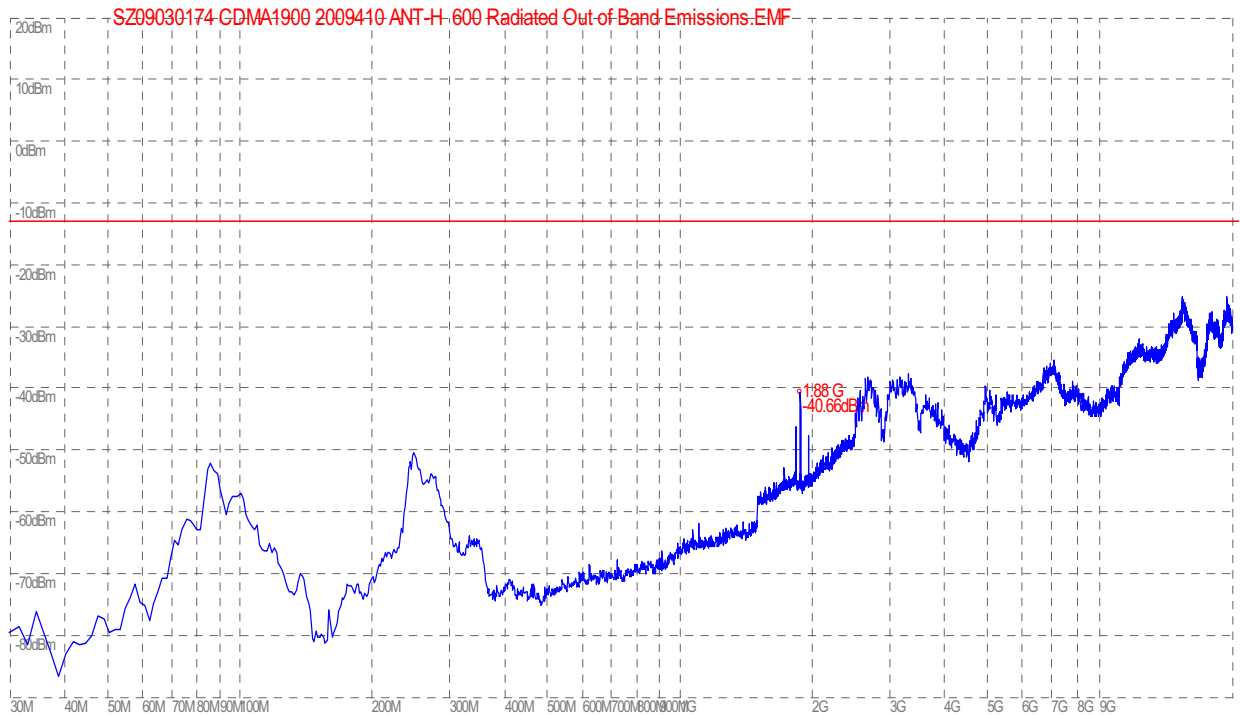

(Plot E.1: CDMA 1900MHz Channel = 600, Test Antenna Horizontal)

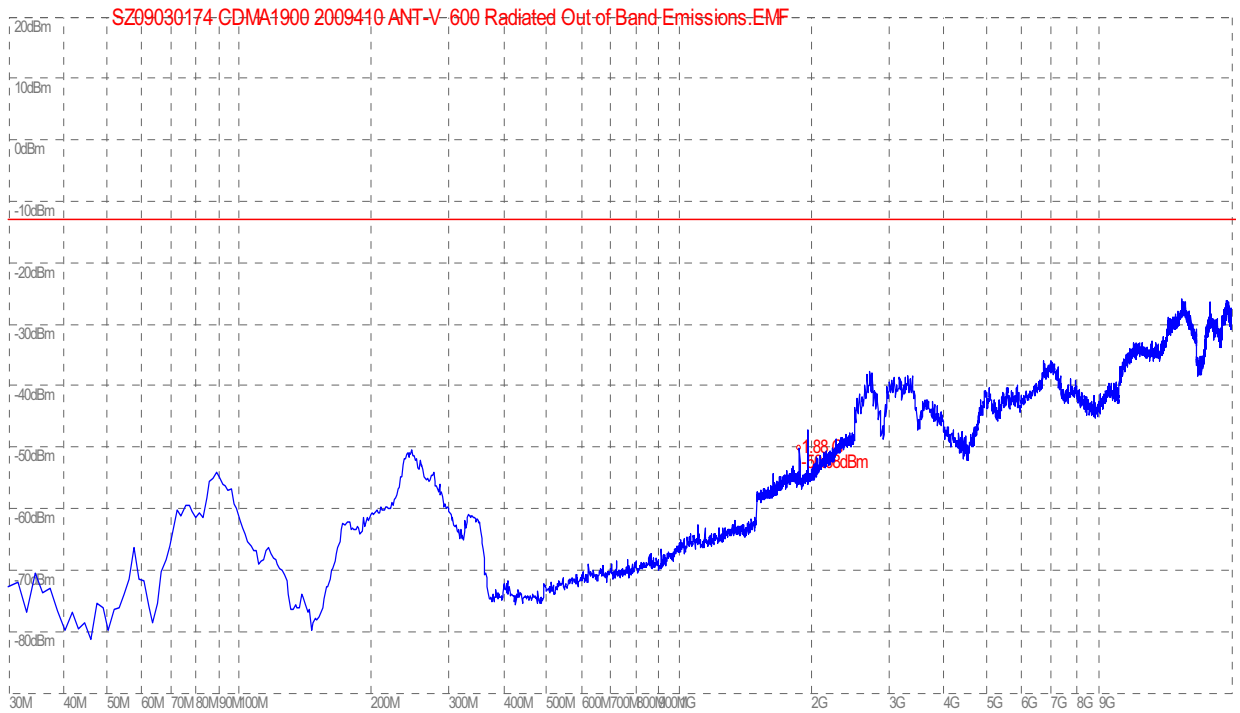

(Plot E.2: CDMA 1900MHz Channel = 600, Test Antenna Vertical)

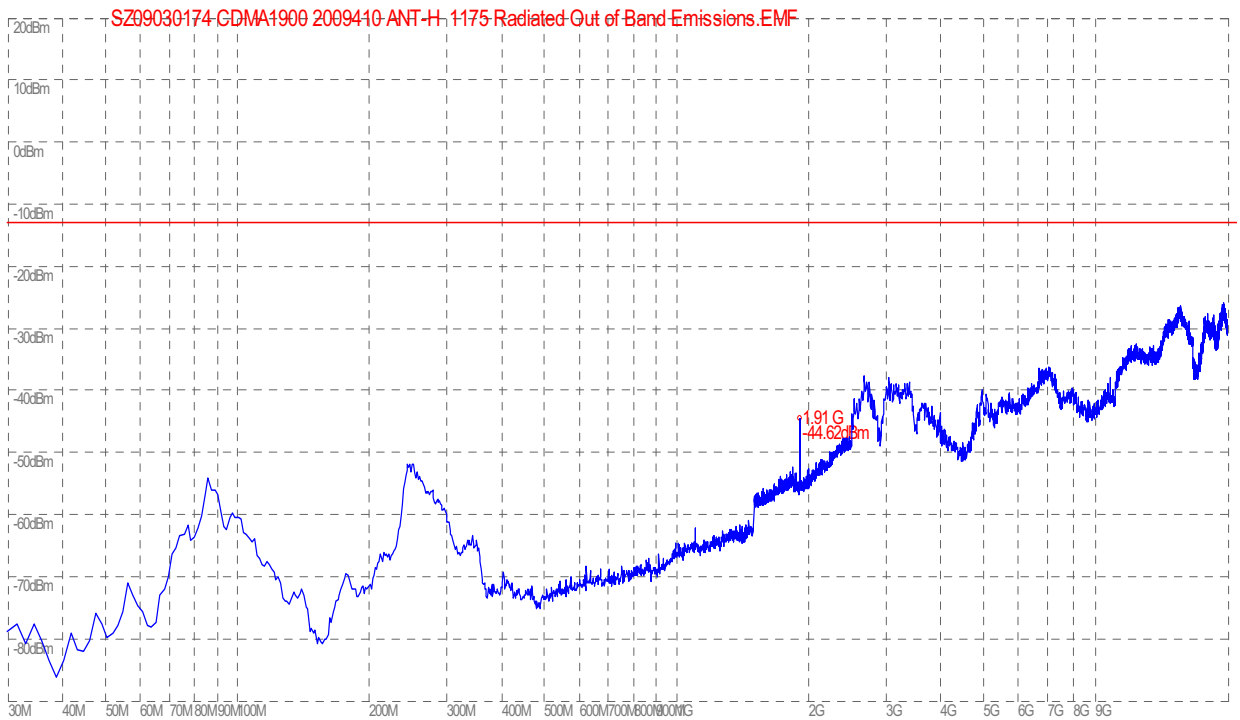

(Plot F.1: CDMA 1900MHz Channel = 1175, Test Antenna Horizontal)

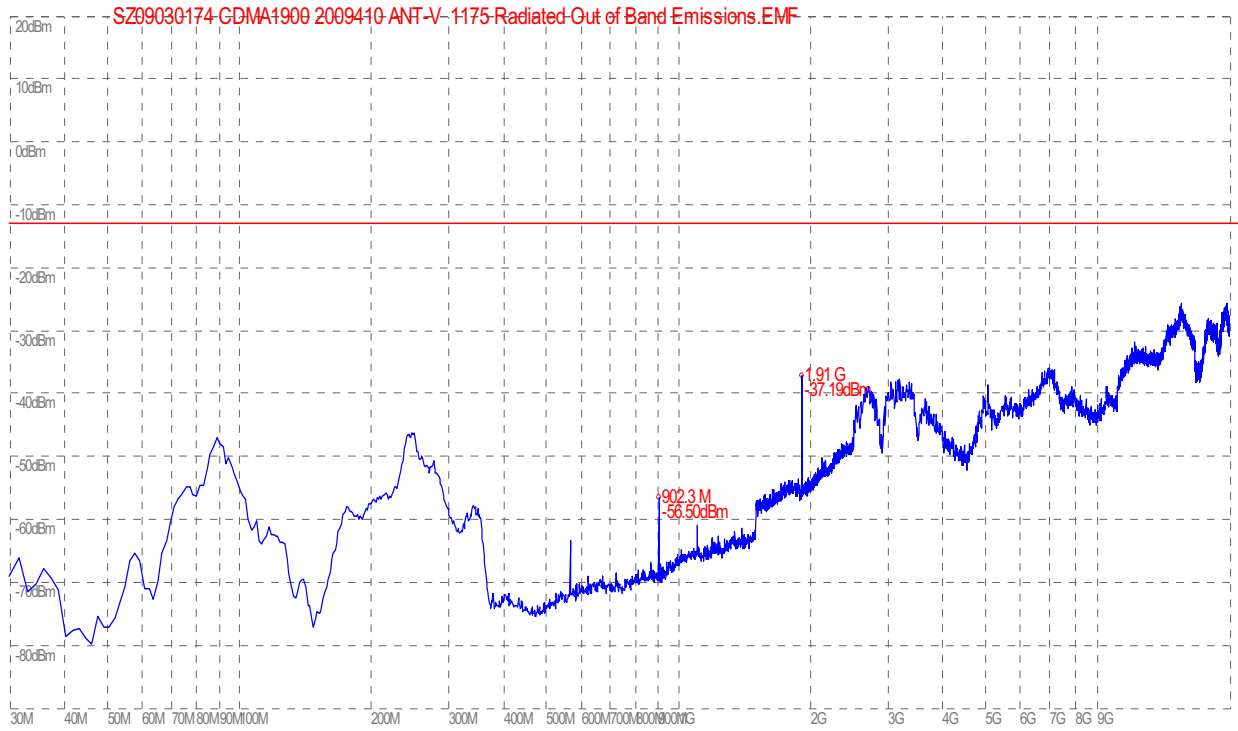

(Plot F.2: CDMA 1900MHz Channel = 1175, Test Antenna Vertical)

3.9 Frequency Stability

3.9.1 Requirement

According to FCC section 22.355 and section 24.235, the frequency stability shall be sufficient to ensure that the fundamental emission stays within the authorized frequency block. According to FCC section 2.1055, the test conditions are:

- (a) The temperature is varied from -30°C to $+50^{\circ}\text{C}$ at intervals of not more than 10°C .
- (b) For hand carried battery powered equipment, the primary supply voltage is reduced to the battery operating end point which shall be specified by the manufacture. The supply voltage shall be measured at the input to the cable normally provided with the equipment, or at the power supply terminals if cables are not normally provided.

3.9.2 Test Description

Test Setup:

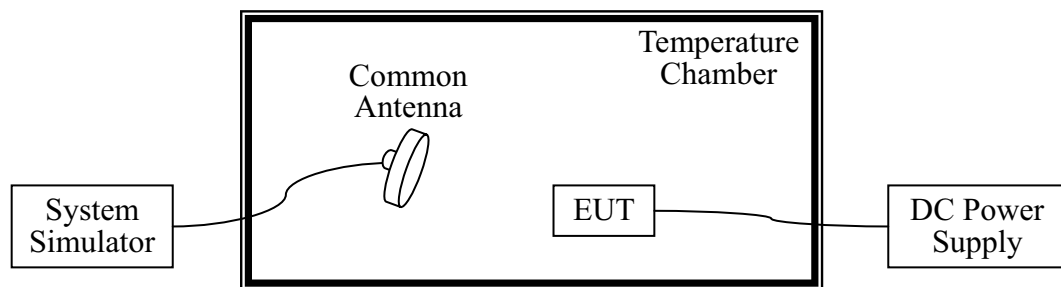

The EUT, which is powered by the DC Power Supply directly, is located in the Temperature Chamber. The EUT is commanded by the System Simulator (SS) to operate at the maximum output power. A call is established between the EUT and the SS via a Common Antenna.

Equipments List:

Description	Manufacturer	Model	Serial No.	Cal. Date	Cal. Due
System Simulator	Agilent	E5515C	GB43130131	2008.09	1year
DC Power Supply	Good Will	GPS-3030DD	EF920938	2008.08	2year
Temperature Chamber	YinHe Experimental Equip.	HL4003T	(n.a.)	2008.08	1year

3.9.3 Test Procedure

1. Perform test system setup as section 3.1.3.
2. Set the voltage of the DC Power Supply to normal supply voltage (here used 5.0V) and the

temperature of the Temperature Chamber to vary from -30°C to +50°C at intervals of 10°C.

3. At each temperature level, the EUT is powered off and kept in the Temperature Chamber for two hours. After sufficient stabilization, turn on the EUT, command it via the System Simulator (SS) to operate at the maximum output power i.e. A communication link is established between the EUT and the SS.
4. The low, middle and the high channels are selected to perform tests respectively.
5. The frequency deviation is measured (directly read from the SS, which can report the parameter) within three minutes.
6. Set the voltage of the DC Power Supply to high extreme supply voltage (here used 5.5V) and the temperature of the Temperature Chamber to normal (here used +22°C), then repeat step 3 to 8.
7. Set the voltage of the DC Power Supply to low extreme supply voltage (here used 4.5V) and the temperature of the Temperature Chamber to normal (here used +22°C), then repeat step 3 to 8.

3.9.4 Test Result

Band	Test Conditions		Frequency Deviation						Verdict
	Power (VDC)	Temperature (°C)	Channel = 1013 (824.7MHz)		Channel = 384 (836.52MHz)		Channel = 777 (848.31MHz)		
			Hz	Limits	Hz	Limits	Hz	Limits	
CDMA 800MHz	5.0	-30	-6.41	±2.5ppm	11.41	±2.5ppm	12.45	±2.5ppm	PASS
		-20	19.00		12.68		27.68		
		-10	11.00		10.61		18.58		
		0	2.59		-5.30		-1.36		
		+10	-2.42		1.46		-6.99		
		+20	-0.20		3.37		2.35		
		+30	15.01		24.59		17.32		
		+40	19.39		29.99		4.17		
		+50	20.36		-2.41		-9.68		
	5.5	+25	21.07	25.02	24.22				
	4.5	+25	15.52	18.38	7.51				



Band	Test Conditions		Frequency Deviation						Verdict
	Power (VDC)	Temperature (°C)	Channel = 25 (1851.2MHz)		Channel = 600 (1880.0MHz)		Channel = 1175 (1908.8MHz)		
			Hz	Limits	Hz	Limits	Hz	Limits	
CDMA 1900MHz	5.0	-30	22.00	±1ppm	26.11	±1ppm	12.49	±1ppm	PASS
		-20	23.35		26.62		-7.22		
		-10	32.37		-5.29		19.09		
		0	12.64		19.85		30.13		
		+10	-4.10		5.02		23.65		
		+20	17.01		30.72		14.68		
		+30	8.39		25.12		26.75		
		+40	31.04		-1.48		33.49		
		+50	15.15		-8.67		17.55		
	5.5	+25	23.47	21.35	16.18				
	4.5	+25	26.11	21.84	-4.59				

** END OF REPORT **