



47 CFR PART 15B, PART 22H, PART 24E

TEST REPORT

of

HG-M101

Model Name: HG-M101
Trade Name: Haier
Report No.: SZ07090047E01
FCC ID: SG7080117HG-M101

prepared for

Qingdao Haier Telecom Co., Ltd.

No.1, Haier Road, Hi-tech Zone, Qingdao, 266101, P.R.China

Shenzhen Morlab Communications Technology Co., Ltd.

3/F, Electronic Testing Building, Shao Road, Xili,

Nanshan District, Shenzhen, 518055 P. R. China

Tel: +86 755 86130398

Fax: +86 755 86130218



NOTE: This test report can be duplicated completely for the legal use with the approval of the applicant, it shall not be reproduced except in full, without the written approval of Shenzhen Morlab Communications Technology Co., Ltd. Any objections should be raised to us within thirty workdays since the date of issue.



TABLE OF CONTENTS

1.	TEST RESULT CERTIFICATION	4
2.	GENERAL INFORMATION	5
2.1	Equipment under Test (EUT) Description	5
2.2	Test Standards and Results	6
2.3	Facilities and Accreditations	7
2.3.1	Facilities	7
2.3.2	Test Equipments	7
2.3.3	Test Environment Conditions	8
3.	47 CFR PART 15B REQUIREMENTS	9
3.1	General Information.....	9
3.1.1	EUT Function and Test Mode	9
3.1.2	Test Setup	10
3.2	Conducted Emission	12
3.2.1	Requirement	12
3.2.2	Test Procedure	12
3.2.3	Test Result	13
3.3	Radiated Emission	15
3.3.1	Requirement	15
3.3.2	Test Procedure	15
3.3.3	Test Result	16
4.	47 CFR PART 2, PART 22H, PART 24E REQUIREMENTS	18
4.1	General Information.....	18
4.1.1	Conducted Related Tests	18
4.1.2	Radiated Power and Spurious Emission Tests	19
4.1.3	Frequency Stability Test.....	20
4.2	Frequencies.....	21
4.2.1	Frequency Blocks Available for Cellular Service	21
4.2.2	Frequency Blocks Available for Broadband PCS	21
4.2.3	Test Procedure	21
4.2.4	Test Result.....	22



4.3	Conducted RF Output Power	24
4.3.1	Requirement	24
4.3.2	Test Procedure	24
4.3.3	Test Result	25
4.4	Occupied Bandwidth	29
4.4.1	Occupied Bandwidth Definition	29
4.4.2	Test Procedure	29
4.4.3	Test Result	30
4.5	Conducted Spurious Emission	34
4.5.1	Requirement	34
4.5.2	Test Procedure	34
4.5.3	Test Result	35
4.6	Transmitter Radiated Power (EIRP/ERP)	45
4.6.1	Requirement	45
4.6.2	Test Procedure	45
4.6.3	Test Result	46
4.7	Radiated Spurious Emission	50
4.7.1	Requirement	50
4.7.2	Test Procedure	50
4.7.3	Test Result	51
4.8	Frequency Stability	53
4.8.1	Frequency Stability Requirement	53
4.8.2	Test Procedure	53
4.8.3	Test Result	54
I	PHOTOGRAPH OF THE TEST SETUP	55
II	PHOTOGRAPH OF THE EUT	57



1. Test Result Certification

Equipment under Test: HG-M101

Trade Name: Haier
Model Name: HG-M101
FCC ID: SG7080117HG-M101

Applicant: Qingdao Haier Telecom Co., Ltd.
No.1,Haier Road, Hi-tech Zone,Qingdao,266101,P.R.China
Manufacturer: Qingdao Haier Telecom Co., Ltd.
No.1,Haier Road, Hi-tech Zone,Qingdao,266101,P.R.China

Test Standards: 47 CFR Part 2
47 CFR Part 15 Subpart B
47 CFR Part 22 Subpart H
47 CFR Part 24 Subpart E

Test Result: PASS

*** We hereby certify that:**

The equipment under test was tested by Shenzhen Morlab Communications Technology Co., Ltd. The test data, data evaluation, test procedures and equipment configurations shown in this report were made in accordance with the requirement of related FCC rules.

The test results of this report only apply for the tested sample equipment identified above. The test report shall be invalid without all the signatures of the test engineer, the reviewer and the approver.

Tested by: Luo Biao Dated: 2008.07.22
Luo Biao

Reviewed by: Yao Xiaofeng Dated: 2008.01.23
Yao Xiaofeng

Approved by: Shu Luan Dated: 2008.01.23
Shu Luan



2. General Information

2.1 Equipment under Test (EUT) Description

Description: HG-M101
Model Name: HG-M101
Serial No.....: N/A
IMEI: 356817017620516
Hardware Version: P1
Software Version: M101—H01—S002—SPANISH
Emission Designator.....: 300KGXW
Modulation: GMSK
Frequency: GSM850, Tx: 824.20 - 848.80MHz
Rx: 869.20 - 893.80MHz
PCS1900, Tx: 1850.20 - 1909.80MHz
Rx: 1930.20 - 1989.80MHz
Power.....: 2Watt for GSM850; 1 Watt for PCS1900
Power Supply:: Battery
Brand name: Haier
Model Name: H11102
Capacitance: 650mAh
Rated voltage: 3.7V
Charge limited: 4.249V
Manufacturer: Qingdao Haier Telecom Co., Ltd.
Accessory Equipment:..... AC Adapter (Charger for Battery)
Brand Name: Haier
Model Name: LSA-80A9
Rated Input: ~ 100V-240V, 0.2A, 2W, 50/60Hz
Rated Output: = 5V, 0.55A, 2.75W
Manufacturer: Qingdao Haier Telecom Co., Ltd.
Wire Length: 140cm

NOTE:

1. The EUT is Tri-band GSM Mobile Phone, the Cellular 850MHz band and the PCS1900MHz band were tested in this report.
2. The normal configuration for the EUT is the Mobile Phone (MS) associated with ancillary equipments e.g. the Battery and/or the AC Adapter (Charger).
3. The normal, high and low voltage supply for the Battery of the EUT is separately 3.7V, 4.2V and 3.6V, which are specified by the applicant.
4. For detailed features about the EUT, please see user manual supplied by the applicant.



2.2 Test Standards and Results

The objective of the report is to perform tests according to 47 CFR Part 2, Part 15, Part 22, Part 24 for FCC ID Certification:

No.	Identity	Document Title
1	47 CFR Part 2 (10-1-05 Edition)	Frequency Allocations and Radio Treaty Matters; General Rules and Regulations
2	47 CFR Part 15 (10-1-05 Edition)	Radio Frequency Devices
3	47 CFR Part 22 (10-1-05 Edition)	Public Mobile Services
4	47 CFR Part 24 (10-1-05 Edition)	Personal Communications Services

Test detailed items and the results are as below:

No.	Rules	Test Type	Result	Date of Test
1	§15.107	Conducted Emission	PASS	2008-1-8
2	§15.109	Radiated Emission	PASS	2008-1-8
3	§2.106 §22.905 §24.229	Frequencies	PASS	2008-1-11
4	§2.1046	Conducted RF Output Power at Antenna Terminal	PASS	2008-1-11
5	§2.1049	Occupied Bandwidth	PASS	2008-1-11
6	§2.1051 §2.1057 §22.917 §24.238	Conducted Spurious Emission at Antenna Terminal	PASS	2008-1-11
7	§22.913 §24.232	Transmitter Radiated Power (EIPR/ERP)	PASS	2008-1-11
8	§2.1053 §2.1057 §22.917 §24.238	Radiated Spurious Emission	PASS	2008-1-11
9	§2.1055 §22.355 §24.235	Frequency Stability	PASS	2008-1-11

2.3 Facilities and Accreditations

2.3.1 Facilities

Shenzhen Electronic Product Quality Testing Center Morlab Laboratory is a testing organization accredited by China National Accreditation Service for Conformity Assessment (CNAS) according to ISO/IEC 17025. The accreditation certificate number is CNAS L1659.

All measurement facilities used to collect the measurement data are located at Electronic Testing Building, Shahe Road, Xili, Nanshan District, Shenzhen, P. R. China. The site was constructed in conformance with the requirements of ANSI C63.7, ANSI C63.4 and CISPR Publication 22, the FCC registration number is 741109.

2.3.2 Test Equipments

No.	Description	Specification
1	System Simulator	Manufacturer: Rohde&Schwarz Model No.: CMU200 Serial No.: 100448
2	System Simulator	Manufacturer: Agilent Model No.: E5515C Serial No.: GB43130131
3	Spectrum Analyzer	Manufacturer: Agilent Model No.: E7405A Serial No.: US44210471
4	Telecommunication Antenna	Manufacturer: European Antennas Model No.: PSA-45010R/356 Serial No.: 403688-001
5	Trilogy Antenna	Manufacturer: Schwarzbeck Model No.: VULB 9163 Serial No.: 9163-274
6	Horn Antenna	Manufacturer: Schwarzbeck Model No.: BBHA 9120C Serial No.: 9120C-384
7	Power Splitter	Manufacturer: WEINSCHEL Model No.: 1506A Serial No.: NW521
8	Anechoic Chamber	Manufacturer: Albatross Projects GmbH
9	DC Power Supply	Manufacturer: Good Will Instrument Co., Ltd.
10	Temperature Chamber	Manufacturer: Chongqing YinHe Experimental Equip. Co., Ltd.

NOTE:

1. Equipments listed above have been calibrated and are in the period of validation.

2.3.3 Test Environment Conditions

During the measurement, the environmental conditions were within the listed ranges:

Temperature:	20 - 35°C
Relative Humidity:	40 - 60%
Atmospheric Pressure:	86-106kPa

3. 47 CFR Part 15B Requirements

3.1 General Information

3.1.1 EUT Function and Test Mode

The test modes of the EUT are showed as below:

(1): Call Mode:

The EUT configuration of the emission tests was MS + Battery + Charger.

Before the measurement, the lithium battery was completely discharge.

During the measurement, the lithium battery was installed into the MS, and the charger was connected to the MS. A communication link was established between the MS and a System Simulator (SS). The MS operated at mid ARFCN and maximum output power (level 5 for GSM 850 MHz and level 0 for PCS 1900 MHz).

(2): Idle Mode:

The EUT configuration of the emission tests was MS + Battery + Charger.

The EUT was synchronized to the BCCH, listening to the CCCH and able to respond to paging message. Periodic location updating was disabled.

NOTE:

1. All test modes are performed, only the worst cases are recorded in this report.

3.1.2 Test Setup

3.1.2.1 Conducted Emission Test

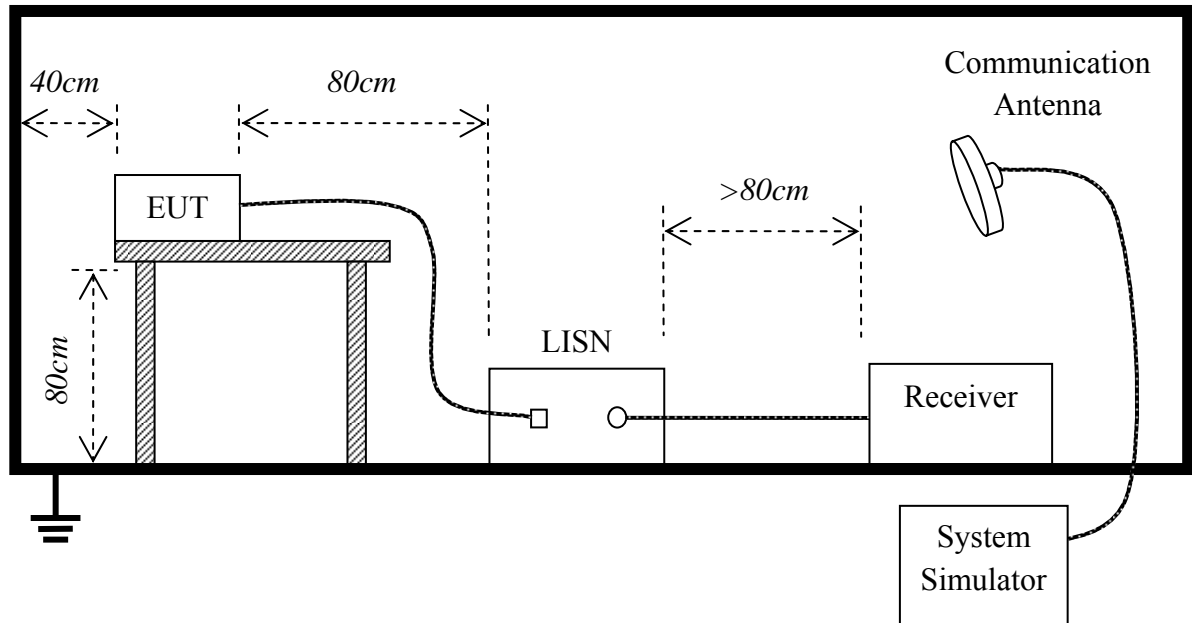

1. The test is performed in a Shield Room; the factors of the test system are calibrated to correct the reading.
2. The EUT is placed on a 0.8 meters high insulating table and keeps 0.4 meters away from the conducting wall of the Shield Room.
3. The EUT is connected to the power mains through a Line Impedance Stabilization Network (LISN). The LISN provides $50\Omega/50\mu\text{H}$ of coupling impedance for the measuring instrument.

3.1.2.2 Radiated Emission Test

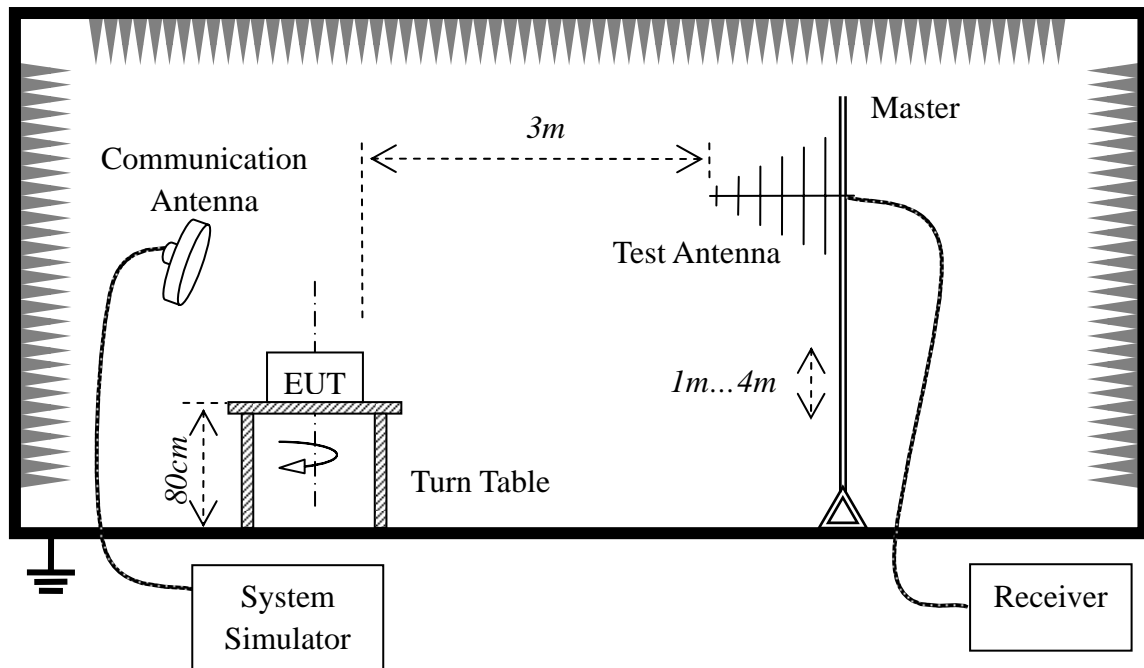

1. The test is performed in a Semi-anechoic Chamber; the factors of the test system are calibrated to correct the reading.
2. The EUT is placed on a 0.8 meters high insulating table and keeps 3 meters away from the Test Antenna, which is mounted on the top of a variable-height antenna Master tower.

NOTE:

1. The test method is the substitution method according to TIA-603-C.

3.2 Conducted Emission

3.2.1 Requirement

According to FCC §15.107, the radio frequency voltage that is conducted back onto the AC power line on any frequency within the band 150kHz to 30MHz shall not exceed the limits in the following table, as measured using a 50 μ H/50 Ω line impedance stabilization network (LISN).

Frequency range (MHz)	Conducted Limit (dB μ V)	
	Quasi-peak	Average
0.15 - 0.50	66 to 56	56 to 46
0.50 - 5	56	46
0.50 - 30	60	50

NOTE:

1. The limit subjects to the Class B digital device.
2. The lower limit shall apply at the band edges.
3. The limit decreases linearly with the logarithm of the frequency in the range 0.15MHz to 0.50MHz.

3.2.2 Test Procedure

1. Perform test setup as described in section 3.1.2.1.
2. Each test mode in section 3.1.1 should be applied. At each test mode, the frequency range from 150 kHz to 30MHz is searched using the CISPR Quasi-Peak and/or the Average detector of the Receiver. If the emission levels measured with Quasi-Peak detector are lower than the Average Limit, it's not necessary to measure with Average detector.
3. The emission levels at both L phase and N phase should be tested.
4. Record the test result plot and distinct points.
5. In the test report show the worst test data.

3.2.3 Test Result

A. Test Verdict Recorded for Suspicious Points:

No.	@Frequency (MHz)	Measured Emission Level (dB μ V)				Limit (dB μ V)		Verdict
		PK	QP	AV	Phase	QP	AV	
1	0.408	45.1	38.4	30.1	L	57.7	47.7	PASS
2	0.482	37.7	29.8	22.7	L	56.3	46.3	PASS
3	0.614	45.4	43.2	32.5	L	56.0	46.0	PASS
4	0.715	46.3	41.3	30.2	L	56.0	46.0	PASS
5	3.194	41.7	34.4	24.7	L	56.0	46.0	PASS
6	(n.a.)	(n.a.)	(n.a.)	(n.a.)	L	(n.a.)	(n.a.)	(n.a.)
7	0.611	47.2	43.8	35.5	N	56.0	46.0	PASS
8	0.713	44.6	40.7	32.3	N	56.0	46.0	PASS
9	2.595	43.1	36.7	27.2	N	56.0	46.0	PASS
10	2.897	46.3	38.6	29.1	N	56.0	46.0	PASS
11	3.080	46.9	39.6	29.0	N	56.0	46.0	PASS

B. Test Plot:

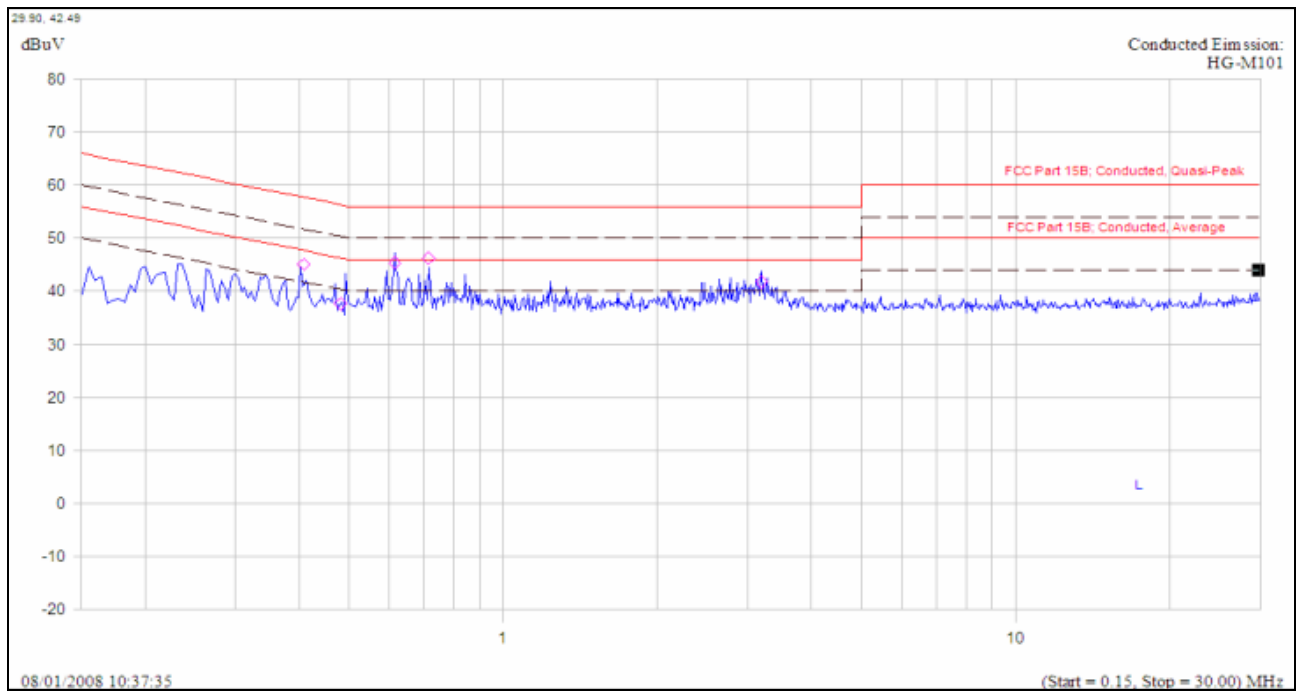

(Plot A: L Phase)

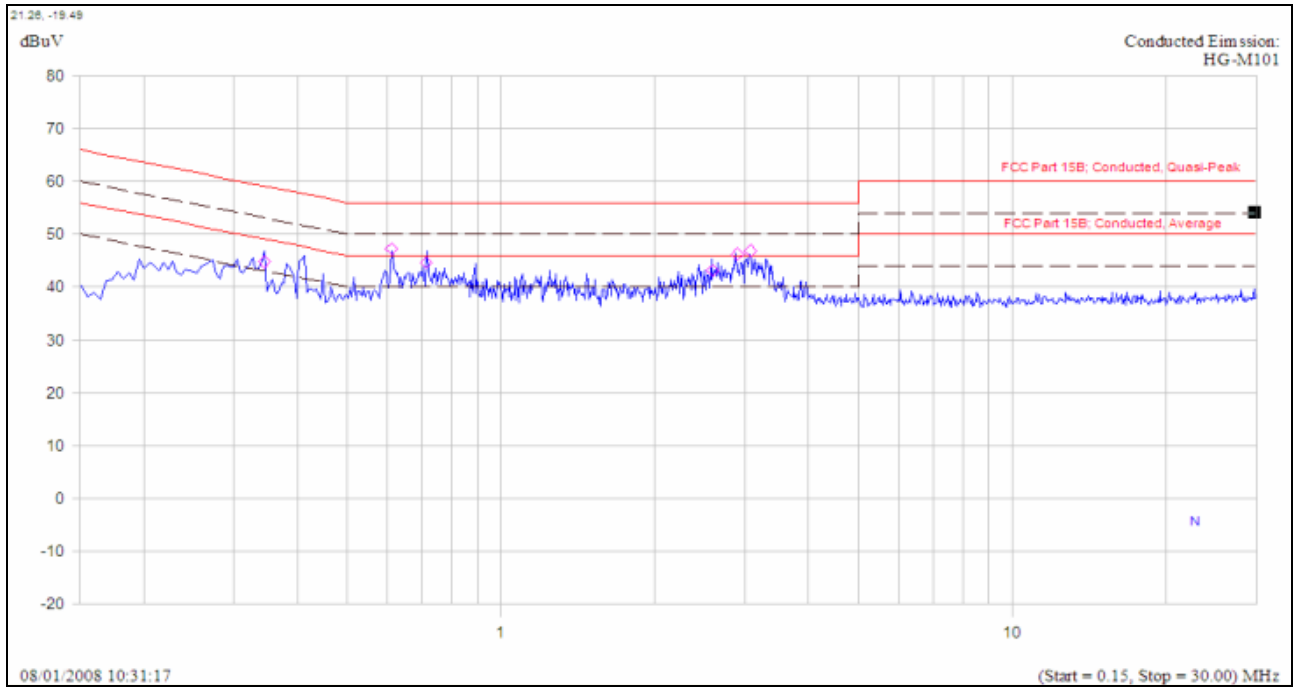

(Plot B: N Phase)

3.3 Radiated Emission

3.3.1 Requirement

According to FCC §15.109, the field strength of radiated emissions from unintentional radiators at a distance of 3 meters shall not exceed the following values:

Frequency range (MHz)	Field Strength	
	$\mu\text{V/m}$	$\text{dB}\mu\text{V/m}$
30 - 88	100	40
88 - 216	150	43.5
216 - 960	200	46
Above 960	500	54

NOTE:

1. Field Strength ($\text{dB}\mu\text{V/m}$) = $20 \cdot \log$ [Field Strength ($\mu\text{V/m}$)].
2. In the emission tables above, the tighter limit applies at the band edges.

3.3.2 Test Procedure

1. Perform test setup as described in section 3.1.2.2.
2. Each test mode in section 3.1.1 should be applied. At each test mode, the Turn Table turns from 0 degrees to 360 degrees to find the maximum reading; for the suspected points, the Test Antenna varies from 1 meter to 4 meters to determine the maximum value of the field strength.
3. The Receiver is set to Peak Detector function and specified bandwidth with maximum hold mode. If the emission level of the EUT in peak mode is 6dB lower than the limit specified, then testing could be stopped and the peak values would be reported; otherwise the emission less than 6dB margins would be retested one by one using the quasi-peak method.
4. The emission levels at both horizontal and vertical polarizations should be tested.
5. Record the test result plot and distinct points.
6. In the test report show the worst test data.

3.3.3 Test Result

A. Test Verdict Recorded for Suspicious Points:

No.	@Frequency (MHz)	Emission Level (dB μ V/m)			Quasi-Peak Limit (dB μ V/m)	Result
		PK	QP	Antenna Polarization		
1	133.195	23.9	----	Vertical	43.5	PASS
2	175.074	31.4	----	Vertical	43.5	PASS
3	243.254	27.3	----	Vertical	46.0	PASS
4	453.638	33.2	----	Vertical	46.0	PASS
5	524.740	38.7	----	Vertical	46.0	PASS
6	(n.a.)	(n.a.)	(n.a.)	Vertical	(n.a.)	(n.a.)
7	133.192	27.3	----	Horizontal	43.5	PASS
8	175.074	28.6	----	Horizontal	43.5	PASS
9	453.638	33.4	----	Horizontal	46.0	PASS
10	522.792	38.3	----	Horizontal	46.0	PASS
11	625.062	38.1	----	Horizontal	46.0	PASS

B. Test Plot:

Following is the plots for emission measurement; please note that marked spikes with circle should be ignored because they are MS and SS carrier frequency.

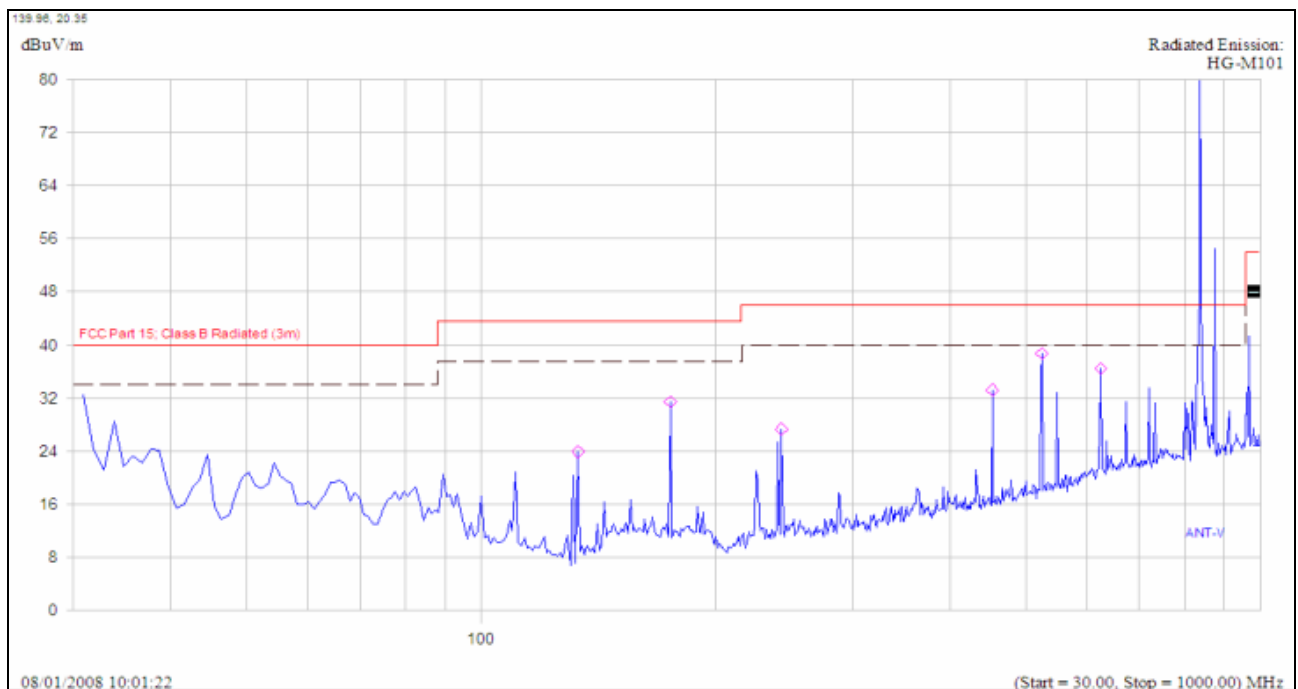

(Plot A: Test Antenna Vertical)

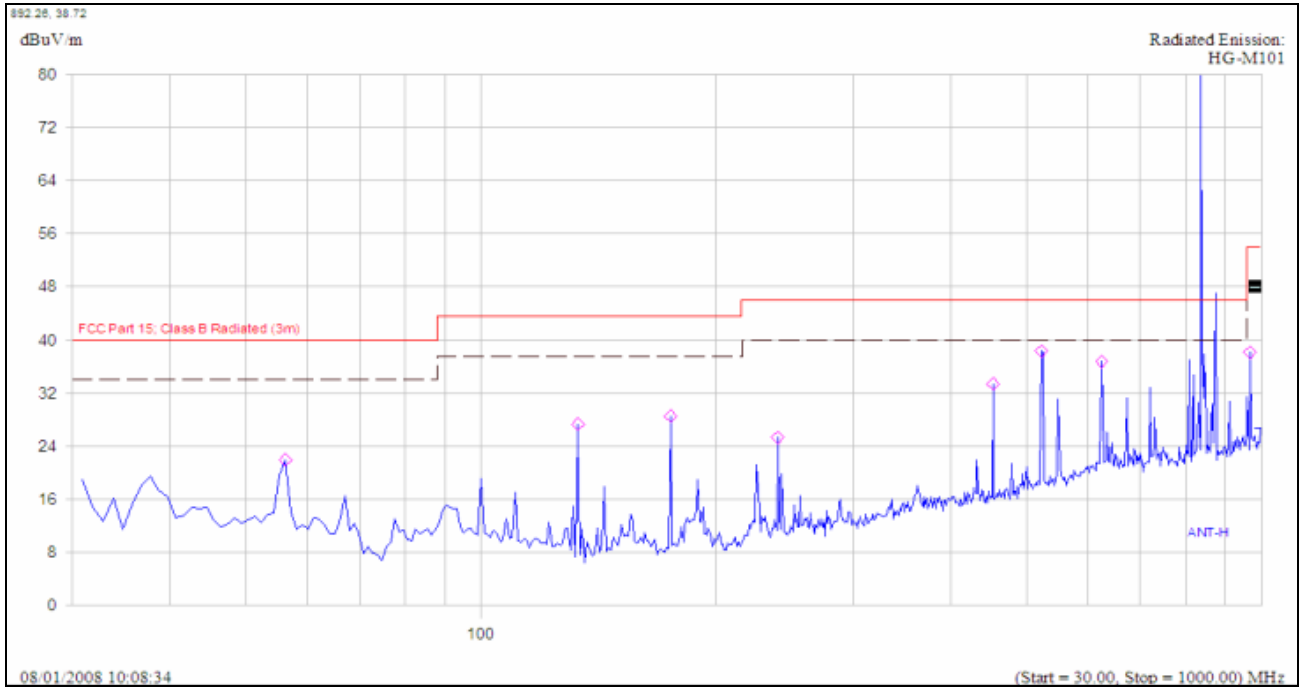

(Plot B: Test Antenna Horizontal)

4. 47 CFR Part 2, Part 22H, Part 24E Requirements

4.1 General Information

4.1.1 Conducted Related Tests

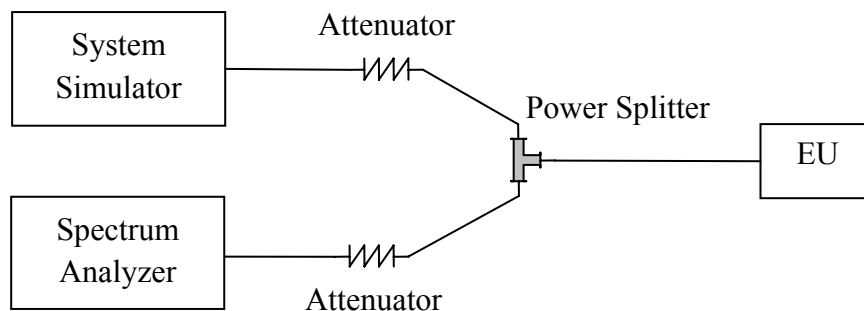

1. The EUT is coupled to the Spectrum Analyzer and the System Simulator with the suitable Attenuators through the Power Splitter; the path loss is calibrated to correct the reading.
2. The EUT is configured here as MS + Battery.
3. The EUT is commanded via the System Simulator (SS) to operate at the maximum output power i.e. Power Control Level (PCL) = 5 and Power Class = 4 for GSM 850MHz, Power Control Level (PCL) = 0 and Power Class = 1 for PCS 1900MHz.
4. The BCCH number of the SS used here is 200 for GSM 850MHz (520 for PCS 1900MHz). A communication link is established between the EUT and the SS.
5. The Spectrum Analyzer is set to max-peak detector function and maximum hold mode.

4.1.2 Radiated Power and Spurious Emission Tests

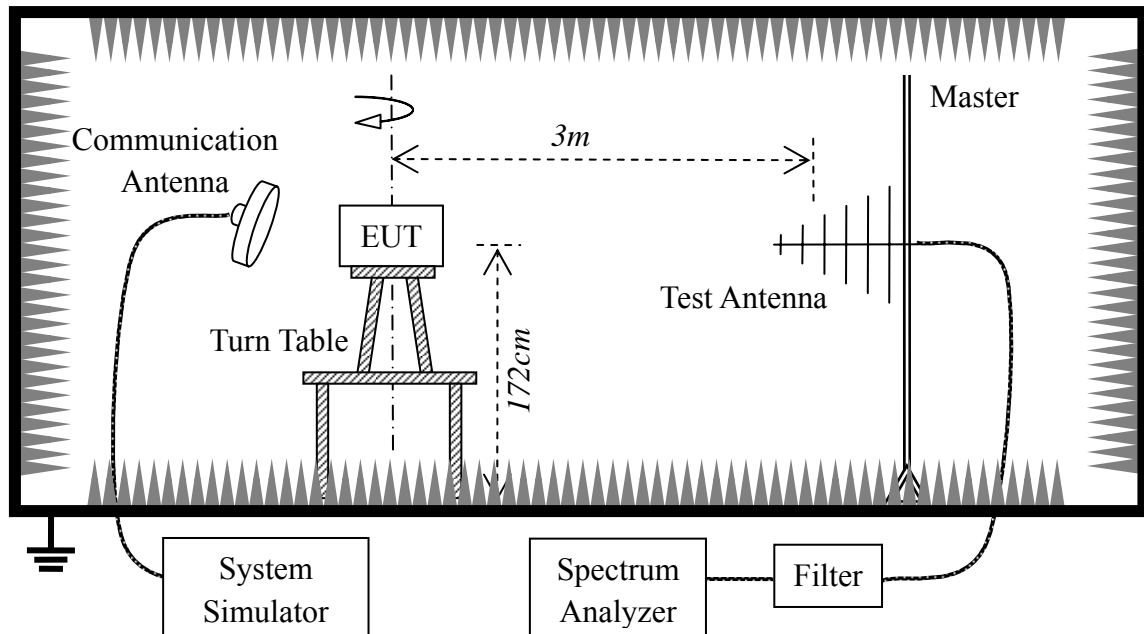

1. The test is performed in a full-Anechoic Chamber; the air loss of the site and the factors of the test system are pre-calibrated using the substitution method.
2. The EUT is configured as MS + Battery.
3. The EUT is placed on the vertical axis of a Turn Table 1.72 meters above the ground.
4. The Test Antenna is a bi-log one or a horn one, and the Test Antenna is at the same height as the EUT.
5. The EUT is commanded via the System Simulator (SS) to operate at the maximum output power i.e. Power Control Level (PCL) = 5 and Power Class = 4 for GSM 850MHz, Power Control Level (PCL) = 0 and Power Class = 1 for PCS 1900MHz.
6. The BCCH number of the SS used here is 200 for GSM 850MHz (520 for PCS 1900MHz). A communication link is established between the EUT and the SS.
7. The Spectrum Analyzer is set to max-peak detector function and maximum hold mode.

4.1.3 Frequency Stability Test

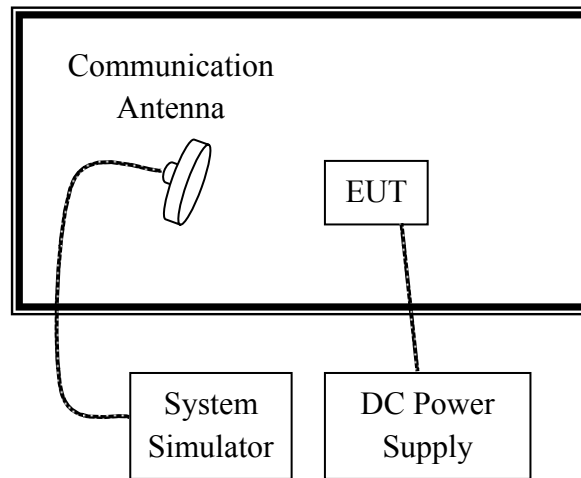

1. The test is performed in a Temperature Chamber.
2. The EUT is configured as MS + DC Power Supply.
3. The BCCH number of the SS used here is 200 for GSM 850MHz (520 for PCS 1900MHz).

4.2 Frequencies

4.2.1 Frequency Blocks Available for Cellular Service

According to FCC §22.905, the frequencies blocks assignment for the Cellular Radiotelephone Service are listed as below.

- (a) Channel Block A:
 - Mobile 824 - 835MHz, Base 869 - 880MHz;
 - Mobile 845 - 846.5MHz, Base 890 - 891.5MHz
- (b) Channel Block B:
 - Mobile 835 - 845 MHz, Base 880 - 890MHz;
 - Mobile 846.5 - 849 MHz, Base 891.5 - 894MHz

4.2.2 Frequency Blocks Available for Broadband PCS

According to FCC §24.229, the frequencies available in the Broadband PCS services are listed as below, in accordance with the frequency allocations table of FCC §2.106.

- (a) The following frequency blocks are available for assignment on an MTA basis:
 - Block A: 1850 - 1865MHz paired with 1930 - 1945MHz;
 - Block B: 1870 - 1885MHz paired with 1950 - 1965MHz.
- (b) The following frequency blocks are available for assignment on an BTA basis:
 - Block C: 1895 - 1910 MHz paired with 1975 - 1990MHz;
 - Block D: 1865 - 1870 MHz paired with 1945 - 1950MHz;
 - Block E: 1885 - 1890 MHz paired with 1965 - 1970MHz;
 - Block F: 1890 - 1895 MHz paired with 1970 - 1975MHz.

4.2.3 Test Procedure

1. Perform test system setup as section 4.1.1.
2. Perform test configuration as section 4.
3. The resolution bandwidth (RBW) of the Spectrum Analyzer was set to at least 1% of the emission bandwidth of the fundamental emission of the transmitter, e.g. for GSM modulated signal (here used): RBW=VBW=3kHz, for CDMA modulated signal: RBW=VBW=30kHz.
4. The lowest and the highest channel were selected to perform tests respectively. Set the TCH number to 128(low) and 251(high) for GSM 850MHz; TCH number to 512(low) and 810(high) for PCS 1900MHz.
5. Set the Spectrum Analyzer suitably to capture the waveform, search peak and mark, and then record the plot.

4.2.4 Test Result

The transmitter (Tx) frequency arrangement of the Cellular 850MHz band is represented with a formula $F(n) = 824.2 + 0.2 * (n - 128)$, $128 \leq n \leq 251$. The frequencies of the lowest channel and the highest channel are listed as follows.

1. Plot when the TCH number set to 128:

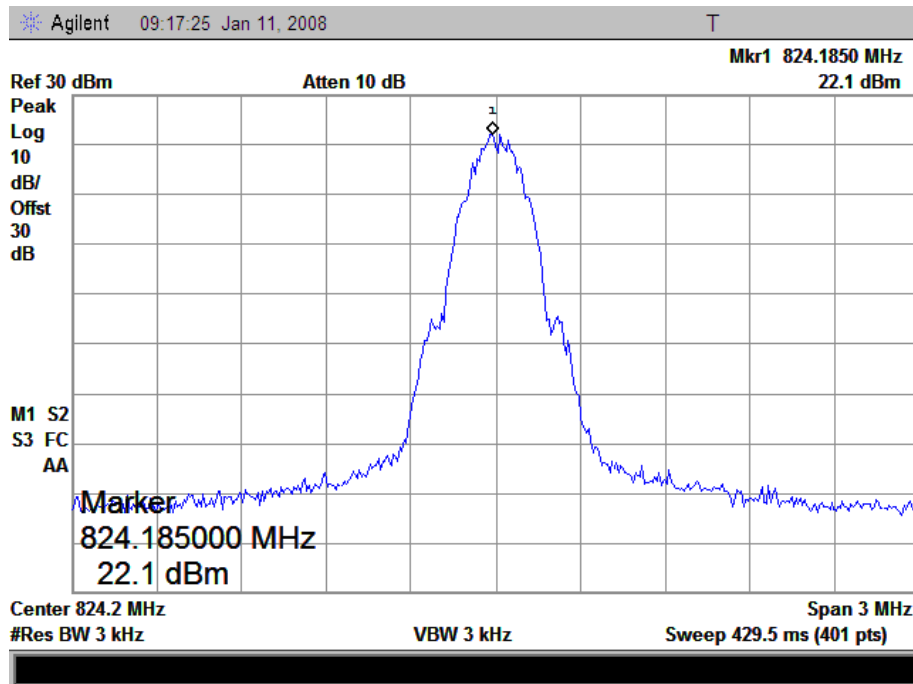

2. Plot when the TCH number set to 251:

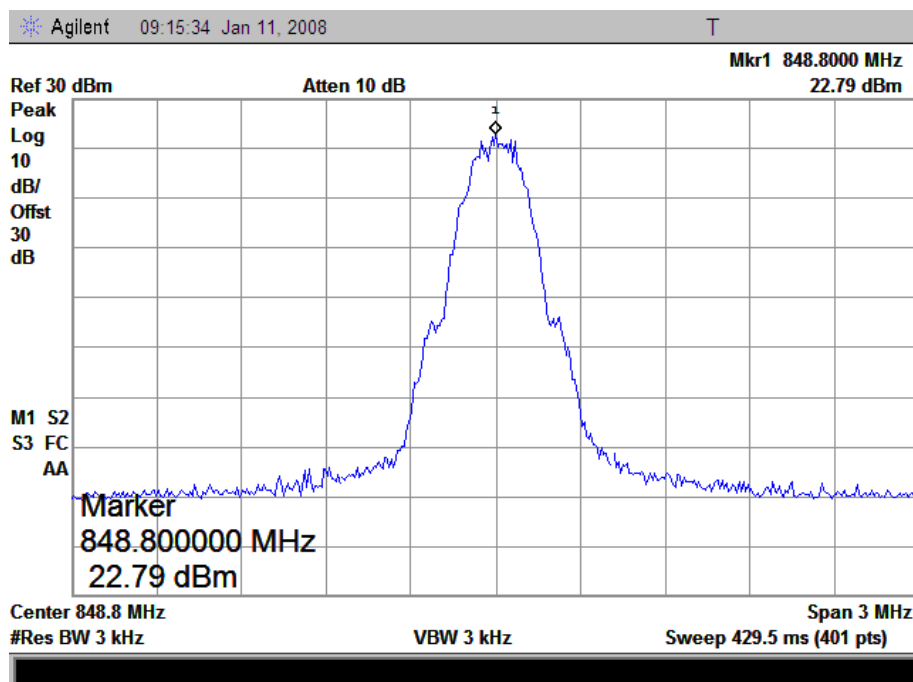

The transmitter (Tx) frequency arrangement of the PCS 1900MHz band is represented with a formula $F(n)=1850.2+0.2*(n-512)$, $512 \leq n \leq 810$. The frequencies of the lowest channel and the highest channel are listed as follows.

1. Plot when the TCH number set to 512:

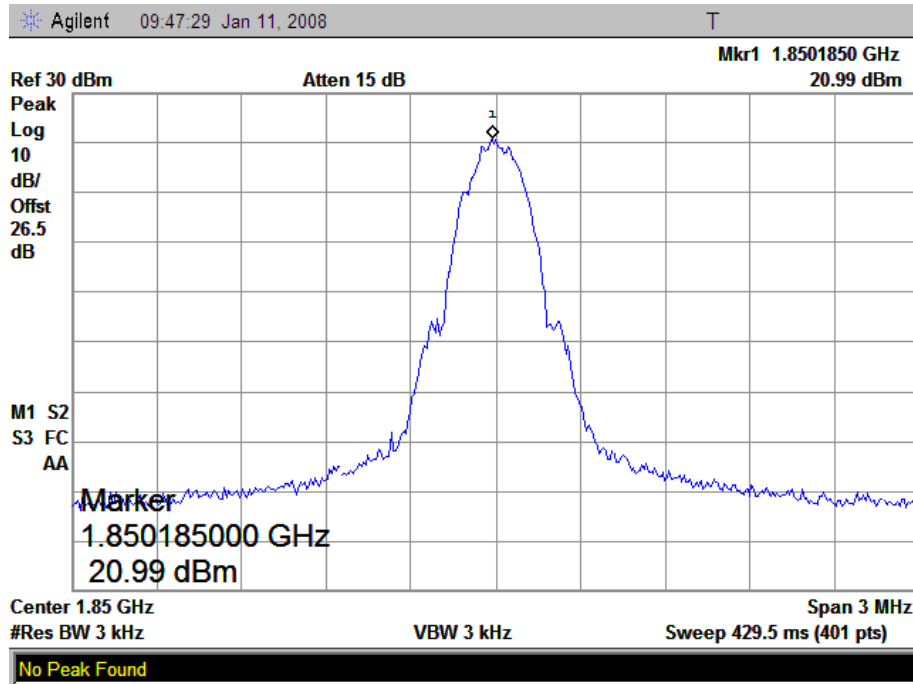

2. Plot when the TCH number set to 810:

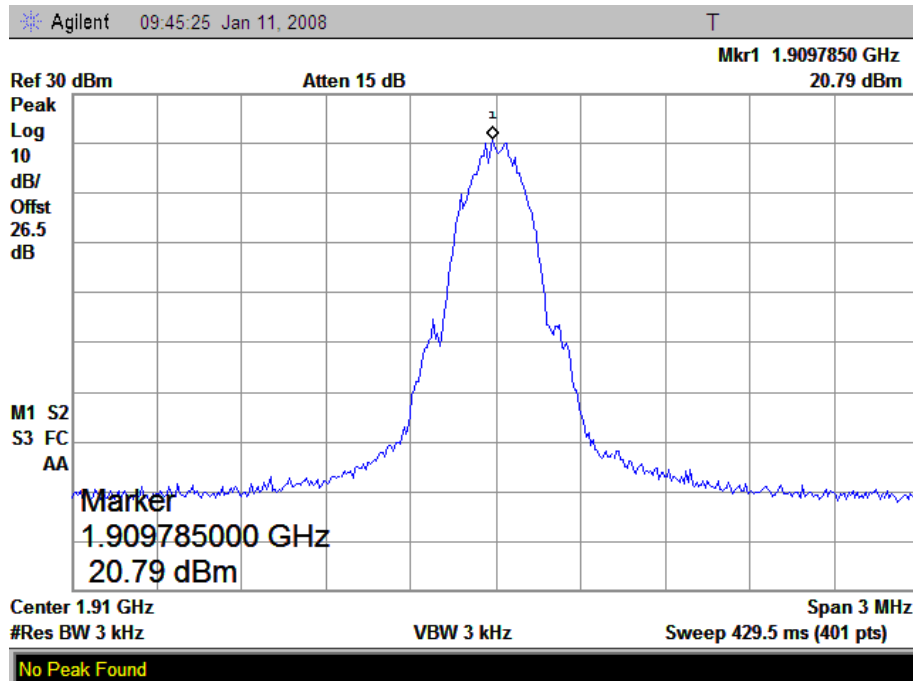

4.3 Conducted RF Output Power

4.3.1 Requirement

According to FCC §2.1046 (a), for transmitters other than single sideband, independent sideband and controlled carrier radiotelephone, power output shall be measured at the RF output terminals when the transmitter is adjusted in accordance with the tune-up procedure to give the values of current and voltage on the circuit elements specified in §2.1033 (c)(8). The electrical characteristics of the radio frequency load attached to the output terminals when this test is made shall be stated.

4.3.2 Test Procedure

1. Perform test system setup as section 4.1.1 (the radio frequency load attached to the EUT antenna terminal is 50Ω).
2. The resolution bandwidth of the Spectrum Analyzer is set to be comparable to the emission bandwidth of the transmitter, e.g. for GSM modulated signal (here used): $RBW=VBW=1\text{MHz}$, for CDMA modulated signal: $RBW=VBW=3\text{MHz}$.
3. The low, middle and the high channels are selected to perform tests respectively. Set the TCH number to 128(low) 190(middle) and 251(high) for GSM 850MHz; TCH number to 512(low) 661(middle) and 810(high) for PCS 1900MHz.
4. Set the frequency range of the Spectrum Analyzer suitably to capture the waveform; search peak and mark it; finally record the peak and the plot.

4.3.3 Test Result

I GSM 850MHz Band

No.	Channel Number	Frequency (MHz)	Measured Power		Rated Power	
			dBm	W	dBm	W
1	128	824.2	30.14	1.03	33	2
2	190	836.6	30.16	1.04	33	2
3	251	848.8	30.92	1.24	33	2

1. Plot when the TCH number set to 128:

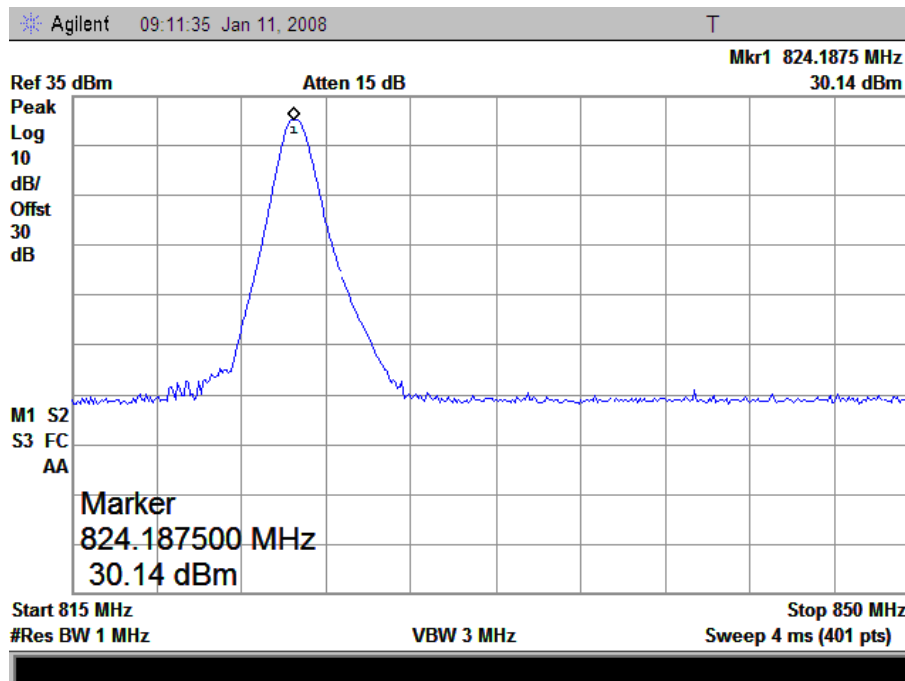

2. Plot when the TCH number set to 190:

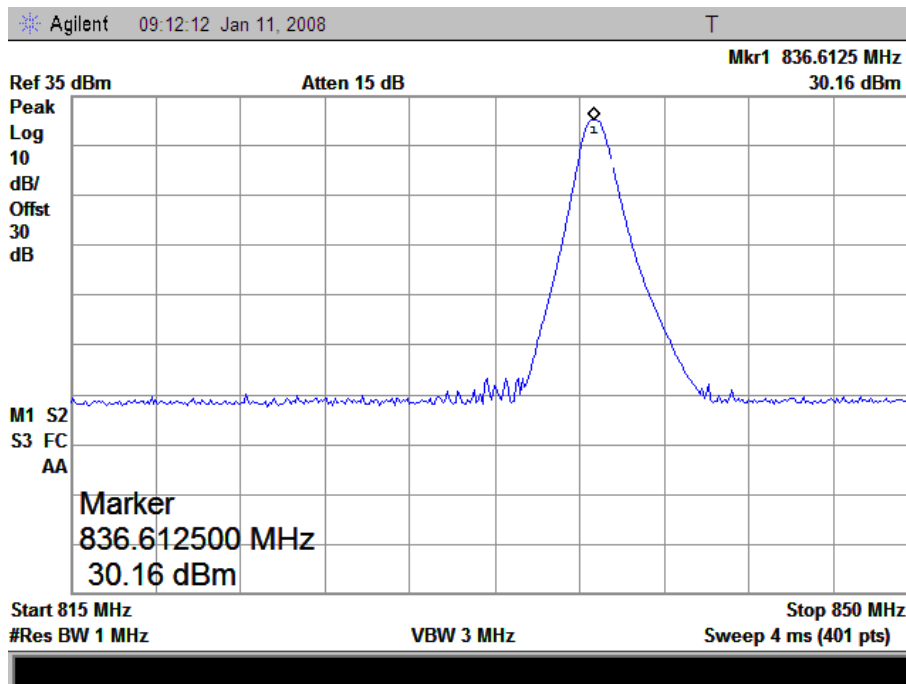

3. Plot when the TCH number set to 251:

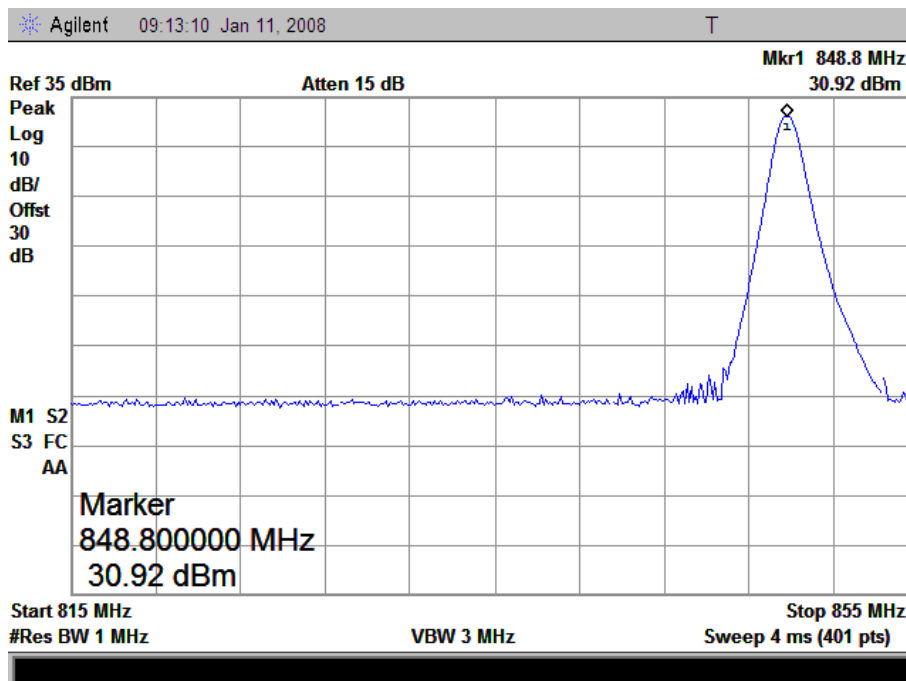

II PCS 1900MHz Band

No.	Channel	Frequency (MHz)	Measured Power		Rated Power	
			dBm	Watt	dBm	Watt
1	512	1850.2	29.38	0.87	30	1
2	661	1880.0	28.66	0.74	30	1
3	810	1909.8	28.62	0.73	30	1

1. Plot when the TCH number set to 512:

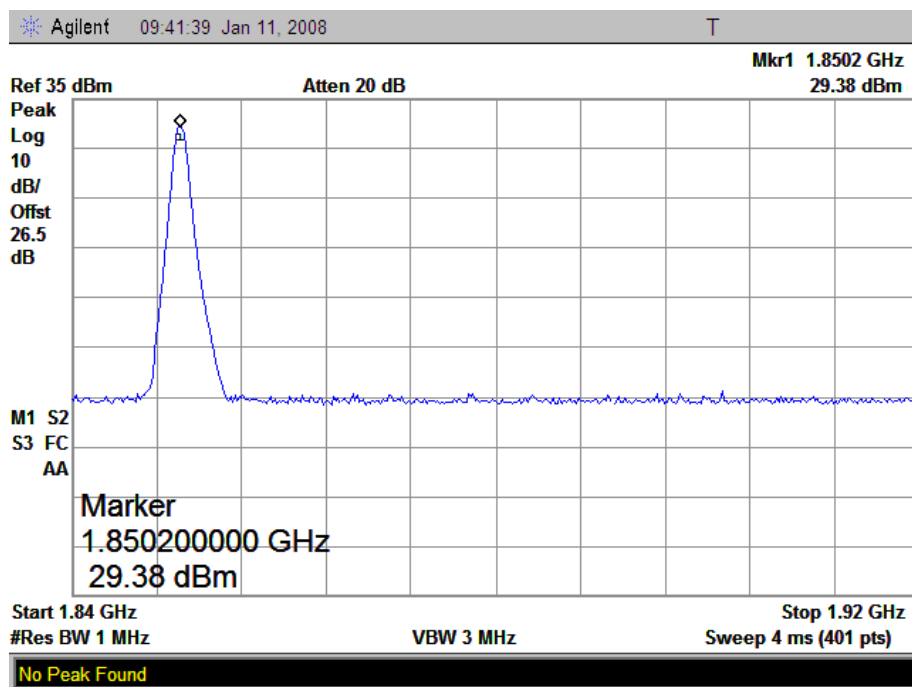

4.4 Occupied Bandwidth

4.4.1 Occupied Bandwidth Definition

According to FCC §2.1049, the occupied bandwidth is the frequency bandwidth such that, below its lower and above its upper frequency limits, the mean powers radiated are each equal to 0.5 percent of the total mean power radiated by a given emission.

Occupied bandwidth is also known as the 99% emission bandwidth, or 20dB bandwidth ($10 \cdot \log 1\%$ is equal to 20dB) taking the total RF output power as reference.

4.4.2 Test Procedure

1. Perform test system setup as section 4.1.1.
2. The resolution bandwidth of the Spectrum Analyzer is set to at least one percent of the emission bandwidth, e.g. for GSM modulated signal (here used): $RBW=VBW=3kHz$, for CDMA modulated signal: $RBW=VBW=30kHz$.
3. The low, middle and the high channels are selected to perform tests respectively. Set the TCH number to 128(low) 190(middle) and 251(high) for GSM 850MHz; TCH number to 512(low) 661(middle) and 810(high) for PCS 1900MHz.
4. Set the frequency range of the Spectrum Analyzer suitably to capture the waveform; search peak; make a line whose value is 20dB lower than the peak; mark two points which the line intersected the waveform at; finally record the delta of the two points as the occupied bandwidth and the plot.

4.4.3 Test Result

I GSM 850MHz Band

No.	Channel	Frequency (MHz)	Measured Occupied Bandwidth (kHz)
1	128	824.2	285.0
2	190	836.6	292.5
3	251	848.8	285.0

- Plot when the TCH number set to 128:

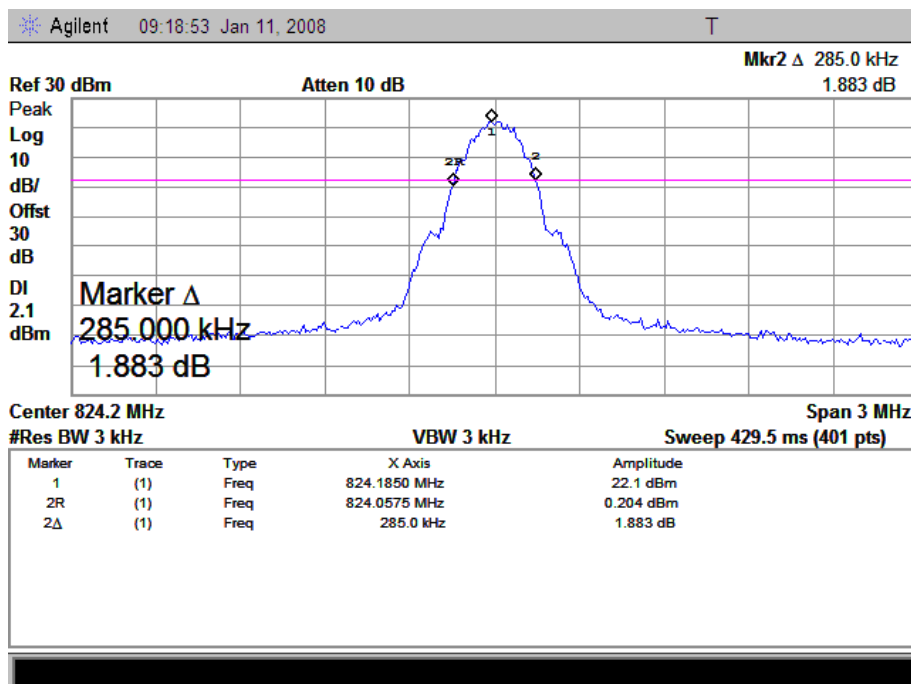

2. Plot when the TCH number set to 190:

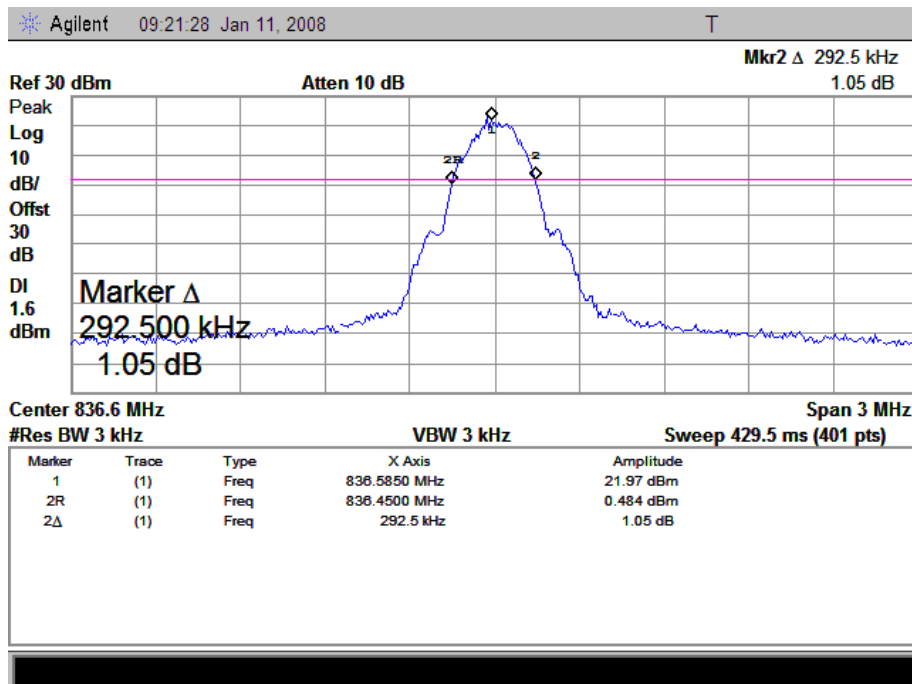

3. Plot when the TCH number set to 810:

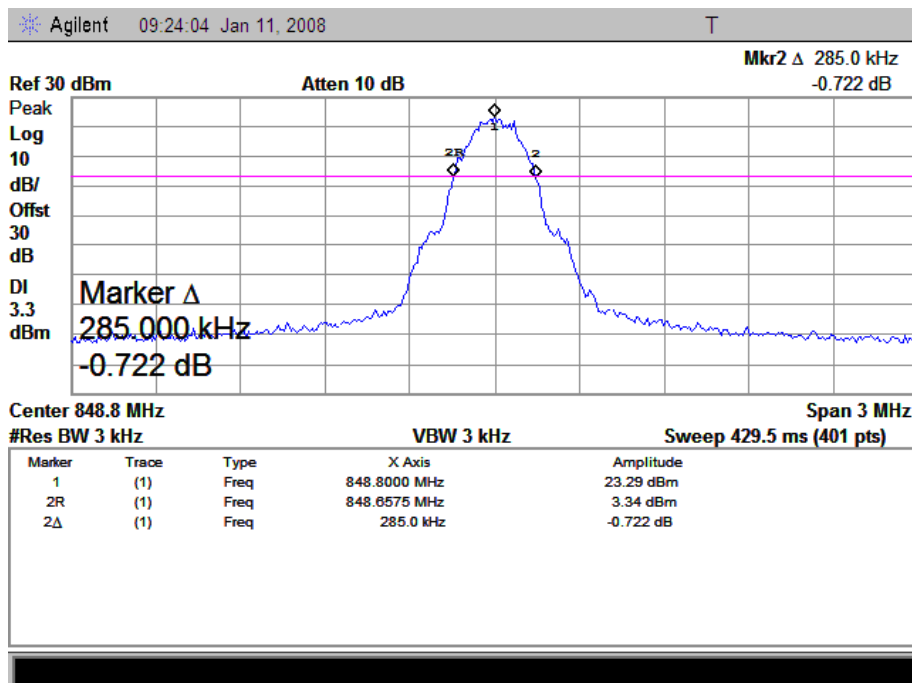

II PCS 1900MHz Band

No.	Channel	Frequency (MHz)	Measured Occupied Bandwidth (kHz)
1	512	1850.2	285.0
2	661	1880.0	285.0
3	810	1909.8	285.0

1. Plot when the TCH number set to 512:

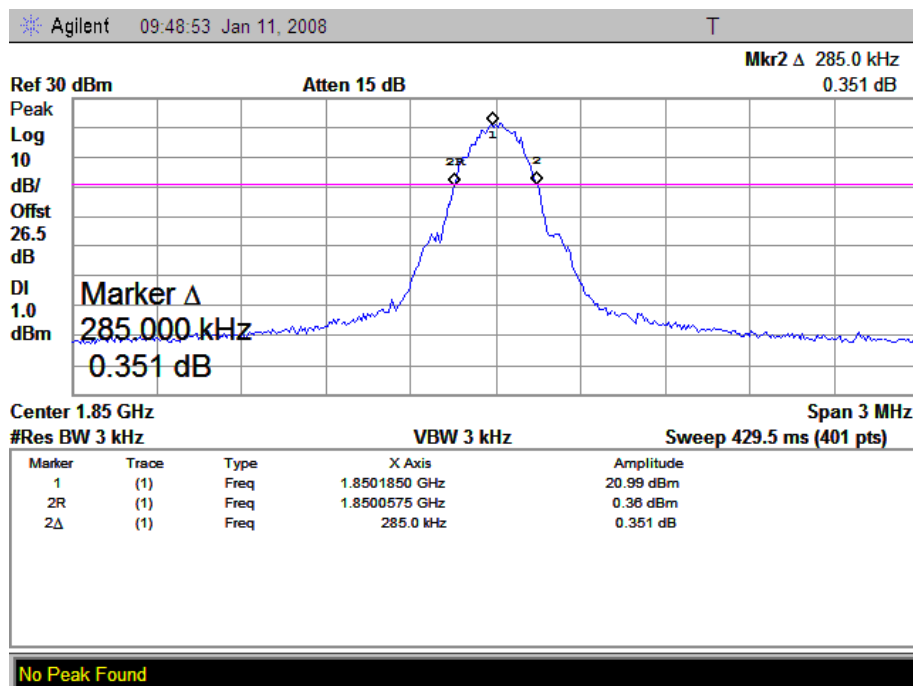

2. Plot when the TCH number set to 661:

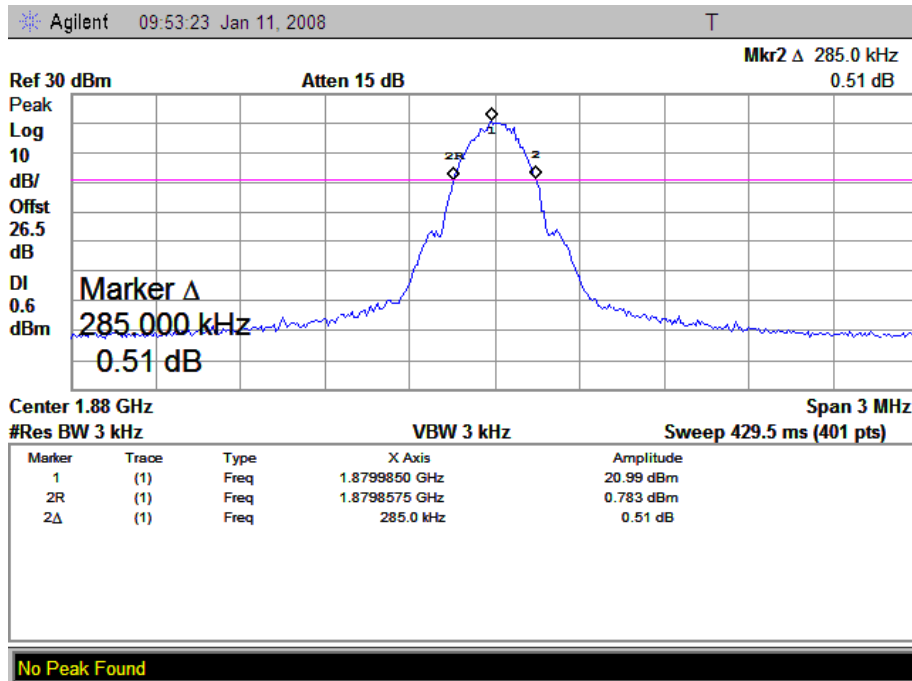

3. Plot when the TCH number set to 810:

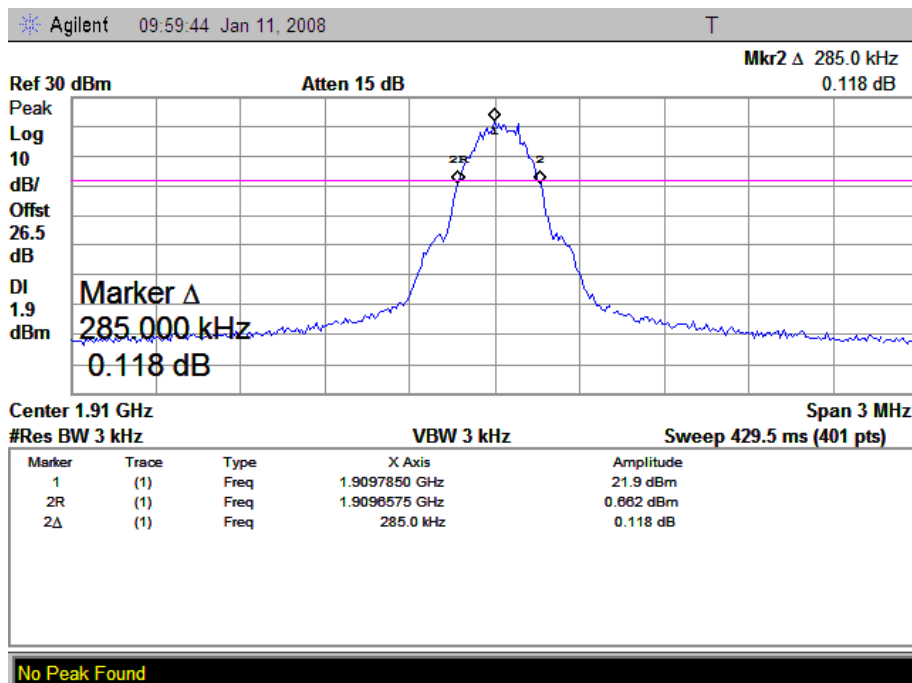

4.5 Conducted Spurious Emission

4.5.1 Requirement

According to FCC §22.917(a) and §24.238(a), the power of any emission outside of the authorized operating frequency ranges must be attenuated below the transmitting power (P) by a factor of at least $43+10*\log(P)$ dB. This calculated to be -13dBm.

According to FCC §22.917 (a) and §24.238(b), in the 1MHz bands immediately outside and adjacent to the frequency block a resolution bandwidth of at least one percent of the emission bandwidth of the fundamental emission of the transmitter may be employed. Thus the 26dB emission bandwidth is measurement for showing compliance at the band-edge.

4.5.2 Test Procedure

1. Perform test system setup as section 4.1.1.
2. Make a limit line whose value is -13dBm on the Spectrum Analyzer.
3. The lowest, middle and the highest channels are selected to perform tests respectively. Set the TCH number to 128(low) 190(middle) and 251(high) for GSM 850MHz; TCH number to 512(low) 661(middle) and 810(high) for PCS 1900MHz.
4. Set the RBW of the Spectrum Analyzer to 1MHz, and the measuring frequency range from 9kHz to 10th harmonic of the fundamental frequency; mark the fundamental frequency and the harmonics thereof; finally record the harmonics and the plot.
5. In the 1MHz bands immediately outside and adjacent to the frequency black, the RBW of the Spectrum Analyzer was set to at least one percent of the emission bandwidth of the fundamental emission of the transmitter, e.g. for GSM modulated signal (here used): RBW=3kHz, for CDMA modulated signal: RBW=30kHz.

4.5.3 Test Result

4.5.3.1 Table for the Harmonics and Plots for the Spurious Emission

I GSM 850MHz Band

1. Table for the Harmonics:

NOTE: “---” in the table following means that the emission power was too small to be measured and was at least 12dB below the limit.

No.	Frequency (MHz)	Emission Power (dBm)	Limit (dBm)
TCH number set to 128 (824.20MHz)			
1	1648.40	---	-13
2	2472.60	-30.90	-13
3	3296.80	---	-13
4	4121.00	---	-13
5	4945.20	---	-13
6	5769.40	---	-13
7	6593.60	---	-13
8	7417.80	---	-13
9	8242.00	---	-13
TCH number set to 190 (836.60MHz)			
10	1673.20	---	-13
11	2509.80	-32.78	-13
12	3346.40	---	-13
13	4183.00	---	-13
14	5019.60	---	-13
15	5856.20	---	-13
16	6692.80	---	-13
17	7529.40	---	-13
18	8366.00	---	-13
TCH number set to 251 (848.80MHz)			
19	1697.60	---	-13
20	2546.40	-29.17	-13
21	3395.20	---	-13
22	4244.00	---	-13
23	5092.80	---	-13
24	5941.60	---	-13
25	6790.40	---	-13
26	7639.20	---	-13
27	8488.00	---	-13

2. Plot for Spurious Emission:

The measuring frequency range was from 9kHz to 10GHz.

NOTE: The marker points are the Mobile Phone and/or System Simulator transmitting frequencies which should be ignored.

2.1 Plot when the TCH number set to 128:

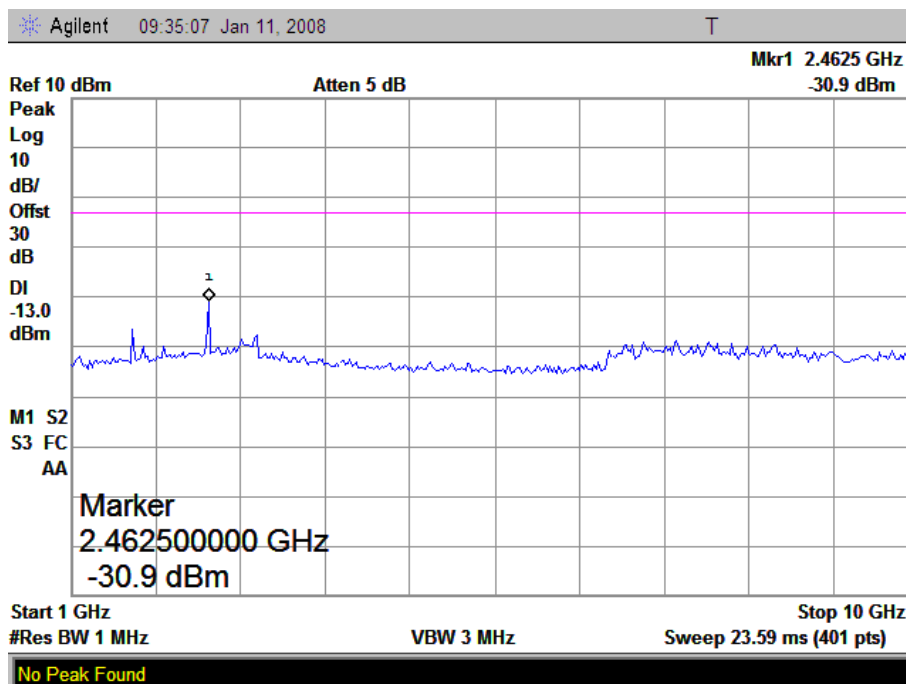
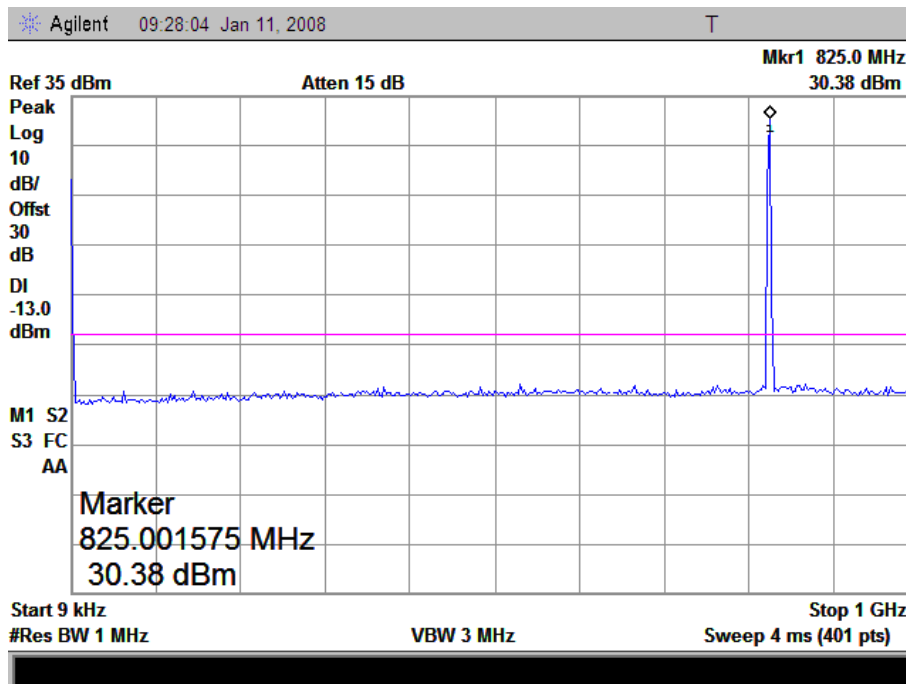

2.2 Plot when the TCH number set to 190:

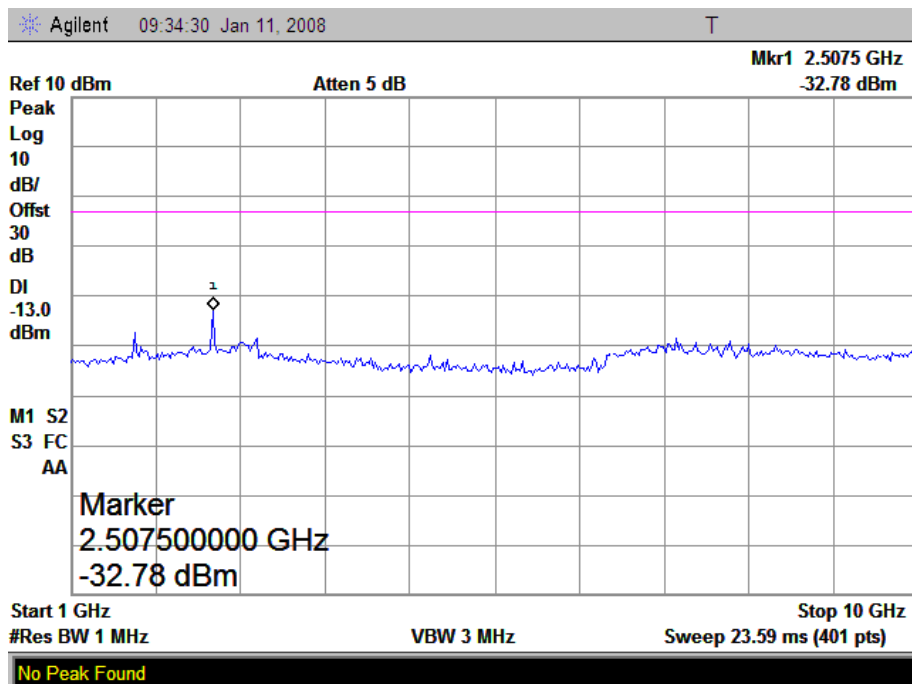
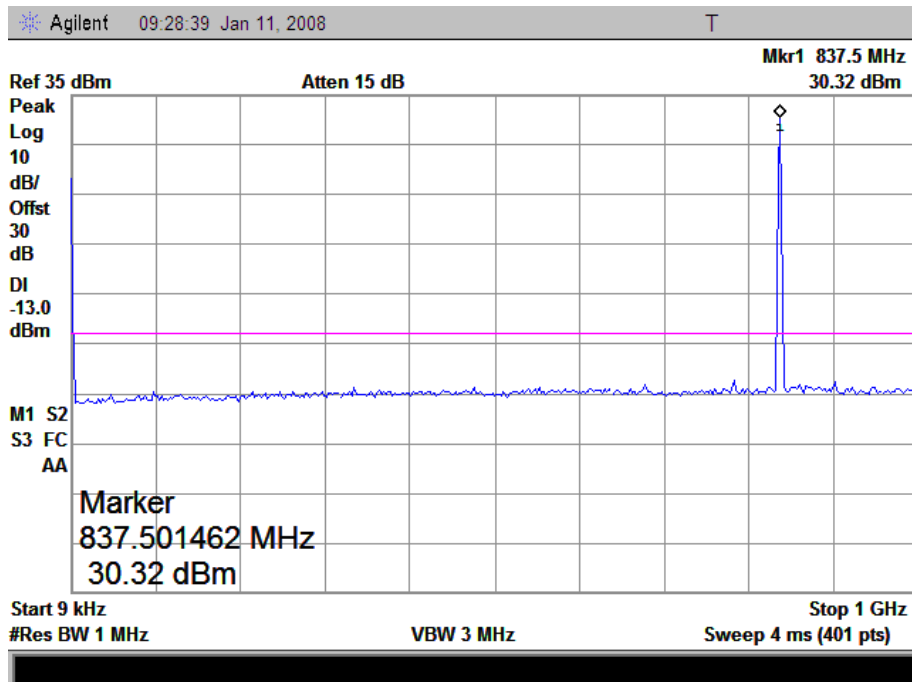

2.3 Plot when the TCH number set to 251:

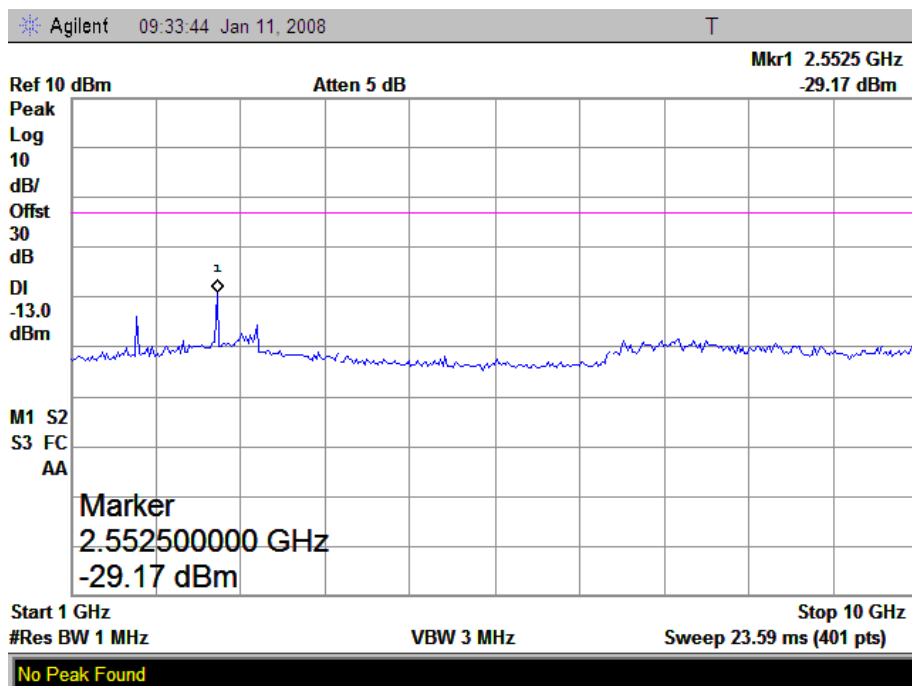
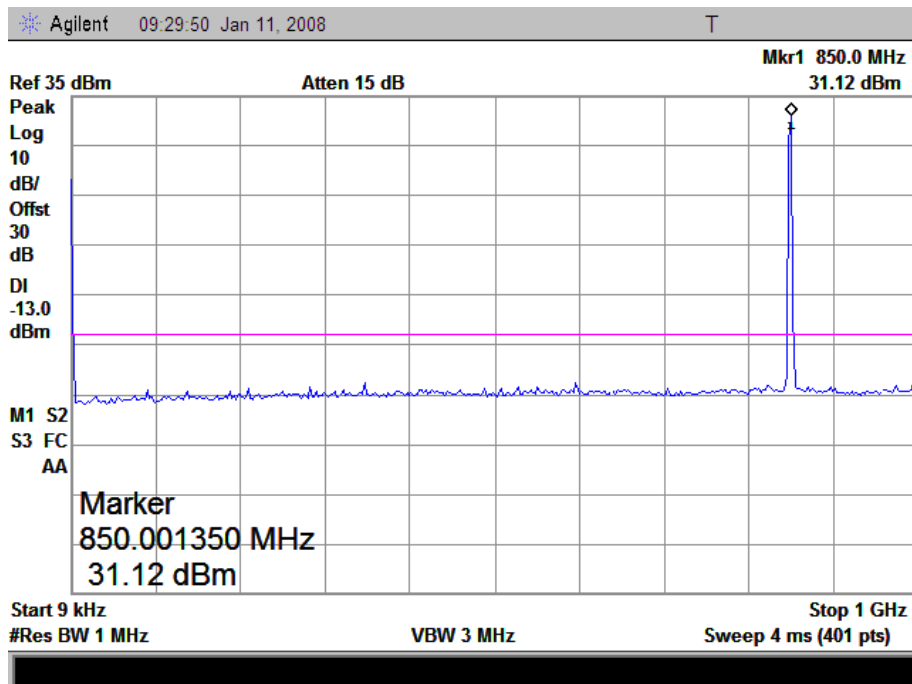

Plot for Band-edge

- Plot when the TCH number set to 128:

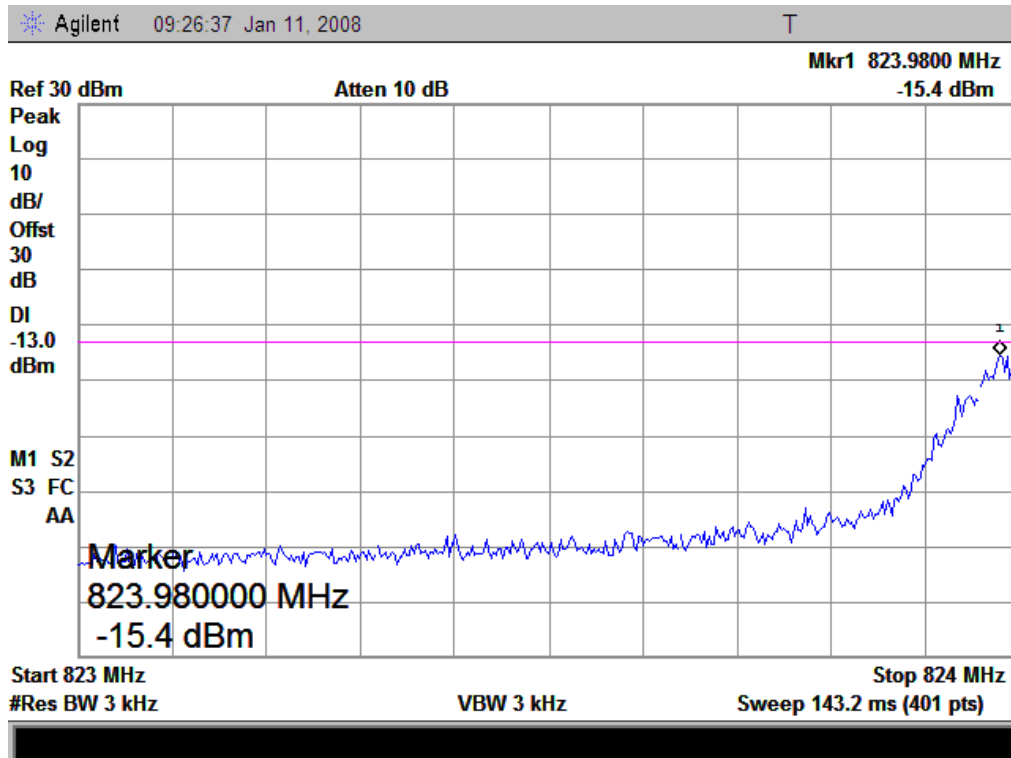

- Plot when the TCH number set to 251:

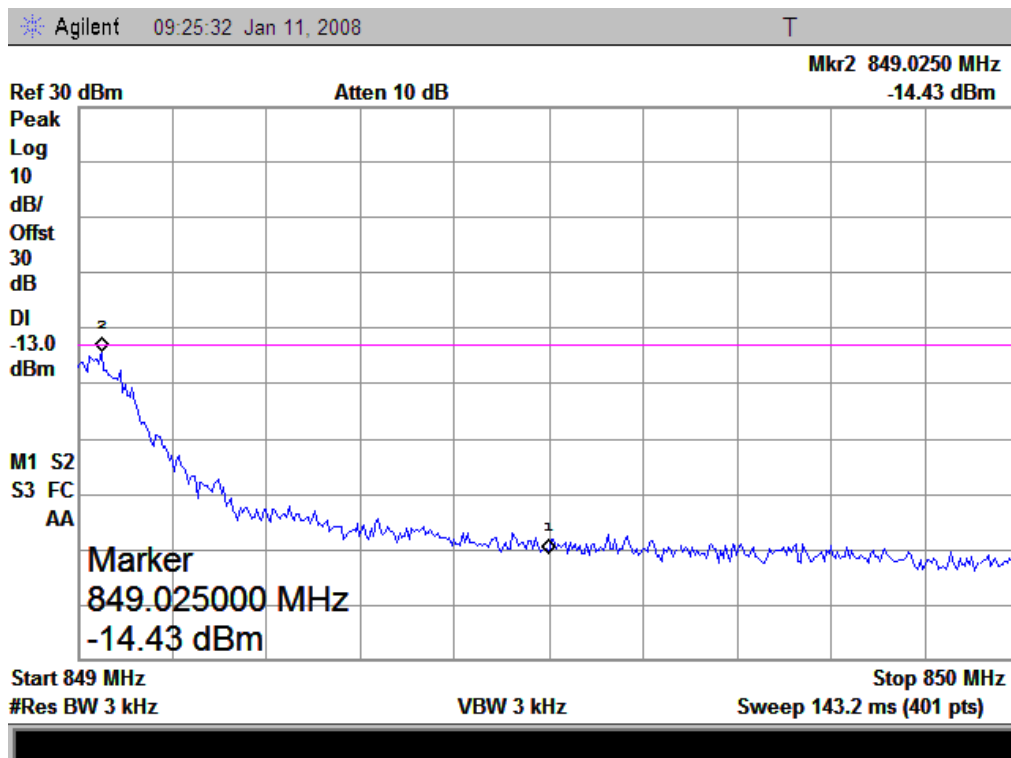

II PCS 1900MHz Band

1. Table for the harmonics:

Note: The symbol “---” in the table below means that the emission power is too small to be measured and is at least 12dB below the limit.

No.	Frequency (MHz)	Emission Power (dBm)	Limit (dBm)
TCH number set to 512 (1850.20MHz)			
1	3700.40	---	-13
2	5550.60	---	-13
3	7400.80	---	-13
4	9251.00	-25.38	-13
5	11101.20	---	-13
6	12951.40	---	-13
7	14801.60	---	-13
8	16651.80	---	-13
9	18502.00	---	-13
TCH number set to 661 (1880.00MHz)			
10	3760.00	---	-13
11	5640.00	---	-13
12	7520.00	---	-13
13	9400.00	-20.9	-13
14	11280.00	---	-13
15	13160.00	---	-13
16	15040.00	---	-13
17	16920.00	---	-13
18	18800.00	---	-13
TCH number set to 810 (1909.80MHz)			
19	3819.60	---	-13
20	5729.40	---	-13
21	7639.20	---	-13
22	9549.00	-23.99	-13
23	11458.80	---	-13
24	13368.60	---	-13
25	15278.40	---	-13
26	17188.20	---	-13
27	19098.00	---	-13

2. Plots for Spurious Emission:

The measuring frequency range was from 9kHz to 20GHz.

NOTE: The marker points are the Mobile Phone and/or System Simulator transmitting frequencies which should be ignored.

2.1 Plot when the TCH number set to 512:

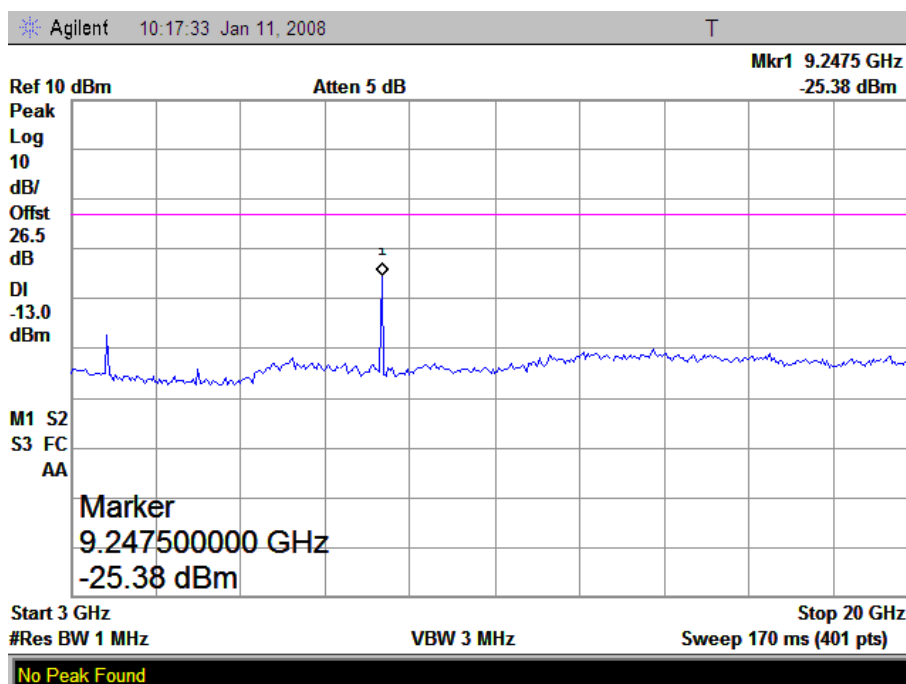
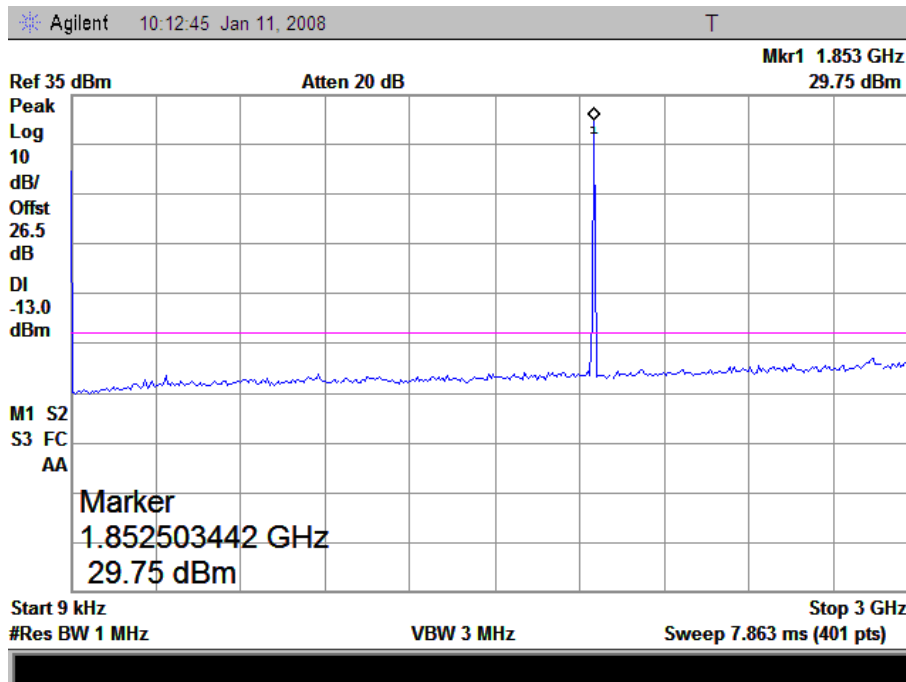

2.2 Plot when the TCH number set to 661:

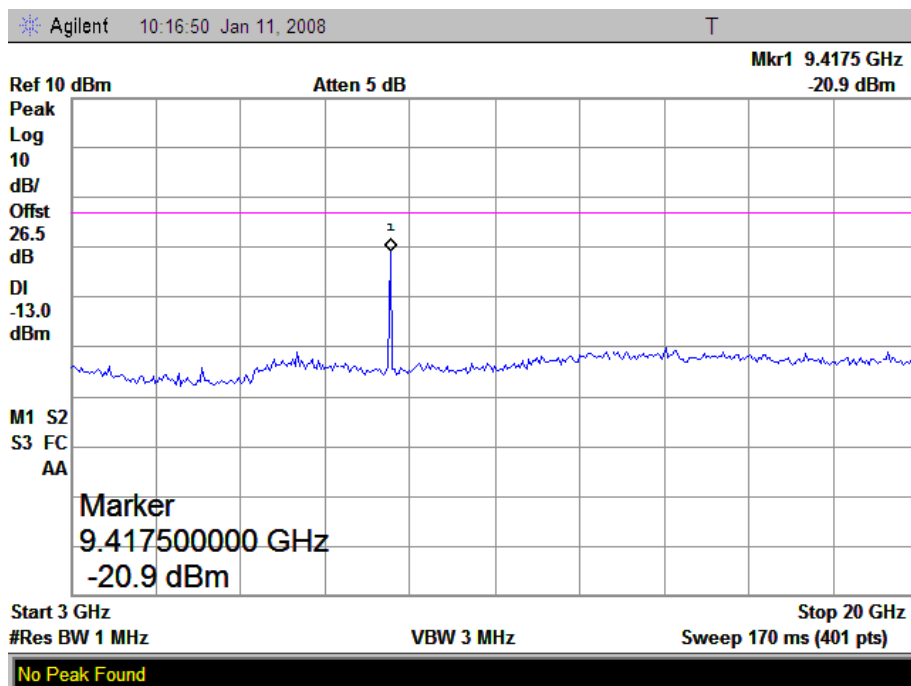
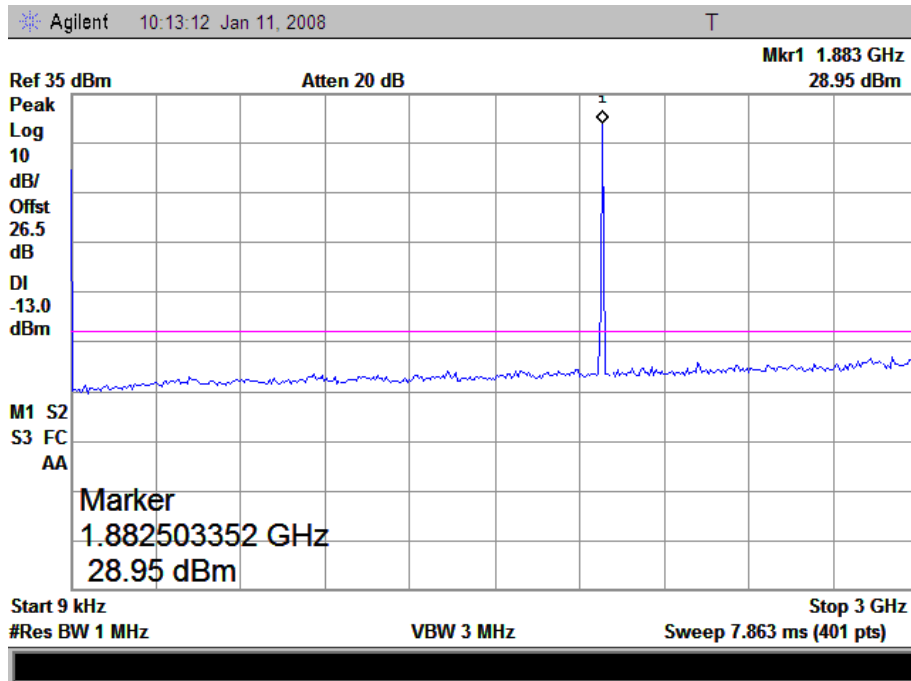

2.3 Plot when the TCH number set to 810:

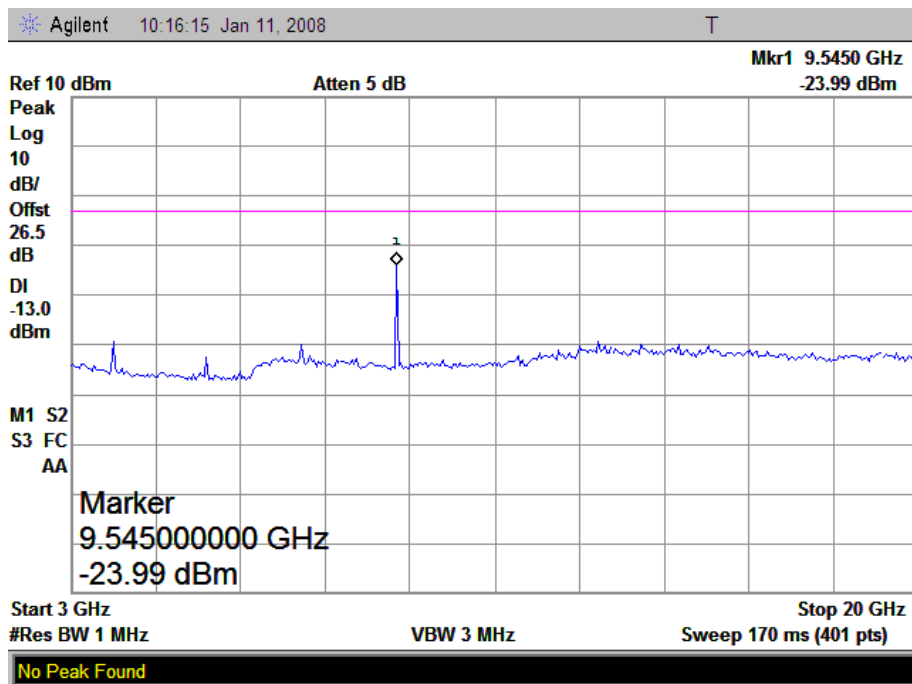
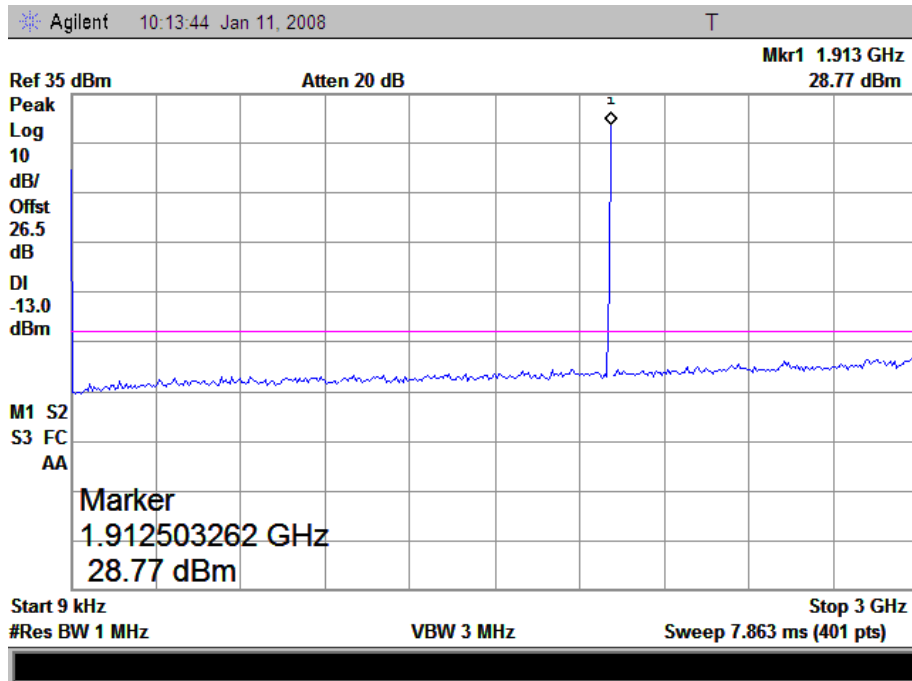

Plot for Band-edge

1. Plot when the TCH number set to 512:

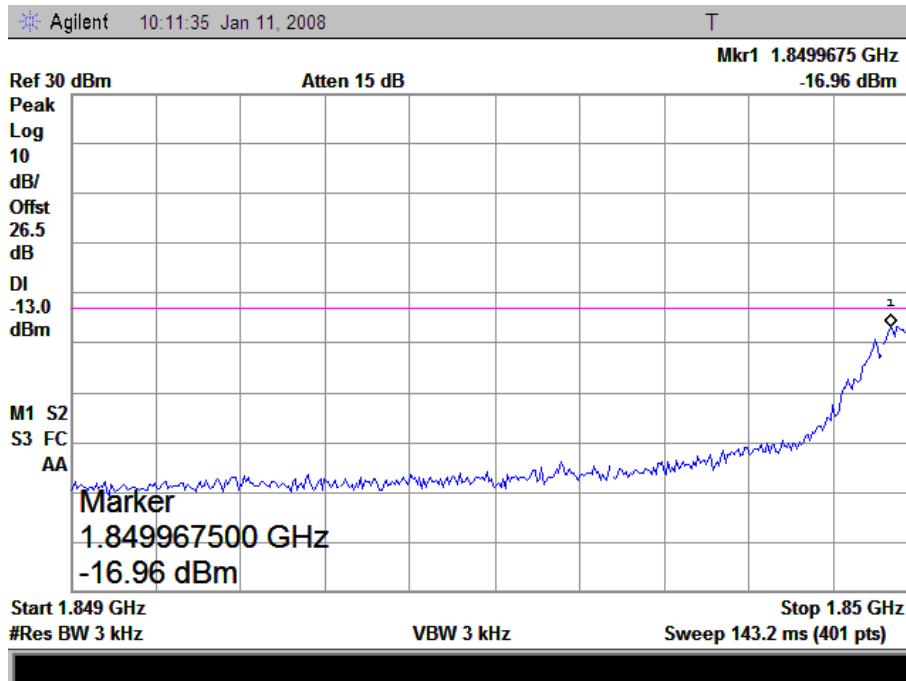

2. Plot when the TCH number set to 810:

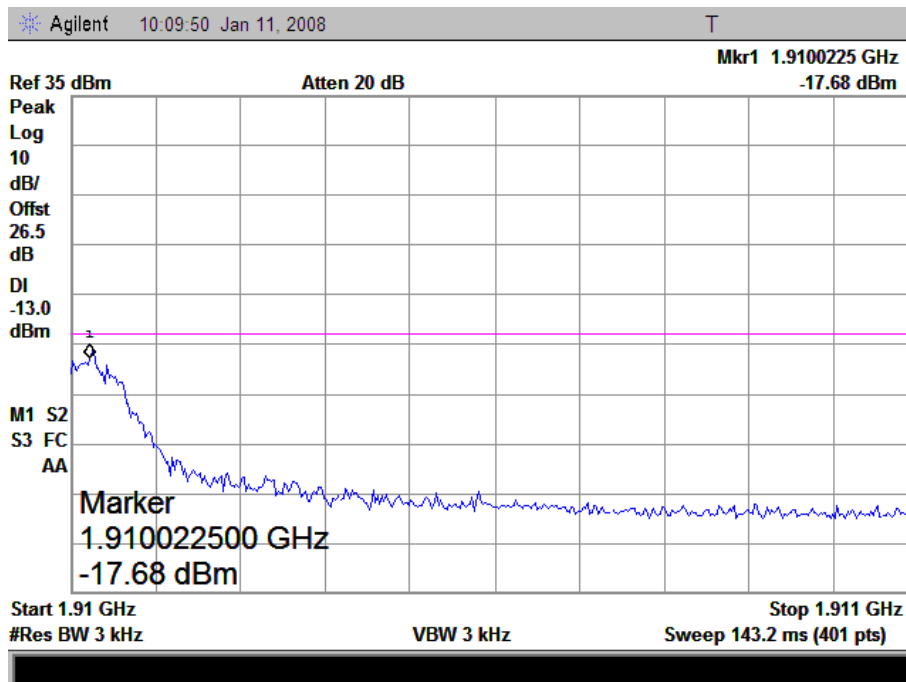

4.6 Transmitter Radiated Power (EIRP/ERP)

4.6.1 Requirement

According to FCC §22.913, the ERP of Cellular mobile transmitters must not exceed 7 Watts (38.5dBm).

According to FCC §24.232, the broadband PCS mobile station are limited to 2 Watts (33dBm) EIRP peak power.

4.6.2 Test Procedure

1. Perform test system setup as section 4.1.2.
2. The resolution bandwidth of the Spectrum Analyzer is set to be comparable to the emission bandwidth of the transmitter, e.g. for GSM modulated signal (here used): RBW=VBW=1MHz, for CDMA modulated signal: RBW=VBW=3MHz.
3. The low, middle and the high channels are selected to perform tests respectively. Set the TCH number to 128(low) 190(middle) and 251(high) for GSM 850MHz; TCH number to 512(low) 661(middle) and 810(high) for PCS 1900MHz.
4. Employ the bi-log Test Antenna as the test system receiving antenna; set the polarization of the Test Antenna to be the same as that of the EUT transmitting antenna.
5. Set the frequency range of the Spectrum Analyzer suitably to capture the waveform; actuate the Turn Table to turn from 0 degrees to 360 degrees to find the maximum reading via the Spectrum Analyzer, mark the peak; finally record the peak and the plot.

4.6.3 Test Result

I GSM 850MHz Band

No.	Channel	Frequency (MHz)	Measured ERP		Limit ERP		Result
			dBm	W	dBm	W	
1	128	824.20	23.19	0.21	38.5	7	PASS
2	190	836.60	24.50	0.28	38.5	7	PASS
3	251	848.80	21.99	0.16	38.5	7	PASS

1. Plot when the TCH number set to 128:

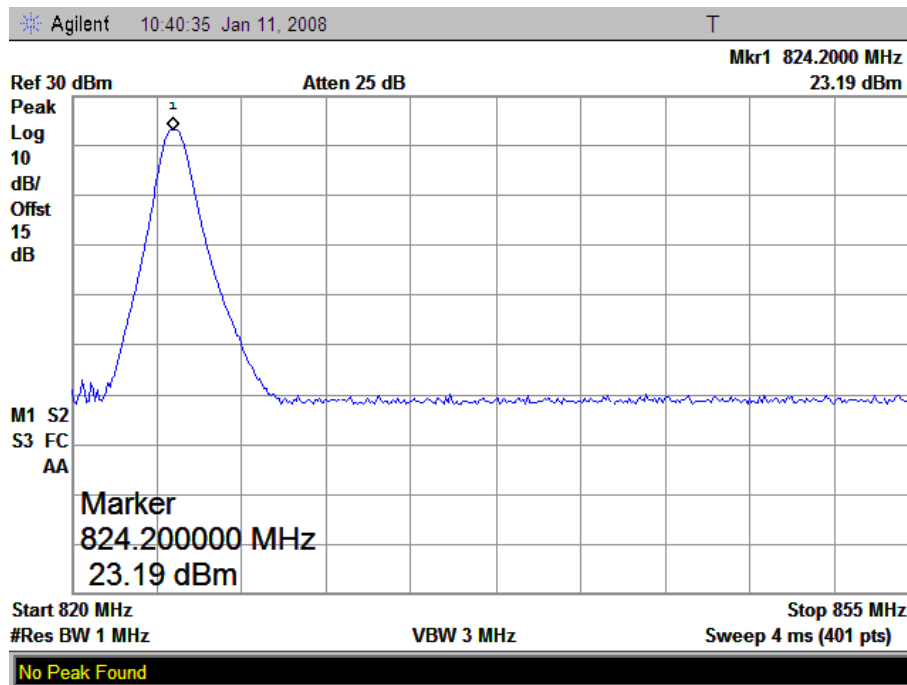

2. Plot when the TCH number set to 190:

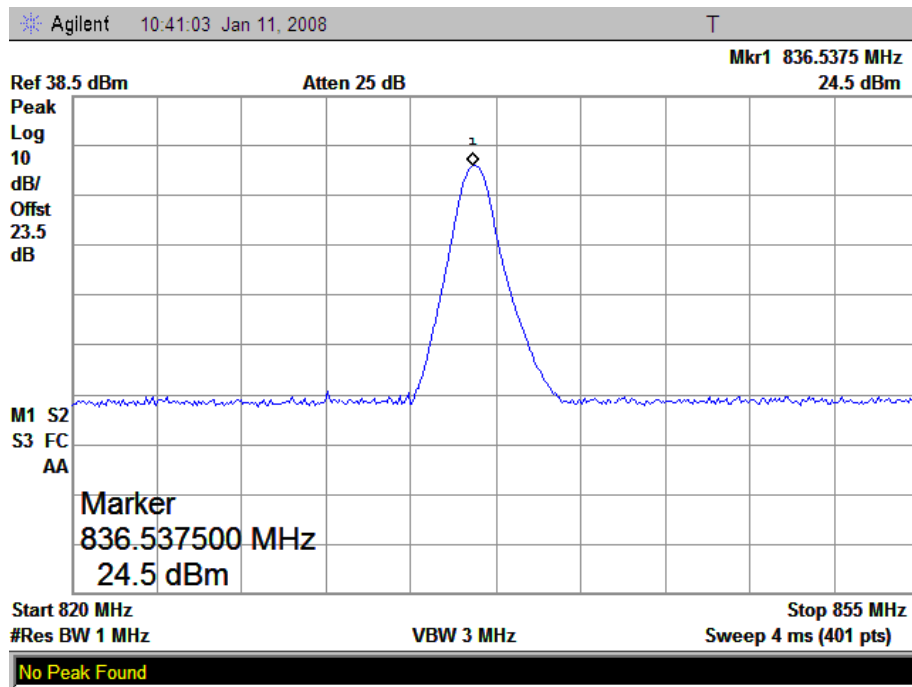

3. Plot when the TCH number set to 251:

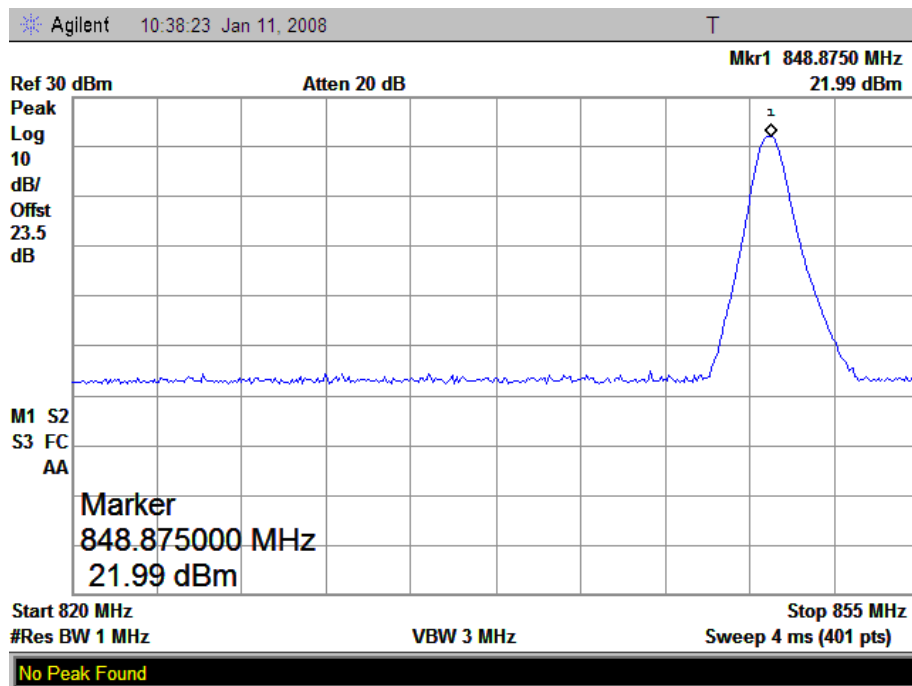

II PCS 1900MHz Band

No.	Channel	Frequency (MHz)	Measured EIRP		Limit EIRP		Result
			dBm	W	dBm	W	
1	512	1850.2	20.37	0.11	33	2	PASS
2	661	1880.0	21.48	0.14	33	2	PASS
3	810	1909.8	19.85	0.097	33	2	PASS

1. Plot when the TCH number set to 512:

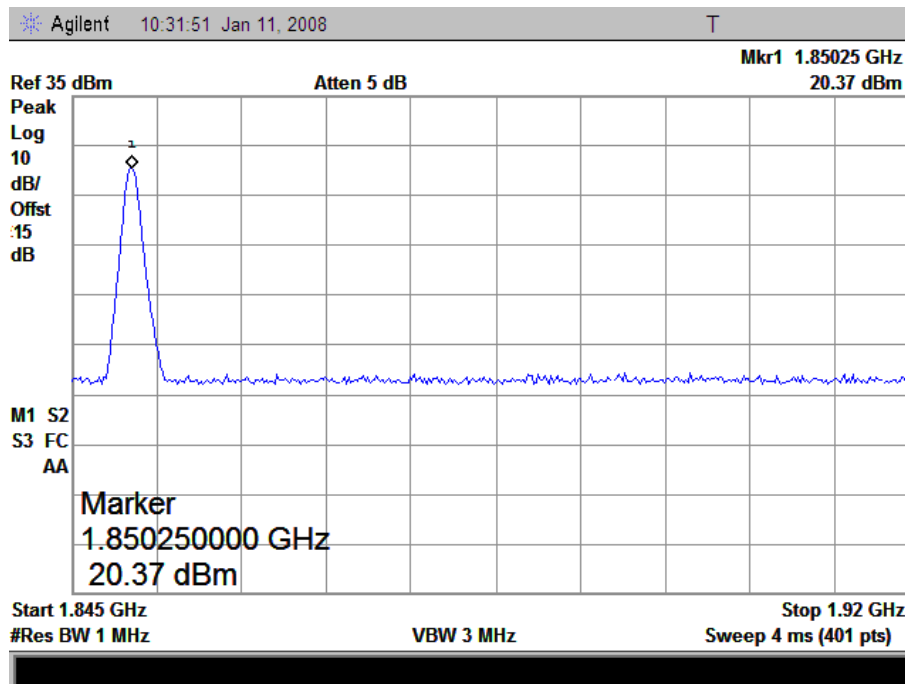

2. Plot when the TCH number set to 661:

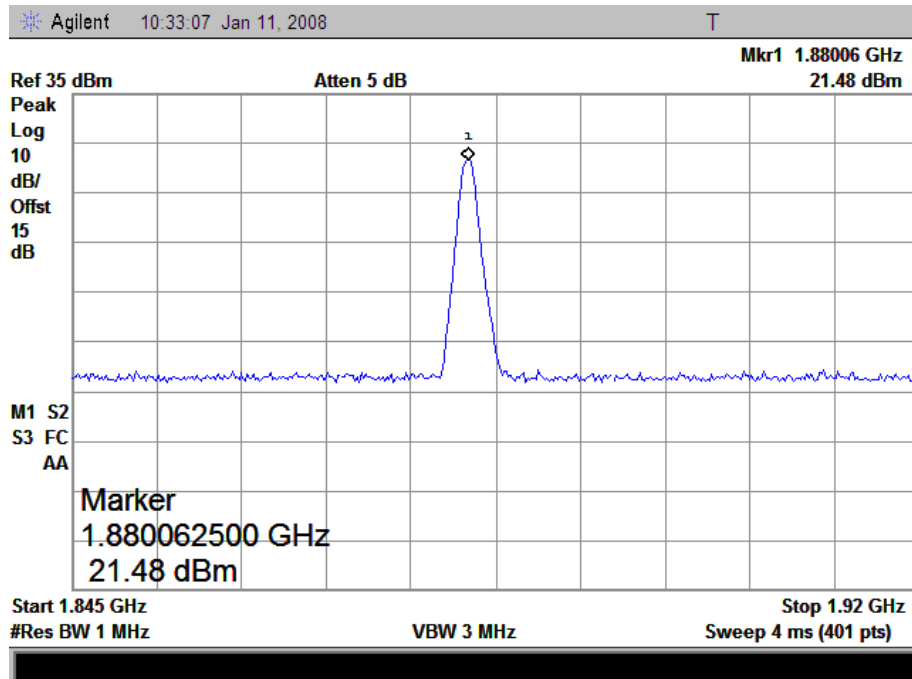

3. Plot when the TCH number set to 810:

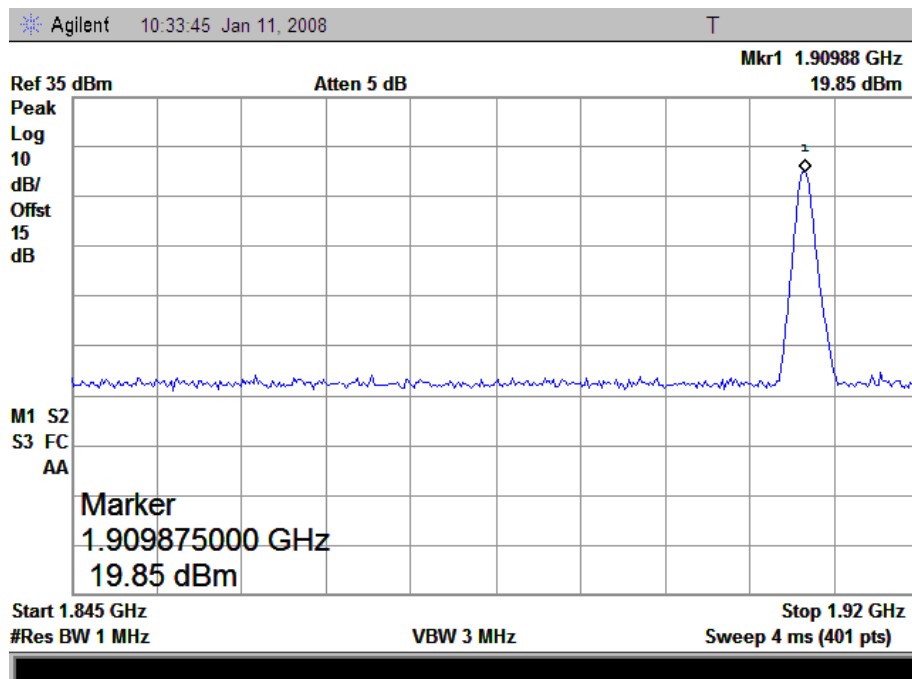

4.7 Radiated Spurious Emission

4.7.1 Requirement

According to FCC §22.917(a), the power of any emission outside of the authorized operating frequency ranges must be attenuated below the transmitting power (P) by a factor of at least $43+10*\log(P)$ dB. This calculated to be -13dBm.

4.7.2 Test Procedure

1. Perform test system setup as section 4.1.2.
2. Make a limit line whose value is -13dBm on the Spectrum Analyzer, and set the RBW of the Spectrum Analyzer to 1MHz.
3. The low, middle and the high channels are selected to perform tests respectively. Set the TCH number to 128(low) 190(middle) and 251(high) for GSM 850MHz; TCH number to 512(low) 661(middle) and 810(high) for PCS 1900MHz.
4. Employ the bi-log Test Antenna as the test system receiving antenna and set the frequency range of the Spectrum Analyzer from 30MHz to 3GHz.
5. The measurement is performed with the Test Antenna at both horizontal and vertical polarization respectively. Set the polarization of the Test Antenna to be horizontal.
6. Actuate the Turn Table to turn from 0 degrees to 360 degrees to find the maximum reading via the Spectrum Analyzer, mark the fundamental frequency and the harmonics thereof, after then record the harmonics and the plot.
7. Set the polarization of the Test Antenna to be vertical, then repeat step 6.
8. Employ the horn Test Antenna as the test system receiving antenna and set the frequency range of the Spectrum Analyzer from 3GHz to 10th harmonic of the fundamental frequency (here used 10GHz), then repeat step 5 to 7.

4.7.3 Test Result

4.7.3.1 Table for the Harmonics

NOTE: “---” in the table following means that the emission power was too small to be measured and was at least 12dB below the limit.

I GSM 850MHz Band

No.	Frequency (MHz)	Emission Power (dBm)		Limit (dBm)
		Test Antenna Vertical	Test Antenna Horizontal	
TCH number set to 128 (824.20MHz)				
1	1648.40	-39.26	-41.01	-13
2	2472.60	-46.31	-48.39	-13
3	3296.80	---	---	-13
4	4121.00	---	---	-13
5	4945.20	---	---	-13
6	5769.40	---	---	-13
7	6593.60	---	---	-13
8	7417.80	---	---	-13
9	8242.00	---	---	-13
TCH number set to 190 (836.60MHz)				
10	1673.20	-41.06	-44.07	-13
11	2509.80	-47.45	-49.13	-13
12	3346.40	---	---	-13
13	4183.00	---	---	-13
14	5019.60	---	---	-13
15	5856.20	---	---	-13
16	6692.80	---	---	-13
17	7529.40	---	---	-13
18	8366.00	---	---	-13
TCH number set to 251 (848.80MHz)				
19	1697.60	-41.13	-44.38	-13
20	2546.40	-47.25	-50.44	-13
21	3395.20	---	---	-13
22	4244.00	---	---	-13
23	5092.80	---	---	-13
24	5941.60	---	---	-13
25	6790.40	---	---	-13
26	7639.20	---	---	-13
27	8488.00	---	---	-13



II PCS 1900MHz Band

No.	Frequency (MHz)	Emission Power (dBm)		Limit (dBm)
		Test Antenna Vertical	Test Antenna Horizontal	
TCH number set to 512 (1850.20MHz)				
1	3700.40	-37.54	-40.32	-13
2	5550.60	-41.37	-46.28	-13
3	7400.80	---	---	-13
4	9251.00	---	---	-13
5	11101.20	---	---	-13
6	12951.40	---	---	-13
7	14801.60	---	---	-13
8	16651.80	---	---	-13
9	18502.00	---	---	-13
TCH number set to 661 (1880.0MHz)				
10	3760.00	-40.34	-44.71	-13
11	5640.00	-46.38	-49.01	-13
12	7520.00	---	---	-13
13	9400.00	---	---	-13
14	11280.00	---	---	-13
15	13160.00	---	---	-13
16	15040.00	---	---	-13
17	16920.00	---	---	-13
18	18800.00	---	---	-13
TCH number set to 810 (1909.80MHz)				
19	3819.60	-38.43	-44.08	-13
20	5729.40	-44.47	-49.63	-13
21	7639.20	---	---	-13
22	9549.00	---	---	-13
23	11458.80	---	---	-13
24	13368.60	---	---	-13
25	15278.40	---	---	-13
26	17188.20	---	---	-13
27	19098.00	---	---	-13

4.8 Frequency Stability

4.8.1 Frequency Stability Requirement

According to FCC §22.355 and §24.235, the frequency stability shall be sufficient to ensure that the fundamental emission stays within the authorized frequency block.

According to FCC §2.1055, the test conditions are:

- (a) Temperature:
The temperature is varied from -30°C to $+50^{\circ}\text{C}$ at intervals of not more than 10°C .
- (b) Primary Supply Voltage:
For hand carried battery powered equipment, the primary supply voltage is reduced to the battery operating end point which shall be specified by the manufacture. The supply voltage shall be measured at the input to the cable normally provided with the equipment, or at the power supply terminals if cables are not normally provided.

4.8.2 Test Procedure

1. Perform test system setup as section 4.1.3.
2. Set the voltage of the DC Power Supply to normal supply voltage (here used 3.7V) and the temperature of the Temperature Chamber to vary from -30°C to $+50^{\circ}\text{C}$ at intervals of 10°C .
3. At each temperature level, the EUT is powered off and kept in the Temperature Chamber for two hours. After sufficient stabilization, turn on the EUT, command it via the System Simulator (SS) to operate at the maximum output power i.e. Power Control Level (PCL) = 5 and Power Class = 4 for GSM 850MHz (Power Control Level (PCL) = 0 and Power Class = 1 for PCS 1900MHz), and then establish a communication link between the EUT and the SS.
4. The low, middle and the high channels are selected to perform tests respectively. Set the TCH number to 128(low) 190(middle) and 251(high) for GSM 850MHz; TCH number to 512(low) 661(middle) and 810(high) for PCS 1900MHz.
5. The frequency deviation is measured (directly read from the SS, which can report the parameter) within three minutes.
6. Adjust the temperature of the Temperature Chamber as specified in step 2, then repeat step 3 to 5.
7. Set the voltage of the DC Power Supply to high extreme supply voltage (here used 4.2V) and the temperature of the Temperature Chamber to normal (here used $+22^{\circ}\text{C}$), then repeat step 3 to 6.
8. Set the voltage of the DC Power Supply to low extreme supply voltage (here used 3.6V) and the temperature of the Temperature Chamber to normal (here used $+22^{\circ}\text{C}$), then repeat step 3 to 6.

4.8.3 Test Result

I GSM 850MHz Band

No.	Test Conditions		Frequency Deviation (Hz) at Channels Used			
	Voltage	Temperature	128	190	251	Limit (± 0.1 ppm)
1	3.7V	-30°C	-24.34	-24.16	-30.62	(a) ± 82 Hz for 128 Channel (b) ± 84 Hz for 190 Channel (c) ± 85 Hz for 251 Channel
2		-20°C	-34.45	-28.14	-21.79	
3		-10°C	-12.86	11.37	-12.24	
4		0°C	34.42	-31.25	-33.52	
5		+10°C	-25.35	-32.57	-20.24	
6		+20°C	20.35	-24.50	-27.83	
7		+30°C	-30.10	-20.37	-31.43	
8		+40°C	-22.54	-25.22	-40.85	
9		+50°C	-34.26	41.15	-44.58	
10	4.2V	+22°C	-29.13	-22.16	-29.74	
11	3.6V	+22°C	24.52	-27.82	-21.63	

Result: PASS

II PCS 1900MHz Band

No.	Test Conditions		Frequency Deviation (Hz) at Channels Used			
	Voltage	Temperature	512	661	810	Limit (± 0.1 ppm)
1	3.7V	-30°C	-80.13	-60.64	-59.23	(a) ± 185 Hz at 512 Channel (b) ± 188 Hz at 661 Channel (c) ± 191 Hz at 810 Channel
2		-20°C	-60.25	-59.32	-65.29	
3		-10°C	-48.87	-40.61	-56.26	
4		0°C	-30.56	40.25	-26.48	
5		+10°C	-38.11	-30.24	-40.57	
6		+20°C	-21.22	-27.51	-27.89	
7		+30°C	-45.63	35.03	-56.47	
8		+40°C	-55.81	-65.46	-60.78	
9		+50°C	84.26	-84.19	57.25	
10	4.2V	+22°C	-28.56	-36.49	-47.23	
11	3.6V	+22°C	-57.21	-49.26	-58.54	

Result: PASS

I Photograph of the test setup

1. Mains Terminal Disturbance Voltage Measurement



2. Radiated Field Strength Measurement

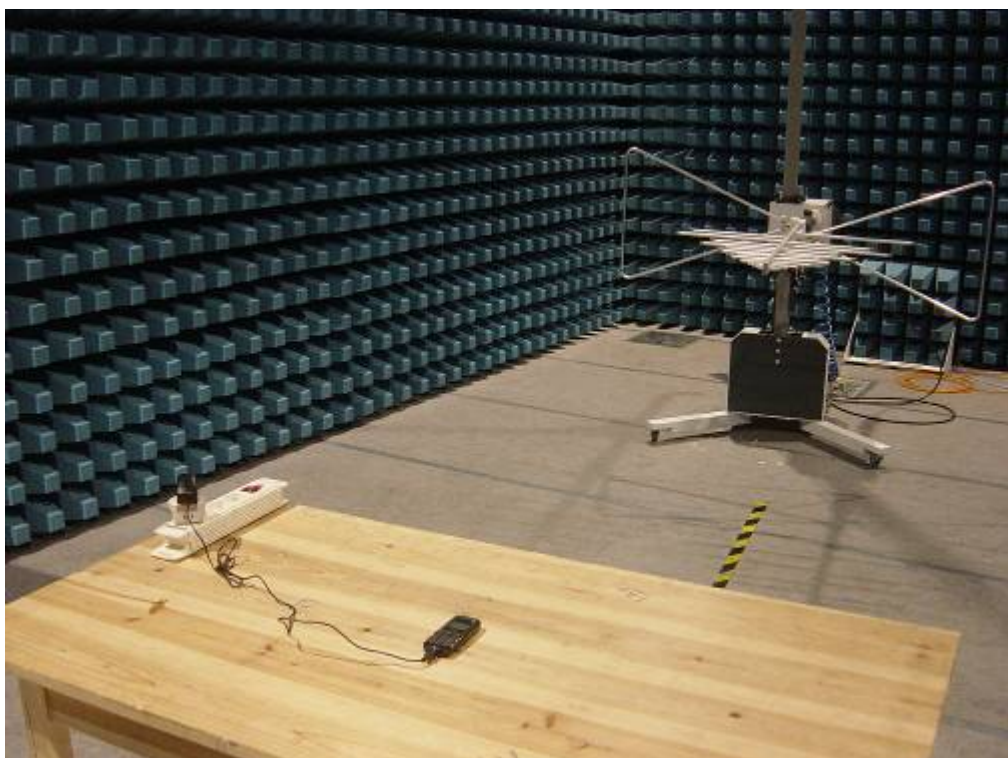

3. Conducted Measurement



4. EIRP/ERP and Spurious Radiation Measurement



II Photograph of the EUT

1. Appearance of the EUT







2. Inside of the EUT



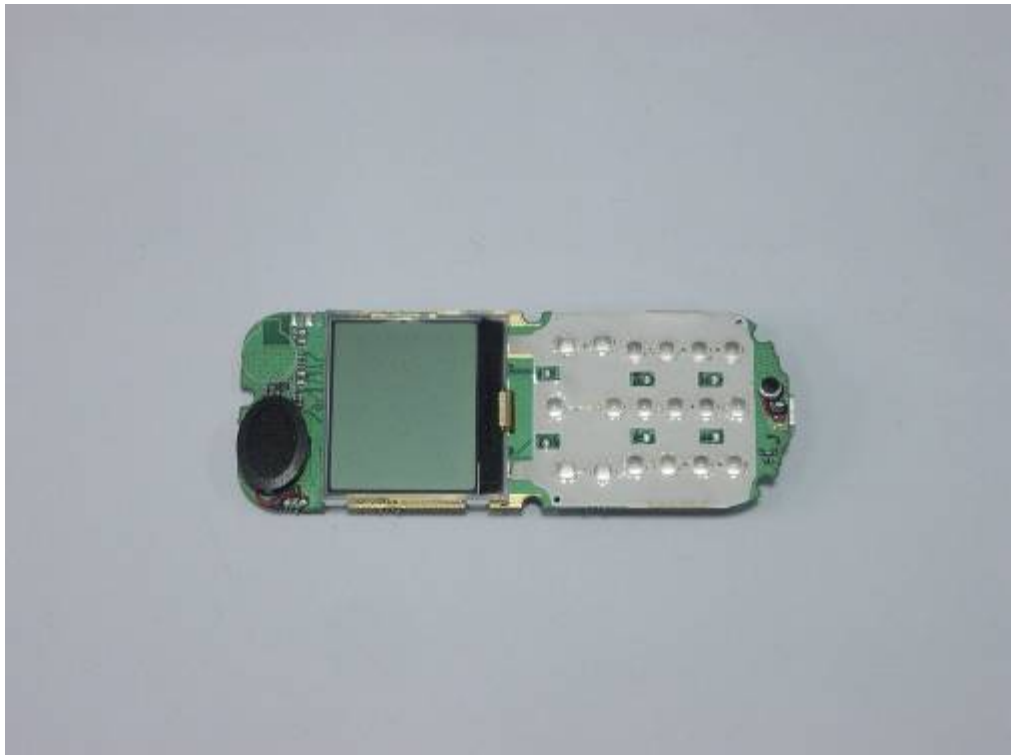

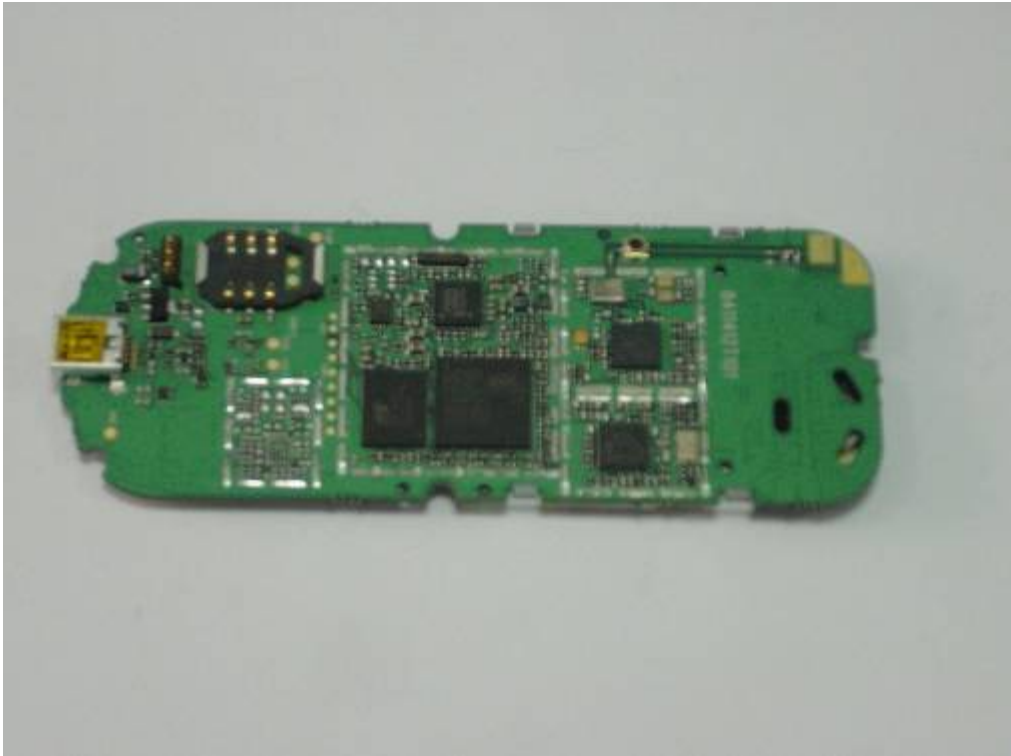
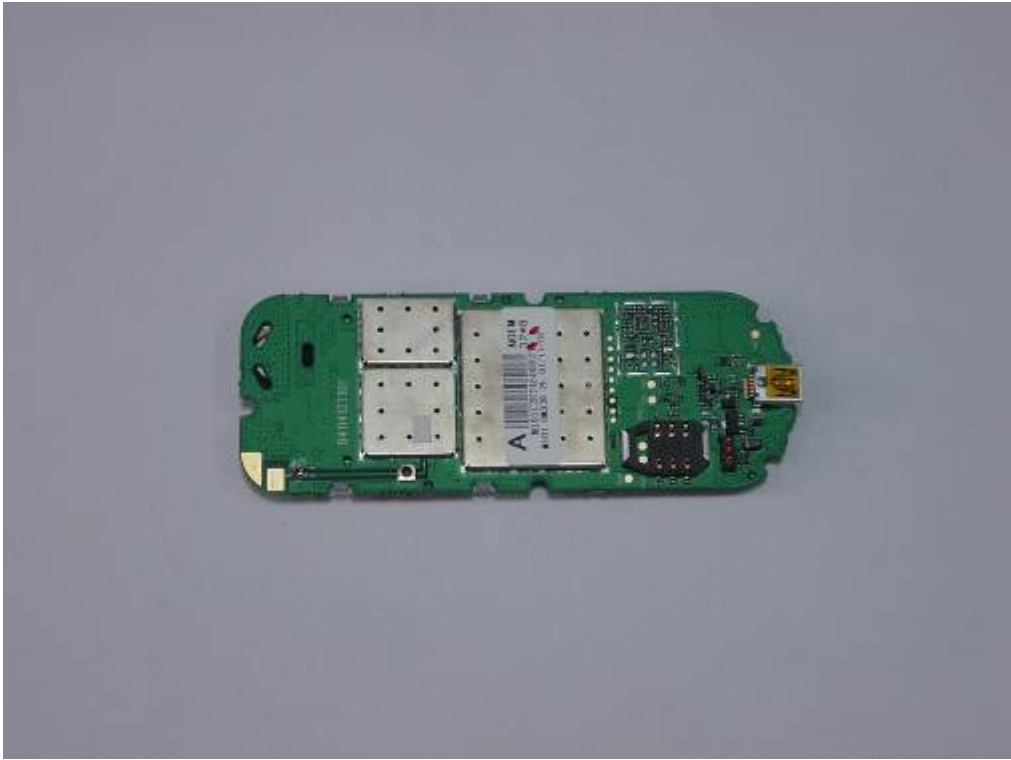

3. Appearance of the headset



4. Appearance of the Adapter

