



FCC RF Test Report

APPLICANT : Communication PL Haier Group
EQUIPMENT : PDA
BRAND NAME : Haier
MODEL NAME : HW-W300
FCC ID : SG70619HW-W300
STANDARD : FCC Part 15 Subpart C §15.247
CLASSIFICATION : (DSS) Spread Spectrum Transmitter

The product was received on Jun. 04, 2012 and completely tested on Jun. 30, 2012. We, SPORTON INTERNATIONAL (KUNSHAN) INC., would like to declare that the tested sample has been evaluated in accordance with the procedures and shown the compliance with the applicable technical standards.

The test results in this report apply exclusively to the tested model / sample. Without written approval of SPORTON INTERNATIONAL (KUNSHAN) INC., the test report shall not be reproduced except in full.

Reviewed by:

Jones Tsai / Manager



SPORTON INTERNATIONAL (KUNSHAN) INC.
No. 3-2, PingXiang Road, Kunshan, Jiangsu Province, P.R.C.



TABLE OF CONTENTS

REVISION HISTORY..... 3

SUMMARY OF TEST RESULT 4

1 GENERAL DESCRIPTION..... 5

 1.1 Applicant 5

 1.2 Manufacturer..... 5

 1.3 Feature of Equipment Under Test 5

 1.4 Testing Site 6

 1.5 Applied Standards 6

 1.6 Ancillary Equipment List 7

2 TEST CONFIGURATION OF EQUIPMENT UNDER TEST..... 8

 2.1 RF Output Power 8

 2.2 Test Mode..... 9

 2.3 Connection Diagram of Test System..... 10

 2.4 RF Utility 11

3 TEST RESULT 12

 3.1 Number of Channel Measurement 12

 3.2 Hopping Channel Separation Measurement 14

 3.3 Dwell Time Measurement..... 17

 3.4 20dB Bandwidth Measurement 19

 3.5 Peak Output Power Measurement 26

 3.6 Conducted Band Edges Measurement 29

 3.7 Conducted Spurious Emission Measurement 31

 3.8 Radiated Band Edges Measurement..... 35

 3.9 Radiated Spurious Emission Measurement 45

 3.10 AC Conducted Emission Measurement..... 55

 3.11 Antenna Requirements..... 60

4 LIST OF MEASURING EQUIPMENT..... 61

5 UNCERTAINTY OF EVALUATION..... 62

APPENDIX A. PHOTOGRAPHS OF EUT

APPENDIX B. SETUP PHOTOGRAPHS

SUMMARY OF TEST RESULT

Report Section	FCC Rule	IC Rule	Description	Limit	Result	Remark
3.1	15.247(a)(1)	A8.4(2)	Number of Channels	≥ 15Chs	Pass	-
3.2	15.247(a)(1)	A8.1(b)	Hopping Channel Separation	≥ 2/3 of 20dB BW	Pass	-
3.3	15.247(a)(1)	A8.1(d)	Dwell Time of Each Channel	≤ 0.4sec in 31.6sec period	Pass	-
3.4	15.247(a)(1)	A8.1(a)	20dB Bandwidth	NA	Pass	-
3.5	15.247(b)(1)	A8.1(b)	Peak Output Power	≤ 125 mW	Pass	-
3.6	15.247(d)	A8.5	Conducted Band Edges	≤ 20dBc	Pass	-
3.7	15.247(d)	A8.5	Conducted Spurious Emission	≤ 20dBc	Pass	-
3.8	15.247(d)	A8.5	Radiated Band Edges	15.209(a) & 15.247(d)	Pass	-
3.9	15.247(d)	A8.5	Radiated Spurious Emission	15.209(a) & 15.247(d)	Pass	Under limit 6.83 dB at 103.720 MHz
3.10	15.207	Gen 7.2.4	AC Conducted Emission	15.207(a)	Pass	Under limit 10.14 dB at 0.700 MHz
3.11	15.203 & 15.247(b)	A8.4	Antenna Requirement	N/A	Pass	-

1 General Description

1.1 Applicant

Communication PL Haier Group

No.1 Haier Road, Hi-tech Zone, Qingdao 266101, PR.China

1.2 Manufacturer

Communication PL Haier Group

No.1 Haier Road, Hi-tech Zone, Qingdao 266101, PR.China

1.3 Feature of Equipment Under Test

Product Feature	
Equipment	PDA
Brand Name	Haier
Model Name	HW-W300
FCC ID	SG70619HW-W300
EUT supports Radios application	GSM/WCDMA/Bluetooth
HW Version	Z90_MB_H301_PBF
SW Version	HW-W300-H01-S017-TIGO-20120529
EUT Stage	Identical Prototype

Remark: The above EUT's information was declared by manufacturer. Please refer to the specifications or user's manual for more detailed description.

Product Specification subjective to this standard	
Tx/Rx Frequency Range	2402 MHz ~ 2480 MHz
Number of Channels	79
Carrier Frequency of Each Channel	2402+n*1 MHz; n=0~78
Maximum Output Power to Antenna	Bluetooth (1Mbps) : -2.66 dBm (0.00054 W) Bluetooth EDR (2Mbps) : -2.93 dBm (0.00051 W) Bluetooth EDR (3Mbps) : -2.78 dBm (0.00053 W)
99% Occupied Bandwidth	Bluetooth (1Mbps) : 0.8640MHz Bluetooth EDR (2Mbps) : 1.1600MHz Bluetooth EDR (3Mbps) : 1.1680MHz
Antenna Type	Dipole Antenna with gain -1 dBi
Type of Modulation	Bluetooth (1Mbps) : GFSK Bluetooth 2.1 EDR (2Mbps) : π /4-DQPSK Bluetooth 2.1 EDR (3Mbps) : 8-DPSK

1.4 Testing Site

Test Site	SPORTON INTERNATIONAL (KUNSHAN) INC.			
Test Site Location	No. 3-2, PingXiang Road, Kunshan, Jiangsu Province, P.R.C. TEL: +86-0512-5790-0158 FAX: +86-0512-5790-0958			
Test Site No.	Sporton Site No.			FCC/IC Registration No.
	TH01-KS	CO01-KS	03CH01-KS	149928/4086E-1

1.5 Applied Standards

According to the specifications of the manufacturer, the EUT must comply with the requirements of the following standards:

- ♦ FCC Part 15 Subpart C §15.247
- ♦ FCC Public Notice DA 00-705
- ♦ ANSI C63.4-2003 and ANSI C63.10-2009
- ♦ IC RSS-210 Issue 8
- ♦ IC RSS-Gen Issue 3

Remark:

1. All test items were verified and recorded according to the standards and without any deviation during the test.
2. This EUT has also been tested and complied with the requirements of FCC Part 15, Subpart B, recorded in a separate test report.



1.6 Ancillary Equipment List

Item	Equipment	Trade Name	Model Name	FCC ID	Data Cable	Power Cord
1.	System Simulator	R&S	CMU 200	N/A	N/A	Unshielded, 1.8 m
2.	Bluetooth Earphone	Nokia	BH-106	QTLBH-106	N/A	N/A
3.	Bluetooth Base Station	R&S	CBT	N/A	N/A	Unshielded,1.8m
4.	DC Power Supply	GWINSTEK	GPS-3030D	N/A	N/A	Unshielded, 1.8 m

2 Test Configuration of Equipment Under Test

2.1 RF Output Power

Preliminary tests were performed in different data rate and recorded the RF output power in the following table:

Band	Bluetooth RF Output Power		
Channel	00	39	78
Frequency	2402	2441	2480
Peak Power	-2.66	-3.45	-3.00

Remark:

1. All the test data for each data rate were verified, but only the worst case was reported.
2. The data rate was set in 1Mbps for all the test items due to the highest RF output power.
3. The EUT is programmed to transmit signals continuously for all testing.

2.2 Test Mode

The EUT has been associated with peripherals pursuant to ANSI C63.4-2003 and ANSI C63.10-2009 and configuration operated in a manner tended to maximize its emission characteristics in a typical application. Frequency range investigated: conduction (150 KHz to 30 MHz), radiation (9 KHz to the 10th harmonic of the highest fundamental frequency or to 40 GHz, whichever is lower).

Pre-scanned tests, X, Y, Z in three orthogonal panels, were conducted to determine the final configuration from all possible combinations.

The following tables are showing the test modes as the worst cases (X plane) and recorded in this report.

Test Cases			
Test Item	Data Rate / Modulation		
	Bluetooth 1Mbps GFSK	Bluetooth EDR 2Mbps $\pi/4$ -DQPSK	Bluetooth EDR 3Mbps 8-DPSK
Conducted TCs	Mode 1: CH00_2402 MHz Mode 2: CH39_2441 MHz Mode 3: CH78_2480 MHz	Mode 4: CH00_2402 MHz Mode 5: CH39_2441 MHz Mode 6: CH78_2480 MHz	Mode 7: CH00_2402 MHz Mode 8: CH39_2441 MHz Mode 9: CH78_2480 MHz
Radiated TCs	Mode 1: CH00_2402 MHz Mode 2: CH39_2441 MHz Mode 3: CH78_2480 MHz	N/A	N/A
AC Conducted Emission	Mode 1 :GSM850 Idle + Bluetooth Link + Adapter + Earphone + Camera		
Remark: For radiated TCs, the data rate was set in 1Mbps due to the highest RF output power; only the data of these modes was reported.			

2.3 Connection Diagram of Test System

<Bluetooth Tx Mode>

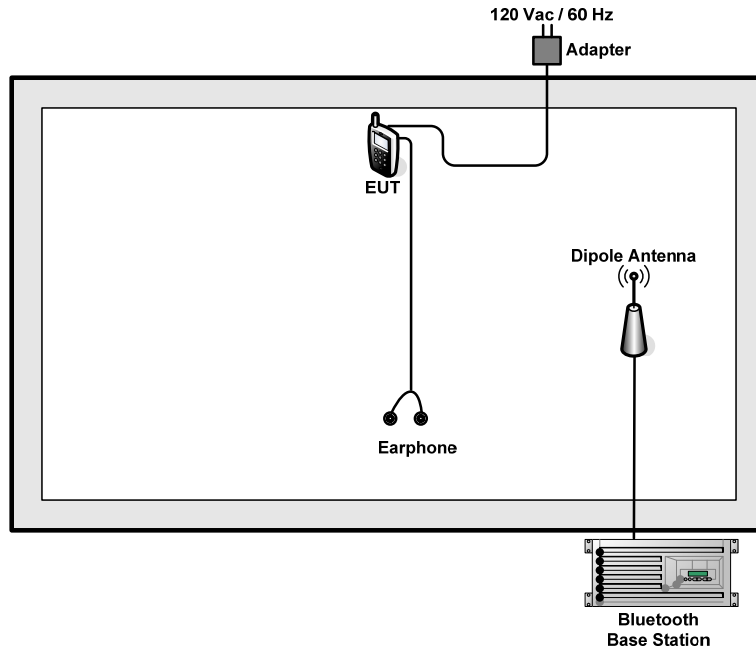

<AC Conducted Emission Mode>

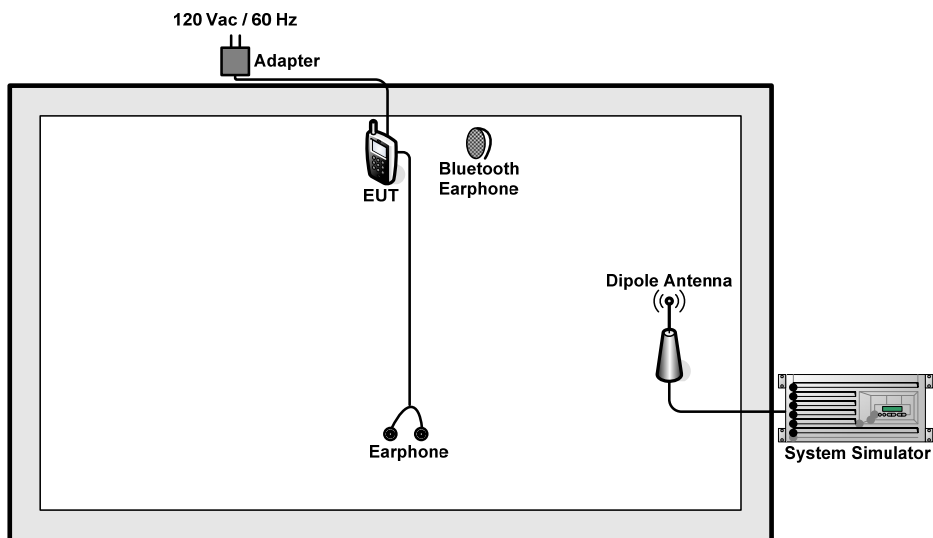



2.4 RF Utility

For Bluetooth function, key in “* #6001 #” on the EUT directly. Then, the EUT will get into the engineering modes to contact with Bluetooth base station for continuous transmitting and receiving signals.

3 Test Result

3.1 Number of Channel Measurement

3.1.1 Limits of Number of Hopping Frequency

Frequency hopping systems in the 2400-2483.5 MHz band shall use at least 15 channels.

3.1.2 Measuring Instruments

See list of measuring instruments of this test report.

3.1.3 Test Procedure

1. The testing follows FCC Public Notice DA 00-705 Measurement Guidelines.
2. The RF output of EUT was connected to the spectrum analyzer by a low loss cable.
3. The modulation types of EUT are irrelevant to number of hopping channels deviation.
The EUT must have its hopping function enabled. Use the following spectrum analyzer settings:
Span = the frequency band of operation; RBW \geq 1% of the span; VBW \geq RBW; Sweep = auto;
Detector function = peak; Trace = max hold.
4. The number of hopping frequency used is defined as the device has the numbers of total channel.

3.1.4 Test Setup

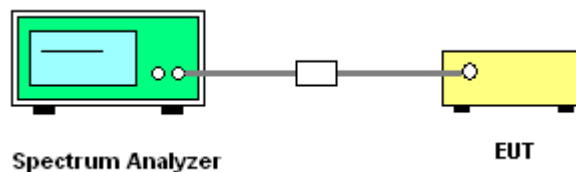

3.1.5 Test Result of Number of Hopping Frequency

Test Mode :	1Mbps	Temperature :	23~24°C
Test Engineer :	Lizy Li	Relative Humidity :	47~48%
Number of Hopping Channels (Channel)		Limits (Channel)	Pass/Fail
79		> 15	Pass



Number of Hopping Channel Plot on Channel 00 - 78

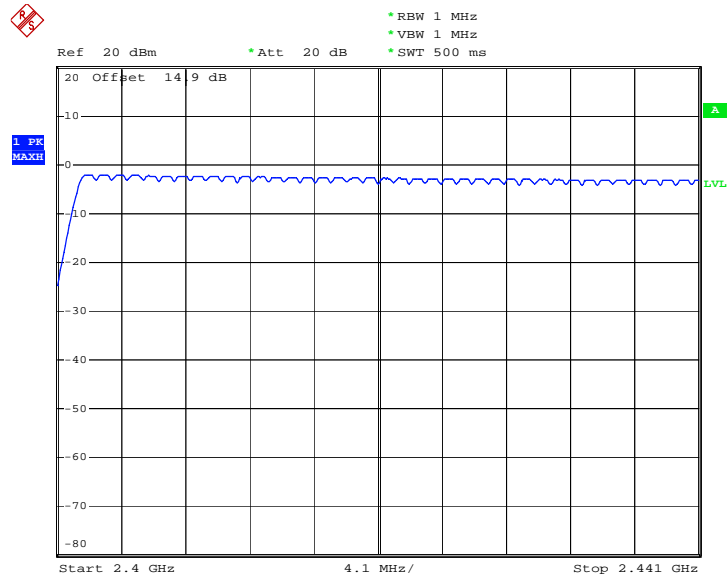

Date: 14.JUN.2012 21:02:10

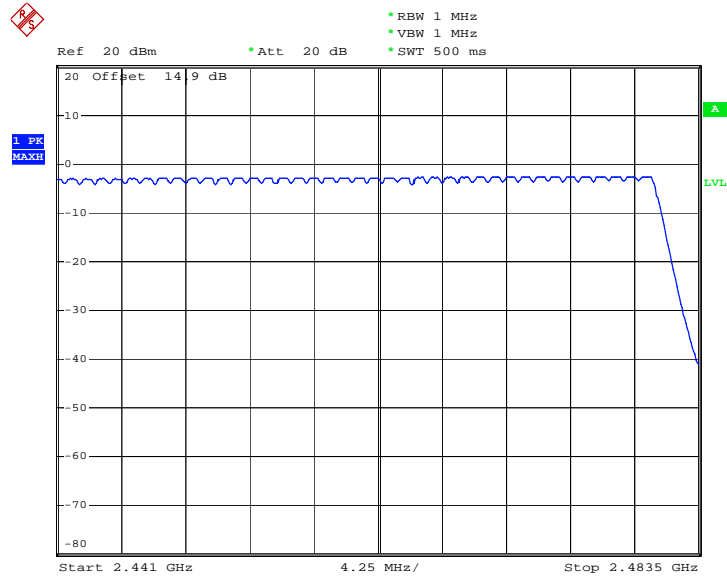

Date: 14.JUN.2012 21:05:08

3.2 Hopping Channel Separation Measurement

3.2.1 Limit of Hopping Channel Separation

Frequency hopping systems operating in the 2400-2483.5 MHz band may have hopping channel carrier frequencies that are separated by 25 KHz or two-thirds of the 20 dB bandwidth of the hopping channel, whichever is greater.

3.2.2 Measuring Instruments

See list of measuring instruments of this test report.

3.2.3 Test Procedures

1. Please refer FCC Public Notice DA 00-705 Measurement Guidelines.
2. The RF output of EUT was connected to the spectrum analyzer by a low loss cable.
3. The EUT should be transmitting at its maximum data rate as the worst cases.
4. Use the following spectrum analyzer settings:
Span = wide enough to capture the peaks of two adjacent channels; $RBW \geq 1\%$ of the span;
VBW \geq RBW; Sweep = auto; Detector function = peak; Trace = max hold.
5. Use the marker-delta function to determine the separation between the peaks of the adjacent channels.

3.2.4 Test Setup

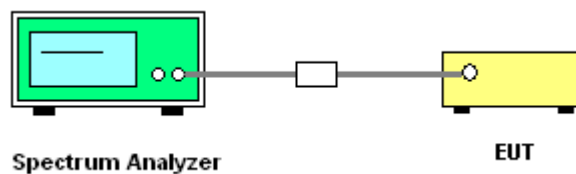

3.2.5 Test Result of Hopping Channel Separation

Test Mode :	1Mbps	Temperature :	23~24°C
Test Engineer :	Lizy Li	Relative Humidity :	47~48%

Channel	Frequency (MHz)	Frequency Separation (MHz)	(2/3 of 20dB BW) Limits (MHz)	Pass/Fail
00	2402	1.008	0.6267	Pass
39	2441	1.002	0.6267	Pass
78	2480	1.002	0.5707	Pass

Channel Separation Plot on Channel 00 - 01

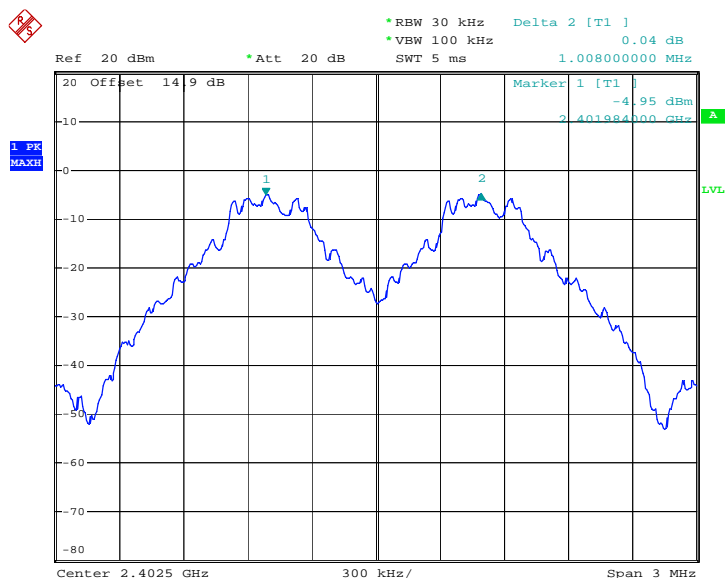

Date: 14.JUN.2012 20:31:25



Channel Separation Plot on Channel 39 - 40

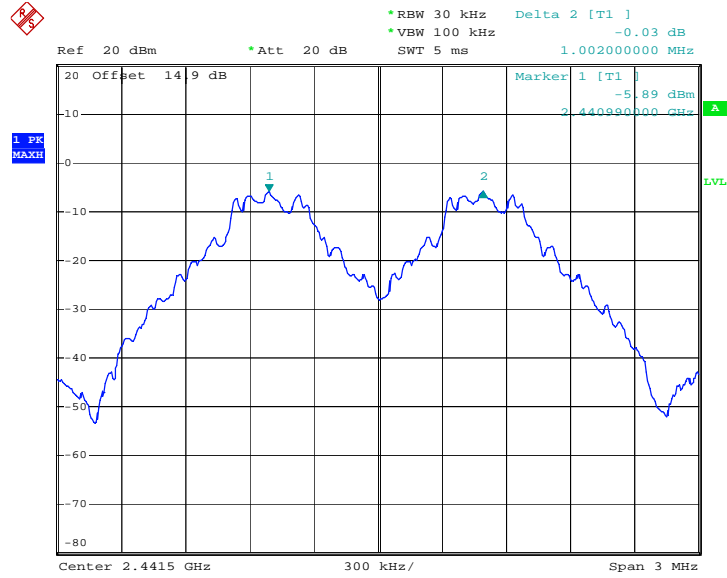

Date: 14.JUN.2012 20:32:05

Channel Separation Plot on Channel 77 - 78

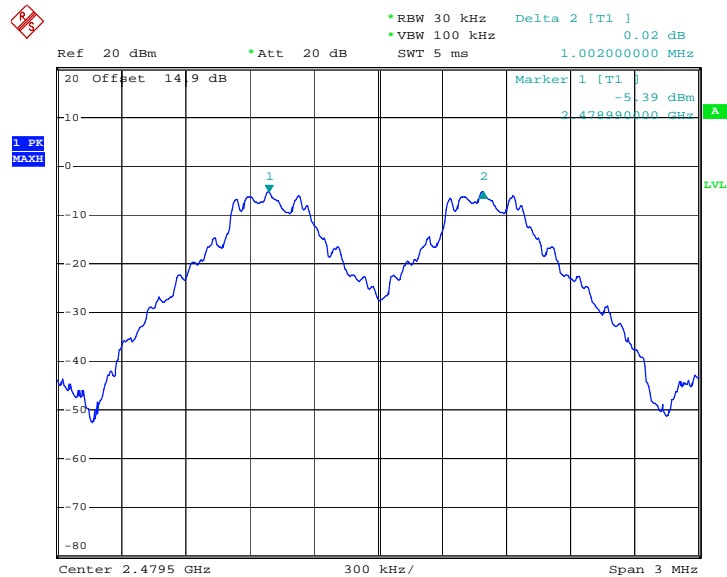

Date: 14.JUN.2012 20:32:45

3.3 Dwell Time Measurement

3.3.1 Limit of Dwell Time

The average time of occupancy on any channel shall not be greater than 0.4 seconds within a period of 0.4 seconds multiplied by the number of hopping channels employed.

3.3.2 Measuring Instruments

See list of measuring instruments of this test report.

3.3.3 Test Procedures

1. The testing follows FCC Public Notice DA 00-705 Measurement Guidelines.
2. The RF output of EUT was connected to the spectrum analyzer by a low loss cable.
3. The EUT should be transmitting at its maximum data rate as the worst cases.
4. The EUT must have its hopping function enabled. Use the following spectrum analyzer settings:
Span = zero span, centered on a hopping channel; RBW = 1 MHz; VBW ≥ RBW; Sweep = as necessary to capture the entire dwell time per hopping channel; Detector function = peak; Trace = max hold.
5. Use the marker-delta function to calculate the dwell time.

3.3.4 Test Setup

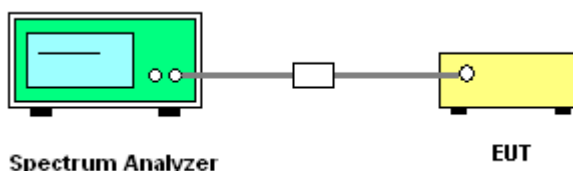

3.3.5 Test Result of Dwell Time

Test Mode :	DH5	Temperature :	23~24°C
Test Engineer :	Lizy Li	Relative Humidity :	47~48%

Package Mode	Average Hopping Channel	Package Transfer Time (usec)	Dwell Time (sec)	Limits (sec)	Pass/Fail
DH5	3.60	2946.00	0.34	0.4	Pass

Remark:

1. Dwell Time=79(channels) x 0.4(s) x average hopping channel x package transfer time
2. 79 channels come from the Hopping Channel number.
3. Average Hopping Channel = hops/sweep time
4. T: Package Transfer Time(us)



DH5 Dwell Time (One Pulse) Plot on Channel 39

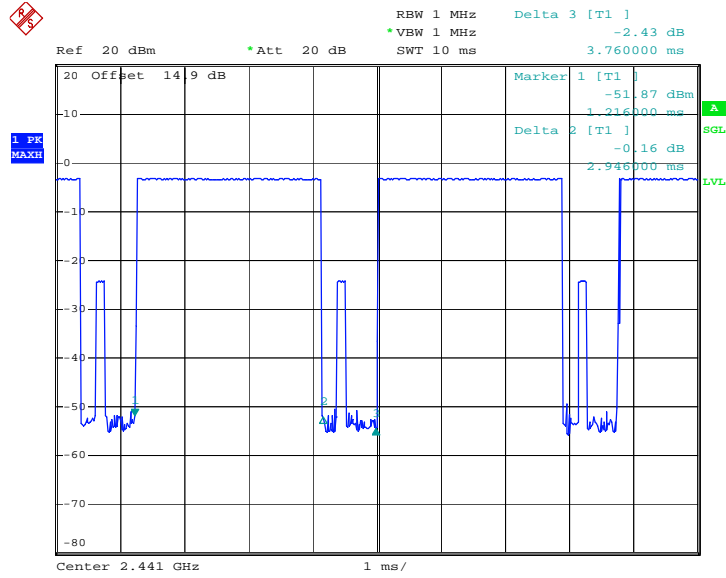

Date: 14.JUN.2012 20:27:59

DH5 Dwell Time (Count Pulses) Plot on Channel 39

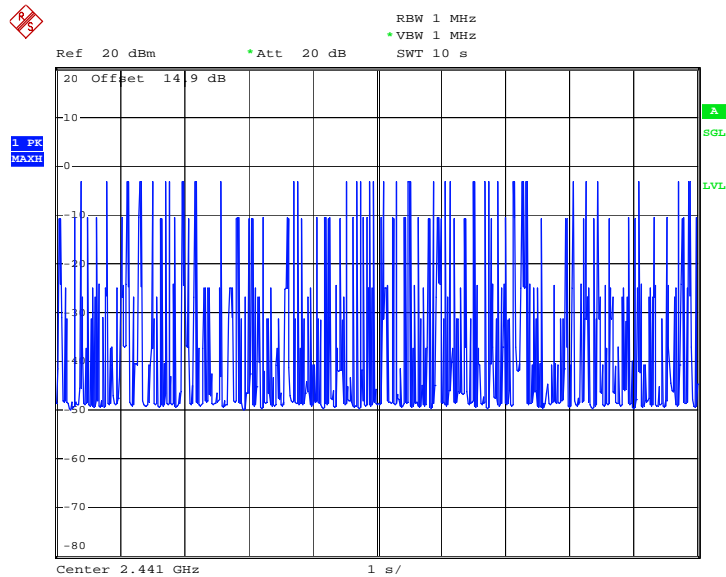

Date: 14.JUN.2012 20:39:20

3.4 20dB Bandwidth Measurement

3.4.1 Limit of 20dB Bandwidth

N/A

3.4.2 Measuring Instruments

See list of measuring instruments of this test report.

3.4.3 Test Procedures

1. The testing follows FCC Public Notice DA 00-705 Measurement Guidelines.
2. The RF output of EUT was connected to the spectrum analyzer by a low loss cable.
3. The EUT should be transmitting at its maximum data rate as the worst cases.
4. Use the following spectrum analyzer settings:
Span = approximately 2 to 3 times the 20 dB bandwidth, centered on a hopping channel;
RBW \geq 1% of the 20 dB bandwidth; VBW \geq RBW; Sweep = auto; Detector function = peak;
Trace = max hold.
5. The marker-delta reading at this point is the 20 dB bandwidth of the emission.

3.4.4 Test Setup

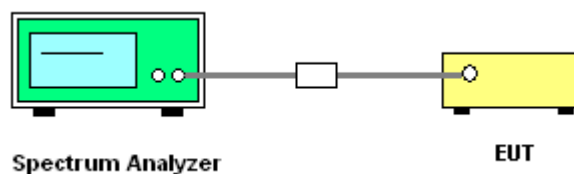

3.4.5 Test Result of 20dB Bandwidth

Test Mode :	1Mbps	Temperature :	23~24°C
Test Engineer :	Lizy Li	Relative Humidity :	47~48%

Channel	Frequency (MHz)	20dB Bandwidth (MHz)
00	2402	0.940
39	2441	0.940
78	2480	0.856

20 dB Bandwidth Plot on Channel 00

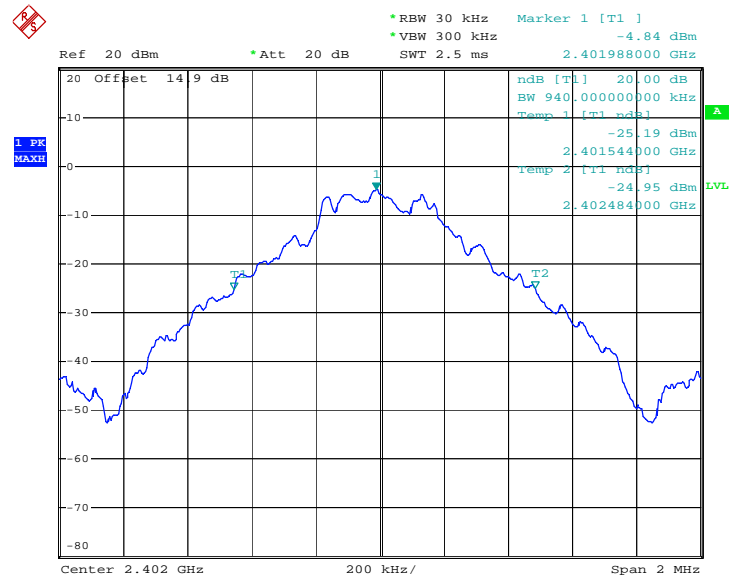

Date: 14.JUN.2012 20:41:04



20 dB Bandwidth Plot on Channel 39

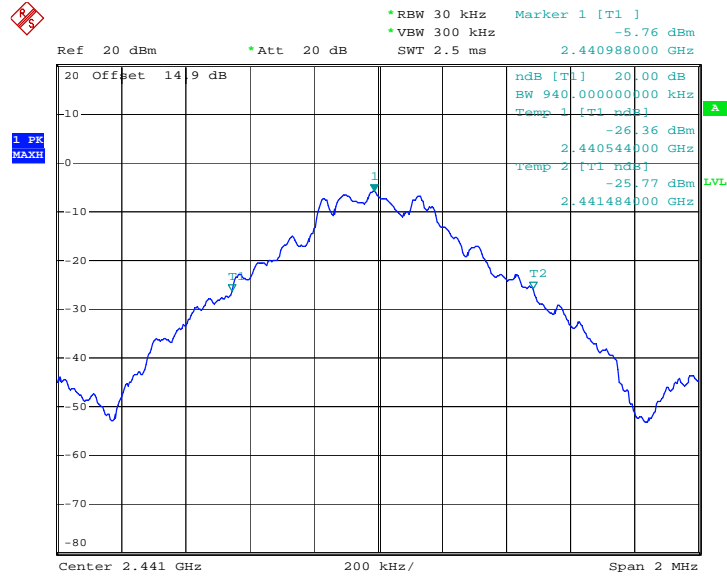

Date: 14.JUN.2012 20:41:14

20 dB Bandwidth Plot on Channel 78

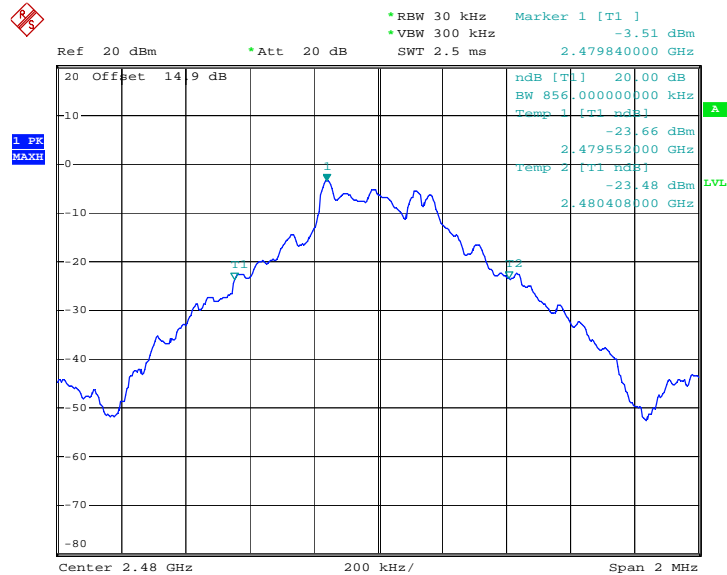

Date: 14.JUN.2012 20:41:25



Test Mode :	2Mbps	Temperature :	23~24°C
Test Engineer :	Lizy Li	Relative Humidity :	47~48%

Channel	Frequency (MHz)	20dB Bandwidth (MHz)
00	2402	1.266
39	2441	1.266
78	2480	1.224

20 dB Bandwidth Plot on Channel 00

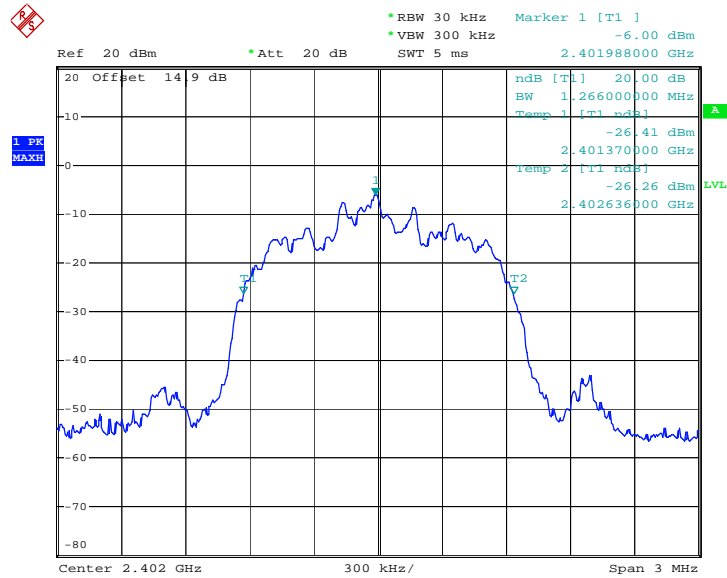

Date: 14.JUN.2012 20:41:36



20 dB Bandwidth Plot on Channel 39

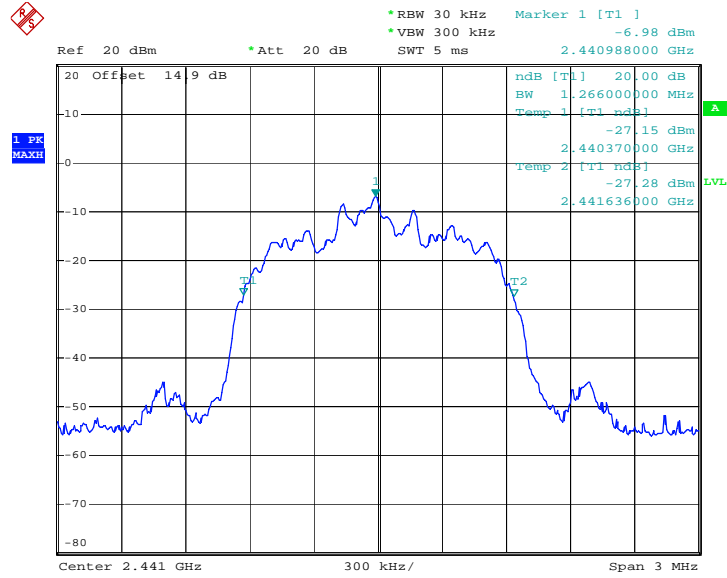

Date: 14.JUN.2012 20:41:49

20 dB Bandwidth Plot on Channel 78

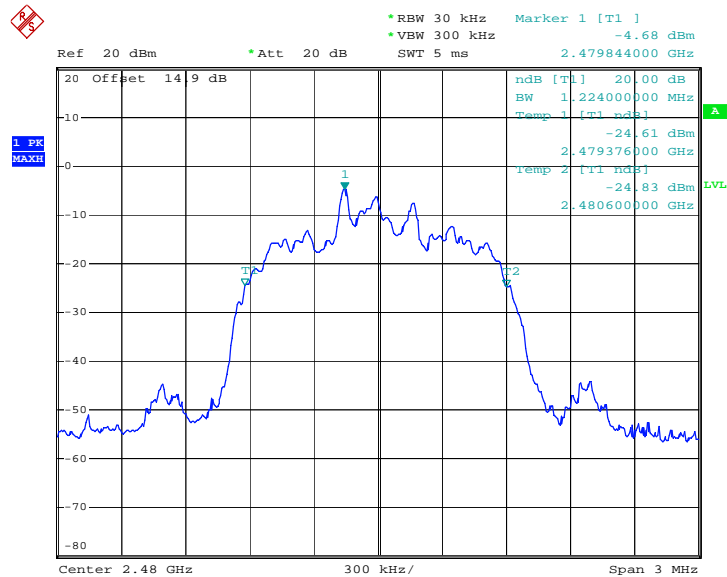

Date: 14.JUN.2012 20:42:01



Test Mode :	3Mbps	Temperature :	23~24°C
Test Engineer :	Lizy Li	Relative Humidity :	47~48%

Channel	Frequency (MHz)	20dB Bandwidth (MHz)
00	2402	1.284
39	2441	1.302
78	2480	1.260

20 dB Bandwidth Plot on Channel 00

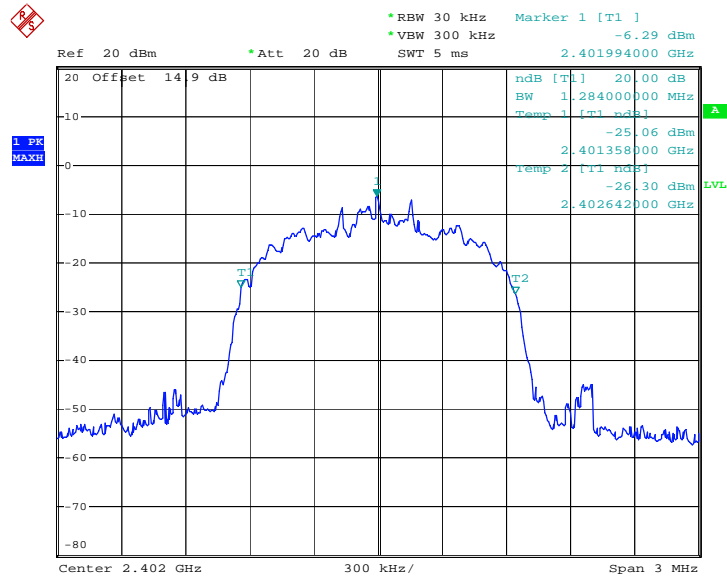

Date: 14.JUN.2012 20:42:07



20 dB Bandwidth Plot on Channel 39

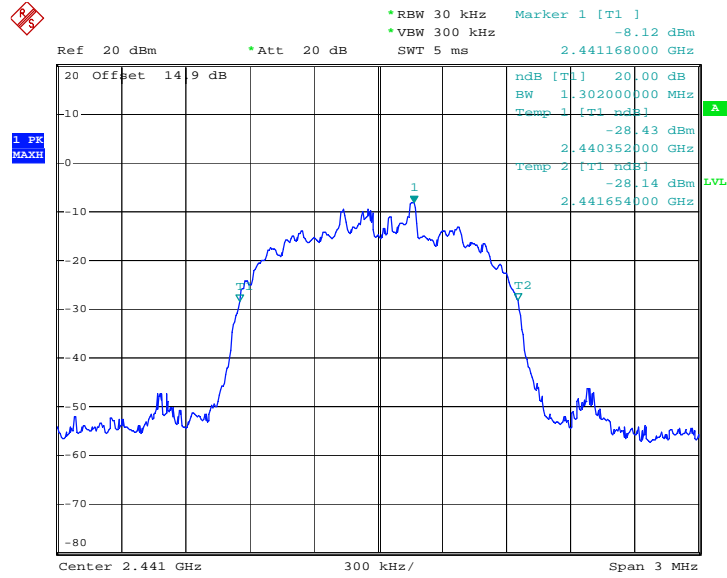

Date: 14.JUN.2012 20:42:12

20 dB Bandwidth Plot on Channel 78

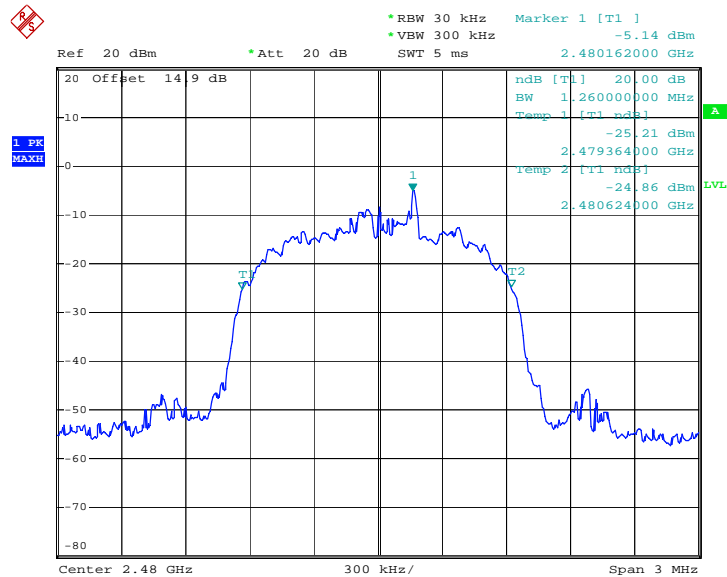

Date: 14.JUN.2012 20:42:18

3.5 Peak Output Power Measurement

3.5.1 Limit of Peak Output Power

Section 15.247 (b) The maximum peak conducted output power of the intentional radiator shall not exceed the following: (1) For frequency hopping systems operating in the 2400-2483.5 MHz band employing at least 75 non-overlapping hopping channels, and all frequency hopping systems in the 5725-5850 MHz band: 1 watt. For all other frequency hopping systems in the 2400-2483.5 MHz band 0.125 watts. The power limit for 1Mbps is 1watt, and for 2Mbps, and 3Mbps are 0.125 watts.

3.5.2 Measuring Instruments

See list of measuring instruments of this test report.

3.5.3 Test Procedures

1. The testing follows FCC Public Notice DA 00-705 Measurement Guidelines.
2. The RF output of EUT was connected to the spectrum analyzer by a low loss cable.

3.5.4 Test Setup

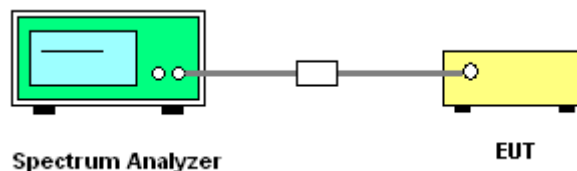

3.5.5 Test Result of Peak Output Power

Test Mode :	1Mbps	Temperature :	23~24°C
Test Engineer :	Lizy Li	Relative Humidity :	47~48%

Channel	Frequency (MHz)	RF Power (dBm)		
		GFSK	Max. Limits (dBm)	Pass/Fail
		1 Mbps		
00	2402	-2.66	30	Pass
39	2441	-3.45	30	Pass
78	2480	-3.00	30	Pass



Peak Output Power Plot on Channel 00

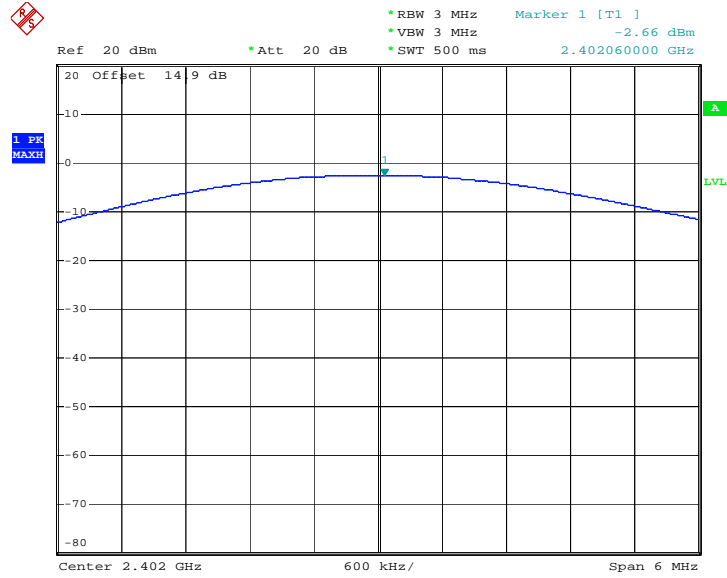

Date: 13.JUN.2012 22:18:04

Peak Output Power Plot on Channel 39

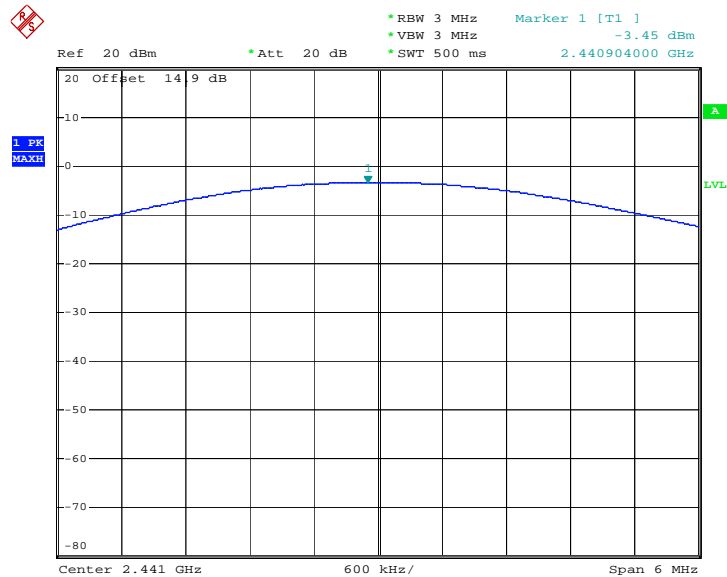

Date: 13.JUN.2012 22:19:19



Peak Output Power Plot on Channel 78

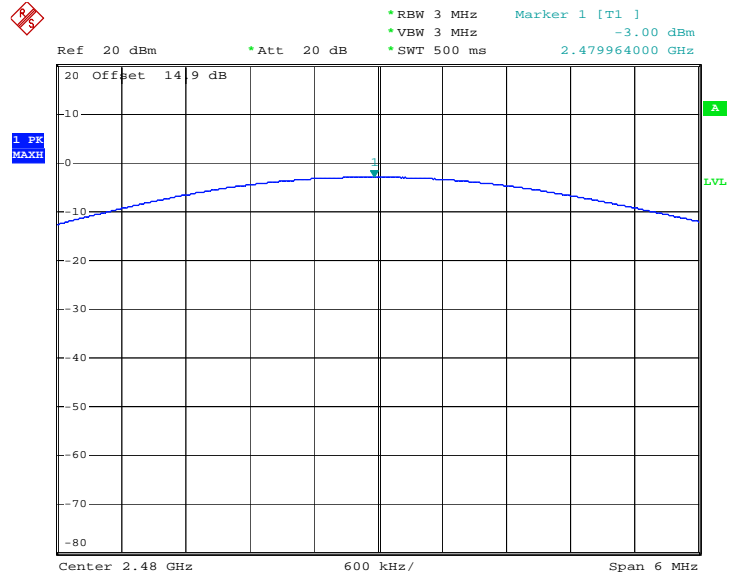

Date: 13.JUN.2012 22:20:35

3.6 Conducted Band Edges Measurement

3.6.1 Limit of Band Edges

In any 100 KHz bandwidth outside the intentional radiation frequency band, the radio frequency power shall be at least 20 dB below the highest level of the radiated power. In addition, radiated emissions which fall in the restricted bands must also comply with the radiated emission limits.

3.6.2 Measuring Instruments

See list of measuring instruments of this test report.

3.6.3 Test Procedures

1. The testing follows the guidelines in Band-edge Compliance of RF Conducted Emissions of FCC Public Notice DA 00-705 Measurement Guidelines.
2. Set RBW = 300KHz ($\geq 1\%$ span=30MHz), VBW = 300KHz (\geq RBW). Band edge emissions must be at least 20 dB down from the highest emission level within the authorized band as measured with a 300k Hz RBW. Note: If the device complies with the use of power option 2 the attenuation under this paragraph shall be 30 dB instead of 20 dB.
3. In case the emission is fail due to the used RBW / VBW is too wide, marker-delta method of FCC Public Notice DA 00-705 will be followed.

3.6.4 Test Setup

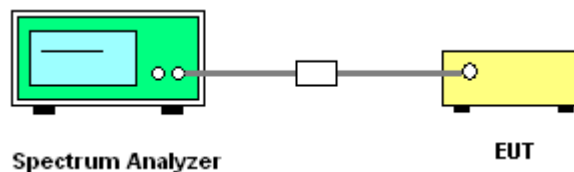



1.6.5 Test Result of Conducted Band Edges

Test Mode :	1Mbps	Temperature :	23~24°C
Test Channel :	00 and 78	Relative Humidity :	47~48%
		Test Engineer :	Lizy Li

Low Band Edge Plot on Channel 00

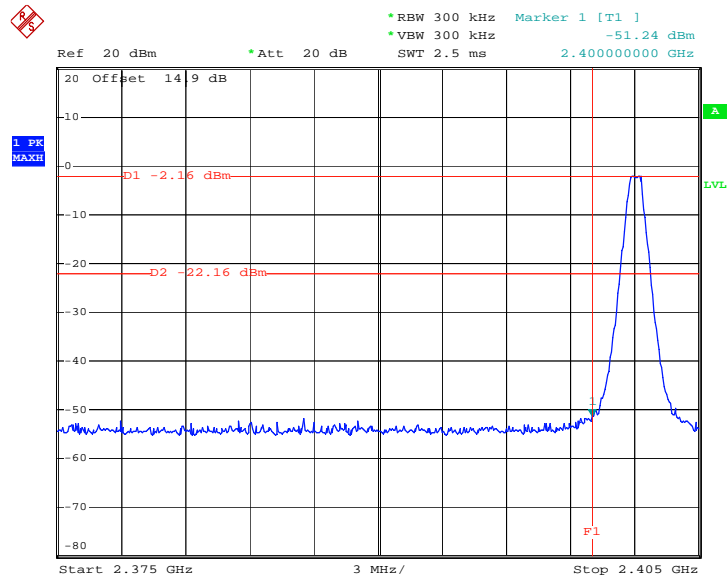

Date: 14.JUN.2012 20:43:13

High Band Edge Plot on Channel 78

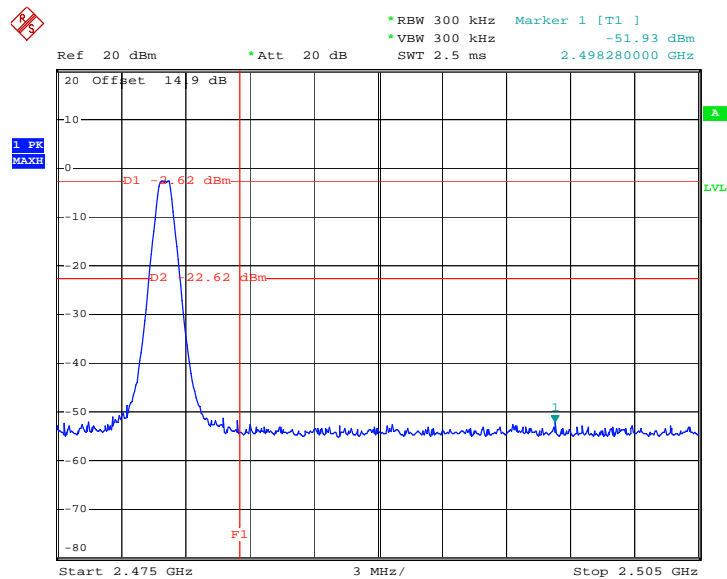

Date: 14.JUN.2012 20:44:16

3.7 Conducted Spurious Emission Measurement

3.7.1 Limit of Spurious Emission Measurement

In any 100 KHz bandwidth outside the intentional radiation frequency band, the radio frequency power shall be at least 20 dB below the highest level of the radiated power. In addition, radiated emissions which fall in the restricted bands must also comply with the radiated emission limits.

3.7.2 Measuring Instruments

See list of measuring instruments of this test report.

3.7.3 Test Procedure

1. The testing follows the guidelines in Spurious RF Conducted Emissions of FCC Public Notice DA 00-705 Measurement Guidelines
2. The transmitter output was connected to the spectrum analyzer via a low lose cable.
3. Set RBW = 100 KHz, VBW = 300KHz, scan up through 10th harmonic. All harmonics / spurs must be at least 20 dB down from the highest emission level within the authorized band as measured with a 100 KHz RBW.

3.7.4 Test Setup

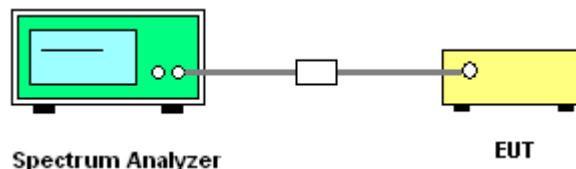



3.7.5 Test Result

Test Mode :	1Mbps	Temperature :	23~24°C
Test Channel :	00	Relative Humidity :	47~48%
		Test Engineer :	Lizy Li

Conducted Spurious Emission Plot between 30MHz ~ 3 GHz

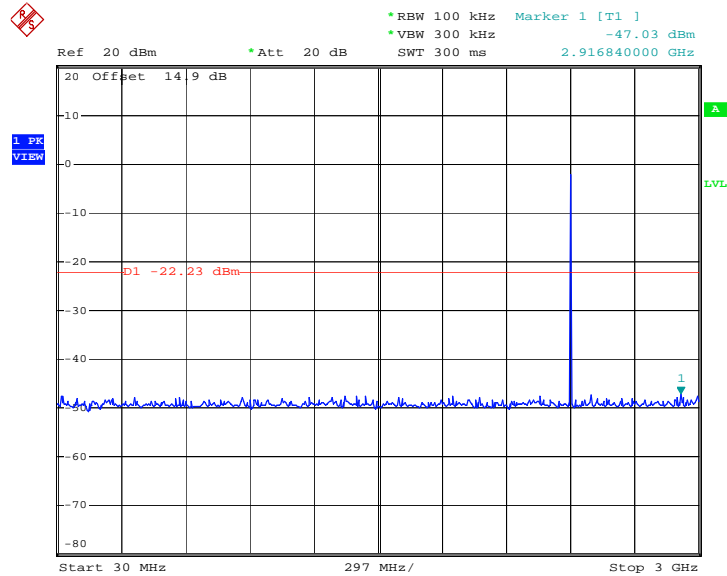

Date: 14.JUN.2012 20:54:25

Conducted Spurious Emission Plot between 3 GHz ~ 25 GHz

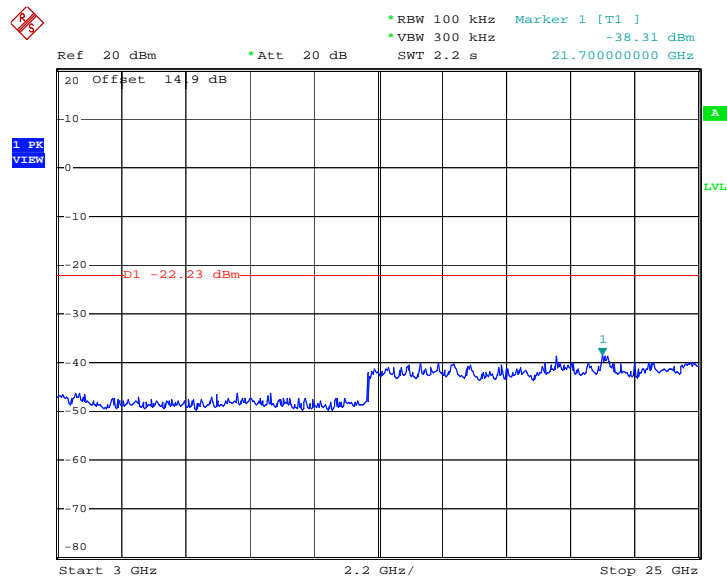

Date: 14.JUN.2012 20:54:37



Test Mode :	1Mbps	Temperature :	23~24°C
Test Channel :	39	Relative Humidity :	47~48%
		Test Engineer :	Lizy Li

Conducted Spurious Emission Plot between 30MHz ~ 3 GHz

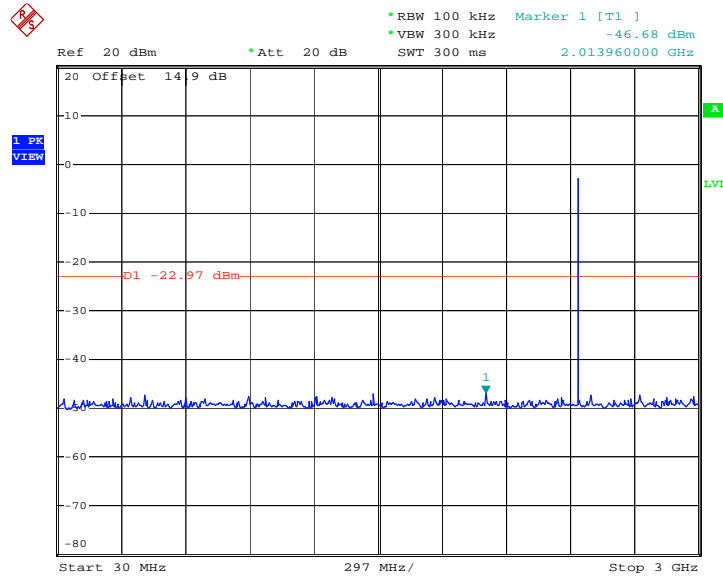

Date: 14.JUN.2012 20:55:29

Conducted Spurious Emission Plot between 3 GHz ~ 25 GHz

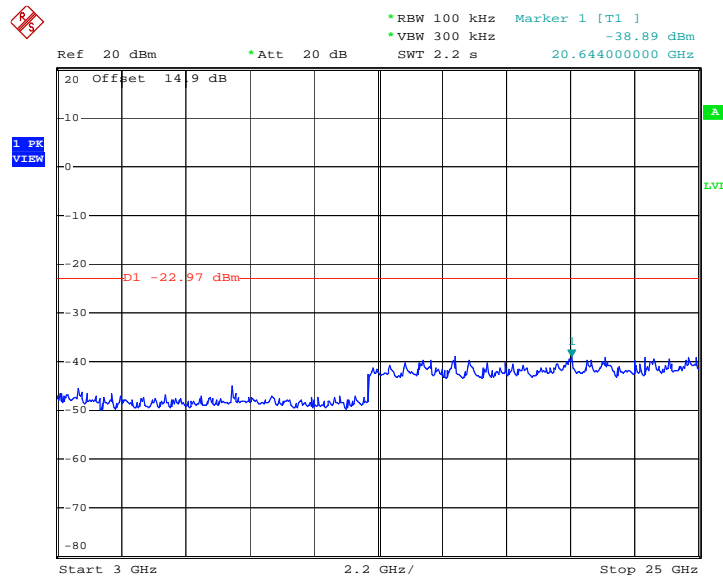

Date: 14.JUN.2012 20:55:41



Test Mode :	1Mbps	Temperature :	23~24°C
Test Channel :	78	Relative Humidity :	47~48%
		Test Engineer :	Lizy Li

Conducted Spurious Emission Plot between 30MHz ~ 3 GHz

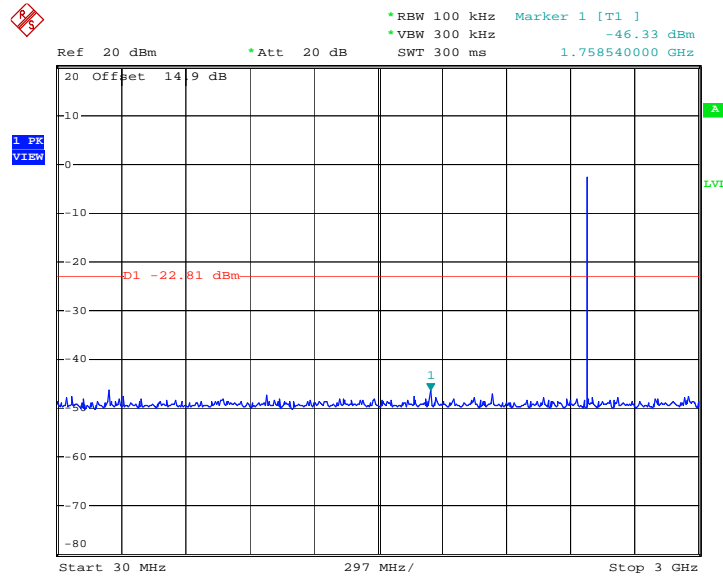

Date: 14.JUN.2012 20:56:33

Conducted Spurious Emission Plot between 3 GHz ~ 25 GHz

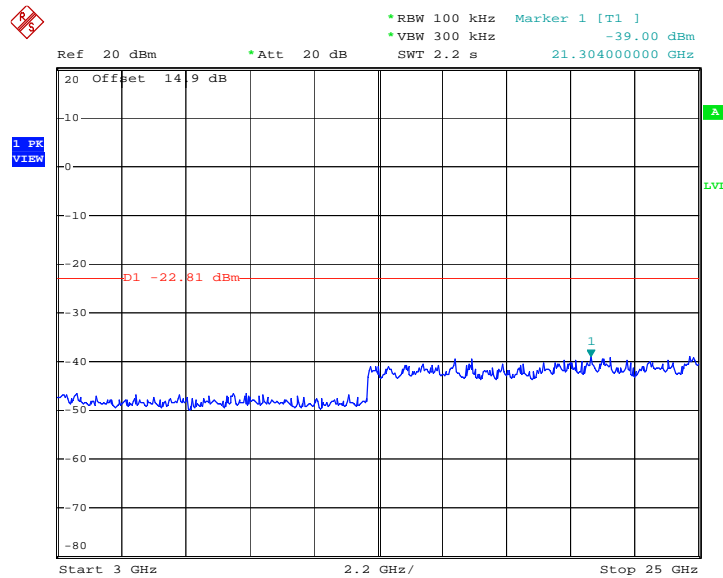

Date: 14.JUN.2012 20:56:45

3.8 Radiated Band Edges Measurement

3.8.1 Limit of Radiated Band Edges

In any 100 KHz bandwidth outside the intentional radiator frequency band, all harmonics/spurious must be at least 20 dB below the highest emission level within the authorized band. In addition, radiated emissions which fall in the restricted bands must also comply with the FCC section 15.209 limits as below.

Frequency (MHz)	Field Strength (microvolts/meter)	Measurement Distance (meters)
0.009 – 0.490	2400/F(KHz)	300
0.490 – 1.705	24000/F(KHz)	30
1.705 – 30.0	30	30
30 – 88	100	3
88 – 216	150	3
216 - 960	200	3
Above 960	500	3

3.8.2 Measuring Instruments

See list of measuring instruments of this test report.

3.8.3 Test Procedures

1. The testing follows the guidelines in Spurious Radiated Emissions of FCC Public Notice DA 00-705 Measurement Guidelines and fulfills ANSI C63.4-2003 and the guidelines in ANSI C63.10-2009 test site requirement.
2. Applies to band edge emissions that fall in the restricted bands listed in FCC Section 15.205. The maximum permitted average field strength is listed in FCC Section 15.209. A pre-amp is necessary for this measurement. For measurements above 1 GHz, set RBW = 1MHz, VBW = 1MHz, Sweep: Auto for Peak; set RBW = 1MHz, VBW = 10 Hz, Sweep: Auto for Average. If the emission is pulsed, modify the unit for continuous operation; use the settings shown above, then correct the reading by subtracting the peak-average correction factor, derived from the appropriate duty cycle calculation. See FCC Section 15.35(b) and (c).
3. In case the emission is fail due to the used RBW / VBW is too wide, marker-delta method of FCC Public Notice DA 00-705 will be followed.

3.8.4 Test Setup

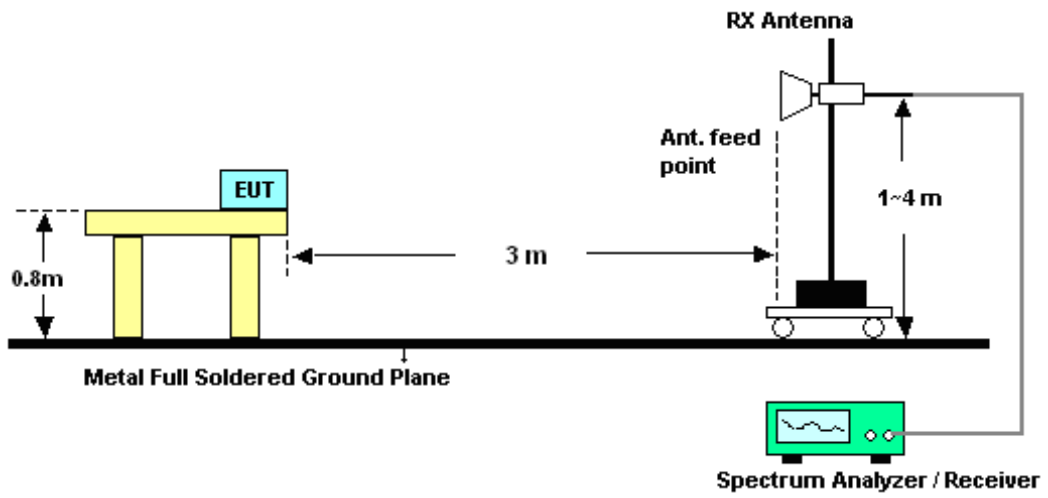



3.8.5 Test Result of Radiated Band Edges

Test Mode :	1Mbps	Temperature :	21~22 °C
Test Channel :	00	Relative Humidity :	42~43%
		Test Engineer :	Jack Li

ANTENNA POLARITY : HORIZONTAL										
Frequency (MHz)	Level (dBμV/m)	Over Limit (dB)	Limit Line (dBμV/m)	Read Level (dBμV)	Antenna Factor (dB)	Cable Loss (dB)	Preamp Factor (dB)	Ant Pos (cm)	Table Pos (deg)	Remark
2310	46.35	-27.65	74	44.26	32.73	3.22	33.86	197	213	Peak
2310	34.27	-19.73	54	32.18	32.73	3.22	33.86	197	213	Average

ANTENNA POLARITY : VERTICAL										
Frequency (MHz)	Level (dBμV/m)	Over Limit (dB)	Limit Line (dBμV/m)	Read Level (dBμV)	Antenna Factor (dB)	Cable Loss (dB)	Preamp Factor (dB)	Ant Pos (cm)	Table Pos (deg)	Remark
2359.97	46.1	-27.9	74	43.89	32.81	3.38	33.98	122	216	Peak
2359.97	33.45	-20.55	54	31.24	32.81	3.38	33.98	122	216	Average



Test Mode :	1Mbps	Temperature :	21~22 °C
Test Channel :	78	Relative Humidity :	42~43%
		Test Engineer :	Jack Li

ANTENNA POLARITY : HORIZONTAL										
Frequency (MHz)	Level (dBuV/m)	Over Limit (dB)	Limit Line (dBuV/m)	Read Level (dBuV)	Antenna Factor (dB)	Cable Loss (dB)	Preamp Factor (dB)	Ant Pos (cm)	Table Pos (deg)	Remark
2483.5	40.76	-33.24	74	38.27	33.01	3.68	34.2	112	206	Peak
2483.5	27.47	-26.53	54	24.98	33.01	3.68	34.2	112	206	Average

Summary results of marker-delta method:

Test mode	Maximum field strength of the fundamental emission (dBμV/m)	Delta Result (dB)	Average Result (dBμV/m)	Average Limit (dBμV/m)	Margin (dB)	Result
Single Carrier Mode	79.89	52.42	27.47	54	-26.53	Pass
Hopping Mode	79.89	52.76	27.13	54	-26.87	Pass

Note: Average result = Maximum field strength – Delta result

ANTENNA POLARITY : VERTICAL										
Frequency (MHz)	Level (dBuV/m)	Over Limit (dB)	Limit Line (dBuV/m)	Read Level (dBuV)	Antenna Factor (dB)	Cable Loss (dB)	Preamp Factor (dB)	Ant Pos (cm)	Table Pos (deg)	Remark
2484.16	40.94	-33.06	74	38.45	33.01	3.68	34.2	152	114	Peak
2484.16	29.35	-24.65	54	26.86	33.01	3.68	34.2	152	114	Average

Summary results of marker-delta method:

Test mode	Maximum field strength of the fundamental emission (dBμV/m)	Delta Result (dB)	Average Result (dBμV/m)	Average Limit (dBμV/m)	Margin (dB)	Result
Single Carrier Mode	75.65	46.3	29.35	54	-24.65	Pass
Hopping Mode	75.65	47.47	28.18	54	-25.82	Pass

Note: Average result = Maximum field strength – Delta result



Test Mode :	1Mbps	Temperature :	21~22 °C
Test Channel :	78	Relative Humidity :	42~43%
Test Engineer :	Jack Li	Polarization :	Horizontal

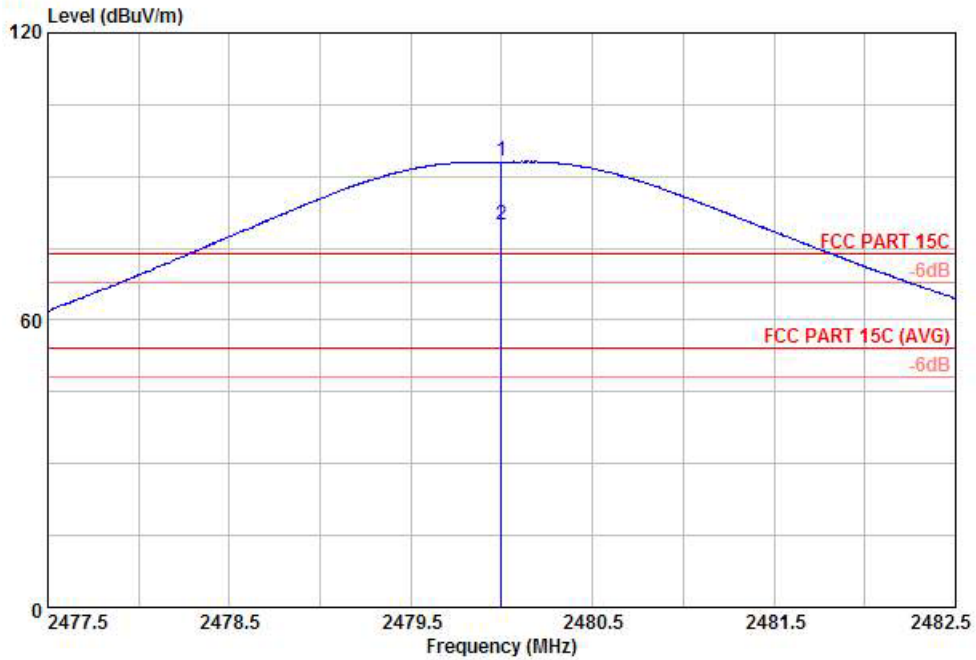

Site : 03CH01-KS
 Condition: FCC PART 15C 3m HF ANT-100803 HORIZONTAL
 Project : (FR) 260404
 Mode : mode 3
 Plane : H
 : DH5

	Freq	Level	Over	Limit	ReadAntenna	Cable	Preamp	Ant	Table	
	MHz	dBuV/m	Limit	Line	Level	Loss	Factor	Pos	Pos	Remark
			dB	dBuV/m	dBuV	dB	dB	cm	deg	
1 X	2480.00	93.15	19.15	74.00	90.66	33.01	3.68	34.20	176	360 Peak
2 X	2480.00	79.89	25.89	54.00	77.40	33.01	3.68	34.20	176	360 Average

* Maximum field strength of the fundamental emission



Test Mode :	1Mbps	Temperature :	21~22 °C
Test Channel :	78	Relative Humidity :	42~43%
Test Engineer :	Jack Li	Polarization :	Horizontal

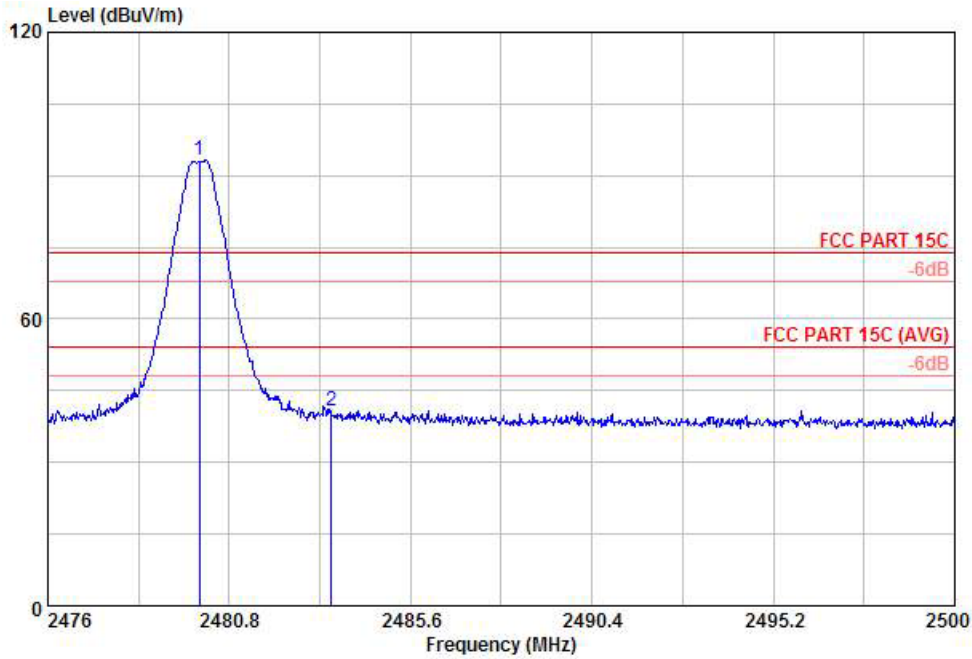

Site : 03CH01-KS
 Condition: FCC PART 15C 3m HF ANTI-100803 HORIZONTAL
 Project : (FR) 260404
 Mode : mode 3
 Plane : H
 : DH5

	Freq	Level	Over	Limit	ReadAntenna	Cable	Preamp	Ant	Table	
	MHz	dBuV/m	dB	dBuV/m	dBuV	dB/m	dB	dB	cm	deg
1 X	2480.00	93.18	19.18	74.00	90.69	33.01	3.68	34.20	175	358 Peak
2	2483.50	40.76	-33.24	74.00	38.27	33.01	3.68	34.20	112	206 Peak

* Marker-Delta Method (RBW/VBW=100KHz): 52.42 dB , single carrier Mode



Test Mode :	1Mbps	Temperature :	21~22 °C
Test Channel :	78	Relative Humidity :	42~43%
Test Engineer :	Jack Li	Polarization :	Horizontal

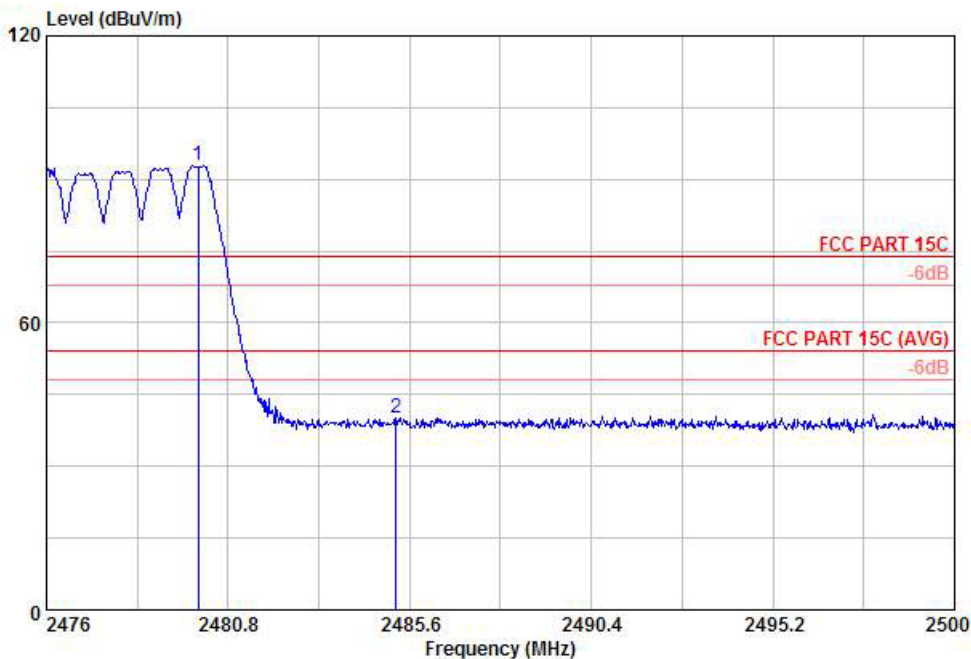

Site : 03CH01-KS
 Condition: FCC PART 15C 3m HF ANT-100803 HORIZONTAL
 Project : (FR) 260404
 Mode : mode 3
 Plane : H
 : DHS

	Freq	Level	Over Limit	Limit Line	ReadAntenna Level	Antenna Factor	Cable Loss	Preamp Factor	Ant Pos	Table Pos	Remark
	MHz	dBuV/m	dB	dBuV/m	dBuV	dB/m	dB	dB	cm	deg	
1 X	2480.00	92.86	18.86	74.00	90.37	33.01	3.68	34.20	176	358	Peak
2	2485.24	40.10	-33.90	74.00	37.61	33.01	3.68	34.20	136	164	Peak

* Marker-Delta Method (RBW/VBW=100KHz): 52.76 dB , Hopping Mode



Test Mode :	1Mbps	Temperature :	21~22 °C
Test Channel :	78	Relative Humidity :	42~43%
Test Engineer :	Jack Li	Polarization :	Vertical

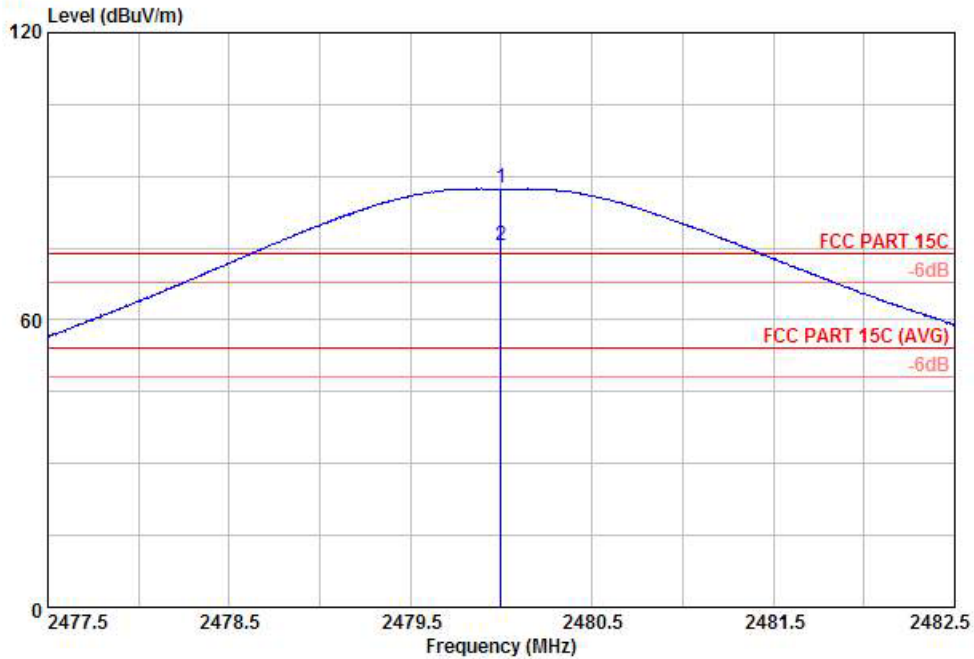

Site : 03CH01-KS
 Condition: FCC PART 15C 3m HF ANT-100803 VERTICAL
 Project : (FR) 260404
 Mode : mode 3
 Plane : H
 : DH5

	Freq	Level	Over	Limit	ReadAntenna	Cable	Preamp	Ant	Table	Remark
	MHz	dBuV/m	dB	dBuV/m	dBuV	dB/m	dB	dB	cm	deg
1 X	2480.00	87.42	13.42	74.00	84.93	33.01	3.68	34.20	106	1 Peak
2 X	2480.00	75.65	21.65	54.00	73.16	33.01	3.68	34.20	106	1 Average

* Maximum field strength of the fundamental emission



Test Mode :	1Mbps	Temperature :	21~22 °C
Test Channel :	78	Relative Humidity :	42~43%
Test Engineer :	Jack Li	Polarization :	Vertical

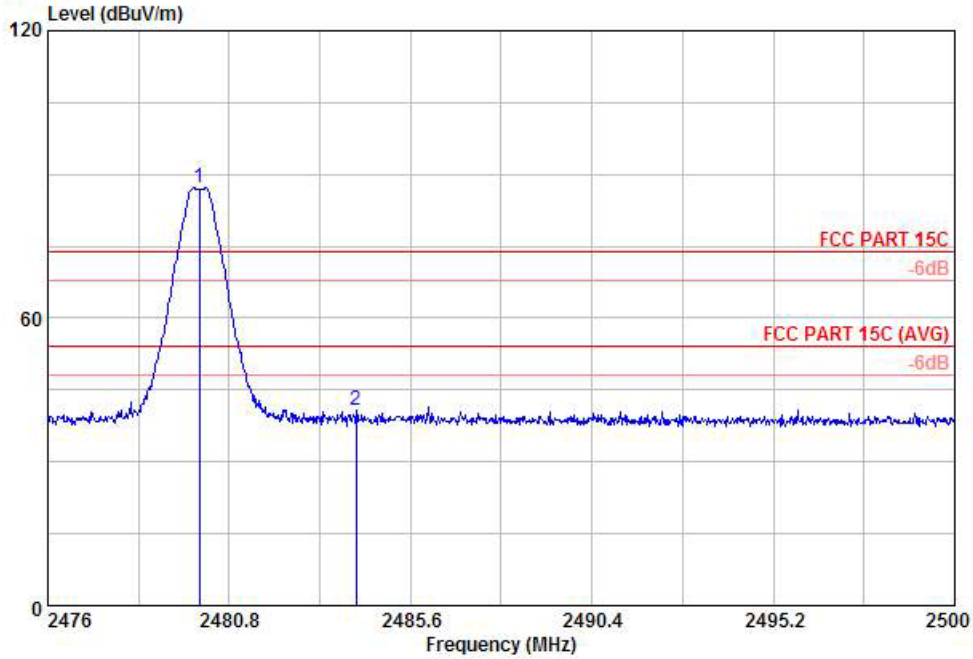

Site : 03CH01-KS
 Condition: FCC PART 15C 3m HF ANI-100803 VERTICAL
 Project : (FR) 260404
 Mode : mode 3
 Plane : H
 : DH5

	Freq	Level	Over Limit	Limit Line	ReadAntenna Level	Antenna Factor	Cable Loss	Preamp Factor	Ant Pos	Table Pos	Remark
	MHz	dBuV/m	dB	dBuV/m	dBuV	dB/m	dB	dB	cm	deg	
1 X	2480.00	87.24	13.24	74.00	84.75	33.01	3.68	34.20	103	360	Peak
2	2484.16	40.94	-33.06	74.00	38.45	33.01	3.68	34.20	152	114	Peak

* Marker-Delta Method (RBW/VBW=100KHz): 46.3 dB , single carrier Mode



Test Mode :	1Mbps	Temperature :	21~22 °C
Test Channel :	78	Relative Humidity :	42~43%
Test Engineer :	Jack Li	Polarization :	Vertical

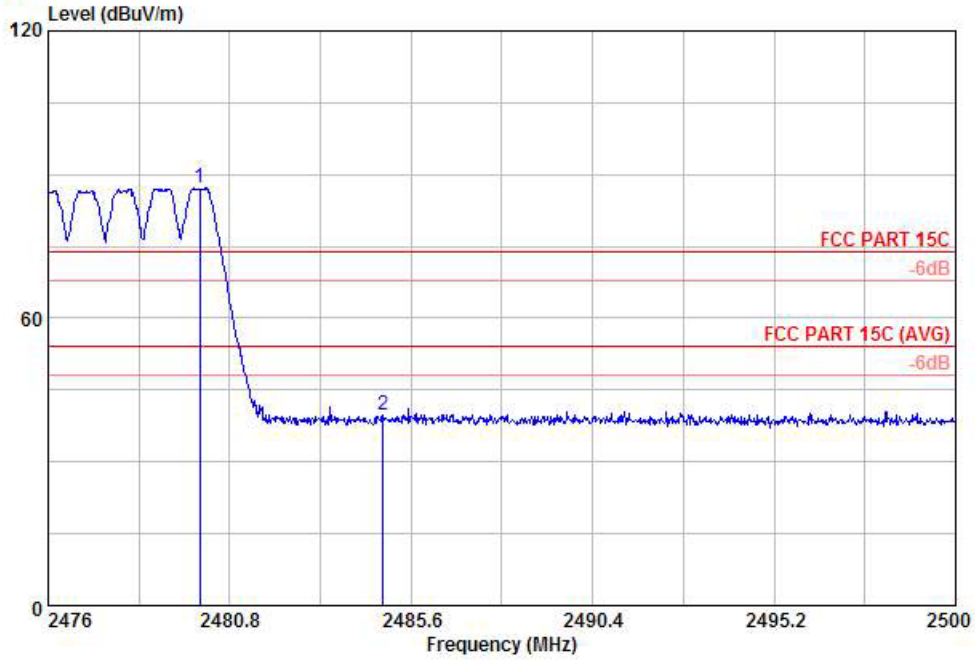

Site : 03CH01-KS
 Condition: FCC PART 15C 3m HF ANI-100803 VERTICAL
 Project : (FR) 260404
 Mode : mode 3
 Plane : H
 : DH5

	Freq	Level	Over	Limit	ReadAntenna	Cable	Preamp	Ant	Table	
	MHz	dBuV/m	dB	dBuV/m	dBuV	Loss	Factor	Pos	Pos	Remark
						dB	dB	cm	deg	
1 X	2480.00	87.17	13.17	74.00	84.68	33.01	3.68	34.20	106	360 Peak
2	2484.86	39.70	-34.30	74.00	37.21	33.01	3.68	34.20	120	223 Peak

* Marker-Delta Method (RBW/VBW=100KHz): 47.47 dB , Hopping Mode

3.9 Radiated Spurious Emission Measurement

3.9.1 Limit of Radiated Emission

In any 100 KHz bandwidth outside the intentional radiator frequency band, all harmonics/spurious must be at least 20 dB below the highest emission level within the authorized band. In addition, radiated emissions which fall in the restricted bands must also comply with the FCC section 15.209 limits as below.

Frequency (MHz)	Field Strength (microvolts/meter)	Measurement Distance (meters)
0.009 – 0.490	2400/F(KHz)	300
0.490 – 1.705	24000/F(KHz)	30
1.705 – 30.0	30	30
30 – 88	100	3
88 – 216	150	3
216 - 960	200	3
Above 960	500	3

3.9.2 Measuring Instruments

See list of measuring instruments of this test report.



3.9.3 Test Procedures

1. The testing follows the guidelines in Spurious Radiated Emissions of FCC Public Notice DA 00-705 Measurement Guidelines and fulfills ANSI C63.4-2003 and the guidelines in ANSI C63.10-2009 test site requirement.
2. Applies to band edge emissions that fall in the restricted bands listed in FCC Section 15.205. The maximum permitted average field strength is listed in FCC Section 15.209. A pre-amp is necessary for this measurement. For measurements above 1 GHz, set RBW = 1MHz, VBW = 1MHz, Sweep: Auto for Peak; set RBW = 1MHz, VBW = 10 Hz, Sweep: Auto for Average. If the emission is pulsed, modify the unit for continuous operation; use the settings shown above, then correct the reading by subtracting the peak-average correction factor, derived from the appropriate duty cycle calculation. See FCC Section 15.35(b) and (c).
3. Follow the guidelines in ANSI C63.4-2003 and ANSI C63.10-2009 with respect to maximizing the emission by rotating the EUT, measuring the emission for three EUT orthogonal planes, and adjusting the measurement antenna height and polarization. A pre-amp and a high pass filter are used for this test in order to get the good signal level.
4. Measured average value if the peak value is greater than 54 dBu/m

3.9.4 Test Setup

For radiated emissions below 30MHz

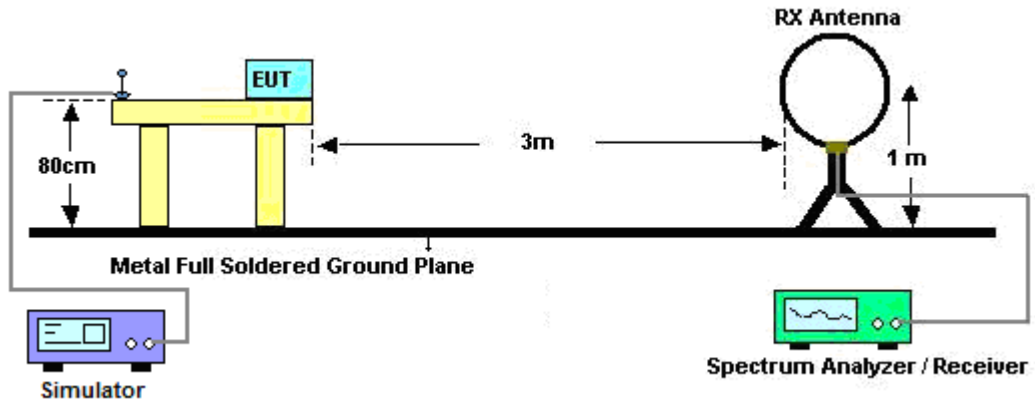

For radiated emissions from 30MHz to 1GHz

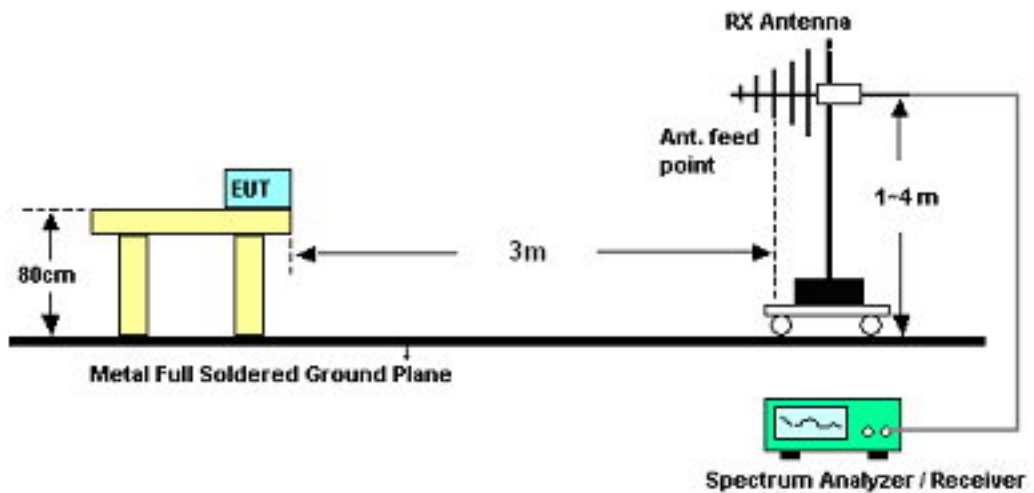

For radiated emissions above 1GHz

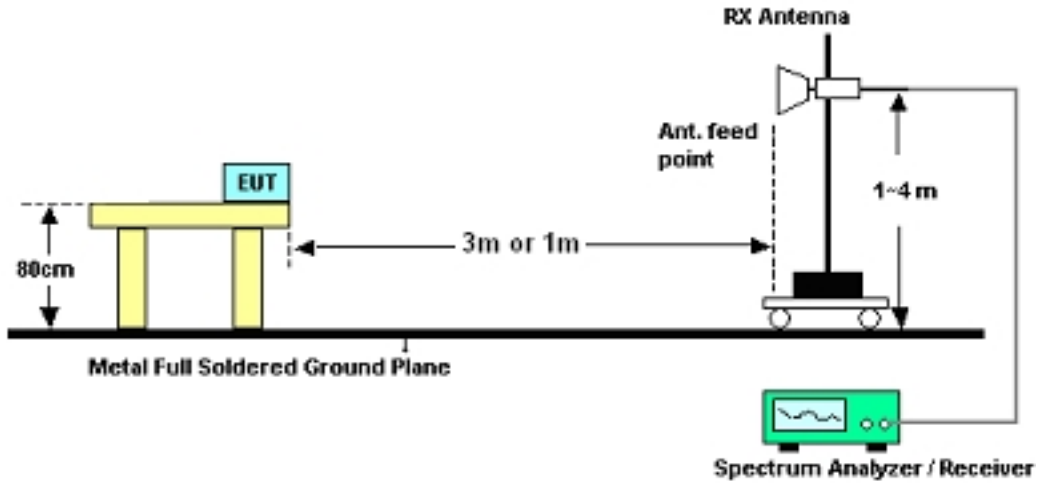

3.9.5 Test Results of Radiated Emissions (9 KHz ~ 30 MHz)

The low frequency, which started from 9 KHz to 30MHz, was pre-scanned and the result which was 20dB lower than the limit line per 15.31(o) was not reported.

3.9.6 Test Result of Radiated Emission (30 MHz ~ 10th Harmonic)

Test Mode :	1Mbps	Temperature :	21~22 °C
Test Channel :	00	Relative Humidity :	42~43%
Test Engineer :	Jack Li	Polarization :	Horizontal
Remark :	2402 MHz is fundamental signal which can be ignored.		

Frequency (MHz)	Level (dBμV/m)	Over Limit (dB)	Limit Line (dBμV/m)	Read Level (dBμV)	Antenna Factor (dB)	Cable Loss (dB)	Preamp Factor (dB)	Ant Pos (cm)	Table Pos (deg)	Remark
103.72	36.67	-6.83	43.5	55.2	11.01	0.42	29.96	103	347	Peak
527.61	26.11	-19.89	46	36.87	17.96	0.98	29.7	-	-	Peak
808.91	27.81	-18.19	46	36.22	19.94	1.25	29.6	-	-	Peak
843.83	27.31	-18.69	46	35.23	20.45	1.28	29.65	-	-	Peak
878.75	26.57	-19.43	46	34.36	20.47	1.29	29.55	-	-	Peak
944.71	34.2	-11.8	46	41.7	20.71	1.33	29.54	-	-	Peak
2310	46.35	-27.65	74	44.26	32.73	3.22	33.86	197	213	Peak
2310	34.27	-19.73	54	32.18	32.73	3.22	33.86	197	213	Average
2402	88.1	-	-	85.82	32.86	3.47	34.05	100	355	Peak
2402	75.55	-	-	73.27	32.86	3.47	34.05	100	355	Average
2489.93	46.09	-27.91	74	43.55	33.05	3.72	34.23	144	106	Peak
2489.93	33.91	-20.09	54	31.37	33.05	3.72	34.23	144	106	Average



Test Mode :	1Mbps	Temperature :	21~22 °C
Test Channel :	00	Relative Humidity :	42~43%
Test Engineer :	Jack Li	Polarization :	Vertical
Remark :	2402 MHz is fundamental signal which can be ignored.		

Frequency (MHz)	Level (dBμV/m)	Over Limit (dB)	Limit Line (dBμV/m)	Read Level (dBμV)	Antenna Factor (dB)	Cable Loss (dB)	Preamp Factor (dB)	Ant Pos (cm)	Table Pos (deg)	Remark
30	26.94	-13.06	40	38.76	18	0.26	30.08	-	-	Peak
102.75	33.91	-9.59	43.5	52.58	10.87	0.42	29.96	200	12	Peak
729.37	27.57	-18.43	46	36.34	19.68	1.16	29.61	-	-	Peak
843.83	25.46	-20.54	46	33.38	20.45	1.28	29.65	-	-	Peak
879.72	27.1	-18.9	46	34.89	20.47	1.29	29.55	-	-	Peak
944.71	33.82	-12.18	46	41.32	20.71	1.33	29.54	-	-	Peak
2359.97	46.1	-27.9	74	43.89	32.81	3.38	33.98	122	216	Peak
2359.97	33.45	-20.55	54	31.24	32.81	3.38	33.98	122	216	Average
2402	81.77	-	-	79.49	32.86	3.47	34.05	101	310	Peak
2402	71.12	-	-	68.84	32.86	3.47	34.05	101	310	Average
2489.36	46.36	-27.64	74	43.82	33.05	3.72	34.23	200	77	Peak
2489.36	33.88	-20.12	54	31.34	33.05	3.72	34.23	200	77	Average



Test Mode :	1Mbps	Temperature :	21~22 °C
Test Channel :	39	Relative Humidity :	42~43%
Test Engineer :	Jack Li	Polarization :	Horizontal
Remark :	2441 MHz is fundamental signal which can be ignored.		

Frequency (MHz)	Level (dBμV/m)	Over Limit (dB)	Limit Line (dBμV/m)	Read Level (dBμV)	Antenna Factor (dB)	Cable Loss (dB)	Preamp Factor (dB)	Ant Pos (cm)	Table Pos (deg)	Remark
102.75	36.42	-7.08	43.5	55.09	10.87	0.42	29.96	101	360	Peak
194.9	22.89	-20.61	43.5	43.54	8.75	0.58	29.98	-	-	Peak
789.51	26.85	-19.15	46	35.33	19.86	1.24	29.58	-	-	Peak
807.94	26.89	-19.11	46	35.31	19.93	1.25	29.6	-	-	Peak
891.36	30.85	-15.15	46	38.59	20.46	1.3	29.5	-	-	Peak
944.71	34.56	-11.44	46	42.06	20.71	1.33	29.54	-	-	Peak
2310	46.44	-27.56	74	44.35	32.73	3.22	33.86	113	149	Peak
2310	34.38	-19.62	54	32.29	32.73	3.22	33.86	113	149	Average
2441	90.02	-	-	87.62	32.95	3.6	34.15	122	2	Peak
2441	77.43	-	-	75.03	32.95	3.6	34.15	122	2	Average
2496.01	45.94	-28.06	74	43.4	33.05	3.72	34.23	100	316	Peak
2496.01	34.17	-19.83	54	31.63	33.05	3.72	34.23	100	316	Average



Test Mode :	1Mbps	Temperature :	21~22 °C
Test Channel :	39	Relative Humidity :	42~43%
Test Engineer :	Jack Li	Polarization :	Vertical
Remark :	2441 MHz is fundamental signal which can be ignored.		

Frequency (MHz)	Level (dBμV/m)	Over Limit (dB)	Limit Line (dBμV/m)	Read Level (dBμV)	Antenna Factor (dB)	Cable Loss (dB)	Preamp Factor (dB)	Ant Pos (cm)	Table Pos (deg)	Remark
36.79	26.6	-13.4	40	42.24	14.19	0.24	30.07	-	-	Peak
102.75	35.34	-8.16	43.5	54.01	10.87	0.42	29.96	200	0	Peak
583.87	24.09	-21.91	46	34.11	18.57	1.05	29.64	-	-	Peak
838.01	25.83	-20.17	46	33.83	20.38	1.27	29.65	-	-	Peak
876.81	25.62	-20.38	46	33.41	20.48	1.29	29.56	-	-	Peak
944.71	34.35	-11.65	46	41.85	20.71	1.33	29.54	-	-	Peak
2321.4	46.42	-27.58	74	44.29	32.76	3.27	33.9	158	245	Peak
2321.4	34.37	-19.63	54	32.24	32.76	3.27	33.9	158	245	Average
2441	82.44	-	-	80.04	32.95	3.6	34.15	107	360	Peak
2441	72.13	-	-	69.73	32.95	3.6	34.15	107	360	Average
2497.15	46.02	-27.98	74	43.48	33.05	3.72	34.23	100	277	Peak
2497.15	34.11	-19.89	54	31.57	33.05	3.72	34.23	100	277	Average



Test Mode :	1Mbps	Temperature :	21~22 °C
Test Channel :	78	Relative Humidity :	42~43%
Test Engineer :	Jack Li	Polarization :	Horizontal
Remark :	2480 MHz is fundamental signal which can be ignored.		

Frequency (MHz)	Level (dBμV/m)	Over Limit (dB)	Limit Line (dBμV/m)	Read Level (dBμV)	Antenna Factor (dB)	Cable Loss (dB)	Preamp Factor (dB)	Ant Pos (cm)	Table Pos (deg)	Remark
94.99	31.61	-11.89	43.5	51.38	9.8	0.4	29.97	-	-	Peak
104.69	34.15	-9.35	43.5	52.54	11.15	0.42	29.96	100	348	Peak
194.9	24.87	-18.63	43.5	45.52	8.75	0.58	29.98	-	-	Peak
798.24	27.19	-18.81	46	35.68	19.85	1.25	29.59	-	-	Peak
824.43	28.24	-17.76	46	36.44	20.16	1.26	29.62	-	-	Peak
943.74	33.05	-12.95	46	40.54	20.71	1.33	29.53	-	-	Peak
2348	45.53	-28.47	74	43.36	32.78	3.33	33.94	102	24	Peak
2348	33.43	-20.57	54	31.26	32.78	3.33	33.94	102	24	Average
2480	93.15	-	-	90.66	33.01	3.68	34.2	176	360	Peak
2480	79.89	-	-	77.4	33.01	3.68	34.2	176	360	Average
2483.5	40.76	-33.24	74	38.27	33.01	3.68	34.2	112	206	Peak
2483.5	27.47	-26.53	54	24.98	33.01	3.68	34.2	112	206	Average



Test Mode :	1Mbps	Temperature :	21~22 °C
Test Channel :	78	Relative Humidity :	42~43%
Test Engineer :	Jack Li	Polarization :	Vertical
Remark :	2480 MHz is fundamental signal which can be ignored.		

Frequency (MHz)	Level (dBμV/m)	Over Limit (dB)	Limit Line (dBμV/m)	Read Level (dBμV)	Antenna Factor (dB)	Cable Loss (dB)	Preamp Factor (dB)	Ant Pos (cm)	Table Pos (deg)	Remark
30	26.79	-13.21	40	38.61	18	0.26	30.08	-	-	Peak
103.72	33.15	-10.35	43.5	51.68	11.01	0.42	29.96	197	13	Peak
532.46	26.2	-19.8	46	36.79	18.11	0.99	29.69	-	-	Peak
575.14	26.04	-19.96	46	36.1	18.55	1.04	29.65	-	-	Peak
798.24	25.88	-20.12	46	34.37	19.85	1.25	29.59	-	-	Peak
944.71	31.99	-14.01	46	39.49	20.71	1.33	29.54	-	-	Peak
2310	45.32	-28.68	74	43.23	32.73	3.22	33.86	200	0	Peak
2310	33.11	-20.89	54	31.02	32.73	3.22	33.86	200	0	Average
2480	87.42	-	-	84.93	33.01	3.68	34.2	106	1	Peak
2480	75.65	-	-	73.16	33.01	3.68	34.2	106	1	Average
2484.16	40.94	-33.06	74	38.45	33.01	3.68	34.2	152	114	Peak
2484.16	29.35	-24.65	54	26.86	33.01	3.68	34.2	152	114	Average

3.10AC Conducted Emission Measurement

3.10.1 Limit of AC Conducted Emission

For equipment that is designed to be connected to the public utility (AC) power line, the radio frequency voltage that is conducted back onto the AC power line on any frequency or frequencies within the band 150 KHz to 30 MHz shall not exceed the limits in the following table.

Frequency of emission (MHz)	Conducted limit (dBuV)	
	Quasi-peak	Average
0.15-0.5	66 to 56*	56 to 46*
0.5-5	56	46
5-30	60	50

*Decreases with the logarithm of the frequency.

3.10.2 Measuring Instruments

See list of measuring instruments of this test report.

3.10.3 Test Procedures

1. Please follow the guidelines in ANSI C63.4-2003 and ANSI C63.10-2009 test site requirement.
2. The EUT was placed 0.4 meter from the conducting wall of the shielding room was kept at least 80 centimeters from any other grounded conducting surface.
3. Connect EUT to the power mains through a line impedance stabilization network (LISN).
4. All the support units are connecting to the other LISN.
5. The LISN provides 50 ohm coupling impedance for the measuring instrument.
6. The FCC states that a 50 ohm, 50 microhenry LISN should be used.
7. Both sides of AC line were checked for maximum conducted interference.
8. The frequency range from 150 KHz to 30 MHz was searched.
9. Set the test-receiver system to Peak Detect Function and specified bandwidth with Maximum Hold Mode.

3.10.4 Test Setup

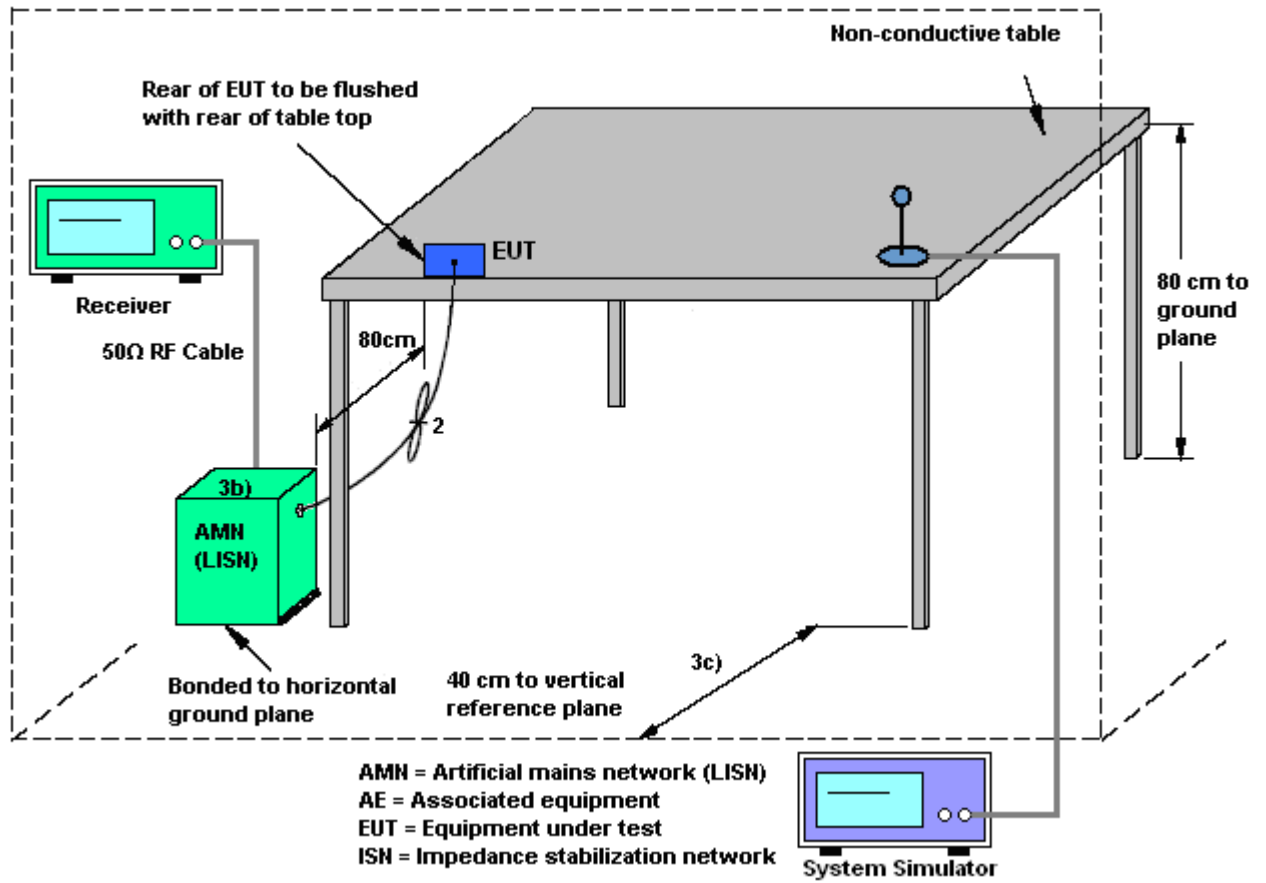



3.10.5 Test Result of AC Conducted Emission

Test Mode :	Mode 1	Temperature :	19~20°C
Test Engineer :	Tom Wang	Relative Humidity :	39~40%
Test Voltage :	120Vac / 60Hz	Phase :	Line
Function Type :	GSM850 Idle + Bluetooth Link + Adapter + Earphone + Camera		
Remark :	All emissions not reported here are more than 10 dB below the prescribed limit.		

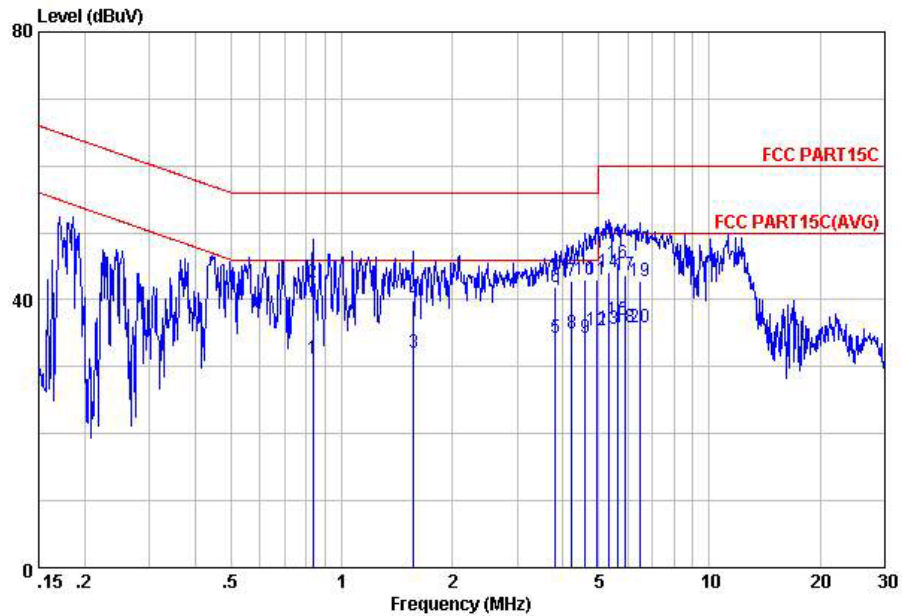

Site : C001-KS
 Condition: FCC PART15C LISN-111230 LINE
 Project : (FR) 260404
 mode : Mode 1

	Freq	Level	Over	Limit	Read	LISN	Cable	Remark
	MHz	dBuV	Limit	Line	Level	Factor	Loss	
			dB	dBuV	dBuV	dB	dB	
1	0.83	31.15	-14.85	46.00	20.59	-0.09	10.65	Average
2	0.83	42.65	-13.35	56.00	32.09	-0.09	10.65	QP
3	1.57	32.18	-13.82	46.00	21.60	-0.11	10.69	Average
4	1.57	39.88	-16.12	56.00	29.30	-0.11	10.69	QP
5	3.82	34.30	-11.70	46.00	23.60	-0.13	10.83	Average
6	3.82	41.90	-14.10	56.00	31.20	-0.13	10.83	QP
7	4.22	42.81	-13.19	56.00	32.11	-0.13	10.83	QP
8	4.22	35.01	-10.99	46.00	24.31	-0.13	10.83	Average
9	4.60	34.31	-11.69	46.00	23.60	-0.13	10.84	Average
10	4.60	43.01	-12.99	56.00	32.30	-0.13	10.84	QP
11	4.93	42.92	-13.08	56.00	32.20	-0.13	10.85	QP
12	4.93	35.52	-10.48	46.00	24.80	-0.13	10.85	Average
13	5.30	35.63	-14.37	50.00	24.90	-0.13	10.86	Average
14	5.30	44.13	-15.87	60.00	33.40	-0.13	10.86	QP
15	5.65	37.04	-12.96	50.00	26.30	-0.13	10.87	Average
16	5.65	45.54	-14.46	60.00	34.80	-0.13	10.87	QP
17	5.90	43.65	-16.35	60.00	32.90	-0.13	10.88	QP
18	5.90	35.95	-14.05	50.00	25.20	-0.13	10.88	Average
19	6.45	42.87	-17.13	60.00	32.10	-0.13	10.90	QP
20	6.45	35.87	-14.13	50.00	25.10	-0.13	10.90	Average



Test Mode :	Mode 1	Temperature :	19~20°C
Test Engineer :	Tom Wang	Relative Humidity :	39~40%
Test Voltage :	120Vac / 60Hz	Phase :	Neutral
Function Type :	GSM850 Idle + Bluetooth Link + Adapter + Earphone + Camera		
Remark :	All emissions not reported here are more than 10 dB below the prescribed limit.		

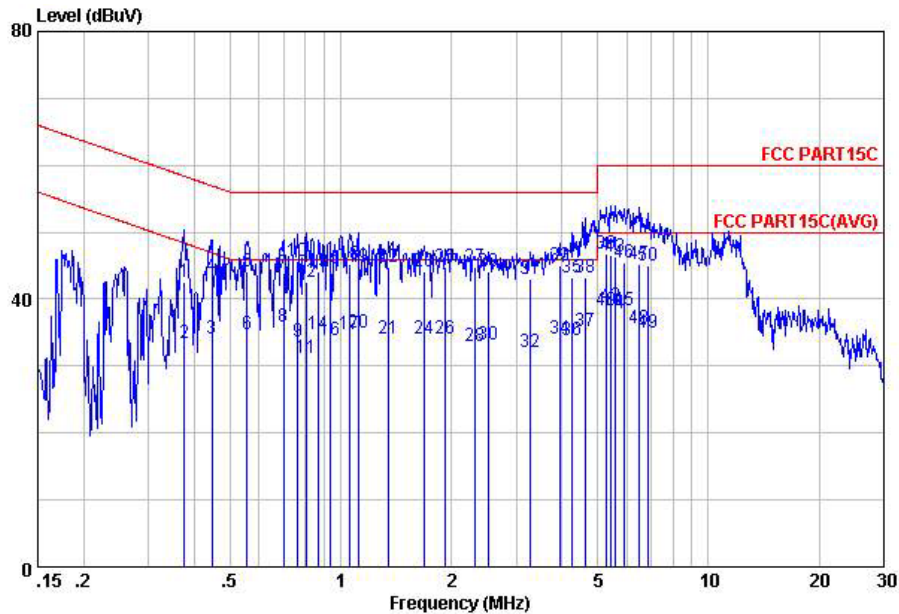

Site : C001-KS
 Condition: FCC PART15C LISN-111230 NEUTRAL
 Project : (FR) 260404
 mode : Mode 1

	Freq	Level	Over	Limit	Read	LISN	Cable	Remark
	MHz	dBuV	Limit	Line	Level	Factor	Loss	
		dBuV	dB	dBuV	dBuV	dB	dB	
1	0.38	42.54	-15.85	58.39	32.01	-0.08	10.61	QP
2	0.38	33.54	-14.85	48.39	23.01	-0.08	10.61	Average
3	0.45	34.04	-12.89	46.93	23.50	-0.08	10.62	Average
4	0.45	43.54	-13.39	56.93	33.00	-0.08	10.62	QP
5	0.56	44.05	-11.95	56.00	33.50	-0.08	10.63	QP
6	0.56	34.85	-11.15	46.00	24.30	-0.08	10.63	Average
7	0.70	43.96	-12.04	56.00	33.40	-0.08	10.64	QP
8	0.70	35.86	-10.14	46.00	25.30	-0.08	10.64	Average
9	0.76	33.66	-12.34	46.00	23.10	-0.08	10.64	Average
10	0.76	45.76	-10.24	56.00	35.20	-0.08	10.64	QP
11	0.80	31.26	-14.74	46.00	20.69	-0.08	10.65	Average
12	0.80	42.56	-13.44	56.00	31.99	-0.08	10.65	QP
13	0.87	44.16	-11.84	56.00	33.60	-0.09	10.65	QP
14	0.87	34.76	-11.24	46.00	24.20	-0.09	10.65	Average
15	0.93	44.66	-11.34	56.00	34.10	-0.09	10.65	QP
16	0.93	33.86	-12.14	46.00	23.30	-0.09	10.65	Average
17	1.06	34.86	-11.14	46.00	24.30	-0.09	10.65	Average
18	1.06	45.16	-10.84	56.00	34.60	-0.09	10.65	QP
19	1.12	44.76	-11.24	56.00	34.20	-0.09	10.65	QP
20	1.12	34.96	-11.04	46.00	24.40	-0.09	10.65	Average
21	1.34	34.07	-11.93	46.00	23.50	-0.10	10.67	Average
22	1.34	44.87	-11.13	56.00	34.30	-0.10	10.67	QP
23	1.68	44.19	-11.81	56.00	33.61	-0.11	10.69	QP
24	1.68	34.19	-11.81	46.00	23.61	-0.11	10.69	Average
25	1.93	44.69	-11.31	56.00	34.10	-0.11	10.70	QP
26	1.93	34.19	-11.81	46.00	23.60	-0.11	10.70	Average
27	2.32	44.71	-11.29	56.00	34.10	-0.11	10.72	QP



	Freq	Level	Over Limit	Limit Line	Read Level	LISN Factor	Cable Loss	Remark
	MHz	dBuV	dB	dBuV	dBuV	dB	dB	
28	2.32	32.91	-13.09	46.00	22.30	-0.11	10.72	Average
29	2.51	44.22	-11.78	56.00	33.60	-0.11	10.73	QP
30	2.51	33.22	-12.78	46.00	22.60	-0.11	10.73	Average
31	3.28	42.98	-13.02	56.00	32.30	-0.12	10.80	QP
32	3.28	31.98	-14.02	46.00	21.30	-0.12	10.80	Average
33	3.94	45.00	-11.00	56.00	34.30	-0.13	10.83	QP
34	3.94	34.00	-12.00	46.00	23.30	-0.13	10.83	Average
35	4.25	43.31	-12.69	56.00	32.61	-0.13	10.83	QP
36	4.25	33.91	-12.09	46.00	23.21	-0.13	10.83	Average
37	4.65	35.21	-10.79	46.00	24.50	-0.13	10.84	Average
38	4.65	43.21	-12.79	56.00	32.50	-0.13	10.84	QP
39	5.28	46.83	-13.17	60.00	36.10	-0.13	10.86	QP
40	5.28	38.43	-11.57	50.00	27.70	-0.13	10.86	Average
41	5.45	46.63	-13.37	60.00	35.90	-0.13	10.86	QP
42	5.45	39.03	-10.97	50.00	28.30	-0.13	10.86	Average
43	5.59	46.44	-13.56	60.00	35.70	-0.13	10.87	QP
44	5.59	37.94	-12.06	50.00	27.20	-0.13	10.87	Average
45	5.93	38.35	-11.65	50.00	27.60	-0.13	10.88	Average
46	5.93	45.55	-14.45	60.00	34.80	-0.13	10.88	QP
47	6.49	45.27	-14.73	60.00	34.50	-0.13	10.90	QP
48	6.49	35.67	-14.33	50.00	24.90	-0.13	10.90	Average
49	6.84	35.09	-14.91	50.00	24.30	-0.13	10.92	Average
50	6.84	44.99	-15.01	60.00	34.20	-0.13	10.92	QP



3.11 Antenna Requirements

3.11.1 Standard Applicable

If directional gain of transmitting antennas is greater than 6dBi, the power shall be reduced by the same level in dB comparing to gain minus 6dBi. The use of a permanently attached antenna or of an antenna that uses a unique coupling to the intentional radiator shall be considered sufficient to comply with the FCC rule.

3.11.2 Antenna Connected Construction

Non-standard connector used.

3.11.3 Antenna Gain

The antenna peak gain of EUT is less than 6 dBi. Therefore, it is not necessary to reduce maximum peak output power limit.



4 List of Measuring Equipment

Instrument	Manufacturer	Model No.	Serial No.	Characteristics	Calibration Date	Test Date	Due Date	Remark
Spectrum Analyzer	R&S	FSP40	100319	9kHz~40GHz	Dec. 30, 2011	Jun. 13, 2012~ Jun.15, 2012	Dec. 29, 2012	Conducted (TH01-KS)
Power Meter	Agilent	E4416A	MY45101555	N/A	Aug. 23, 2011	Jun. 13, 2012~ Jun.15, 2012	Aug. 22, 2012	Conducted (TH01-KS)
Power Sensor	Agilent	E9327A	MY44421198	N/A	Aug. 23, 2011	Jun. 13, 2012~ Jun.15, 2012	Aug. 22, 2012	Conducted (TH01-KS)
DC Power Supply	GWINSTEK	GPS-3030D	E1884515	N/A	Aug. 23, 2011	Jun. 13, 2012~ Jun.15, 2012	Aug. 22, 2012	Conducted (TH01-KS)
Thermal Chamber	Ten Billion	TTC-B3S	TBN-960502	N/A	Dec. 30, 2011	Jun. 13, 2012~ Jun.15, 2012	Dec. 29, 2012	Conducted (TH01-KS)
Bluetooth Base Station	R&S	CBT	100783	N/A	Aug. 18, 2011	Jun. 13, 2012~ Jun.15, 2012	Aug. 17, 2012	Conducted (TH01-KS)
EMI Test Receiver	R&S	ESCI	100534	9kHz~3GHz	Nov. 09, 2011	Jun. 30, 2012	Nov. 08, 2012	Radiation (03CH01-KS)
Spectrum Analyzer	R&S	FSP40	100319	9kHz~40GHz	Dec. 30, 2011	Jun. 30, 2012	Dec. 29, 2012	Radiation (03CH01-KS)
Bilog Antenna	SCHAFFNER	CBL6112D	23182	25MHz~2GHz	Dec. 08, 2011	Jun. 30, 2012	Dec. 07, 2012	Radiation (03CH01-KS)
Loop Antenna	R&S	HFH2-Z2	860004/00	9 kHz~30 MHz	Jul. 28, 2011	Jun. 30, 2012	Jul. 27, 2012	Radiation (03CH01-KS)
Double Ridge Horn Antenna	EMCO	3117	00075959	1GHz~18GHz	Jan. 06, 2012	Jun. 30, 2012	Jan. 05, 2013	Radiation (03CH01-KS)
Amplifier	Wireless	FPA-6592G	060004	30MHz~2GHz	Dec. 30, 2011	Jun. 30, 2012	Dec. 29, 2012	Radiation (03CH01-KS)
Amplifier	Agilent	8449B	3008A02370	1GHz~26.5GHz	Dec. 30, 2011	Jun. 30, 2012	Dec. 29, 2012	Radiation (03CH01-KS)
Active Horn Antenna	com-power	AHA-118	701023	1GHz~18GHz	Nov. 07, 2011	Jun. 30, 2012	Nov. 06, 2012	Radiation (03CH01-KS)
SHF-EHF Horn	Schwarzbeck	BBHA 9170	BBHA170249	15GHz~40GHz	Oct. 11, 2011	Jun. 30, 2012	Oct.10, 2012	Radiation (03CH01-KS)
Bluetooth Base Station	R&S	CBT	100783	N/A	Aug. 18, 2011	Jun. 15, 2012	Aug. 17, 2012	Radiation (03CH01-KS)
EMI Receiver	R&S	ESCI7	100768	9kHz~7GHz	Jun. 01, 2012	Jun. 15, 2012	May 31, 2013	Conduction (CO01-KS)
LISN	MessTec	AN3016	60103	9kHz~30MHz	Dec. 30, 2011	Jun. 15, 2012	Dec. 29, 2012	Conduction (CO01-KS)
LISN	MessTec	AN3016	60105	9kHz~30MHz	Dec. 30, 2011	Jun. 15, 2012	Dec. 29, 2012	Conduction (CO01-KS)
AC Power Source	Chroma	61602	ABP00000811	N/A	Nov. 16, 2011	Jun. 15, 2012	Nov. 15, 2012	Conduction (CO01-KS)
System Simulator	R&S	CMU200	837587/066	2G Full-Band	Dec. 30, 2011	Jun. 15, 2012	Dec. 29, 2012	Conduction (CO01-KS)



5 Uncertainty of Evaluation

Uncertainty of Conducted Emission Measurement (150 KHz ~ 30 MHz)

Measuring Uncertainty for a Level of Confidence of 95% ($U = 2Uc(y)$)	2.26
---	------

Uncertainty of Radiated Emission Measurement (30 MHz ~ 1000 MHz)

Measuring Uncertainty for a Level of Confidence of 95% ($U = 2Uc(y)$)	2.54
---	------

Uncertainty of Radiated Emission Measurement (1 GHz ~ 40 GHz)

Measuring Uncertainty for a Level of Confidence of 95% ($U = 2Uc(y)$)	4.72
---	------



Appendix A. Photographs of EUT

Please refer to Sporton report number EP260404 as below.