

TEST REPORT

FROM



For

Haier Single Mode CDMA Phone

Model D1000

To

PART 22 CERTIFICATION

Test Report Serial No.: SL050821/RF/01

This report supersedes none

Remarks:

Equipment complied with the specification [X]
Equipment did not comply with the specification []

This Test Report is Issued Under the Authority of:

Tested by: 
Wang Wenjian
Compliance Engineer

Tao Hongbo
Compliance Engineer

Reviewed by: Leslie Bai, Lab Manager

Issue date:August 30, 2005

Equipment Details: Haier Single Mode CDMA Phone Model D1000
Manufacturer: Qingdao Haier Telecom Co., Ltd.



Registration No. 783147



Registration No. 4842



Lab Code: KR0032



RTA No. D23/16V



Registration No. 2195

This test report may be reproduced in full only.

This page has been left blank intentionally.

FCC Part 22 Certification

Applicant Name	Qingdao Haier Telecom Co., Ltd.
FCC ID	SG70508D1000
Test Report Number:	SL050821/RF/01
Test Site:	No. 783147
FRN:	0010188456
EUT Type:	Single-Mode CDMA Phone
Tx Frequency:	824.70 — 848.31 MHz (CDMA)
Rx Frequency:	869.70 — 893.31 MHz (CDMA)
Max. RF Output Power:	0.193 W ERP CDMA (22.9dBm)
Trade Name/Model(s):	Haier / D1000
FCC Classification:	Licensed Portable Transmitter Held to Ear (PCE)
Application Type:	Certification
FCC Rule Part(s):	§22(H), §2
Emission Designator(s):	1M25F9W

This equipment has been shown to be capable of compliance with the applicable technical standards as indicated in the measurement report and was tested in accordance with the measurement procedures specified in § 2.947.

Signatories of this Test Report attest to the accuracy of data. All measurements reported herein were performed by competent SIEMIC Lab technician and are correct to the best of our knowledge and belief. We assume full responsibility for the completeness of these measurements and vouch for the qualifications of all persons taking them.

Table of Contents

ATTACHMENT A: COVER LETTER(S)

ATTACHMENT B: ATTESTATION STATEMENT(S)

ATTACHMENT C: TEST REPORT

1.1 SCOPE	page	5
2.1 INTRODUCTION		6
3.1 INSERTS PER §2.1033(d)		7
4.1 DESCRIPTION OF TESTS		8 - 14
5.1 EFFECTIVE RADIATED POWER OUTPUT		15
6.1 RADIATED MEASUREMENTS		16 - 18
7.1 FREQUENCY STABILITY		19
8.1 PLOTS OF EMISSIONS		20
9.1 LIST OF TEST EQUIPMENT		21
10.1 SAMPLE CALCULATIONS		22
11.1 CONCLUSION		23

ATTACHMENT D: TEST PLOTS

ATTACHMENT E: FCC ID LABEL & LOCATION

ATTACHMENT F: TEST SETUP PHOTOGRAPHS

ATTACHMENT G: EXTERNAL PHOTOGRAPHS

ATTACHMENT H: INTERNAL PHOTOGRAPHS

ATTACHMENT I: BLOCK DIAGRAM (S)

ATTACHMENT J: CIRCUIT DIAGRAMS & DESCRIPTION

ATTACHMENT K: PARTS LIST

ATTACHMENT L: OPERATIONAL DESCRIPTION

ATTACHMENT M: USER'S MANUAL

ATTACHMENT N: SAR MEASUREMENT REPORT

ATTACHMENT O: SAR TEST DATA

ATTACHMENT P: SAR TEST SETUP PHOTOGRAPHS

ATTACHMENT Q: DIPOLE VALIDATION

ATTACHMENT R: PROBE CALIBRATION

ATTACHMENT S: DIPOLE CALIBRATION

ATTACHMENT T: EMI TEST REPORT

MEASUREMENT REPORT

1.1 SCOPE

Measurement and determination of electromagnetic emissions (EME) of radio frequency devices including intentional and/or unintentional radiators for compliance with the technical rules and regulations of the Federal Communications Commission.

General Information

Company Name: Qingdao Haier Telecom Co., Ltd.
Address: No. 1 Haier Road, Hi-Tech Zone
Qingdao 266101 P.R. China

- FCC ID: **SG70508D1000**
- EUT Type: Single-Mode CDMA Phone - Prototype
- Trade Name: Haier
- Model(s): D1000
- Quantity: Quantity production is planned
- Serial Number(s): D1000-001
- Emission Designator(s): 1M25F9W
- Tx Frequency: 824.70 – 848.31 MHz (CDMA)
- Rx Frequency: 869.70 – 893.31 MHz (CDMA)
- Application Type: Certification
- FCC Classification: Licensed Portable Transmitter Held to Ear (PCE)
- FCC Rule Part(s): §22(H), §2
- Modulation(s): CDMA
- Antenna Type: Internal
- Max RF. Output Power: 0.193 W ERP CDMA (22.9dBm)
- Date(s) of Tests: August 15, 2005 – August 19, 2005
- Test Facility: SIEMIC Laboratories
2206 Ringwood Avenue, San Jose
California 95131, USA
- Report No.: SL050821/RF/01

2.1 INTRODUCTION

EUT DESCRIPTION

The Haier D1000 Single-Mode CDMA phone. Its basic purpose is used for communications. It transmits from CDMA (824.70~848.31) MHz and receives from CDMA (869.70~893.31) MHz. The RF power is rated at CDMA (0.193W).

MEASURING INSTRUMENT CALIBRATION

The measuring equipment, which was utilized in performing the tests documented herein, has been calibrated in accordance with the manufacturer's recommendations for utilizing calibration equipment, which is traceable to recognized national standards.

3.1 INSERTS PER §2.1033(d)

Function of Active Devices (Confidential)

The Function of active devices is shown in Attachment K.

Block/Circuit Diagrams & Description (Confidential)

The circuit diagrams & description are shown in Attachment J, and the block diagrams are shown in Attachment I.

Operating Instructions

The instruction manual is shown in Attachment M.

Parts List & Tune-Up Procedure (Confidential)

The parts list & tune-up procedure are shown in Attachment L.

Description of Freq. Stabilization Circuit (Confidential)

The description of frequency stabilization circuit is shown in Attachment K.

Description for Suppression of Spurious Radiation, for Limiting Modulation, and Harmonic Suppression Circuits (Confidential)

The description of suppression stabilization circuits are shown in Attachment K

4 DESCRIPTION OF TESTS

4.1 RF Power output.

Test Set-up

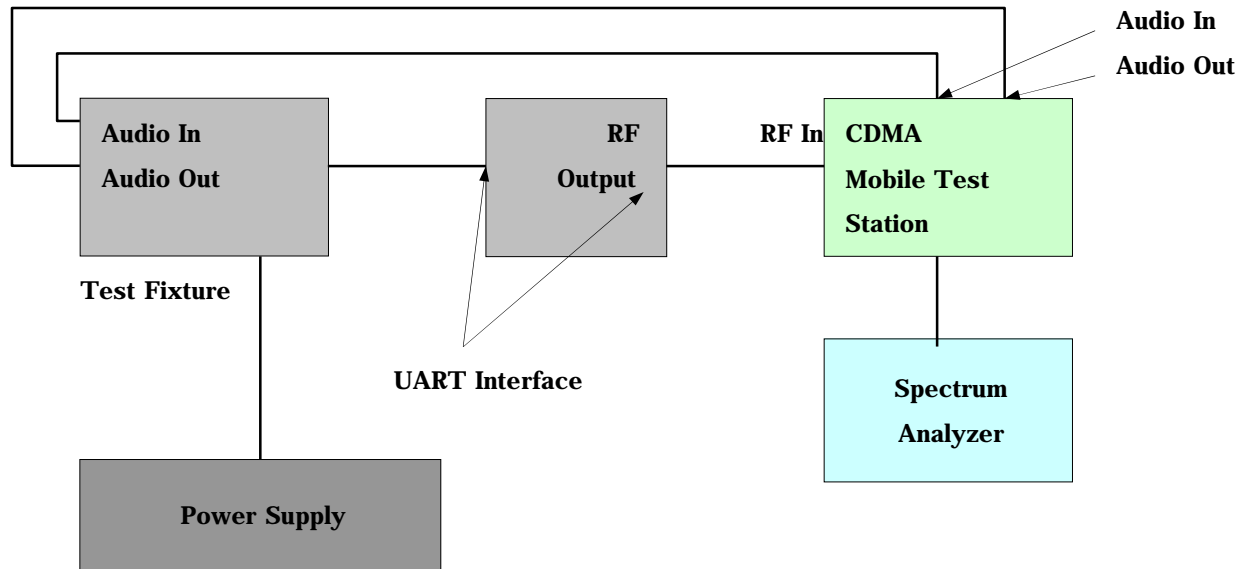

UART Interface: The UART Interface has a serial communication link and RF Interface port that can be used to test , debug or upgrade the phone's functions and characteristics.

EUT : Equipment Under Test

Test Procedure

The power is read at the spectrum analyzer through the duplex port of CDMA mobile test station. RF power output is measured at the RF output terminal (UART Interface) on the bottom side of the EUT.

4.2 Effective Radiated Power

Test Set-up for the ERP/EIRP TEST

Effective Radiated Power Output and Equivalent Isotropic Radiated Power output Measurements by Substitution Method according to ANSI/TIA/EIA-603-A-2001, Aug. 15, 2001:

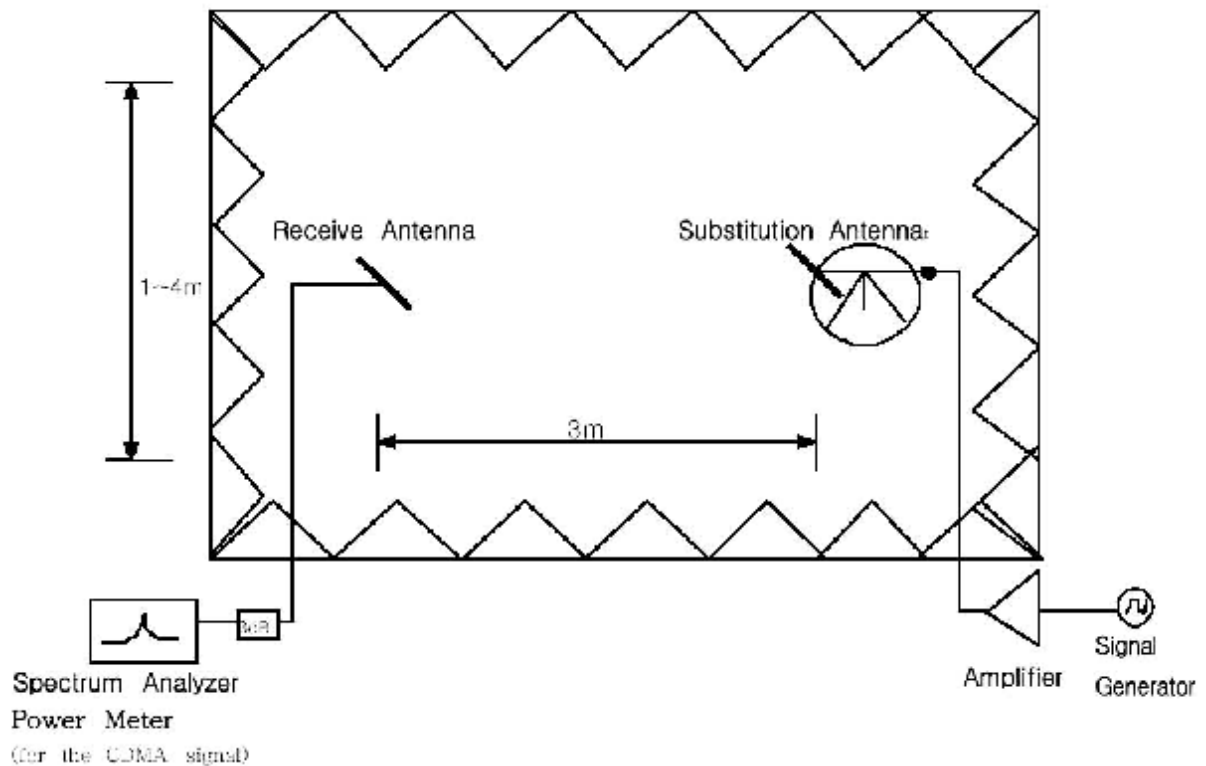

Test Procedure

The EUT was placed on a Non-conducted turntable 3-meters from the receive antenna. The receive antenna height and turntable rotation was adjusted for the highest reading on the receive spectrum analyzer. For CDMA & PCS signals, an average detector is used, with $RBW=VBW=3\text{MHz}$, $SPAN=10\text{MHz}$. A half-wave dipole was substituted in place of the EUT. This dipole antenna was driven by a signal generator and the level of the signal generator was adjusted to obtain the same receive spectrum analyzer reading. The conducted power at the terminals of dipole is measured. The ERP is recorded.

4.3 Occupied bandwidth

Test Set-up

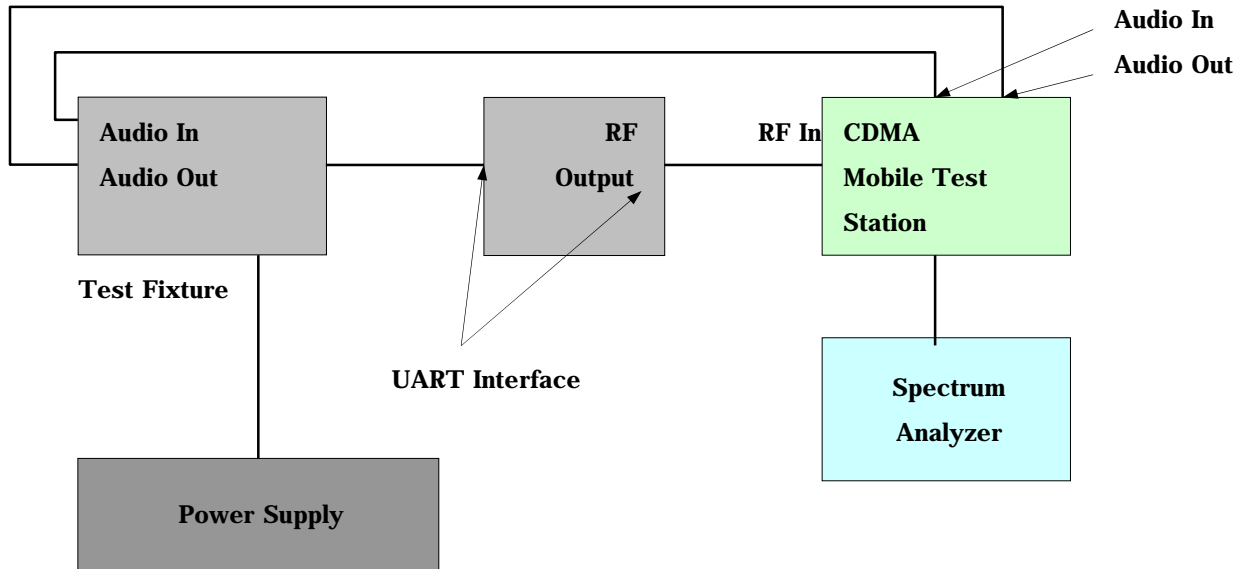

UART Interface: The UART Interface has a serial communication link that can be used to test , debug or upgrade the phone's functions and characteristics.

Test Procedure

The EUT was setup to maximum output power at its lowest channel. The occupied bandwidth was measured using a spectrum analyzer. The measurements are repeated for the highest and a middle channel. The EUT's occupied bandwidth is measured as the width of the signal between two points, one below the carrier center frequency and one above the carrier frequency, outside of which all emissions are attenuated at least 26dB below the transmitter power.

Plots of the EUT's occupied bandwidth are shown herein.

4.4 Spurious and Harmonic Emissions at Antenna Terminal

Test Set-up

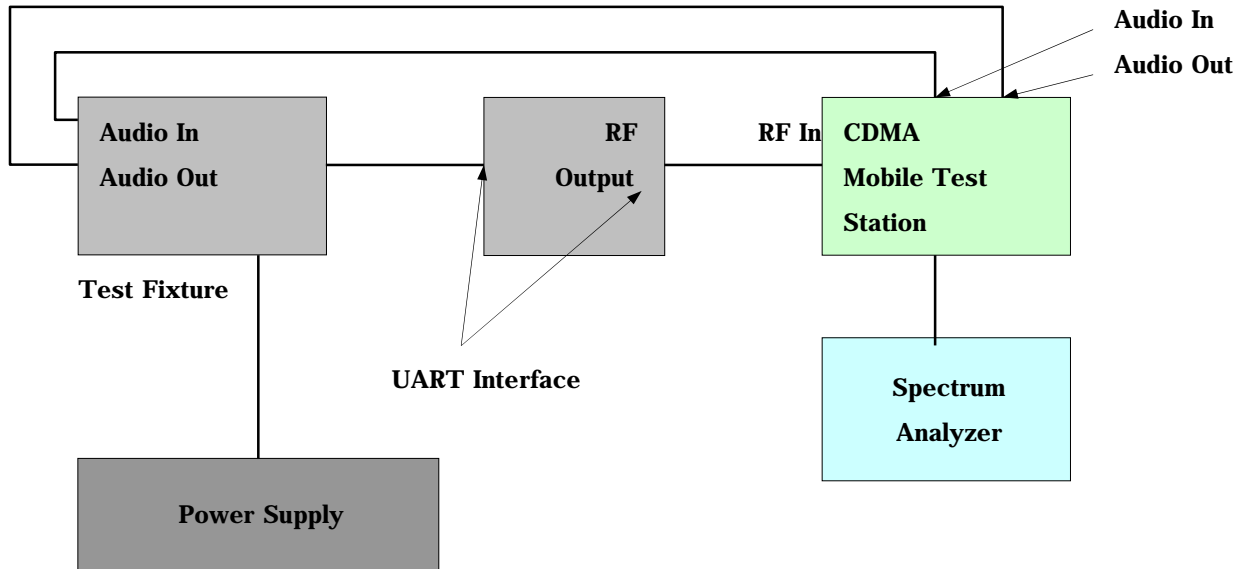

Test Procedure

The level of the carrier and the various conducted spurious and harmonic frequencies is measured by means of a calibrated spectrum analyzer. The spectrum is scanned from the lowest frequency generated in the equipment up to 10 GHz. The transmitter is modulated with a 2500Hz tone at a level of 16dB greater than that required to provide 50% modulation. At the input terminals of the spectrum analyzer, an isolator (RF circulator with one port terminated with 50 ohms) and an 870 MHz to 890 MHz bandpass filter is connected between the test transceiver (for conducted tests) or the receive antenna (for radiated tests) and the analyzer. The rejection of the bandpass filter to signals in the 825 — 845 MHz range is adequate to limit the transmit energy from the test transceiver which appears to a level which will allow the analyzer to measure signals less than —90dBm. Calibration of the test receiver is performed in the 870 — 890 MHz range to insure accuracy to allow variation in the bandpass filter insertion loss to be calibrated.

4.5 Field strength of spurious radiation

Test Set-up for the Radiated Emission TEST

Radiated Spurious Emission Measurements by Substitution Method according to ANSI/TIA/EIA-603-A-2001, Aug. 15, 2001

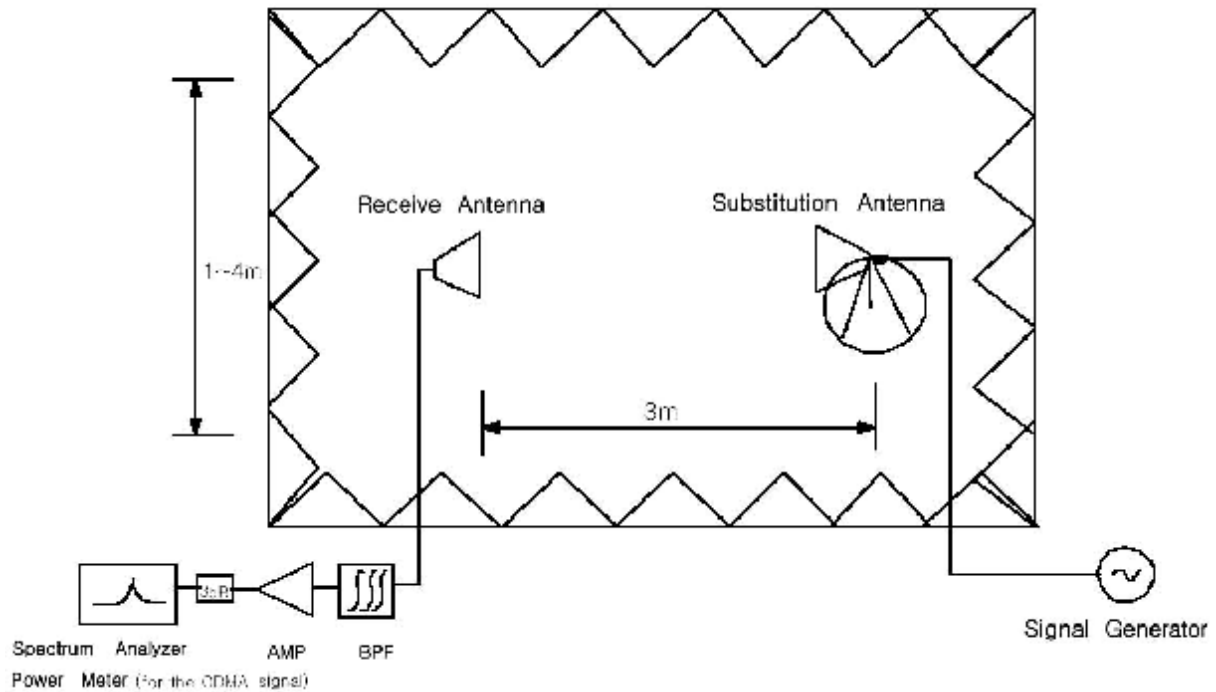

Test Procedure

The EUT was placed on a Non-conducted turntable 3-meters from the receive antenna. The receive antenna height and turntable rotation was adjusted for the highest reading on the receive spectrum analyzer. The Spectrum was investigated from 30MHz to the 10th Harmonic of the fundamental. A peak detector is used, with $RBW=VBW=1\text{MHz}$. The value that we could measure was only reported A half-wave dipole was substituted in place of the EUT. This dipole antenna was driven by a signal generator and the level of the signal generator was adjusted to obtain the same receive spectrum analyzer reading. This spurious level is recorded. For readings above 1GHz, the above procedure is repeated using horn antennas and the difference between the gain of the horn and an isotropic or dipole antenna are taken into consideration.

4.6 Frequency stability

4.6.1 Frequency stability with variation of ambient temperature

Test Set-up

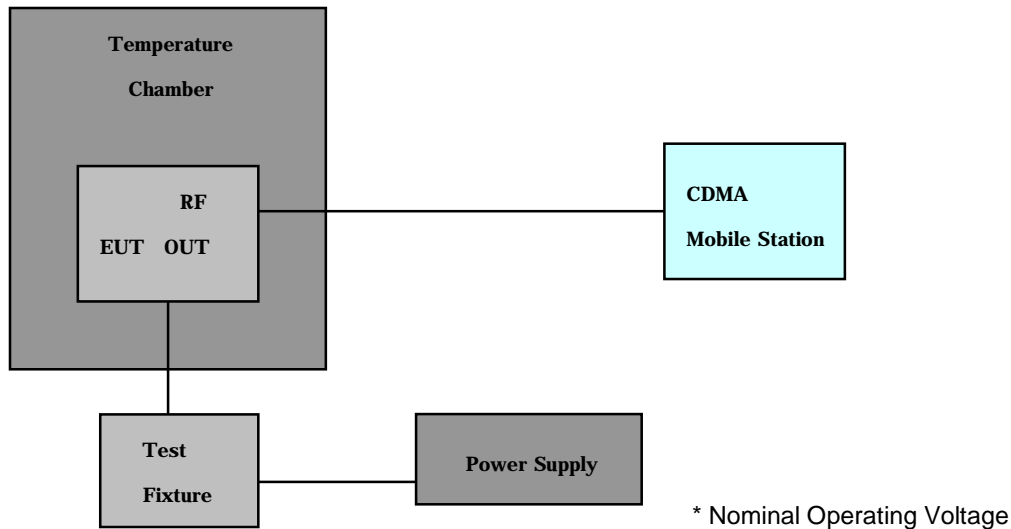

Test Procedure

The frequency stability of the transmitter is measured by:

- a.) **Temperature:** The temperature is varied from -30 °C to +60 °C using an environmental chamber.
- b.) **Primary Supply Voltage:** The primary supply voltage is varied from 85% to 115% of the voltage normally at the input to the device or at the power supply terminals if cables are not normally supplied.

Specification — The frequency stability shall be sufficient to ensure that the fundamental emission stays within the authorized frequency block. The frequency stability of the transmitter shall be maintained within ± 0.0001 (± 1 ppm) of the center frequency.

Time Period and Procedure:

1. The carrier frequency of the transmitter and the individual oscillators is measured at room temperature (25 °C to 27 °C to provide a reference).
2. The equipment is subjected to an overnight "soak" at -30 °C without any power applied.
3. After the overnight "soak" at 30 °C (usually 14-16 hours), the equipment is turned on in a "standby" condition for one minute before applying power to the transmitter. Measurement of the carrier frequency of the transmitter and the individual oscillators is made within a three minute interval after applying power to the transmitter.
4. Frequency measurements are made at 10 °C interval up to room temperature. At least a period of one and one half-hour is provided to allow stabilization of the equipment at each temperature level.
5. Again the transmitter carrier frequency and the individual oscillators are measured at room temperature to begin measurement of the upper temperature levels.
6. Frequency were made at 10 intervals starting at 30 °C up to +50 °C allowing at least two hours at each temperature for stabilization. In all measurements the frequency is measured within three minutes after applying power to the transmitter.
7. The artificial load is mounted external to the temperature chamber.

NOTE: The EUT is tested down to the battery endpoint.

4.6.2 Frequency stability with variation of primary supply voltage

Test Set-up

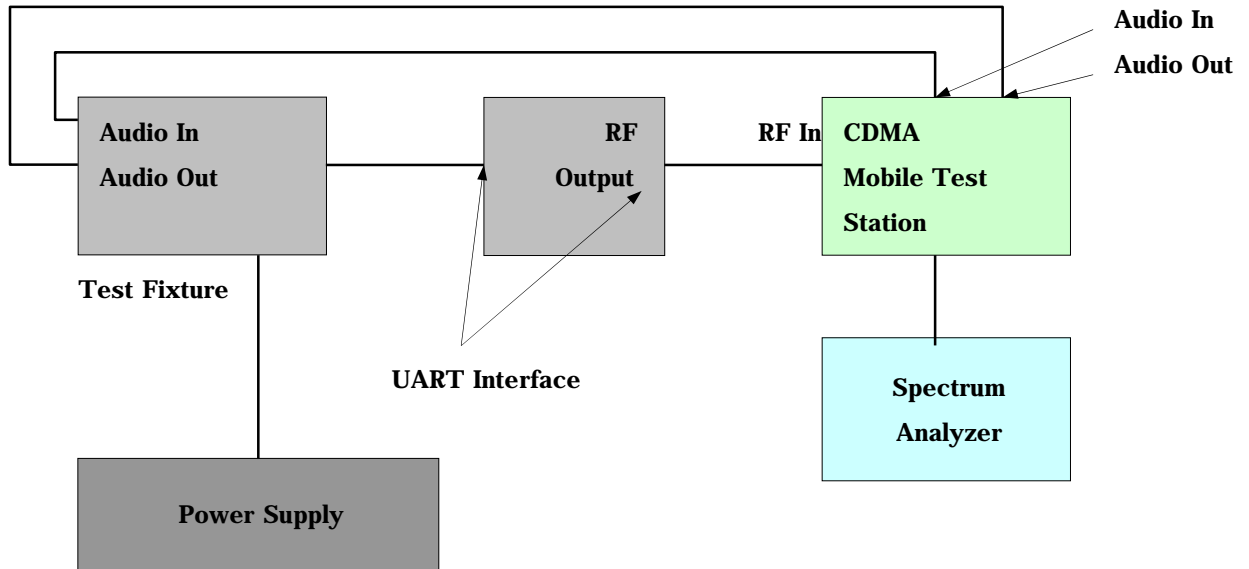

Test Procedure

- 1) The primary supply is varied in steps of 5% from 85 to 115% of the nominal supply voltage, or reduce primary supply voltage to the battery operating end point.
- 2) The frequency is recorded each 5% step.

5.1 Test Data

5.2 Effective Radiated Power Output (CDMA)

Radiated measurements at 3 meters

Modulation: CDMA

Freq. Tuned (MHz)	REF. LEVEL (dBm)	POL (H/V)	ERP (W)	ERP (dBm)	BATTERY
824.70	- 24.3	V	0.191	22.8	Standard
835.89	- 24.3	V	0.193	22.9	Standard
848.31	- 25.1	V	0.160	22.1	Standard

Note: Standard batteries are the only options for this phone

NOTES:

Effective Radiated Power Output Measurements by Substitution Method
according to ANSI/TIA/EIA-603-A-2001, Aug. 15, 2001:

The EUT was placed on a wooden turn table 3-meters from the receive antenna. The receive antenna height and turntable rotation was adjusted for the highest reading on the receive spectrum analyzer. For CDMA signals, a peak detector is used, with RBW=VBW=3MHz. For AMPS, GSM, and NADC TDMA signals, a peak detector is used, with RBW=VBW=1MHz. A Horn antenna was substituted in place of the EUT. This Horn antenna was driven by a signal generator and the level of the signal generator was adjusted to obtain the same receive spectrum analyzer reading. The conducted power at the terminals of the Horn antenna is measured. The difference between the gain of the horn and an isotropic antenna is taken into consideration and the EIRP is recorded.

6.1 Test Data (Continued)

6.2 CELLULAR CDMA Radiated Measurements

Field Strength of SPURIOUS Radiation

■ OPERATING FREQUENCY:	824.70 MHz
■ CHANNEL:	1013 (Low)
■ MEASURED OUTPUT POWER:	22.9 dBm = 0.193 W
■ MODULATION SIGNAL:	CDMA (Internal)
■ DISTANCE:	3 meters
■ LIMIT: $43 + 10 \log_{10} (W) =$	35.86 dBc

Freq. (MHz)	LEVEL @ ANTENNA TERMINALS (dBm)	SUBSTITUTE ANTENNA GAIN (dBd)	CORRECT GENERATOR LEVEL (dBm)	POL (H/V)	(dBc)
1649.40	- 66.8	7.3	- 59.5	V	77.1
2474.10	- 63.7	8.3	- 55.4	V	72.5
3298.80	- 67.5	9.7	- 57.8	V	74.0

NOTES:

Radiated Spurious Emission Measurements by Substitution Method

according to ANSI/TIA/EIA-603-A-2001, Aug. 15, 2001:

The EUT was placed on a wooden turn table 3-meters from the receive antenna. The receive antenna height and turntable rotation was adjusted for the highest reading on the receive spectrum analyzer.

For CDMA signals, a peak detector is used, with RBW=VBW=3MHz. For AMPS, GSM, and NADC TDMA signals, a peak detector is used, with RBW=VBW=1MHz. A half-wave dipole was substituted in place of the EUT. This dipole antenna was driven by a signal generator and the level of the signal generator was adjusted to obtain the same receive spectrum analyzer reading. This spurious level is recorded. For readings above 1GHz, the above procedure is repeated using horn antennas and the difference between the gain of the horn and an isotropic or dipole antenna are taken into consideration.

6.1 Test Data (Continued)

6.3 CELLULAR CDMA Radiated Measurements

Field Strength of SPURIOUS Radiation

■ OPERATING FREQUENCY:	835.89 MHz
■ CHANNEL:	0363 (Mid)
■ MEASURED OUTPUT POWER:	22.9 dBm = 0.193 W
■ MODULATION SIGNAL:	CDMA (Internal)
■ DISTANCE:	3 meters
■ LIMIT: $43 + 10 \log_{10} (W) =$	35.86 dBc

Freq. (MHz)	LEVEL @ ANTENNA TERMINALS (dBm)	SUBSTITUTE ANTENNA GAIN (dBd)	CORRECT GENERATOR LEVEL (dBm)	POL (H/V)	(dBc)
1671.78	- 65.9	7.3	- 58.6	V	76.2
2507.67	- 63.4	8.3	- 55.1	V	72.2
3343.56	- 68.6	9.7	- 58.9	V	75.1

NOTES:

Radiated Spurious Emission Measurements by Substitution Method

according to ANSI/TIA/EIA-603-A-2001, Aug. 15, 2001:

The EUT was placed on a wooden turn table 3-meters from the receive antenna. The receive antenna height and turntable rotation was adjusted for the highest reading on the receive spectrum analyzer.

For CDMA signals, a peak detector is used, with RBW=VBW=3MHz. For AMPS, GSM, and NADC TDMA signals, a peak detector is used, with RBW=VBW=1MHz. A half-wave dipole was substituted in place of the EUT. This dipole antenna was driven by a signal generator and the level of the signal generator was adjusted to obtain the same receive spectrum analyzer reading. This spurious level is recorded. For readings above 1GHz, the above procedure is repeated using horn antennas and the difference between the gain of the horn and an isotropic or dipole antenna are taken into consideration.

6.1 Test Data (Continued)

6.4 CELLULAR CDMA Radiated Measurements

Field Strength of SPURIOUS Radiation

■ OPERATING FREQUENCY:	848.31 MHz
■ CHANNEL:	0777 (High)
■ MEASURED OUTPUT POWER:	22.9 dBm = 0.193 W
■ MODULATION SIGNAL:	CDMA (Internal)
■ DISTANCE:	3 meters
■ LIMIT: $43 + 10 \log_{10} (W) =$	35.86 dBc

Freq. (MHz)	LEVEL @ ANTENNA TERMINALS (dBm)	SUBSTITUTE ANTENNA GAIN (dBd)	CORRECT GENERATOR LEVEL (dBm)	POL (H/V)	(dBc)
1696.62	- 67.8	7.3	- 60.5	V	78.1
2544.93	- 62.6	8.3	- 54.3	V	71.4
3393.24	- 60.9	9.7	- 51.2	V	67.4

NOTES:

Radiated Spurious Emission Measurements by Substitution Method

according to ANSI/TIA/EIA-603-A-2001, Aug. 15, 2001:

The EUT was placed on a wooden turn table 3-meters from the receive antenna. The receive antenna height and turntable rotation was adjusted for the highest reading on the receive spectrum analyzer.

For CDMA signals, a peak detector is used, with RBW=VBW=3MHz. For AMPS, GSM, and NADC TDMA signals, a peak detector is used, with RBW=VBW=1MHz. A half-wave dipole was substituted in place of the EUT. This dipole antenna was driven by a signal generator and the level of the signal generator was adjusted to obtain the same receive spectrum analyzer reading. This spurious level is recorded. For readings above 1GHz, the above procedure is repeated using horn antennas and the difference between the gain of the horn and an isotropic or dipole antenna are taken into consideration.

7.1 Test Data

7.2 FREQUENCY STABILITY (CDMA)

OPERATING FREQUENCY: 835,890,010 Hz
 CHANNEL: 363
 REFERENCE VOLTAGE: 3.7 VDC
 DEVIATION LIMIT: ± 0.00025 % or 2.5 ppm

Voltage (%)	Power (VDC)	Temp. (°C)	Frequency (Hz)	Deviation (%)	Deviation (ppm)	
100	3.7	+20 (Ref)	835,890,010	0.000000	0.00000	
100		-30	835,890,008	0.000000	0.00239	
100		-20	835,890,015	-0.000001	-0.00598	
100		-10	835,890,013	0.000000	-0.00359	
100		0	835,890,006	0.000000	0.00479	
100		+10	835,890,009	0.000000	0.00120	
100		+20	835,890,010	0.000000	0.00000	
100		+30	835,890,007	0.000000	0.00359	
100		+40	835,890,012	0.000000	-0.00239	
100		+50	835,890,011	0.000000	-0.00120	
100		+60	835,890,013	0.000000	-0.00359	
85		3.15	+20	835,890,010	0.000000	0.00000
115		4.26	+20	835,890,013	0.000000	-0.00359
BATT.END POINT	2.82	+20	835,890,009	0.000000	0.00120	

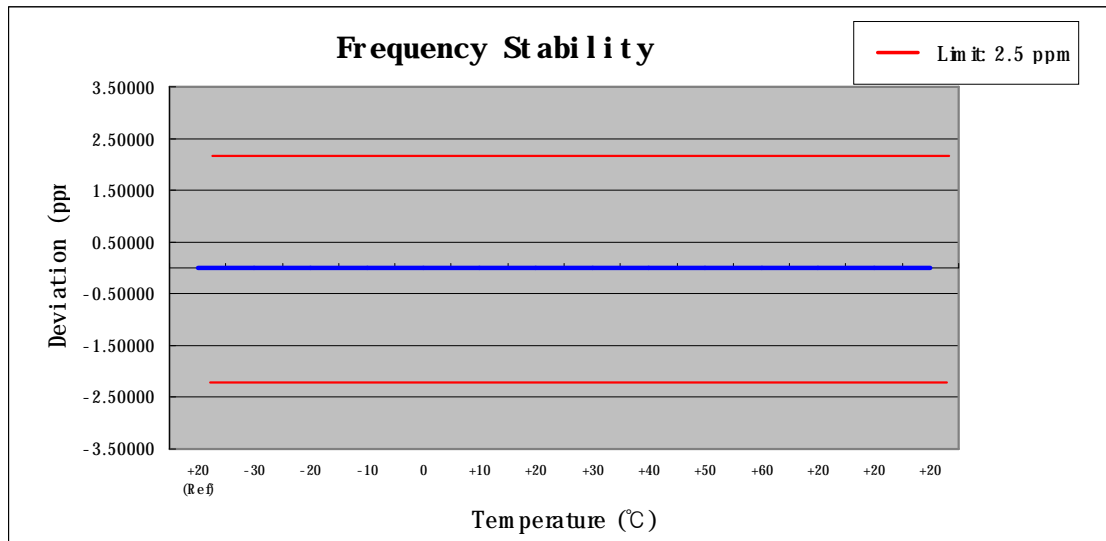

8.1 PLOT(S) OF EMISSION

(SEE ATTACHMENT D)

9.1 LIST OF TEST EQUIPMENT

Name	Model	Serial number	Manufacturer	Date of Calibration
Shielding Room	9.080m×5.255m×3.52 5m	---	FRANKONIA	2004.12.20
Test Receiver	ESCS 30	100029	R&S	2005.8.2
Pulse Limiter	ESH3-Z2	10002	R&S	2005.8.2
Semi-Anechoic Chamber	SAC: 23.18m× 16.88m×9.60m	SAC	FRANKONIA	2004.12.20
Turn Table	Diameter:5m	---	FRANKONIA	---
Antenna Master	MA 260SAC (260/606) SAC(260/607)	---	FRANKONIA	---
EMI Test Receiver	ESI 40	100015	R&S	2005.8.2
Signal Generator	SMR 20	100086	R&S	2004.10.13
Radio Tester	CMU 200	100313	R&S	2005.8.2
Double-Ridged Waveguide Horn Antenna	HF 906	100029	R&S	2005.8.2
Double-Ridged Waveguide Horn Antenna	HF 906	100030	R&S	2005.8.2
GSM Antenna	PSA-75301R/170	401476	European Antennas LTD	---
Fully-Anechoic Chamber	12.65m×8.03m×7.5m	FAC	FRANKONIA	2004.12
Turn Table	PS2000	---	FRANKONIA	---
Antenna Master	MA 260	---	FRANKONIA	---
Climatic Chamber	SH-241	92000389	ESPEC	2005.5.17
Wireless Comm Test Set	E5515C	GB44050904	Agilent	2005.8.2
Spectrum Analyzer	E4440A	MY41000184	Agilent	2005.8.2
EMI Test Software	ES-K1	V1.60	R&S	---
Power Divider	11667A	1736	HP	2005.8.2

10.1 SAMPLE CALCULATIONS

A. ERP Sample Calculation

Freq. Tuned (MHz)	LEVEL(1) (dBm)	POL (H/V)	ERP (W)	ERP(2) (dBm)	BATTERY
824.70	- 29.73	H	0.346	25.393	Standard

- 1) The EUT mounted on a wooden tripod is 0.8 meter above test site ground level.
- 2) During the test the turn table is rotated and the antenna height is also varied from 1 to 4 meters until the maximum signal is found.
- 3) Record the field strength meter's level.(**LEVEL**)
- 4) Replace the EUT with dipole antenna that is connected to a calibrated signal generator.
- 5) Increase the signal generator output till the field strength meter's level is equal to the item (3).
- 6) The signal generator output level with cable loss is the rating of effective radiated power(**ERP**).
(Cable loss means the factor between Signal Generator and Transmitting Antenna.)

For more details, please refer to the test set-up procedure.

B. Emission Designator

Emission Designator = 1M25F9W

CDMA BW = 1.28 MHz

F = Frequency Modulation

9 = Composite Digital Info

W = Combination (Audio/Data)

(Measured at the 99.75% power bandwidth)

11.1 CONCLUSION

The data collected shows that the **Single-Mode CDMA Phone**.

FCC ID: SG70508D1000 complies with all the requirements of Parts 2 and 22 of the FCC rules.