



# RF MEASUREMENT REPORT

---

**FCC ID:** SFKWF196  
**Applicant:** CIG Shanghai Co., Ltd.  
**Product:** Tri-band 4x4 Wi-Fi 6E Wireless AP  
**Model No.:** WF-196, API7340  
**Brand Name:** CIG, Actiontec  
**FCC Classification:** 15E 6GHz Low Power Indoor Access Point (6ID)  
**FCC Rule Part(s):** Part 15 Subpart E (Section 15.407)  
**Result:** Complies  
**Test Date:** 2022-08-05 ~ 2022-08-22

**Reviewed By:**

\_\_\_\_\_  
Kevin Guo

**Approved By:**

\_\_\_\_\_  
Robin Wu



The test results relate only to the samples tested.

This equipment has been shown to be capable of compliance with the applicable technical standards as indicated in the measurement report and was tested in accordance with the measurement procedures specified in KDB789033. Test results reported herein relate only to the item(s) tested.

The test report shall not be reproduced except in full without the written approval of MRT Technology (Suzhou) Co., Ltd.

### Revision History

| Report No.    | Version | Description    | Issue Date | Note  |
|---------------|---------|----------------|------------|-------|
| 2207RSU033-U5 | Rev. 01 | Initial Report | 2022-09-02 | Valid |
|               |         |                |            |       |

CONTENTS

| Description  | Page      |
|--|-----------|
| <b>1. General Information .....</b>                        | <b>6</b>  |
| 1.1. Applicant .....                                       | 6         |
| 1.2. Manufacturer .....                                    | 6         |
| 1.3. Testing Facility .....                                | 6         |
| 1.4. Product Information .....                             | 7         |
| 1.5. Radio Specification under Test .....                  | 7         |
| 1.6. Working Frequencies .....                             | 8         |
| 1.7. Antenna Details .....                                 | 9         |
| <b>2. Test Configuration .....</b>                         | <b>11</b> |
| 2.1. Test Mode .....                                       | 11        |
| 2.2. Test System Connection Diagram .....                  | 11        |
| 2.3. Test Software .....                                   | 12        |
| 2.4. Applied Standards .....                               | 12        |
| 2.5. Test Environment Condition .....                      | 12        |
| <b>3. Antenna Requirements .....</b>                       | <b>13</b> |
| <b>4. Measuring Instrument .....</b>                       | <b>14</b> |
| <b>5. Decision Rules and Measurement Uncertainty .....</b> | <b>15</b> |
| 5.1. Decision Rules .....                                  | 15        |
| 5.2. Measurement Uncertainty .....                         | 15        |
| <b>6. Test Result.....</b>                                 | <b>16</b> |
| 6.1. Summary .....   | 16        |
| 6.2. 26dB & 99% Bandwidth Measurement.....                 | 17        |
| 6.2.1. Test Limit .....                                    | 17        |
| 6.2.2. Test Procedure .....                                | 17        |
| 6.2.3. Test Setting.....                                   | 17        |
| 6.2.4. Test Setup.....                                     | 18        |
| 6.2.5. Test Result.....                                    | 18        |
| 6.3. Output Power Measurement .....                        | 19        |
| 6.3.1. Test Limit .....                                    | 19        |
| 6.3.2. Test Procedure .....                                | 19        |
| 6.3.3. Test Setting.....                                   | 19        |
| 6.3.4. Test Setup.....                                     | 19        |
| 6.3.5. Test Result.....                                    | 19        |
| 6.4. Power Spectral Density Measurement .....              | 20        |
| 6.4.1. Test Limit .....                                    | 20        |
| 6.4.2. Test Procedure .....                                | 20        |

|                                       |  |           |
|---------------------------------------|--|-----------|
| 6.4.3.                                | Test Setting .....                             | 20        |
| 6.4.4.                                | Test Setup.....                                | 20        |
| 6.4.5.                                | Test Result .....                              | 21        |
| 6.5.                                  | In-Band Emission Measurement .....             | 22        |
| 6.5.1.                                | Test Limit .....                               | 22        |
| 6.5.2.                                | Test Procedure .....                           | 22        |
| 6.5.3.                                | Test Setting.....                              | 22        |
| 6.5.4.                                | Test Setup.....                                | 23        |
| 6.5.5.                                | Test Result.....                               | 23        |
| 6.6.                                  | Frequency Stability Measurement.....           | 24        |
| 6.6.1.                                | Test Limit .....                               | 24        |
| 6.6.2.                                | Test Procedure .....                           | 24        |
| 6.6.3.                                | Test Setup.....                                | 24        |
| 6.6.4.                                | Test Result.....                               | 25        |
| 6.7.                                  | Contention Based Protocol Measurement .....    | 26        |
| 6.7.1.                                | Test Limit .....                               | 26        |
| 6.7.2.                                | Test Procedure .....                           | 26        |
| 6.7.3.                                | Test Setting.....                              | 26        |
| 6.7.4.                                | Test Setup.....                                | 27        |
| 6.7.5.                                | Test Result.....                               | 27        |
| 6.8.                                  | Radiated Spurious Emission Measurement .....   | 28        |
| 6.8.1.                                | Test Limit .....                               | 28        |
| 6.8.2.                                | Test Procedure .....                           | 28        |
| 6.8.3.                                | Test Setting.....                              | 29        |
| 6.8.4.                                | Test Setup.....                                | 30        |
| 6.8.5.                                | Test Result.....                               | 31        |
| 6.9.                                  | Radiated Restricted Band Edge Measurement..... | 32        |
| 6.9.1.                                | Test Limit .....                               | 32        |
| 6.9.2.                                | Test Procedure .....                           | 33        |
| 6.9.3.                                | Test Setting.....                              | 33        |
| 6.9.4.                                | Test Setup.....                                | 34        |
| 6.9.5.                                | Test Result.....                               | 34        |
| 6.10.                                 | AC Conducted Emissions Measurement.....        | 35        |
| 6.10.1.                               | Test Limit .....                               | 35        |
| 6.10.2.                               | Test Setup.....                                | 35        |
| 6.10.3.                               | Test Result.....                               | 35        |
| <b>Appendix A – Test Result .....</b> |  | <b>36</b> |
| A.1                                   | Duty Cycle Test Result .....                   | 36        |
| A.2                                   | 26dB & 99% Bandwidth Test Result .....         | 37        |

|   |   |            |
|---|---|------------|
| A.3   | Output Power Test Result .....                  | 48         |
| A.4   | Power Spectral Density Test Result.....         | 50         |
| A.5   | In-Band Emission Measurement .....              | 88         |
| A.6   | Frequency Stability Test Result .....           | 152        |
| A.7   | Contention Based Protocol Test Result.....      | 153        |
| A.8   | Radiated Spurious Emission Test Result .....    | 161        |
| A.9   | Radiated Restricted Band Edge Test Result ..... | 206        |
| A.10  | AC Conducted Emissions Test Result.....         | 238        |
| <b>Appendix B – Test Setup Photograph .....</b> |   | <b>240</b> |
| <b>Appendix C – EUT Photograph .....</b>        |   | <b>241</b> |

## 1. General Information

### 1.1. Applicant

CIG Shanghai Co., Ltd.

5F, Building 8, NO.2388 CHENGHANG ROAD, MINHANG DISTRICT, SHANGHAI

### 1.2. Manufacturer

CIG Shanghai Co., Ltd.

5F, Building 8, NO.2388 CHENGHANG ROAD, MINHANG DISTRICT, SHANGHAI

### 1.3. Testing Facility

|                                     |  |
|-------------------------------------|--|
| <input checked="" type="checkbox"/> | <b>Test Site – MRT Suzhou Laboratory</b>   |
|                                     | <b>Laboratory Location (Suzhou - Wuzhong)</b>  |
|                                     | D8 Building, No.2 Tian'edang Rd., Wuzhong Economic Development Zone, Suzhou, China   |
|                                     | <b>Laboratory Location (Suzhou - SIP)</b>  |
|                                     | 4b Building, Liando U Valley, No.200 Xingpu Rd., Shengpu Town, Suzhou Industrial Park, China   |
|                                     | <b>Laboratory Accreditations</b><br>A2LA: 3628.01 <span style="margin-left: 150px;">CNAS: L10551</span><br>FCC: CN1166 <span style="margin-left: 150px;">ISED: CN0001</span><br>VCCI: <input type="checkbox"/> R-20025 <input type="checkbox"/> G-20034 <input type="checkbox"/> C-20020 <input type="checkbox"/> T-20020<br><input type="checkbox"/> R-20141 <input type="checkbox"/> G-20134 <input type="checkbox"/> C-20103 <input type="checkbox"/> T-20104 |
| <input type="checkbox"/>            | <b>Test Site – MRT Shenzhen Laboratory</b>   |
|                                     | <b>Laboratory Location (Shenzhen)</b>  |
|                                     | 1G, Building A, Junxiangda Building, Zhongshanyuan Road West, Nanshan District, Shenzhen, China  |
|                                     | <b>Laboratory Accreditations</b><br>A2LA: 3628.02 <span style="margin-left: 150px;">CNAS: L10551</span><br>FCC: CN1284 <span style="margin-left: 150px;">ISED: CN0105</span>   |
| <input type="checkbox"/>            | <b>Test Site – MRT Taiwan Laboratory</b>   |
|                                     | <b>Laboratory Location (Taiwan)</b>  |
|                                     | No. 38, Fuxing 2nd Rd., Guishan Dist., Taoyuan City 333, Taiwan (R.O.C.)   |
|                                     | <b>Laboratory Accreditations</b><br>TAF: L3261-190725<br>FCC: 291082, TW3261 <span style="margin-left: 150px;">ISED: TW3261</span>   |

#### 1.4. Product Information

|                         |   |
|-------------------------|---|
| Product Name            | Tri-band 4x4 Wi-Fi 6E Wireless AP   |
| Model No.               | WF-196, API7340   |
| EUT Identification No.  | 20220719Sample#05 (Conducted)<br>20220719Sample#08 (Radiated)   |
| Wi-Fi Specification     | 802.11a/b/g/n/ac/ax   |
| Bluetooth Specification | V5.0 (BLE only)   |
| Antenna Information     | Refer to Section 1.7  |
| Power Type              | AC Adapter Input or PoE Input   |
| Operating Environment   | Indoor Use  |
| Remark:                 | <ol style="list-style-type: none"><li>1. The information of EUT was provided by the manufacturer, and the accuracy of the information shall be the responsibility of the manufacturer.</li><li>2. Different models correspond to different brands, and the others are exactly the same.</li></ol> |

#### 1.5. Radio Specification under Test

|                    |   |
|--------------------|---|
| Frequency Range    | For 802.11ax-HE20: 5955 ~ 7095MHz<br>For 802.11ax-HE40: 5965 ~ 7085MHz<br>For 802.11ax-HE80: 5985 ~ 7025MHz<br>For 802.11ax-HE160: 6025 ~ 6985MHz |
| Type of Modulation | 802.11ax: OFDMA   |
| Data Rate          | 802.11ax: up to 4804Mbps  |

## 1.6. Working Frequencies

### 802.11ax-HE20

| Channel | Frequency | Channel | Frequency | Channel | Frequency |
|---------|-----------|---------|-----------|---------|-----------|
| 01      | 5955 MHz  | 05      | 5975 MHz  | 09      | 5995 MHz  |
| 13      | 6015 MHz  | 17      | 6035 MHz  | 21      | 6055 MHz  |
| 25      | 6075 MHz  | 29      | 6095 MHz  | 33      | 6115 MHz  |
| 37      | 6135 MHz  | 41      | 6155 MHz  | 45      | 6175 MHz  |
| 49      | 6195 MHz  | 53      | 6215 MHz  | 57      | 6235 MHz  |
| 61      | 6255 MHz  | 65      | 6275 MHz  | 69      | 6295 MHz  |
| 73      | 6315 MHz  | 77      | 6335 MHz  | 81      | 6355 MHz  |
| 85      | 6375 MHz  | 89      | 6395 MHz  | 93      | 6415 MHz  |
| 97      | 6435 MHz  | 101     | 6455 MHz  | 105     | 6475 MHz  |
| 109     | 5495 MHz  | 113     | 6515 MHz  | 117     | 6535 MHz  |
| 121     | 6555 MHz  | 125     | 6575 MHz  | 129     | 6595 MHz  |
| 133     | 6615 MHz  | 137     | 6635 MHz  | 141     | 6655 MHz  |
| 145     | 6675 MHz  | 149     | 6695 MHz  | 153     | 6715 MHz  |
| 157     | 6735 MHz  | 161     | 6755 MHz  | 165     | 6775 MHz  |
| 169     | 6795 MHz  | 173     | 6815 MHz  | 177     | 6835 MHz  |
| 181     | 6855 MHz  | 185     | 6875 MHz  | 189     | 6895 MHz  |
| 193     | 6915 MHz  | 197     | 6935 MHz  | 201     | 6955 MHz  |
| 205     | 6975 MHz  | 209     | 6995 MHz  | 213     | 7015 MHz  |
| 217     | 7035 MHz  | 221     | 7055 MHz  | 225     | 7075 MHz  |
| 229     | 7095 MHz  | --      | --        | --      | --        |

### 802.11ax-HE40

| Channel | Frequency | Channel | Frequency | Channel | Frequency |
|---------|-----------|---------|-----------|---------|-----------|
| 03      | 5965 MHz  | 11      | 6005 MHz  | 19      | 6045 MHz  |
| 27      | 6085 MHz  | 35      | 6125 MHz  | 43      | 6165 MHz  |
| 51      | 6205 MHz  | 59      | 6245 MHz  | 67      | 6285 MHz  |
| 75      | 6325 MHz  | 83      | 6365 MHz  | 91      | 6405 MHz  |
| 99      | 6445 MHz  | 107     | 6485 MHz  | 115     | 6525 MHz  |
| 123     | 6565 MHz  | 131     | 6605 MHz  | 139     | 6645 MHz  |
| 147     | 6685 MHz  | 155     | 6725 MHz  | 163     | 6765 MHz  |
| 171     | 6805 MHz  | 179     | 6845 MHz  | 187     | 6885 MHz  |
| 195     | 6925 MHz  | 203     | 6965 MHz  | 211     | 7005 MHz  |
| 219     | 7045 MHz  | 227     | 7085 MHz  | --      | --        |



## 802.11ax-HE80

| Channel | Frequency | Channel | Frequency | Channel | Frequency |
|---------|-----------|---------|-----------|---------|-----------|
| 07      | 5985 MHz  | 23      | 6065 MHz  | 39      | 6145 MHz  |
| 55      | 6225 MHz  | 71      | 6305 MHz  | 87      | 6385 MHz  |
| 103     | 6465 MHz  | 119     | 6545 MHz  | 135     | 6625 MHz  |
| 151     | 6705 MHz  | 167     | 6785 MHz  | 183     | 6865 MHz  |
| 199     | 6945 MHz  | 215     | 7025 MHz  | --      | --        |

## 802.11ax-HE160

| Channel | Frequency | Channel | Frequency | Channel | Frequency |
|---------|-----------|---------|-----------|---------|-----------|
| 15      | 6025 MHz  | 47      | 6185 MHz  | 79      | 6345 MHz  |
| 111     | 6505 MHz  | 143     | 6665 MHz  | 175     | 6825 MHz  |
| 207     | 6985 MHz  | --      | --        | --      | --        |

## 1.7. Antenna Details

| Antenna Type      | Frequency (MHz) | TX Path | Antenna Gain (dBi) |       |       |       | Directional Gain (dBi) |              |
|-------------------|-----------------|---------|--------------------|-------|-------|-------|------------------------|--------------|
|                   |                 |         | Ant 0              | Ant 1 | Ant 2 | Ant 3 | Correlated             | Uncorrelated |
| Wi-Fi Antenna     |                 |         |                    |       |       |       |                        |              |
| PIFA              | 2412 ~ 2462     | 4       | 4.1                | 3.2   | 4.4   | 3.7   | 8.3                    | 2.3          |
|                   | 5150 ~ 5850     | 4       | 4.4                | 4.2   | 3.7   | 4.1   | 9.0                    | 3.0          |
|                   | 5925 ~ 7125     | 4       | 6.6                | 6.2   | 3.3   | 6.1   | 8.8                    | 3.1          |
| Bluetooth Antenna |                 |         |                    |       |       |       |                        |              |
| PIFA              | 2402 ~ 2480     | 1       | 4.2                |       |       |       | --                     |              |

## Remark:

- The antenna gain and directional gain refer to manufacturer's antenna specification.
- The device supports CDD Mode and STBC mode, details refer to the table as below.
- CDD signals are correlated, the directional gain as follows,  
 For power measurements: Array Gain = 0 dB for  $N_{ANT} \leq 4$ , the directional gain = max antenna gain + array gain  
 For power spectral density (PSD) measurements: the max directional gain (each angle) =  $10 \log[(10^{G1/20} + 10^{G2/20} + \dots + 10^{GN/20})^2 / N_{ANT}]$
- STBC signals are uncorrelated, the directional gain as follows,  
 the max directional gain (each angle) =  $10 \log[(10^{G1/10} + 10^{G2/10} + \dots + 10^{GN/10}) / N_{ANT}]$

| Test Mode   | T <sub>x</sub> Paths | CDD Mode | STBC Mode |
|---|----------------------|----------|-----------|
| Wi-Fi 2.4G  |                      |          |           |
| 802.11b/g   | 4                    | √        | X         |
| 802.11n/ax  | 4                    | X        | √         |
| Wi-Fi 5G  |                      |          |           |
| 802.11a   | 4                    | √        | X         |
| 802.11n/ac/ax   | 4                    | X        | √         |
| Wi-Fi 5G  |                      |          |           |
| 802.11ax  | 4                    | X        | √         |
| Remark: "√" means "Support", "X" means "Not support". |                      |          |           |

2.

## 2. Test Configuration

### 2.1. Test Mode

|  |
|--|
| Mode 1: Transmit by 802.11ax-HE20 (MCS11) _ Nss=4 (STBC Mode)  |
| Mode 2: Transmit by 802.11ax-HE40 (MCS11) _ Nss=4 (STBC Mode)  |
| Mode 3: Transmit by 802.11ax-HE80 (MCS11) _ Nss=4 (STBC Mode)  |
| Mode 4: Transmit by 802.11 ax-HE160 (MCS0) _ Nss=4 (STBC Mode)   |
| emark:   |
| 1. For Radiated emission, the modulation and the data rate picked for testing are determined by the Max. RF conducted power. |
| 2. EUT supports one configuration only in 802.11ax full RU mode.   |

### 2.2. Test System Connection Diagram

The device was tested per the guidance ANSI C63.10: 2013 was used to reference the appropriate EUT setup for radiated emissions testing and AC line conducted testing.

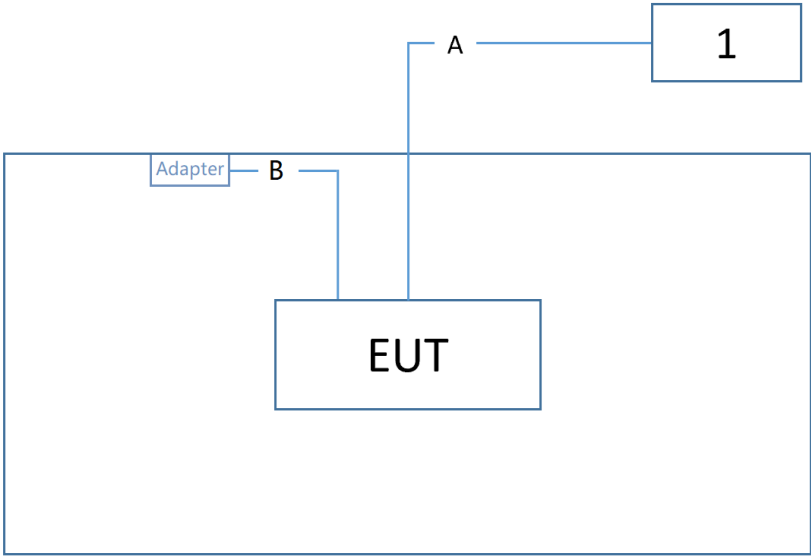
| Connection Diagram – Radiated Emission testing & AC Conducted Emissions              |            |                                    |                  |
|--|------------|------------------------------------|------------------|
|  |            |                                    |                  |
| No.  | Cable Type | Cable Spec.                        | Length           |
| A  | LAN Cable  | Non-Shielded                       | >10 m            |
| B  | LAN Cable  | Non-Shielded                       | 1.2m             |
| No.  | Product    | Manufacturer                       | Model No.        |
| 1  | Adapter    | Shenzhen Honor Electronic Co., Ltd | ADT-38FKJ-PCU00F |
| 2  | Notebook   | Lenovo                             | E431             |

Note: Adapter is provided by manufacturer for test only, it will not be sold with product.

### 2.3. Test Software

The test utility software used during testing was “QRCT”, and the version was 4.0.

### 2.4. Applied Standards

According to the specifications of the manufacturer, the EUT must comply with the requirements of the following standards:

- ANSI C63.10-2013
- FCC KDB 789033 D02v02r01
- FCC KDB 987594 D02v01
- FCC KDB 987594 D04v01
- FCC KDB 662911 D01v02r01
- FCC KDB 414788 D01v01r01
- FCC KDB 412172 D01v01r01

### 2.5. Test Environment Condition

|                     |            |
|---------------------|------------|
| Ambient Temperature | 15 ~ 35°C  |
| Relative Humidity   | 20 ~ 75%RH |

### 3. Antenna Requirements

Excerpt from §15.407(a)(9) of the FCC Rules/Regulations:

Access points operating under the provisions of paragraphs (a)(5) and (a)(6) of this section must employ a permanently attached integrated antenna.

- The antenna of the device is built in and locked inside the enclosure.

#### **Conclusion:**

The device complies with the requirement of §15.407(a)(9).

#### 4. Measuring Instrument

| Instrument                        | Manufacturer | Model No.    | Asset No.   | Cali. Interval | Cali. Due Date | Test Site |
|-----------------------------------|--------------|--------------|-------------|----------------|----------------|-----------|
| USB Power Sensor                  | Keysight     | U2021XA      | MRTSUE06581 | 1 year         | 2023-07-13     | NS-TR2    |
| Thermohygrometer                  | DELI         | NO.8813      | MRTSUE06783 | 1 year         | 2023-04-14     | NS-TR2    |
| Temperature Chamber               | OUKE         | OK-TH-100C   | MRTSUE06899 | 1 year         | 2023-07-13     | NS-TR2    |
| Signal Analyzer                   | Agilent      | N9010A       | MRTSUE06195 | 1 year         | 2023-04-13     | NS-TR2    |
| Signal Analyzer                   | Keysight     | N9020A       | MRTSUE10065 | 1 year         | 2023-01-11     | NS-TR2    |
| Signal Analyzer                   | Agilent      | N9020A       | MRTSUE06106 | 1 year         | 2023-04-06     | WZ-SR5    |
| Thermohygrometer                  | testo        | 608-H1       | MRTSUE06402 | 1 year         | 2023-06-06     | WZ-SR5    |
| Shielding Room                    | HUAMING      | WZ-SR5       | MRTSUE06442 | N/A            | N/A            | WZ-SR5    |
| Signal Analyzer                   | Keysight     | N9010B       | MRTSUE06457 | 1 year         | 2023-06-04     | WZ-SR5    |
| Frequency extender for EXG or MXG | Keysight     | N5182BX07    | MRTSUE06984 | 1 year         | 2023-03-03     | WZ-SR5    |
| Signal Generator                  | Keysight     | N5182B       | MRTSUE06451 | 1 year         | 2023-07-08     | WZ-SR5    |
| Signal Generator                  | Keysight     | N5182B       | MRTSUE06993 | 1 year         | 2022-09-10     | WZ-SR5    |
| EMI Test Receiver                 | R&S          | ESR7         | MRTSUE06001 | 1 year         | 2022-12-29     | WZ-AC1    |
| Horn Antenna                      | Schwarzbeck  | BBHA 9120D   | MRTSUE06023 | 1 year         | 2022-09-16     | WZ-AC1    |
| Preamplifier                      | Agilent      | 83017A       | MRTSUE06076 | 1 year         | 2022-11-12     | WZ-AC1    |
| TRILOG Antenna                    | Schwarzbeck  | VULB 9168    | MRTSUE06172 | 1 year         | 2023-06-21     | WZ-AC1    |
| Anechoic Chamber                  | TDK          | WZ-AC1       | MRTSUE06212 | 1 year         | 2023-04-21     | WZ-AC1    |
| Thermohygrometer                  | testo        | 608-H1       | MRTSUE06403 | 1 year         | 2023-06-06     | WZ-AC1    |
| Signal Analyzer                   | Keysight     | N9010B       | MRTSUE06607 | 1 year         | 2022-12-29     | WZ-AC1    |
| Thermohygrometer                  | testo        | Testo 608-H1 | MRTSUE11039 | 1 year         | 2022-11-11     | WZ-AC1    |
| Horn Antenna                      | Schwarzbeck  | BBHA 9170    | MRTSUE06597 | 1 year         | 2022-12-01     | WZ-AC1    |
| Preamplifier                      | EMCI         | EMC184045SE  | MRTSUE06640 | 1 year         | 2023-01-13     | WZ-AC1    |
| Two-Line V-Network                | R&S          | ENV216       | MRTSUE06002 | 1 year         | 2023-06-04     | WZ-SR2    |
| Shielding Room                    | MIX-BEP      | WZ-SR2       | MRTSUE06215 | N/A            | N/A            | WZ-SR2    |
| Thermohygrometer                  | testo        | 608-H1       | MRTSUE06404 | 1 year         | 2023-06-06     | WZ-SR2    |
| Four-Line V-Network               | R&S          | ENV432       | MRTSUE06615 | 1 year         | 2022-10-13     | WZ-SR2    |
| EMI Test Receiver                 | R&S          | ESR3         | MRTSUE06909 | 1 year         | 2022-11-01     | WZ-SR2    |

| Software             | Version | Function               |
|----------------------|---------|------------------------|
| EMI Software         | V3.0.0  | EMI Test Software      |
| Controller_MF 7802   | 2.03C   | RE Antenna & Turntable |
| BenchVue Power Meter | 2021    | Power                  |

## 5. Decision Rules and Measurement Uncertainty

### 5.1. Decision Rules

The Decision Rule is based on Simple Acceptance in accordance with ISO Guide 98-4: 2012 Clause 8.2. (Measurement uncertainty is not taken into account when stating conformity with a specified requirement.)

### 5.2. Measurement Uncertainty

Where relevant, the following test uncertainty levels have been estimated for tests performed on the EUT as specified in CISPR 16-4-2. This uncertainty represents an expanded uncertainty expressed at approximately the 95% confidence level using a coverage factor of  $k = 2$ .

|  |
|--|
| <b>AC Conducted Emission Measurement</b>   |
| Measurement Uncertainty for a Level of Confidence of 95% ( $U=2Uc(y)$ ):<br>9kHz~150kHz: 3.74dB<br>150kHz~30MHz: 3.44dB  |
| <b>Radiated Disturbance</b>  |
| Measurement Uncertainty for a Level of Confidence of 95% ( $U=2Uc(y)$ ):<br>Horizontal:<br>30MHz~300MHz: 5.04dB<br>300MHz~1GHz: 4.95dB<br>1GHz~40GHz: 6.40dB<br>Vertical:<br>30MHz~300MHz: 5.24dB<br>300MHz~1GHz: 6.03dB<br>1GHz~40GHz: 6.40dB |
| <b>Spurious Emissions, Conducted</b>   |
| Measuring Uncertainty for a Level of Confidence of 95% ( $U=2Uc(y)$ ):<br>0.78dB   |
| <b>Output Power</b>  |
| Measuring Uncertainty for a Level of Confidence of 95% ( $U=2Uc(y)$ ):<br>1.13dB   |
| <b>Power Spectrum Density</b>  |
| Measuring Uncertainty for a Level of Confidence of 95% ( $U=2Uc(y)$ ):<br>1.15dB   |
| <b>Occupied Bandwidth</b>  |
| Measuring Uncertainty for a Level of Confidence of 95% ( $U=2Uc(y)$ ):<br>0.28%  |

## 6. Test Result

### 6.1. Summary

| FCC Section(s)          | Test Description  | Test Condition | Verdict |
|-------------------------|---|----------------|---------|
| 15.407(a)               | 26dB Bandwidth  | Conducted      | Pass    |
| 15.407(a)(5), (a)(6)    | Maximum Equivalent Isotropically Radiated Power (E.I.R.P)       |                | Pass    |
| 15.407(a)(5), (a)(6)    | Peak Power Spectral Density (E.I.R.P)                           |                | Pass    |
| 15.407(b)(7)            | In-Band Emission  |                | Pass    |
| 15.407(g)               | Frequency Stability   |                | Pass    |
| 15.407(d)(6)            | Contention-Based Protocol                                       |                | Pass    |
| 15.407(b)(6)            | Unwanted Emissions  | Radiated       | Pass    |
| 15.407(b)(8), (9), (10) | General Field Strength (Restricted Bands and Radiated Emission) |                | Pass    |
| 15.207                  | AC Conducted Emissions<br>150kHz - 30MHz                        | Line Conducted | Pass    |

**Remark:**

1. The analyzer plots shown in this section were all taken with a correction table loaded into the analyzer. The correction table was used to account for the losses of the cables and attenuators used as part of the system to connect the EUT to the analyzer at all frequencies of interest.
2. Output power test was verified over all data rates of each mode, and then choose the maximum power output for final test of each channel.
3. For radiated emission test, every axis (X, Y, Z) was also verified. The test results shown in the following sections represent the worst-case emissions.



## 6.2. 26dB & 99% Bandwidth Measurement

### 6.2.1. Test Limit

N/A

### 6.2.2. Test Procedure

KDB 789033 D02v02r01- Section II)C)1) (26dB Bandwidth)

KDB 789033 D02v02r01- Section II)D) (99% Bandwidth)

### 6.2.3. Test Setting

#### 26dB Bandwidth

1. The analyzers' automatic bandwidth measurement capability was used to perform the 26dB bandwidth
2. RBW = approximately 1% of the emission bandwidth.
3. VBW > RBW
4. Detector = Peak.
5. Trace mode = max hold.
6. Measure the maximum width of the emission that is 26 dB down from the maximum of the emission.  
Compare this with the RBW setting of the analyzer. Readjust RBW and repeat measurement as needed until the RBW/EBW ratio is approximately 1%.

#### 99% Bandwidth

1. Set center frequency to the nominal EUT channel center frequency.
2. RBW = 1% to 5% of the OBW
3. VBW  $\geq 3 \times$  RBW
4. Span = 1.5 times to 5 times the OBW
5. Detector = peak
6. Trace mode = max hold
7. Allow the trace to stabilize
8. Use the 99% power bandwidth function of the instrument.

#### 6.2.4. Test Setup

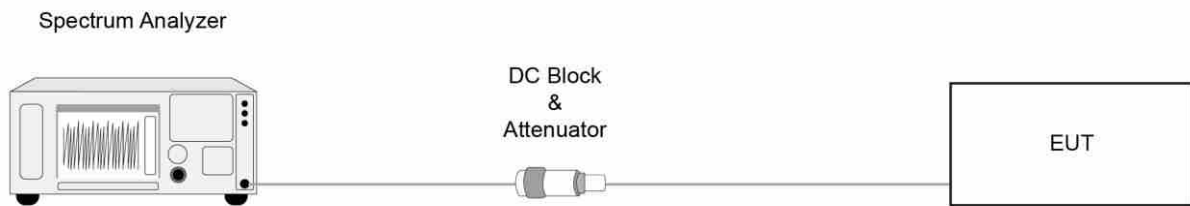

#### 6.2.5. Test Result

Refer to Appendix A.2.

### 6.3. Output Power Measurement

#### 6.3.1. Test Limit

For an indoor access point operating in the 5.925-7.125 GHz band, the maximum e.i.r.p. over the frequency band of operation must not exceed 30 dBm.

#### 6.3.2. Test Procedure

KDB 789033D02v02r01- Section II)E)3)b) Method PM-G

#### 6.3.3. Test Setting

##### Average Power Measurement

Average power measurements were performed only when the EUT was transmitting at its maximum power control level using a broadband power meter with a pulse sensor. The power meter implemented triggering and gating capabilities which were set up such that power measurements were recorded only during the ON time of the transmitter.

#### 6.3.4. Test Setup



#### 6.3.5. Test Result

Refer to Appendix A.3.

## 6.4. Power Spectral Density Measurement

### 6.4.1. Test Limit

For an indoor access point operating in the 5.925-7.125 GHz band, the maximum power spectral density must not exceed 5 dBm e.i.r.p. in any 1-megahertz band.

### 6.4.2. Test Procedure

KDB 789033 D02v02r01-Section II)F)

### 6.4.3. Test Setting

1. Analyzer was set to the center frequency of the UNII channel under investigation
2. Span was set to encompass the entire 26dB EBW of the signal.
3. RBW = 1MHz
4. VBW = 3MHz
5. Number of sweep points  $\geq 2 \times (\text{span} / \text{RBW})$
6. Detector = power averaging (Average)
7. Sweep time = auto
8. Trigger = free run
9. Trace average at least 100 traces in power averaging (rms) mode; however, the number of traces to be averaged shall be increased above 100 as needed to ensure that the average accurately represents the true average over the on and off periods of the transmitter.
10. Use the peak search function on the instrument to find the peak of the spectrum and record its value.
11. Add  $10 \cdot \log(1/x)$ , where  $x$  is the duty cycle, to the measured power in order to compute the average power during the actual transmission times (because the measurement represents an average over both the on and off times of the transmission). For example, add  $10 \cdot \log(1/0.25) = 6$  dB if the duty cycle is 25 percent.

### 6.4.4. Test Setup

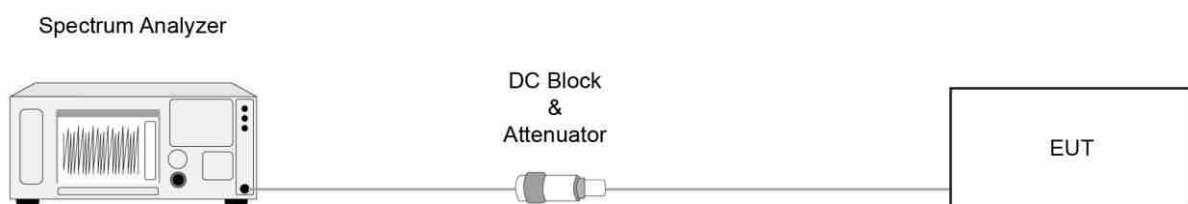

#### **6.4.5. Test Result**

Refer to Appendix A.4.

## 6.5. In-Band Emission Measurement

### 6.5.1. Test Limit

Suppressed by 20 dB at 1 MHz outside of the channel edge. (The channel edge is defined as the 26-dB point on either side of the carrier center frequency.)

Suppressed by 28 dB at one channel bandwidth from the channel center.

Suppressed by 40 dB at one- and one-half times the channel bandwidth from the channel center.

### 6.5.2. Test Procedure

KDB 987594 D02v01r01- Section J

### 6.5.3. Test Setting

#### Emissions Mask Reference Level Measurement

1. Set the span to encompass the entire 26 dB EBW of the signal.
2. Set RBW = same RBW used for 26 dB EBW measurement.
3. Set VBW  $\geq 3 \times$  RBW.
4. Number of points in sweep  $\geq [2 \times \text{span} / \text{RBW}]$ .
5. Sweep time = auto.
6. Detector = RMS.
7. Trace average at least 100 traces in power averaging (rms) mode.
8. Use the peak search function on the instrument to find the peak of the spectrum.

#### In-Band Emission

1. Using the measuring equipment limit line function, develop the emissions mask based on rule.
2. Adjust the span to encompass the entire mask as necessary.
3. Clear trace.
4. Trace average at least 100 traces in power averaging (rms) mode.
5. Adjust the reference level as necessary so that the crest of the channel touches the top of the emission mask.

#### 6.5.4. Test Setup

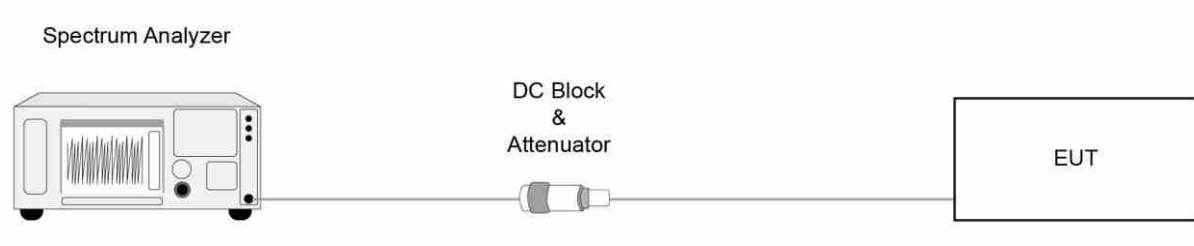

#### 6.5.5. Test Result

Refer to Appendix A.5.

## 6.6. Frequency Stability Measurement

### 6.6.1. Test Limit

Manufactures of U-NII devices are responsible for ensuring frequency stability such that an emission is maintained within the band of operation under all conditions of normal operation as specified in the user's manual.

### 6.6.2. Test Procedure

#### Frequency Stability Under Temperature Variations:

The equipment under test was connected to an external AC or DC power supply and input rated voltage. RF output was connected to a frequency counter or spectrum analyzer via feed through attenuators. The EUT was placed inside the temperature chamber. Set the spectrum analyzer RBW low enough to obtain the desired frequency resolution and measure EUT 20°C operating frequency as reference frequency. Turn EUT off and set the chamber temperature to highest. After the temperature stabilized for approximately 30 minutes recorded the frequency. Repeat step measure with 10°C decreased per stage until the lowest temperature reached.

#### Frequency Stability Under Voltage Variations:

Set chamber temperature to 20°C. Use a variable AC power supply / DC power source to power the EUT and set the voltage to rated voltage. Set the spectrum analyzer RBW low enough to obtain the desired frequency resolution and recorded the frequency.

Reduce the input voltage to specify extreme voltage variation ( $\pm 15\%$ ) and endpoint, record the maximum frequency change.

### 6.6.3. Test Setup

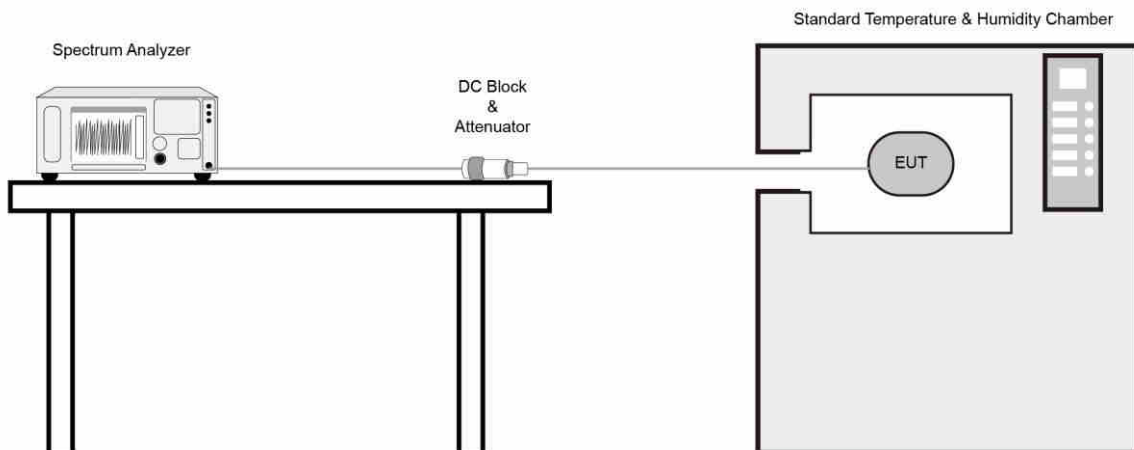



#### **6.6.4. Test Result**

Refer to Appendix A.6.

## **6.7. Contention Based Protocol Measurement**

### **6.7.1. Test Limit**

Unlicensed indoor low power device must detect co-channel radio frequency power that is at least -62dBm (The threshold is referenced to a 0dBi antenna gain.) or low.

Indoor low power device must detect an AWGN signal with 90% (or better) level of certainty.

### **6.7.2. Test Procedure**

KDB 987594 D02v01- Section I

### **6.7.3. Test Setting**

1. Configure the EUT to transmit with a constant duty cycle.
2. Set the operating parameters of the EUT including power level, operating frequency, modulation and bandwidth.
3. Set the signal analyzer center frequency to the nominal EUT channel center frequency. The span range of the signal analyzer shall be between two times and five times the OBW of the EUT.  
Connect the output port of the EUT to the signal analyzer 2. Ensure that the attenuator 2 provides enough attenuation to not overload the signal analyzer 2 receiver.
4. Monitoring the signal analyzer 2, verify the EUT is operating and transmitting with the parameters set at step two.
5. Using an AWGN signal source, generate a 10 MHz-wide AWGN signal. Use Table 1 of KDB 987594 to determine the center frequency of the 10 MHz AWGN signal relative to the EUT's channel bandwidth and center frequency.
6. Set the AWGN signal power to an extremely low level. Connect the AWGN signal source, via a 3-dB splitter, to the signal analyzer 1 and the EUT as shown in below figure.
7. Transmit the AWGN signal (RF ON) and verify its characteristics on the signal analyzer 1.
8. Monitor the signal analyzer 2 to verify if the AWGN signal has been detected and the EUT has ceased transmission. If the EUT continues to transmit, then incrementally increase the AWGN signal power level until the EUT stops transmitting.
9. Determine and record the AWGN signal power level (at the EUT's antenna port) at which the EUT ceased transmission. Repeat the procedure at least 10 times to verify the EUT can detect an AWGN signal with 90% (or better) level of certainty.
10. Refer to Table 1 to determine number of times the detection threshold testing needs to be

repeated. If testing is required more than once, then go back to step 5, choose a different center frequency for the AWGN signal and repeat the process.

#### 6.7.4. Test Setup

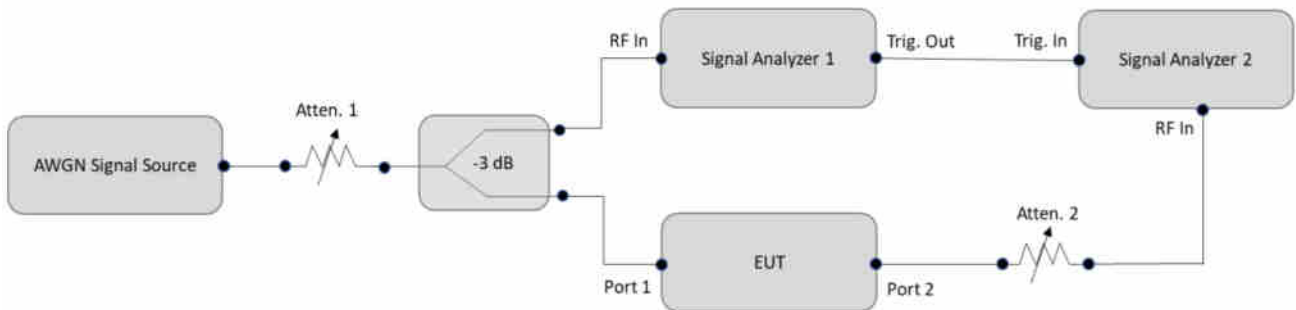

#### 6.7.5. Test Result

Refer to Appendix A.7.

## 6.8. Radiated Spurious Emission Measurement

### 6.8.1. Test Limit

For 15.407(b)(5) requirement

For transmitters operating within the 5.925-7.125 GHz band: Any emissions outside of the 5.925-7.125 GHz band must not exceed an e.i.r.p. of  $-27$  dBm/MHz.

Refer to 987594 D02 U-NII 6GHz EMC Measurement v01 clause G

Use guidance in KDB 789033 for measurements below 1000 MHz and above 1000 MHz. Unwanted emissions outside of restricted bands are measured with a RMS detector. In addition, 15.35(b) applies where the peak emissions must be limited to no more than 20 dB above the average limit.

All out of band emissions appearing in a restricted band as specified in Section 15.205 of the Title 47CFR must not exceed the limits shown in Table per Section 15.209.

| FCC Part 15 Subpart C Paragraph 15.209 |                             |                            |
|--|-----------------------------|----------------------------|
| Frequency [MHz]                        | Field Strength [ $\mu$ V/m] | Measured Distance [Meters] |
| 0.009 - 0.490                          | 2400/F (kHz)                | 300                        |
| 0.490 - 1.705                          | 24000/F (kHz)               | 30                         |
| 1.705 - 30                             | 30                          | 30                         |
| 30 - 88                                | 100                         | 3                          |
| 88 - 216                               | 150                         | 3                          |
| 216 - 960                              | 200                         | 3                          |
| Above 960                              | 500                         | 3                          |

### 6.8.2. Test Procedure

KDB 789033 D02v02r01-Section II)G)

### 6.8.3. Test Setting

**Table 1 - RBW as a function of frequency**

| Frequency     | RBW           |
|---------------|---------------|
| 9 ~ 150 kHz   | 200 ~ 300 Hz  |
| 0.15 ~ 30 MHz | 9 ~ 10 kHz    |
| 30 ~ 1000 MHz | 100 ~ 120 kHz |
| > 1000MHz     | 1MHz          |

#### **Quasi-Peak Measurements below 1GHz**

1. Analyzer center frequency was set to the frequency of the radiated spurious emission of interest
2. Span was set greater than 1MHz
3. RBW = as specified in Table 1
4. Detector = CISPR quasi-peak
5. Sweep time = auto couple
6. Trace was allowed to stabilize

#### **Peak Measurements above 1GHz**

1. Analyzer center frequency was set to the frequency of the radiated spurious emission of interest
2. RBW = 1MHz
3. VBW = 3MHz
4. Detector = peak
5. Sweep time = auto couple
6. Trace mode = max hold
7. Trace was allowed to stabilize

#### **Average Measurements above 1GHz (Method VB)**

1. Analyzer center frequency was set to the frequency of the radiated spurious emission of interest
2. RBW = 1MHz
3. VBW; If the EUT is configured to transmit with duty cycle  $\geq 98\%$ , set VBW = 10 Hz.  
If the EUT duty cycle is  $< 98\%$ , set VBW  $\geq 1/T$ . T is the minimum transmission duration.
4. Detector = Peak
5. Sweep time = auto
6. Trace mode = max hold

7. Trace was allowed to stabilize

### 6.8.4. Test Setup

Below 1GHz Test Setup:

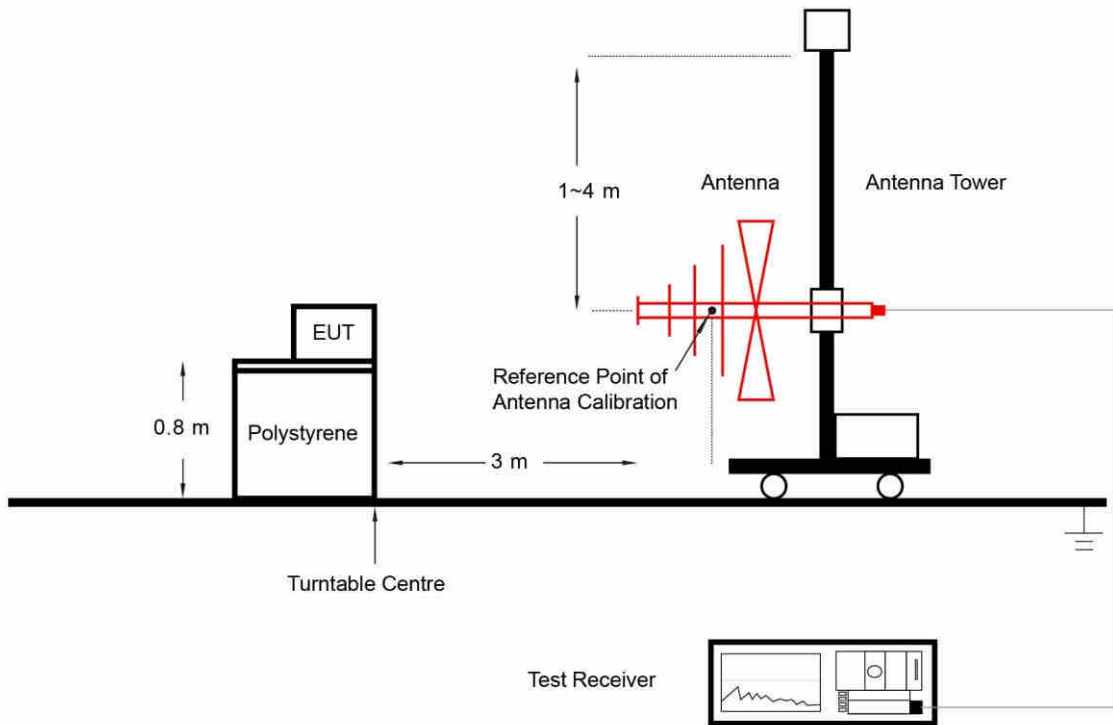

Above 1GHz Test Setup:

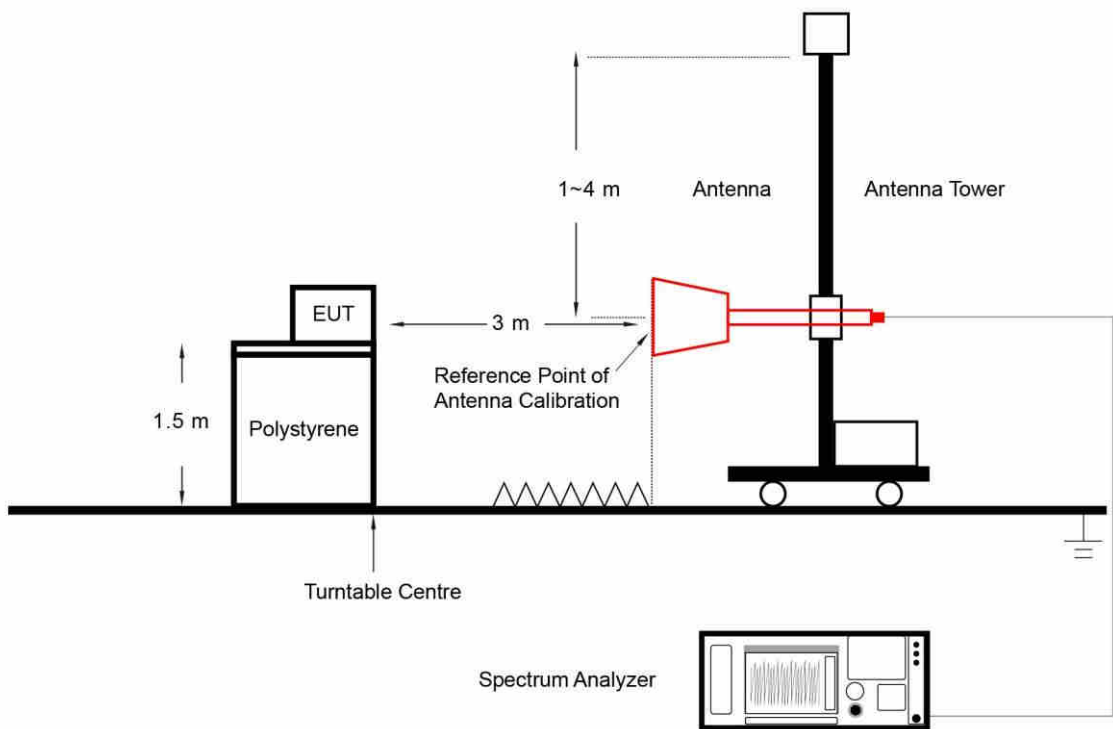

### **6.8.5. Test Result**

Refer to Appendix A.8.

## 6.9. Radiated Restricted Band Edge Measurement

### 6.9.1. Test Limit

#### **For 15.205 requirement:**

Radiated emissions which fall in the restricted bands, as defined in Section 15.205(a) of FCC part 15, must also comply with the radiated emission limits specified in Section 15.209(a).

| Frequency<br>(MHz)         | Frequency<br>(MHz)    | Frequency<br>(MHz) | Frequency<br>(GHz) |
|----------------------------|-----------------------|--------------------|--------------------|
| 0.090 - 0.110              | 16.42 - 16.423        | 399.9 - 410        | 4.5 - 5.15         |
| <sup>1</sup> 0.495 - 0.505 | 16.69475 - 16.69525   | 608 - 614          | 5.35 - 5.46        |
| 2.1735 - 2.1905            | 16.80425 - 16.80475   | 960 - 1240         | 7.25 - 7.75        |
| 4.125 - 4.128              | 25.5 - 25.67          | 1300 - 1427        | 8.025 - 8.5        |
| 4.17725 - 4.17775          | 37.5 - 38.25          | 1435 - 1626.5      | 9.0 - 9.2          |
| 4.20725 - 4.20775          | 73 - 74.6             | 1645.5 - 1646.5    | 9.3 - 9.5          |
| 6.215 - 6.218              | 74.8 - 75.2           | 1660 - 1710        | 10.6 - 12.7        |
| 6.26775 - 6.26825          | 108 - 121.94          | 1718.8 - 1722.2    | 13.25 - 13.4       |
| 6.31175 - 6.31225          | 123 - 138             | 2200 - 2300        | 14.47 - 14.5       |
| 8.291 - 8.294              | 149.9 - 150.05        | 2310 - 2390        | 15.35 - 16.2       |
| 8.362 - 8.366              | 156.52475 - 156.52525 | 2483.5 - 2500      | 17.7 - 21.4        |
| 8.37625 - 8.38675          | 156.7 - 156.9         | 2690 - 2900        | 22.01 - 23.12      |
| 8.41425 - 8.41475          | 162.0125 - 167.17     | 3260 - 3267        | 23.6 - 24.0        |
| 12.29 - 12.293             | 167.72 - 173.2        | 3332 - 3339        | 31.2 - 31.8        |
| 12.51975 - 12.52025        | 240 - 285             | 3345.8 - 3358      | 36.43 - 36.5       |
| 12.57675 - 12.57725        | 322 - 335.4           | 3600 - 4400        | ( <sup>2</sup> )   |
| 13.36 - 13.41              | --                    | --                 | --                 |



**For 15.407(b)(5) requirement:**

For transmitters operating within the 5.925-7.125 GHz band: Any emissions outside of the 5.925-7.125 GHz band must not exceed an e.i.r.p. of -27 dBm/MHz.

Refer to 987594 D02 U-NII 6GHz EMC Measurement v01 clause G - Unwanted Emission Measurement

Use guidance in KDB 789033 for measurements below 1000 MHz and above 1000 MHz. Unwanted emissions outside of restricted bands are measured with a RMS detector. In addition, 15.35(b) applies where the peak emissions must be limited to no more than 20 dB above the average limit.

All out of band emissions appearing in a restricted band as specified in Section 15.205 of the Title 47CFR must not exceed the limits shown in Table per Section 15.209.

| FCC Part 15 Subpart C Paragraph 15.209 |                          |                               |
|--|--------------------------|-------------------------------|
| Frequency<br>[MHz]                     | Field Strength<br>[uV/m] | Measured Distance<br>[Meters] |
| 0.009 - 0.490                          | 2400/F (kHz)             | 300                           |
| 0.490 - 1.705                          | 24000/F (kHz)            | 30                            |
| 1.705 - 30                             | 30                       | 30                            |
| 30 - 88                                | 100                      | 3                             |
| 88 - 216                               | 150                      | 3                             |
| 216 - 960                              | 200                      | 3                             |
| Above 960                              | 500                      | 3                             |

**6.9.2. Test Procedure**

KDB 789033 D02v02r01-Section II)G)

**6.9.3. Test Setting**

**Peak Measurements above 1GHz**

1. Analyzer center frequency was set to the frequency of the radiated spurious emission of interest
2. RBW = 1MHz
3. VBW = 3MHz
4. Detector = Peak
5. Sweep time = Auto couple
6. Trace mode = Max hold

7. Trace was allowed to stabilize

#### **Average Measurements above 1GHz (Method VB)**

1. Analyzer center frequency was set to the frequency of the radiated spurious emission of interest
2. RBW = 1MHz
3. VBW; if the EUT is configured to transmit with duty cycle  $\geq 98\%$ , set VBW = 10Hz
4. If the EUT duty cycle is  $< 98\%$ , set VBW  $\geq 1/T$ . T is the minimum transmission duration
5. Detector = Peak
6. Sweep time = Auto
7. Trace mode = Max hold
8. Trace was allowed to stabilize

#### **6.9.4. Test Setup**

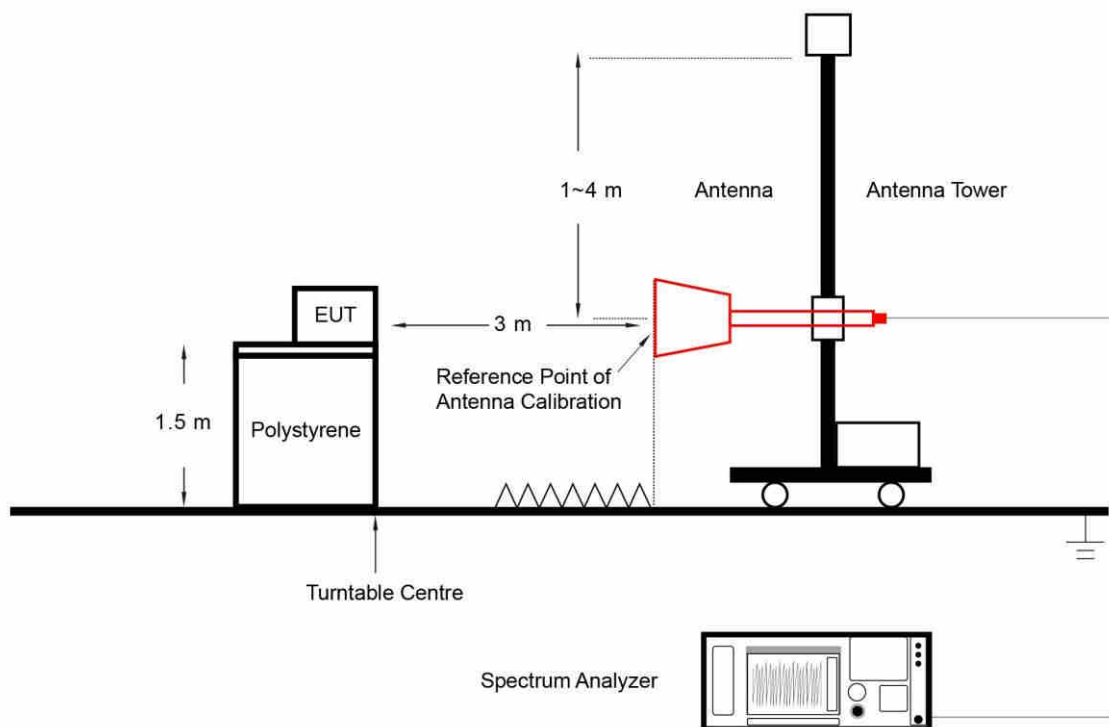

#### **6.9.5. Test Result**

Refer to Appendix A.9.

## 6.10. AC Conducted Emissions Measurement

### 6.10.1. Test Limit

| FCC Part 15.207 Limits |                 |                 |
|------------------------|-----------------|-----------------|
| Frequency (MHz)        | QP (dB $\mu$ V) | AV (dB $\mu$ V) |
| 0.15 - 0.50            | 66 - 56         | 56 - 46         |
| 0.50 - 5.0             | 56              | 46              |
| 5.0 - 30               | 60              | 50              |

Note 1: The lower limit shall apply at the transition frequencies.

Note 2: The limit decreases linearly with the logarithm of the frequency in the range 0.15MHz to 0.5MHz.

### 6.10.2. Test Setup

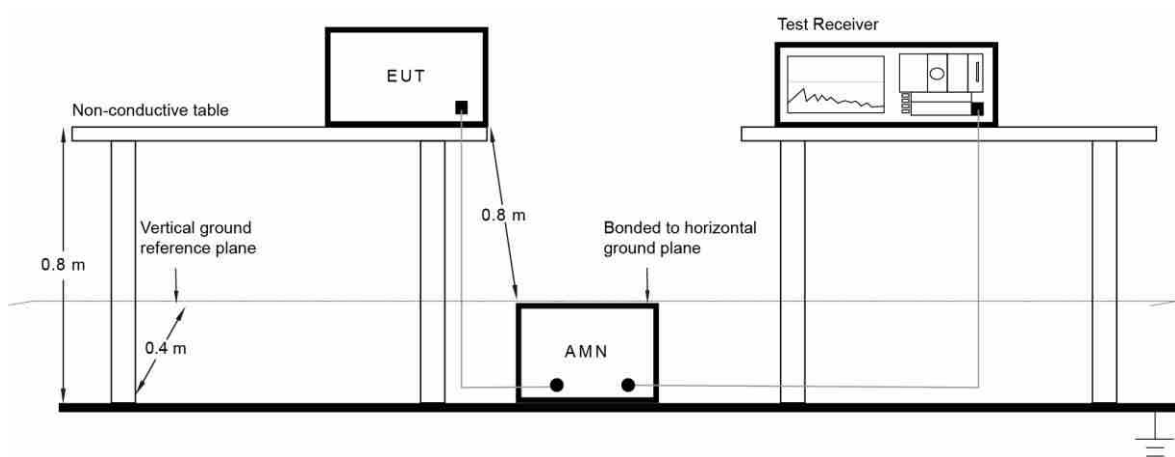

### 6.10.3. Test Result

Refer to Appendix A.10.

## Appendix A – Test Result

### A.1 Duty Cycle Test Result

| Test Mode      | Duty Cycle |
|----------------|------------|
| 802.11ax-HE20  | 85.55%     |
| 802.11ax-HE40  | 93.77%     |
| 802.11ax-HE80  | 92.56%     |
| 802.11ax-HE160 | 93.32%     |

Duty Cycle (T = Transmission Duration)

802.11ax-HE20 (T = 5.415ms)

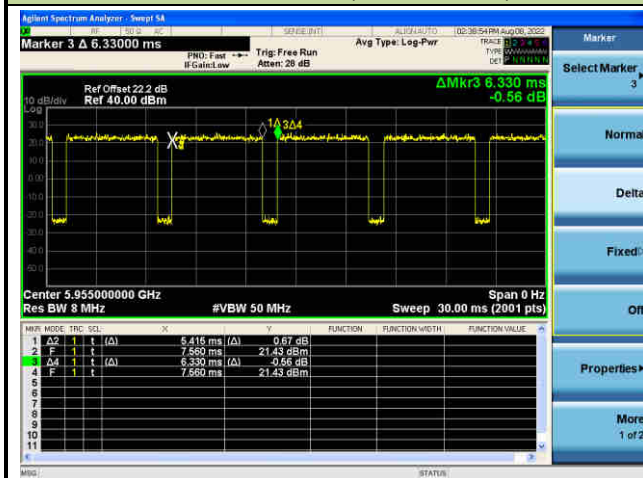

802.11ax-HE40 (T = 5.415ms)

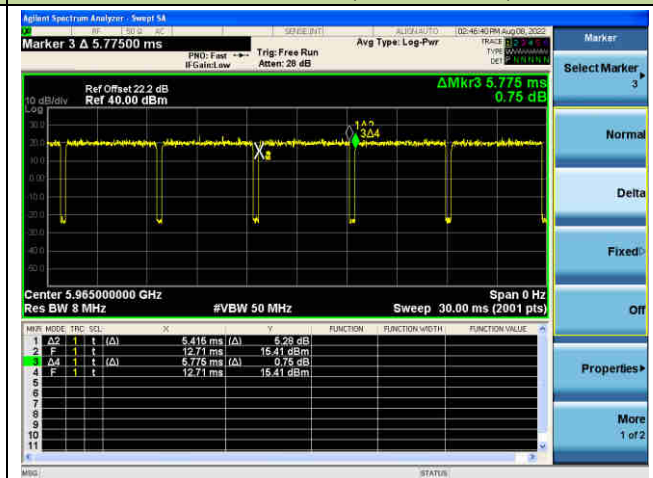

802.11ax-HE80 (T = 5.415ms)

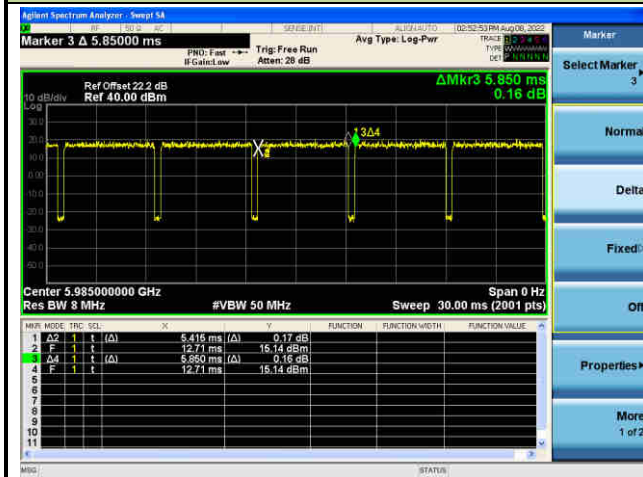

802.11ax-HE160 (T = 5.445ms)

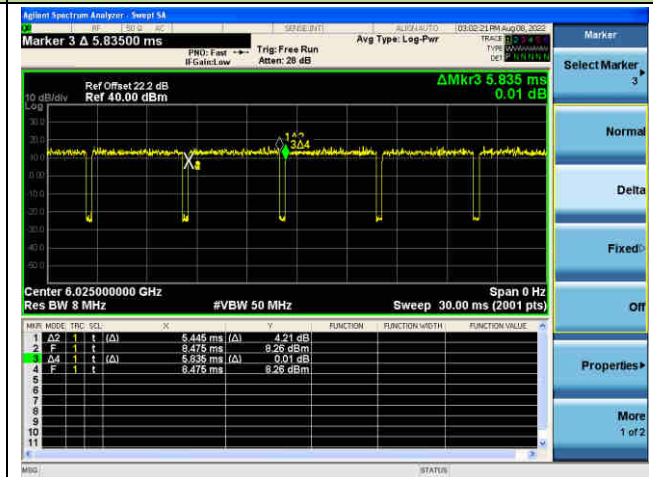

**A.2 26dB & 99% Bandwidth Test Result**

|           |            |               |             |
|-----------|------------|---------------|-------------|
| Test Site | NS-TR2     | Test Engineer | Summer Tang |
| Test Date | 2022-08-10 |               |             |

| Test Mode     | Data Rate/<br>MCS | Channel No. | Frequency<br>(MHz) | 26dB Bandwidth<br>(MHz) | 99% Bandwidth<br>(MHz) |
|---------------|-------------------|-------------|--------------------|-------------------------|------------------------|
| 802.11ax-HE20 | MCS11             | 1           | 5955               | 21.84                   | 19.035                 |
| 802.11ax-HE20 | MCS11             | 49          | 6195               | 21.69                   | 19.033                 |
| 802.11ax-HE20 | MCS11             | 93          | 6415               | 21.64                   | 19.057                 |
| 802.11ax-HE20 | MCS11             | 97          | 6435               | 21.82                   | 19.012                 |
| 802.11ax-HE20 | MCS11             | 105         | 6475               | 21.54                   | 19.052                 |
| 802.11ax-HE20 | MCS11             | 113         | 6515               | 21.48                   | 19.042                 |
| 802.11ax-HE20 | MCS11             | 117         | 6535               | 21.59                   | 19.056                 |
| 802.11ax-HE20 | MCS11             | 149         | 6695               | 21.51                   | 19.030                 |
| 802.11ax-HE20 | MCS11             | 181         | 6855               | 21.82                   | 19.044                 |
| 802.11ax-HE20 | MCS11             | 185         | 6875               | 21.60                   | 19.018                 |
| 802.11ax-HE20 | MCS11             | 189         | 6895               | 21.56                   | 19.004                 |
| 802.11ax-HE20 | MCS11             | 209         | 6995               | 21.93                   | 19.032                 |
| 802.11ax-HE20 | MCS11             | 229         | 7095               | 21.65                   | 19.043                 |
| 802.11ax-HE40 | MCS11             | 3           | 5965               | 42.81                   | 37.916                 |
| 802.11ax-HE40 | MCS11             | 51          | 6205               | 43.04                   | 38.002                 |
| 802.11ax-HE40 | MCS11             | 91          | 6405               | 43.17                   | 37.916                 |
| 802.11ax-HE40 | MCS11             | 99          | 6445               | 42.80                   | 37.881                 |
| 802.11ax-HE40 | MCS11             | 107         | 6485               | 42.72                   | 37.867                 |
| 802.11ax-HE40 | MCS11             | 115         | 6525               | 42.18                   | 37.927                 |
| 802.11ax-HE40 | MCS11             | 123         | 6565               | 42.40                   | 37.902                 |
| 802.11ax-HE40 | MCS11             | 147         | 6685               | 42.38                   | 37.920                 |
| 802.11ax-HE40 | MCS11             | 187         | 6885               | 42.79                   | 37.891                 |
| 802.11ax-HE40 | MCS11             | 195         | 6925               | 43.06                   | 37.954                 |
| 802.11ax-HE40 | MCS11             | 211         | 7005               | 42.44                   | 37.936                 |
| 802.11ax-HE40 | MCS11             | 227         | 7085               | 42.42                   | 37.919                 |

| Test Mode      | Data Rate/<br>MCS | Channel No. | Frequency<br>(MHz) | 26dB Bandwidth<br>(MHz) | 99% Bandwidth<br>(MHz) |
|----------------|-------------------|-------------|--------------------|-------------------------|------------------------|
| 802.11ax-HE80  | MCS11             | 7           | 5985               | 87.48                   | 77.578                 |
| 802.11ax-HE80  | MCS11             | 55          | 6225               | 88.54                   | 77.693                 |
| 802.11ax-HE80  | MCS11             | 87          | 6385               | 88.75                   | 77.691                 |
| 802.11ax-HE80  | MCS11             | 103         | 6465               | 88.77                   | 77.676                 |
| 802.11ax-HE80  | MCS11             | 119         | 6545               | 88.39                   | 77.718                 |
| 802.11ax-HE80  | MCS11             | 135         | 6625               | 90.03                   | 77.729                 |
| 802.11ax-HE80  | MCS11             | 151         | 6705               | 87.72                   | 77.637                 |
| 802.11ax-HE80  | MCS11             | 167         | 6785               | 87.42                   | 77.730                 |
| 802.11ax-HE80  | MCS11             | 183         | 6865               | 88.08                   | 77.540                 |
| 802.11ax-HE80  | MCS11             | 199         | 6945               | 87.97                   | 77.615                 |
| 802.11ax-HE80  | MCS11             | 215         | 7025               | 88.67                   | 77.659                 |
| 802.11ax-HE160 | MCS0              | 15          | 6025               | 165.80                  | 154.61                 |
| 802.11ax-HE160 | MCS0              | 47          | 6185               | 163.60                  | 154.44                 |
| 802.11ax-HE160 | MCS0              | 79          | 6345               | 162.30                  | 154.80                 |
| 802.11ax-HE160 | MCS0              | 111         | 6505               | 163.80                  | 154.63                 |
| 802.11ax-HE160 | MCS0              | 143         | 6665               | 163.30                  | 154.52                 |
| 802.11ax-HE160 | MCS0              | 175         | 6825               | 163.30                  | 154.88                 |
| 802.11ax-HE160 | MCS0              | 207         | 6985               | 164.00                  | 153.89                 |

## 802.11ax-HE20 26dB Bandwidth

## Channel 1 (5955MHz)



## Channel 49 (6195MHz)



## Channel 93 (6415MHz)

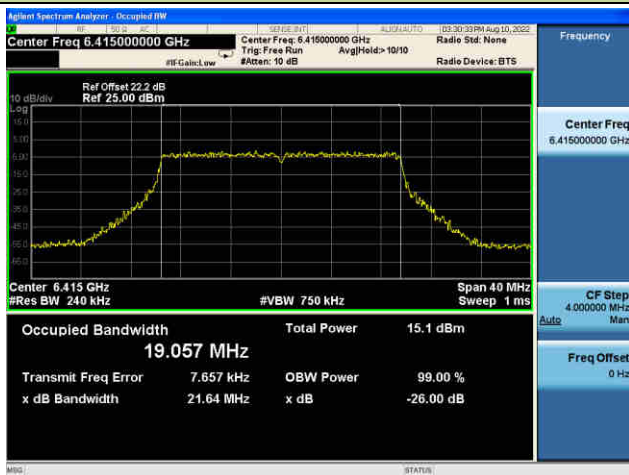

## Channel 97 (6435MHz)

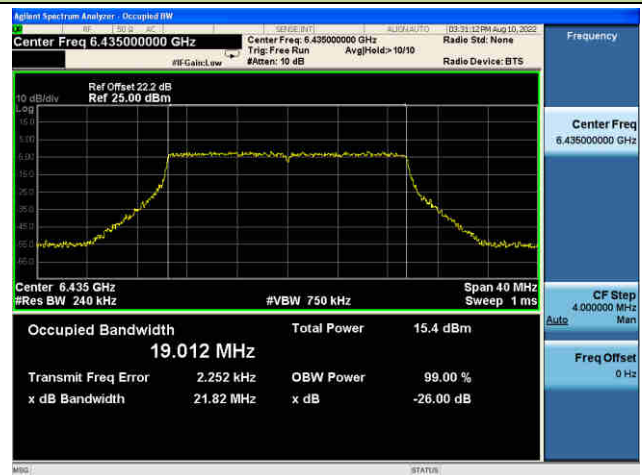

## Channel 105 (6475MHz)

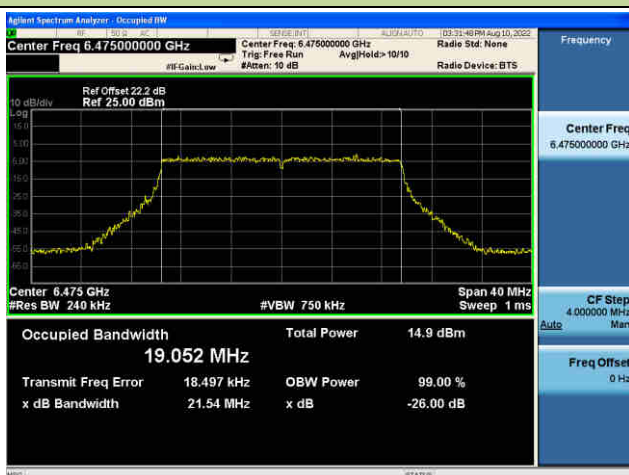

## Channel 113 (6515MHz)

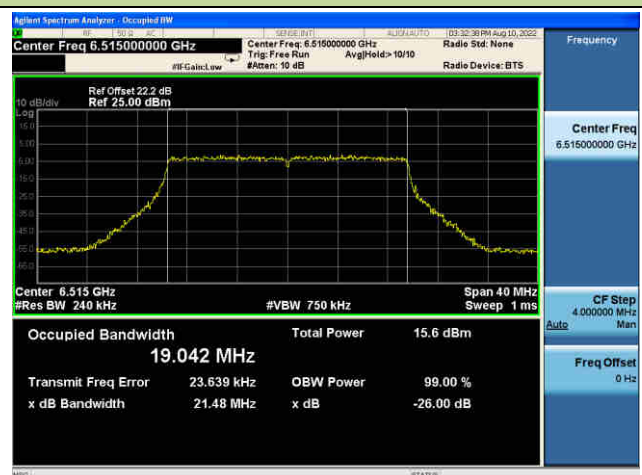

## 802.11ax-HE20 26dB Bandwidth

## Channel 117 (6535MHz)



## Channel 149 (6695MHz)

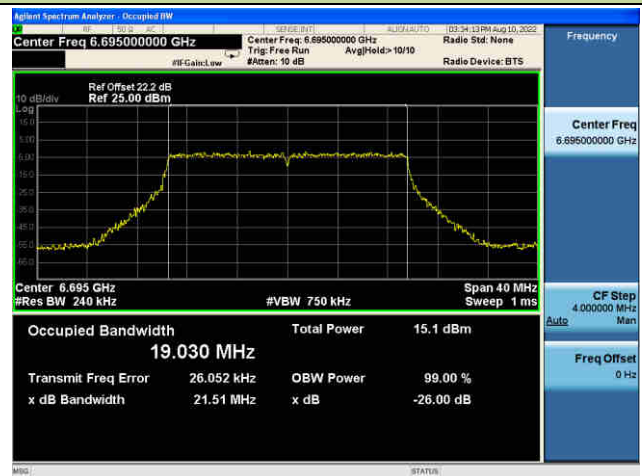

## Channel 181 (6855MHz)

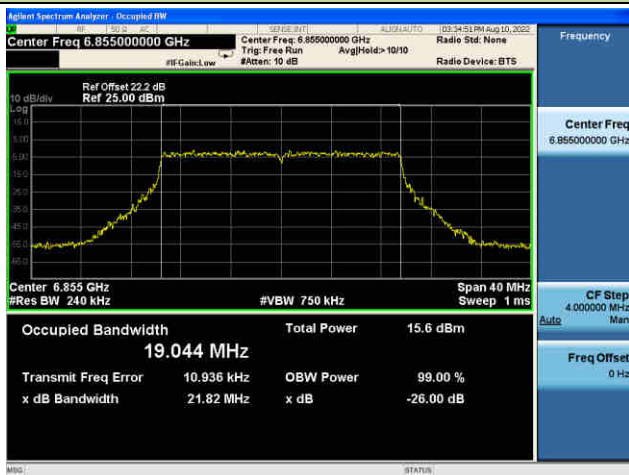

## Channel 185 (6875MHz)

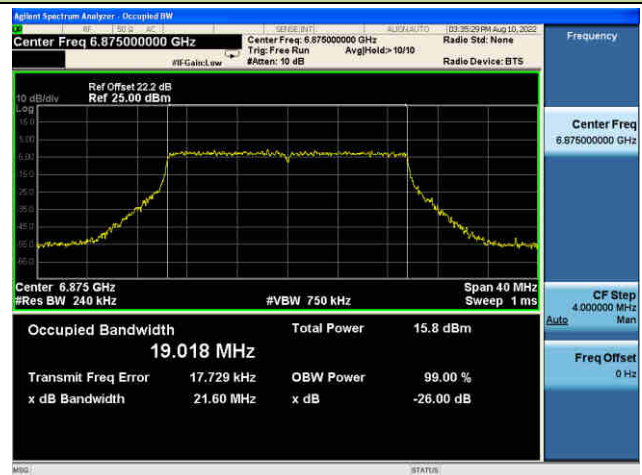

## Channel 189 (6895MHz)

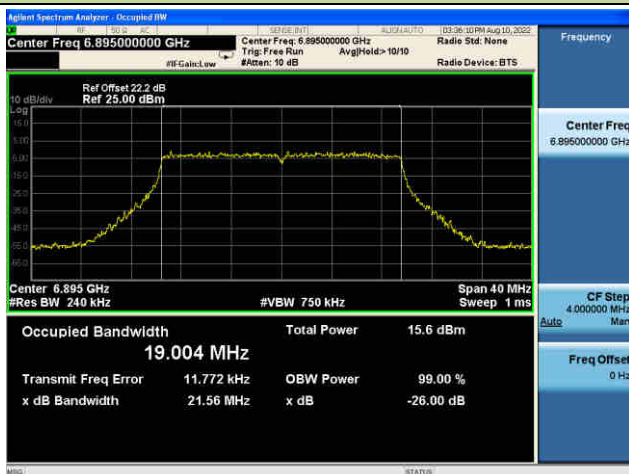

## Channel 209 (6995MHz)

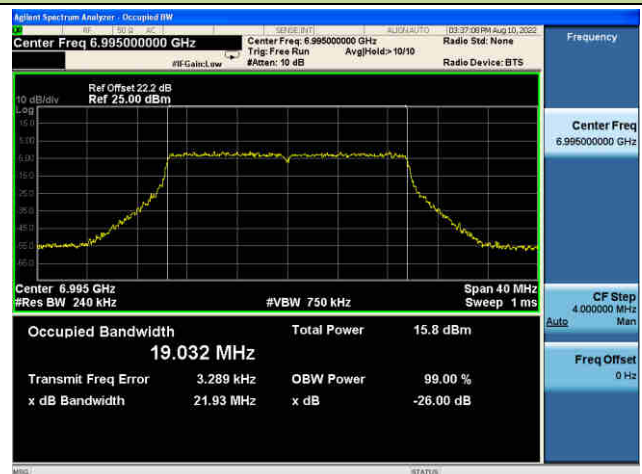



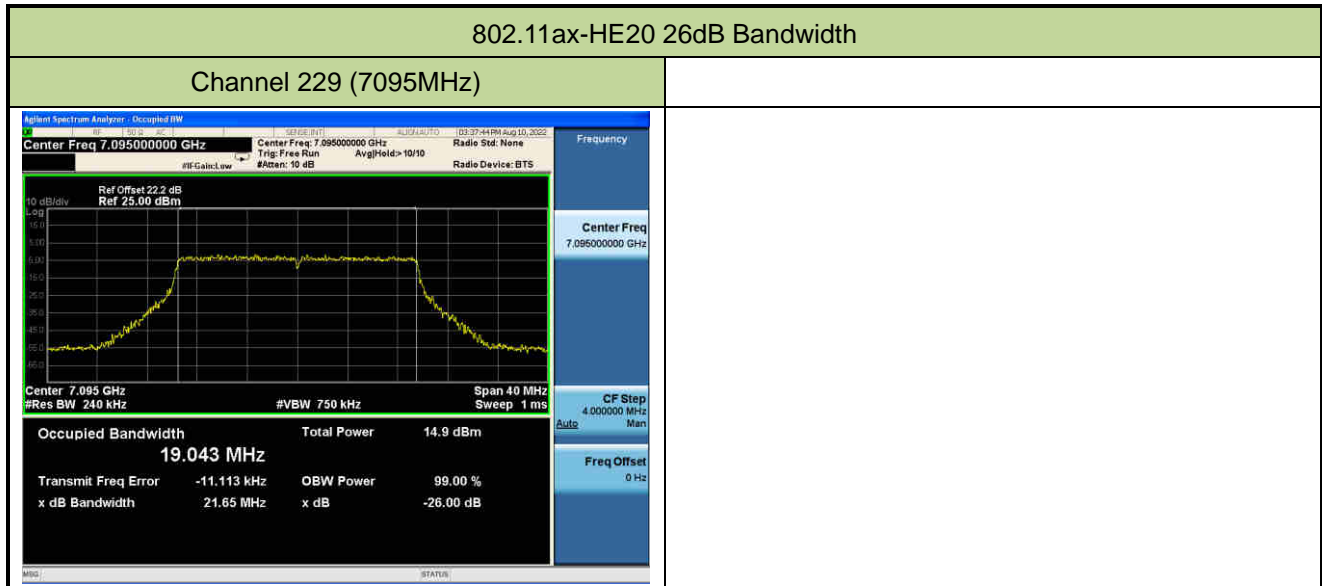

## 802.11ax-HE40 26dB Bandwidth

## Channel 3 (5965MHz)



## Channel 51 (6205MHz)



## Channel 91 (6405MHz)



## Channel 99 (6445MHz)



## Channel 107 (6485MHz)

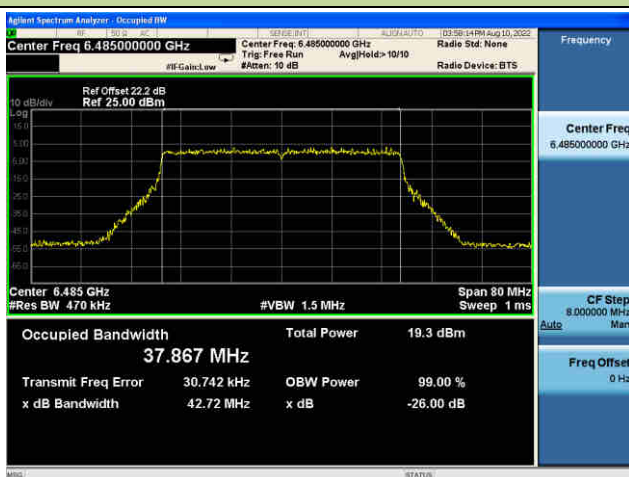

## Channel 115 (6525MHz)

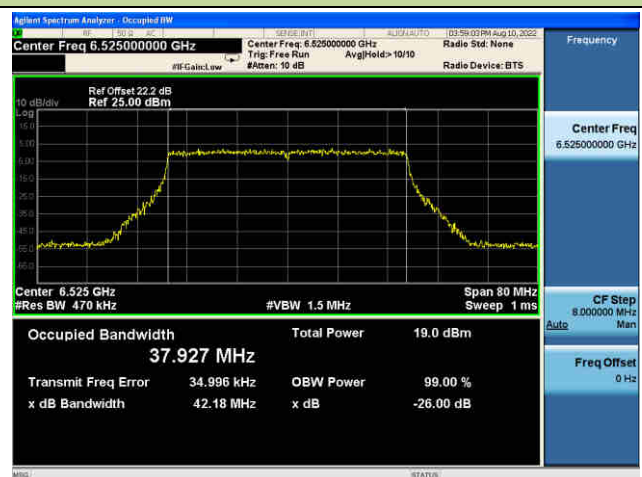

## 802.11ax-HE40 26dB Bandwidth

## Channel 123 (6565MHz)



## Channel 147 (6685MHz)



## Channel 187 (6885MHz)

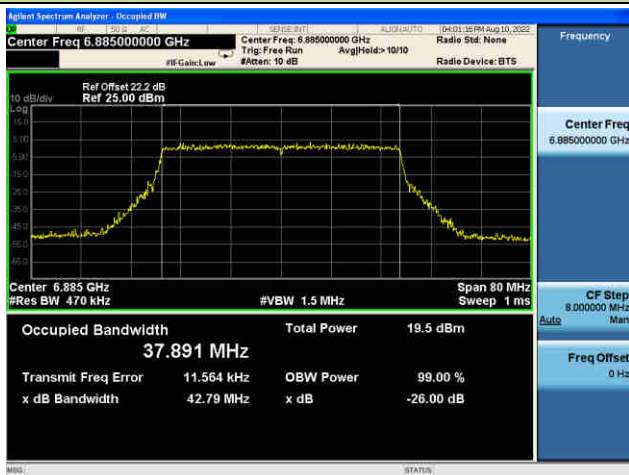

## Channel 195 (6925MHz)



## Channel 211 (7005MHz)

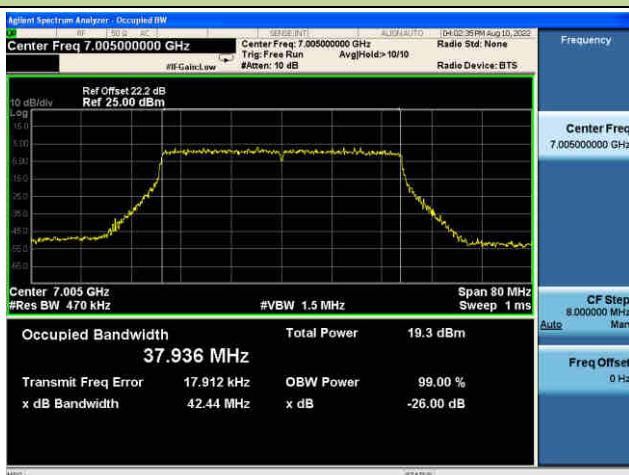

## Channel 227 (7085MHz)

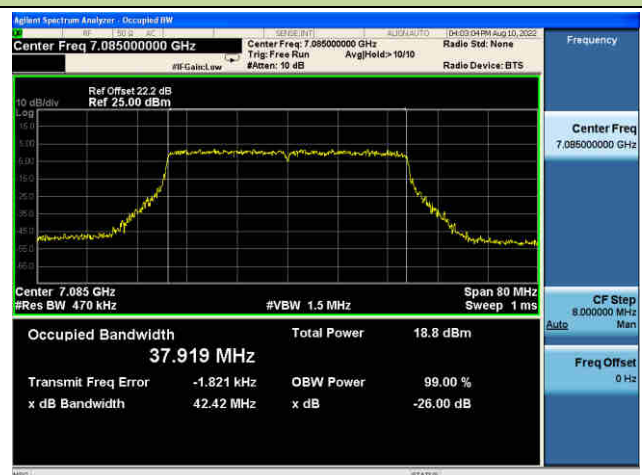

## 802.11ax-HE80 26dB Bandwidth

## Channel 7 (5985MHz)



## Channel 55 (6225MHz)



## Channel 87 (6385MHz)

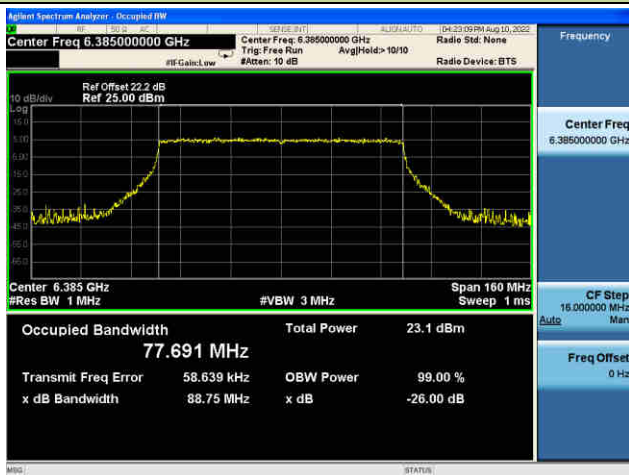

## Channel 103 (6465MHz)



## Channel 119 (6545MHz)

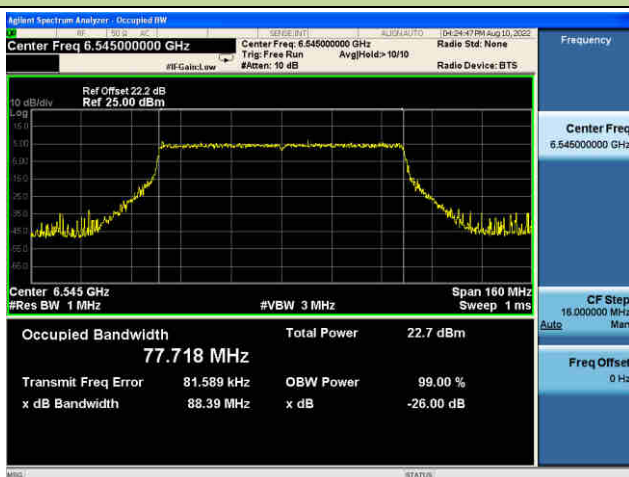

## Channel 135 (6625MHz)

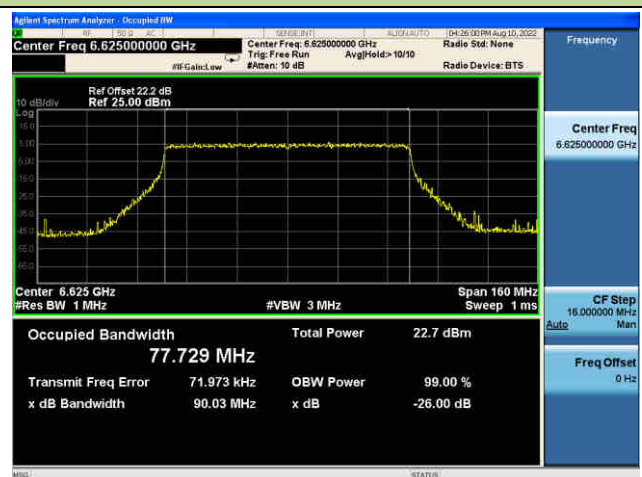

## 802.11ax-HE80 26dB Bandwidth

## Channel 151 (6705MHz)



## Channel 167 (6785MHz)



## Channel 183 (6865MHz)

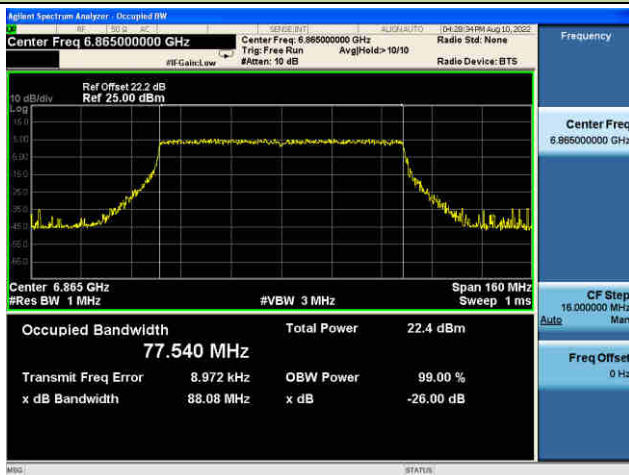

## Channel 199 (6945MHz)



## Channel 215 (7025MHz)





## 802.11ax-HE160 26dB Bandwidth

## Channel 15 (6025MHz)



## Channel 47 (6185MHz)



## Channel 79 (6345MHz)

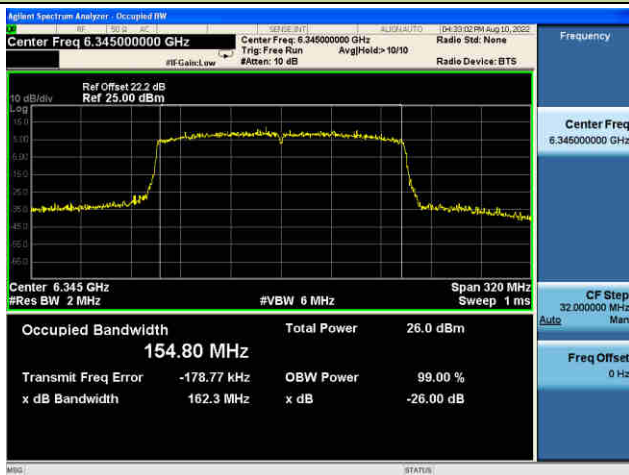

## Channel 111 (6505MHz)

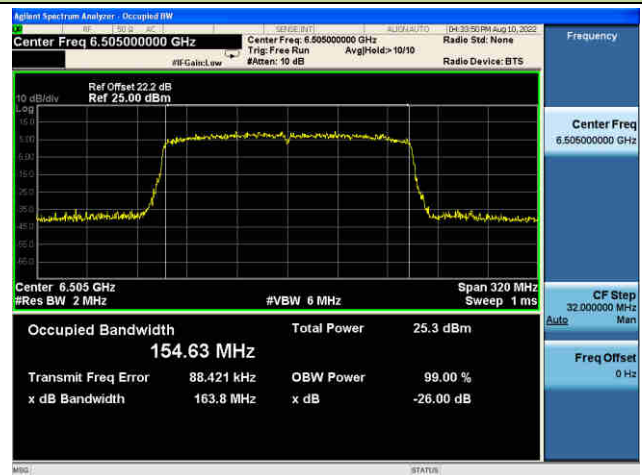

## Channel 143 (6665MHz)

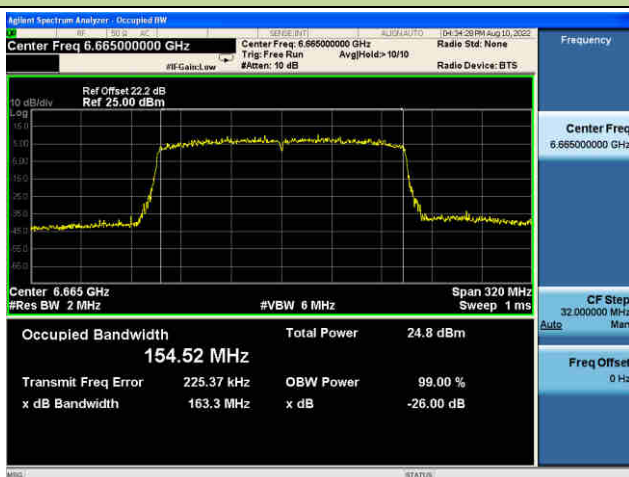

## Channel 175 (6825MHz)

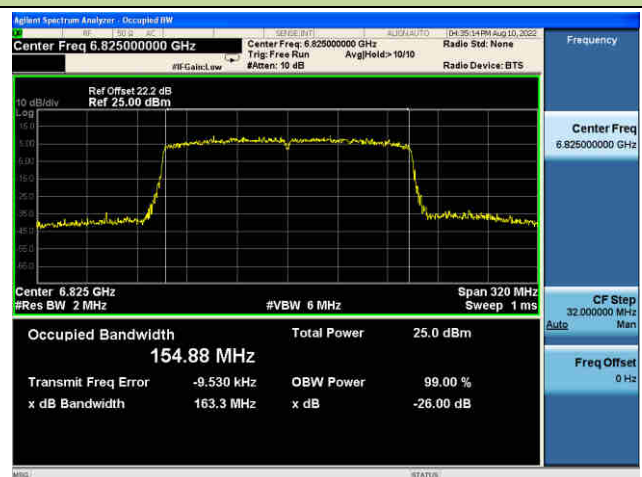

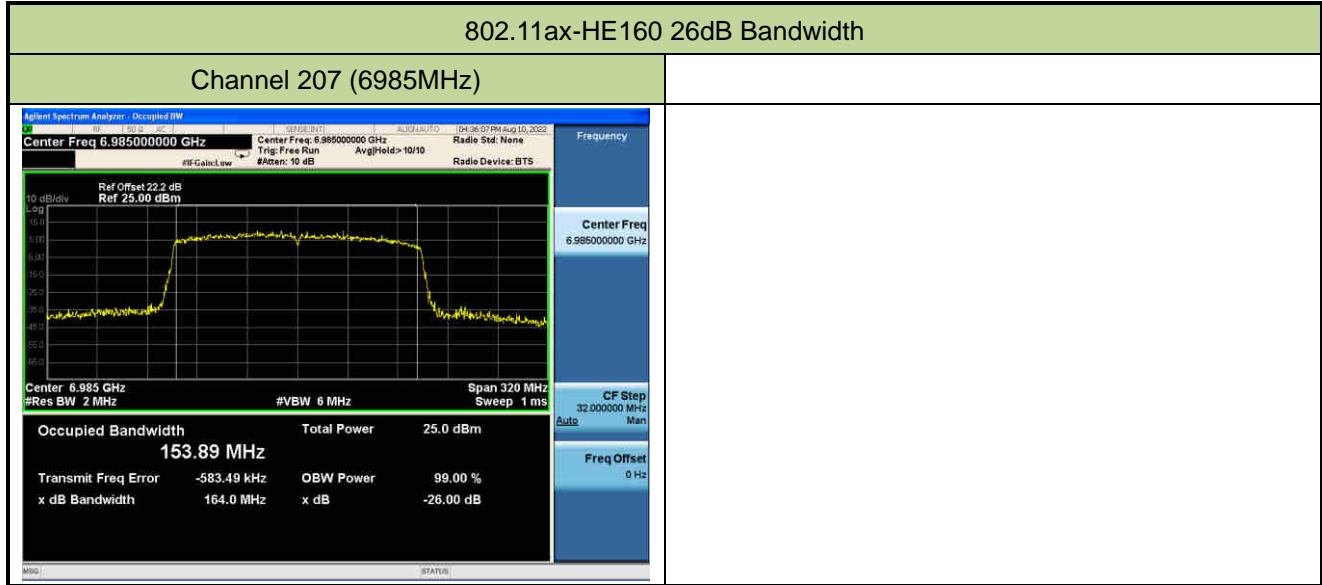

**A.3 Output Power Test Result**

|           |                       |               |             |
|-----------|-----------------------|---------------|-------------|
| Test Site | NS-TR2                | Test Engineer | Summer Tang |
| Test Date | 2022-08-08~2022-08-10 |               |             |

| Test Mode | Data Rate/<br>MCS | Channel No. | Freq. (MHz) | Average Power (dBm) |       |       |       | Total Average Power (dBm) | EIRP (dBm) | EIRP Limit (dBm) |
|-----------|-------------------|-------------|-------------|---------------------|-------|-------|-------|---------------------------|------------|------------------|
|           |                   |             |             | Ant 0               | Ant 1 | Ant 2 | Ant 3 |                           |            |                  |
| 11ax-HE20 | MCS11             | 1           | 5955        | 5.66                | 6.22  | 6.23  | 6.47  | 12.18                     | 15.28      | ≤ 30.00          |
| 11ax-HE20 | MCS11             | 49          | 6195        | 6.56                | 6.71  | 6.85  | 6.68  | 12.72                     | 15.82      | ≤ 30.00          |
| 11ax-HE20 | MCS11             | 93          | 6415        | 6.64                | 7.19  | 7.15  | 7.51  | 13.15                     | 16.25      | ≤ 30.00          |
| 11ax-HE20 | MCS11             | 97          | 6435        | 6.63                | 7.20  | 7.19  | 7.46  | 13.15                     | 16.25      | ≤ 30.00          |
| 11ax-HE20 | MCS11             | 105         | 6475        | 6.58                | 7.06  | 7.13  | 7.45  | 13.09                     | 16.19      | ≤ 30.00          |
| 11ax-HE20 | MCS11             | 113         | 6515        | 7.25                | 7.31  | 7.52  | 7.64  | 13.45                     | 16.55      | ≤ 30.00          |
| 11ax-HE20 | MCS11             | 117         | 6535        | 7.07                | 7.29  | 7.49  | 7.71  | 13.42                     | 16.52      | ≤ 30.00          |
| 11ax-HE20 | MCS11             | 149         | 6695        | 5.98                | 6.34  | 6.72  | 6.73  | 12.47                     | 15.57      | ≤ 30.00          |
| 11ax-HE20 | MCS11             | 181         | 6855        | 6.21                | 6.44  | 6.95  | 7.01  | 12.69                     | 15.79      | ≤ 30.00          |
| 11ax-HE20 | MCS11             | 185         | 6875        | 6.22                | 6.36  | 6.97  | 7.04  | 12.68                     | 15.78      | ≤ 30.00          |
| 11ax-HE20 | MCS11             | 189         | 6895        | 5.78                | 6.32  | 6.78  | 6.83  | 12.47                     | 15.57      | ≤ 30.00          |
| 11ax-HE20 | MCS11             | 209         | 6995        | 5.95                | 6.47  | 6.80  | 6.92  | 12.57                     | 15.67      | ≤ 30.00          |
| 11ax-HE20 | MCS11             | 229         | 7095        | 5.80                | 6.34  | 6.93  | 7.11  | 12.60                     | 15.70      | ≤ 30.00          |
| 11ax-HE40 | MCS11             | 3           | 5965        | 8.96                | 9.61  | 10.03 | 9.91  | 15.67                     | 18.77      | ≤ 30.00          |
| 11ax-HE40 | MCS11             | 51          | 6205        | 9.44                | 9.88  | 10.06 | 9.69  | 15.79                     | 18.89      | ≤ 30.00          |
| 11ax-HE40 | MCS11             | 91          | 6405        | 10.62               | 11.01 | 10.96 | 11.40 | 17.03                     | 20.13      | ≤ 30.00          |
| 11ax-HE40 | MCS11             | 99          | 6445        | 9.88                | 10.53 | 10.89 | 11.05 | 16.63                     | 19.73      | ≤ 30.00          |
| 11ax-HE40 | MCS11             | 107         | 6485        | 10.44               | 10.71 | 11.16 | 11.12 | 16.89                     | 19.99      | ≤ 30.00          |
| 11ax-HE40 | MCS11             | 115         | 6525        | 10.60               | 10.54 | 10.87 | 10.95 | 16.76                     | 19.86      | ≤ 30.00          |
| 11ax-HE40 | MCS11             | 123         | 6565        | 10.53               | 10.83 | 10.95 | 11.25 | 16.92                     | 20.02      | ≤ 30.00          |
| 11ax-HE40 | MCS11             | 147         | 6685        | 9.15                | 10.02 | 10.20 | 10.22 | 15.94                     | 19.04      | ≤ 30.00          |
| 11ax-HE40 | MCS11             | 187         | 6885        | 9.29                | 10.15 | 10.30 | 10.52 | 16.11                     | 19.21      | ≤ 30.00          |
| 11ax-HE40 | MCS11             | 195         | 6925        | 9.37                | 10.19 | 10.29 | 10.48 | 16.12                     | 19.22      | ≤ 30.00          |
| 11ax-HE40 | MCS11             | 211         | 7005        | 9.72                | 9.92  | 10.35 | 10.50 | 16.15                     | 19.25      | ≤ 30.00          |
| 11ax-HE40 | MCS11             | 227         | 7085        | 9.51                | 9.97  | 10.52 | 10.62 | 16.20                     | 19.30      | ≤ 30.00          |



| Test Mode  | Data Rate/MCS | Channel No. | Freq. (MHz) | Average Power (dBm) |       |       |       | Total Average Power (dBm) | EIRP (dBm) | EIRP Limit (dBm) |
|------------|---------------|-------------|-------------|---------------------|-------|-------|-------|---------------------------|------------|------------------|
|            |               |             |             | Ant 0               | Ant 1 | Ant 2 | Ant 3 |                           |            |                  |
| 11ax-HE80  | MCS11         | 7           | 5985        | 12.58               | 13.08 | 13.20 | 13.47 | 19.11                     | 22.21      | ≤ 30.00          |
| 11ax-HE80  | MCS11         | 55          | 6225        | 13.01               | 13.53 | 13.65 | 13.45 | 19.44                     | 22.54      | ≤ 30.00          |
| 11ax-HE80  | MCS11         | 87          | 6385        | 13.30               | 13.47 | 13.74 | 13.91 | 19.63                     | 22.73      | ≤ 30.00          |
| 11ax-HE80  | MCS11         | 103         | 6465        | 13.62               | 13.87 | 14.17 | 14.28 | 20.01                     | 23.11      | ≤ 30.00          |
| 11ax-HE80  | MCS11         | 119         | 6545        | 13.80               | 13.59 | 13.90 | 13.89 | 19.82                     | 22.92      | ≤ 30.00          |
| 11ax-HE80  | MCS11         | 135         | 6625        | 12.53               | 13.19 | 13.40 | 13.32 | 19.14                     | 22.24      | ≤ 30.00          |
| 11ax-HE80  | MCS11         | 151         | 6705        | 12.19               | 12.84 | 13.26 | 13.19 | 18.91                     | 22.01      | ≤ 30.00          |
| 11ax-HE80  | MCS11         | 167         | 6785        | 12.51               | 13.33 | 13.50 | 13.44 | 19.23                     | 22.33      | ≤ 30.00          |
| 11ax-HE80  | MCS11         | 183         | 6865        | 12.39               | 13.07 | 13.25 | 13.31 | 19.04                     | 22.14      | ≤ 30.00          |
| 11ax-HE80  | MCS11         | 199         | 6945        | 12.60               | 13.11 | 13.28 | 13.56 | 19.17                     | 22.27      | ≤ 30.00          |
| 11ax-HE80  | MCS11         | 215         | 7025        | 12.49               | 13.02 | 13.34 | 13.46 | 19.11                     | 22.21      | ≤ 30.00          |
| 11ax-HE160 | MCS0          | 15          | 6025        | 14.61               | 14.84 | 14.95 | 15.21 | 20.93                     | 24.03      | ≤ 30.00          |
| 11ax-HE160 | MCS0          | 47          | 6185        | 15.73               | 16.05 | 15.94 | 15.59 | 21.85                     | 24.95      | ≤ 30.00          |
| 11ax-HE160 | MCS0          | 79          | 6345        | 16.05               | 16.51 | 16.61 | 16.82 | 22.53                     | 25.63      | ≤ 30.00          |
| 11ax-HE160 | MCS0          | 111         | 6505        | 15.80               | 15.84 | 16.33 | 16.14 | 22.05                     | 25.15      | ≤ 30.00          |
| 11ax-HE160 | MCS0          | 143         | 6665        | 14.61               | 15.55 | 15.67 | 15.38 | 21.34                     | 24.44      | ≤ 30.00          |
| 11ax-HE160 | MCS0          | 175         | 6825        | 14.67               | 15.33 | 15.52 | 15.69 | 21.34                     | 24.44      | ≤ 30.00          |
| 11ax-HE160 | MCS0          | 207         | 6985        | 15.02               | 15.27 | 15.87 | 15.75 | 21.51                     | 24.61      | ≤ 30.00          |

Note 1: Total Average Power (dBm) =  $10 \cdot \log \{10^{(\text{Ant 0 Average Power} / 10)} + 10^{(\text{Ant 1 Average Power} / 10)} + 10^{(\text{Ant 2 Average Power} / 10)} + 10^{(\text{Ant 3 Average Power} / 10)}\}$ .

Note 2: EIRP Power (dBm) = Total Average Power (dBm) + Antenna Gain (dBi).

**A.4 Power Spectral Density Test Result**

|           |                       |               |             |
|-----------|-----------------------|---------------|-------------|
| Test Site | NS-TR2                | Test Engineer | Summer Tang |
| Test Date | 2022-08-08~2022-08-10 |               |             |

| Test Mode     | Data Rate/MCS | Channel No. | Freq. (MHz) | PSD (dBm/MHz) |        |        |        | Duty Cycle (%) | EIRP PSD (dBm/MHz) | EIRP PSD Limit (dBm/MHz) |
|---------------|---------------|-------------|-------------|---------------|--------|--------|--------|----------------|--------------------|--------------------------|
|               |               |             |             | Ant 0         | Ant 1  | Ant 2  | Ant 3  |                |                    |                          |
| 802.11ax-HE20 | MCS11         | 1           | 5955        | -5.521        | -5.226 | -5.175 | -4.939 | 85.55          | 4.59               | ≤ 5.00                   |
| 802.11ax-HE20 | MCS11         | 49          | 6195        | -5.046        | -5.063 | -4.950 | -5.184 | 85.55          | 4.74               | ≤ 5.00                   |
| 802.11ax-HE20 | MCS11         | 93          | 6415        | -5.535        | -5.163 | -5.150 | -4.914 | 85.55          | 4.61               | ≤ 5.00                   |
| 802.11ax-HE20 | MCS11         | 97          | 6435        | -5.694        | -5.184 | -5.230 | -4.947 | 85.55          | 4.54               | ≤ 5.00                   |
| 802.11ax-HE20 | MCS11         | 105         | 6475        | -5.790        | -5.272 | -5.269 | -5.074 | 85.55          | 4.46               | ≤ 5.00                   |
| 802.11ax-HE20 | MCS11         | 113         | 6515        | -5.111        | -5.090 | -4.888 | -4.810 | 85.55          | 4.83               | ≤ 5.00                   |
| 802.11ax-HE20 | MCS11         | 117         | 6535        | -5.157        | -5.042 | -4.801 | -4.785 | 85.55          | 4.86               | ≤ 5.00                   |
| 802.11ax-HE20 | MCS11         | 149         | 6695        | -5.492        | -5.116 | -4.898 | -4.928 | 85.55          | 4.70               | ≤ 5.00                   |
| 802.11ax-HE20 | MCS11         | 181         | 6855        | -5.385        | -5.250 | -4.664 | -4.668 | 85.55          | 4.82               | ≤ 5.00                   |
| 802.11ax-HE20 | MCS11         | 185         | 6875        | -5.444        | -5.219 | -4.645 | -4.705 | 85.55          | 4.81               | ≤ 5.00                   |
| 802.11ax-HE20 | MCS11         | 189         | 6895        | -5.846        | -5.357 | -4.720 | -4.747 | 85.55          | 4.66               | ≤ 5.00                   |
| 802.11ax-HE20 | MCS11         | 209         | 6995        | -5.589        | -5.188 | -4.795 | -4.744 | 85.55          | 4.73               | ≤ 5.00                   |
| 802.11ax-HE20 | MCS11         | 229         | 7095        | -6.157        | -5.682 | -5.129 | -4.840 | 85.55          | 4.38               | ≤ 5.00                   |
| 802.11ax-HE40 | MCS11         | 3           | 5965        | -5.461        | -4.706 | -4.564 | -4.511 | 93.77          | 4.61               | ≤ 5.00                   |
| 802.11ax-HE40 | MCS11         | 51          | 6205        | -5.259        | -4.915 | -4.760 | -5.068 | 93.77          | 4.40               | ≤ 5.00                   |
| 802.11ax-HE40 | MCS11         | 91          | 6405        | -5.157        | -4.432 | -4.602 | -4.088 | 93.77          | 4.85               | ≤ 5.00                   |
| 802.11ax-HE40 | MCS11         | 99          | 6445        | -5.563        | -4.978 | -4.795 | -4.474 | 93.77          | 4.47               | ≤ 5.00                   |
| 802.11ax-HE40 | MCS11         | 107         | 6485        | -5.076        | -4.904 | -4.442 | -4.481 | 93.77          | 4.68               | ≤ 5.00                   |
| 802.11ax-HE40 | MCS11         | 115         | 6525        | -5.224        | -4.939 | -4.602 | -4.584 | 93.77          | 4.57               | ≤ 5.00                   |
| 802.11ax-HE40 | MCS11         | 123         | 6565        | -5.110        | -4.508 | -4.279 | -4.199 | 93.77          | 4.89               | ≤ 5.00                   |
| 802.11ax-HE40 | MCS11         | 147         | 6685        | -5.536        | -4.774 | -4.499 | -4.547 | 93.77          | 4.58               | ≤ 5.00                   |
| 802.11ax-HE40 | MCS11         | 187         | 6885        | -5.647        | -4.698 | -4.625 | -4.309 | 93.77          | 4.61               | ≤ 5.00                   |
| 802.11ax-HE40 | MCS11         | 195         | 6925        | -5.308        | -4.530 | -4.437 | -4.194 | 93.77          | 4.80               | ≤ 5.00                   |
| 802.11ax-HE40 | MCS11         | 211         | 7005        | -5.118        | -4.810 | -4.516 | -4.211 | 93.77          | 4.75               | ≤ 5.00                   |
| 802.11ax-HE40 | MCS11         | 227         | 7085        | -5.597        | -5.041 | -4.605 | -4.468 | 93.77          | 4.49               | ≤ 5.00                   |

| Test Mode      | Data Rate/<br>MCS | Channel No. | Freq. (MHz) | PSD (dBm/MHz) |        |        |        | Duty Cycle (%) | EIRP PSD (dBm/MHz) | EIRP PSD Limit (dBm/MHz) |
|----------------|-------------------|-------------|-------------|---------------|--------|--------|--------|----------------|--------------------|--------------------------|
|                |                   |             |             | Ant 0         | Ant 1  | Ant 2  | Ant 3  |                |                    |                          |
| 802.11ax-HE80  | MCS11             | 7           | 5985        | -5.067        | -4.707 | -4.581 | -4.313 | 92.56          | 4.80               | ≤ 5.00                   |
| 802.11ax-HE80  | MCS11             | 55          | 6225        | -5.145        | -4.506 | -4.574 | -4.763 | 92.56          | 4.72               | ≤ 5.00                   |
| 802.11ax-HE80  | MCS11             | 87          | 6385        | -5.222        | -5.035 | -4.826 | -4.614 | 92.56          | 4.54               | ≤ 5.00                   |
| 802.11ax-HE80  | MCS11             | 103         | 6465        | -5.004        | -4.748 | -4.487 | -4.354 | 92.56          | 4.82               | ≤ 5.00                   |
| 802.11ax-HE80  | MCS11             | 119         | 6545        | -4.715        | -4.903 | -4.590 | -4.549 | 92.56          | 4.77               | ≤ 5.00                   |
| 802.11ax-HE80  | MCS11             | 135         | 6625        | -5.622        | -4.912 | -4.754 | -4.950 | 92.56          | 4.41               | ≤ 5.00                   |
| 802.11ax-HE80  | MCS11             | 151         | 6705        | -5.603        | -4.733 | -4.482 | -4.471 | 92.56          | 4.66               | ≤ 5.00                   |
| 802.11ax-HE80  | MCS11             | 167         | 6785        | -5.175        | -4.403 | -4.287 | -4.503 | 92.56          | 4.88               | ≤ 5.00                   |
| 802.11ax-HE80  | MCS11             | 183         | 6865        | -5.542        | -4.884 | -4.723 | -4.759 | 92.56          | 4.49               | ≤ 5.00                   |
| 802.11ax-HE80  | MCS11             | 199         | 6945        | -5.119        | -4.641 | -4.553 | -4.228 | 92.56          | 4.83               | ≤ 5.00                   |
| 802.11ax-HE80  | MCS11             | 215         | 7025        | -5.173        | -4.633 | -4.333 | -4.248 | 92.56          | 4.87               | ≤ 5.00                   |
| 802.11ax-HE160 | MCS0              | 15          | 6025        | -5.275        | -4.734 | -4.724 | -4.371 | 93.32          | 4.66               | ≤ 5.00                   |
| 802.11ax-HE160 | MCS0              | 47          | 6185        | -5.080        | -4.603 | -4.369 | -4.672 | 93.32          | 4.75               | ≤ 5.00                   |
| 802.11ax-HE160 | MCS0              | 79          | 6345        | -5.055        | -4.445 | -4.449 | -4.211 | 93.32          | 4.89               | ≤ 5.00                   |
| 802.11ax-HE160 | MCS0              | 111         | 6505        | -5.048        | -4.977 | -4.399 | -4.584 | 93.32          | 4.68               | ≤ 5.00                   |
| 802.11ax-HE160 | MCS0              | 143         | 6665        | -5.389        | -4.533 | -4.363 | -4.481 | 93.32          | 4.75               | ≤ 5.00                   |
| 802.11ax-HE160 | MCS0              | 175         | 6825        | -5.572        | -4.680 | -4.538 | -4.398 | 93.32          | 4.65               | ≤ 5.00                   |
| 802.11ax-HE160 | MCS0              | 207         | 6985        | -5.409        | -5.123 | -4.784 | -4.629 | 93.32          | 4.45               | ≤ 5.00                   |

Note: When EUT duty cycle < 98%, EIRP PSD (dBm/MHz) =  $10 \cdot \log \{10^{(\text{Ant 0 PSD}/10)} + 10^{(\text{Ant 1 PSD}/10)} + 10^{(\text{Ant 2 PSD}/10)} + 10^{(\text{Ant 3 PSD}/10)}\}$  (dBm/MHz) +  $10 \cdot \log (1/\text{Duty Cycle})$  + Antenna Gain (dBi).

## 802.11ax-HE20 Power Spectral Density - Ant 0

Channel 1 (5955MHz)



Channel 49 (6195MHz)



Channel 93 (6415MHz)



Channel 97 (6435MHz)



Channel 105 (6475MHz)



Channel 113 (6515MHz)

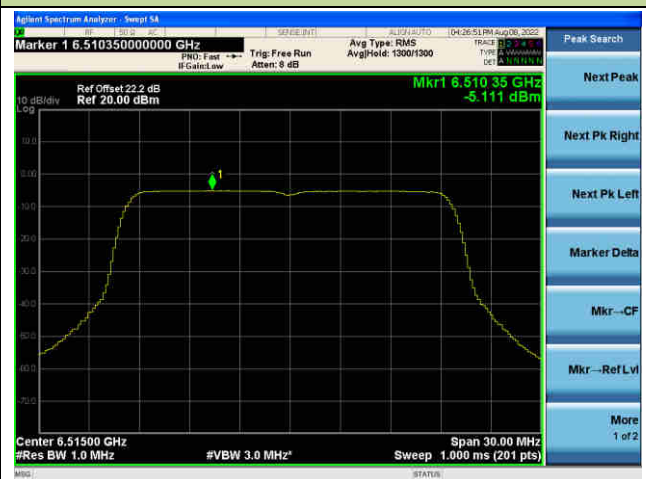

## 802.11ax-HE20 Power Spectral Density - Ant 0

Channel 117 (6535MHz)



Channel 149 (6695MHz)



Channel 181 (6855MHz)



Channel 185 (6875MHz)



Channel 189 (6895MHz)

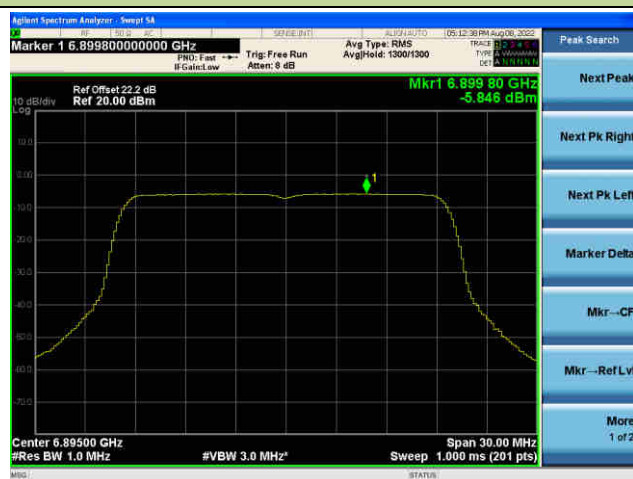

Channel 209 (6995MHz)



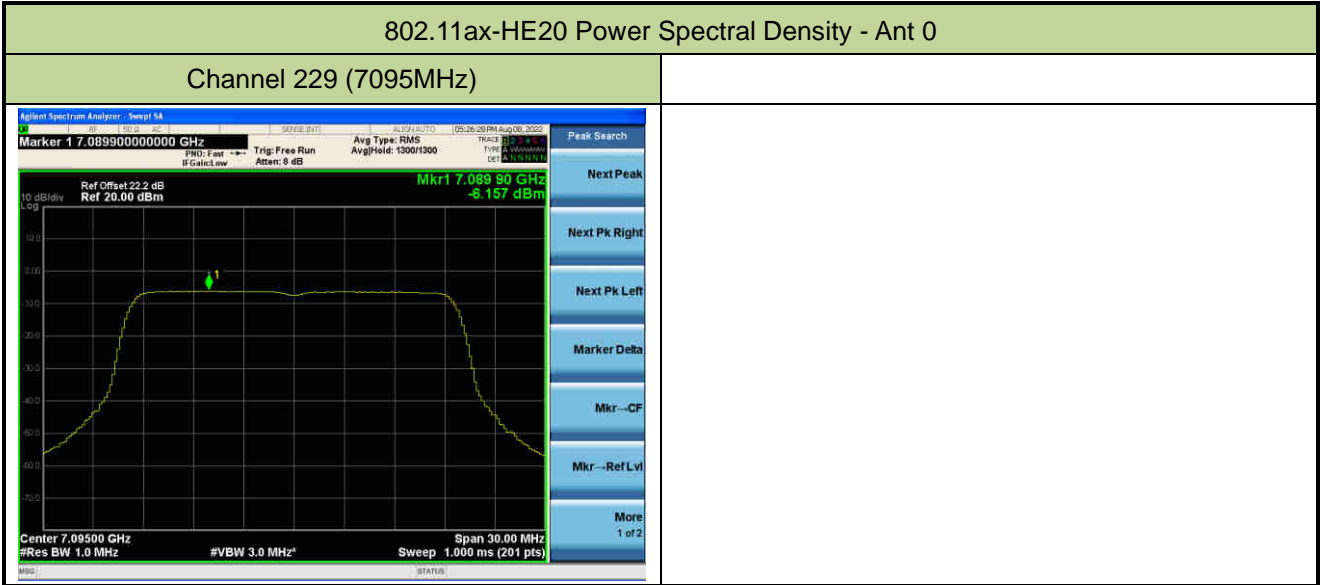

## 802.11ax-HE40 Power Spectral Density - Ant 0

Channel 3 (5965MHz)



Channel 51 (6205MHz)

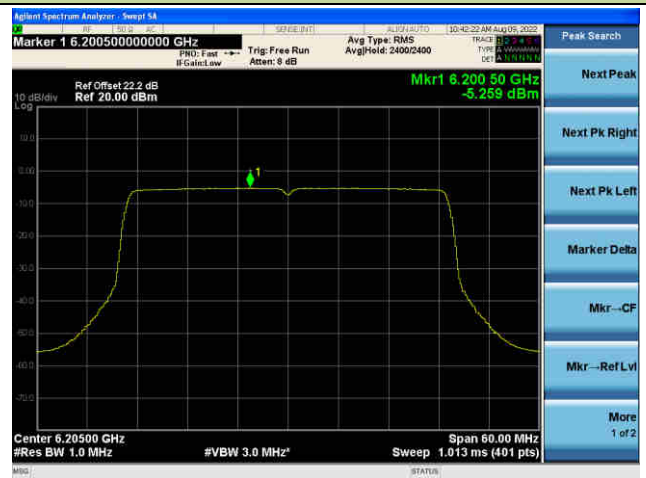

Channel 91 (6405MHz)

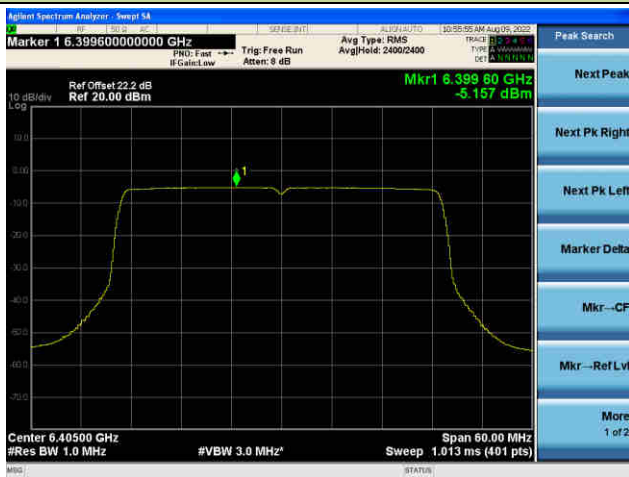

Channel 99 (6445MHz)



Channel 107 (6485MHz)



Channel 115 (6525MHz)

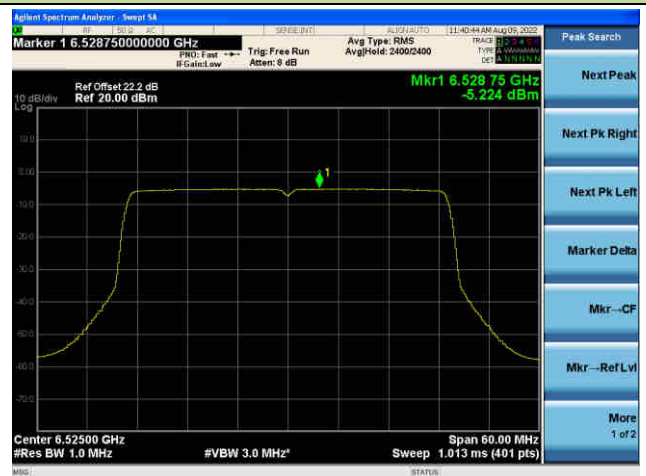



## 802.11ax-HE40 Power Spectral Density - Ant 0

Channel 123 (6565MHz)

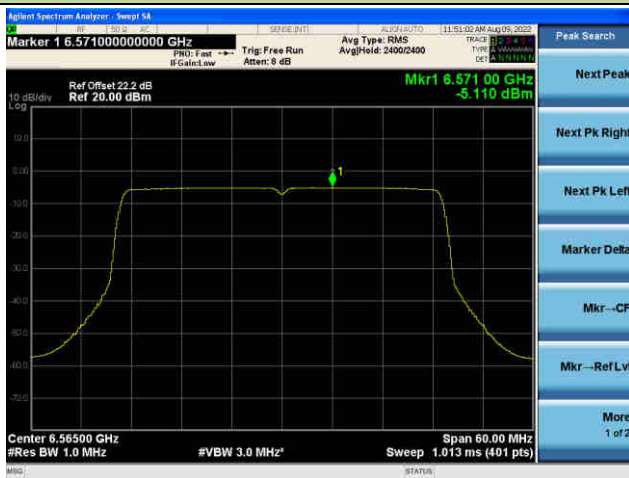

Channel 147 (6685MHz)

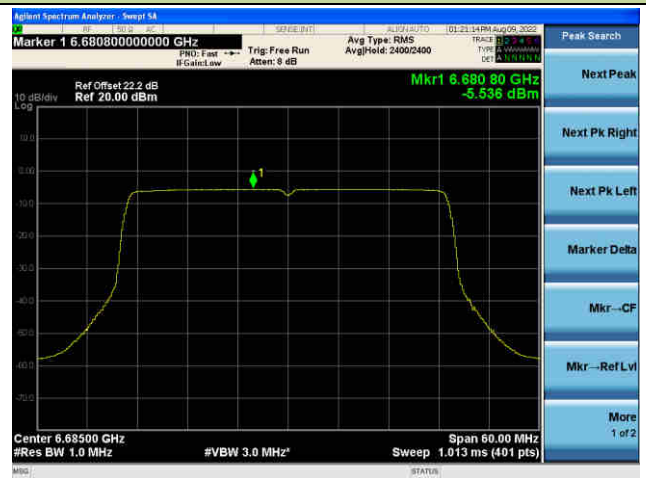

Channel 187 (6885MHz)



Channel 195 (6925MHz)

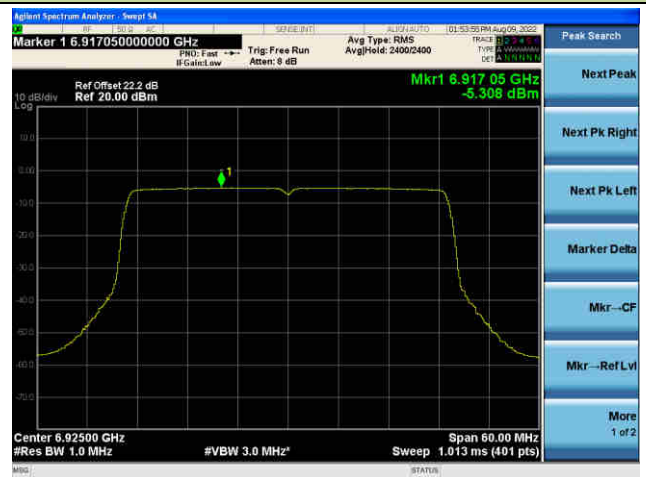

Channel 211 (7005MHz)



Channel 227 (7085MHz)





## 802.11ax-HE80 Power Spectral Density - Ant 0

Channel 7 (5985MHz)



Channel 55 (6225MHz)



Channel 87 (6385MHz)



Channel 103 (6465MHz)



Channel 119 (6545MHz)

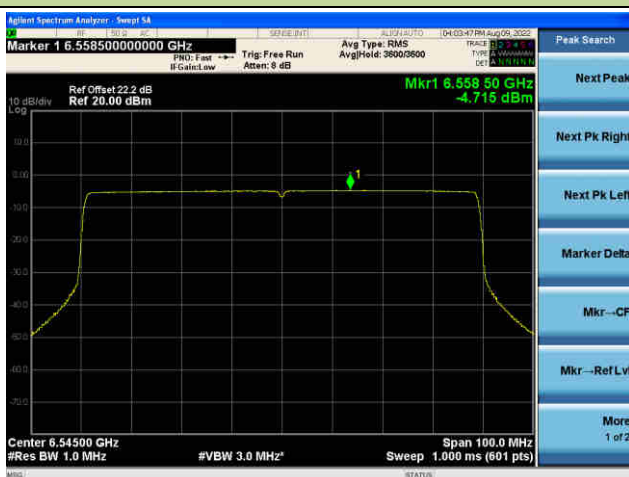

Channel 135 (6625MHz)

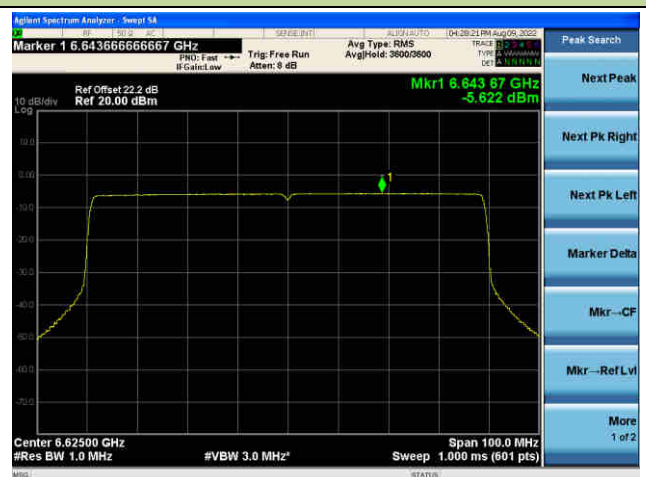

## 802.11ax-HE80 Power Spectral Density - Ant 0

Channel 151 (6705MHz)



Channel 167 (6785MHz)



Channel 183 (6865MHz)



Channel 199 (6945MHz)



Channel 215 (7025MHz)



## 802.11ax-HE160 Power Spectral Density - Ant 0

Channel 15 (6025MHz)



Channel 47 (6185MHz)



Channel 79 (6345MHz)



Channel 111 (6505MHz)



Channel 143 (6665MHz)



Channel 175 (6825MHz)



802.11ax-HE160 Power Spectral Density - Ant 0

Channel 207 (6985MHz)



## 802.11ax-HE20 Power Spectral Density - Ant 1

Channel 1 (5955MHz)



Channel 49 (6195MHz)

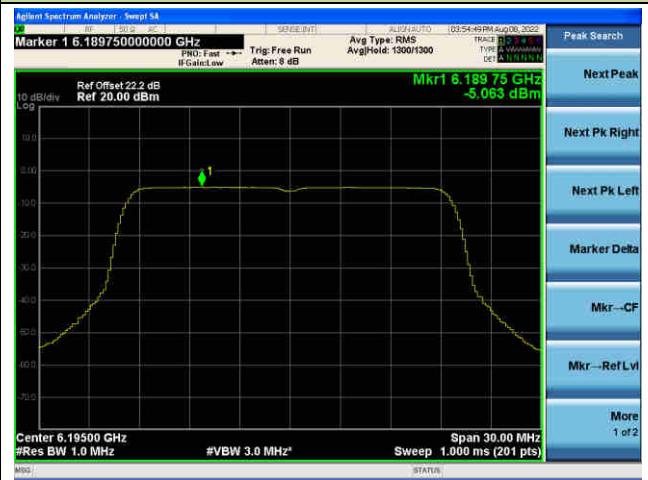

Channel 93 (6415MHz)



Channel 97 (6435MHz)



Channel 105 (6475MHz)



Channel 113 (6515MHz)



## 802.11ax-HE20 Power Spectral Density - Ant 1

Channel 117 (6535MHz)



Channel 149 (6695MHz)



Channel 181 (6855MHz)



Channel 185 (6875MHz)



Channel 189 (6895MHz)



Channel 209 (6995MHz)



802.11ax-HE20 Power Spectral Density - Ant 1

Channel 229 (7095MHz)

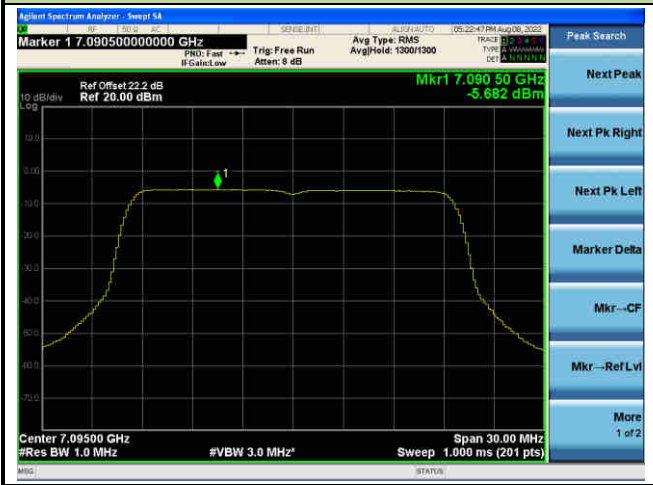



## 802.11ax-HE40 Power Spectral Density - Ant 1

Channel 3 (5965MHz)



Channel 51 (6205MHz)



Channel 91 (6405MHz)



Channel 99 (6445MHz)

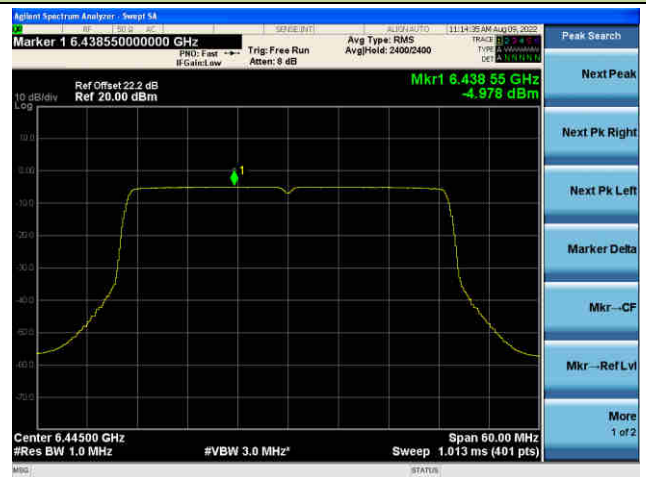

Channel 107 (6485MHz)

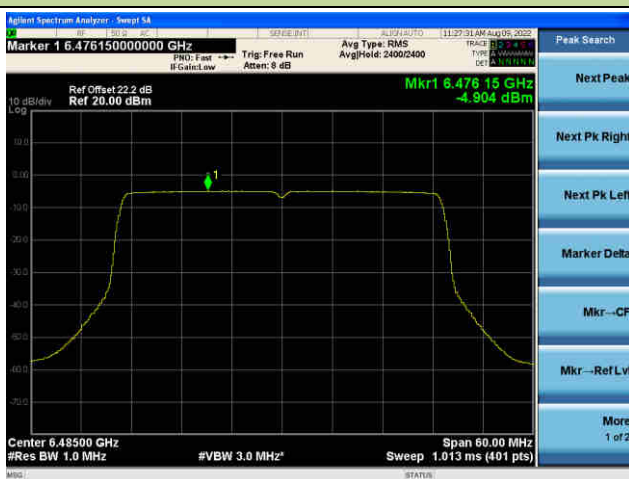

Channel 115 (6525MHz)

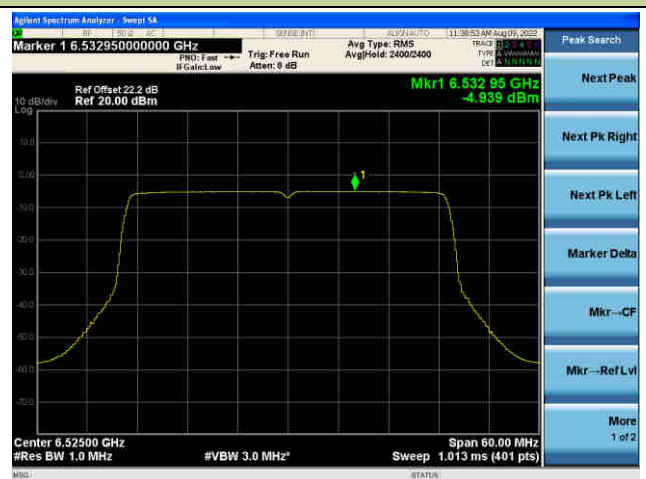



## 802.11ax-HE40 Power Spectral Density - Ant 1

Channel 123 (6565MHz)



Channel 147 (6685MHz)



Channel 187 (6885MHz)

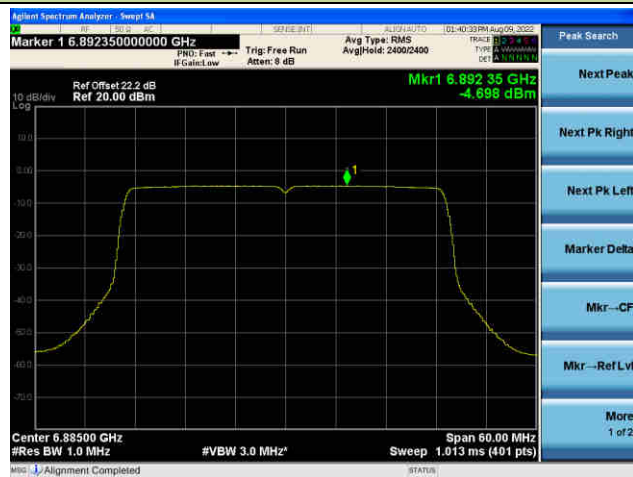

Channel 195 (6925MHz)

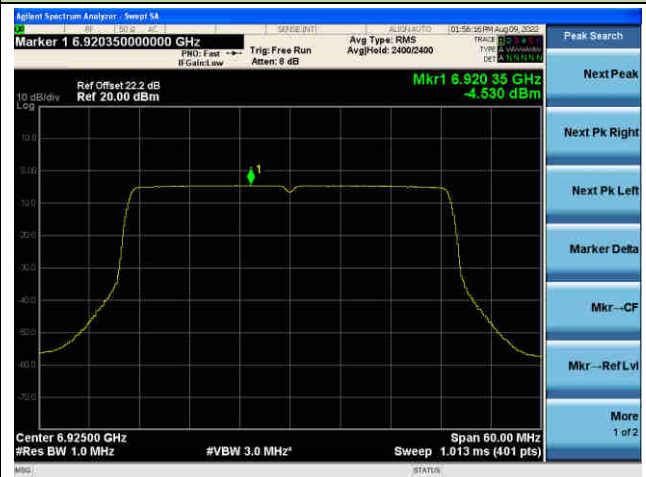

Channel 211 (7005MHz)

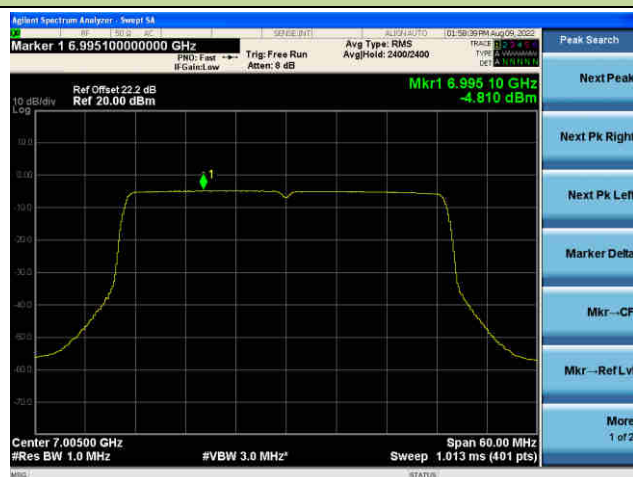

Channel 227 (7085MHz)



## 802.11ax-HE80 Power Spectral Density - Ant 1

Channel 7 (5985MHz)



Channel 55 (6225MHz)



Channel 87 (6385MHz)



Channel 103 (6465MHz)



Channel 119 (6545MHz)

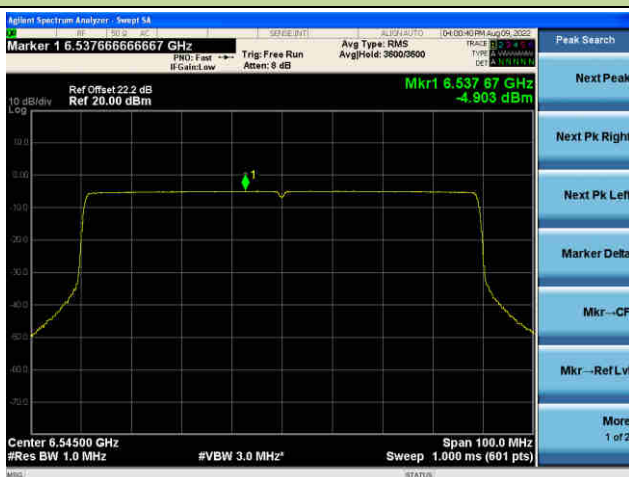

Channel 135 (6625MHz)



## 802.11ax-HE80 Power Spectral Density - Ant 1

Channel 151 (6705MHz)



Channel 167 (6785MHz)



Channel 183 (6865MHz)



Channel 199 (6945MHz)



Channel 215 (7025MHz)



## 802.11ax-HE160 Power Spectral Density - Ant 1

Channel 15 (6025MHz)

Channel 47 (6185MHz)



Channel 79 (6345MHz)

Channel 111 (6505MHz)



Channel 143 (6665MHz)

Channel 175 (6825MHz)



802.11ax-HE160 Power Spectral Density - Ant 1

Channel 207 (6985MHz)



## 802.11ax-HE20 Power Spectral Density - Ant 2

Channel 1 (5955MHz)



Channel 49 (6195MHz)



Channel 93 (6415MHz)



Channel 97 (6435MHz)



Channel 105 (6475MHz)

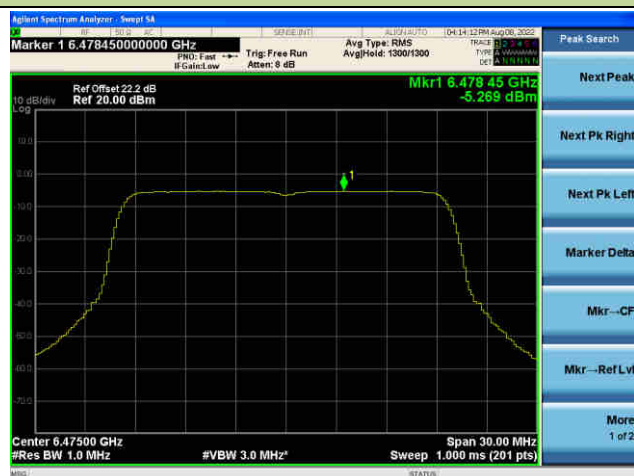

Channel 113 (6515MHz)





## 802.11ax-HE20 Power Spectral Density - Ant 2

Channel 117 (6535MHz)



Channel 149 (6695MHz)



Channel 181 (6855MHz)



Channel 185 (6875MHz)



Channel 189 (6895MHz)

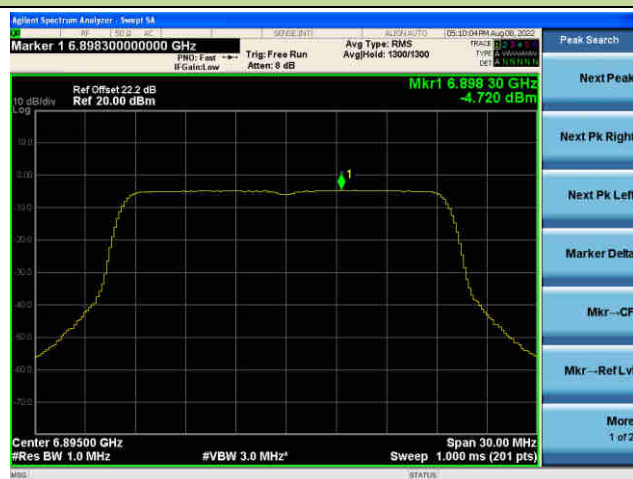

Channel 209 (6995MHz)

