

MEASUREMENT REPORT

FCC PART 15.247 Bluetooth-LE

FCC ID: SFK-WF808
Applicant: CIG Shanghai Co., Ltd.
Application Type: Certification
Product: WiFi 6 Extender
Model No.: WF-808
Brand Name: CIG
FCC Classification: Digital Transmission System (DTS)
FCC Rule Part(s): Part 15 Subpart C (Section 15.247)
Test Procedure(s): ANSI C63.10-2013
Test Date: June 20 ~ July 29, 2021

Reviewed By:

Sunny Sun

Approved By:

Robin Wu



The test results relate only to the samples tested.

This equipment has been shown to be capable of compliance with the applicable technical standards as indicated in the measurement report and was tested in accordance with the measurement procedures specified in ANSI C63.10-2013. Test results reported herein relate only to the item(s) tested.

The test report shall not be reproduced except in full without the written approval of MRT Technology (Suzhou) Co., Ltd.

Revision History

Report No.	Version	Description	Issue Date	Note
2105RSU006-U5	Rev. 01	Initial Report	09-30-2021	Valid

CONTENTS

Description	Page
1. General Information	5
1.1. Applicant	5
1.2. Manufacturer	5
1.3. Testing Facility	5
1.4. Product Information	6
1.5. Radio Specification under Test	6
1.6. Working Frequencies for this report	7
1.7. Description of Available Antennas	7
1.8. Test Mode	7
1.9. Configuration of Test System	8
1.10. Test System Details	8
1.11. Test Software	8
1.12. Test Environment Condition	8
1.13. Duty Cycle	9
1.14. EMI Suppression Device(s)/Modifications	9
2. ANTENNA REQUIREMENTS	10
3. TEST EQUIPMENT CALIBRATION DATE	11
4. MEASUREMENT UNCERTAINTY	14
5. TEST RESULT	15
5.1. Summary	15
5.2. Occupied Bandwidth Measurement	16
5.2.1. Test Limit	16
5.2.2. Test Procedure used	16
5.2.3. Test Setting	16
5.2.4. Test Setup	16
5.2.5. Test Result	17
5.3. Output Power Measurement	18
5.3.1. Test Limit	18
5.3.2. Test Procedure Used	18
5.3.3. Test Setting	18
5.3.4. Test Setup	19
5.3.5. Test Result	20
5.4. Power Spectral Density Measurement	21
5.4.1. Test Limit	21
5.4.2. Test Procedure Used	21

5.4.3.	Test Setting.....	21
5.4.4.	Test Setup	21
5.4.5.	Test Result.....	22
5.5.	Conducted Band Edge and Out-of-Band Emissions	23
5.5.1.	Test Limit	23
5.5.2.	Test Procedure Used	23
5.5.3.	Test Setting.....	23
5.5.4.	Test Setup	24
5.5.5.	Test Result.....	25
5.6.	Radiated Spurious Emission Measurement	27
5.6.1.	Test Limit	27
5.6.2.	Test Procedure Used	27
5.6.3.	Test Setting.....	27
5.6.4.	Test Setup	29
5.6.5.	Test Result.....	30
5.7.	Radiated Restricted Band Edge Measurement.....	35
5.7.1.	Test Limit	35
5.7.2.	Test Procedure Used	36
5.7.3.	Test Setting.....	36
5.7.4.	Test Setup	37
5.7.5.	Test Result.....	38
5.8.	AC Conducted Emissions Measurement	46
5.8.1.	Test Limit	46
5.8.2.	Test Setup	46
5.8.3.	Test Result.....	47
6.	CONCLUSION	49
	Appendix A - Test Setup Photograph	50
	Appendix B - EUT Photograph.....	51

1.4. Product Information

Product Name	WiFi 6 Extender
Model No.	WF-808
Brand Name	CIG
Operating Temperature	0 ~ 40°C
Wi-Fi Specification	802.11a/b/g/n/ac
Bluetooth Specification	v4.0 single mode
Antenna Information	Refer to section 1.7
Power Type	AC/DC Adapter
Accessory	
AC to DC Adapter	Model: ADS0248T-W050250 Input: 100-240V ~ 50-60Hz 0.6A Output: 5V, 2.5A
Remark: 1. The information of EUT was provided by the manufacturer, and the accuracy of the information shall be the responsibility of the manufacturer.	

1.5. Radio Specification under Test

Frequency Range	2402~2480MHz
Channel Number	40
Type of Modulation	GFSK
Data Rate	1Mbps

1.6. Working Frequencies for this report

Channel	Frequency	Channel	Frequency	Channel	Frequency
00	2402 MHz	01	2404 MHz	02	2406 MHz
03	2408 MHz	04	2410 MHz	05	2412 MHz
06	2414 MHz	07	2416 MHz	08	2418 MHz
09	2420 MHz	10	2422 MHz	11	2424 MHz
12	2426 MHz	13	2428 MHz	14	2430 MHz
15	2432 MHz	16	2434 MHz	17	2436 MHz
18	2438 MHz	19	2440 MHz	20	2442 MHz
21	2444 MHz	22	2446 MHz	23	2448 MHz
24	2450 MHz	25	2452 MHz	26	2454 MHz
27	2456 MHz	28	2458 MHz	29	2460 MHz
30	2462 MHz	31	2464 MHz	32	2466 MHz
33	2468 MHz	34	2470 MHz	35	2472 MHz
36	2474 MHz	37	2476 MHz	38	2478 MHz
39	2480 MHz	--	--	--	--

1.7. Description of Available Antennas

Antenna Type	Frequency (MHz)	TX Path	Max Antenna Gain (dBi)	Uncorrelated Antenna Gain (dBi)
Wi-Fi Antenna				
PCB Antenna	2400 ~ 2483.5	2	3.0	0.51
PCB Antenna	5150 ~ 5350	4	6.5	1.95
PCB Antenna	5470 ~ 5725	4	7.2	1.97
Bluetooth Antenna				
PCB Antenna	2400 ~ 2483.5	1	1.9	--
Remark				
1. The device supports SISO Mode for 802.11a and support MIMO mode for 802.11b/g/n/ac and supports the STBC mode only.				
2. Due to the same modulation & power setting between 802.11n and 802.11ac, so 802.11n-HT20 and HT40 are covered by 802.11ac-VHT20 and VHT40 in this report.				

1.8. Test Mode

Test Mode	Mode 1: Transmit by BLE-1Mbps
-----------	-------------------------------

1.9. Configuration of Test System

The measurement procedures and appropriate EUT setup described in the American National Standard of Procedures for Compliance Testing of Unlicensed Wireless Devices (ANSI C63.10-2013) was used in the measurement.

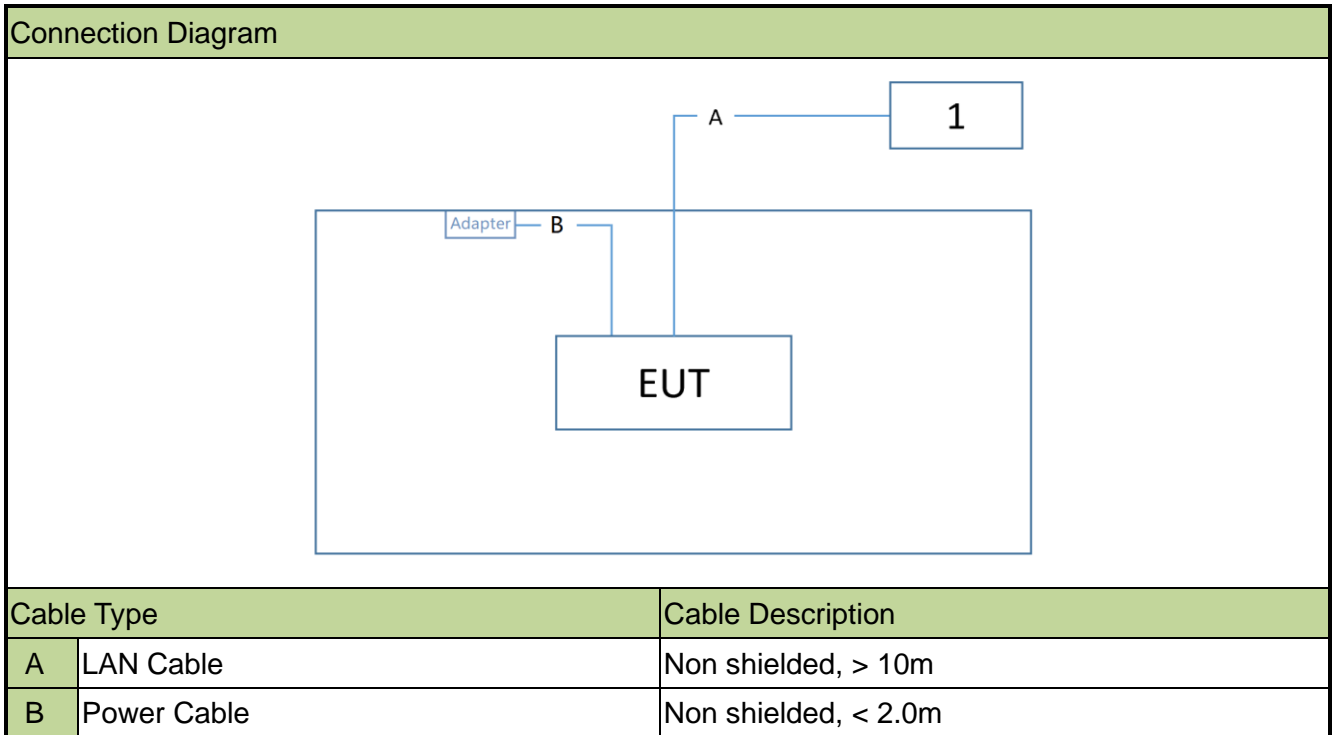

1.10. Test System Details

The types for all equipments, plus descriptions of all cables used in the tested system (including inserted cards) are:

Product	Manufacturer	Model No.
1	Notebook	Dell
		P62G

1.11. Test Software

The test utility software used during testing was "IPOP, and the version was "4.1".

1.12. Test Environment Condition

Ambient Temperature	15°C ~ 35°C
Relative Humidity	20%RH ~ 75%RH

1.13. Duty Cycle

Bluetooth-LE (DTS) operation is possible in channel bandwidths. The maximum achievable duty cycles for all modes were determined based on measurements performed on a spectrum analyzer in zero-span mode with RBW = 8MHz, VBW = 50MHz. The RBW and VBW were both greater than 50/T, where T is the minimum transmission duration, and the number of sweep points across T was greater than 100. The duty cycles are as follows:

Test Mode	Duty Cycle
BLE-1Mbps	62.0%

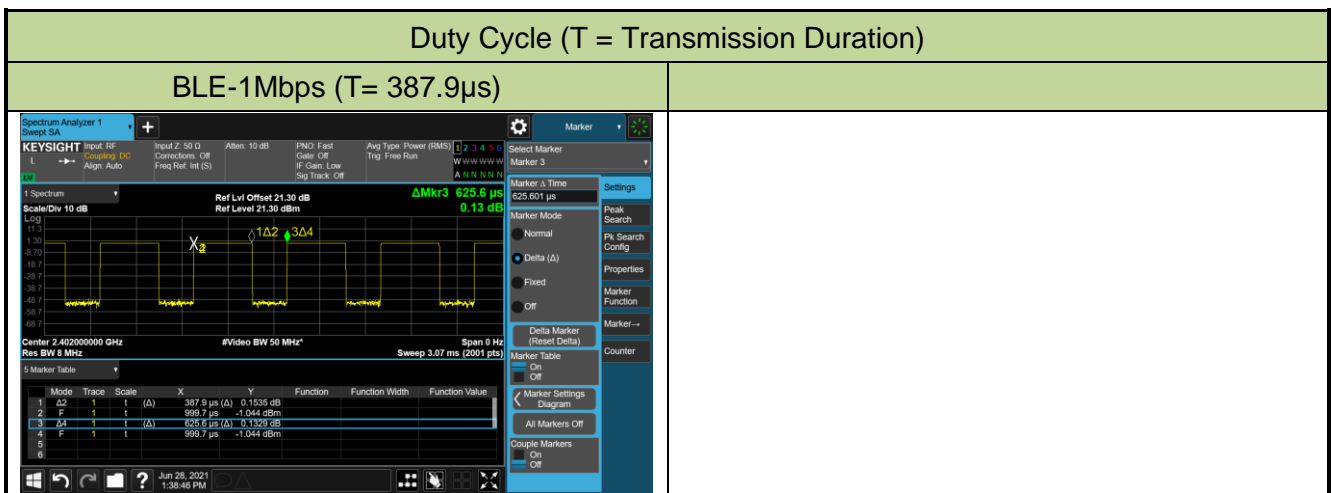

1.14. EMI Suppression Device(s)/Modifications

No EMI suppression device(s) were added and/or no modifications were made during testing.

2. ANTENNA REQUIREMENTS

Excerpt from §15.203 of the FCC Rules/Regulations:

“An intentional radiator antenna shall be designed to ensure that no antenna other than that furnished by the responsible party can be used with the device. The use of a permanently attached antenna or of an antenna that uses a unique coupling to the intentional radiator shall be considered sufficient to comply with the provisions of this section.”

- The antenna of the device is **permanently attached**.
- There are no provisions for connection to an external antenna.

Conclusion:

The unit complies with the requirement of §15.203.

3. TEST EQUIPMENT CALIBRATION DATE

Conducted Emission (WZ-SR2)

Instrument	Manufacturer	Type No.	Asset No.	Cali. Interval	Cali. Due Date
EMI Test Receiver	R&S	ESR3	MRTSUE06909	1 year	2021/11/22
Two-Line V-Network	R&S	ENV216	MRTSUE06002	1 year	2022/06/08
Thermal Hygrometer	testo	608-H1	MRTSUE06404	1 year	2022/06/28
Shielding Room	MIX-BEP	Chamber-SR2	MRTSUE06215	N/A	N/A

Conducted Emission (SIP-SR2)

Instrument	Manufacturer	Type No.	Asset No.	Cali. Interval	Cali. Due Date
EMI Test Receiver	R&S	ESR3	MRTSUE06613	1 year	2022/06/24
Two-Line V-Network	R&S	ENV216	MRTSUE06003	1 year	2022/06/08
Thermal Hygrometer	testo	608-H1	MRTSUE06621	1 year	2021/12/03

Radiated Emission (WZ-AC1)

Instrument	Manufacturer	Type No.	Asset No.	Cali. Interval	Cali. Due Date
EMI Test Receiver	R&S	ESR7	MRTSUE06001	1 year	2022/01/04
Loop Antenna	Schwarzbeck	FMZB 1519	MRTSUE06025	1 year	2021/11/08
Bilog Period Antenna	Schwarzbeck	VULB 9168	MRTSUE06172	1 year	2022/08/05
Horn Antenna	Schwarzbeck	BBHA 9120D	MRTSUE06023	1 year	2021/09/27
Horn Antenna	Schwarzbeck	BBHA9170	MRTSUE06597	1 year	2021/12/14
Microwave System Amplifier	Agilent	83017A	MRTSUE06076	1 year	2021/11/14
Preamplifier	Schwarzbeck	BBV 9721	MRTSUE06121	1 year	2022/06/10
Thermal Hygrometer	testo	608-H1	MRTSUE06403	1 year	2022/06/28
Anechoic Chamber	TDK	Chamber-AC1	MRTSUE06212	1 year	2022/04/29

Radiated Emission (WZ-AC2)

Instrument	Manufacturer	Type No.	Asset No.	Cali. Interval	Cali. Due Date
MXE EMI Receiver	Keysight	N9038A	MRTSUE06125	1 year	2022/06/24
Loop Antenna	Schwarzbeck	FMZB 1519	MRTSUE06025	1 year	2021/11/08
Bilog Period Antenna	Schwarzbeck	VULB 9162	MRTSUE06022	1 year	2022/05/24
Broad-Band Horn Antenna	Schwarzbeck	BBHA 9120D	MRTSUE06171	1 year	2021/10/25
Horn Antenna	Schwarzbeck	BBHA9170	MRTSUE06597	1 year	2021/12/14
Broadband Coaxial Preamplifier	Schwarzbeck	BBV 9718	MRTSUE06176	1 year	2021/11/14
Thermal Hygrometer	Minggao	ETH529	MRTSUE06170	1 year	2021/12/08
Anechoic Chamber	RIKEN	Chamber-AC2	MRTSUE06213	1 year	2022/04/29

Radiated Emission (SIP-AC1)

Instrument	Manufacturer	Type No.	Asset No.	Cali. Interval	Cali. Due Date
EMI Test Receiver	R&S	ESR3	MRTSUE06612	1 year	2022/06/24
EXA Signal Analyzer	Keysight	N9010B	MRTSUE06559	1 year	2022/06/24
Loop Antenna	Schwarzbeck	FMZB 1519 B	MRTSUE06937	1 year	2022/03/09
Bilog Period Antenna	Schwarzbeck	VULB9168	MRTSUE06645	1 year	2021/08/30
Double Ridged Horn Antenna	R&S	HF907	MRTSUE06610	1 year	2021/08/30
Preamplifier	EMCI	EMC051845SE	MRTSUE06600	1 year	2021/11/09
Thermal Hygrometer	testo	608-H1	MRTSUE06620	1 year	2021/12/03
Anechoic Chamber	RIKEN	SIP-AC1	MRTSUE06554	1 year	2021/12/24

Radiated Emission (SIP-AC2)

Instrument	Manufacturer	Type No.	Asset No.	Cali. Interval	Cali. Due Date
EMI Test Receiver	R&S	ESR3	MRTSUE06613	1 year	2022/06/24
MXA Signal Analyzer	Keysight	N9020B	MRTSUE06604	1 year	2021/09/26
Loop Antenna	Schwarzbeck	FMZB 1519 B	MRTSUE06937	1 year	2022/03/09
Bilog Period Antenna	Schwarzbeck	VULB9168	MRTSUE06646	1 year	2021/08/30
Horn Antenna	Schwarzbeck	BBHA9120D	MRTSUE06648	1 year	2021/11/26
Horn Antenna	Schwarzbeck	BBHA9170	MRTSUE06599	1 year	2021/11/26
Preamplifier	EMCI	EMC051845SE	MRTSUE06644	1 year	2021/11/09
Preamplifier	EMCI	EMC184045SE	MRTSUE06602	1 year	2021/10/12
Thermal Hygrometer	testo	608-H1	MRTSUE06624	1 year	2021/12/03
Anechoic Chamber	RIKEN	SIP-AC2	MRTSUE06781	1 year	2021/12/24

Radiated Emission (SIP-AC3)

Instrument	Manufacturer	Type No.	Asset No.	Cali. Interval	Cali. Due Date
Preamplifier	Schwarzbeck	BBV 9721	MRTSUE06121	1 year	2022/06/10
EMI Test Receiver	R&S	ESR3	MRTSUE06612	1 year	2022/06/24
EXA Signal Analyzer	Keysight	N9010B	MRTSUE06559	1 year	2022/06/24
Loop Antenna	Schwarzbeck	FMZB 1519	MRTSUE06025	1 year	2021/11/08
Bilog Period Antenna	Schwarzbeck	VULB9168	MRTSUE06646	1 year	2021/08/30
Double Ridged Horn Antenna	R&S	HF907	MRTSUE06611	1 year	2021/09/13
Horn Antenna	Schwarzbeck	BBHA9170	MRTSUE06598	1 year	2021/11/26
Preamplifier	EMCI	EMC012645SE	MRTSUE06642	1 year	2022/01/14
Thermal Hygrometer	testo	608-H1	MRTSUE06622	1 year	2021/12/03
Anechoic Chamber	RIKEN	SIP-AC3	MRTSUE06782	1 year	2021/12/24

Conducted Test Equipment (WZ-TR3)

Instrument	Manufacturer	Type No.	Asset No.	Cali. Interval	Cali. Due Date
EXA Signal Analyzer	Agilent	N9020A	MRTSUE06106	1 year	2022/04/13
EXA Signal Analyzer	Keysight	N9010B	MRTSUE06607	1 year	2022/01/06
Power Meter	Agilent	U2021XA	MRTSUE06030	1 year	2021/10/22
USB wideband power sensor	Keysight	U2021XA	MRTSUE06446	1 year	2022/06/08
USB wideband power sensor	Keysight	U2021XA	MRTSUE06447	1 year	2022/06/08
Bluetooth Test Set	Anritsu	MT8852B-042	MRTSUE06389	1 year	2022/06/08
Modulation Analyzer	HP	HP8901A	MRTSUE06098	1 year	2021/09/26
DC Power Supply	GWINSTEK	DPS-3303C	MRTSUE06064	N/A	N/A
Temperature & Humidity Chamber	BAOYT	BYH-150CL	MRTSUE06051	1 year	2021/10/22
Thermal Hygrometer	testo	608-H1	MRTSUE06401	1 year	2022/06/28

Conducted Test Equipment (SIP-TR1)

Instrument	Manufacturer	Type No.	Asset No.	Cali. Interval	Cali. Due Date
EXA Signal Analyzer	KEYSIGHT	N9010B	MRTSUE06603	1 year	2021/11/23
PXA Signal Analyzer	Keysight	N9030B	MRTSUE06395	1 year	2021/08/30
USB wideband power sensor	Agilent	U2021XA	MRTSUE06595	1 year	2021/09/26
USB wideband power sensor	Agilent	U2021XA	MRTSUE06596	1 year	2021/09/26
Temperature Chamber	BAOYT	BYG-408CS	MRTSUE06847	1 year	2022/02/23
Thermal Hygrometer	testo	608-H1	MRTSUE11022	1 year	2021/11/25

Software	Version	Function
EMI Software	V3	EMI Test Software

4. MEASUREMENT UNCERTAINTY

Where relevant, the following test uncertainty levels have been estimated for tests performed on the EUT as specified in CISPR 16-4-2. This uncertainty represents an expanded uncertainty expressed at approximately the 95% confidence level using a coverage factor of $k = 2$.

Conducted Emission Measurement
Measurement Uncertainty for a Level of Confidence of 95% ($U=2Uc(y)$): 9kHz~150kHz: 3.74dB 150kHz~30MHz: 3.44dB
Radiated Disturbance
Measurement Uncertainty for a Level of Confidence of 95% ($U=2Uc(y)$): Horizontal: 9kHz~300MHz: 5.04dB 300MHz~1GHz: 4.95dB 1GHz~6GHz: 6.40dB Vertical: 9kHz~300MHz: 5.24dB 300MHz~1GHz: 6.03dB 1GHz~40GHz: 6.40dB
Spurious Emissions, Conducted
Measuring Uncertainty for a Level of Confidence of 95% ($U=2Uc(y)$): 0.78dB
Output Power
Measuring Uncertainty for a Level of Confidence of 95% ($U=2Uc(y)$): 1.13dB
Power Spectrum Density
Measuring Uncertainty for a Level of Confidence of 95% ($U=2Uc(y)$): 1.15dB
Occupied Bandwidth
Measuring Uncertainty for a Level of Confidence of 95% ($U=2Uc(y)$): 0.28%

5. TEST RESULT

5.1. Summary

FCC Section(s)	Test Description	Test Limit	Test Condition	Test Result	Reference
15.247(a)(2)	6dB Bandwidth	$\geq 500\text{kHz}$	Conducted	Pass	Section 5.2
15.247(b)(3)	Output Power	$\leq 1\text{Watt (30dBm)}$ & $\text{EIRP} \leq 4\text{Watt (36dBm)}$		Pass	Section 5.3
15.247(e)	Power Spectral Density	$\leq 8\text{dBm/3kHz}$		Pass	Section 5.4
15.247(d)	Band Edge / Out-of-Band Emissions	20dBc		Pass	Section 5.5
15.205 15.209	General Field Strength Limits (Restricted Bands and Radiated Emission Limits)	Emissions in restricted bands must meet the radiated limits detailed in 15.209	Radiated	Pass	Section 5.6 & 5.7
15.207	AC Conducted Emissions 150kHz - 30MHz	< FCC 15.207 limits	Line Conducted	Pass	Section 5.8

Notes:

- 1) The analyzer plots shown in this section were all taken with a correction table loaded into the analyzer. The correction table was used to account for the losses of the cables and attenuators used as part of the system to connect the EUT to the analyzer at all frequencies of interest.

5.2. Occupied Bandwidth Measurement

5.2.1. Test Limit

The minimum 6dB bandwidth shall be at least 500 kHz.

5.2.2. Test Procedure used

ANSI C63.10-2013 - Section 11.8

5.2.3. Test Setting

1. The Spectrum's automatic bandwidth measurement capability was used to perform the 6dB bandwidth measurement. The "X" dB bandwidth parameter was set to $X = 6$. The bandwidth measurement was not influenced by any intermediate power nulls in the fundamental emission.
2. Set RBW = 100 kHz
3. $VBW \geq 3 \times RBW$
4. Detector = Peak
5. Trace mode = Max hold
6. Sweep = Auto couple
7. Allow the trace was allowed to stabilize

5.2.4. Test Setup

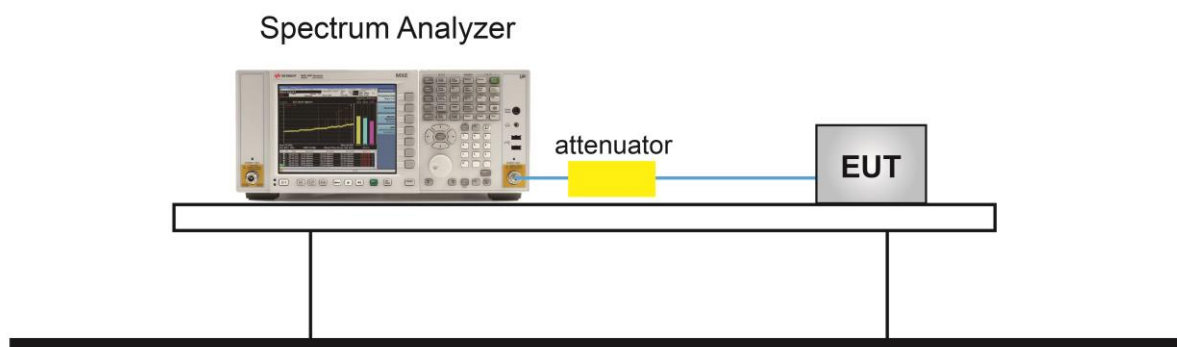

5.2.5. Test Result

Test Site	WZ-TR3	Test Engineer	Amy Zhang
Test Date	2021/06/28		

Test Mode	Data Rate (Mbps)	Channel No.	Frequency (MHz)	6dB Bandwidth (kHz)	Limit (kHz)	Result
BLE	1	00	2402	640.5	≥ 500	Pass
BLE	1	19	2440	642.4	≥ 500	Pass
BLE	1	39	2480	674.4	≥ 500	Pass

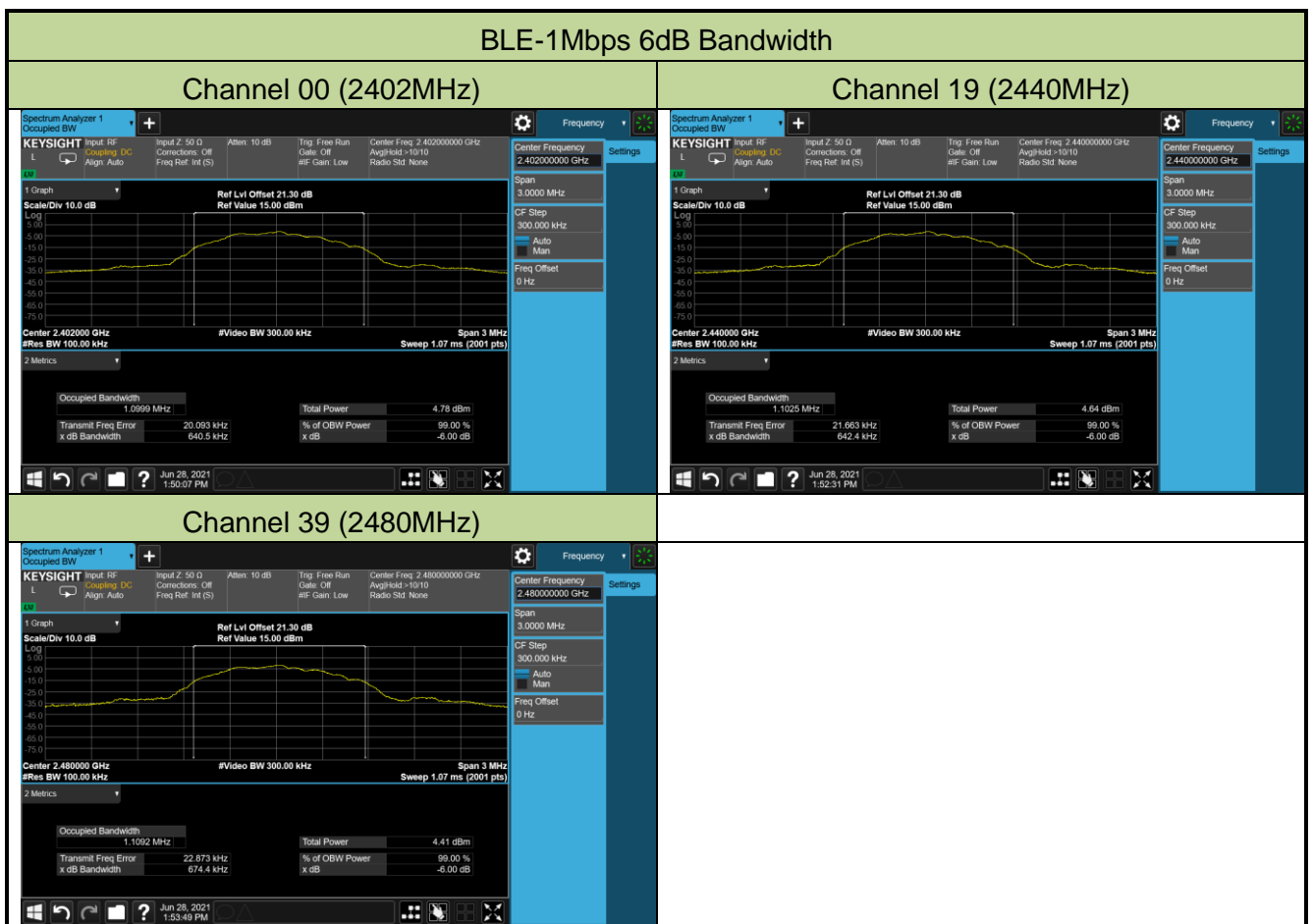

5.3. Output Power Measurement

5.3.1. Test Limit

The maximum out power shall be less 1 Watt (30dBm).

The conducted output power limit specified in paragraph FCC Part 15.247(b) of this section is based on the use of antennas with directional gains that do not exceed 6 dBi. If transmitting antennas of directional gain greater than 6 dBi are used, the conducted output power from the intentional radiator shall be reduced below the stated values in paragraphs FCC Part 15.247(b)(3) of this section, as appropriate, by the amount in dB that the directional gain of the antenna exceeds 6 dBi.

5.3.2. Test Procedure Used

ANSI C63.10-2013 - Section 11.9.1.3 PKPM1 Peak-reading power meter method

ANSI C63.10-2013 - Section 11.9.2.3.2 Method AVGPM-G

5.3.3. Test Setting

Method PKPM1 (Peak power measurement)

Peak power measurements were performed only when the EUT was transmitting at its maximum power control level using a broadband power meter with a pulse sensor. The pulse sensor employs a VBW = 50MHz so this method was only used for signals whose DTS bandwidth was less than or equal to 50MHz.

Method AVGPM-G (Measurement using a gated RF average-reading power meter)

Measurements may be performed using a wideband gated RF power meter provided that the gate parameters are adjusted such that the power is measured only when the EUT is transmitting at its maximum power control level. Since this measurement is made only during the ON time of the transmitter, no duty cycle correction is required.

5.3.4. Test Setup

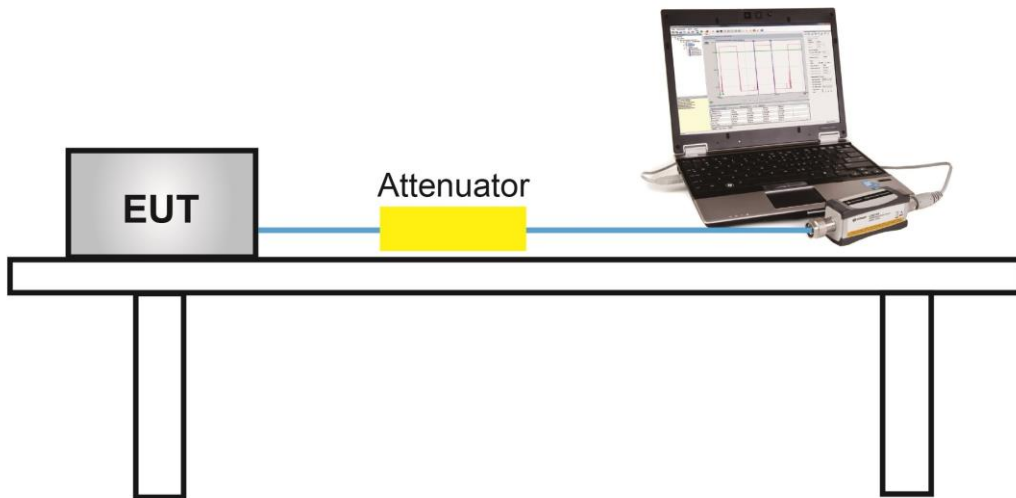

5.3.5. Test Result

Test Site	WZ-TR3	Test Engineer	Amy Zhang
Test Date	2021/06/29		

Test Mode	Data Rate (Mbps)	Channel No.	Frequency (MHz)	Peak Power (dBm)	Limit (dBm)	Result
Peak Output Power						
BLE	1	00	2402	1.86	≤ 30.00	Pass
BLE	1	19	2440	1.66	≤ 30.00	Pass
BLE	1	39	2480	1.67	≤ 30.00	Pass
Average Output Power (Reporting Only)						
BLE	1	00	2402	-0.76	≤ 30.00	Pass
BLE	1	19	2440	-0.82	≤ 30.00	Pass
BLE	1	39	2480	-1.06	≤ 30.00	Pass

5.4. Power Spectral Density Measurement

5.4.1. Test Limit

The maximum permissible power spectral density is 8dBm in any 3 kHz band.

The same method of determining the conducted output power shall be used to determine the power spectral density.

5.4.2. Test Procedure Used

ANSI C63.10-2013 - Section 11.10.2.

5.4.3. Test Setting

1. Analyzer was set to the center frequency of the DTS channel under investigation
2. Span = 1.5 times the DTS channel bandwidth
3. RBW = 3kHz
4. VBW = 10kHz
5. Detector = peak
6. Sweep time = auto couple
7. Trace mode = max hold
8. Trace was allowed to stabilize

5.4.4. Test Setup

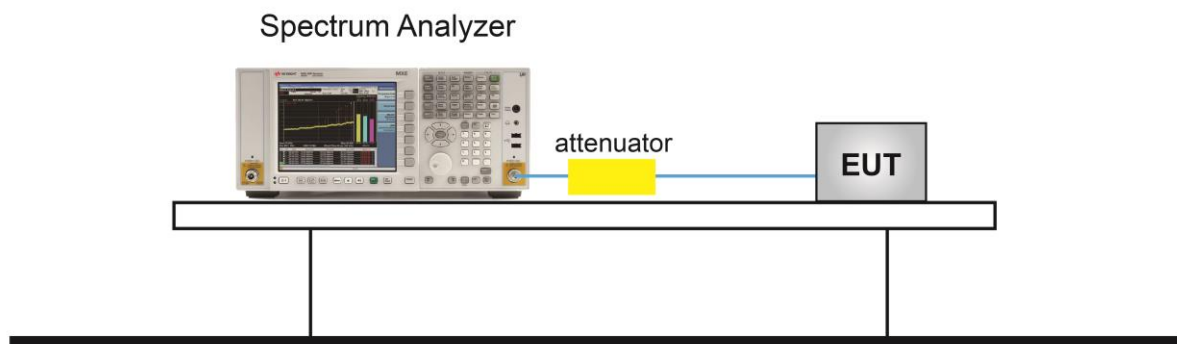

5.4.5. Test Result

Test Site	WZ-TR3	Test Engineer	Amy Zhang
Test Date	2021/06/28		

Test Mode	Data Rate (Mbps)	Channel No.	Frequency (MHz)	PSD Result (dBm / 3kHz)	Limit (dBm / 3kHz)	Result
BLE	1	00	2402	-7.77	≤ 8.00	Pass
BLE	1	19	2440	-7.70	≤ 8.00	Pass
BLE	1	39	2480	-7.74	≤ 8.00	Pass

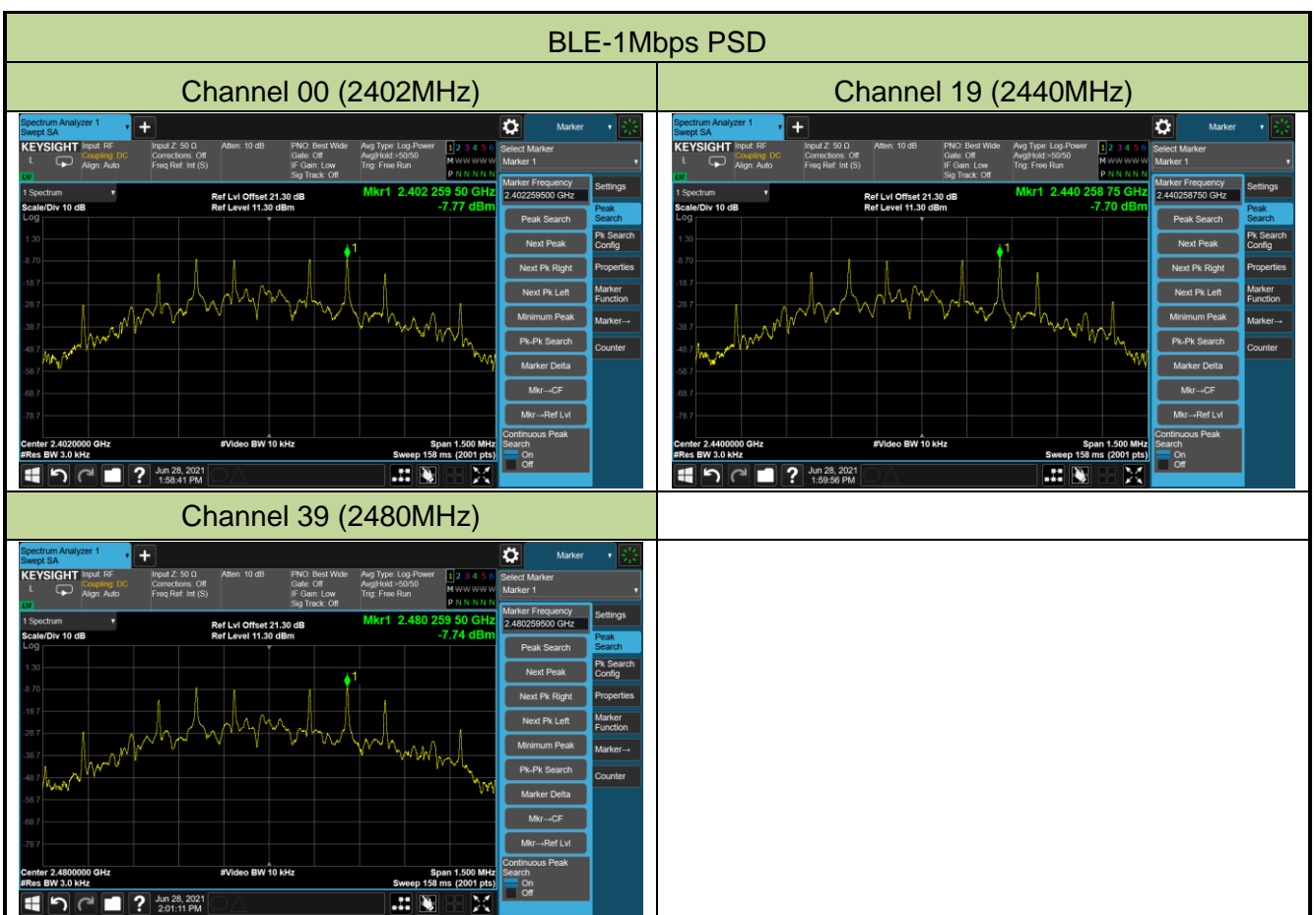

5.5. Conducted Band Edge and Out-of-Band Emissions

5.5.1. Test Limit

The limit for out-of-band spurious emissions at the band edge is 20dB below the fundamental emission level, as determined from the in-band power measurement of the DTS channel performed in a 100 kHz bandwidth per the PSD procedure.

5.5.2. Test Procedure Used

ANSI C63.10-2013 - Section 11.11.2 & 11.11.3.

5.5.3. Test Setting

Reference level measurement

1. Set instrument center frequency to DTS channel center frequency
2. Set the span to ≥ 1.5 times the DTS bandwidth
3. Set the RBW = 100 kHz
4. Set the VBW $\geq 3 \times$ RBW
5. Detector = peak
6. Sweep time = auto couple
7. Trace mode = max hold
8. Allow trace to fully stabilize

Emission level measurement

1. Set the center frequency and span to encompass frequency range to be measured
2. RBW = 100kHz
3. VBW = 300kHz
4. Detector = Peak
5. Trace mode = max hold
6. Sweep time = auto couple
7. The trace was allowed to stabilize

5.5.4. Test Setup

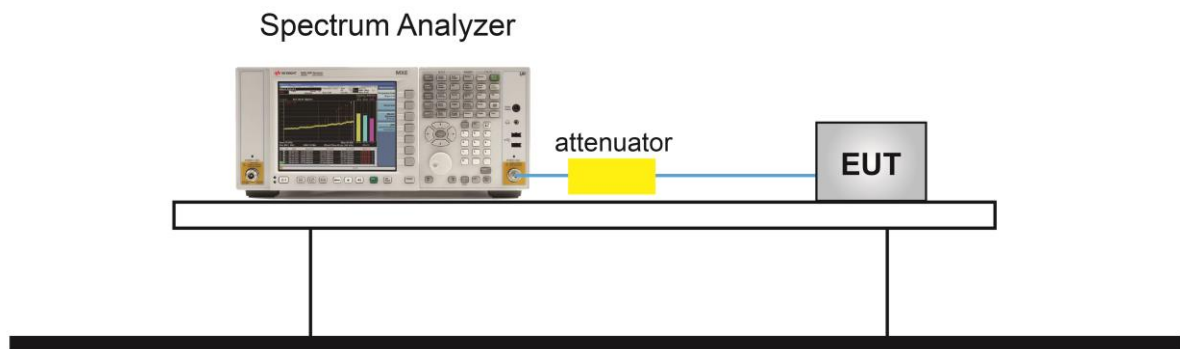

5.5.5. Test Result

Test Site	WZ-TR3	Test Engineer	Amy Zhang
Test Date	2021/06/28		

Test Mode	Data Rate / Mbps	Channel No.	Frequency (MHz)	Limit (dBc)	Result
BLE	1	00	2402	20	Pass
BLE	1	19	2440	20	Pass
BLE	1	39	2480	20	Pass

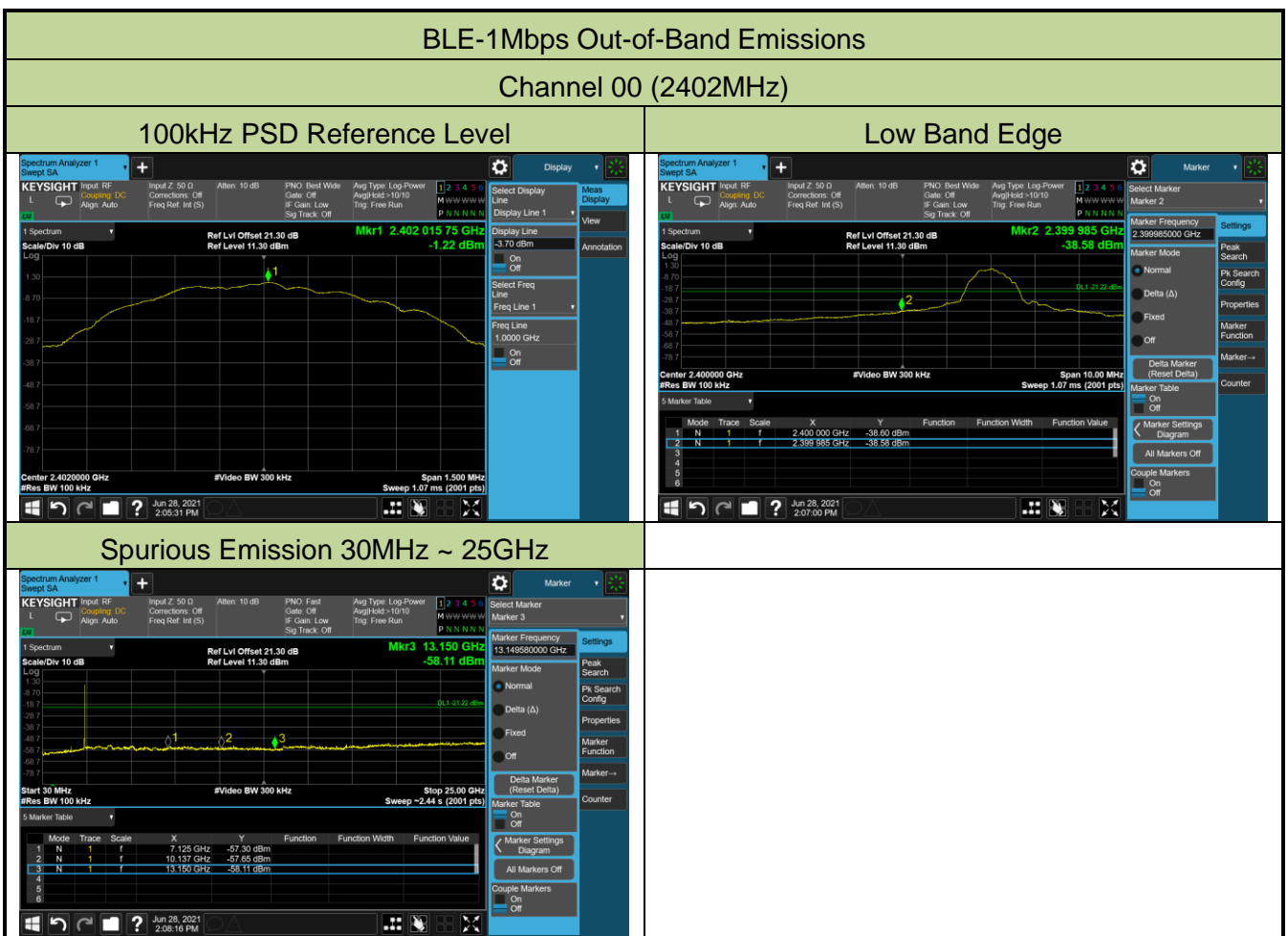

Channel 19 (2440MHz)

100kHz PSD Reference Level



Spurious Emission 30MHz ~ 25GHz

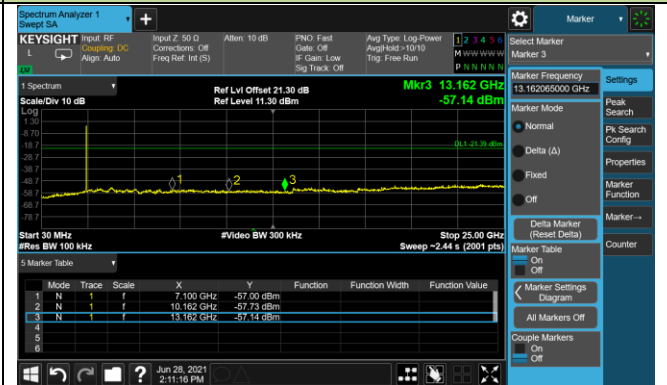

Channel 39 (2480MHz)

100kHz PSD Reference Level



High Band Edge

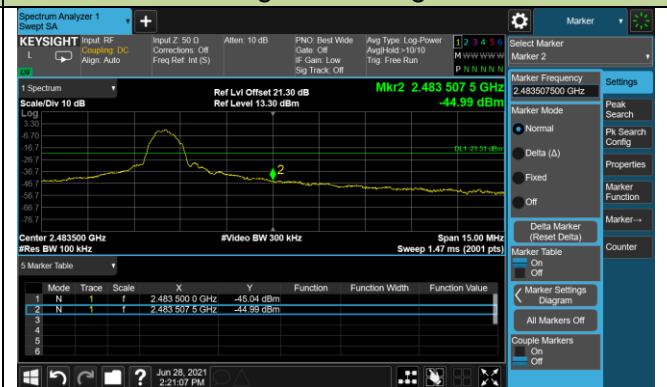

Spurious Emission 30MHz ~ 25GHz

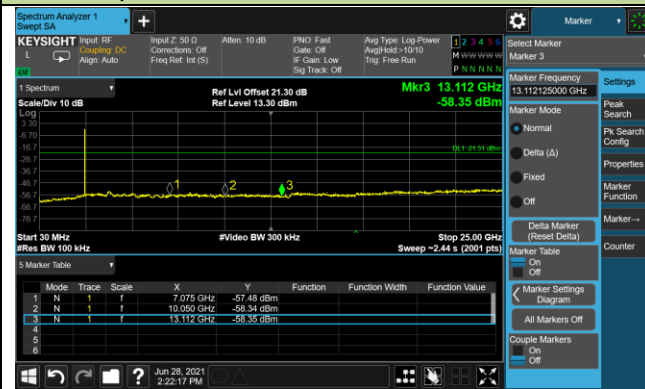

5.6. Radiated Spurious Emission Measurement

5.6.1. Test Limit

All out of band emissions appearing in a restricted band as specified in Section 15.205 of the Title 47CFR must not exceed the limits shown in Table per Section 15.209.

FCC Part 15 Subpart C Paragraph 15.209		
Frequency [MHz]	Field Strength [uV/m]	Measured Distance [Meters]
0.009 - 0.490	2400/F (kHz)	300
0.490 - 1.705	24000/F (kHz)	30
1.705 - 30	30	30
30 - 88	100	3
88 - 216	150	3
216 - 960	200	3
Above 960	500	3

5.6.2. Test Procedure Used

ANSI C63.10 Section 6.3 (General Requirements)

ANSI C63.10 Section 6.4 (Standard test method below 30MHz)

ANSI C63.10 Section 6.5 (Standard test method above 30MHz to 1GHz)

ANSI C63.10 Section 6.6 (Standard test method above 1GHz)

5.6.3. Test Setting

Table 1 - RBW as a function of frequency

Frequency	RBW
9 ~ 150 kHz	200 ~ 300 Hz
0.15 ~ 30 MHz	9 ~ 10 kHz
30 ~ 1000 MHz	100 ~ 120 kHz
> 1000 MHz	1 MHz

Quasi-Peak Measurements below 1GHz

1. Analyzer center frequency was set to the frequency of the radiated spurious emission of interest
2. Span was set greater than 1MHz
3. RBW = as specified in Table 1
4. Detector = CISPR quasi-peak
5. Sweep time = auto couple
6. Trace was allowed to stabilize

Peak Measurements above 1GHz

1. Analyzer center frequency was set to the frequency of the radiated spurious emission of interest
2. RBW = 1MHz
3. VBW = 3MHz
4. Detector = peak
5. Sweep time = auto couple
6. Trace mode = max hold
7. Trace was allowed to stabilize

Average Measurements above 1GHz (Method VB)

1. Analyzer center frequency was set to the frequency of the radiated spurious emission of interest
2. RBW = 1MHz
3. VBW; If the EUT is configured to transmit with duty cycle $\geq 98\%$, set VBW = 10 Hz.
If the EUT duty cycle is $< 98\%$, set VBW $\geq 1/T$. T is the minimum transmission duration.
4. Detector = Peak
5. Sweep time = auto
6. Trace mode = max hold
7. Trace was allowed to stabilize

5.6.4. Test Setup

Below 1GHz Test Setup:

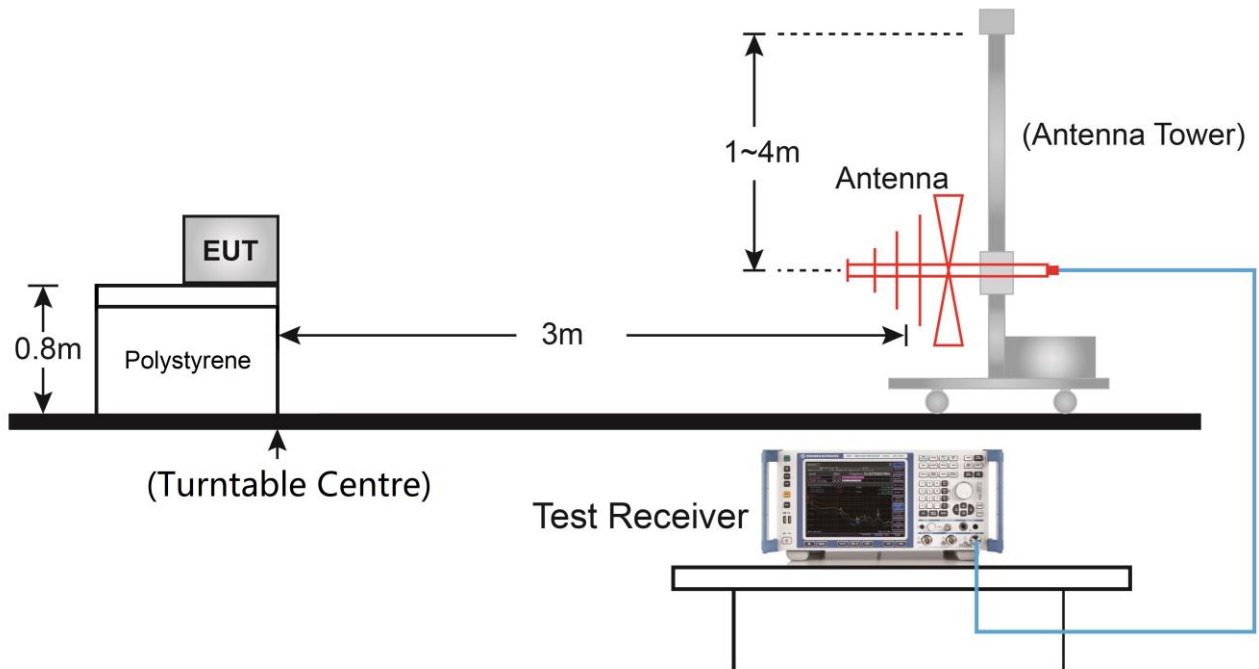

Above 1GHz Test Setup:

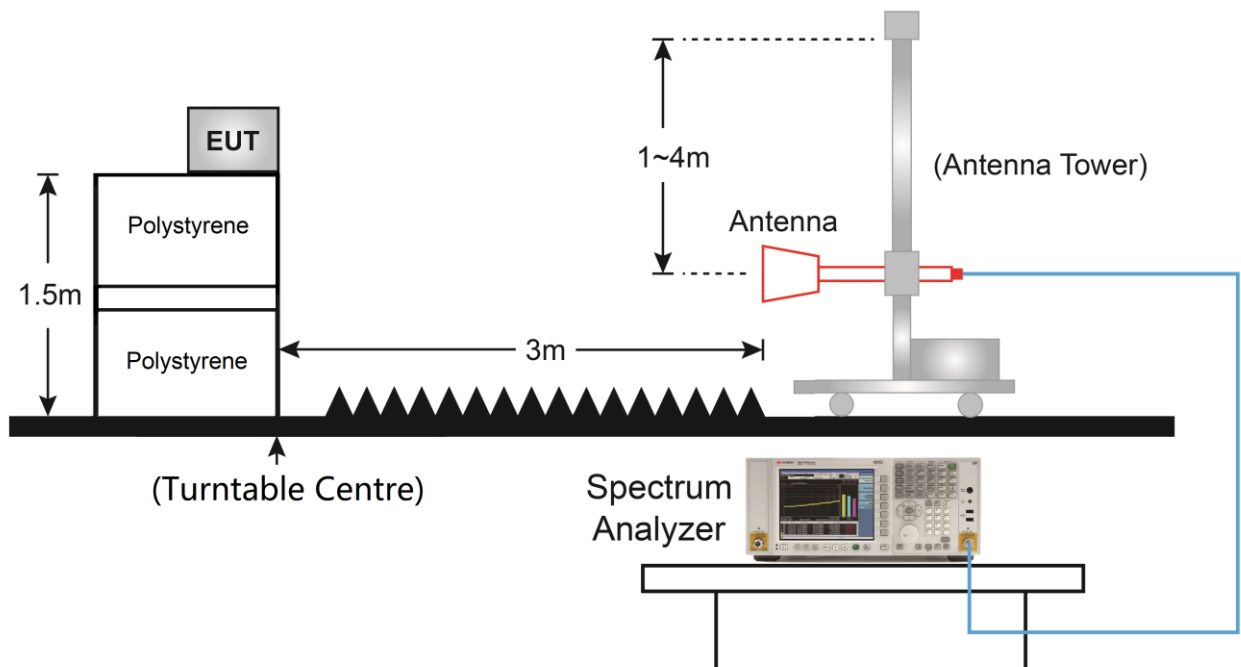

5.6.5. Test Result

Test Site	WZ-AC2	Test Engineer	Hyde Yu
Test Date	2021/06/30	Test Channel	00
Test Mode	BLE-1Mbps		
Note	1. Average measurement was not performed if peak level lower than average limit. 2. Other frequency was 20dB below limit line within 1-18GHz, there is not show in the report.		

Frequency (MHz)	Reading Level (dB μ V)	Factor (dB)	Measure Level (dB μ V/m)	Limit (dB μ V/m)	Margin (dB)	Detector	Polarization
4009.0	36.9	1.2	38.1	74.0	-35.9	Peak	Horizontal
4910.0	35.4	4.5	39.9	74.0	-34.1	Peak	Horizontal
7502.5	32.8	12.3	45.1	74.0	-28.9	Peak	Horizontal
4094.0	37.9	1.8	39.7	74.0	-34.3	Peak	Vertical
4850.5	36.4	4.5	40.9	74.0	-33.1	Peak	Vertical
7502.5	33.4	12.3	45.7	74.0	-28.3	Peak	Vertical

Note: Measure Level (dB μ V/m) = Reading Level (dB μ V) + Factor (dB)

Factor (dB) = Cable Loss (dB) + Antenna Factor (dB/m) - Pre_Amplifier Gain (dB)

Test Site	SIP-AC1	Test Engineer	Hyde Yu
Test Date	2021/06/30	Test Channel	19
Test Mode	BLE-1Mbps		
Note	1. Average measurement was not performed if peak level lower than average limit. 2. Other frequency was 20dB below limit line within 1-18GHz, there is not show in the report.		

Frequency (MHz)	Reading Level (dBμV)	Factor (dB)	Measure Level (dBμV/m)	Limit (dBμV/m)	Margin (dB)	Detector	Polarization
4077.0	36.8	1.6	38.4	74.0	-35.6	Peak	Horizontal
4782.5	35.6	4.5	40.1	74.0	-33.9	Peak	Horizontal
7409.0	33.5	12.4	45.9	74.0	-28.1	Peak	Horizontal
4094.0	36.9	1.8	38.7	74.0	-35.3	Peak	Vertical
4782.5	36.4	4.5	40.9	74.0	-33.1	Peak	Vertical
7468.5	33.7	12.1	45.8	74.0	-28.2	Peak	Vertical

Note: Measure Level (dBμV/m) = Reading Level (dBμV) + Factor (dB)

Factor (dB) = Cable Loss (dB) + Antenna Factor (dB/m) - Pre_Amplifier Gain (dB)

Test Site	SIP-AC1	Test Engineer	Hyde Yu
Test Date	2021/06/30	Test Channel	39
Test Mode	BLE-1Mbps		
Note	1. Average measurement was not performed if peak level lower than average limit. 2. Other frequency was 20dB below limit line within 1-18GHz, there is not show in the report.		

Frequency (MHz)	Reading Level (dB μ V)	Factor (dB)	Measure Level (dB μ V/m)	Limit (dB μ V/m)	Margin (dB)	Detector	Polarization
4026.0	36.9	1.4	38.3	74.0	-35.7	Peak	Horizontal
4859.0	35.9	4.5	40.4	74.0	-33.6	Peak	Horizontal
7468.5	32.7	12.1	44.8	74.0	-29.2	Peak	Horizontal
4085.5	37.4	1.7	39.1	74.0	-34.9	Peak	Vertical
4995.0	36.9	4.7	41.6	74.0	-32.4	Peak	Vertical
7468.5	33.6	12.1	45.7	74.0	-28.3	Peak	Vertical

Note: Measure Level (dB μ V/m) = Reading Level (dB μ V) + Factor (dB)

Factor (dB) = Cable Loss (dB) + Antenna Factor (dB/m) - Pre_Amplifier Gain (dB)

The Worst Case of Radiated Emission below 1GHz:

Site: SIP-AC1	Time: 2021/06/20 - 11:52
Limit: FCC_Part15.209_RE(3m)	Engineer: Mero Zhou
Probe: SIP-AC1_VULB 9168 _30-1000MHz	Polarity: Horizontal
EUT: WiFi 6 Extender	Power: AC 120V/60Hz
Test Mode: Transmit by BLE 1Mbps at Channel 2402MHz	

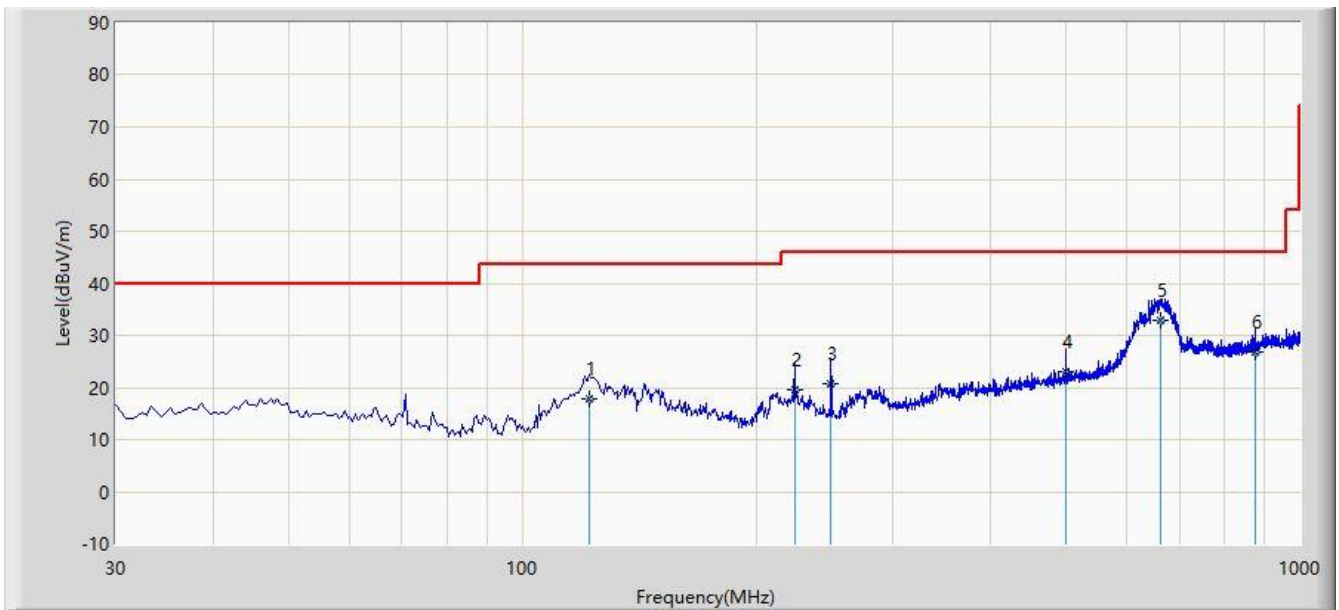

No	Flag	Mark	Frequency (MHz)	Measure Level (dBuV/m)	Reading Level (dBuV)	Margin (dB)	Limit (dBuV/m)	Factor (dB)	Type
1			122.150	17.866	2.090	-25.634	43.500	15.776	QP
2			224.000	19.487	4.710	-26.513	46.000	14.777	QP
3			249.705	20.681	4.150	-25.319	46.000	16.531	QP
4			499.965	23.052	0.350	-22.948	46.000	22.702	QP
5		*	662.925	32.913	7.150	-13.087	46.000	25.763	QP
6			875.355	26.695	-1.580	-19.305	46.000	28.275	QP

Note 1: Measure Level (dBuV/m) = Reading Level (dBuV) + Factor (dB)

Factor (dB) = Cable Loss (dB) + Antenna Factor (dB/m)

Note 2: The amplitude of radiated emissions (frequency range from 9kHz ~ 30MHz, 18GHz to 25GHz) is that proximity to ambient noise, which also are attenuated more than 20 dB below the permissible value. Therefore, the data is not presented in the report.

Site: SIP-AC1	Time: 2021/06/20 - 11:53
Limit: FCC_Part15.209_RE(3m)	Engineer: Mero Zhou
Probe: SIP-AC1_VULB 9168 _30-1000MHz	Polarity: Vertical
EUT: WiFi 6 Extender	Power: AC 120V/60Hz
Test Mode: Transmit by BLE 1Mbps at Channel 2402MHz	

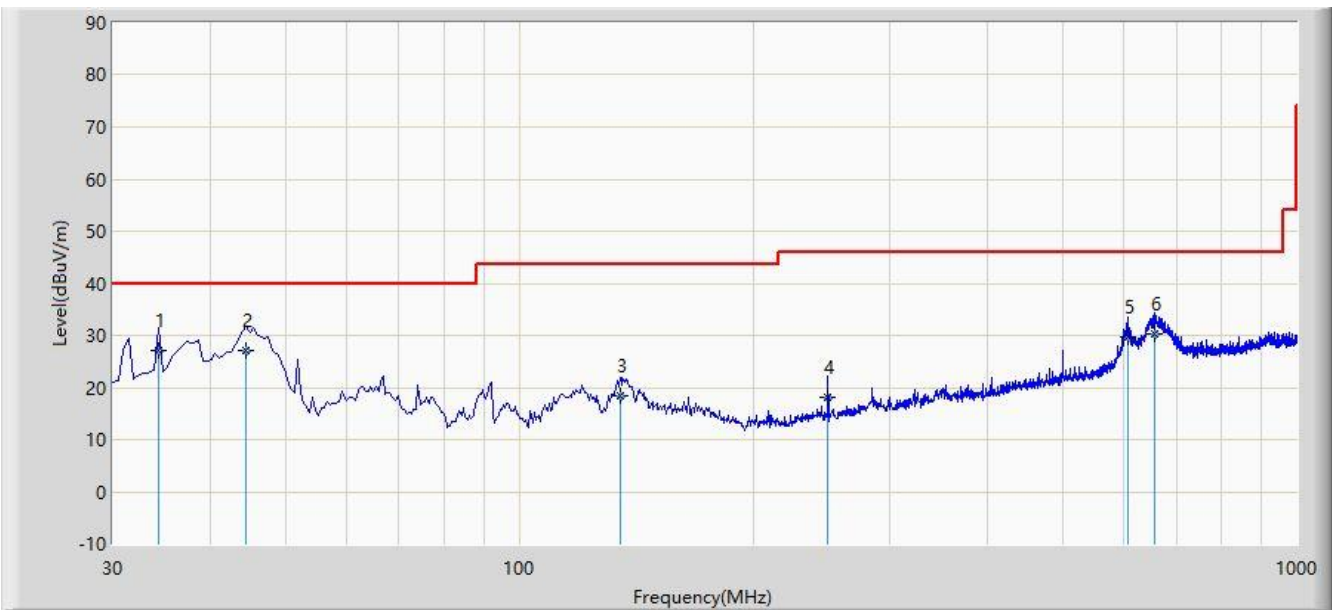

No	Flag	Mark	Frequency (MHz)	Measure Level (dBuV/m)	Reading Level (dBuV)	Margin (dB)	Limit (dBuV/m)	Factor (dB)	Type
1		*	34.365	27.140	10.220	-12.860	40.000	16.921	QP
2			44.550	27.126	9.320	-12.874	40.000	17.806	QP
3			134.760	18.360	1.410	-25.140	43.500	16.950	QP
4			249.705	18.181	1.650	-27.819	46.000	16.531	QP
5			607.150	29.767	4.580	-16.233	46.000	25.187	QP
6			657.105	30.306	4.560	-15.694	46.000	25.746	QP

Note 1: Measure Level (dB μ V/m) = Reading Level (dB μ V) + Factor (dB)

Factor (dB) = Cable Loss (dB) + Antenna Factor (dB/m)

Note 2: The amplitude of radiated emissions (frequency range from 9kHz ~ 30MHz, 18GHz to 25GHz) is that proximity to ambient noise, which also are attenuated more than 20 dB below the permissible value. Therefore, the data is not presented in the report.

5.7. Radiated Restricted Band Edge Measurement

5.7.1. Test Limit

For 15.205 requirement:

Radiated emissions which fall in the restricted bands, as defined in Section 15.205(a) of FCC part 15, must also comply with the radiated emission limits specified in Section 15.209(a).

Frequency (MHz)	Frequency (MHz)	Frequency (MHz)	Frequency (GHz)
0.090 - 0.110	16.42 - 16.423	399.9 - 410	4.5 - 5.15
¹ 0.495 - 0.505	16.69475 - 16.69525	608 - 614	5.35 - 5.46
2.1735 - 2.1905	16.80425 - 16.80475	960 - 1240	7.25 - 7.75
4.125 - 4.128	25.5 - 25.67	1300 - 1427	8.025 - 8.5
4.17725 - 4.17775	37.5 - 38.25	1435 - 1626.5	9.0 - 9.2
4.20725 - 4.20775	73 - 74.6	1645.5 - 1646.5	9.3 - 9.5
6.215 - 6.218	74.8 - 75.2	1660 - 1710	10.6 - 12.7
6.26775 - 6.26825	108 - 121.94	1718.8 - 1722.2	13.25 - 13.4
6.31175 - 6.31225	123 - 138	2200 - 2300	14.47 - 14.5
8.291 - 8.294	149.9 - 150.05	2310 - 2390	15.35 - 16.2
8.362 - 8.366	156.52475 - 156.52525	2483.5 - 2500	17.7 - 21.4
8.37625 - 8.38675	156.7 - 156.9	2690 - 2900	22.01 - 23.12
8.41425 - 8.41475	162.0125 - 167.17	3260 - 3267	23.6 - 24.0
12.29 - 12.293	167.72 - 173.2	3332 - 3339	31.2 - 31.8
12.51975 - 12.52025	240 - 285	3345.8 - 3358	36.43 - 36.5
12.57675 - 12.57725	322 - 335.4	3600 - 4400	(²)
13.36 - 13.41	--	--	--

All out of band emissions appearing in a restricted band as specified in Section 15.205 of the Title 47CFR must not exceed the limits shown in Table per Section 15.209.

FCC Part 15 Subpart C Paragraph 15.209 Limits		
Frequency [MHz]	Field Strength [uV/m]	Measured Distance [Meters]
0.009 - 0.490	2400/F (kHz)	300
0.490 - 1.705	24000/F (kHz)	30
1.705 - 30	30	30
30 - 88	100	3
88 - 216	150	3
216 - 960	200	3
Above 960	500	3

5.7.2. Test Procedure Used

ANSI C63.10 Section 6.3 (General Requirements)

ANSI C63.10 Section 6.6 (Standard test method above 1GHz)

5.7.3. Test Setting

Peak Field Strength Measurements

1. Analyzer center frequency was set to the frequency of the radiated spurious emission of interest
2. RBW = 1MHz
3. VBW = 3MHz
4. Detector = peak
5. Sweep time = auto couple
6. Trace mode = max hold
7. Trace was allowed to stabilize

Average Measurements above 1GHz (Method VB)

1. Analyzer center frequency was set to the frequency of the radiated spurious emission of interest
2. RBW = 1MHz
3. VBW; If the EUT is configured to transmit with duty cycle $\geq 98\%$, set VBW = 10 Hz.

If the EUT duty cycle is $< 98\%$, set $VBW \geq 1/T$. T is the minimum transmission duration.

4. Detector = Peak
5. Sweep time = auto
6. Trace mode = max hold
7. Trace was allowed to stabilize

5.7.4. Test Setup

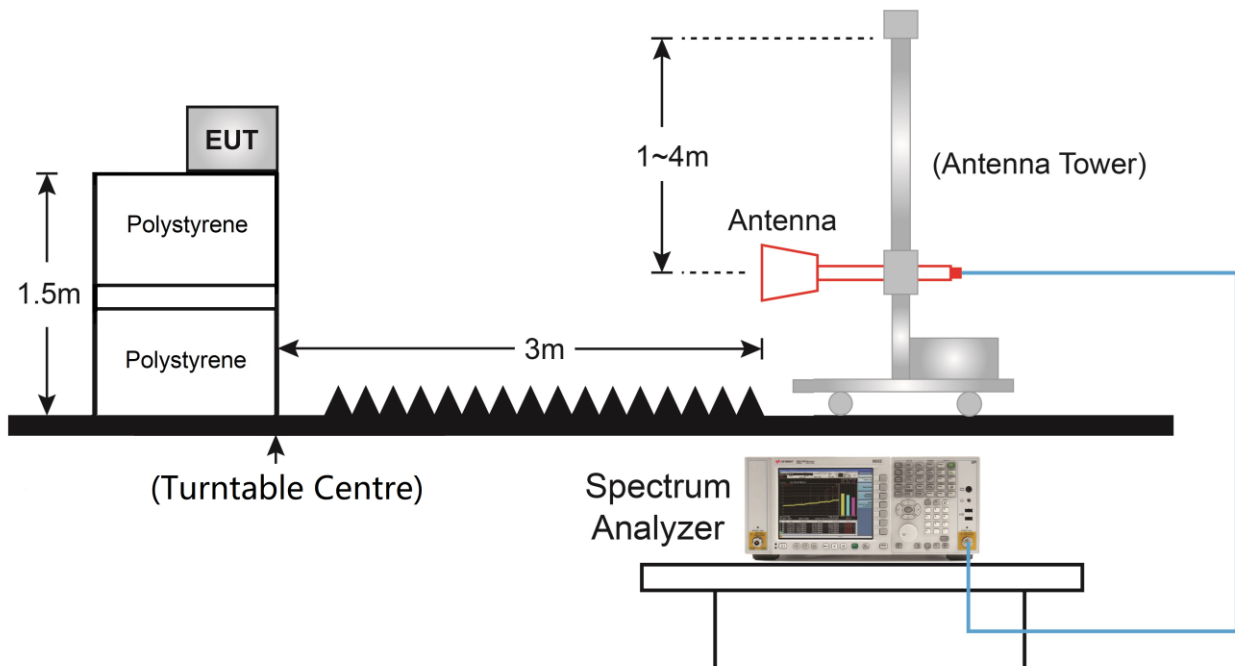

5.7.5. Test Result

Site: WZ-AC2	Time: 2021/05/18 - 19:00
Limit: FCC_Part15.209 (3m)	Engineer: Hyde Yu
Probe: WZ-AC2_BBHA9120D_1-18GHz	Polarity: Horizontal
EUT: WiFi 6 Extender	Power: AC 120V/60Hz
Test Mode: Transmit by BLE at Channel 2402MHz	

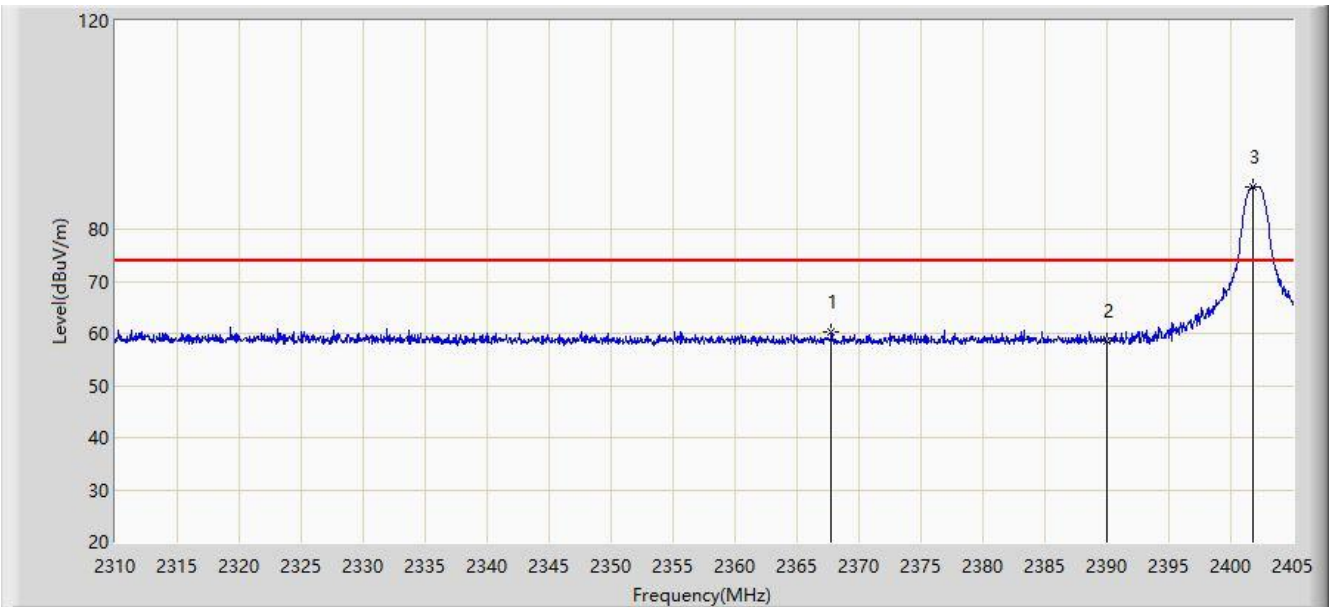

No	Flag	Mark	Frequency (MHz)	Measure Level (dBuV/m)	Reading Level (dBuV)	Margin (dB)	Limit (dBuV/m)	Factor (dB)	Type
1			2367.760	60.289	28.275	-13.711	74.000	32.015	PK
2			2390.000	58.476	26.473	-15.524	74.000	32.003	PK
3		*	2401.817	88.178	56.192	N/A	N/A	31.986	PK

Note: Measure Level (dB μ V/m) = Reading Level (dB μ V) + Factor (dB)

Factor (dB) = Cable Loss (dB) + Antenna Factor (dB/m)

Site: WZ-AC2	Time: 2021/05/18 - 19:05
Limit: FCC_Part15.209 (3m)	Engineer: Hyde Yu
Probe: WZ-AC2_BBHA9120D_1-18GHz	Polarity: Horizontal
EUT: WiFi 6 Extender	Power: AC 120V/60Hz
Test Mode: Transmit by BLE at Channel 2402MHz	

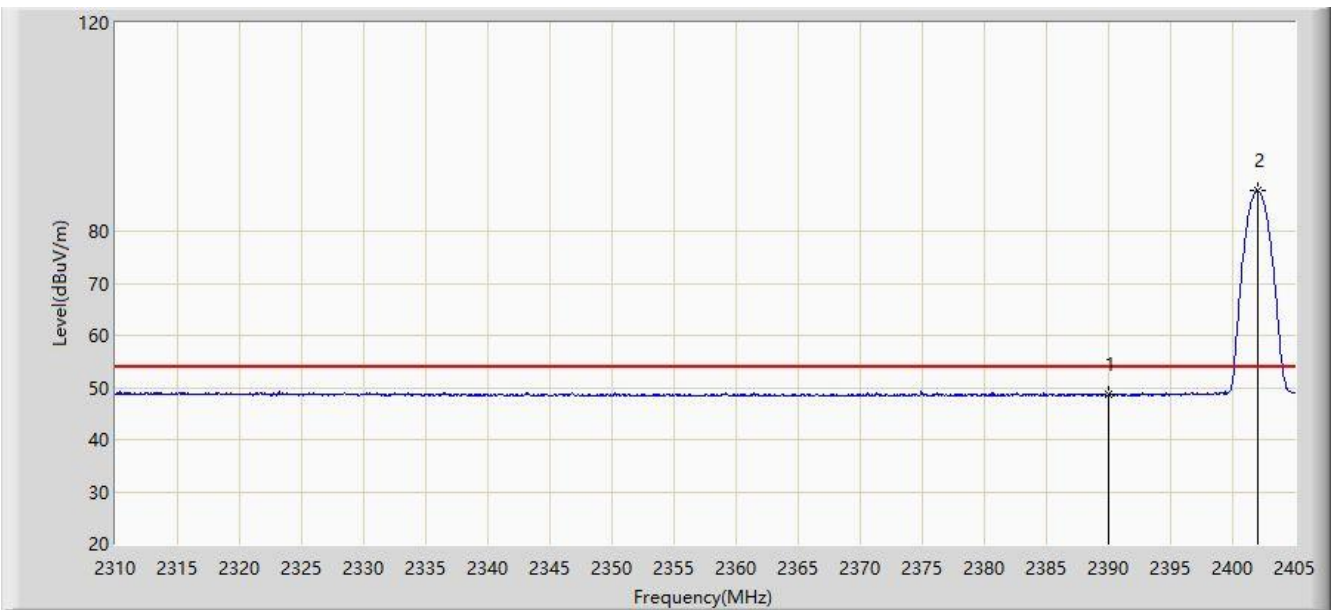

No	Flag	Mark	Frequency (MHz)	Measure Level (dBuV/m)	Reading Level (dBuV)	Margin (dB)	Limit (dBuV/m)	Factor (dB)	Type
1			2390.000	48.630	16.627	-5.370	54.000	32.003	AV
2		*	2402.008	87.871	55.885	N/A	N/A	31.986	AV

Note: Measure Level (dB μ V/m) = Reading Level (dB μ V) + Factor (dB)

Factor (dB) = Cable Loss (dB) + Antenna Factor (dB/m)

Site: WZ-AC2	Time: 2021/05/18 - 19:06
Limit: FCC_Part15.209 (3m)	Engineer: Hyde Yu
Probe: WZ-AC2_BBHA9120D_1-18GHz	Polarity: Vertical
EUT: WiFi 6 Extender	Power: AC 120V/60Hz
Test Mode: Transmit by BLE at Channel 2402MHz	

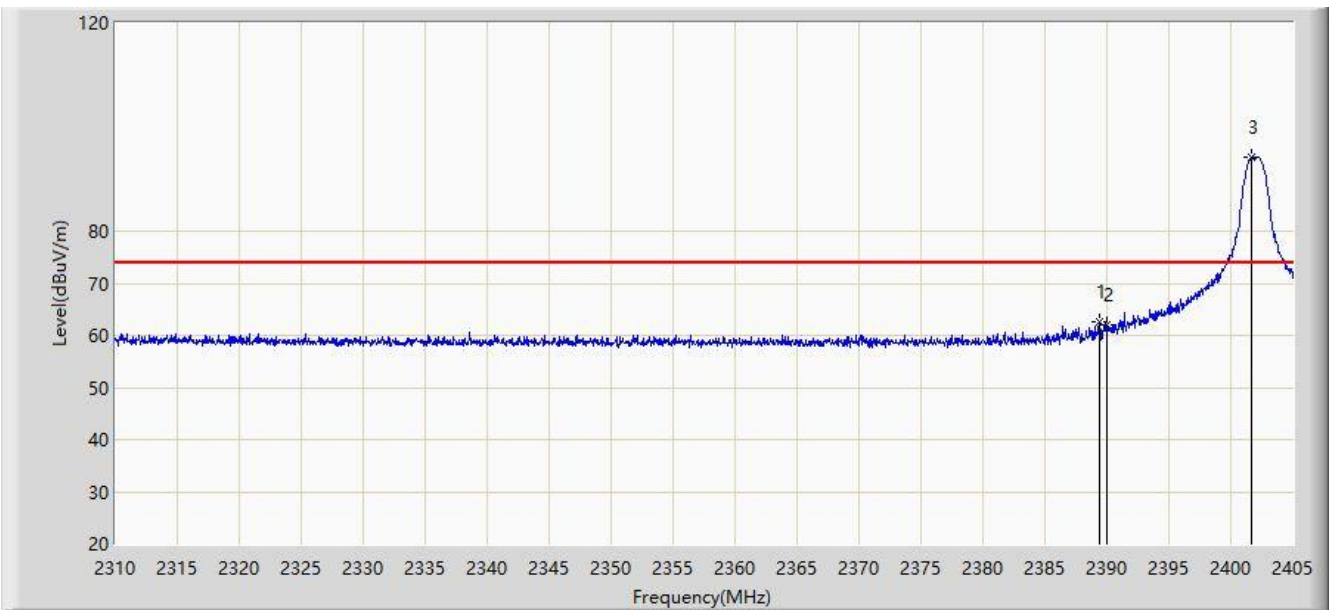

No	Flag	Mark	Frequency (MHz)	Measure Level (dBuV/m)	Reading Level (dBuV)	Margin (dB)	Limit (dBuV/m)	Factor (dB)	Type
1			2389.373	62.530	30.525	-11.470	74.000	32.005	PK
2			2390.000	61.951	29.948	-12.049	74.000	32.003	PK
3		*	2401.675	94.087	62.101	N/A	N/A	31.986	PK

Note: Measure Level (dB μ V/m) = Reading Level (dB μ V) + Factor (dB)

Factor (dB) = Cable Loss (dB) + Antenna Factor (dB/m)

Site: WZ-AC2	Time: 2021/05/18 - 19:08
Limit: FCC_Part15.209 (3m)	Engineer: Hyde Yu
Probe: WZ-AC2_BBHA9120D_1-18GHz	Polarity: Vertical
EUT: WiFi 6 Extender	Power: AC 120V/60Hz
Test Mode: Transmit by BLE at Channel 2402MHz	

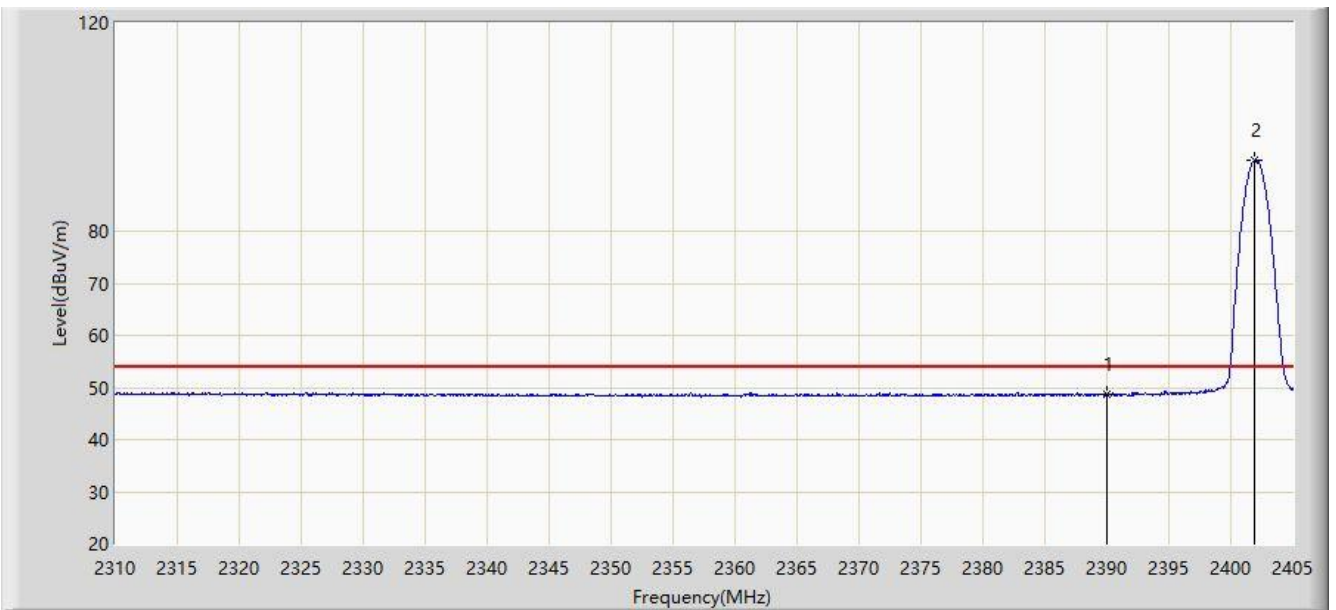

No	Flag	Mark	Frequency (MHz)	Measure Level (dBuV/m)	Reading Level (dBuV)	Margin (dB)	Limit (dBuV/m)	Factor (dB)	Type
1			2390.000	48.652	16.649	-5.348	54.000	32.003	AV
2		*	2401.865	93.542	61.556	N/A	N/A	31.986	AV

Note: Measure Level (dB μ V/m) = Reading Level (dB μ V) + Factor (dB)

Factor (dB) = Cable Loss (dB) + Antenna Factor (dB/m)

Site: WZ-AC2	Time: 2021/05/18 - 19:12
Limit: FCC_Part15.209 (3m)	Engineer: Hyde Yu
Probe: WZ-AC2_BBHA9120D_1-18GHz	Polarity: Horizontal
EUT: WiFi 6 Extender	Power: AC 120V/60Hz
Test Mode: Transmit by BLE at Channel 2480MHz	

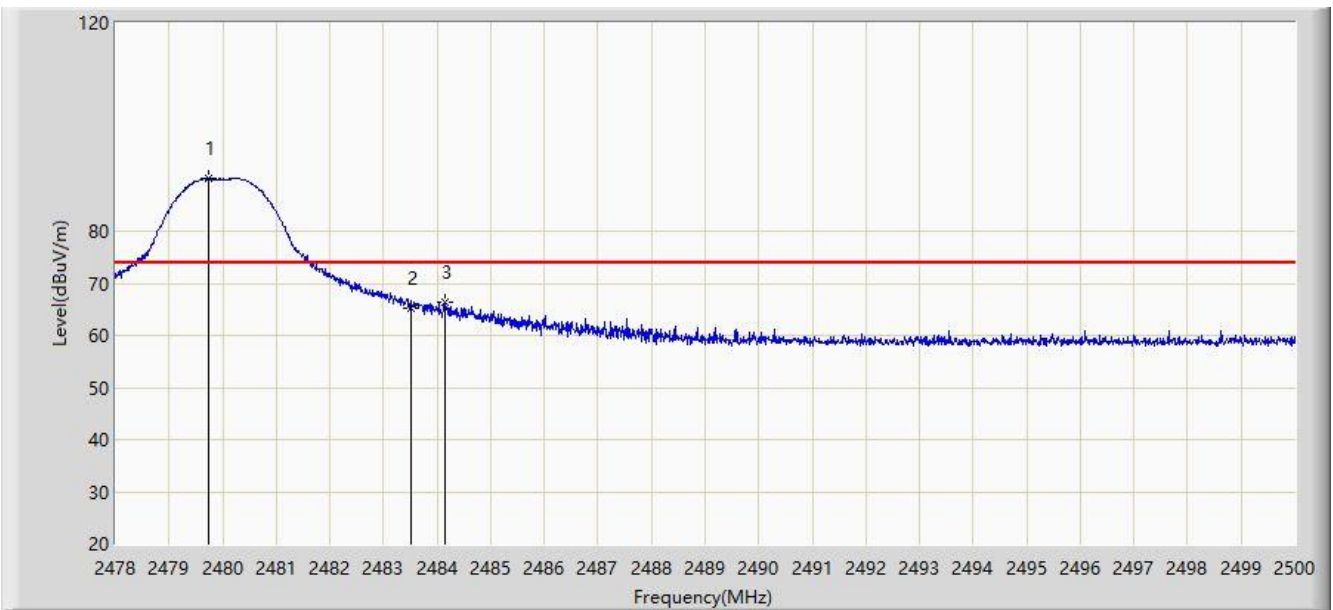

No	Flag	Mark	Frequency (MHz)	Measure Level (dBuV/m)	Reading Level (dBuV)	Margin (dB)	Limit (dBuV/m)	Factor (dB)	Type
1		*	2479.727	90.088	58.168	N/A	N/A	31.919	PK
2			2483.500	65.309	33.397	-8.691	74.000	31.912	PK
3			2484.138	66.456	34.546	-7.544	74.000	31.911	PK

Note: Measure Level (dB μ V/m) = Reading Level (dB μ V) + Factor (dB)

Factor (dB) = Cable Loss (dB) + Antenna Factor (dB/m)

Site: WZ-AC2	Time: 2021/05/18 - 19:14
Limit: FCC_Part15.209 (3m)	Engineer: Hyde Yu
Probe: WZ-AC2_BBHA9120D_1-18GHz	Polarity: Horizontal
EUT: WiFi 6 Extender	Power: AC 120V/60Hz
Test Mode: Transmit by BLE at Channel 2480MHz	

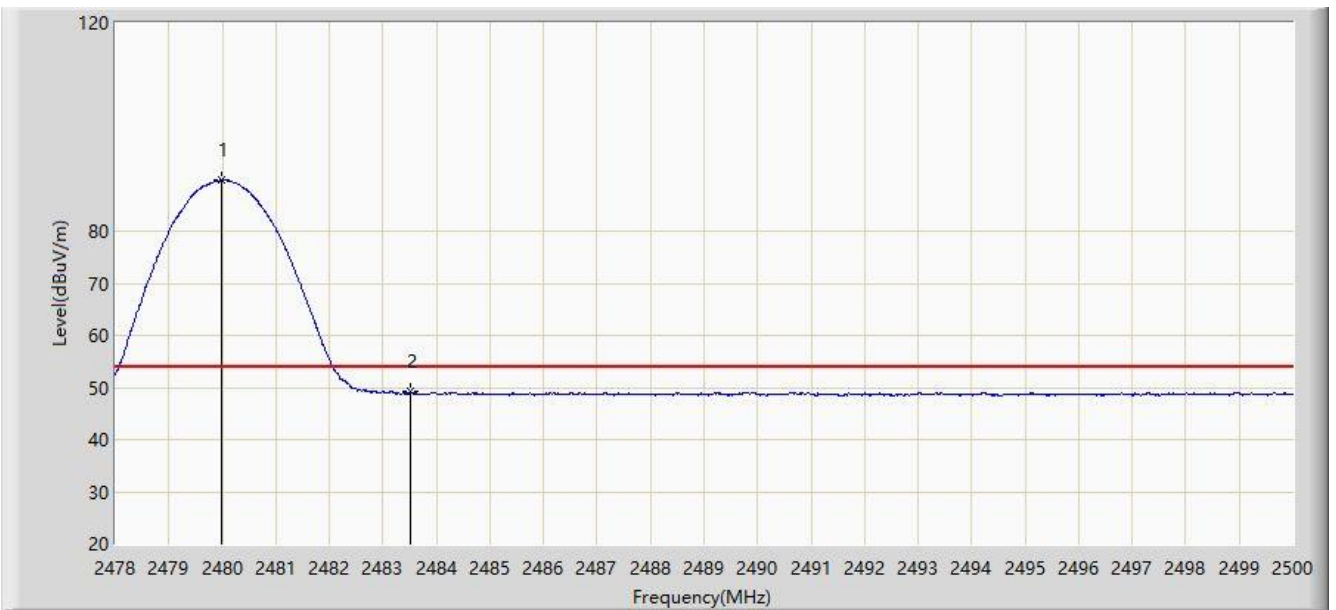

No	Flag	Mark	Frequency (MHz)	Measure Level (dBuV/m)	Reading Level (dBuV)	Margin (dB)	Limit (dBuV/m)	Factor (dB)	Type
1		*	2479.980	89.747	57.828	N/A	N/A	31.919	AV
2			2483.500	49.181	17.269	-4.819	54.000	31.912	AV

Note: Measure Level (dB μ V/m) = Reading Level (dB μ V) + Factor (dB)

Factor (dB) = Cable Loss (dB) + Antenna Factor (dB/m)

Site: WZ-AC2	Time: 2021/05/18 - 19:15
Limit: FCC_Part15.209 (3m)	Engineer: Hyde Yu
Probe: WZ-AC2_BBHA9120D_1-18GHz	Polarity: Vertical
EUT: WiFi 6 Extender	Power: AC 120V/60Hz
Test Mode: Transmit by BLE at Channel 2480MHz	

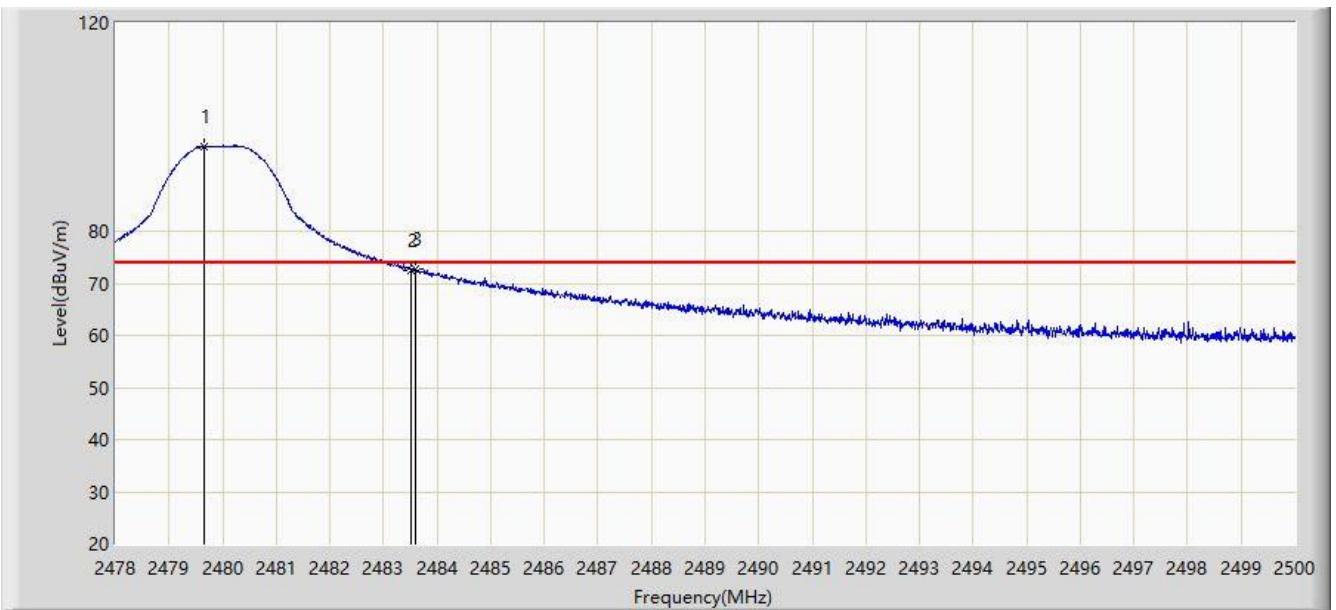

No	Flag	Mark	Frequency (MHz)	Measure Level (dBuV/m)	Reading Level (dBuV)	Margin (dB)	Limit (dBuV/m)	Factor (dB)	Type
1		*	2479.650	96.349	64.429	N/A	N/A	31.920	PK
2			2483.500	72.569	40.657	-1.431	74.000	31.912	PK
3			2483.599	72.779	40.867	-1.221	74.000	31.911	PK

Note: Measure Level (dB μ V/m) = Reading Level (dB μ V) + Factor (dB)

Factor (dB) = Cable Loss (dB) + Antenna Factor (dB/m)

Site: WZ-AC2	Time: 2021/05/18 - 19:18
Limit: FCC_Part15.209 (3m)	Engineer: Hyde Yu
Probe: WZ-AC2_BBHA9120D_1-18GHz	Polarity: Vertical
EUT: WiFi 6 Extender	Power: AC 120V/60Hz
Test Mode: Transmit by BLE at Channel 2480MHz	

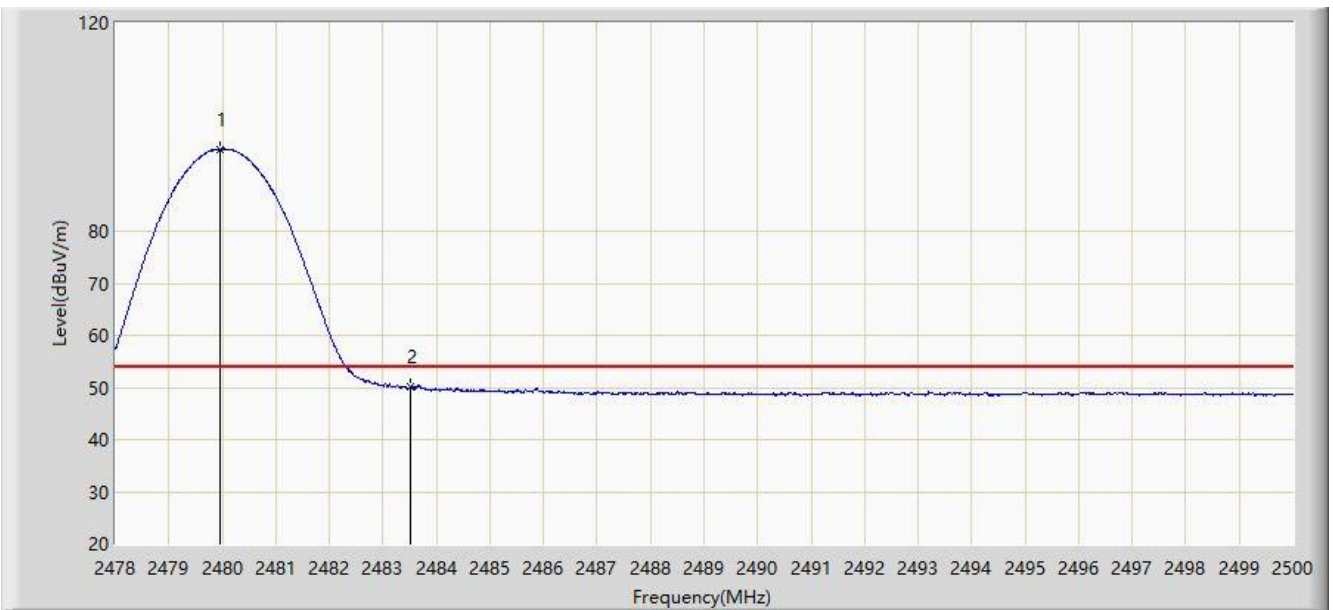

No	Flag	Mark	Frequency (MHz)	Measure Level (dBuV/m)	Reading Level (dBuV)	Margin (dB)	Limit (dBuV/m)	Factor (dB)	Type
1		*	2479.947	95.758	63.839	N/A	N/A	31.919	AV
2			2483.500	50.013	18.101	-3.987	54.000	31.912	AV

Note: Measure Level (dB μ V/m) = Reading Level (dB μ V) + Factor (dB)

Factor (dB) = Cable Loss (dB) + Antenna Factor (dB/m)

5.8. AC Conducted Emissions Measurement

5.8.1. Test Limit

FCC Part 15 Subpart C Paragraph 15.207 Limits		
Frequency (MHz)	QP (dBuV)	AV (dBuV)
0.15 - 0.50	66 - 56	56 - 46
0.50 - 5.0	56	46
5.0 - 30	60	50

Note 1: The lower limit shall apply at the transition frequencies.

Note 2: The limit decreases linearly with the logarithm of the frequency in the range 0.15MHz to 0.5MHz.

5.8.2. Test Setup

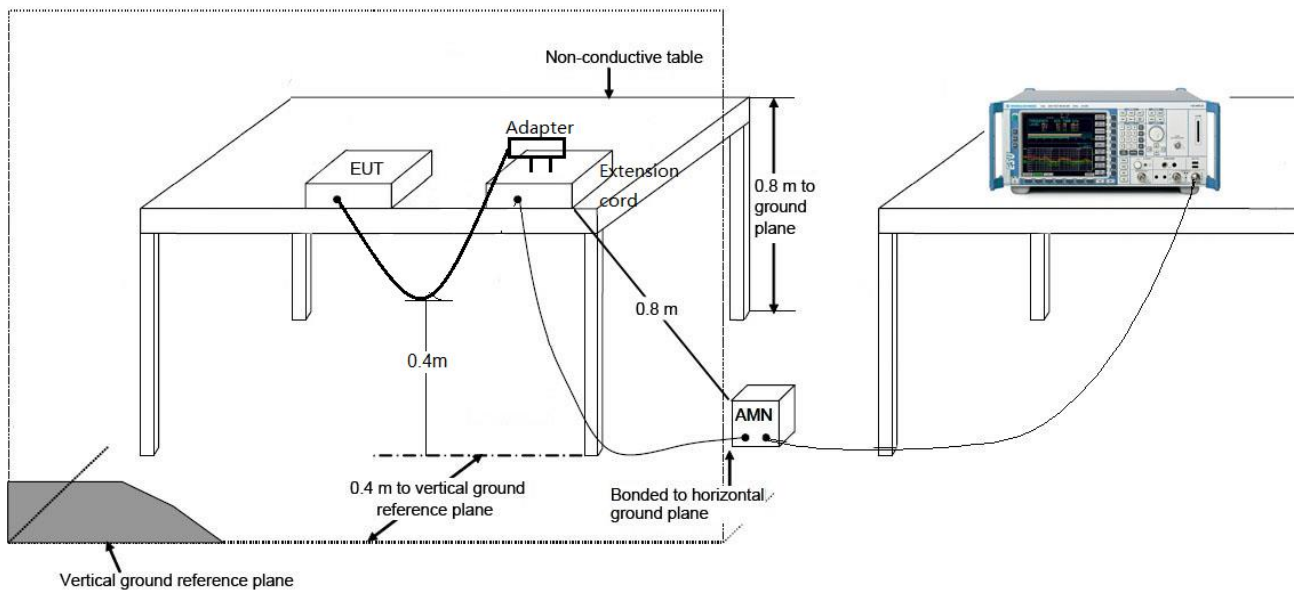

5.8.3. Test Result

Site: WZ-SR2	Time: 2021/07/29 - 17:46
Limit: FCC_Part15.207_CE_AC Power	Engineer: Linda Wei
Probe: ENV216_101683_Filter Off_E	Polarity: Line
EUT: WiFi 6 Extender	Power: AC 120V/60Hz
Test Mode: Transmit by BLE 1Mbps at Channel 2402MHz	

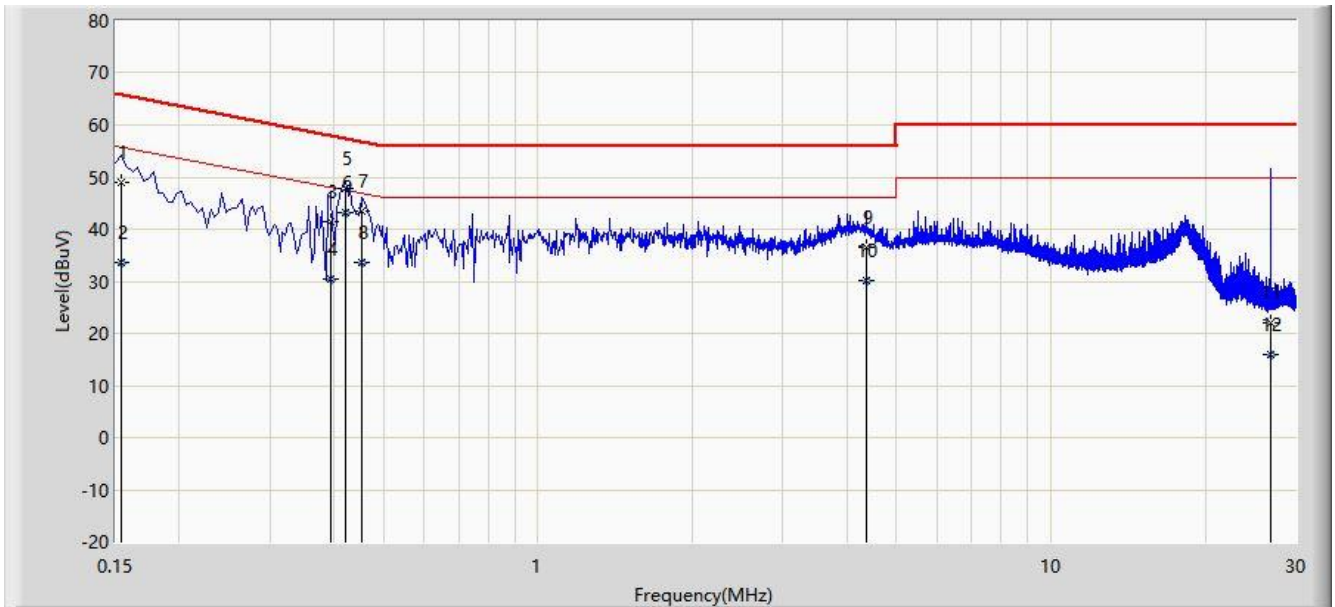

No	Flag	Mark	Frequency (MHz)	Measure Level (dBuV)	Reading Level (dBuV)	Margin (dB)	Limit (dBuV)	Factor (dB)	Type
1			0.154	49.036	39.048	-16.745	65.781	9.988	QP
2			0.154	33.544	23.556	-22.237	55.781	9.988	AV
3			0.394	41.527	31.523	-16.452	57.979	10.005	QP
4			0.394	30.333	20.329	-17.646	47.979	10.005	AV
5			0.422	47.921	37.914	-9.488	57.409	10.008	QP
6		*	0.422	43.249	33.242	-4.160	47.409	10.008	AV
7			0.454	43.536	33.525	-13.266	56.802	10.011	QP
8			0.454	33.730	23.719	-13.072	46.802	10.011	AV
9			4.374	36.509	25.611	-19.491	56.000	10.898	QP
10			4.374	30.151	19.253	-15.849	46.000	10.898	AV
11			26.814	22.118	4.836	-37.882	60.000	17.282	QP
12			26.814	15.903	-1.379	-34.097	50.000	17.282	AV

Note: Measure Level (dBμV) = Reading Level (dBμV) + Factor (dB)

Factor (dB) = Cable Loss (dB) + LISN Factor (dB).

Site: WZ-SR2	Time: 2021/07/29 - 17:53
Limit: FCC_Part15.207_CE_AC Power	Engineer: Linda Wei
Probe: ENV216_101683_Filter Off_E	Polarity: Neutral
EUT: WiFi 6 Extender	Power: AC 120V/60Hz
Test Mode: Transmit by BLE 1Mbps at Channel 2402MHz	

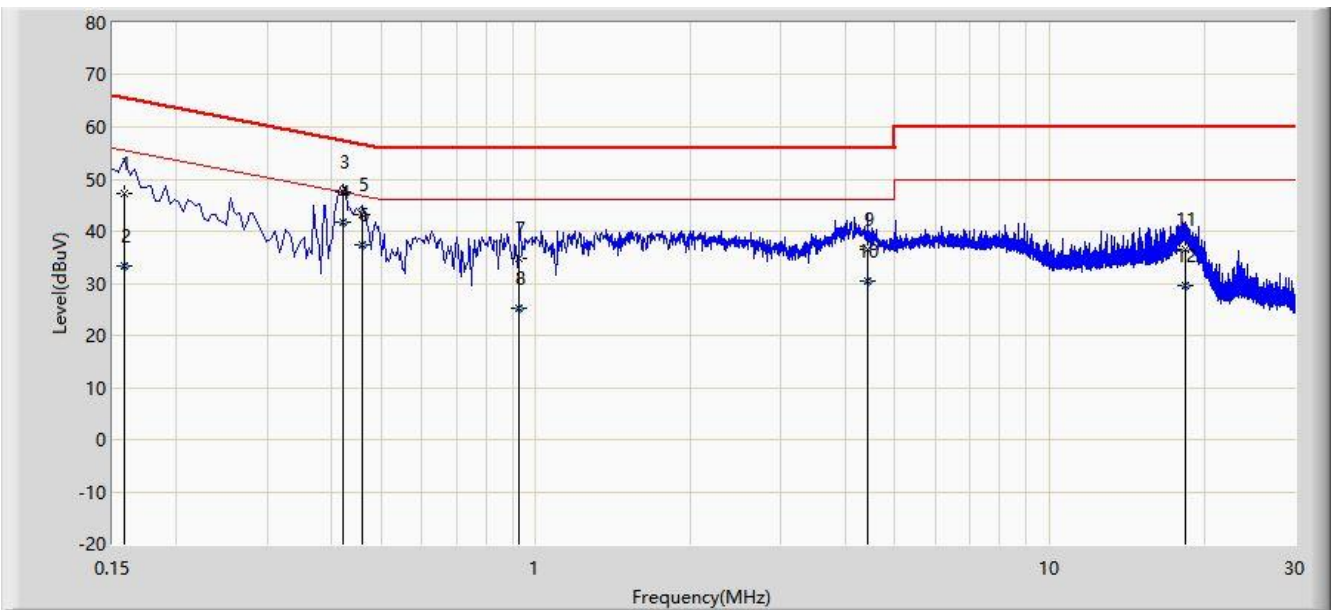

No	Flag	Mark	Frequency (MHz)	Measure Level (dBuV)	Reading Level (dBuV)	Margin (dB)	Limit (dBuV)	Factor (dB)	Type
1			0.158	47.376	37.346	-18.192	65.568	10.030	QP
2			0.158	33.474	23.443	-22.095	55.568	10.030	AV
3			0.422	47.398	37.353	-10.011	57.409	10.045	QP
4		*	0.422	41.775	31.731	-5.634	47.409	10.045	AV
5			0.458	43.262	33.215	-13.466	56.729	10.047	QP
6			0.458	37.418	27.371	-9.310	46.729	10.047	AV
7			0.930	34.646	24.553	-21.354	56.000	10.092	QP
8			0.930	25.219	15.126	-20.781	46.000	10.092	AV
9			4.430	36.625	25.688	-19.375	56.000	10.938	QP
10			4.430	30.489	19.552	-15.511	46.000	10.938	AV
11			18.430	36.618	21.397	-23.382	60.000	15.220	QP
12			18.430	29.494	14.274	-20.506	50.000	15.220	AV

Note: Measure Level (dB μ V) = Reading Level (dB μ V) + Factor (dB)

Factor (dB) = Cable Loss (dB) + LISN Factor (dB).

6. CONCLUSION

The data collected relate only the item(s) tested and show that the device is compliance with Part 15C of the FCC rules and ISED rules.

Appendix A - Test Setup Photograph

Refer to "2105RSU006-UT" file.

Appendix B - EUT Photograph

Refer to " 2105RSU006-UE" file.