

TEST REPORT

Report Number: 17031392HKG-001

Application For Original Grant of FCC Part 95 Certification

FCC ID: SF8KDWT2017

TESTED AND PREPARED BY:

APPROVED BY:

Signed On File
Koo Wai Ip
Technical Supervisor

Nip Ming Fung, Melvin
Manager
Date: June 14, 2017

Intertek's standard Terms and Conditions can be obtained at our website <http://www.intertek.com/terms/>.

The test report only allows to be revised within the retention period unless further standard or the requirement was noticed

This report is for the exclusive use of Intertek's Client and is provided pursuant to the agreement between Intertek and its Client. Intertek's responsibility and liability are limited to the terms and conditions of the agreement. Intertek assumes no liability to any party, other than to the Client in accordance with the agreement, for any loss, expense or damage occasioned by the use of this report. Only the Client is authorized to permit copying or distribution of this report and then only in its entirety. Any use of the Intertek name or one of its marks for the sale or advertisement of the tested material, product or service must first be approved in writing by Intertek. The observations and test results in this report are relevant only to the sample tested. This report by itself does not imply that the material, product, or service is or has ever been under an Intertek certification program.

© 2017 Intertek

TEST REPORT

GENERAL INFORMATION

Grantee:	King Da Plastic Electronic Ltd.
Grantee Address:	No.49 Pu Xia Road, Heng Gang Jie Dao, Long Gang Qu, Shenzhen City, China.
FCC Specification Standard:	FCC Part 95
FCC ID:	SF8KDWT2017
FCC Model(s):	2720022
Brand Name:	Watch WalkieTalkie
Type of EUT:	Watch WalkieTalkie
Description of EUT:	Watch WalkieTalkie
Serial Number:	N/A
Sample Receipt Date:	March 24, 2017
Date of Test:	April 18 - June 5, 2017
Report Date:	June 14, 2017

TEST REPORT**MEASUREMENT/TECHNICAL REPORT**This report concerns (check one:) Original Grant Class II Change Equipment Type: FRT – Part 95 Family Radio Body Worn TransmitterDeferred grant requested per 47 CFR 0.457(d)(1)(ii)? Yes No If yes, defer until: _____
dateCompany Name agrees to notify the Commission by: _____
date

of the intended date of announcement of the product so that the grant can be issued on that date.

Report prepared by:

Nip Ming Fung, Melvin
Intertek Testing Services Hong Kong Ltd.
2/F., Garment Centre,
576 Castle Peak Road,
Kowloon, Hong Kong.
Phone: 852-2173-8535
Fax: 852-2741-1693

TEST REPORT

TABLE OF CONTENTS

1.0 General Description	5
1.1 Product Description	5
1.2 Related Submittal(s) Grants	6
1.3 Test Methodology	6
1.4 Test Facility	6
2.0 System Test Configuration	7
2.1 Justification	7
2.2 EUT Exercising Software	8
2.3 Special Accessories	8
2.4 Measurement Uncertainty	8
2.5 Equipment Modification	8
2.6 Support Equipment	8
3.0 RF Power Output	9
4.0 Modulation Characteristics	12
4.1 Modulation Frequency Response	13
4.2 Modulation Limiting Characteristics	16
4.3 Audio Low Pass Filter Response	19
5.0 Occupied Bandwidth	22
6.0 Spurious Emission	25
6.1 Power of Spurious Radiation	26
7.0 Frequency Stability	30
7.1 Frequency Tolerance	30
7.2 Temperature Extreme Condition	32
7.3 Voltage Extreme Condition	34
8.0 Equipment List	36

TEST REPORT

EXHIBIT 1 GENERAL DESCRIPTION

1.0 General Description

1.1 Product Description

The Equipment Under Test (EUT) is a Watch Walkie Talkie with FRS which operate between 462.5625MHz to 462.7125MHz.

The EUT is powered by 3 x 1.5V AAA sized Alkaline batteries.

Transmitter Portion

- (i) Type of Emission : 5K60F3E with filtering
- (ii) Frequency Range : FRS: 462.5625MHz to 462.7125MHz
- (iii) Maximum Power Rating : 0.002W ERP
- (iv) Antenna Type : Integral, vertically polarized with 2.05dBi antenna gain
- (iv) dc voltage of radio frequency amplifying device: 4.5V
- dc current of radio frequency amplifying device : 800mA

CHANNEL	FREQUENCY (MHz)
1	462.5625
2	462.5875
3	462.6125
4	462.6375
5	462.6625
6	462.6875
7	462.7125

TEST REPORT

1.2 Related Submittal(s) Grants

This is an Application for Certification of the transmitter portion of a FRS Transceiver.
The receiver section of this Transceiver and digital device portion is subject to verification process.

1.3 Test Methodology

Radiated emission measurements were performed according to the procedures in ANSI C63.4 (2014) and ANSI/TIA-603-C-2004. Conducted emission measurement were performed according to the procedures in ANSI C63.4 (2014). All radiated measurement were performed in 3m Chamber. All Radiated tests were performed at an antenna the EUT distance of 3 meters, unless stated otherwise in the “**Justification Section**” of this Application.

1.4 Test Facility

The 3m Chamber for radiated emission test is located at HKPC Building, 78 Tat Chee Avenue, Kowloon, Hong Kong and conducted measurement facility used to collect the radiated data is located at Workshop No. 3, G/F., World-Wide Industrial Centre, 43-47 Shan Mei Street, Fo Tan, Sha Tin, N.T., Hong Kong. These test facility and site measurement data have been placed on file with the FCC.

TEST REPORT

EXHIBIT 2 SYSTEM TEST CONFIGURATION

2.0 System Test Configuration

2.1 Justification

The device was configured for testing in a typical fashion (as a customer would normally use it). The device was placed on a turntable, which enabled the engineer to maximize emissions through its placement in the three orthogonal axes. The device has been tested with headset and without headset when the radiated emissions are measured.

The device was powered by 3 x 1.5V AAA sized Alkaline batteries.

The frequency range of transmitter from 30MHz to 10th harmonics was searched for spurious emissions from the device. The frequency range of weather band receiver from 30MHz to 2GHz was searched for spurious emissions from the device. Only those emissions reported were detected. All other emissions were at least 20 dB below the applicable limits.

For transmitter radiated spurious measurement, the spectrum analyzer resolution bandwidth was 10kHz for emissions below 1GHz, and 1MHz for emissions above 1GHz. Video bandwidth was 300kHz for emissions below 1GHz, and 3MHz for emissions above 1GHz. For receiver radiated spurious measurement, the spectrum analyzer resolution bandwidth was 100kHz for emission below 1GHz, and 1MHz for emissions above 1GHz. Video bandwidth was 3 times greater than resolution bandwidth.

All power-up methods were tested and the worst-case data were reported.

The following are all the test modes (only the worst-case was reported):

Tx without headset

Tx with headset

TEST REPORT

2.2 EUT Exercising Software

There was no special software to exercise the device. Once the PTT button was pushed, a signal was transmitted.

2.3 Special Accessories

No special accessory is needed for compliance of this device.

2.4 Measurement Uncertainty

When determining of the test conclusion, the Measurement Uncertainty of test has been considered. The values of the Measurement uncertainty for radiated emission test and RF conducted measurement test are $\pm 5.3\text{dB}$ and $\pm 1\text{dB}$ respectively.

Uncertainty and Compliance - Unless the standard specifically states that measured values are to be extended by the measurement uncertainty in determining compliance, all compliance determinations are based on the actual measured value.

2.5 Equipment Modification

No modifications by King Da Plastic Electronic Ltd. will be incorporated in each production model sold/leased in the United States.

2.6 Support Equipment

A headset with 1.2m unshielded cable.

The EUT has been tested in accordance with the standards identified in this test report. To the best of my knowledge and belief, these tests were performed using the measurement procedures described in this report. All instrumentations and accessories used to verify the EUT for compliance to the indicated standards are calibrated in accordance with ISO 17025:2005 requirements.

Testing was performed at Intertek Testing Services Hong Kong Ltd. Where meets the FCC listed site for certification application requirements stated in FCC Part 2 Section 2.948.

I attest that the necessary measurements were made under my supervision.

Attested by

*Intertek Testing Services Hong Kong Ltd.
Agent for King Da Plastic Electronic Ltd.*

TEST REPORT

EXHIBIT 3 RF POWER OUTPUT

3.0 RF Power Output (Section 2.1046(a), 95.639(a), 95.639(d))

Testing Procedure

1. On a test site, the EUT shall be placed at 0.8m height on a wooden turntable, and in the position closest to normal use as declared by the applicant.
2. The test antenna shall be oriented initially for vertical polarisation located 3m from EUT to correspond to the frequency of the transmitter.
3. The output of the test antenna shall be connected to the measuring receiver and the peak detector is used for the measurement.
4. The transmitter shall be switched on, if possible, without modulation and the measuring receiver shall be tuned to the frequency of the transmitter under test.
5. The test antenna shall be raised and lowered through the specified range of height until a maximum signal level is detected by the measuring receiver.
6. The transmitter shall then be rotated through 360° in the horizontal plane, until the maximum signal level is detected by the measuring receiver.
7. The test antenna shall be raised and lowered again through the specified range of height until a maximum signal level is detected by the measuring receiver.
8. The maximum signal level detected by the measuring receiver shall be noted.
9. The transmitter shall be replaced by a tuned dipole (substitution antenna).
10. The substitution antenna shall be orientated for vertical polarisation and the length of the substitution antenna shall be adjusted to correspond to the frequency of the transmitter.

TEST REPORT

Testing Procedure (Cont'd)

11. The substitution antenna shall be connected to a calibrated signal generator.
12. If necessary, the input attenuator setting of the measuring receiver shall be adjusted in order to increase the sensitivity of the measuring receiver.
13. The test antenna shall be raised and lowered through the specified range of height to ensure that the maximum signal is received.
14. The input signal to the substitution antenna shall be adjusted to the level that produces a level detected by the measuring receiver, that is equal to the level noted while the transmitter radiated power was measured, corrected for the change of input attenuator setting of the measuring receiver.
15. The input level to the substitution antenna shall be recorded as power level in dBm, corrected for any change of input attenuator setting of the measuring receiver.
16. The measurement shall be repeated with the test antenna and the substitution antenna orientated for horizontal polarisation.
17. The measure of the effective radiated power is the larger of the two levels recorded, at the input to the substitution antenna, corrected for gain of the substitution antenna if necessary.

TEST REPORT

TRANSMISSION POWER

Table 1

Channel	Frequency (MHz)	Effective Radiated Power		FCC 95.639 Limit (W)	Margin (W)
		(dBm)	(W)		
1	462.5625	3.2	0.002	0.500	-0.498
2	462.5875	3.2	0.002	0.500	-0.498
3	462.6125	3.2	0.002	0.500	-0.498
4	462.6375	3.2	0.002	0.500	-0.498
5	462.6625	3.2	0.002	0.500	-0.498
6	462.6875	3.2	0.002	0.500	-0.498
7	462.7125	3.2	0.002	0.500	-0.498

Notes:

- 1) Negative sign in the margin column shows the value below limits.
- 2) Data shown above is for FRS.

Verdict: Pass

Test Engineer: Koo Wai Ip

Date of Test: April 18, 2017

TEST REPORT

EXHIBIT 4 MODULATION CHARACTERISTICS

4.0 Modulation Characteristics (Section 2.1047(a)(b), 95.637(a))

In order to satisfy the 95.637(a) and 2.1047(b) requirements, Modulation Frequency Response and Modulation Limiting Characteristics are attached in Exhibit 4.1 & 4.2.

In order to satisfy the 2.1047(a) requirement, Audio Low Pass Filter Response is attached in Exhibit 4.3.

The modulation frequency response curve and modulation limiting characteristic curve are saving in following page.

The audio low pass frequency response curve is saving in following page.

TEST REPORT

4.1 Modulation Frequency Response (Section 2.1047(a), 95.637(a))

Testing Procedure

1) Set-up the test equipment in the following configuration:

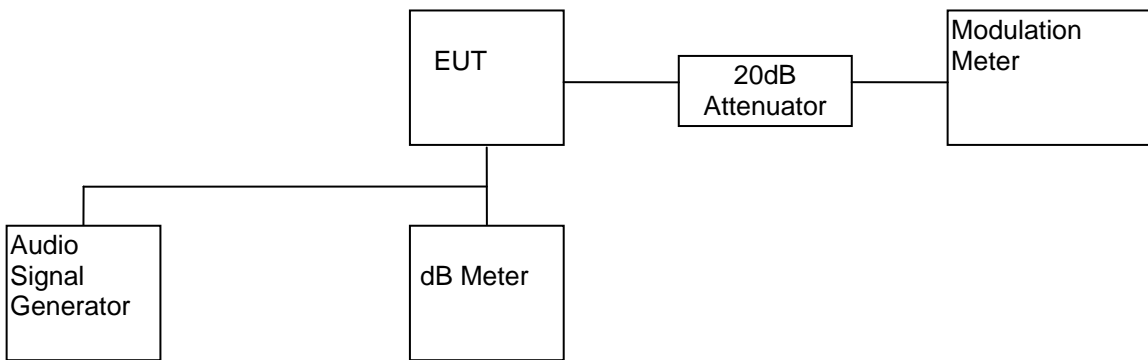

- 2) Set the audio signal generator frequency to the sound pressure level 127.0dB SPL at the microphone of the EUT.
- 3) The frequency of the audio signal generator is changed from 100Hz to 5kHz.
- 4) Record the frequency deviation.
- 5) The peak frequency deviation must not exceed:

FRS: $\pm 2.5\text{kHz}$

6) Calculate the audio frequency response at each frequency as:

$$\text{response} = 20 \log_{10}(\text{DEV}_{\text{FREQ}} / \text{DEV}_{\text{REF}});$$

DEV_{REF} = Frequency deviation at 1000Hz ;

DEV_{FREQ} = Frequency deviation at 100 - 5000Hz ;

7) From the plot, audio frequency response rolls off before 2.250kHz.

TEST REPORT

MODULATION FREQUENCY RESPONSE

Test Result

Table 2

Test Channel: 4

Input level = 127dB SPL

Modulation Frequency(Hz)	Frequency Deviation(kHz)	Audio Frequency Response (dB)
100	0.085	-27.92
200	0.151	-22.93
300	0.921	-7.22
400	1.035	-6.21
500	1.831	-1.25
600	2.036	-0.33
700	2.180	0.26
800	2.159	0.18
900	2.205	0.36
1000	2.115	0.00
1250	2.360	0.95
1500	2.334	0.86
1750	2.330	0.84
2000	2.340	0.88
2250	2.381	1.03
2500	2.367	0.98
2750	2.119	0.02
3000	1.881	-1.02
3125	0.864	-7.78
3250	0.068	-29.86
3500	0.079	-28.55
4000	0.065	-30.25
5000	0.108	-25.84

Verdict: Pass

Test Engineer: Koo Wai Ip

Date of Test: April 18, 2017

TEST REPORT

INTERTEK TESTING SERVICES

Modulation Frequency Response

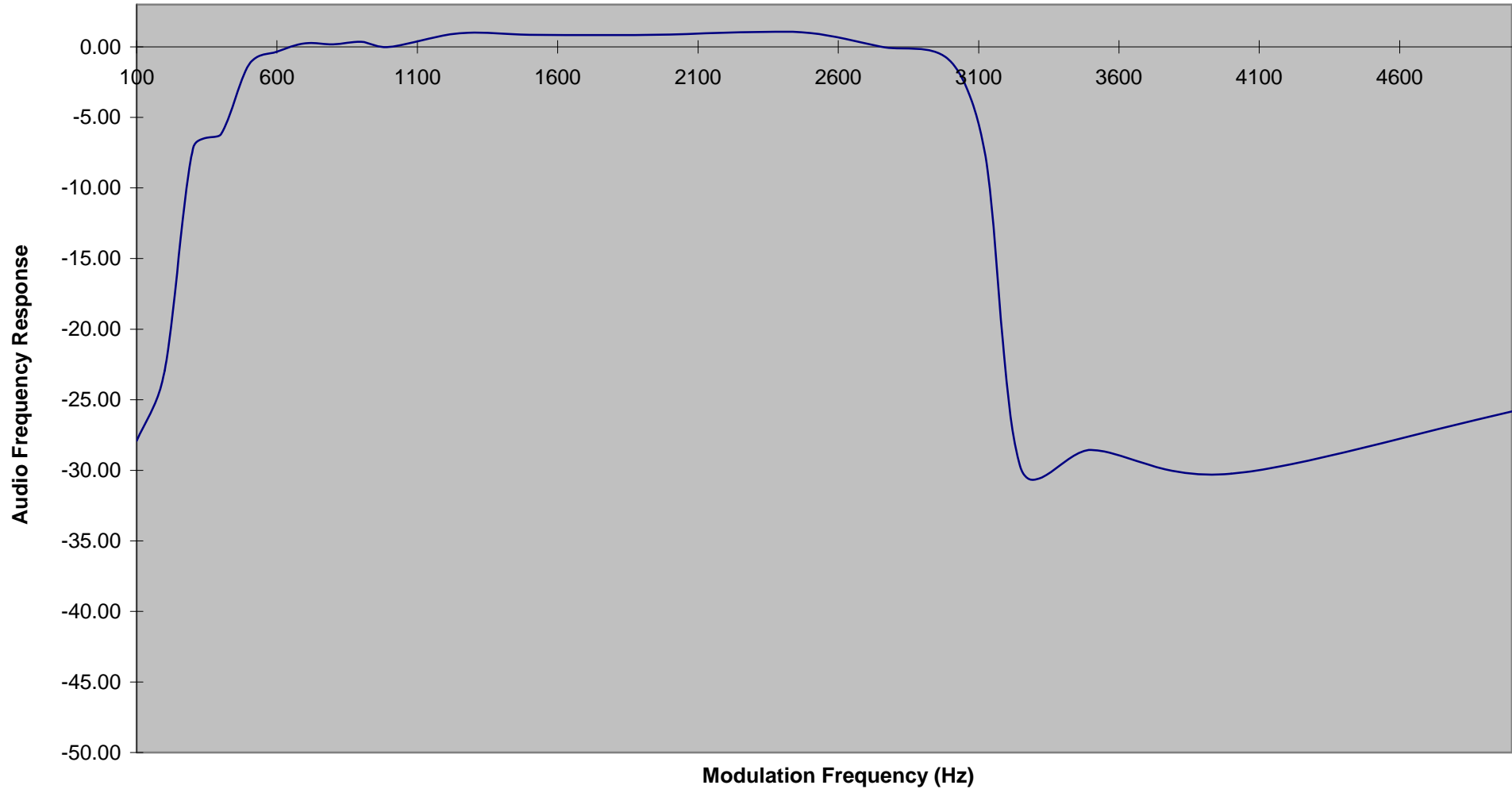

FCC ID: SF8KDWT2017

Modulation Frequency (Hz)

mfr - 1 of 1

TEST REPORT

4.2 Modulation Limiting Characteristics (Section 2.1047(b), 95.637(a))

Testing Procedure

- 1) Set-up the test equipment in the following configuration:

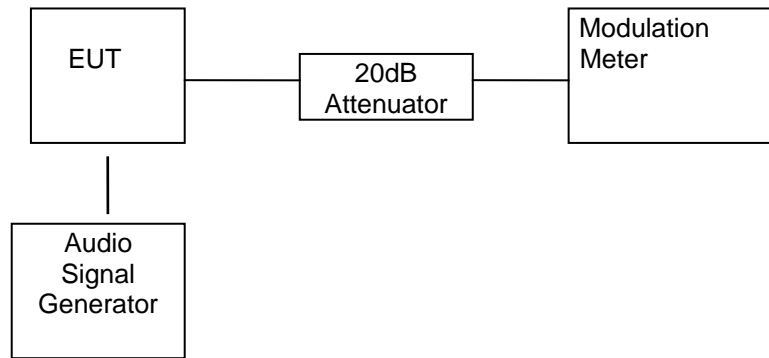

- 2) Set the frequency of the audio signal generator to 500Hz and adjust the level from 47dB SPL to 137dB SPL.
- 3) Record the maximum value of plus or minus peak frequency deviation.
- 4) Repeat the above procedure with frequency 1000Hz, 2500Hz & 3125Hz.
- 5) The peak frequency deviation must not exceed:

FRS : ±2.5kHz

TEST REPORT

MODULATION LIMITING CHARACTERISTICS

Test Result

Table 3

Test Channel: 4

Modulation Input (dBSPL)	Peak Frequency Deviation (kHz) at 500Hz	Peak Frequency Deviation (kHz) at 1000Hz	Peak Frequency Deviation (kHz) at 2500Hz	Peak Frequency Deviation (kHz) at 3125Hz
47	0.065	0.065	0.065	0.065
57	0.065	0.063	0.065	0.065
67	0.065	0.065	0.065	0.065
77	0.065	0.071	0.085	0.065
87	0.065	0.108	0.186	0.065
97	0.065	0.598	0.937	0.168
107	0.081	1.674	2.168	0.554
117	1.041	1.861	2.262	1.154
127	1.831	2.115	2.367	0.864

Verdict: Pass

Test Engineer: Koo Wai Ip

Date of Test: April 18, 2017

TEST REPORT

INTERTEK TESTING SERVICES

Modulation Limiting Characteristic

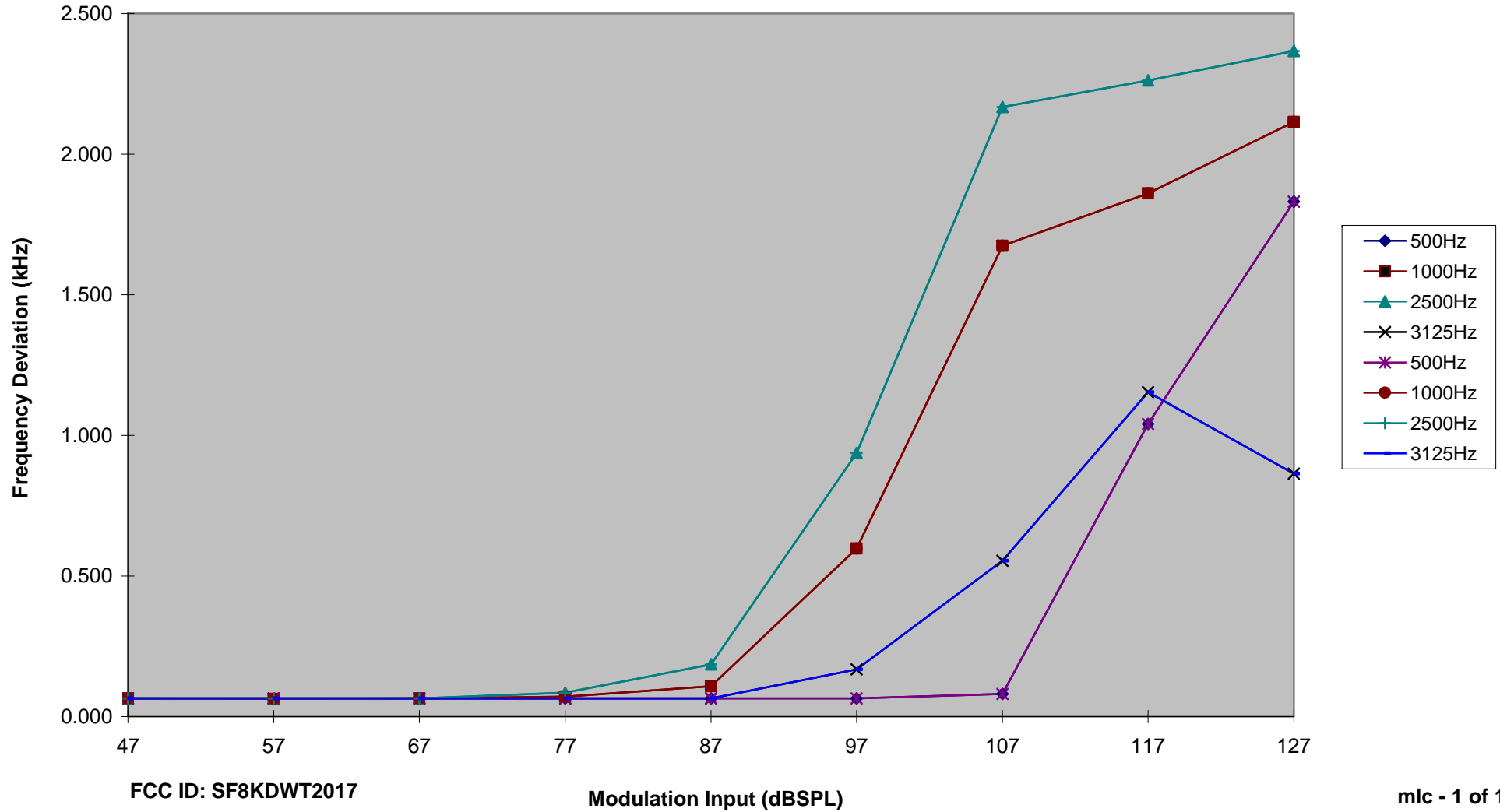

TEST REPORT

4.3 Audio Low Pass Filter Response (Section 2.1047(a), 95.637(b))

Testing Procedure

- 1) Connect the audio signal generator to the input of the post limiter low pass filter and the dB meter to the output of the post limiter low pass filter.
- 2) Apply a 1000 Hz tone from the audio signal generator and adjust the level per manufacturer's specifications. Record the dB level of the 1000 Hz tone as LEV_{REF} .
- 3) Set the audio signal generator to the desired test frequency between 3000 Hz and the upper low pass filter limit. Record the dB level at the test frequency as LEV_{FREQ} .
- 4) Calculate the audio frequency response at the test frequency as:

$$\text{low pass filter response} = LEV_{FREQ} - LEV_{REF}$$

- 5) Repeat the above procedure for all the desired test frequencies.

TEST REPORT

LOW-PASS FILTER RESPONSE

Test Result

Table 4

Test Channel: 4

Audio Input Strength = 2000mVrms

Frequency (kHz)	dB relative to 1 kHz	Part 95.637(b)
1	0.0	0.0
3	-30.0	0.0
4	-52.0	-7.5
5	-52.0	-13.3
6	-52.0	-18.1
8	-52.0	-25.6
10	-52.0	-31.4
15	-52.0	-41.9
20	-52.0	-50.0
30	-52.0	-50.0
40	-52.0	-50.0
50	-52.0	-50.0
60	-52.0	-50.0
70	-52.0	-50.0
80	-52.0	-50.0
90	-52.0	-50.0
100	-52.0	-50.0

Audio Output at 1kHz: 0.0dBV

Verdict: Pass

Test Engineer: Koo Wai Ip

Date of Test: April 18, 2017

TEST REPORT

INTERTEK TESTING SERVICES

Audio Low Pass Filter Response

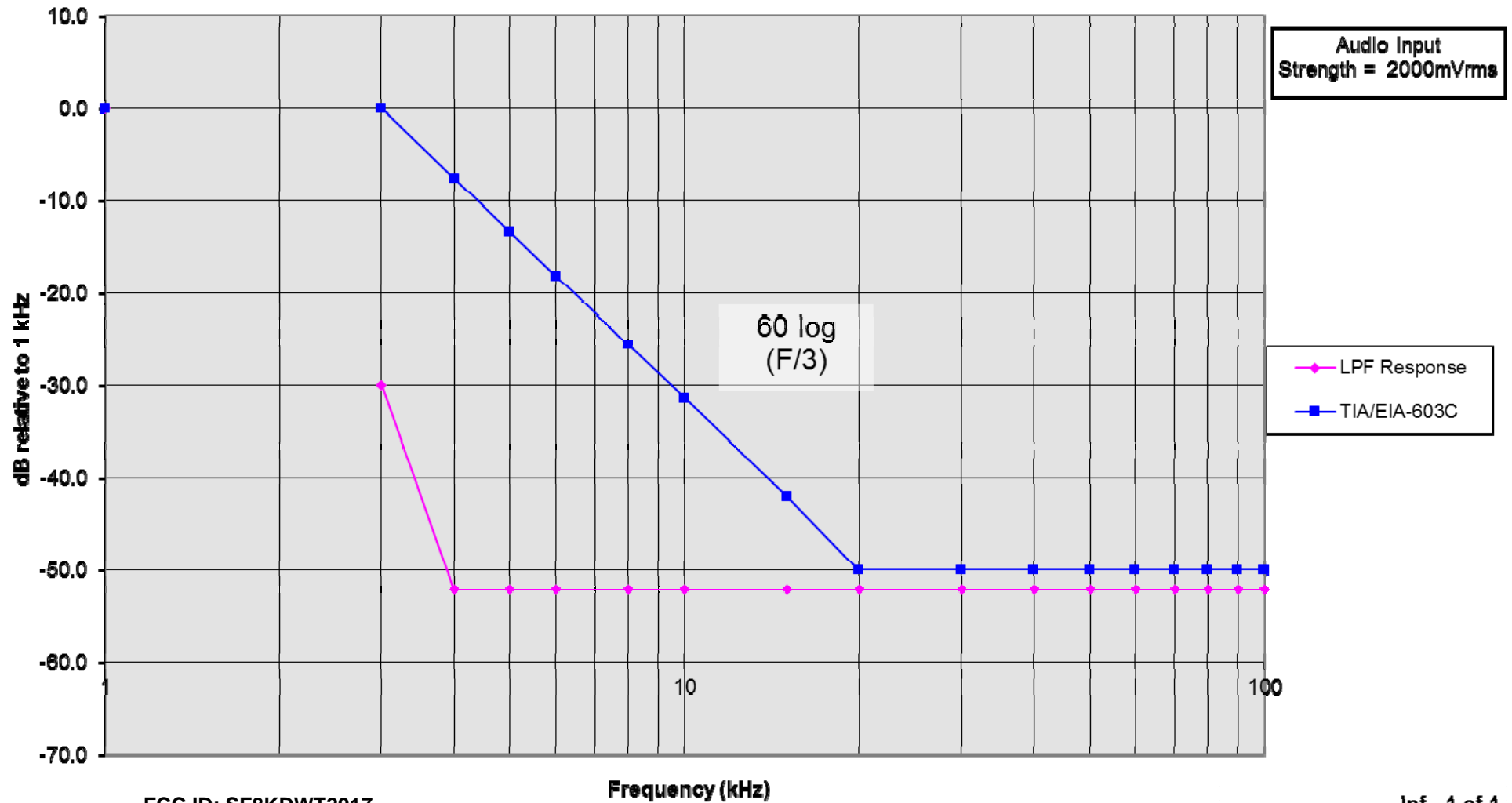

TEST REPORT

EXHIBIT 5 OCCUPIED BANDWIDTH

5.0 Occupied Bandwidth (Section 2.1049, 95.633(c))

Testing Procedure

1) Set-up the test equipment in the following configuration:

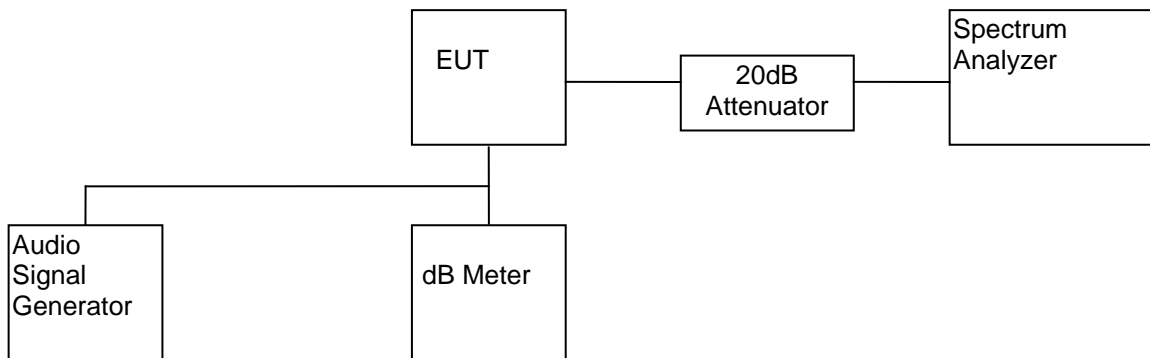

- 2) Set the level of audio signal generator to obtain 16 dB greater than required for 50% modulation.
- 3) The occupied bandwidth is measured with the spectrum analyzer set at 2kHz/div scan and 10dB/div.

TEST REPORT

Test Result

Table 5

System	Channel	Measured Bandwidth (kHz)	Limit (kHz)
FRS	4	5.60	≤20

Verdict: Pass

The bandwidth plot is saving in following page.

Test Engineer: Koo Wai Ip

Date of Test: April 18, 2017

TEST REPORT

OCCUPIED BANDWIDTH PLOTS

Plot CH4

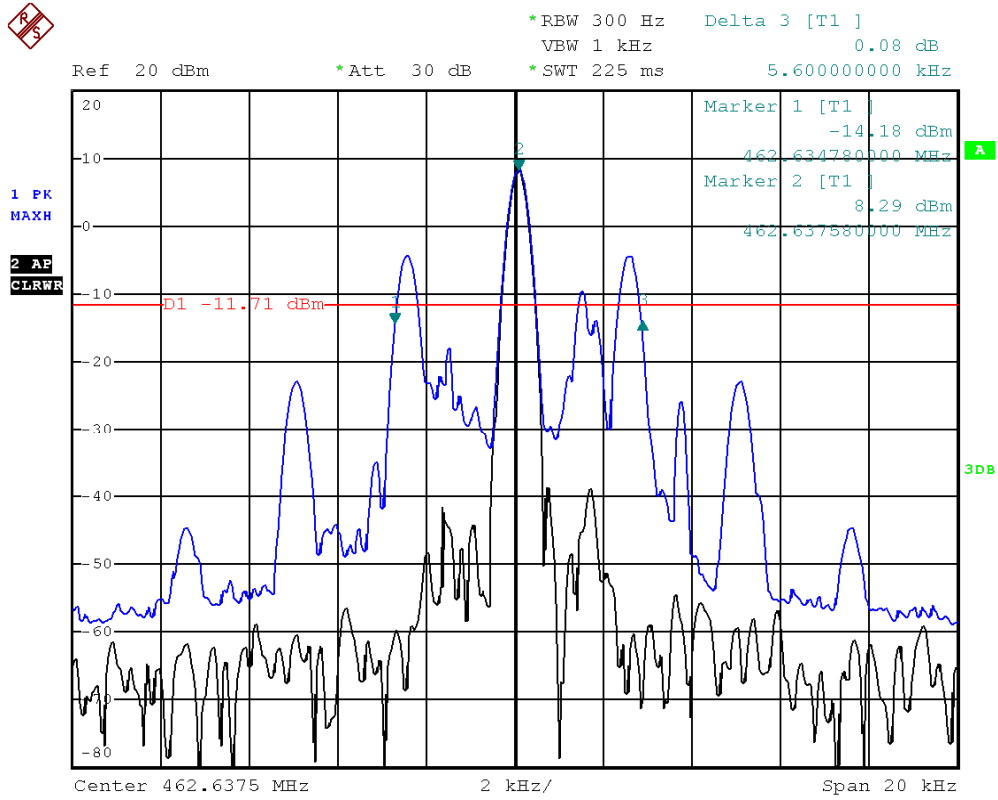

TEST REPORT

EXHIBIT 6 SPURIOUS EMISSION

6.0 Spurious Emission

In order to satisfy the 95.635(b) requirement, the spurious emission from the EUT are measured and shown in the Exhibit 6.1.

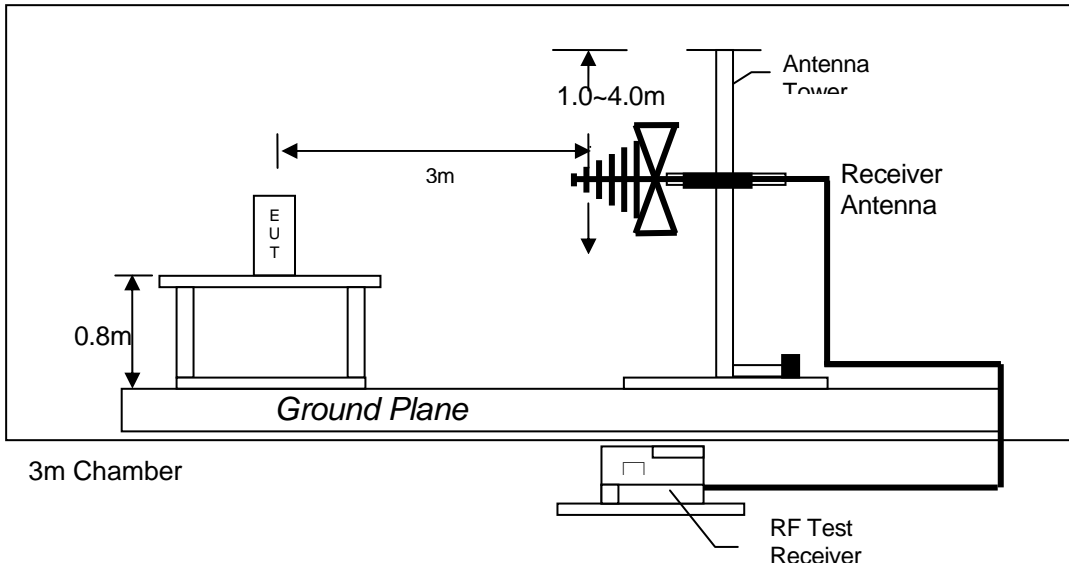

Test setup of radiated emissions up to 1GHz

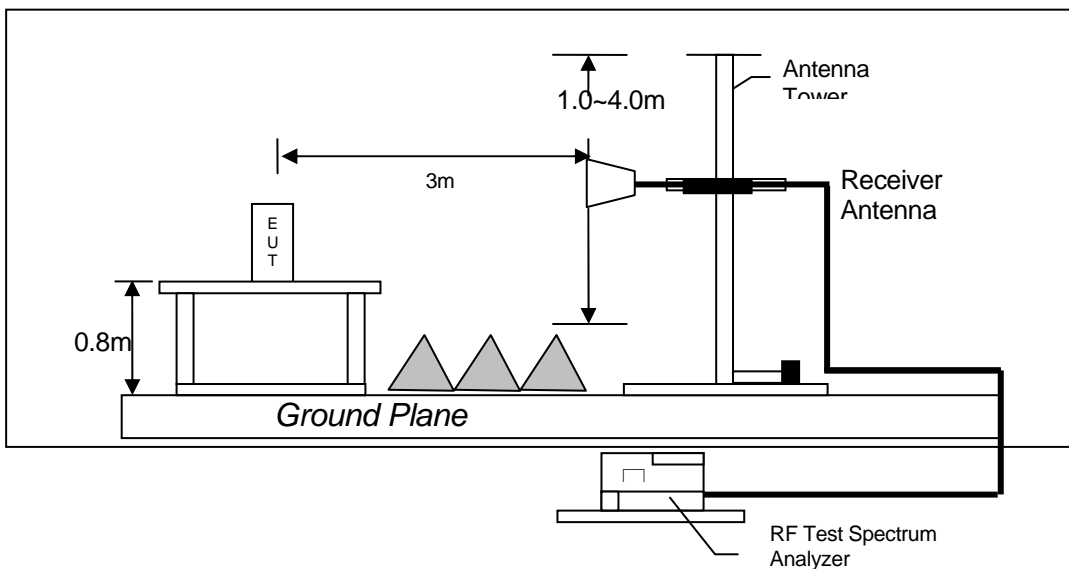

Test setup of radiated emissions above 1GHz

TEST REPORT

6.1 Power of Spurious Radiation (Section 2.1053, 95.635(b))

Testing Procedure

Radiated emission measurements were performed according to the procedures in ANSI/TIA-603-C-2004. All measurements were performed at Workshop No. 3, G/F., World-Wide Industrial Centre, 43-47 Shan Mei Street, Fo Tan, Sha Tin, N.T., Hong Kong

TEST REPORT

Test Result

Table 6(a)

1) Unwanted emission from CARRIER $\pm 6.25\text{kHz}$ to CARRIER $\pm 31.25\text{kHz}$

REGION	UNWANTED EMISSION CHANNEL 4
CARRIER $\pm 6.25\text{kHz}$ to $\pm 12.5\text{kHz}$	<25dB
CARRIER $\pm 12.5\text{kHz}$ to $\pm 31.25\text{kHz}$	<35dB

TEST REPORT

SPURIOUS EMISSION PLOTS

Plot CH4

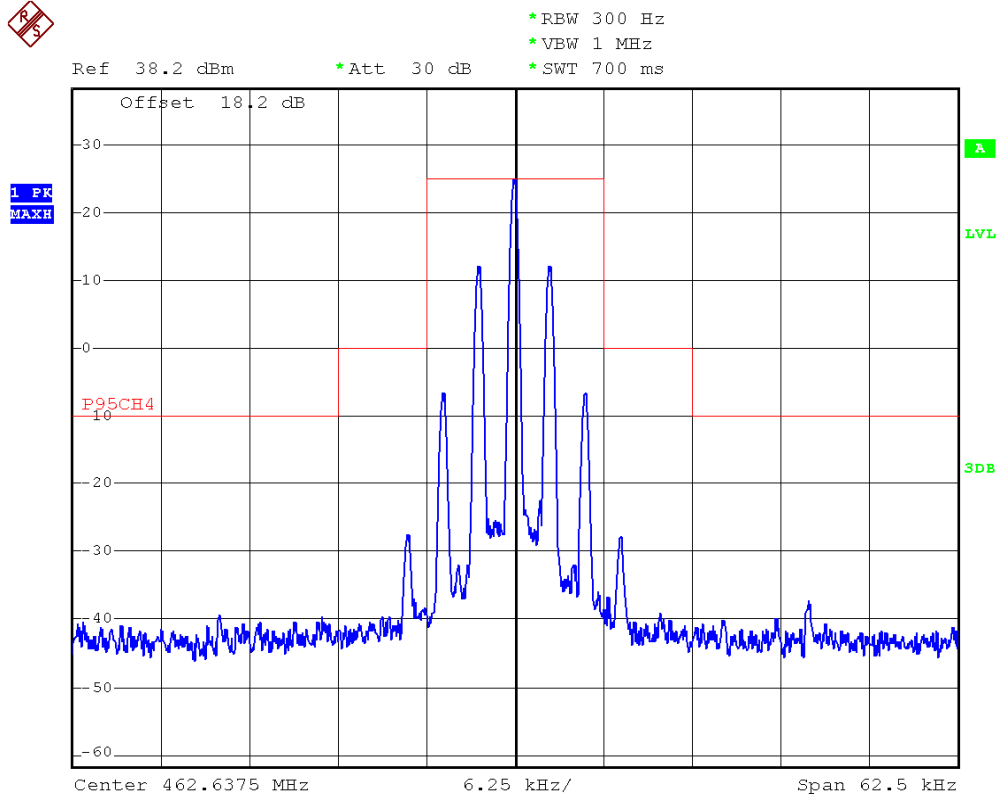

TEST REPORT

Test Result

Table 6(b): Channel 4 With Earphone

Frequency (MHz)	Effective Radiated Power (dBm)	Transmission Power (dBm)	Attenuation (dBc)	Limit (dBc)	Margin (dB)
925.273	-55.00	3.20	58.20	16.20	-42.00
1387.940	-39.86	3.20	43.06	16.20	-26.86
1850.670	-46.88	3.20	50.08	16.20	-33.88
2313.150	-42.94	3.20	46.14	16.20	-29.94
2775.670	-45.96	3.20	49.16	16.20	-32.96
3238.510	-37.85	3.20	41.05	16.20	-24.85
3701.190	-40.75	3.20	43.95	16.20	-27.75
4163.770	-23.50	3.20	26.70	16.20	-10.50
4626.420	-33.25	3.20	36.45	16.20	-20.25

- Remark:
1. Transmission power is 3.2 dBm or -26.8 dB(W).
 2. According to Section 95.635(b7), the unwanted emission should be attenuated below TP by at least $43 + 10 \log_{10}(TP)$ dB or 16.2 dB.
 3. The test is performed according to ANSI/TIA-603-C-2004.
 4. For emission <1000MHz, RBW = 100kHz, VBW \geq RBW
For emission >1000MHz, RBW = 1MHz, VBW \geq RBW

Verdict: Pass

Test Engineer: Koo Wai Ip

Date of Test: April 18, 2017

TEST REPORT

EXHIBIT 7 FREQUENCY STABILITY

7.0 Frequency Stability (Section 2.1055(a)(b)(d), 95.626(b) for FRS)

The frequency tolerance was tested in normal condition & over extreme ambient conditions with respect to voltage and temperature variation.

7.1 Frequency Tolerance (Section 95.626(b) for FRS)

Testing Procedure

- 1) Set-up the test equipment in the following configuration:

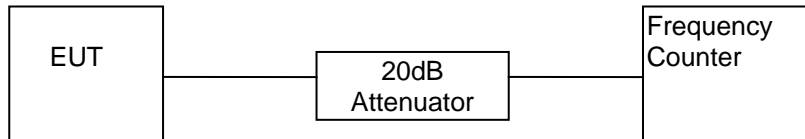

- 2) Measure all transmit channel frequencies in MHz.

TEST REPORT

FREQUENCY TOLERANCE

Test Result

Table 7

Channel	Frequency (MHz)	Measured Frequency (MHz)	Frequency Tolerance (%)
1	462.5625	462.56246	-0.000009
2	462.5875	462.58752	0.000004
3	462.6125	462.61249	-0.000002
4	462.6375	462.63748	-0.000004
5	462.6625	462.66248	-0.000004
6	462.6875	462.68747	-0.000006
7	462.7125	462.71247	-0.000006

FCC Limit for FRS (95.626(b)): $\leq \pm 0.00025\%$

Verdict: Passed

Test Engineer: Koo Wai Ip

Date of Test: April 18, 2017

TEST REPORT

7.2 Frequency Stability - Temperature (Section 2.1055(a)(b), 95.626(b) for FRS)

Testing Procedure

- 1) Set-up the test equipment in the following configuration:

Temperature Chamber

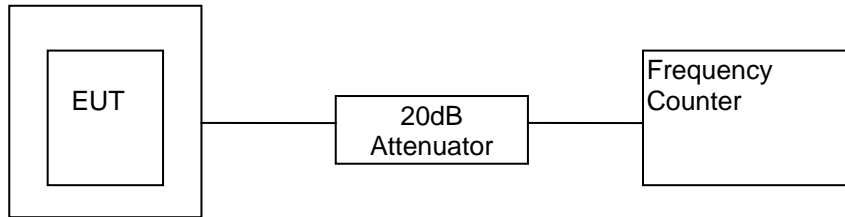

- 2) Set the Temperature Chamber to 20°C and stabilize the EUT temperature for one hour. Set transmitter ON for two minutes.
- 3) Measure the channel frequency of channel 4 in MHz.
- 4) Turn the EUT OFF.
- 5) Repeat the above procedure from -20°C to 50°C with 10°C increment for FRS.

TEST REPORT

FREQUENCY TOLERANCE WITH TEMPERATURE VARIATION

Test Result

Table 8(a)

Channel: 4

Temperature (°C)	Frequency (MHz)	Measured Frequency (MHz)	Frequency Deviation (%)	Frequency Tolerance w.r.t +20°C (ppm)
-20	462.63750	462.63655	-0.000205	-2.0
-10	462.63750	462.63693	-0.000123	-1.2
0	462.63750	462.63798	0.000104	1.1
10	462.63750	462.63798	0.000104	1.1
20	462.63750	462.63748	-0.000004	0.0
30	462.63750	462.63796	0.000099	1.0
40	462.63750	462.63789	0.000084	0.9
50	462.63750	462.63794	0.000095	1.0

Remark: 1) For FRS, frequency tolerance must be maintained within a frequency tolerance of 0.00025%.

Verdict: Passed

Test Engineer: Koo Wai Ip

Date of Test: April 18, 2017

TEST REPORT

7.3 Frequency Stability - Voltage (Section 2.1055(d), 95.626(b) for FRS)

Testing Procedure

- 1) Set-up the test equipment in the following configuration:

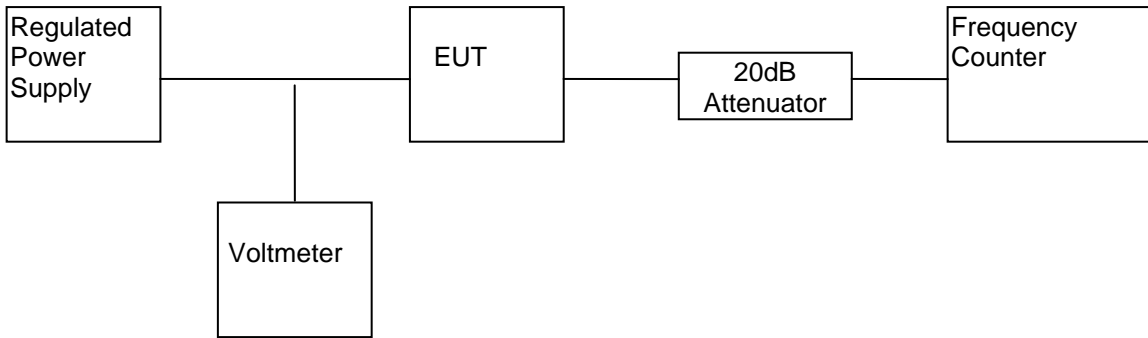

- 2) Vary the level of regulated power supply to the manufacturer specified battery end point of the EUT.
- 3) Measure the channel frequency of channel 4 in MHz.

TEST REPORT

FREQUENCY DEVIATION WITH VOLTAGE VARIATION

Test Result

Table 9

The manufacturer specified battery end point 2.2V

Channel	Frequency (MHz)	Measured Frequency (MHz)	Frequency Tolerance (%)
4	462.63750	462.63787	0.000080

- Remark: 1) For FRS, frequency tolerance must be maintained within a frequency tolerance of 0.00025%.
2) The test voltage is from primary supply voltage to 2.2V

Test Engineer: Koo Wai Ip

Date of Test: April 18, 2017

TEST REPORT

EXHIBIT 8 EQUIPMENT LIST

8.0 Equipment List

1) Radiated Emissions Test

EQUIPMENT	Semi-anechoic Chamber	Test Receiver	Bi-conical Antenna
Registration No.	EMC209	EMC567	EMC576
Manufacturer	Frankonia	R & S	R & S
Calibration Date	Apr. 25, 2017	Jul. 11, 2017	Sep. 01, 2015
Calibration Due Date	Apr. 25, 2018	Jul. 11, 2018	Sep. 01, 2017

EQUIPMENT	Log Periodic Antenna	Coaxial cable	Microwave amplifier 0.5-26.5GHz, 25dB gain
Registration No.	EMC039	EMC624	EMC557
Manufacturer	R&S	Harbour	HP
Calibration Date	Sep. 01, 2015	Jun. 10, 2016	Jul. 18, 2016
Calibration Due Date	Sep. 01, 2017	Jun. 10, 2018	Jul. 18, 2018

EQUIPMENT	Horn Antenna
Registration No.	EMC597
Manufacturer	EMCO
Calibration Date	Aug. 26, 2015
Calibration Due Date	Aug. 26, 2017

2) Conducted Emissions Test

EQUIPMENT	EMI Test Receiver	LISN	Pulse Limiter
Registration No.	EW-2666	EW-0192	EW-3248
Manufacturer	R&S	R&S	R&S
Model No.	ESC17	ESH3-Z5	ESH3-Z2
Calibration Date	Jun. 17, 2016	Aug. 26, 2016	Oct. 12, 2016
Calibration Due Date	Jun. 17, 2017	Aug. 26, 2017	Oct. 12, 2017

3) Modulation Characteristics

EQUIPMENT	Communication Service Monitor	Temperature & Humidity Chamber
Registration No.	EW-1775	EW-2134
Manufacturer	R&S	GIANT FORCE
Model No.	CMS54	GTH-750-40-CP-SD
Calibration Date	Nov. 18, 2016	Sep. 26, 2016
Calibration Due Date	Nov. 18, 2017	Sep. 4, 2017