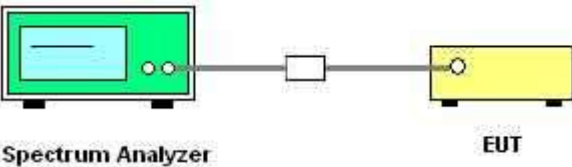

## 6.7. Dwell Time

### 6.7.1. Test Specification

<b>Test Requirement:</b>	FCC Part15 C Section 15.247 (a)(1)
<b>Test Method:</b>	ANSI C63.4:2009 and DA00-705
<b>Limit:</b>	The average time of occupancy on any channel shall not be greater than 0.4 seconds within a period of 0.4 seconds multiplied by the number of hopping channels employed.
<b>Test Setup:</b>	 <p style="text-align: center;">Spectrum Analyzer                      EUT</p>
<b>Test Mode:</b>	Hopping mode
<b>Test Procedure:</b>	<ol style="list-style-type: none"> <li>1. The testing follows FCC Public Notice DA 00-705 Measurement Guidelines.</li> <li>2. The RF output of EUT was connected to the spectrum analyzer by RF cable and attenuator. The path loss was compensated to the results for each measurement.</li> <li>3. Set to the maximum power setting and enable the EUT transmit continuously.</li> <li>4. Enable the EUT hopping function.</li> <li>5. Use the following spectrum analyzer settings: Span = zero span, centered on a hopping channel; RBW = 1 MHz; VBW<math>\geq</math>RBW; Sweep = as necessary to capture the entire dwell time per hopping channel; Detector function = peak; Trace = max hold.</li> <li>6. Measure and record the results in the test report.</li> </ol>
<b>Test Result:</b>	PASS

### 6.7.2. Test Instruments

RF Test Room				
Equipment	Manufacturer	Model	Serial Number	Calibration Due
Spectrum Analyzer	Agilent	N9020A	MY49100060	Oct. 21, 2015
RF cable	TCT	RE-06	N/A	Sep.15 , 2015
Antenna Connector	TCT	RFC-01	N/A	Sep.15 , 2015

**Note:** The calibration interval of the above test instruments is 12 months and the calibrations are traceable to international system unit (SI).

**6.7.3. Test Data**

Mode	Packet	Hops Over Occupancy Time (hops)	Package Transfer Time (ms)	Dwell time (second)	Limit (second)	Result
GFSK	DH5	106.67	2.958	0.316	0.4	PASS
Pi/4 DQPSK	2-DH5	106.67	2.953	0.315	0.4	PASS
8DPSK	3-DH5	106.67	2.953	0.315	0.4	PASS

**Note:** 1. In normal mode, hopping rate is 1600 hops/s with 6 slots in 79 hopping channels.

With channel hopping rate (1600 / 6 / 79) in Occupancy Time Limit (0.4 x 79) (s), Hops Over Occupancy Time comes to (1600 / 6 / 79) x (0.4 x 79) = 106.67 hops

2. Dwell Time(s) = Hops Over Occupancy Time (hops) x Package Transfer Time

**Test plots as follows:**

GFSK

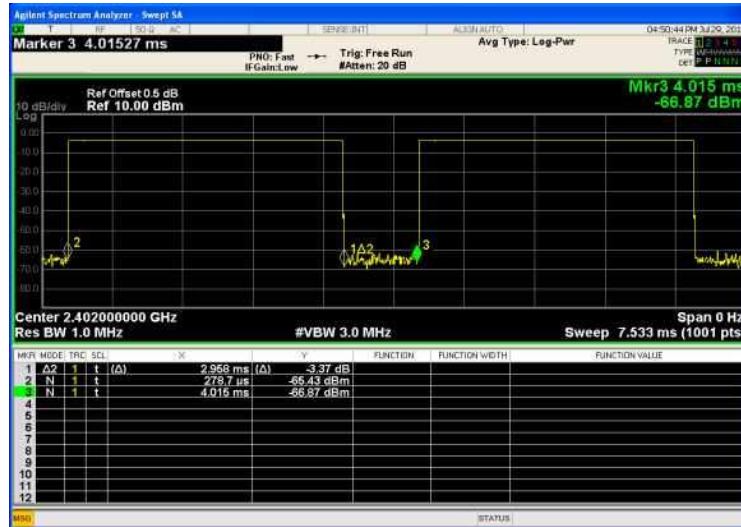

Pi/4DQPSK



8DPSK

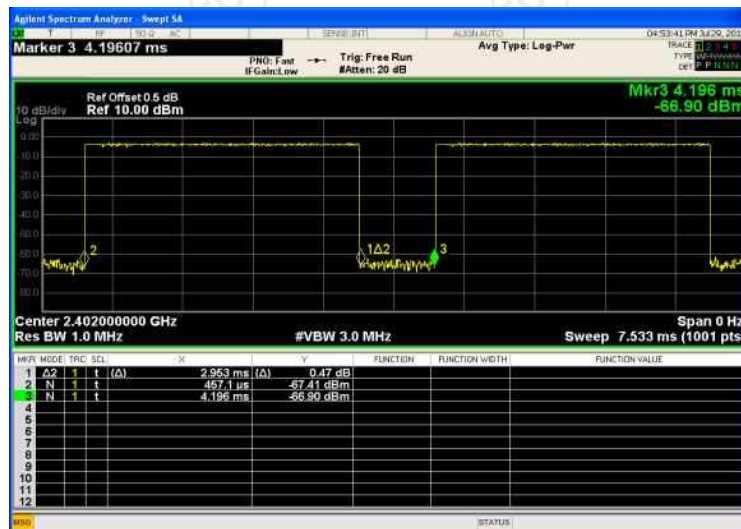

### 6.8. Pseudorandom Frequency Hopping Sequence

**Test Requirement:** FCC Part15 C Section 15.247 (a)(1) requirement:

Frequency hopping systems shall have hopping channel carrier frequencies separated by a minimum of 25 kHz or the 20 dB bandwidth of the hopping channel, whichever is greater.

Alternatively, Frequency hopping systems operating in the 2400-2483.5 MHz band may have hopping channel carrier frequencies that are separated by 25 kHz or two-thirds of the 20 dB bandwidth of the hopping channel, whichever is greater, provided the systems operate with an output power no greater than 125 mW. The system shall hop to channel frequencies that are selected at the system hopping rate from a Pseudorandom ordered list of hopping frequencies. Each frequency must be used equally on the average by each transmitter. The system receivers shall have input bandwidths that match the hopping channel bandwidths of their corresponding transmitters and shall shift frequencies in synchronization with the transmitted signals.

#### EUT Pseudorandom Frequency Hopping Sequence

The pseudorandom sequence may be generated in a nine-stage shift register whose 5th and 9th stage outputs are added in a modulo-two addition stage. And the result is fed back to the input of the first stage. The sequence begins with the first one of 9 consecutive ones; i.e. the shift register is initialized with nine ones.

- Number of shift register stages: 9
- Length of pseudo-random sequence:  $2^9 - 1 = 511$  bits
- Longest sequence of zeros: 8 (non-inverted signal)

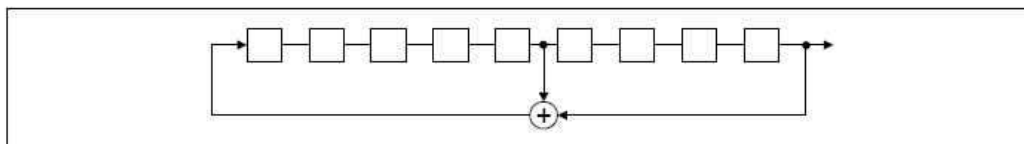

Linear Feedback Shift Register for Generation of the PRBS sequence

An example of Pseudorandom Frequency Hopping Sequence as follow:

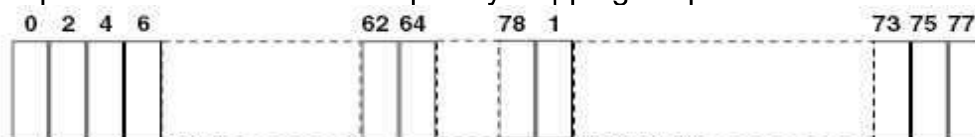

Each frequency used equally on the average by each transmitter. The system receivers have input bandwidths that match the hopping channel bandwidths of their corresponding transmitters and shift frequencies in synchronization with the transmitted signals.

## 6.9. Conducted Band Edge Measurement

### 6.9.1. Test Specification

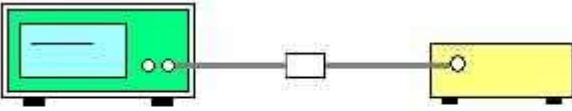
<b>Test Requirement:</b>	FCC Part15 C Section 15.247 (d)
<b>Test Method:</b>	ANSI C63.4:2009 and DA00-705
<b>Limit:</b>	In any 100 kHz bandwidth outside the intentional radiation frequency band, the radio frequency power shall be at least 20 dB below the highest level of the radiated power. In addition, radiated emissions which fall in the restricted bands must also comply with the radiated emission limits.
<b>Test Setup:</b>	 <p style="text-align: center;">Spectrum Analyzer                      EUT</p>
<b>Test Mode:</b>	Transmitting mode with modulation
<b>Test Procedure:</b>	<ol style="list-style-type: none"> <li>1. The testing follows the guidelines in Band-edge Compliance of RF Conducted Emissions of FCC Public Notice DA 00-705 Measurement Guidelines.</li> <li>2. Set to the maximum power setting and enable the EUT transmit continuously.</li> <li>3. Set RBW = 100 kHz (<math>\geq 1\%</math> span=10MHz), VBW = 300 kHz (<math>\geq</math>RBW). Band edge emissions must be at least 20 dB down from the highest emission level within the authorized band as measured with a 100kHz RBW. The attenuation shall be 30 dB instead of 20 dB when RMS conducted output power procedure is used.</li> <li>4. Enable hopping function of the EUT and then repeat step 2 and 3.</li> <li>5. Measure and record the results in the test report.</li> </ol>
<b>Test Result:</b>	PASS

### 6.9.2. Test Instruments

RF Test Room				
Equipment	Manufacturer	Model	Serial Number	Calibration Due
Spectrum Analyzer	Agilent	N9020A	MY49100060	Oct. 21, 2015
RF cable	TCT	RE-06	N/A	Sep.15 , 2015
Antenna Connector	TCT	RFC-01	N/A	Sep.15 , 2015

**Note:** The calibration interval of the above test instruments is 12 months and the calibrations are traceable to international system unit (SI).

### 6.9.3. Test Data

#### GFSK Modulation

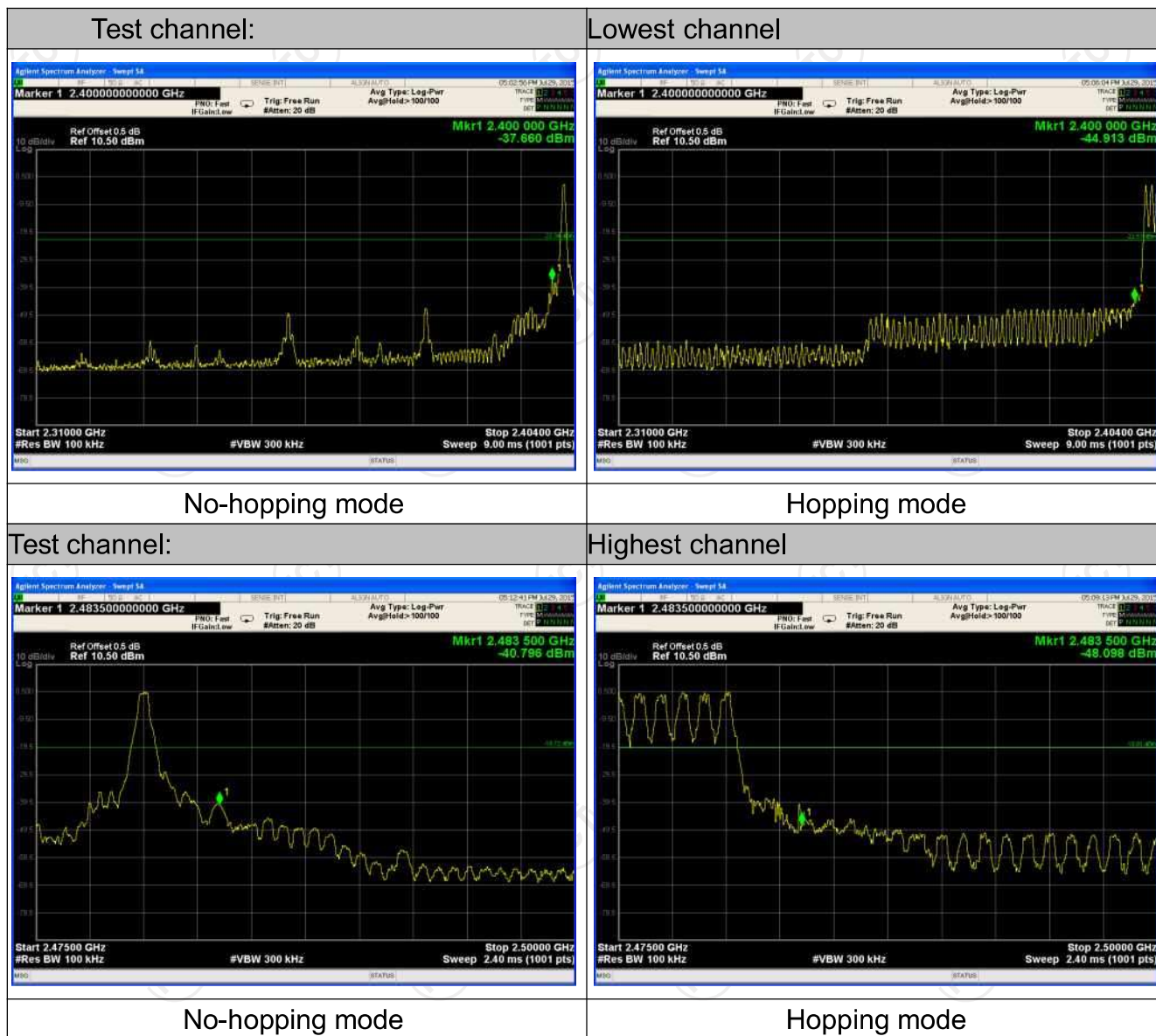

**Pi/4DQPSK Modulation**

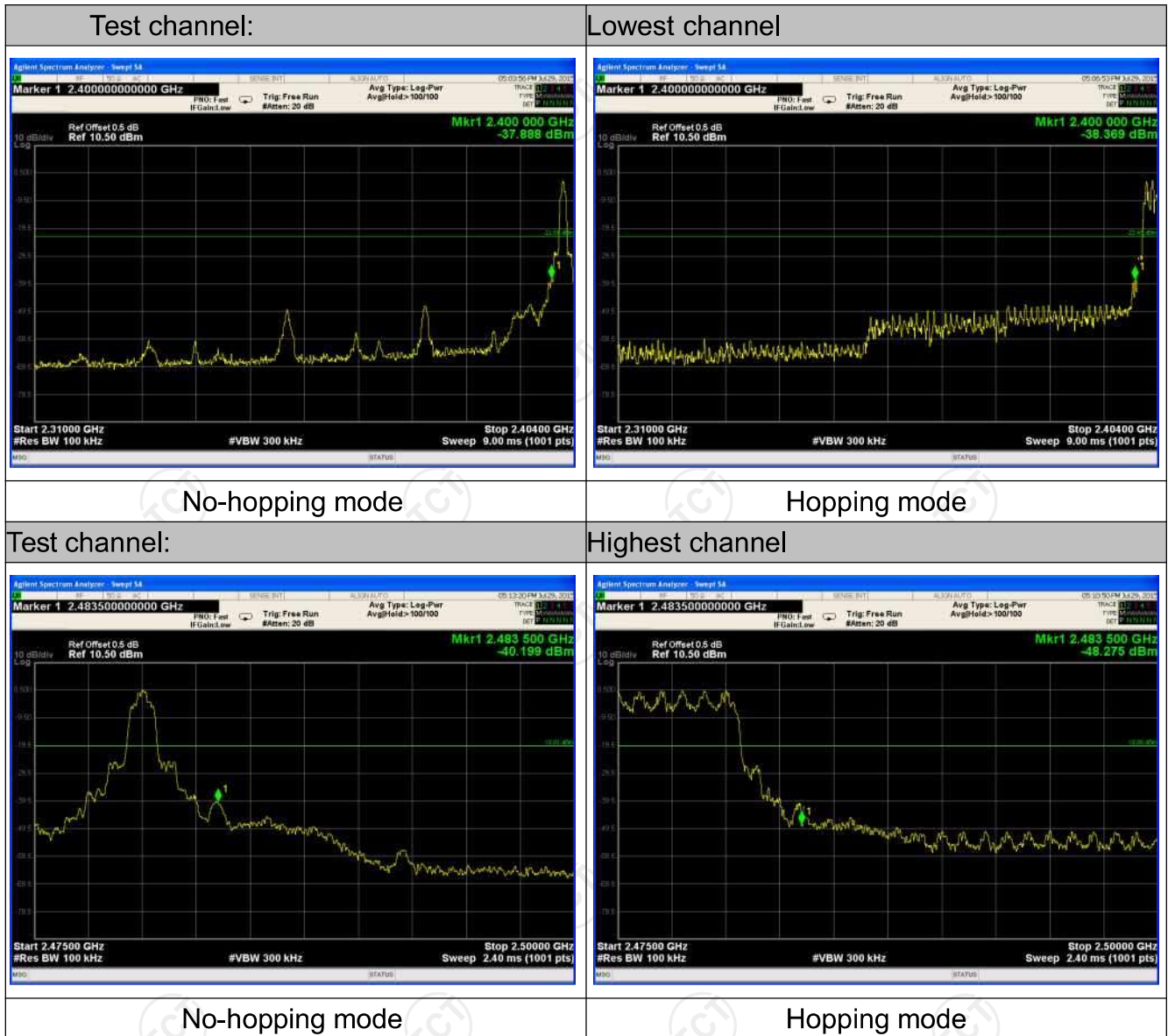

## 8DPSK Modulation

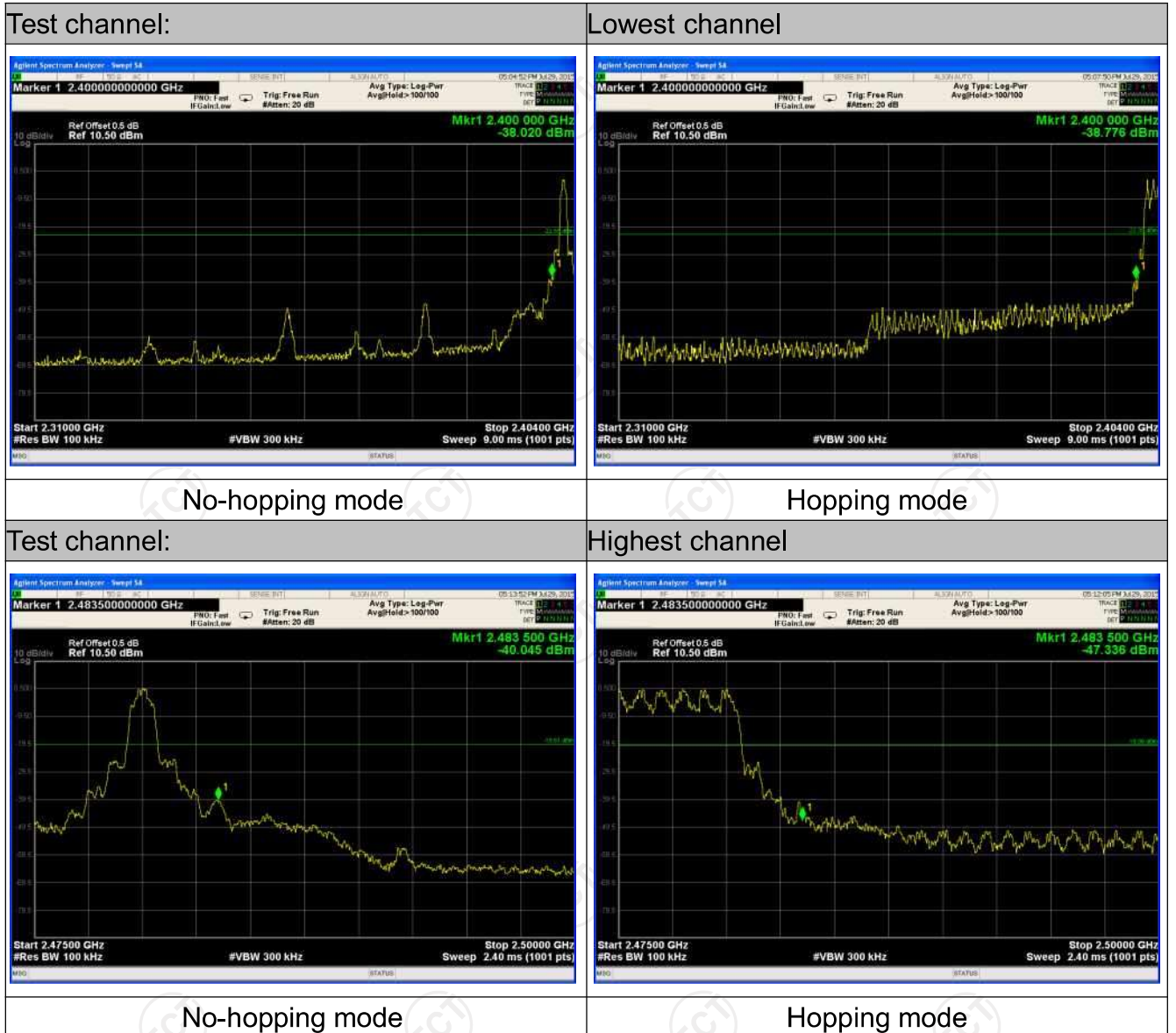



## 6.10. Conducted Spurious Emission Measurement

### 6.10.1. Test Specification

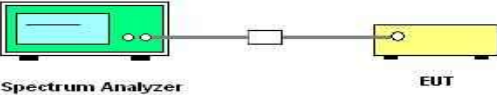
<b>Test Requirement:</b>	FCC Part15 C Section 15.247 (d)
<b>Test Method:</b>	ANSI C63.4:2009 and DA00-705
<b>Limit:</b>	In any 100 kHz bandwidth outside the intentional radiation frequency band, the radio frequency power shall be at least 20 dB below the highest level of the radiated power. In addition, radiated emissions which fall in the restricted bands must also comply with the radiated emission limits.
<b>Test Setup:</b>	 <p style="text-align: center;">Spectrum Analyzer                      EUT</p>
<b>Test Mode:</b>	Transmitting mode with modulation
<b>Test Procedure:</b>	<ol style="list-style-type: none"> <li>1. The testing follows the guidelines in Spurious RF Conducted Emissions of FCC Public Notice DA 00-705 Measurement Guidelines</li> <li>2. The RF output of EUT was connected to the spectrum analyzer by RF cable and attenuator. The path loss was compensated to the results for each measurement.</li> <li>3. Set to the maximum power setting and enable the EUT transmit continuously.</li> <li>4. Set RBW = 100 kHz, VBW = 300kHz, scan up through 10th harmonic. All harmonics / spurs must be at least 20 dB down from the highest emission level within the authorized band as measured with a 100 kHz RBW.</li> <li>5. Measure and record the results in the test report.</li> <li>6. The RF fundamental frequency should be excluded against the limit line in the operating frequency band.</li> </ol>
<b>Test Result:</b>	PASS

### 6.10.2. Test Instruments

RF Test Room				
Equipment	Manufacturer	Model	Serial Number	Calibration Due
Spectrum Analyzer	Agilent	N9020A	MY49100060	Oct. 21, 2015
RF cable	TCT	RE-06	N/A	Sep.15 , 2015
Antenna Connector	TCT	RFC-01	N/A	Sep.15 , 2015

**Note:** The calibration interval of the above test instruments is 12 months and the calibrations are traceable to international system unit (SI).

## 6.10.3. Test Data

GFSK mode

Lowest Channel

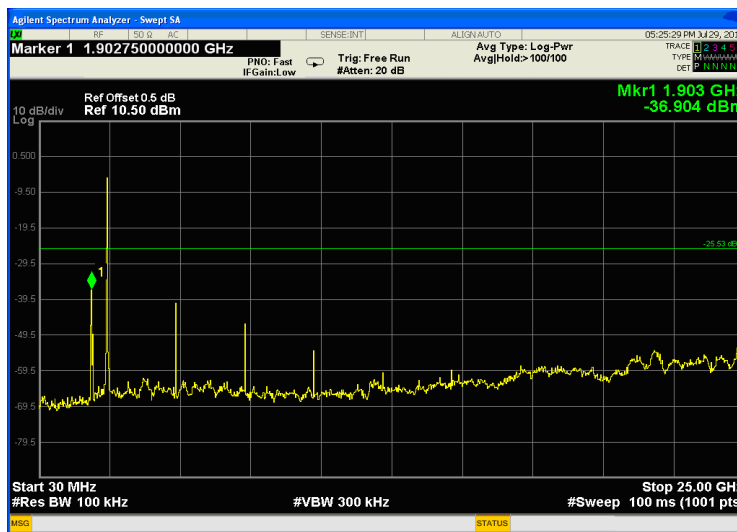

Middle Channel

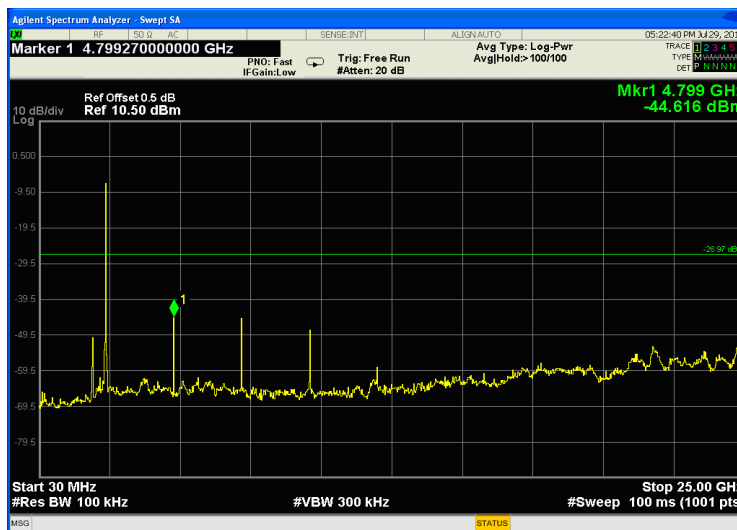

Highest Channel

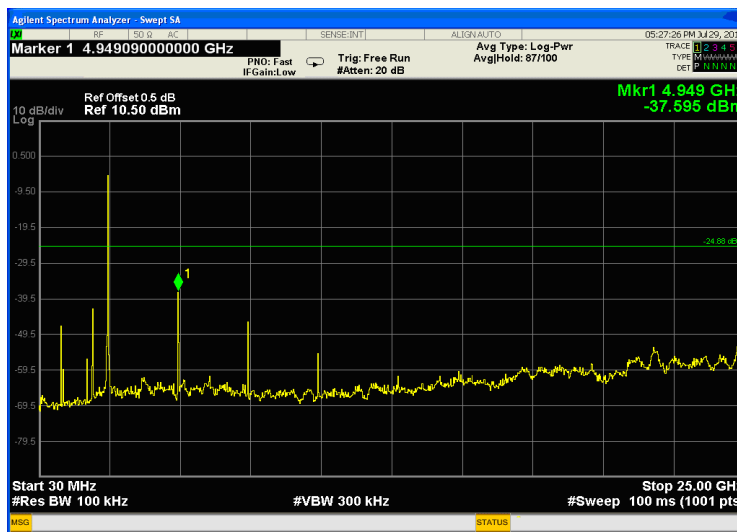

Pi/4DQPSK mode

Lowest Channel

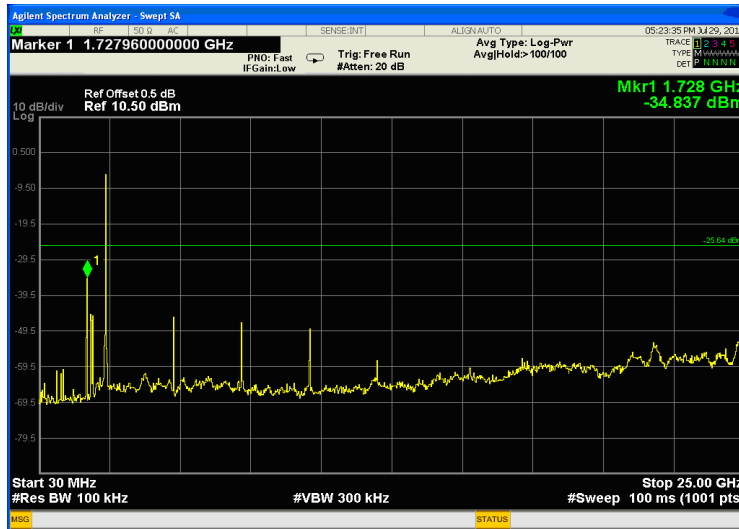

Middle Channel

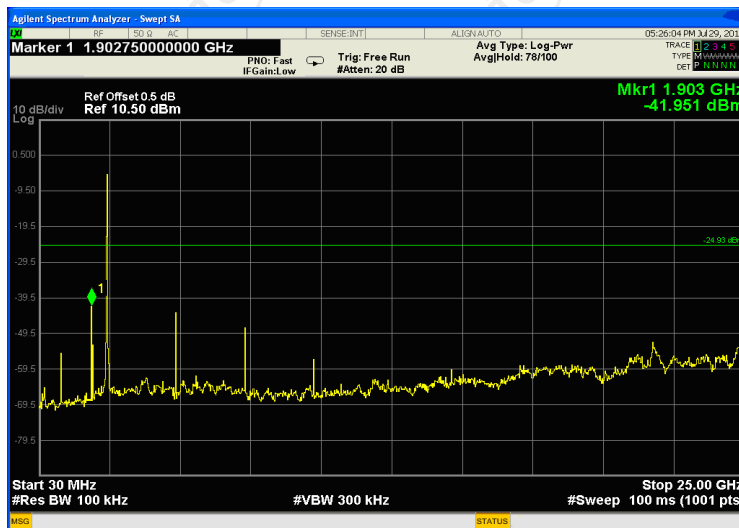

Highest Channel



8DPSK mode

Lowest Channel

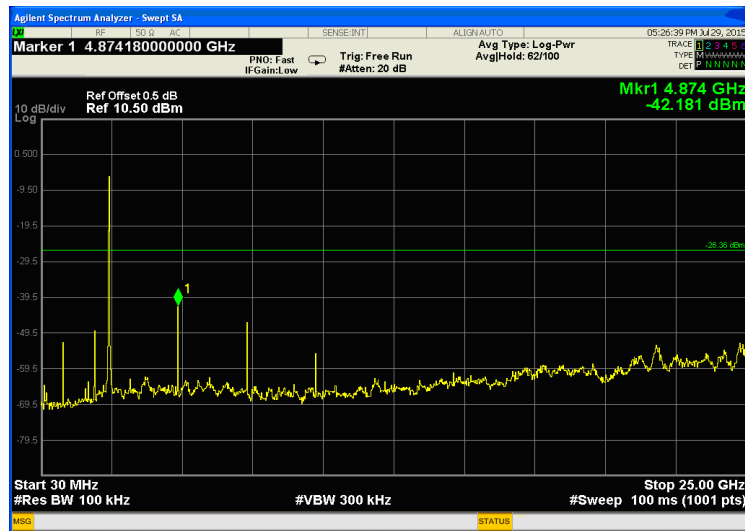

Middle Channel

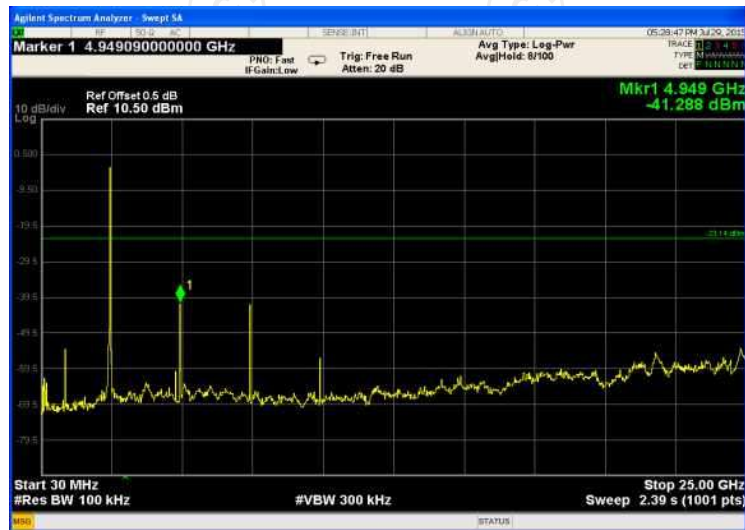

Highest Channel

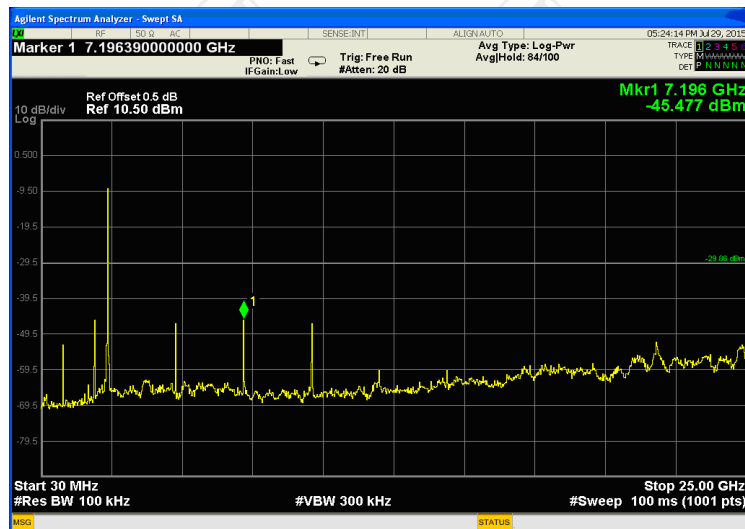

## 6.11. Radiated Spurious Emission Measurement

### 6.11.1. Test Specification

<b>Test Requirement:</b>	FCC Part15 C Section 15.209					
<b>Test Method:</b>	ANSI C63.4: 2009 and ANSI C63.10: 2009					
<b>Frequency Range:</b>	9 kHz to 25 GHz					
<b>Measurement Distance:</b>	3 m					
<b>Antenna Polarization:</b>	Horizontal & Vertical					
<b>Receiver Setup:</b>	Frequency	Detector	RBW	VBW	Remark	
	9kHz- 150kHz	Quasi-peak	200Hz	1kHz	Quasi-peak Value	
	150kHz- 30MHz	Quasi-peak	9kHz	30kHz	Quasi-peak Value	
	30MHz-1GHz	Quasi-peak	100KHz	300KHz	Quasi-peak Value	
	Above 1GHz	Peak	1MHz	3MHz	Peak Value	
		Peak	1MHz	10Hz	Average Value	
<b>Limit:</b>	Frequency		Field Strength (microvolts/meter)		Measurement Distance (meters)	
	0.009-0.490		2400/F(KHz)		300	
	0.490-1.705		24000/F(KHz)		30	
	1.705-30		30		30	
	30-88		100		3	
	88-216		150		3	
	216-960		200		3	
	Above 960		500		3	
	Frequency		Field Strength (microvolts/meter)	Measurement Distance (meters)	Detector	
	Above 1GHz		500	3	Average	
		5000	3	Peak		
<b>Test setup:</b>	For radiated emissions below 30MHz					
	<p>Distance = 3m</p> <p>EUT</p> <p>Turn table</p> <p>Ground Plane</p> <p>Computer</p> <p>Pre-Amplifier</p> <p>Receiver</p>					
	30MHz to 1GHz					

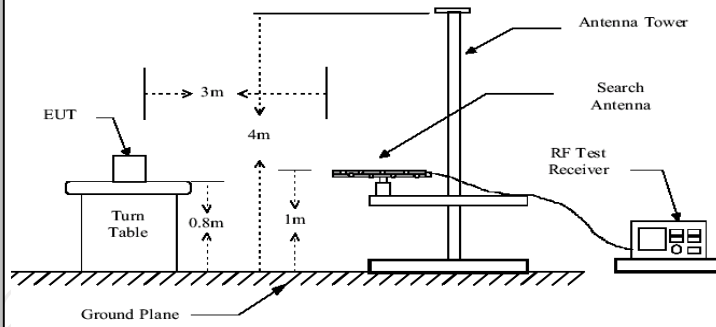

Above 1GHz

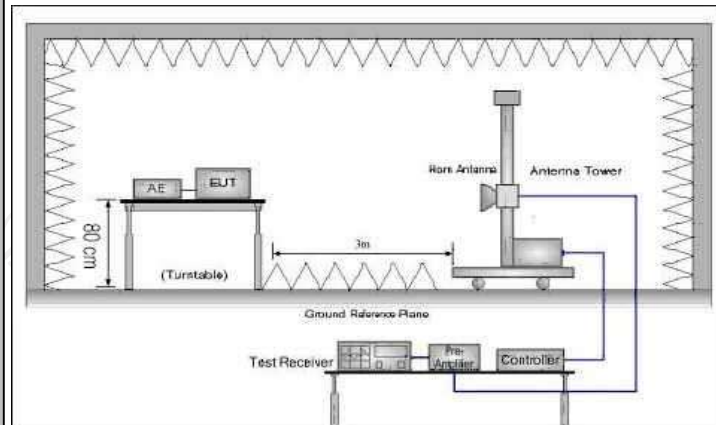

**Test Mode:**

Transmitting mode with modulation

**Test Procedure:**

1. The testing follows the guidelines in Spurious Radiated Emissions of FCC Public Notice DA 00-705 Measurement Guidelines.
2. For the radiated emission test below 1GHz:  
The EUT was placed on a turntable with 0.8 meter above ground. The EUT was set 3 meters from the interference receiving antenna, which was mounted on the top of a variable height antenna tower. The EUT was arranged to its worst case and then tune the antenna tower (from 1 m to 4 m) and turntable (from 0 degree to 360 degrees) to find the maximum reading. A pre-amp and a high pass filter are used for the test in order to get better signal level.
- For the radiated emission test above 1GHz:  
Place the measurement antenna on a turntable with 0.8 meter above ground, which is away from each area of the EUT determined to be a source of emissions at the specified measurement distance, while keeping the measurement antenna aimed at the source of emissions at each frequency of significant emissions, with polarization oriented for maximum response. The measurement antenna may have to be higher or lower than the EUT, depending on the radiation pattern of the emission and staying aimed at the emission source for

	<p>receiving the maximum signal. The final measurement antenna elevation shall be that which maximizes the emissions. The measurement antenna elevation for maximum emissions shall be restricted to a range of heights of from 1 m to 4 m above the ground or reference ground plane.</p> <p>3. Set to the maximum power setting and enable the EUT transmit continuously.</p> <p>4. Use the following spectrum analyzer settings:</p> <p>(1) Span shall wide enough to fully capture the emission being measured;</p> <p>(2) Set RBW=100 kHz for <math>f &lt; 1</math> GHz, RBW=1MHz for <math>f &gt; 1</math>GHz ; VBW<math>\geq</math>RBW; Sweep = auto; Detector function = peak; Trace = max hold for peak</p> <p>(3) For average measurement: use duty cycle correction factor method per 15.35(c). Duty cycle = On time/100 milliseconds On time = <math>N1 \cdot L1 + N2 \cdot L2 + \dots + Nn-1 \cdot Ln-1 + Nn \cdot Ln</math> Where N1 is number of type 1 pulses, L1 is length of type 1 pulses, etc. Average Emission Level = Peak Emission Level + <math>20 \cdot \log(\text{Duty cycle})</math></p> <p>Corrected Reading: Antenna Factor + Cable Loss + Read Level - Preamp Factor = Level</p>
<b>Test results:</b>	PASS

6.11.2. Test Instruments

Radiated Emission Test Site (966)				
Name of Equipment	Manufacturer	Model	Serial Number	Calibration Due
ESPI Test Receiver	ROHDE&SCHW ARZ	ESVD	100008	Sep.16 , 2015
Spectrum Analyzer	ROHDE&SCHW ARZ	FSEM	848597/001	Sep.16 , 2015
Spectrum Analyzer	Agilent	N9020A	MY49100060	Oct. 21, 2015
Pre-amplifier	EM Electronics Corporation CO.,LTD	EM30265	07032613	Sep.16 , 2015
Pre-amplifier	HP	8447D	2727A05017	Sep.16 , 2015
Loop antenna	ZHINAN	ZN30900A	12024	Dec.14 , 2015
Broadband Antenna	Schwarzbeck	VULB9163	340	Sep.16 , 2015
Horn Antenna	Schwarzbeck	BBHA 9120D	631	Sep.16 , 2015
Horn Antenna	Schwarzbeck	BBHA 9170	373	Sep.16 , 2015
Antenna Mast	CCS	CC-A-4M	N/A	N/A
Coax cable	TCT	RE-low-01	N/A	Sep.15 , 2015
Coax cable	TCT	RE-high-02	N/A	Sep.15 , 2015
Coax cable	TCT	RE-low-03	N/A	Sep.15 , 2015
Coax cable	TCT	RE-high-04	N/A	Sep.15 , 2015
EMI Test Software	Shurple Technology	EZ-EMC	N/A	N/A

**Note:** The calibration interval of the above test instruments is 12 months and the calibrations are traceable to international system unit (SI).



### 6.11.3. Test Data

#### Duty cycle correction factor for average measurement

DH5 on time (One Pulse) Plot on Channel 39

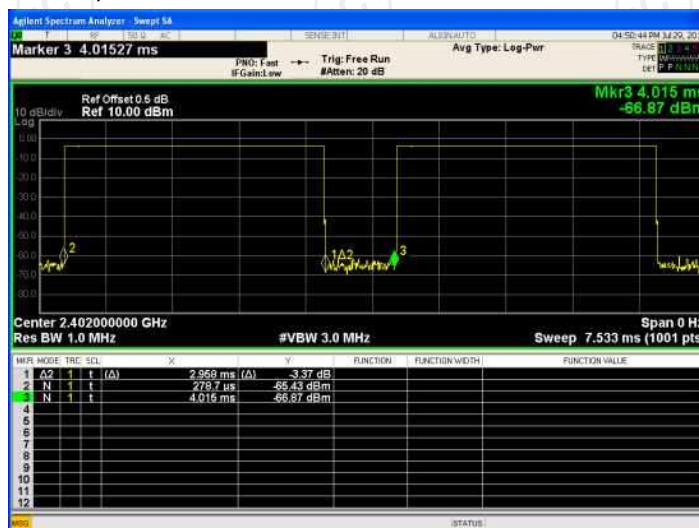

DH5 on time (Count Pulses) Plot on Channel 39

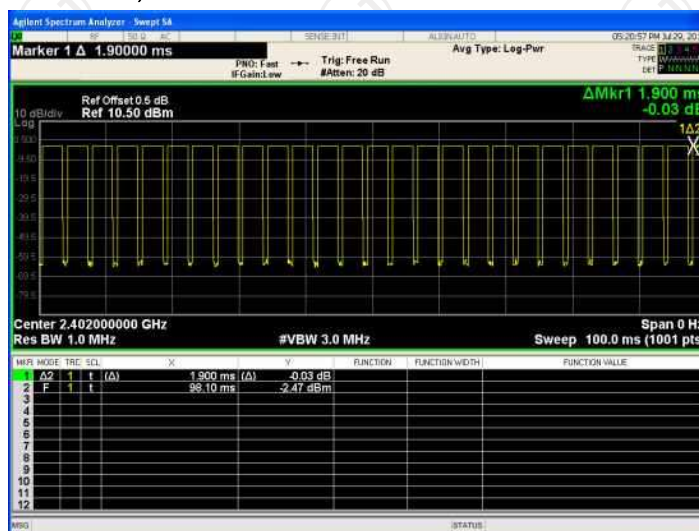

**Note:**

1. Worst case Duty cycle = on time/100 milliseconds =  $(2.958 \times 26 + 1.900) / 100 = 0.78808$
2. Worst case Duty cycle correction factor =  $20 \times \log(\text{Duty cycle}) = -2.07\text{dB}$
3. DH5 has the highest duty cycle worst case and is reported.
4. The average levels were calculated from the peak level corrected with duty cycle correction factor (-2.07dB) derived from  $20 \log(\text{dwell time}/100\text{ms})$ . This correction is only for signals that hop with the fundamental signal, such as band-edge and harmonic. Other spurious signals that are independent of the hopping signal would not use this correction.

Please refer to following diagram for individual

### Below 1GHz

Horizontal:



Site: Limit: FCC Part 15B Class B RE\_3 m      Polarization: **Horizontal**      Temperature: 25  
 Power: DC 3.7V      Humidity: 55 %

No.	Mk.	Freq. MHz	Reading Level dBuV	Correct Factor dB	Measure- ment dBuV/m	Limit dBuV/m	Over dB	Antenna Height cm	Table Degree	Comment
1		31.2920	37.43	-13.56	23.87	40.00	-16.13	peak	0	
2	*	39.1825	40.25	-12.57	27.68	40.00	-12.32	peak	0	
3		49.7571	36.71	-12.04	24.67	40.00	-15.33	peak	0	
4		137.8400	36.12	-15.31	20.81	43.50	-22.69	peak	0	
5		334.1255	40.53	-7.54	32.99	46.00	-13.01	peak	0	
6		527.5707	32.76	-2.68	30.08	46.00	-15.92	peak	0	

Vertical:

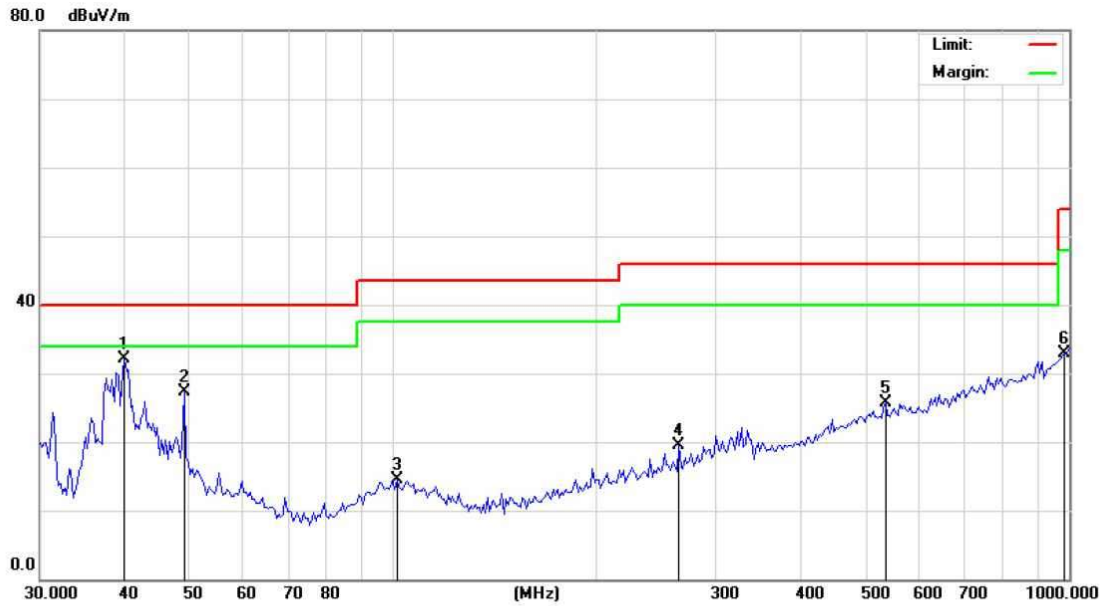

Site: Polarization: **Vertical** Temperature: 25  
 Limit: FCC Part 15B Class B RE\_3 m Power: DC 3.7V Humidity: 55 %

No.	Mk.	Freq. MHz	Reading Level dBuV	Correct Factor dB	Measure- ment dBuV/m	Limit dBuV/m	Over dB	Antenna Height cm	Table Degree degree	Comment
1	*	40.0172	44.61	-12.47	32.14	40.00	-7.86	peak	0	
2		49.0626	39.43	-12.08	27.35	40.00	-12.65	peak	0	
3		101.1796	26.09	-11.50	14.59	43.50	-28.91	peak	0	
4		264.9708	28.89	-9.45	19.44	46.00	-26.56	peak	0	
5		535.0376	28.21	-2.60	25.61	46.00	-20.39	peak	0	
6		986.0440	27.29	5.60	32.89	54.00	-21.11	peak	0	

**Note:** 1. The low frequency, which started from 9KHz~30MHz, was pre-scanned and the result which was 20dB lower than the limit line per 15.31(o) was not reported

2. Measurements were conducted in all three channels (high, middle, low) and three modulation(GFSK, Pi/4 DQPSK, 8DPSK), and the worst case Mode (high channel and 8DPSK) was submitted only.

## Above 1GHz

Modulation Type: 8DPSK  
Low channel: 2402 MHz

Frequency (MHz)	Ant. Pol. H/V	Peak reading (dBμV)	AV reading (dBμV)	Correction Factor (dB/m)	Emission Level		Peak limit (dBμV/m)	AV limit (dBμV/m)	Margin (dB)
					Peak (dBμV/m)	AV (dBμV/m)			
2390	H	48.59	---	-8.27	40.32	---	74	54	-13.68
4804	H	49.86	---	0.66	50.52	---	74	54	-3.48
7206	H	40.58	---	9.5	50.08	---	74	54	-3.92
---	H	---	---	---	---	---	---	---	---
2390	V	49.95	---	-8.27	41.68	---	74	54	-12.32
4804	V	49.99	---	0.66	50.65	---	74	54	-3.35
7206	V	40.89	---	9.5	50.39	---	74	54	-3.61
---	V	---	---	---	---	---	---	---	---

Middle channel: 2441 MHz

Frequency (MHz)	Ant. Pol. H/V	Peak reading (dBμV)	AV reading (dBμV)	Correction Factor (dB/m)	Emission Level		Peak limit (dBμV/m)	AV limit (dBμV/m)	Margin (dB)
					Peak (dBμV/m)	AV (dBμV/m)			
4882	H	48.46	---	0.99	49.45	---	74	54	-4.55
7323	H	38.85	---	9.87	48.72	---	74	54	-5.28
---	H	---	---	---	---	---	---	---	---
4882	V	49.9	---	0.99	50.89	---	74	54	-3.11
7323	V	40.75	---	9.87	50.62	---	74	54	-3.38
---	V	---	---	---	---	---	---	---	---

High channel: 2480 MHz

Frequency (MHz)	Ant. Pol. H/V	Peak reading (dBμV)	AV reading (dBμV)	Correction Factor (dB/m)	Emission Level		Peak limit (dBμV/m)	AV limit (dBμV/m)	Margin (dB)
					Peak (dBμV/m)	AV (dBμV/m)			
2483.5	H	46.96	---	-7.83	39.13	---	74	54	-14.87
4960	H	49.5	---	1.33	50.83	---	74	54	-3.17
7440	H	40.25	---	10.22	50.47	---	74	54	-3.53
---	H	---	---	---	---	---	---	---	---
2483.5	V	48.35	---	-7.83	40.52	---	74	54	-13.48
4960	V	49.6	---	1.33	50.93	---	74	54	-3.07
7440	V	40.02	---	10.22	50.24	---	74	54	-3.76
---	V	---	---	---	---	---	---	---	---

**Note:**

1. Emission Level=Peak Reading + Correction Factor; Correction Factor= Antenna Factor + Cable loss – Pre-amplifier
2. Margin (dB) = Emission Level (Peak) (dBμV/m)-Average limit (dBμV/m)
3. The emission levels of other frequencies are very lower than the limit and not show in test report.
4. Measurements were conducted from 1 GHz to the 10th harmonic of highest fundamental frequency.
5. Data of measurement shown "—" in the above table mean that the reading of emissions is attenuated more than 20 dB below the limits or the field strength is too small to be measured.
6. Measurements were conducted in all three modulation(GFSK, Pi/4 DQPSK, 8DPSK), and the worst case Mode 8DPSK was submitted only.

**\*\*\*\*\*END OF REPORT\*\*\*\*\***