

Kodak

PIXPRO AZ525

Digital Camera



User Manual



Before You Start

Declaration of Conformity

Responsible Party: JK Imaging Ltd.
Address: 1411 W. 190th Street, Suite 550, Gardena, CA 90248, USA
Company Website: www.kodakpixpro.com

INDUSTRY CANADA

This device complies with Canadian RSS-210.

This device complies with Industry Canada license-exempt RSS standard (s). Operation is subject to the following two conditions: (1) this device may not cause interference, and (2) this device must accept any interference, including interference that may cause undesired operation of the device.

Radiation Exposure Statement:

This product complies with the Canadian portable RF exposure limit set forth for an uncontrolled environment and is safe for intended operation as described in this manual. Additional RF exposure reduction can be achieved if the product can be kept as far as possible from the user body or set the device to lower output power if such function is available.

Industry Canada statement:

Ce dispositif est conforme à la norme CNR-210 d'Industrie Canada applicable aux appareils radio exempts de licence. Son fonctionnement est sujet aux deux conditions suivantes: (1) le dispositif ne doit pas produire de brouillage préjudiciable, et (2) ce dispositif doit accepter tout brouillage reçu, y compris un brouillage susceptible de provoquer un fonctionnement indésirable.

Déclaration d'exposition aux radiations:

Le produit est conforme aux limites d'exposition pour les appareils portables RF pour les Etats-Unis et le Canada établies pour un environnement non contrôlé.

Le produit est sûr pour un fonctionnement tel que décrit dans ce manuel. La réduction aux expositions RF peut être augmentée si l'appareil peut être conservé aussi loin que possible du corps de l'utilisateur ou que le dispositif est réglé sur la puissance de sortie la plus faible si une telle fonction est disponible.

For Customers in Europe



This symbol [crossed-out wheel bin WEEE Annex IV] indicates separate collection of electrical waste and electronic equipment in the European countries. Please do not throw the equipment into domestic refuse. Please use the return and collection systems available in your country for proper, safe disposal of this product.



"CE" mark indicates that this product complies with the European requirements for safety, health, environment and customer protection. "CE" marked cameras are intended for sales in Europe.

Europe – EU Declaration of Conformity

This device complies with the essential requirements of the R&TTE Directive 1999/5/EC. The following test methods have been applied in order to prove presumption of conformity with the essential requirements of the R&TTE Directive 1999/5/EC:

- EN 60950-1: 2006+A11:2009 +A1:2010 +A12:2011

Safety of Information Technology Equipment

- EN 50566: 2013

Product standard to demonstrate compliance of radio frequency fields from handheld and body-mounted wireless communication devices used by the general public (30 MHz — 6 GHz)

- EN 62209-2: 2010

Human exposure to radio frequency fields from handheld and bodymounted wireless communication devices — Human models, instrumentation, and procedures

Part 2: Procedure to determine the specific absorption rate (SAR) for wireless communication devices used in close proximity to the human body (frequency range of 30 MHz to 6 GHz)

- EN 300 328 V1.8.1 : 2012

Electromagnetic compatibility and Radio spectrum Matters (ERM); Wideband Transmission systems; Data transmission equipment operating in the 2.4 GHz ISM band and using spread spectrum modulation techniques; Harmonized EN covering essential requirements under article 3.2 of the R&TTE Directive.

- EN 301 489-1 V1.9.2: 2008

Electromagnetic compatibility and Radio Spectrum Matters (ERM); Electro Magnetic Compatibility (EMC) standard for radio equipment and services; Part 1: Common technical requirements.

- EN 301 489-17 V2.2.1:2012

Electromagnetic compatibility and Radio spectrum Matters (ERM); Electro Magnetic Compatibility (EMC) standard for radio equipment and services; Part 17: Specific conditions for 2.4 GHz wideband transmission systems and 5 GHz high performance RLAN equipment.

For Customers in the U.S.A.

Federal Communication Commission Interference Statement

This device complies with Part 15 of the FCC Rules. Operation is subject to the following two conditions: (1) This device may not cause harmful interference, and (2) this device must accept any interference received, including interference that may cause undesired operation.

This equipment has been tested and found to comply with the limits for a Class B digital device, pursuant to Part 15 of the FCC Rules. These limits are designed to provide reasonable protection against harmful interference in a residential installation. This equipment generates, uses and can radiate radio frequency energy and, if not installed and used in accordance with the instructions, may cause harmful interference to radio communications. However, there is no guarantee that interference will not occur in a particular installation. If this equipment does cause harmful interference to radio or television reception, which can be determined by turning the equipment off and on, the user is encouraged to try to correct the interference by one of the following measures:

- Reorient or relocate the receiving antenna.
- Increase the separation between the equipment and receiver.
- Connect the equipment into an outlet on a circuit different from that to which the receiver is connected.
- Consult the dealer or an experienced radio/TV technician for help.

FCC Caution: Any changes or modifications not expressly approved by the party responsible for compliance could void the user's authority to operate this equipment.

This transmitter must not be co-located or operating in conjunction with any other antenna or transmitter.

Radiation Exposure Statement:

This product complies with the FCC portable RF exposure limit set forth for an uncontrolled environment and is safe for intended operation as described in this manual. Additional RF exposure reduction can be achieved if the product can be kept as far as possible from the user body or set the device to lower output power if such function is available.

About this Manual

Thank you for purchasing the KODAK PIXPRO Digital Camera. Please carefully read this manual and keep it well for future reference.

- JK Imaging Ltd. reserves all rights of this document. No part of this published manual may be reproduced, transmitted, transcribed, stored in a retrieval system or translated into any language or computer language, in any form, by any means, without the prior written permission of JK Imaging Ltd..
- All trademarks mentioned in this manual are used for identification purposes only and are properties of their respective owners.
- This manual provides you with instructions on how to use your new KODAK PIXPRO Digital Camera. Every effort has been made to ensure that the contents of this manual are accurate; however JK Imaging Ltd. reserves the right to make changes without notice.
- Throughout this manual, the following symbols are used to help you locate information quickly and easily:



Indicates useful information.



Indicates precautions are to be taken while operating the camera.

- In introducing you how to operate this camera, the following symbols may appear to facilitate your understanding:

[Item properties] : The optional properties in the camera interface are indicated by the symbol [] .

Safety Notes

Safety notes for this camera

- Do not drop the camera or allow it to hit solid objects.
- Do not disassemble or repair this camera by yourself.
- To prevent the camera from being damaged by moisture, do not use or store the camera in very humid environments, such as in rain or near bodies of water.
- Do not use or store the camera in dusty places or on a beach to prevent dust or sand from entering the camera, causing possible damage to it.
- Do not use or store the camera in a hot environment or under direct sunlight.
- Do not use or store the camera near a powerful magnetic field, for example near a magnet or transformer.
- Avoid touching the lens of the camera.
- Do not expose the camera to direct sunlight for a long period time.
- Turn the camera off, remove the battery and the memory card, and dry it within 24 hours if water accidentally comes in contact with the camera.
- When you take the camera from a cold place to a warmer environment, condensation may occur. Please wait for a reasonable period of time before you turn it on.
- Before you remove the battery and memory card, the camera should be turned off.
- In cleaning the camera body, please don't use corrosive cleaning agents or those with alcohol or organic solvent.
- Use the professional lens wiping cloth and dedicated cleaner to wipe and clean the lens.
- Download your photos and remove the memory card when you are going to store the camera for a long period of time.
- If this camera is not in use for a long time, please keep it in a dry and clean condition.
- Our company will not pay compensation for any failure of playback of pictures or videos caused by improper operation.

Safety notes for battery

- Please use a battery that is the same type as the one included.
- Please use the attached charger to charge the battery.
- If the liquid leaking from the battery contacts with your skin, please immediately flush with water and seek medical treatment. If the liquid leaks into the camera, please contact the retailer.
- Please dispose the wasted battery in accordance with local (national or regional) regulations.
- To prevent the battery from being damaged, do not drop the battery or allow it to hit solid objects or to be scratched by the objects.
- Do not let the battery come in contact with metal objects (including coins) to avoid short circuiting, discharging, excessive heat, or possible leakage.
- Do not attempt to disassemble the battery.
- Do not expose the battery to water. Always keep the battery contacts dry.
- Do not heat the battery or throw it into a fire to avoid a possible explosion.
- Do not store the battery in a hot environment or in direct sunlight.
- If an overheating happens during charging or use, please immediately stop charging or using and then take out the battery with care in shutdown mode to wait it for cooling.
- If it is not used for a long time, please remove the battery for proper keeping.
- In a colder environment, the performance of the battery could be noticeably reduced.
- When you install the battery, install it according to the positive and negative markings on the battery compartment. Never force it into the battery compartment.

Safety notes for memory card

- We suggest buying only well-known, name brand memory cards to ensure peak performance.
- Format the memory card using the camera before you use it or insert a new one.
- Do not make the memory card fall off from high places or hit by heavy objects to prevent damaging it.
- Do not attempt to disassemble or repair the memory card.
- Do not expose the memory card to water. Always keep it dry.
- Do not remove the memory card when the camera is turned on. Otherwise, the memory card could be damaged.
- Do not directly edit the data on the memory card. Copy the data to your PC before you edit them.
- When the camera is stored for a long period of time, be sure to download your photos and remove the memory card. Store it in a dry environment.
- Do not modify the name of the files or folders of the memory card using your PC. Modifying the file names may cause the files to not be recognized on the camera or a possible error may occur.
- A photo taken with the camera will be stored in the folder that is automatically generated on the memory card. Do not store photos that are not taken using this camera in these folders as the pictures cannot be recognized during the playback.
- When you insert a memory card, make sure the notch of the card matches the markings on the top of the card slot.

Other Safety Notes

- Do not disconnect the power or turn the camera off during the update process. Doing so may cause incorrect data to be written and the camera may not power on later.
- Do not hang the neck strap of the camera around the neck of a child.
- When using your camera on an airplane, observe the relevant rules specified by the airline.
- Due to the limitations of manufacturing technology, LCD may have a few dead or bright pixels. These pixels do not affect the quality or performance of the camera, photos or video.
- Do not expose LCD to water. In a humid environment, only wipe it with a soft and dry cleaning cloth.
- If LCD is damaged and the liquid crystal comes into contact with your skin, wipe your skin with a dry cloth immediately and rinse it with clean water. If liquid crystal comes into contact with your eyes, wash them with clean water at least for 15 minutes and seek immediate medical attention. If you accidentally swallow liquid crystal, rinse your mouth immediately and seek medical attention.

Contents

Before You Start.....	1	Set your Language, Date/Time after the first power-on	24
Safety Notes	6	Resetting your Language.....	25
Contents.....	10	Resetting Date/Time	26
Getting Ready	15	Mode Overview	27
Accessories Included.....	15	Display Setting.....	27
Install Lens Cap and Neck Strap.....	16	LCD Display	28
Part Names	17	Overview of the screen icons in photo shooting mode	28
Installing Battery and Memory Card	19	Overview of the screen icons in movie mode.....	29
Charging Battery.....	21	Overview of the screen icons in playback mode.....	30
Turning Camera On and Off	23	Using the Mode Dial.....	31
Set your Language, Date/Time	24		

Select an appropriate capture mode.....	31	Focus Setting.....	54
Auto Mode.....	32	Macro Mode.....	55
Program AE.....	34	Self-timer Setting.....	56
Shutter priority.....	34	Flash Mode.....	57
Aperture priority.....	34	White Balance Setting.....	58
Manual Mode.....	34	Continuous Shot.....	59
Face Beautifier.....	36	EV Settings.....	60
Wi-Fi Mode.....	37	Exposure Compensation.....	60
Scene Mode.....	45	ISO.....	61
Movie Mode.....	50	Shutter Adjustment.....	61
Custom Settings.....	51	Aperture Adjustment.....	62
Basic Operation.....	53	Using Quick Recording.....	62
Using the Zoom Function.....	53	i Button Function Menu.....	63

Playback Mode	64	OIS (Optical Image Stabilization)	73
Viewing Photos and Videos.....	64	Cont. AF	73
Thumbnail View	65	HDR	74
Using Zoom Playback (for still pictures only)	66	Beautifier	74
Photos and Video Deletion.....	67	Scene	75
Slideshow	68	Photo Shooting Settings Menu	76
Continuous Capture Group Playback.....	69	Quality	76
Animation panorama play	70	AF-Assist Beam.....	77
Using the Menus	71	Digital Zoom	77
Photo Setup Menu.....	71	Date Imprint	77
Expo Metering	71	Quick Review	78
Image Size	72	Custom Settings.....	78
		Movie Menu	79

Expo Metering.....	79	Playback Settings Menu.....	88
Movie Size.....	80	Protect.....	89
OIS (Optical Image Stabilization)	81	Delete.....	90
Movie Setting Menu	82	DPOF (Digital Print Order Format)..	91
Digital Zoom.....	83	Trim.....	91
Custom Settings.....	83	General Settings Menu	92
Playback Menu.....	84	Sound Settings	93
Playback Mode.....	84	Power Saver	93
HDR	85	Language	94
Touch-up.....	85	Zone.....	94
Rotate.....	86	Date/Time	94
Resize	86	LCD Brightness.....	94
i button playback function	87	File Settings	95

Format.....	96
Copy to Card.....	96
File Numbering.....	97
Reset.....	97
FW Version	98

Using the PictBridge Menu.....	104
Video System	108
Set Eye-Fi SD Card Connection Mode..	109
Supported HDMI Connections.....	110
Connecting HDMI-Ready TV	110

Connection Settings99

Connecting to a Computer	100
Setting the USB Mode	100
Transferring files to your computer.....	101
Connecting to a PictBridge Compatible Printer.....	102
Setting the USB Mode	102
Connecting to your Printer	103

Appendices..... 111

Product Specifications.....	111
Prompts and Warning Messages.....	115
Troubleshooting.....	119

Getting Ready

Accessories Included

Your camera box should contain the camera model you purchased along with the following accessories. If anything is missing or appears to be damaged, please contact your retailer. (The battery chargers may be a little different in shape due to the difference of countries or regions this type of cameras are sold to, so please subject to the physical product.)

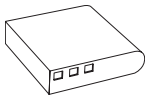

Rechargeable
Li-ion battery

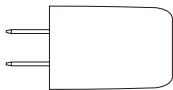

AC adapter

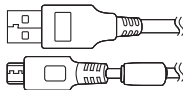

Micro USB cable

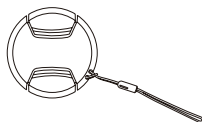

Lens cap with strap



Neck strap



Quick start guide



Warranty card



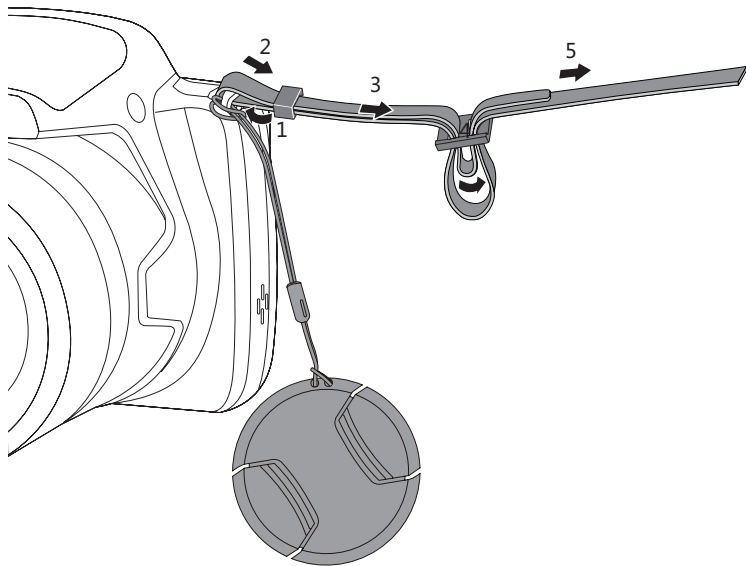

Service card

Install Lens Cap and Neck Strap



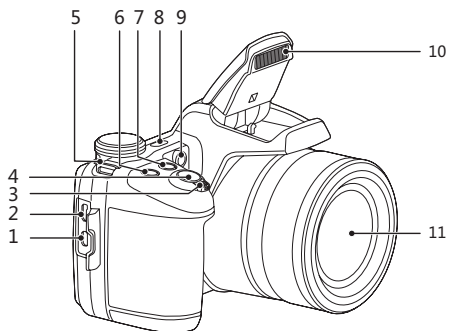





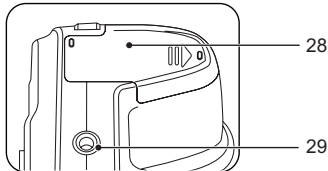
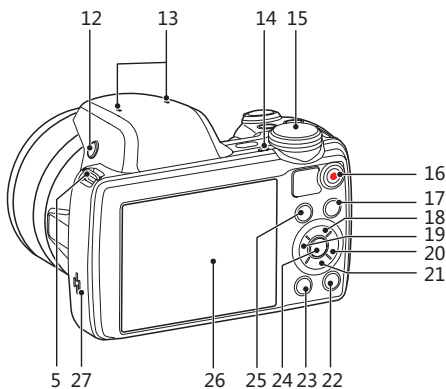



Part Names



1. Micro HDMI port
2. Micro USB port
3. Zoom lever
4. Shutter button
5. Strap eyelet
6.  Exposure compensation button
7.  Continuous shot button
8. Power button
9. AF assist beam/Self-timer lamp
10. Flash lamp
11. Lens



12. Flash button
13. Microphone
14. Indicator lamp
15. Mode dial
16.  Fast video recording button
17.  Menu button
18.  AF button/Up button
19.  Macro button/Left button
20.  Flash button/Right button
21.  Delete button/Self-timer button/Down button
22.  Display button
23.  Playback button
24.  SET button
25.  i button
26. LCD
27. Speaker
28. Battery cover
29. Tripod socket

Installing Battery and Memory Card

1. Open the battery cover according to the direction of arrow.
2. Insert the battery into the battery compartment according to the negative and positive directions as illustrated in the picture. Push the battery down until it locks in place.

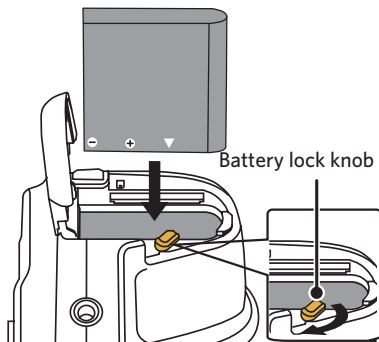
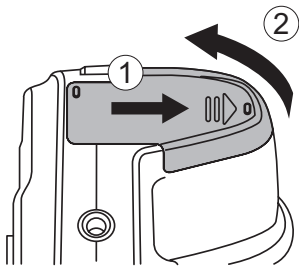

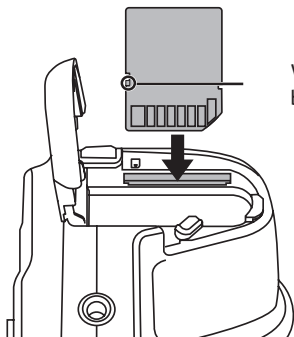

-
3. Insert the memory card into the memory card slot as shown in the diagram.

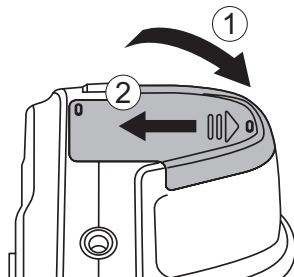

Write protection
buckle

4. Close the battery cover.



 The memory card (SD/SDHC) is optional and not included in all camera packaging. If you have to purchase a memory card, select one with storage capacity between 4GB and 32GB to ensure correct data storage.

 To remove your memory card, open the battery cover, gently press the memory card to eject it and remove it carefully.

Charging Battery

Please insert the battery and charge it under shutdown mode.

1. Connect the camera and the power charger using the supplied Micro USB cable.
2. Insert the plug of the power charger into the power outlet to charge the battery.

 After the battery is stored for a long period of time, use the supplied power charger to charge the battery prior to use.

 To have maximum battery life, charge the battery for at least 4 hours the first time.

 **Charging indicator:**
Steady orange: Charging
The indicator will go out once charging is finished, and the camera will be powered off automatically.

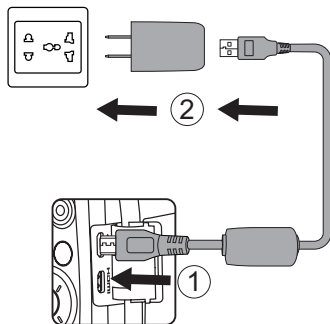

Indicator lamp

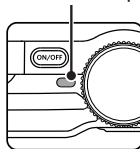

-
3. When the camera is turned off, you can also connect the camera to your PC using a USB cable to charge the battery.

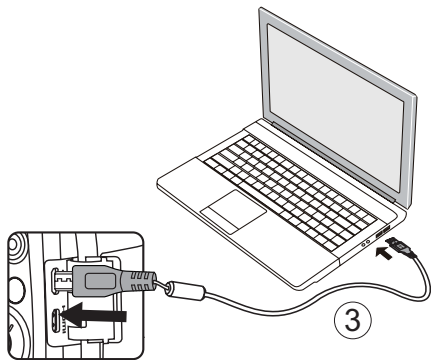

Please charge the battery indoors between 0°C and 40°C.

Turning Camera On and Off

Press the Power button to turn the camera on. To turn the camera off, press the Power button again.

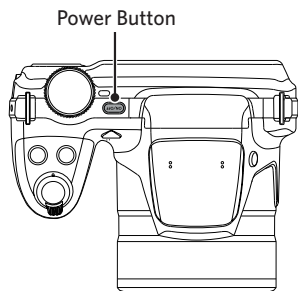

Press and hold the  button to power on and enter Playback mode.

Set your Language, Date/Time

Set your Language, Date/Time after the first power-on

1. When you turn the camera on for the first time, the language selection screen appears.
2. Press the [▲AF] / [▼🗑️🕒] / [◀️🌸] / [▶️⚡] buttons to select your desired language.
3. After you press the (SET) button to confirm the selection, the Date/Time settings screen appears.
4. Press the [◀️🌸] / [▶️⚡] button to select the Date/Time to be adjusted: Time is displayed in yyyy:MM:dd HH:mm.
5. Press the [▲AF] / [▼🗑️🕒] button to adjust the value for the selected Date/Time.
6. Press the (SET) button to confirm the time settings and the shooting screen appears.

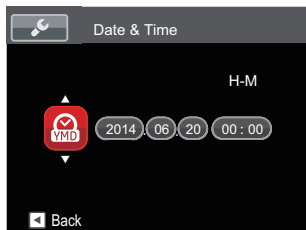

Resetting your Language





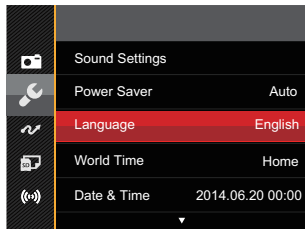











After you set your language for the first time, follow the instructions below to reset your language.

1. Press the button, press the [**▲AF**] / [**▼**] button to select , and press the button to enter the menu.
2. Press the [**▲AF**] / [**▼**] button to select , and press the button or the [**▶**] button to enter the menu.
3. Press the [**▲AF**] / [**▼**] button to select [Language] and press the button or the [**▶**] button to enter the menu.
4. Press the [**▲AF**] / [**▼**] / [**◀**] / [**▶**] buttons to select your desired language and press the button to confirm.
5. Press the button and the shooting screen appears.



Resetting Date/Time

After you set your Date/Time for the first time, follow the instructions below to reset date and time.

1. Press the  button, press the [**▲AF**] / [**▼**  ] button to select , and press the  button to enter the menu.
2. Press the [**▲AF**] / [**▼**  ] button to select , and press the  button or the [**▶⚡**] button to enter the menu.
3. Press the [**▲AF**] / [**▼**  ] button to select [Date & Time] and press the  button or the [**▶⚡**] button to enter the menu.
4. Press the [**◀🌸**] / [**▶⚡**] button to select the Date/Time to be adjusted: Time is displayed in yyyy:MM:dd HH:mm.
5. Press the [**▲AF**] / [**▼**  ] button to press the value for your selected block. After you finish your settings, press the  button to confirm.
6. Press the  button and the shooting screen appears.

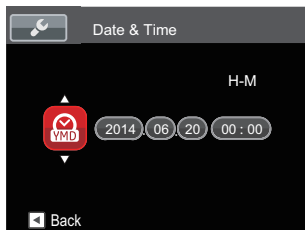
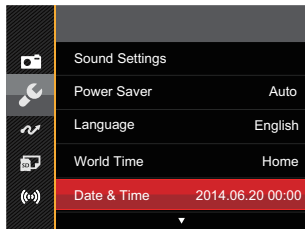

Mode Overview

Display Setting

Press the  button to display the settings: Classic, Full, Off.

Classic: Displays the camera parameters on screen



Off: Does not display any additional icons on screen

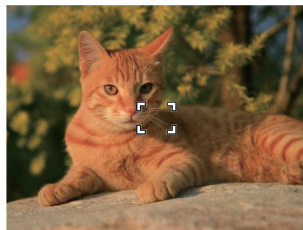

Full: Camera parameters with Grid and Histogram

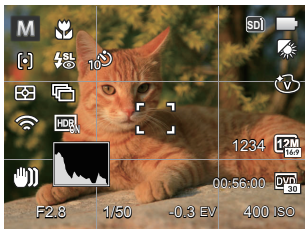

LCD Display

Overview of the screen icons in photo shooting mode

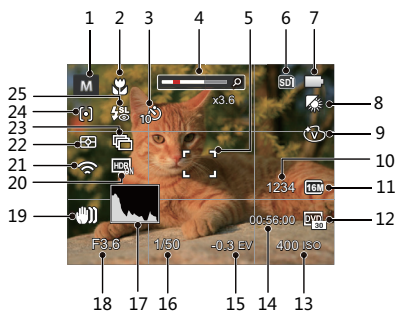

- 1 Shooting Mode
- 2 Macro Mode
- 3 Self-timer
- 4 Zoom Display (By turning the Zoom Lever)
- 5 Focus Frame
- 6 SD Memory Card/Built-in Memory
- 7 Battery Status
- 8 White Balance
- 9 Color Effect
- 10 Number of remaining shots
- 11 Image Size
- 12 Video Quality
- 13 ISO Value
- 14 Remaining Recording Time
- 15 Exposure Compensation
- 16 Shutter Speed
- 17 Histogram
- 18 Aperture Value
- 19 OIS (Optical Image Stabilization)
- 20 HDR
- 21 Eye-Fi ON (with signal)
- 22 Expo Metering
- 23 Continuous Shot
- 24 AF Mode
- 25 Flash Mode

Overview of the screen icons in movie mode

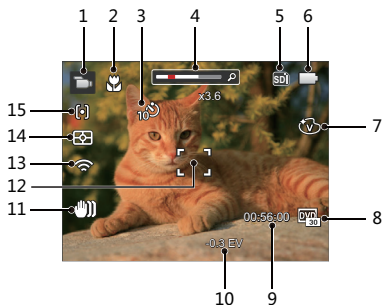

- 1 Movie Mode
- 2 Macro Mode
- 3 Self-timer
- 4 Zoom Display (By turning the Zoom Lever)
- 5 SD Memory Card/Built-in Memory
- 6 Battery Status

- 7 Color Effect
- 8 Video Quality
- 9 Remaining Recording Time
- 10 Exposure Compensation
- 11 OIS (Optical Image Stabilization)
- 12 Focus Frame
- 13 Eye-Fi ON (with signal)
- 14 Expo Metering
- 15 AF Mode

 For optimal video shooting, it is recommended that an SDHC memory card be used.

 Optical Zoom and Digital Zoom can be adjusted (208X in total). Digital Zoom can be adjusted to 4X.

Overview of the screen icons in playback mode

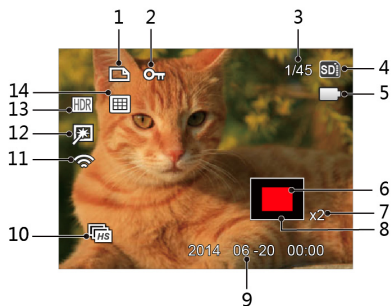

- 1 DPOF File
- 2 File Protection
- 3 Memory Space (indicating the current number of photos and total number of photos)

- 4 SD Memory Card/Built-in Memory
- 5 Battery Status
- 6 Zoom Magnification Area
- 7 Image Zoom Ratios
- 8 Image Zone
- 9 Shooting Date
- 10 Continuous Capture Group Playback
- 11 Eye-Fi ON (with signal)
- 12 Red-Eye Reduction
- 13 HDR
- 14 Date Folder

Using the Mode Dial

This camera provides a convenient mode dial that allows you to manually switch between different modes with ease.

Select an appropriate capture mode

1. Press the Power button to turn the camera on, and make camera lens focus on the subject to be shot then find a view by the LCD.
2. Rotate the mode dial to select an appropriate shooting mode.



Auto Mode



Manual Mode



Movie Mode



Program AE



Face Beautifier



Custom Settings



Shutter priority



Wi-Fi Mode



Aperture priority



Scene Mode

3. Rotate the zoom lever to zoom in or out of the subjects and compose a photo within the framing scope.
4. Press the Shutter button half way down to focus on the subject. When the focus frame turns green, press the Shutter button completely down to take the picture.

Auto Mode

The camera will automatically detect the most suitable scene to capture the best pictures.

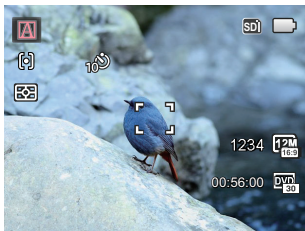

Auto Mode

The camera will automatically adjust the exposure and focus to ensure the best possible pictures.

Landscape Mode

For landscapes, will automatically adjust the exposure and reproduce vivid green and blue colors.

Portrait Mode

Most suitable for capturing people with focus on their faces.

Night Portrait

When you take portraits at night, or in low light conditions, will automatically adjust the exposure for people and night scenes.

Backlit Portrait

When the sun or any other light source is behind you, will automatically adjust the foreground exposure to produce the best pictures possible.

Night Mode

For night scenes, will automatically increase the ISO value to compensate for low light.

Macro Mode

To produce more detailed close-ups, will automatically engage the camera's Macro Mode and automatically focus the lens.

Program AE P

The user can switch the ISO and EV value according to personal preference, the camera can automatically set the shutter speed and aperture value.

Shutter priority S

The user can adjust the shutter speed, EV and ISO values. It is mostly used to shoot the moving object.

Aperture priority A

The user can adjust the aperture size, EV and ISO values. It is generally used to shoot inanimate object and control the view depth.

Manual Mode M





The user can adjust the aperture size, EV and ISO values manually. It is generally used to shoot static photos.

Mode: PSAM

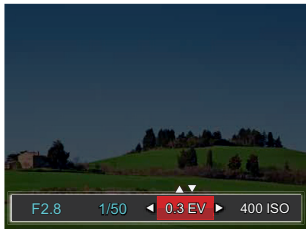
Follow the steps below to adjust the parameters:

1. Rotate the mode dial to select a mode you want, press the  button to configure settings.







2. Press the [] / [] button to select an adjustment item.
3. Press the [] / [] button to adjust the parameters.
4. Press the  button to confirm the settings and enter the shooting screen.

Items that can be adjusted under **PSAM** mode: (O: Optional X: Not optional, auto display)



Mode \ Items	Aperture value	Shutter speed	EV value	ISO value
P	X	X	O	O
S	X	O	O	O
A	O	X	O	O
M	O	O	X	O

Face Beautifier

The camera is set to automatically adjust camera exposure for realistic portrayal of skin tones.

1. Rotate the mode dial to select .
2. Press the  button and press the [AF] / [ ] button to select .
3. Press the [ ] button to select an option and press the  button to confirm and return to photo shooting mode.



-  Effect 1: Skin Soften
-  Effect 2: Skin Soften+Eye Brightening
-  Effect 3: Skin Soften+Eye Brightening+Eye Enlargement

Wi-Fi Mode

Make image transmission and remote control by connecting smart device with Wi-Fi.

Matters needing attention before use

- Before use, please confirm that your smart device is a smart phone with Android 2.3 or 4.x system, a tablet computer with Android 4.x or is an iOS 6/7 system. If not, please upgrade your smart device before using the APP.
- Please do not use in places having high intensity magnetic field, electrostatic and electric wave interference (for example near a microwave oven), which may cause failure in receiving signals.
- To maintain a connection, please keep the camera within 10 meters (32.8 feet) without signal shielding interference.
- Please do not use Wi-Fi connection functionality on a plane.
- The camera and the smart device can only be connected one to one.

Route of downloading the APP package:



Please download APP installation package(APP name: PIXPRO Remote Viewer) to your smart device from the path below and install this application procedure according to the interface prompt.



Search for "PIXPRO Remote Viewer" from Google play and install it.



<https://play.google.com/store/apps/details?id=com.jkimaging.pixproremoteviewer>



Search for "PIXPRO Remote Viewer" from APP Store and install it.



<https://itunes.apple.com/us/app/pixpro-remote-viewer/id833154167?mt=8>

Refer to the "PIXPRO Remote Viewer User Manual" located on the web:

Americas



<http://kodakpixpro.com/Americas/support/downloads.php>

Europe



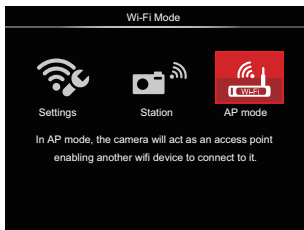

<http://www.kodakpixpro.com/Europe/support/multi-lang-downloads.php>

-
1. Rotate the mode dial to select  and then enter the Wi-Fi selection interface.



2. Press the [] / [] button to select and set options.

-  [Settings] : Customize the Wi-Fi settings for the camera system.
-  [Station] : Use the Station Mode to connect to a "Personal Hotspot" created by your mobile device.
-  [AP mode] : In AP mode, the camera will act as an access point enabling another Wi-Fi device to connect to it.





Rotate the mode dial to disconnect.

AP mode

This camera may connect with your smart device through Wi-Fi.

Settings of Camera:

1. Select  and press the  button to enter the setting interface.

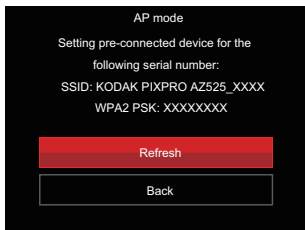

Press the [AF] / [  ]

- Refresh: Create a new WPA2 PSK password
- Back: Back to previous page

Settings of Smart Device:

2. Enable the Wi-Fi of smart device and then search surrounding wireless devices.
3. Select the name of camera SSID to be connected and then input the eight-digit number password after WPA2 PSK on the camera.
4. Click the icon of the APP  to enable the APP.

Set up completion:

5. Once the APP is connected to the camera, functional operations can be enabled on the smart device.