

Vn / Rev.	ECO	Modification	Date	Name
<b>C-ZAM SMASH</b>		1442, chée de Haecht 1130 Brussels Belgium		
INTERFACE GSM		<i>banksys</i>		
GSM/DCS MODULE		File : M:\Projects\WG5\525-549\546.1\Top.sbk		
Draw W. MESKENS	Date : 18/02/03	Sheet / of	Revision	
Approval X. XXXXXXXX	Time : 14:28:36	510-01 / 02	DWG N° : <b>P546150</b>	
Date : XX/XX/2001			-	

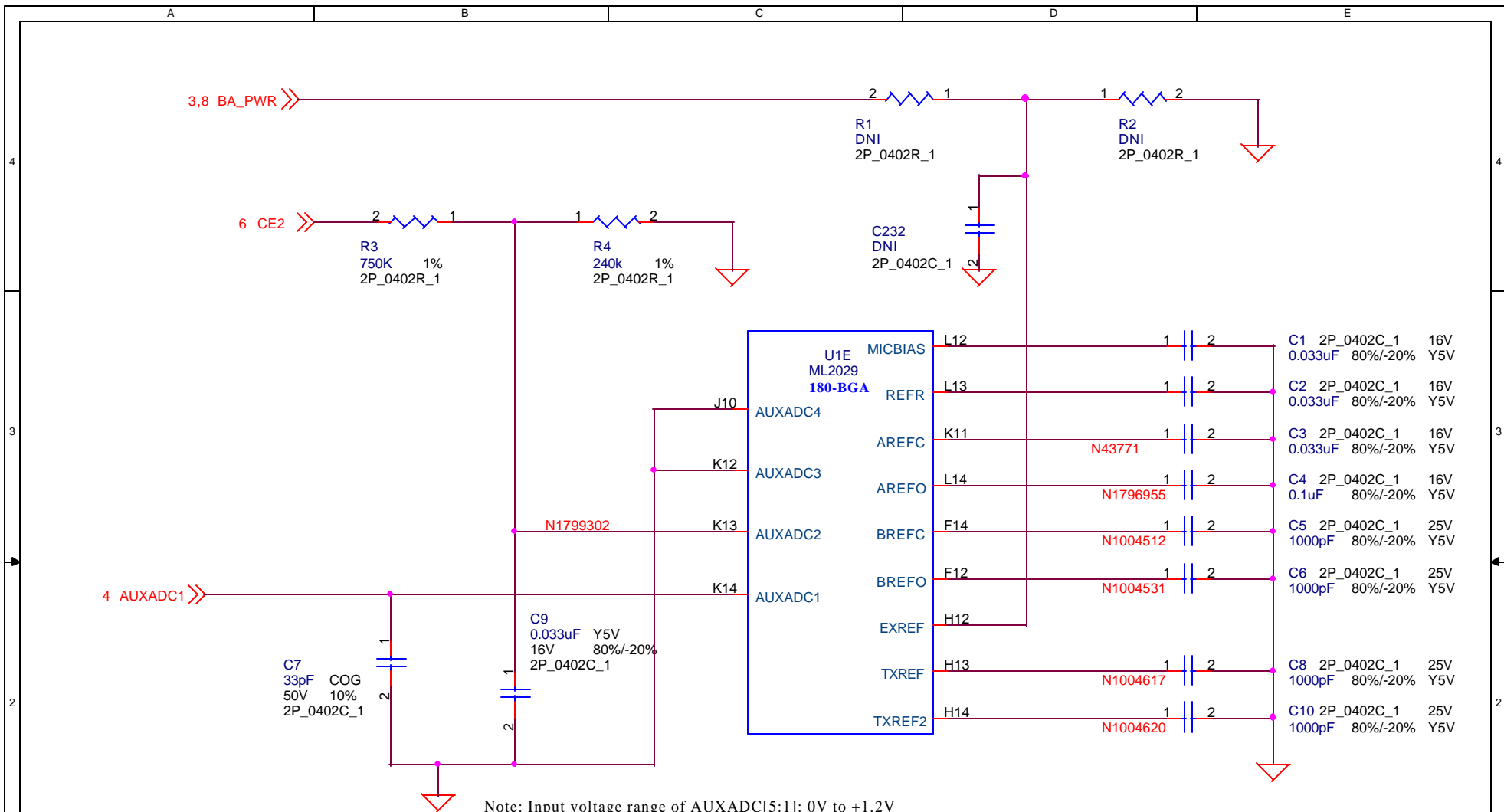

**Table of AUXADC[5:1] Usage**

1. AUXADC1: 32KHz Crystal Temperature
2. AUXADC2: Battery Charge Voltage Level
3. AUXADC3: Battery Charge Current Sense
4. AUXADC4: Battery Charge Temperature Sense
5. AUXADC5: Not Used



Mobilink Telecom  
2710 Walsh Avenue #200  
Santa Clara, CA 95051

Mobilink Proprietary Information  
All rights reserved. This document contains confidential trade secrets and is the proprietary property of Mobilink Telecom, Inc. This document shall not be used, copied, distributed or disclosed without the express written consent of Mobilink Telecom, Inc.

Title		
Analog Voltage References		
Size	Document Number	Rev
A	MTI-3100	6.0
Date:	Wednesday, June 13, 2001	Sheet 1 of 20

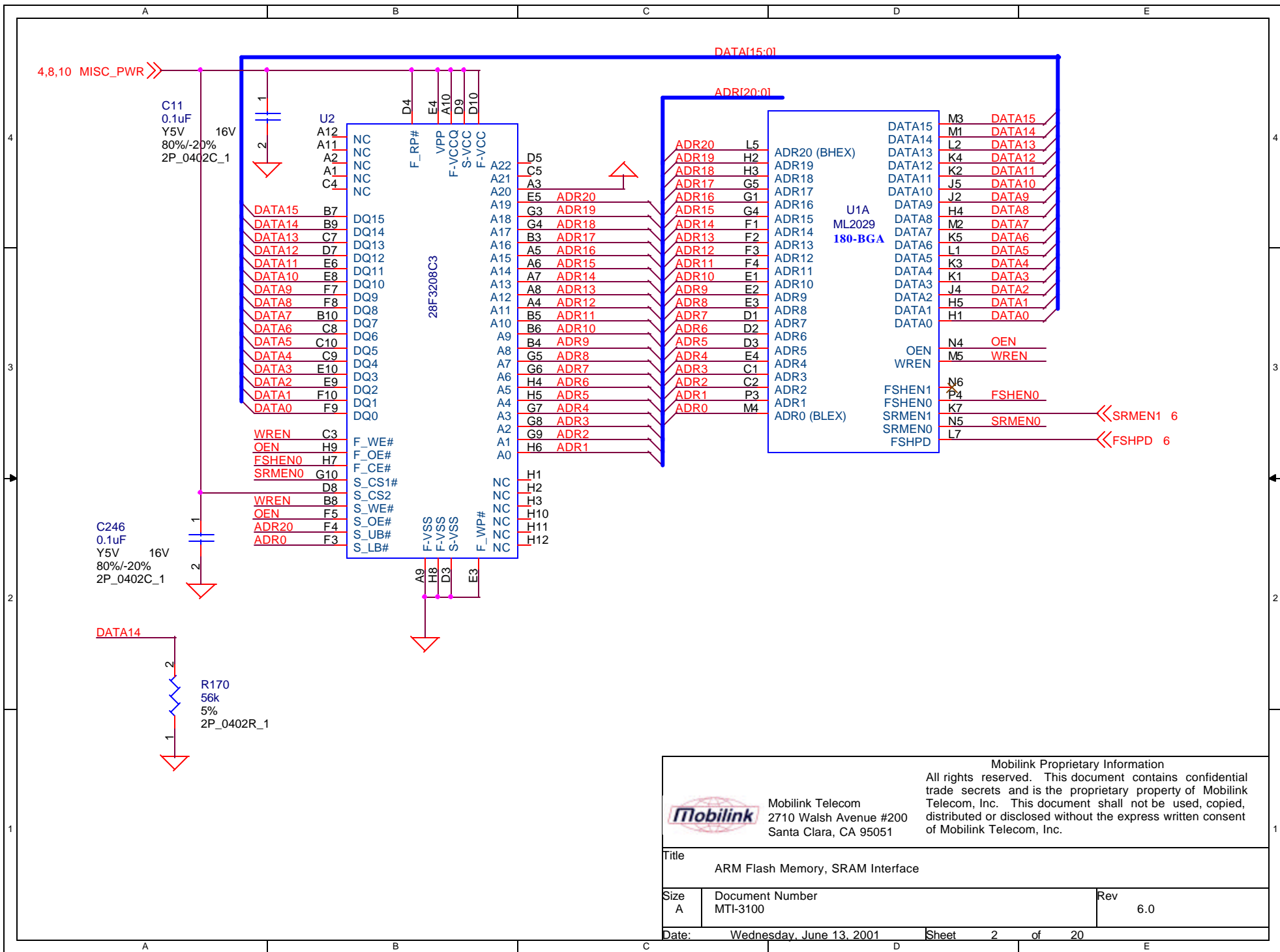

Mobilink Proprietary Information  
All rights reserved. This document contains confidential trade secrets and is the proprietary property of Mobilink Telecom, Inc. This document shall not be used, copied, distributed or disclosed without the express written consent of Mobilink Telecom, Inc.

 Mobilink Telecom  
 2710 Walsh Avenue #200  
 Santa Clara, CA 95051

Title		
ARM Flash Memory, SRAM Interface		
Size	Document Number	Rev
A	MTI-3100	6.0
Date:	Wednesday, June 13, 2001	Sheet 2 of 20

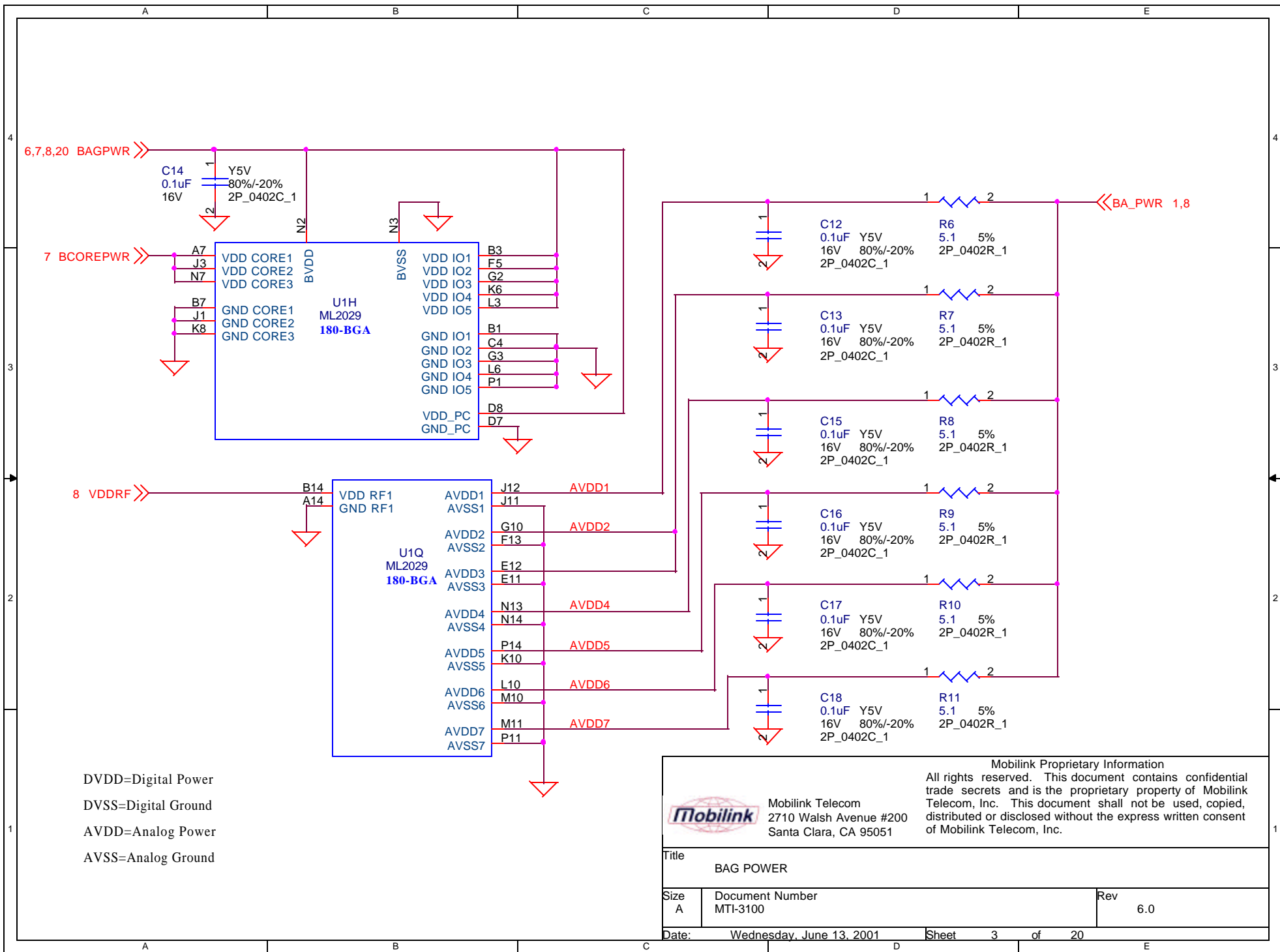



DVDD=Digital Power  
 DVSS=Digital Ground  
 AVDD=Analog Power  
 AVSS=Analog Ground

Mobilink Proprietary Information  
 All rights reserved. This document contains confidential trade secrets and is the proprietary property of Mobilink Telecom, Inc. This document shall not be used, copied, distributed or disclosed without the express written consent of Mobilink Telecom, Inc.

**Mobilink**  
 Mobilink Telecom  
 2710 Walsh Avenue #200  
 Santa Clara, CA 95051

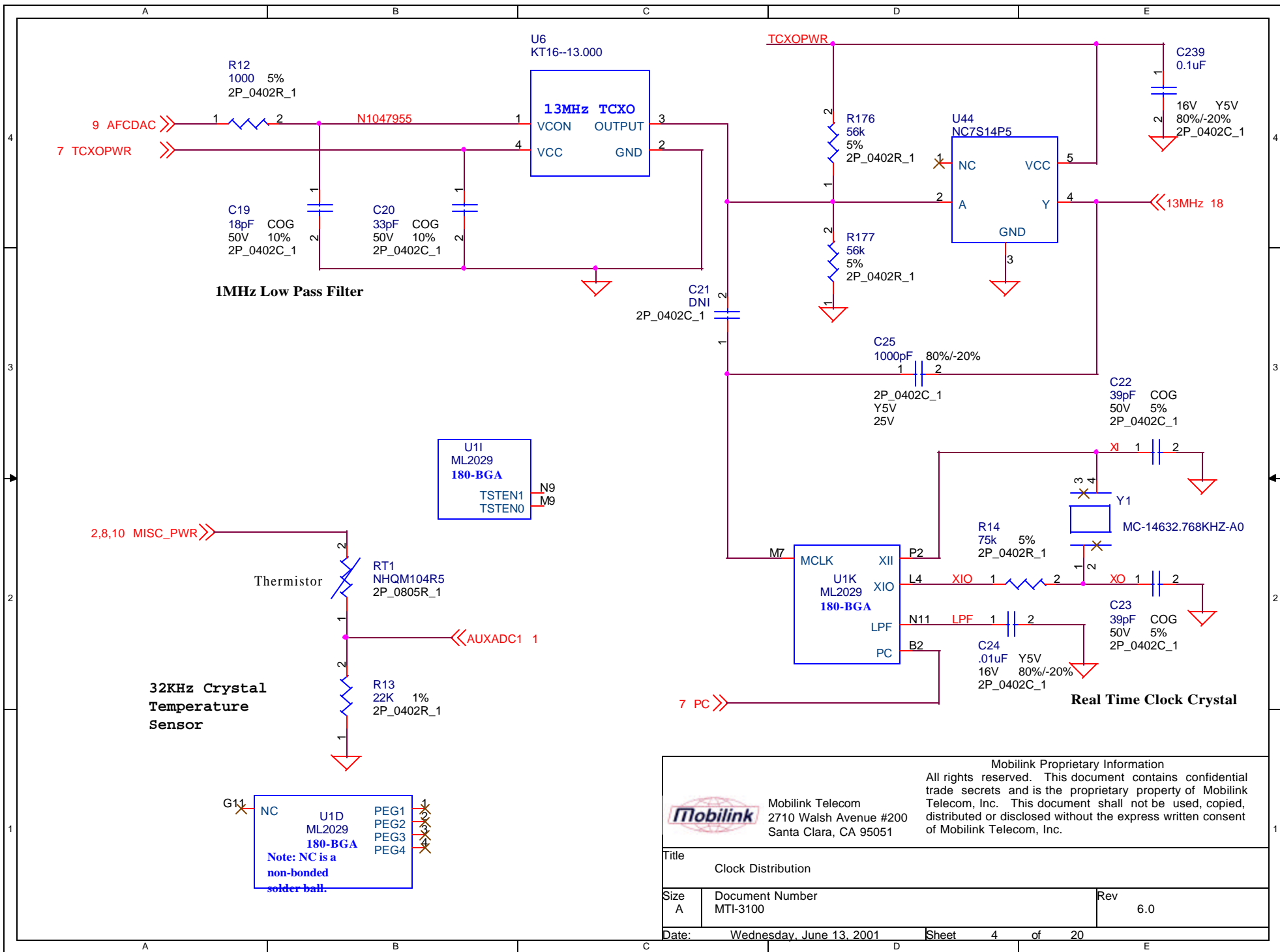
Title BAG POWER		
Size A	Document Number MTI-3100	Rev 6.0
Date: Wednesday, June 13, 2001	Sheet 3	of 20



 Mobilink Telecom 2710 Walsh Avenue #200 Santa Clara, CA 95051		Mobilink Proprietary Information All rights reserved. This document contains confidential trade secrets and is the proprietary property of Mobilink Telecom, Inc. This document shall not be used, copied, distributed or disclosed without the express written consent of Mobilink Telecom, Inc.	
		Title Clock Distribution	
Size A	Document Number MTI-3100	Rev 6.0	
Date: Wednesday, June 13, 2001		Sheet 4	of 20

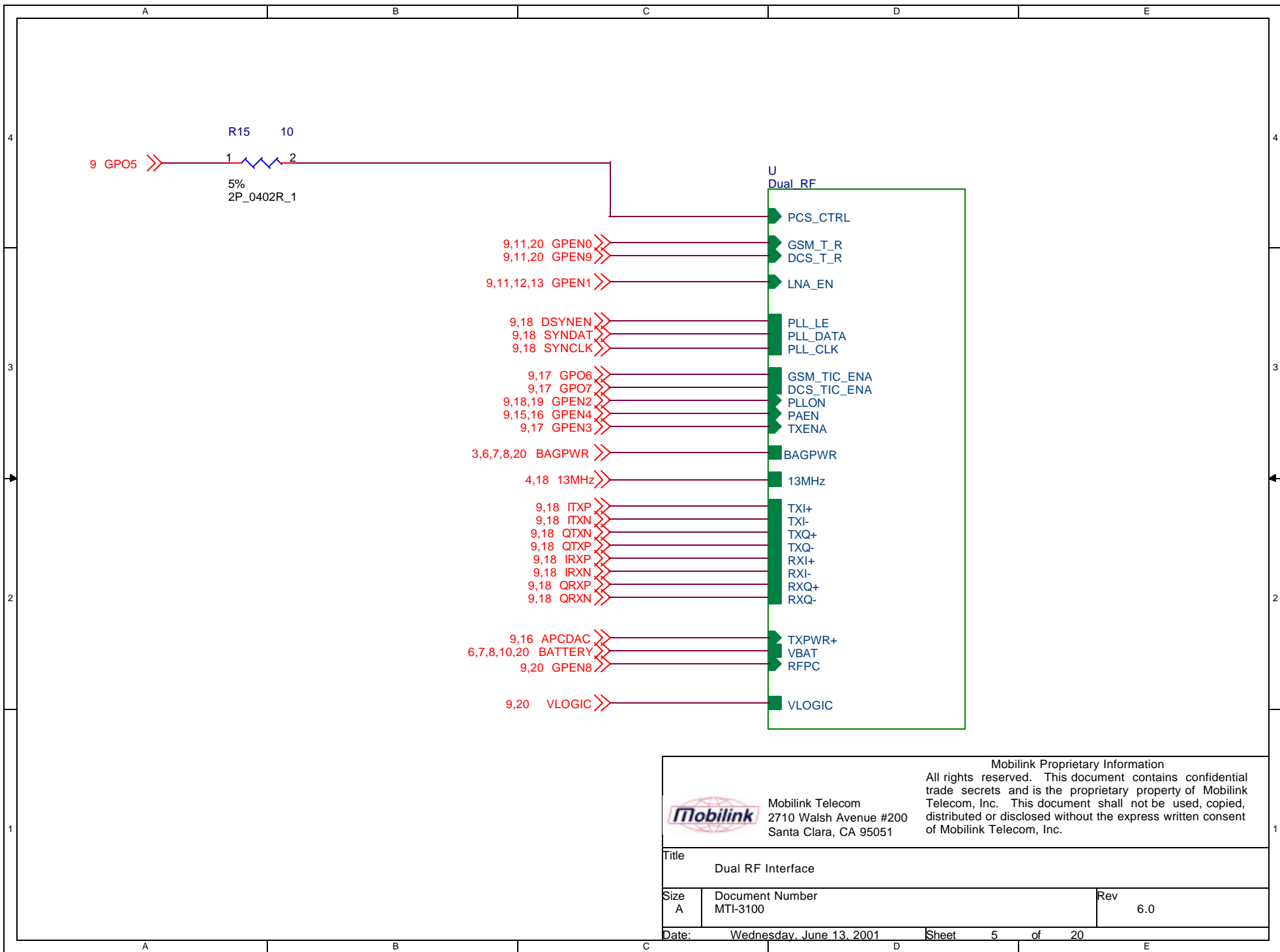

 Mobilink Telecom 2710 Walsh Avenue #200 Santa Clara, CA 95051		Mobilink Proprietary Information All rights reserved. This document contains confidential trade secrets and is the proprietary property of Mobilink Telecom, Inc. This document shall not be used, copied, distributed or disclosed without the express written consent of Mobilink Telecom, Inc.	
		Title Dual RF Interface	
Size A	Document Number MTI-3100		Rev 6.0
Date: Wednesday, June 13, 2001		Sheet 5 of 20	



**+2.1V @ 100mA Voltage Regulator for BAG CORE Power**

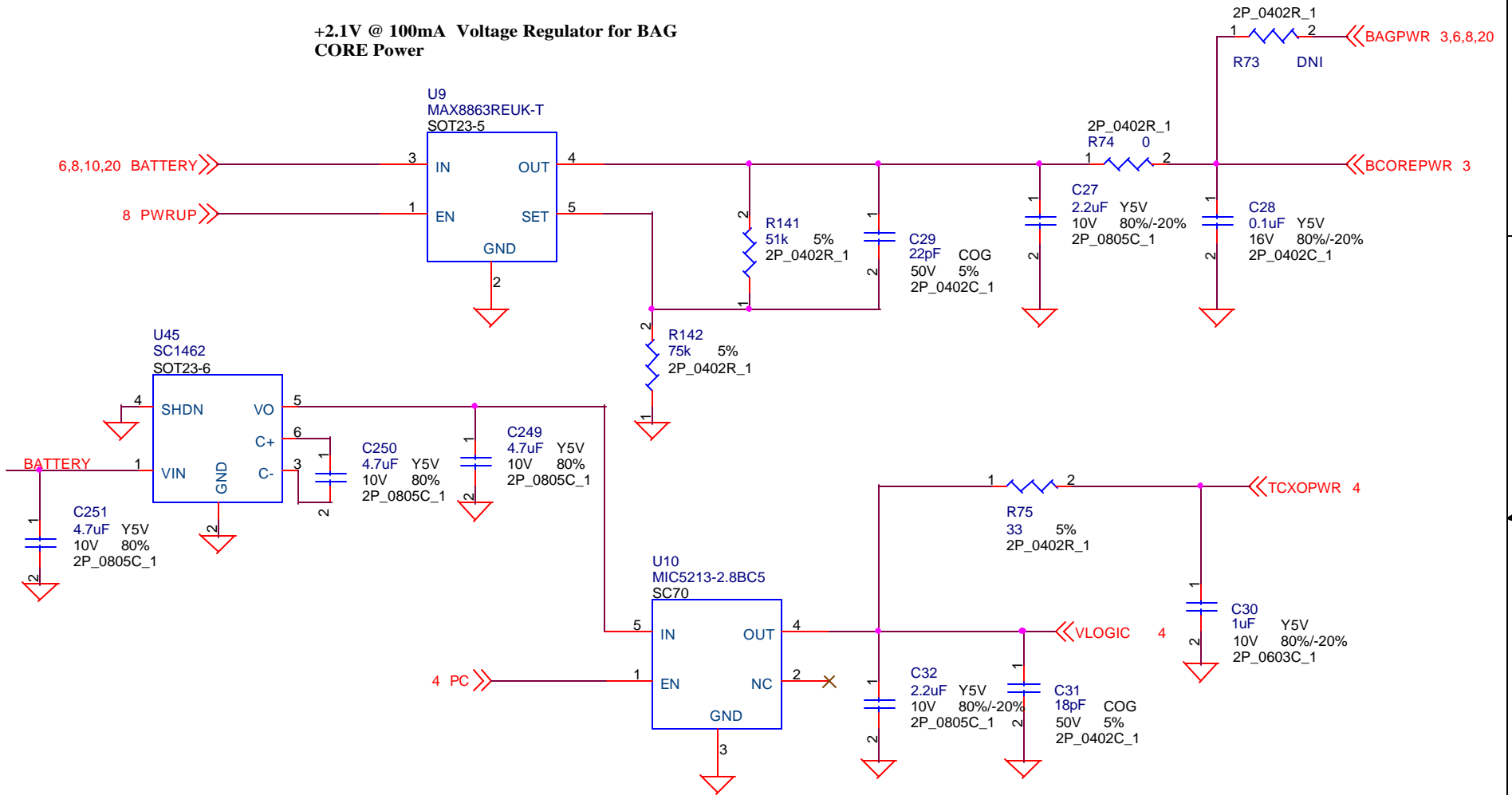

**+2.8V @ 150mA Voltage Regulator for TCXO Power**

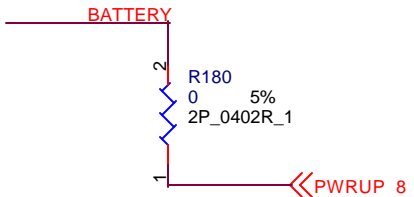

Mobilink Telecom  
2710 Walsh Avenue #200  
Santa Clara, CA 95051

Mobilink Proprietary Information  
All rights reserved. This document contains confidential trade secrets and is the proprietary property of Mobilink Telecom, Inc. This document shall not be used, copied, distributed or disclosed without the express written consent of Mobilink Telecom, Inc.

Title Power Distribution Part 1		
Size A	Document Number MTI-3100	Rev 6.0
Date: Wednesday, June 13, 2001	Sheet 7	of 20



**+2.8V @ 150mA Voltage Regulator for Analog Baseband Power**

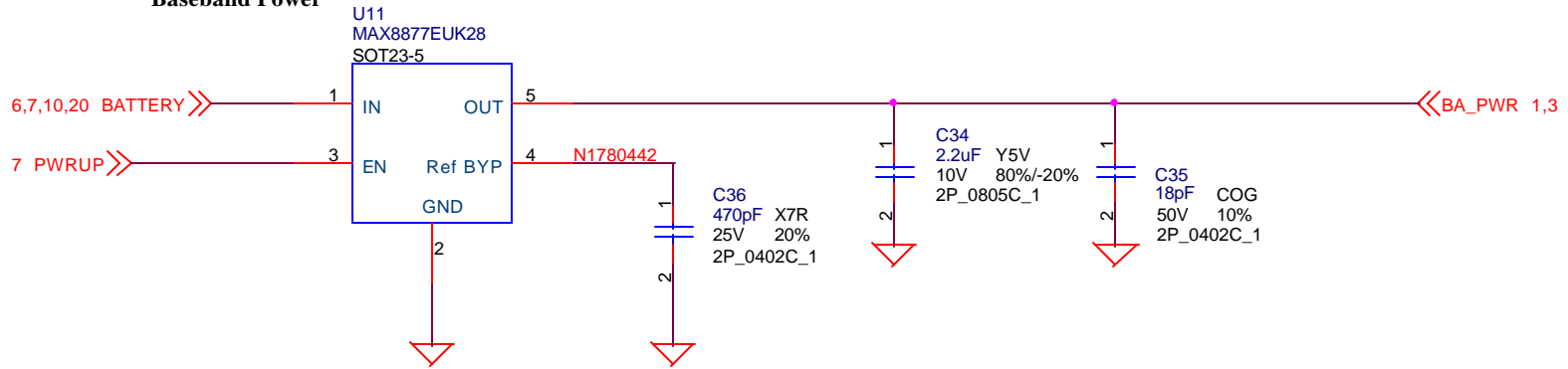

**+2.8V @ 150mA Voltage Regulator for Digital Baseband Power**

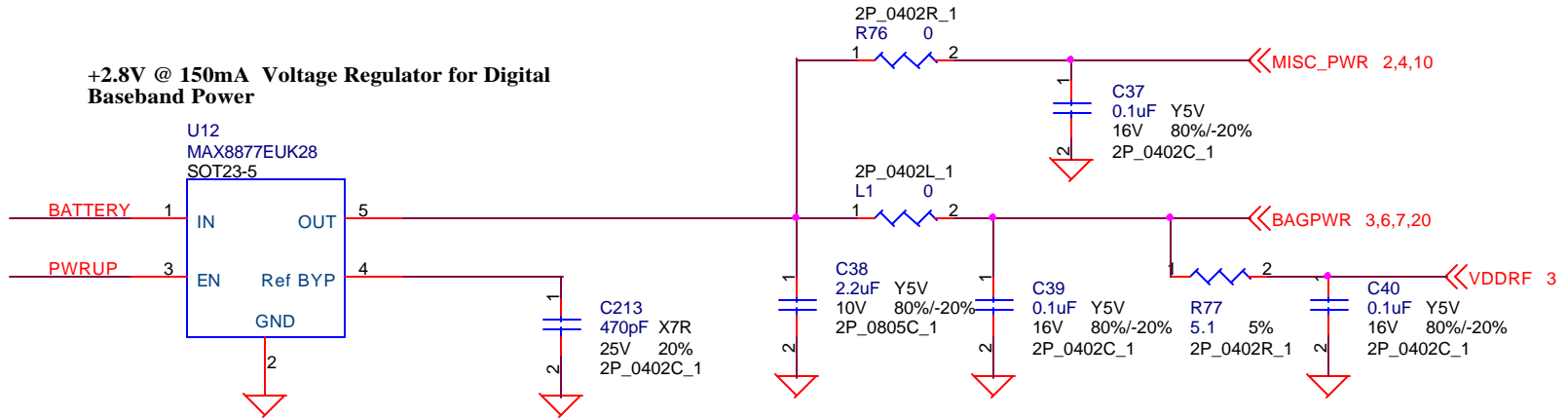

Mobilink Telecom  
2710 Walsh Avenue #200  
Santa Clara, CA 95051

Mobilink Proprietary Information  
All rights reserved. This document contains confidential trade secrets and is the proprietary property of Mobilink Telecom, Inc. This document shall not be used, copied, distributed or disclosed without the express written consent of Mobilink Telecom, Inc.

Title  
Power Distribution Part 2

Size A	Document Number MTI-3100	Rev 6.0
-----------	-----------------------------	------------

Date: Wednesday, June 13, 2001 Sheet 8 of 20

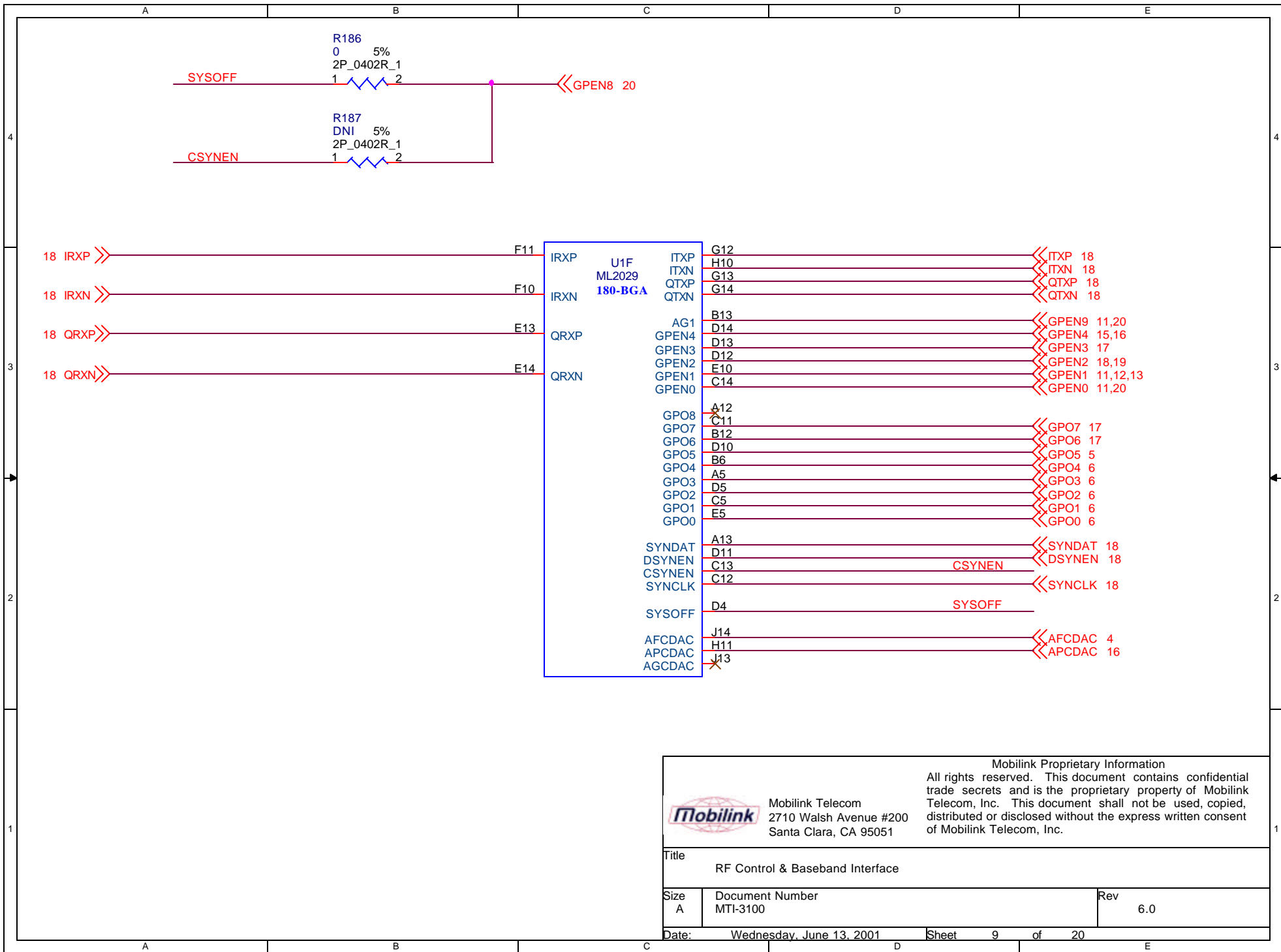

Mobilink Proprietary Information  
All rights reserved. This document contains confidential trade secrets and is the proprietary property of Mobilink Telecom, Inc. This document shall not be used, copied, distributed or disclosed without the express written consent of Mobilink Telecom, Inc.

 Mobilink Telecom  
 2710 Walsh Avenue #200  
 Santa Clara, CA 95051

Title: RF Control & Baseband Interface

Size	Document Number	Rev
A	MTI-3100	6.0

Date: Wednesday, June 13, 2001    Sheet 9 of 20

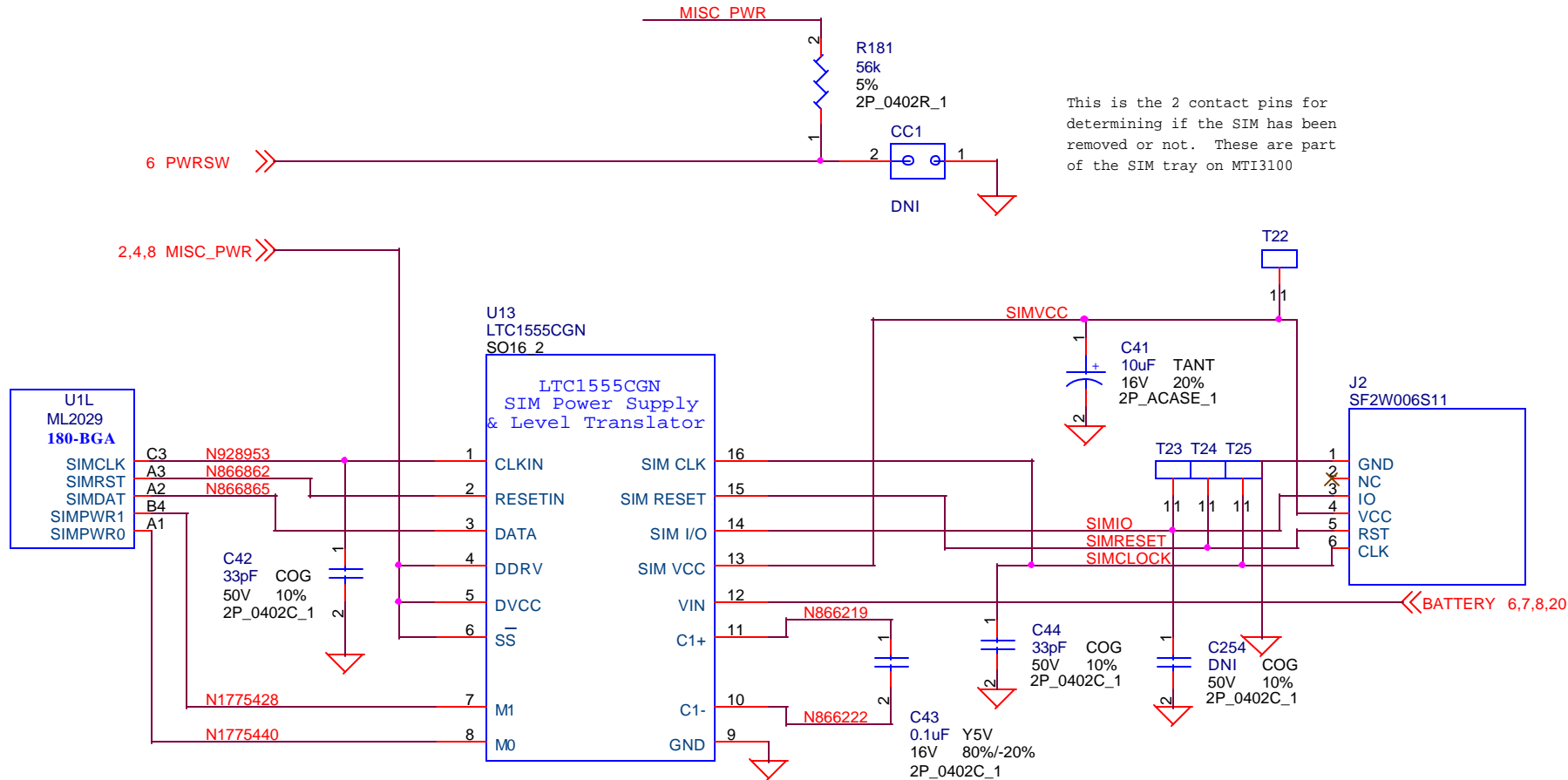

**LTC1555CGN Truth Table**

VIN=+2.7V to +10V @ 60uA to 100uA

M0	M1	Mode
0V	0V	SIM VCC=0V
0V	3V	SIM VCC=VIN
3V	0V	SIM VCC=3V
3V	3V	SIM VCC=5V



Mobilink Telecom  
2710 Walsh Avenue #200  
Santa Clara, CA 95051

Mobilink Proprietary Information  
All rights reserved. This document contains confidential trade secrets and is the proprietary property of Mobilink Telecom, Inc. This document shall not be used, copied, distributed or disclosed without the express written consent of Mobilink Telecom, Inc.

Title		SIM Card Interface	
Size	Document Number	Rev	
A	MTI-3100	6.0	

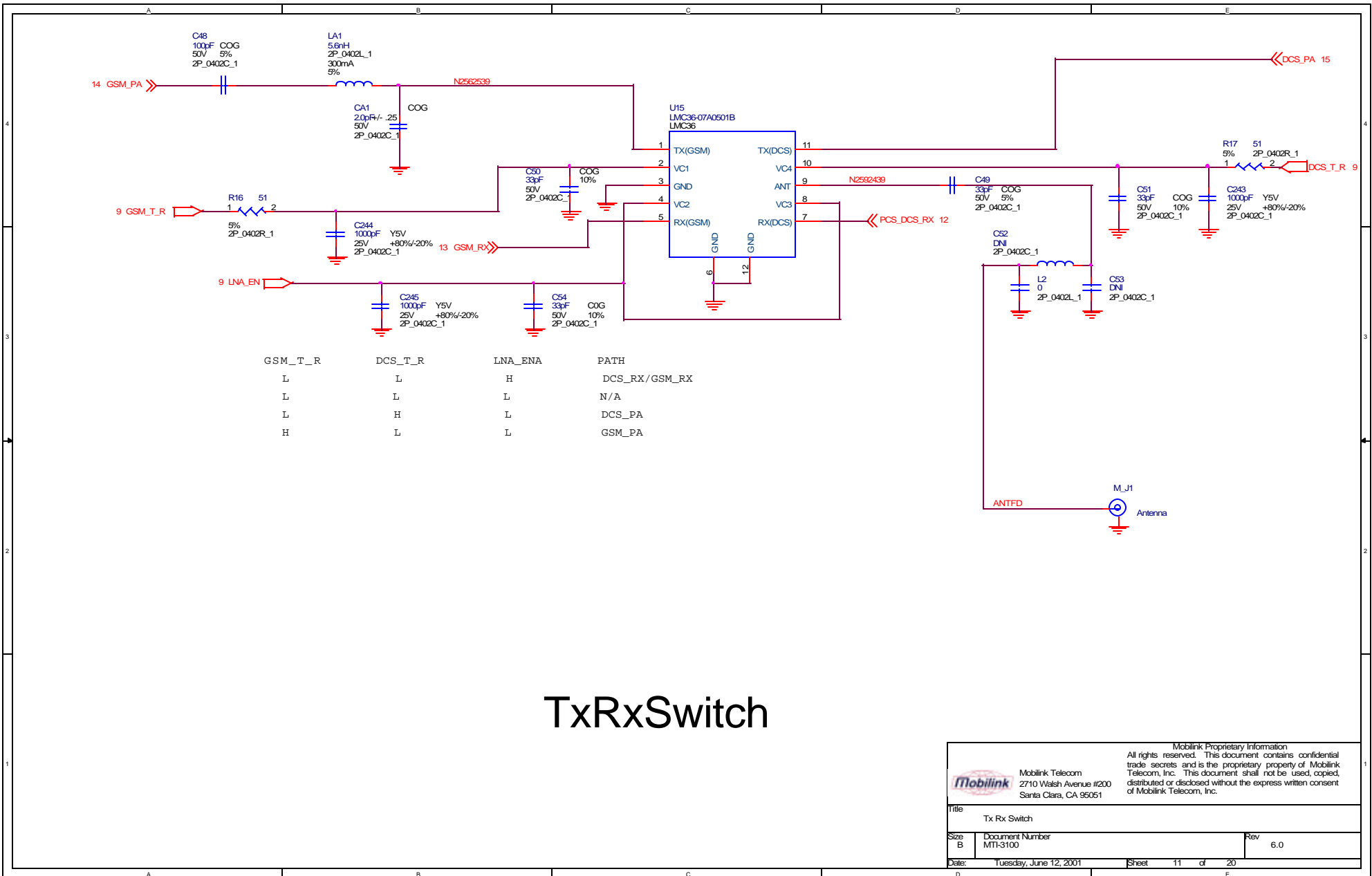

GSM_T_R	DCS_T_R	LNA_ENA	PATH
L	L	H	DCS_RX/GSM_RX
L	L	L	N/A
L	H	L	DCS_PA
H	L	L	GSM_PA

# TxRxSwitch

Mobilink  
 Mobilink Telecom  
 2710 Walsh Avenue #200  
 Santa Clara, CA 95051

Mobilink Proprietary Information  
 All rights reserved. This document contains confidential trade secrets and is the proprietary property of Mobilink Telecom, Inc. This document shall not be used, copied, distributed or disclosed without the express written consent of Mobilink Telecom, Inc.

Title: Tx Rx Switch

Size: B Document Number: MTH-3100 Rev: 6.0

Date: Tuesday, June 12, 2001 Sheet: 11 of 20

# PCS Receiver Front End

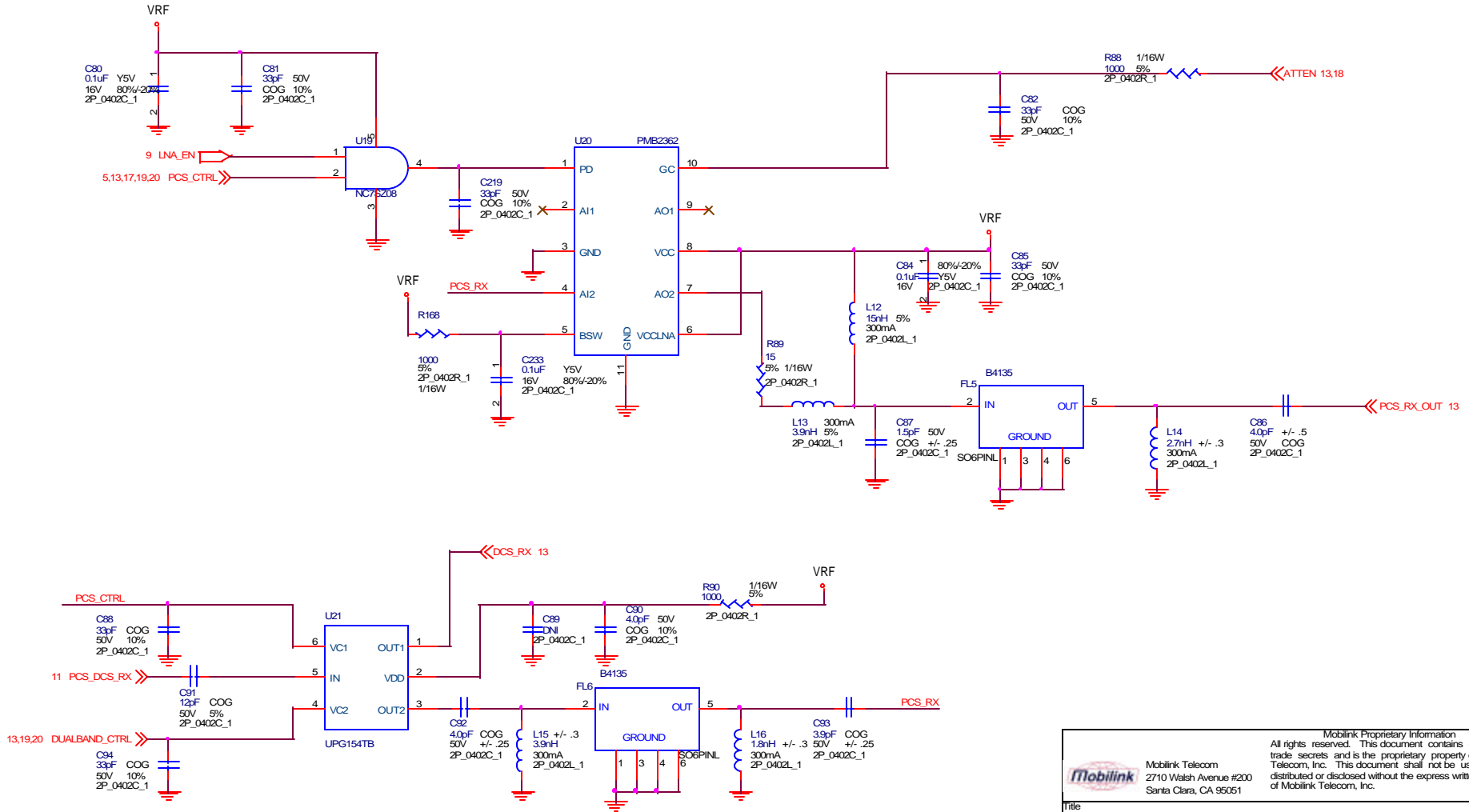

 Mobilink Telecom 2710 Walsh Avenue #200 Santa Clara, CA 95051		Mobilink Proprietary Information All rights reserved. This document contains confidential trade secrets and is the proprietary property of Mobilink Telecom, Inc. This document shall not be used, copied, distributed or disclosed without the express written consent of Mobilink Telecom, Inc.	
		Title: Receiver Front End	
Size: B	Document Number: MTH-3100	Rev: 6.0	
Date: Tuesday, June 12, 2001	Sheet: 12	of 20	

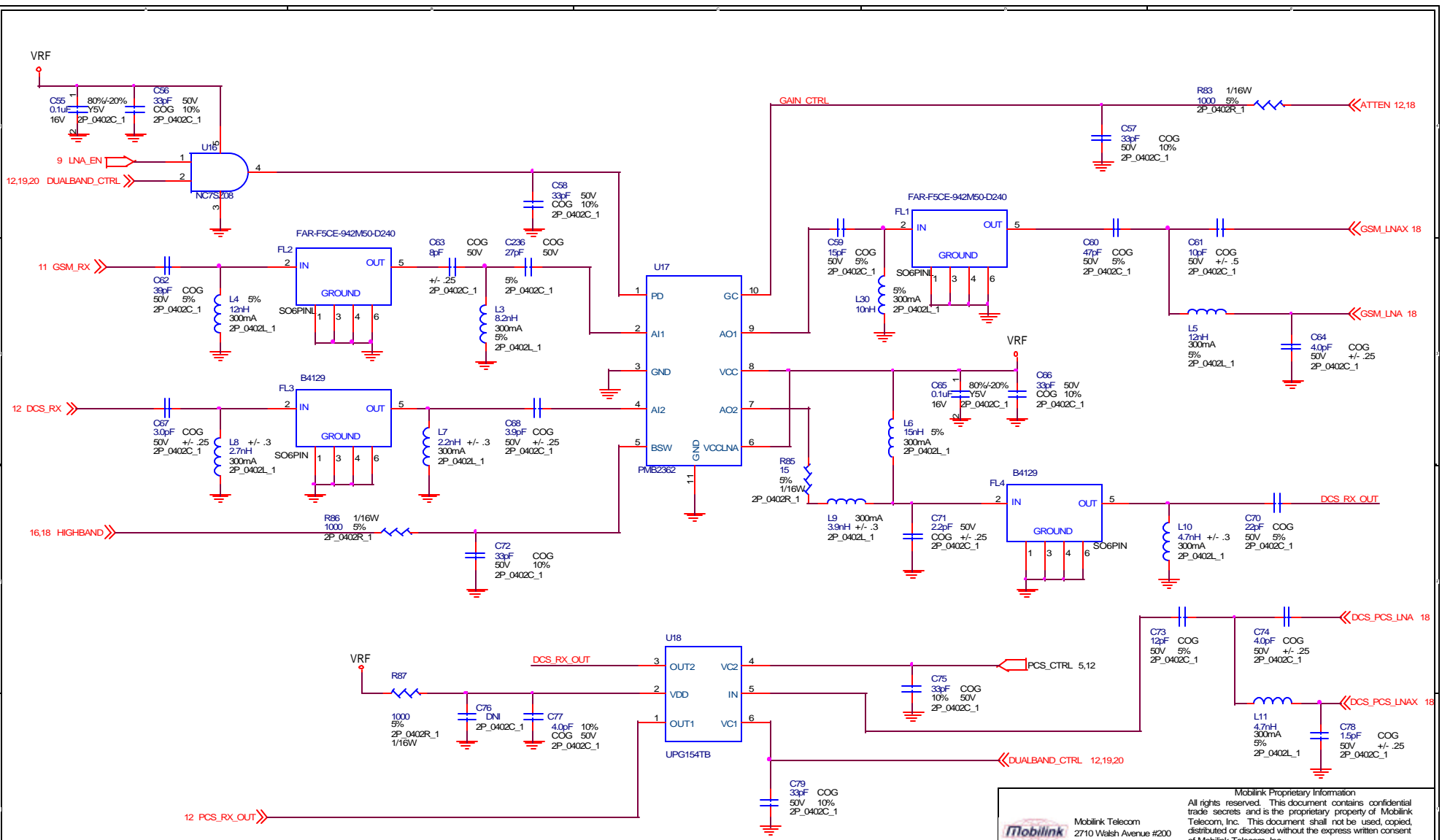

# Dualband Receiver Front End

 Mobilink Proprietary Information All rights reserved. This document contains confidential trade secrets and is the proprietary property of Mobilink Telecom, Inc. This document shall not be used, copied, distributed or disclosed without the express written consent of Mobilink Telecom, Inc.		
Mobilink Telecom 2710 Walsh Avenue #200 Santa Clara, CA 95051		
Title	Receiver Front End	
Size	Document Number	Rev
B	MTI-3100	6.0
Date:	Tuesday, June 12, 2001	Sheet 13 of 20

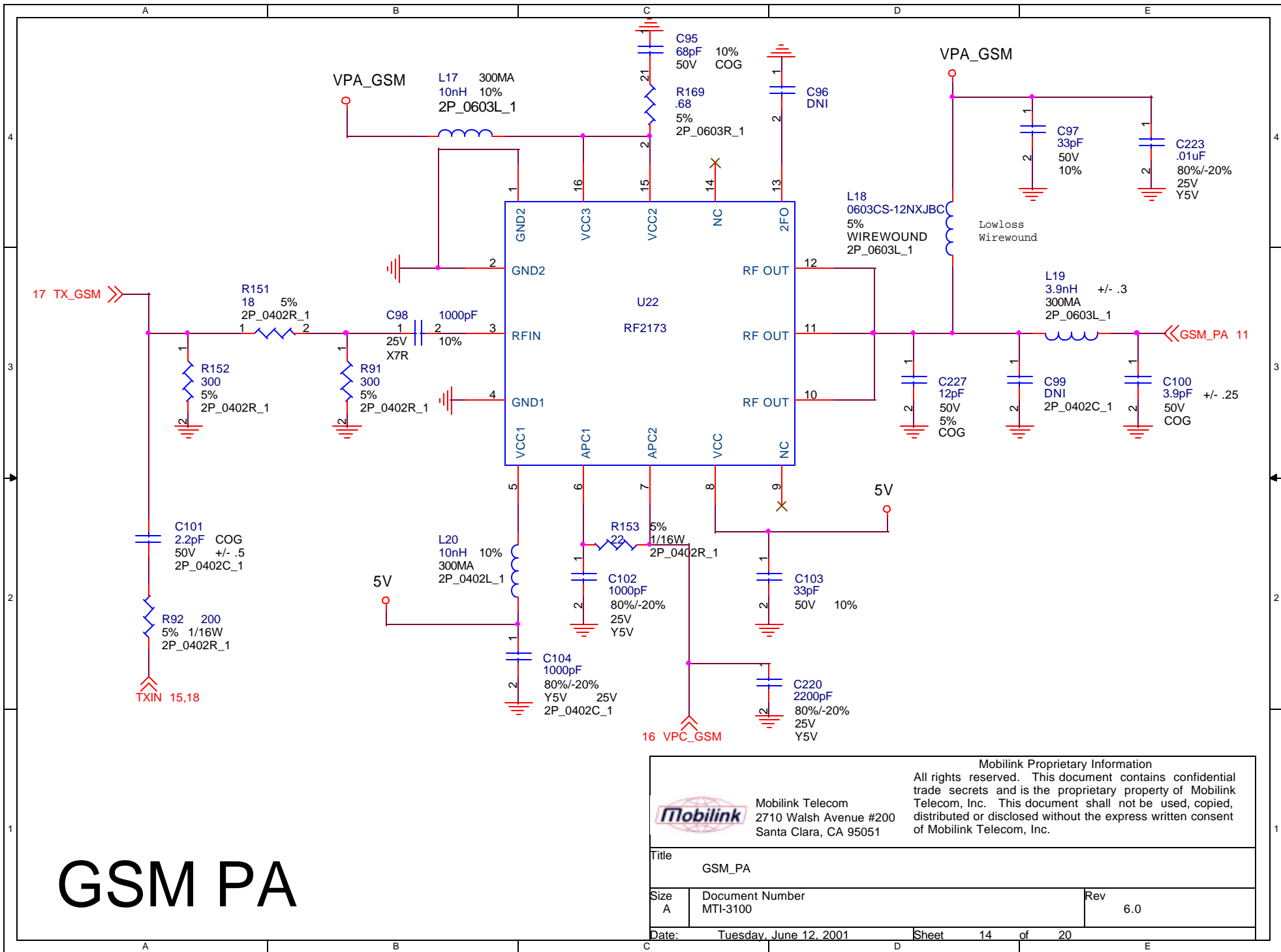

# GSM PA

 Mobilink Telecom 2710 Walsh Avenue #200 Santa Clara, CA 95051		Mobilink Proprietary Information All rights reserved. This document contains confidential trade secrets and is the proprietary property of Mobilink Telecom, Inc. This document shall not be used, copied, distributed or disclosed without the express written consent of Mobilink Telecom, Inc.	
		Title GSM_PA	
Size A	Document Number MTI-3100	Rev 6.0	
Date: Tuesday, June 12, 2001		Sheet 14 of 20	

# DCS PA

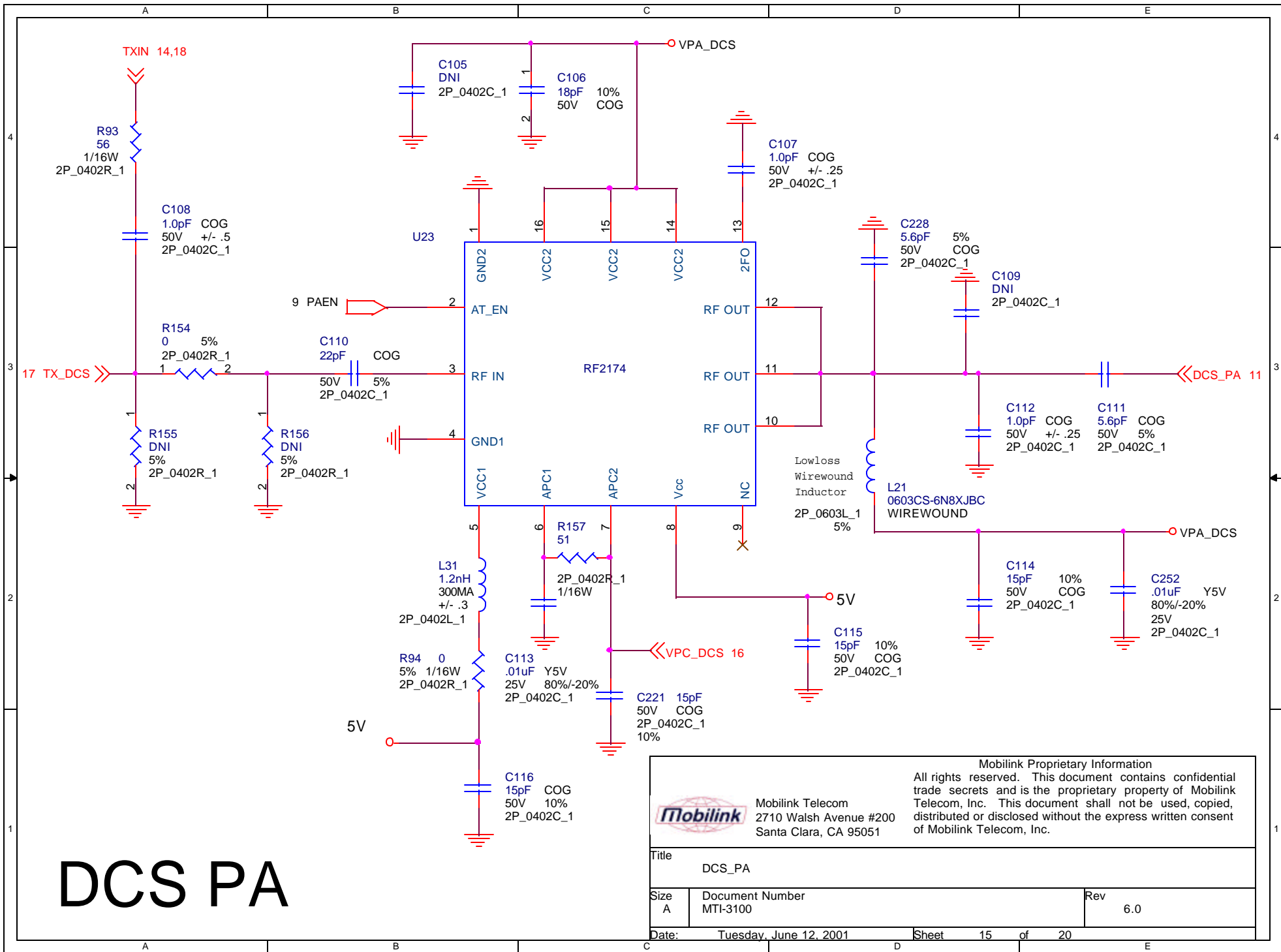

Mobilink Proprietary Information  
 All rights reserved. This document contains confidential trade secrets and is the proprietary property of Mobilink Telecom, Inc. This document shall not be used, copied, distributed or disclosed without the express written consent of Mobilink Telecom, Inc.

**Mobilink**  
 Mobilink Telecom  
 2710 Walsh Avenue #200  
 Santa Clara, CA 95051

Title: DCS\_PA

Size: A	Document Number: MTI-3100	Rev: 6.0
---------	---------------------------	----------

Date: Tuesday, June 12, 2001 Sheet 15 of 20





# TIC VCO

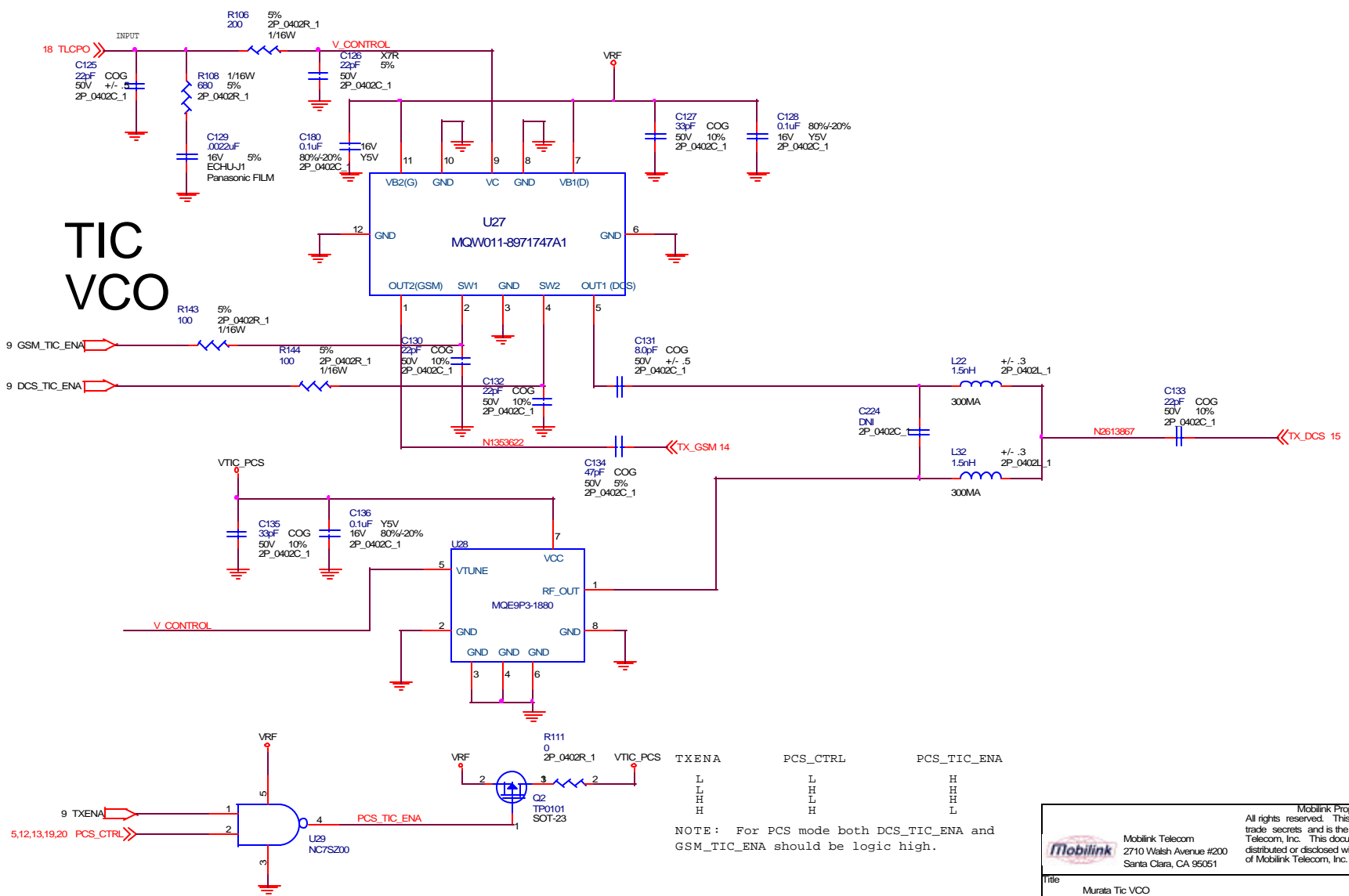

NOTE: For PCS mode both DCS\_TIC\_ENA and GSM\_TIC\_ENA should be logic high.

TXENA	PCS_CTRL	PCS_TIC_ENA
L	L	H
L	L	H
H	L	H
H	H	L

		Mublink Telecom 2710 Walsh Avenue #200 Santa Clara, CA 95051		Mublink Proprietary Information All rights reserved. This document contains confidential trade secrets and is the proprietary property of Mublink Telecom, Inc. This document shall not be used, copied, distributed or disclosed without the express written consent of Mublink Telecom, Inc.	
		Title: Mublink Tic VCO			
Size B	Document Number MTH-3100			Rev	6.0
Date:	Tuesday, June 12, 2001	Sheet	17	of	20



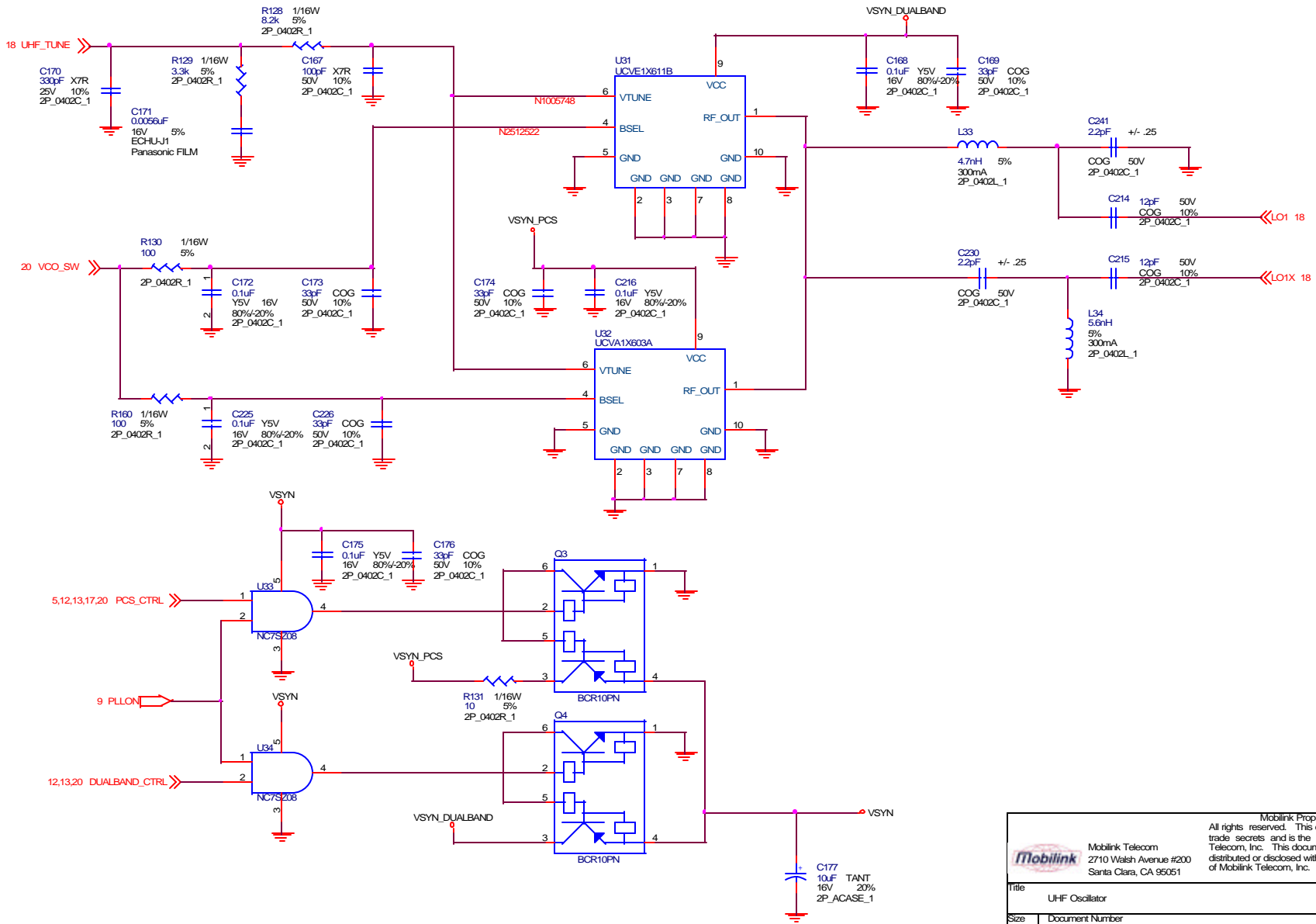

		Mobilink Telecom 2710 Walsh Avenue #200 Santa Clara, CA 95051		Mobilink Proprietary Information All rights reserved. This document contains confidential trade secrets and is the proprietary property of Mobilink Telecom, Inc. This document shall not be used, copied, distributed or disclosed without the express written consent of Mobilink Telecom, Inc.	
		Title: UHF Oscillator			
Size B	Document Number MTH-3100			Rev 6.0	
Date:	Tuesday, June 12, 2001	Sheet	19	of	20

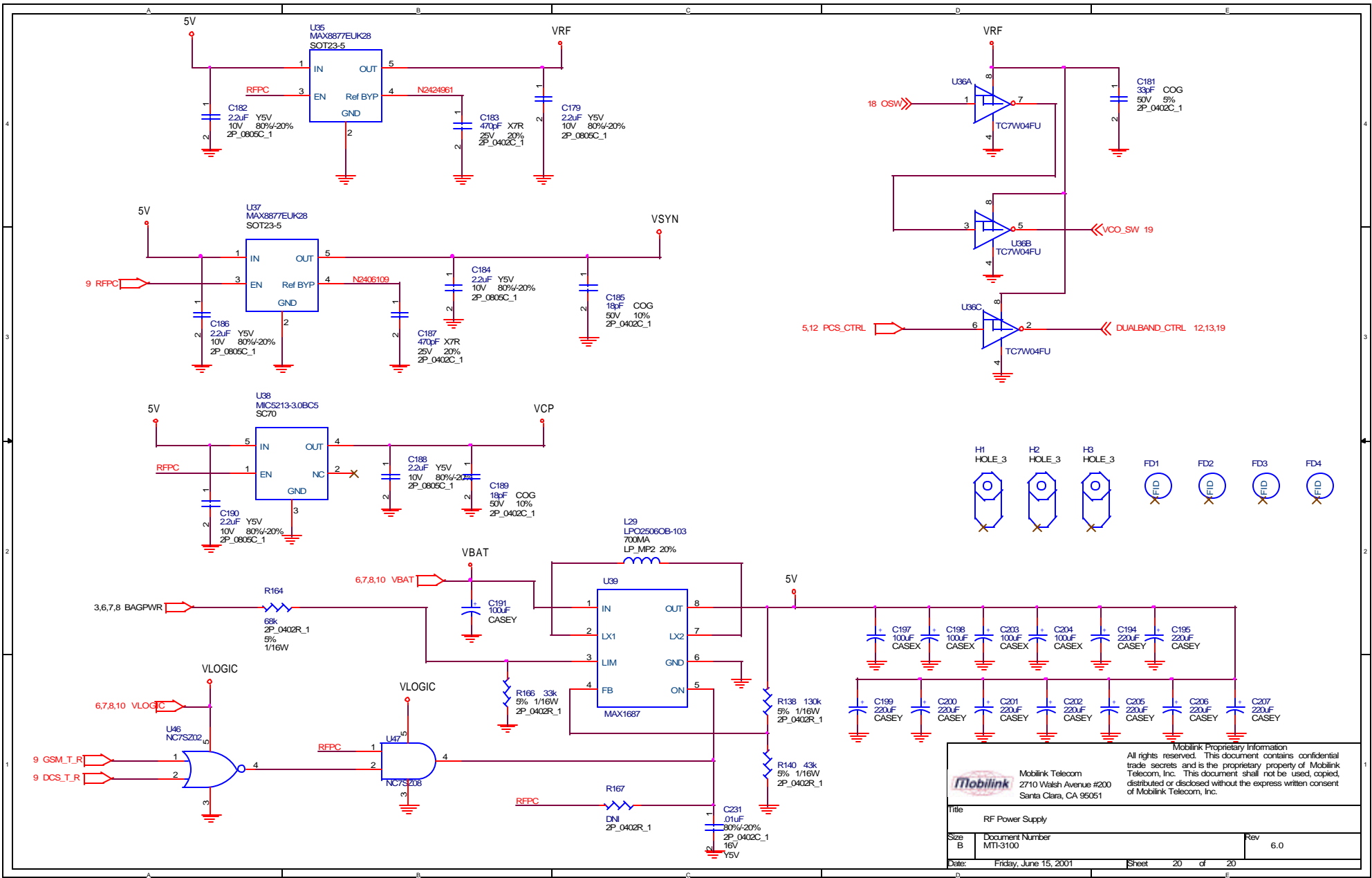

		Mobilink Telecom 2710 Walsh Avenue #200 Santa Clara, CA 95051	
		Mobilink Proprietary Information All rights reserved. This document contains confidential trade secrets and is the proprietary property of Mobilink Telecom, Inc. This document shall not be used, copied, distributed or disclosed without the express written consent of Mobilink Telecom, Inc.	
Title: RF Power Supply			
Size: B	Document Number: MTH-3100	Rev: 6.0	
Date: Friday, June 15, 2001	Sheet: 20	of 20	