



# *V4™ Installation/User Guide*

REV: 04/06/18



## Contents

Introduction .....	5
System Overview .....	6
Installation Checklist .....	7
V4 Equipment .....	8
General Guidelines.....	9
Layout.....	9
Electrical.....	9
Drill Holes .....	10
Cable Management .....	10
Cable Management Examples .....	10
General Housekeeping.....	11
V4 Mounting Plate and Unit .....	11
Mounting Areas .....	12
Mounting Considerations .....	12
Orientation and Placement .....	13
V4 Pin Configuration .....	14
Power/Data Cables.....	14
4 Pin, 3 Wire Power Cable .....	15
Light Duty Power/Data Cable .....	16
To install the light duty cable: .....	16
<b>V4™ Installation/User Guide</b>	<b>2</b>

9 Pin Diagnostic 500K Cable .....	17
2-Pin Deutsch 500K Cable (Backbone) .....	18
4 Pin, 4 Wire Power Cable .....	18
4 Pin Testing and Cable Management.....	19
Power Bundle Wiring – 4 Pin.....	19
Using a Digital Multimeter (DMM) Probe for Testing 4 Pin Cable.....	20
Wiring Guidelines .....	21
Fuse Taps Installation .....	21
Poke and Weave Installation .....	21
External GPS Antenna (Optional) .....	23
<i>Optional</i> GPS Antenna Adhesive Tag (for non-magnetic mounting surfaces).....	23
GPS System Check .....	24
Check the LEDs.....	24
Turn Key Off.....	25
Turn to Accessory Position .....	25
System Checklist .....	26
System Specifications.....	27
Electrical.....	27
Environmental.....	27
GNSS Receiver .....	27
Cellular.....	27



---

External GPS Antenna ( <i>optional</i> ) .....	27
V4 and Mount Dimensions .....	28
Typical Installation.....	29
Installation Example .....	30
System Installation .....	31
Zonar Discrete Input System .....	32
Warranty .....	33
Notices .....	34
Legal Information.....	35



## Introduction

Zonar equipment will provide years of reliable service if properly installed and maintained. Zonar equipment is typically installed in heavy vehicle applications and is often subjected to extreme temperatures, dust, dirt, vibration, and shock. Proper installation is the critical first step to equipment longevity and optimal performance.

This guide is meant to be a general guideline for the professional installer and technician. While we attempt to point out the most common installation questions and issues, common sense, good housekeeping procedures, attention to detail, safety adherence, and technical competence of the professional installer are critical for a successful installation.

Please refer to your specific vehicle manufacturer guidelines for the installation of electrical components and wiring.

Details on operating the V4 and its built-in applications and software are given in this guide.

A professional team of Zonar support technicians and engineers are available to answer your installation questions. Contact Zonar at 1-877-843-3847 or by email at [customercare@zonarsystems.com](mailto:customercare@zonarsystems.com).

## System Overview

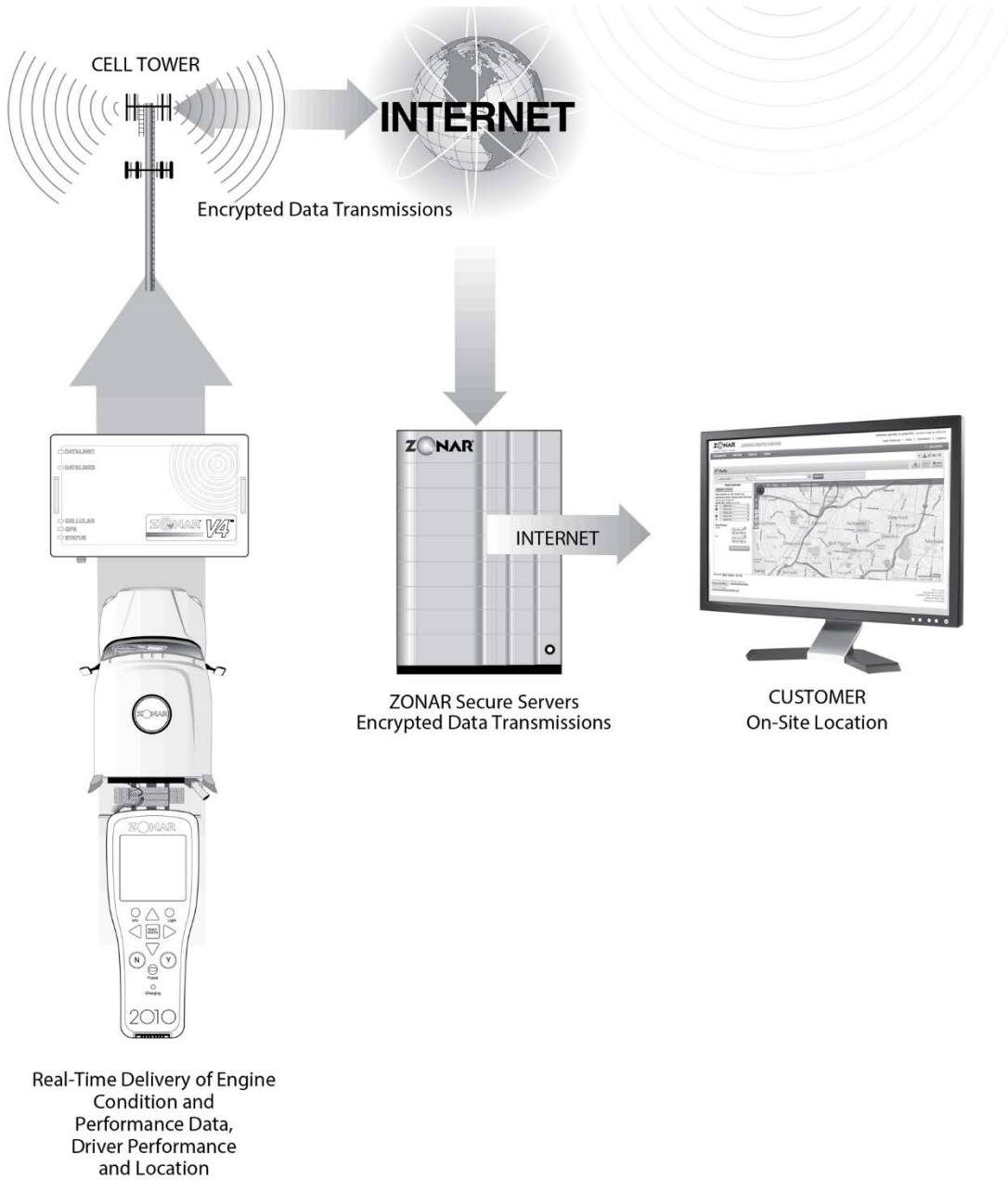

## Installation Checklist

The following is an installation checklist broken down by task.

Task #	Task	Required?	Page #	Complete?
1	Inventory all <a href="#">V4 equipment</a>	Required	8	
2	Layout all cables and accessories according to:	Required	-	
3	- <a href="#">General guidelines</a>	Required	9	
4	- <a href="#">V4 device and mounting plate instructions</a>	Required	11	
5	- <a href="#">Power / Data cables instructions</a>	Required	14	
6	- <a href="#">External GPS Antenna guidelines</a>	If used	23	
7	- <a href="#">Discrete input system instructions</a>	If used	32	
8	Disconnect vehicle battery ground cable	Suggested		
9	<a href="#">Install V4 Power / Data cable</a> . Do not connect 4 Pin connector to V4 at this time. Do not connect OBDII connector to vehicle at this time (If used)	Required	14	
10	<a href="#">Install Discrete Input cable</a>	If used	32	
11	<a href="#">Install external GPS antenna</a>	If used	23	
12	<a href="#">Install V4 mount plate &amp; V4</a>	Required	11	
13	Interconnect all cables & wires to V4 (except 4 pin power)	Required	14	
14	Reconnect vehicle battery ground cable	Suggested	-	
15	<a href="#">Connect 4 pin power cable to V4</a>	Required	14	
16	Start engine	Required	-	
17	<a href="#">Connect OBDII connector to vehicle</a> (if used)	Required	14	
18	Complete <a href="#">V4 System functional checkout &amp; checklist</a>	Required	24	
19	Shutdown engine	Required	-	

## V4 Equipment

- A. V4 GPS Unit
- B. V4 Mounting Plate and Mounting Screws (Provided)
- C. GPS Antenna (Optional)
- D. GPS Antenna Adhesive Tag (Optional - used for non-magnetic rooftop GPS Antenna installs)

**Note:** See [External GPS](#) for detailed information on GPS antenna requirements and recommendations.

**A**



**C**



**B**

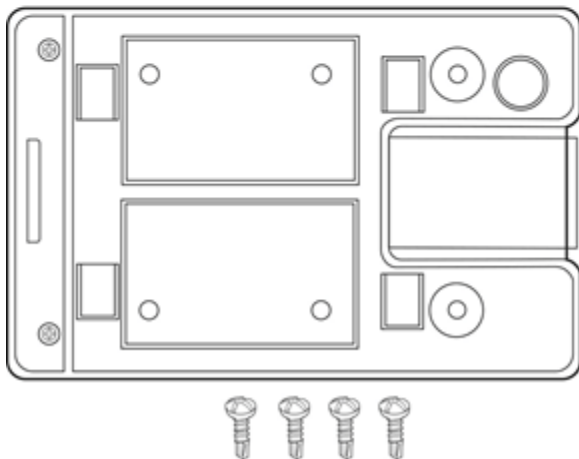

**D**





## General Guidelines

The following is list of general guidelines for the installation process. It is important to read these before starting.

### Layout

- V4 unit must be located a minimum of 25 cm (10 inches) from any person.
- Do not place Zonar RFID tags, cables, or other equipment in any location or position which may compromise human or equipment safety.
- Verify placement acceptability with State DOT/Law enforcement prior to installation.
- V4 has a temperature range of -40 °C (-40 °F) to +85 °C (+185 °F). Do not mount V4 in hot engine compartments or near hot exhaust components.
- Lay all components out prior to installation to check for proper cable length and interference issues.
- Avoid mounting Zonar equipment, antennas and wiring near other radio equipment (for example, two-way radios), PA equipment and high energy electrical sources (for example, cables, relays, amplifiers, etc.).

### Electrical



- **Consult the vehicle's manufacturer for specific installation guidelines. (HIGHLY RECOMMENDED for Multiplex electrical systems)**
- All power leads (red and white) must be connected to the vehicle's protected circuitry (for example, fuse panel, circuit breaker panel, protected circuits). Never electrically connect Zonar equipment to unprotected circuits (for example, directly to battery).
- It is also required that all power leads (red and white) be protected with a 3 to 5 amp fuse and inline fuse holder (included) for optimal system protection.
- Electrical fuses should be installed as close as possible to the source of power.
- Do not connect to the 4 pin power input until all other V4 cables have been connected.

## Drill Holes

- Do not drill into the V4 unit. This will void the warranty.
- Capture all drill chips during drilling operations. Do not allow chips to fall onto equipment, furnishings, etc.
- Deburr all drill holes on both sides of drilled surface. The following is an example of a deburr tool:



- All drill holes must have a rubber grommet or similar anti-chaffing system installed to protect cable assemblies (e.g. plastic conduit).
- Seal all penetration drill holes which may pass rain water.

## Cable Management

- Strain relieve and support all cable installations.
- Avoid sharp bends and tight radius installations of cables.
- Avoid moving components (for example, doors, steering shafts, handles, fans, etc.).
- Provide enough cable slack to allow for servicing of equipment (adequate service loop)
- Avoid routing cables through doors, windows, and other pinch points.
- Avoid routing cables in high personnel traffic areas.
- Avoid routing antenna cables near radio and PA equipment.

## Cable Management Examples

### CORRECT



- Bend radius is adequate.
- Hole has grommet.

### INCORRECT



- Bend radius is too tight.
- Hole has sharp edges.
- Hole has no grommet.

## General Housekeeping

1. Capture all drill chips during drilling operations. Do not allow drill chips to fall onto electrical equipment, furnishings, heating ducts, etc. Magnets, sticky tape, vacuums, physical barriers, etc. may all be used to accomplish this task.
2. Remove excess sealant. Sealant should be debris and contaminant free (for example, no drill chips), consistent, and uniform in appearance.
3. Clip excess wire tie protrusions.

## V4 Mounting Plate and Unit

To comply with FCC RF exposure requirements for mobile transmitting devices, this device must be installed to provide a separation distance of at least 25 cm (10 inches) from all persons. See [General Guidelines](#).

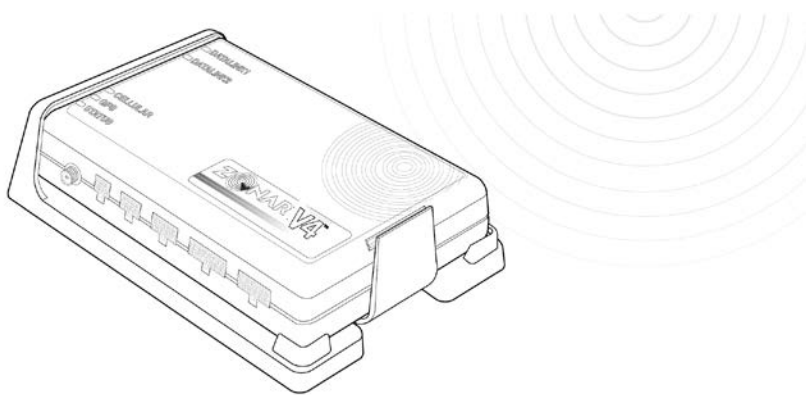

The installation technician must record which V4 unit is being installed in each vehicle.

1. Find the GPS ID # on the back of the unit labeled “GPSID (S/N) 18xxxxxx.”
2. Record the asset (vehicle name) and the GPS being installed—this is important information for Zonar Customer Care or the Ground Traffic Control Administrator.



## Mounting Areas

Mount onto an interior flat surface that is large enough to accommodate the footprint. Suggested mounting areas include the following:

- Horizontal mount on dashboard under an angled windshield free of metallic obstructions
- Overhead compartment mount with a clear non-metallic view of the sky (for example, under a fiberglass roof or fairing).

**Note:** Verify placement acceptability with state DOT/law enforcement prior to installation. Enclosed areas require an external GPS.

## Mounting Considerations

- Avoid mount areas with difficult access or areas that do not allow for direct diagnostic LED viewing.
- Do not mount near other radio equipment such as two-way radios, PA equipment and high energy electrical sources (e.g., cables, relays, amplifiers, etc.).
- Avoid dirty, dusty, or damp mount areas (for example, near floors and entry ways).
- To prevent water damage, do not install below windows or doors that open to the vehicle's exterior.

**Note:** If enclosing in a radio-shielded area (for example, metallic enclosure) an external GPS antenna may be necessary for proper operation and performance.

## Orientation and Placement

### Orientation and Placement:

- 1) Horizontal with clear (non-metallic) view of sky
- 2) Zonar logo towards sky

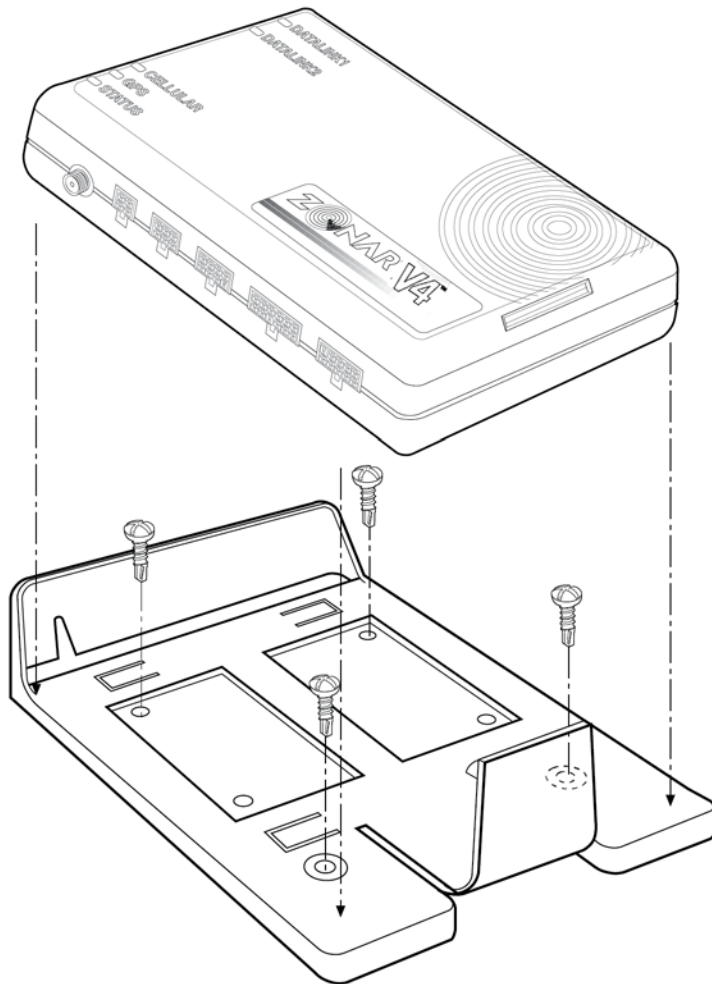

## V4 Pin Configuration

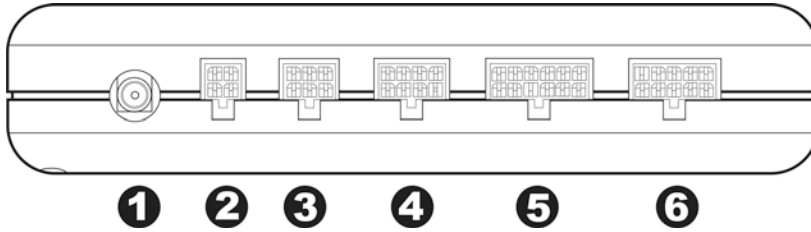

1. External GPS antenna (Optional)
2. 4 Pin Power Input (Disconnect first, Reconnect last)
3. 6 Pin Accessory Port: Z Pass™/Operator ID
4. 8 Pin for 2010/2020/Connect Dock
5. 12 Pin Discrete Input (Optional)
6. 10 Pin ECM input (SAE J1708/J1939 & OBDII equipped vehicles)

## Power/Data Cables

The V4 has the following primary cables for connecting to the vehicle electrical and data system:

- 4 Pin, 3 Wire Power Cable (Part# 10007)
- Light Duty (LD) Power Cable (Part# 81008 with LD Breakout Part# 80999)
- 9 Pin Diagnostic 500K Cable (Part# 81523) with optional 6-9 pin adapter (Part# 81632)
- 2 Pin Deutsch 500K Cable (Part# 81517)

Additionally, there is a fifth uncommon cable specifically used to wire around battery disconnect systems: 4 Pin, 4 Wire power cable (Part# 10030).

See [General Guidelines](#) before you begin. Do not connect to the 4 pin power input until all other V4 cables have been connected.

## 4 Pin, 3 Wire Power Cable

Use this cable for equipment that does not have OBDII, SAE J1708/J1587 or SAE J1939 data buses. For wiring procedures see [4 Pin Testing and Cable Management](#).

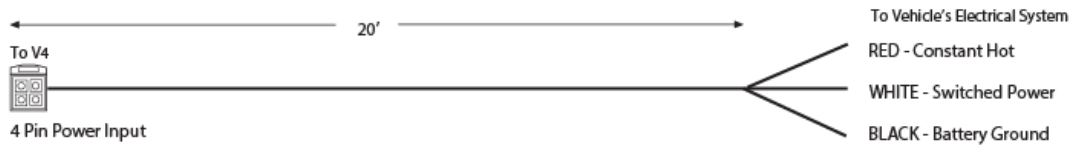

This cable requires the vehicle to physically move at least 5 MPH for at least 100 feet to properly complete new installation checkout. If this is not performed, GPS and discrete input data will not be present in Ground Traffic Control until those thresholds are met.

## Light Duty Power/Data Cable

Use this cable for light duty vehicles that are equipped with the OBDII Diagnostic Port.

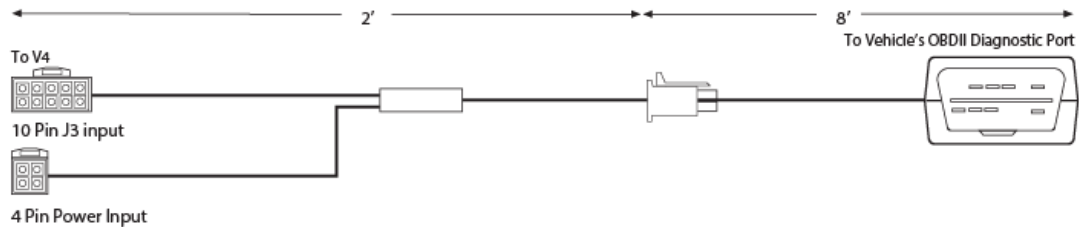

This cable has the following requirements:

- The vehicle should have a sticker or plate under the hood explicitly stating “OBDII compliant” or “OBDII Certified,” for example:



- Do not use on hybrid vehicles.
- Do not install on vehicles that already have third-party aftermarket equipment installed on the OBDII network (for example, wheel chair lift transmission lockout, boom truck transmission lockout, fuel monitoring devices, etc.)



Failure to comply with these requirements may cause interference with the safe and normal operation of the vehicle.

### To install the light duty cable:

1. Connect to the OBDII diagnostic port with the engine running. Failure to perform this step may trigger a false check engine light on the dash on first engine start after installation. This will require the fault to be manually cleared.
2. *Required.* Move the vehicle at least 5 MPH for at least 100 feet to properly complete new installation checkout. If this step is not performed the GPS and discrete IO data will not be present in Ground Traffic Control™ until those thresholds are met.



## 9 Pin Diagnostic 500K Cable

Use this cable on heavy duty vehicles with SAE J1939 data buses. The cable connects to the 9 Pin Deutsch diagnostic port. The optional 6 - 9 pin adapter (Part# 81632) is available for J1708 connections.

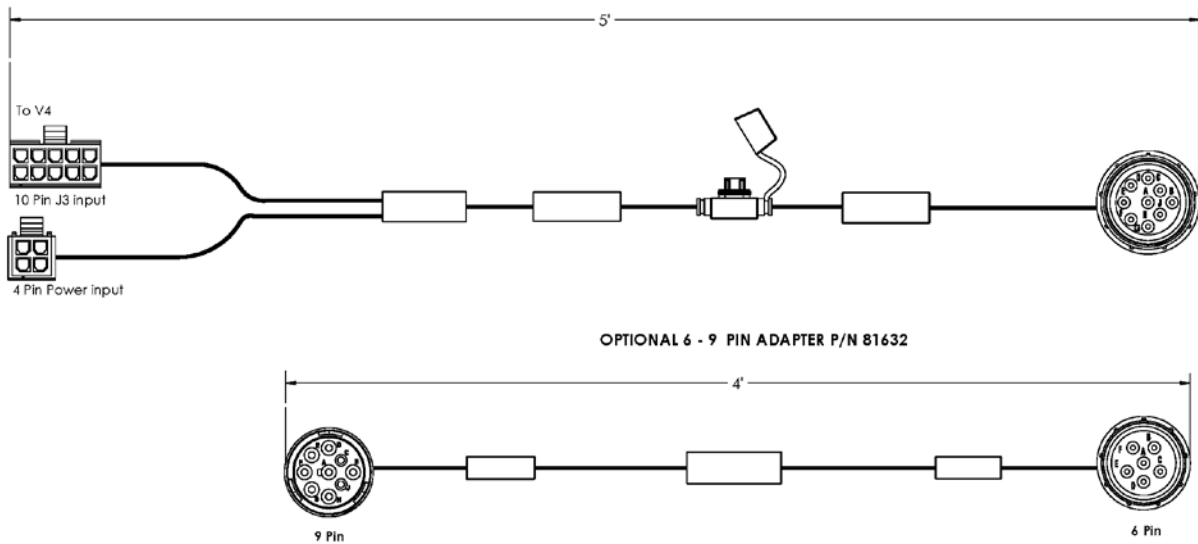

## 2-Pin Deutsch 500K Cable (Backbone)

Use this cable on heavy duty vehicles with SAE J1708/J1587 (older) or SAE J1939 (newer) data buses. The cable connects to the data network backbone.

**Note:** This cable requires specific adapters dependent on vehicle make/model/year and engine manufacturer. Contact Zonar Customer Care for additional information.

See [4 Pin Testing and Cable Management](#) and [Wiring Guidelines](#) for procedures.

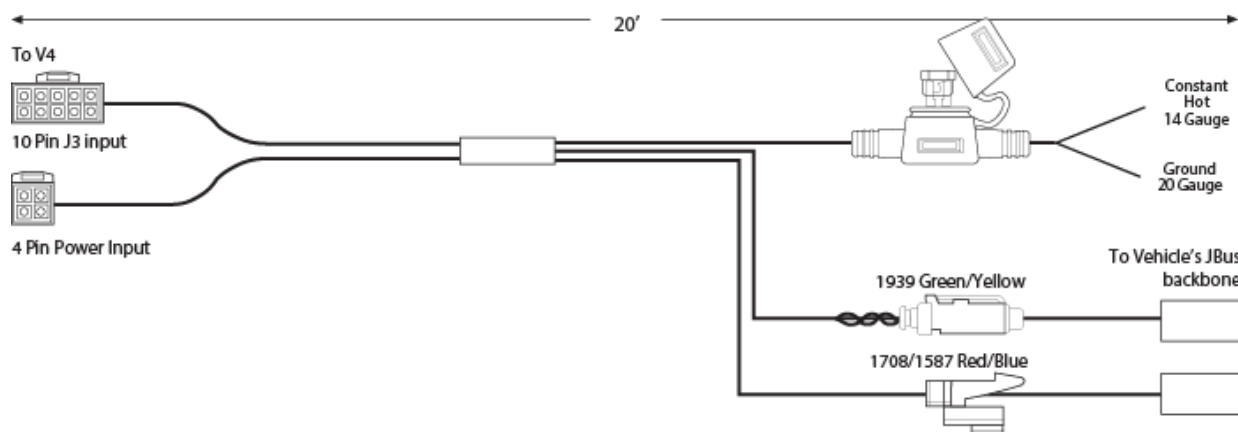

## 4 Pin, 4 Wire Power Cable

This cable is similar to the Pin, 3 Wire Cable but it adds a green chassis ground wire. This power cable is only needed for vehicles equipped with negative side battery disconnect switches (typically construction equipment).

This cable requires the vehicle to physically move at least 5 MPH for at least 100 feet to properly complete new installation checkout. If this is not performed, GPS and discrete input data will not be present in Ground Traffic Control until those thresholds are met.

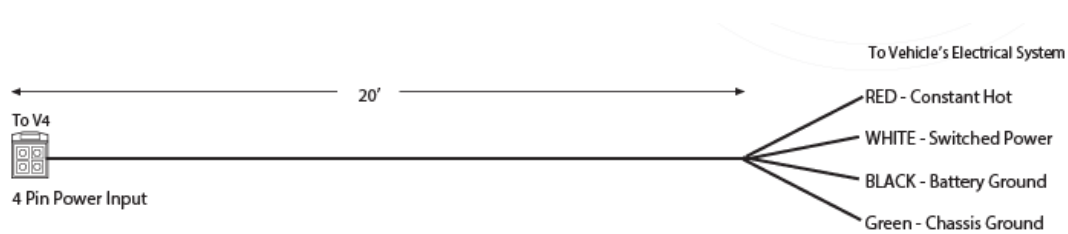

## 4 Pin Testing and Cable Management

The 4 pin power cable is used on Non-J1708/J1939 and non-OBDII installs. It is also used on J1708/J1939 installs with switched power issues (as indicated by flashing “Status” LED with engine running). See [General Guidelines](#) and the following requirements.

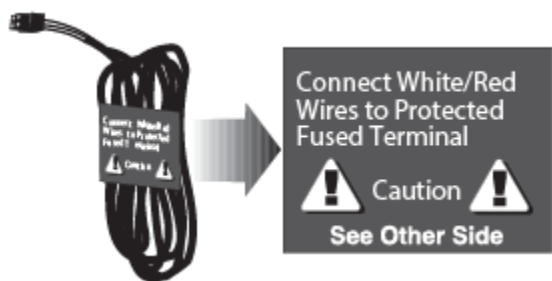

1. All power leads must be connected to the vehicles protected circuitry (for example, the fuse panel and circuit breaker panel protected circuits). Never electrically connect Zonar equipment to unprotected circuits (for example, directly to the battery).
2. All power leads (red and white) must be protected with a 3 to 5 amp fuse and inline fuse holder (included) for optimal system protection.
3. Electrical fuses should be installed as close as possible to the source of power.
4. For vehicles equipped with “noise kill” switches (late model school buses) – **Do not** wire any Zonar equipment to the “noise kill” circuitry.

### Power Bundle Wiring – 4 Pin

- Red – Constant DC (+8 VDC to +32 VDC), dependent on system type
- Black – Battery Ground must be less than 1 ohm (measure from 4 Pin connector to chassis attachment point)
- Green - Chassis ground (Cable P/N 10030 only).
- White - Switched Power
  - Engine running (+8 VDC to +32 VDC)
  - Engine not running (0 VDC)
  - Engine not running (key position ACC or Accessory Mode) (0 VDC)



The white wire must be connected to a power source that is active only when the engine is running *or the system will not track idle time properly.*

**Note:** Please contact the vehicle manufacturer for any specific electrical questions.



If power cabling is not connected and powered as described in the [Power Bundle Wiring](#) section, one or more of the following conditions may occur. Contact Zonar Customer Care for additional information.

- Cold Start flags (an indicator that a unit lost and regained constant power)
- Inaccurate idle and stop times
- Inaccurate hour meter data
- Inaccurate mileage data
- Missing path data
- Straight line data segments

## Using a Digital Multimeter (DMM) Probe for Testing 4 Pin Cable

A digital multimeter (DMM) is a test tool that is used to measure two or more electrical values such as voltage (volts), current (amps), and resistance (ohms). It is a standard diagnostic tool for technicians in the electrical industry.

Improper use of the DMM probe may damage the pins causing an intermittent connection. Be sure the probe only makes contact with the outside edge of the female connector. If the probe is inserted into the connector it may distort the pin and ruin the connection.

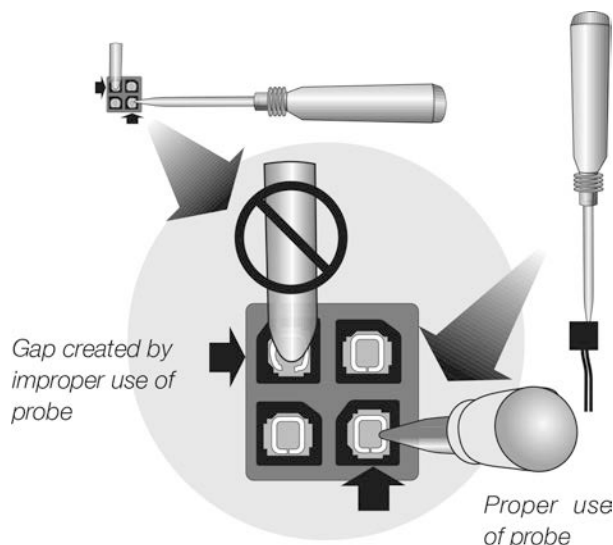

## Wiring Guidelines

The wiring guidelines in this section are for unterminated power and ground leads—4 Pin and Backbone. The authorized method for power termination on the Zonar V4 system is the use of Add-a-Circuit fuse taps. Whenever possible, use fuse taps for power termination. If, due to the particular make/model/year of the vehicle being installed, fuse taps cannot be used then the poke and weave method of termination can be utilized.

**Note:** All wiring terminations MUST be fused regardless of Add-a-Fuse tap or poke and weave method of installation.

### Fuse Taps Installation

1. Ensure that the fuse tap seats fully in the correct location.
2. If another fuse, a relay, or any other object in the fuse panel prevents the fuse tap from seating fully, relocate the fuse tap. *It is not permissible for the fuse tap to rub or make contact with other items in the fuse panel.*
3. In addition, you must be able to re-secure the fuse panel cover or door once the fuse tap is installed.
4. Whenever possible, use an empty location in the fuse panel that does not have an existing fuse. If it is not possible to use an empty location, ensure that the existing fuse is placed in the correct location on the fuse tap. See below for an example.



### Poke and Weave Installation

Whenever it is not possible to use Add-a-Circuit fuse taps then the poke and weave method must be used.

1. Locate the proper wire where the poke and weave method is to be installed. Strip 3/4" to 1" of insulation from the wire in the vehicle to be installed. Spread the wire strands apart as shown below.



2. Strip 1" to 1 1/2" of insulation from the wire in the fused link to be installed.

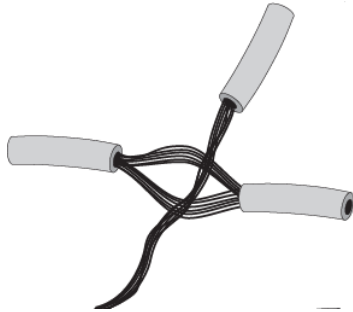

3. Insert the wire from the fused link into the spread wire in the vehicle. Wrap around the wire several times.

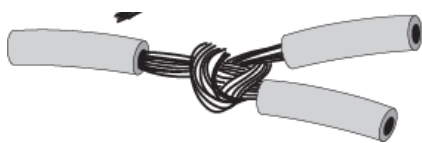

4. Cover the exposed wires with several wraps of electrical tape or mastic. Place one wire tie over the electric tape over the exact location where the wires are 'wrapped' together. Place another wire tie 1" to 2" from the first wire tie, to secure the two wires together and as stress relief.

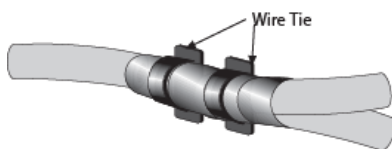

**CAUTION:** Zonar has approved two types of fuse taps. Use of other brands is not authorized. Do not install these fuse kits in fuse panel locations greater than 10 amps.

- LitteFuse brand: Add-a-Circuit
- Bussman brand: Add-a-Fuse

## External GPS Antenna (Optional)

External antennas are generally only necessary if the V4 GPS unit is enclosed in a radio signal interfering area (e.g. metallic box, under seats, on dashboards with flat windshields, and in cabs or cockpits constructed primarily from metallic material).



The suggested installation point is the centerline of the vehicle roof, with minimal cable run to prevent wind and car wash damage. Ensure that there is a clear antenna view of the open sky, and maintain a minimum of 6 inches from any rooftop edge or ledge. See below.

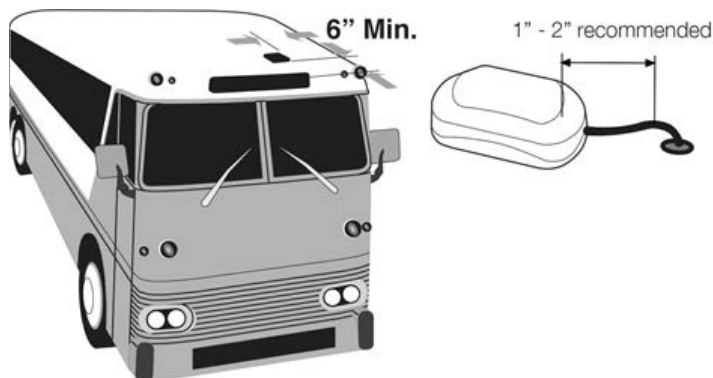

Drill, deburr, grommet, weather seal, and cable thru hole as required. Drill hole size - 1/2" (.500"); grommet size - 3/8" (.375").

### Optional GPS Antenna Adhesive Tag (for non-magnetic mounting surfaces)

Whenever possible, avoid installing adhesive in cold, wet, or damp conditions. Ideal application range is: 70 °F to 100 °F (21 °C to 38 °C).

1. Clean and dry the surface prior to placement to obtain optimum adhesion. The best surface cleaning solvent is an isopropyl alcohol/water mixture (rubbing alcohol).
2. Remove the backing from the peel and stick to the surface.

3. Press and hold mounting position for 10 seconds to assure good adhesion.

## GPS System Check

At a minimum, the installer must perform a system check to verify proper installation. If at all possible a full and complete checkout using Zonar's Ground Traffic Control® website should be performed. Not all installers will have access to this area; check with a Zonar Customer Service representative if in doubt. This procedure covers the minimum requirements for a system installer.

### Check the LEDs

Turn the key on, and with the engine running check the LEDs on the GPS unit within 2 minutes. They should display the following sequence after everything is connected.

LED	Condition
CELLULAR	Solid <b>green</b> . If blinking, ensure unit is in an area with cellular coverage.
GPS	Solid <b>green</b> or <b>orange</b> . If blinking, the GPS is acquiring satellites (antenna must have a clear view to sky). Do not proceed further until GPS LED is solid.
STATUS	Solid <b>green</b> . If blinking, check the cables at the GPS unit and the vehicle connector. Also check the integrated 4 Pin power pigtail at the GPS unit. If the cables and the 4 Pin power pigtail are good, use a standalone 4 Pin power cable. <b>Note:</b> STATUS will blink fast <b>red</b> when power is removed and the device is operating on internal backup power. <b>Note:</b> STATUS will blink <b>blue</b> upon startup if Bluetooth is enabled while the device is in pairing mode.
DATALINK1	<ul style="list-style-type: none"> <li>• Single <b>green</b> blink per second if J1708/J1587 data is present.</li> <li>• Single <b>green</b> blink per second if good communication between the Light Duty cable and the GPS device.</li> <li>• Single <b>red</b> blink per second if no ECM connection or if ECM connection not working properly.</li> </ul>
DATALINK2	<ul style="list-style-type: none"> <li>• Single <b>green</b> blink per second if J1939 data is present.</li> <li>• Single <b>green</b> blink per second if good communication between the Light Duty cable and the GPS device.</li> <li>• Single <b>red</b> blink per second if no ECM connection or if ECM connection not working properly.</li> </ul>



## Turn Key Off

Turn the key off, and check the **STATUS** LED on the GPS unit. It should be blinking **green**—solid may indicate a problem, check the white lead. Contact Zonar Customer Care if in doubt.  
Note: Disregard the other LEDs for this check.

## Turn to Accessory Position

Turn the key to the accessory position with the engine off. STATUS LED must not be solid.

**Note:** A proper and complete system/LED functional check requires the engine to be running.

## System Checklist

Customer:	Yard:	Date:	Asset #:
Installer:	Location:	GPS ID:	
Vehicle Odometer Value:		Vehicle I.D. (e.g., Vin, Plate#, Make, Model, Year)	

System Check	Yes/No	Notes
<b>General Layout</b>		
General condition - components level, even, straight, etc?		
System layout conforms to your established standard?		
<b>Drilling and Cutting</b>		
All drill holes grommeted (or otherwise protected), deburred, sealed (weather penetrations only)		
All chips captured?		
<b>Cable Management</b>		
All cables properly ran (no tight radius, no interference, strain relieved, supported, service looped)?		
<b>Electrical</b>		
System hookup complies to your established standard?		
Red lead voltage verified? (12V constant)		
White lead voltage verified? Engine on-12V, engine off-OV, key-accessory position with engine off-OV		
Black lead continuity verified? (Grounded to vehicle chassis)		
Verify crimp integrity?		
Verify fuse holder and fuse installation?		
<b>GPS/ECM System checkout</b>		
GPS/ECM LED light check? (engine on/engine off) (key in accessory position)		
Verify GPS position uploaded to GTC website?*		
<b>Post Job</b>		
Key accounted for?		
Vehicle secure?		
Lights, electrical off?		
All debris, refuse, chips removed?		
<p>*For 4 Pin or OBDII installed vehicles: Requires vehicle to physically move at least 5 MPH for at least 100 feet to properly complete new install checkout. If this is not performed GPS and discrete input data will not be present in GTC until those thresholds are met</p>		<p>_____ INSTALLER SIGNATURE</p> <p>_____ Date</p>

## System Specifications

### Electrical

DC Input Range:	8 VDC to 32 VDC
Operating Current:	100 mA @12V (typical without peripherals) 500 mA @12V (maximum without peripherals)
Key-Off Current:	<1mA

### Environmental

Operating Temp:	-40C to 85C
Storage Temp:	-40C to 85C
Humidity:	95% R.H., non-condensing
Shock/Vibration:	SAE J1455, MIL-STD-202G

### GNSS Receiver

GPS/Glonass	WAAS, EGNOS, MSAS, GAGAN, QZSS
Very High Sensitivity receiver	Rapid satellite acquisition
Anti-Jamming, Anti-Spoofing	

### Cellular

LTE (Cat4) bands 2/4/5/7/17	UMTS (3G) 850/900/1700/1900/2100 MHz
GSM (2G) 850/900/1800/1900 MHz	

### External GPS Antenna (*optional*)

Zonar Part 81304 (17')

## V4 and Mount Dimensions

V4™

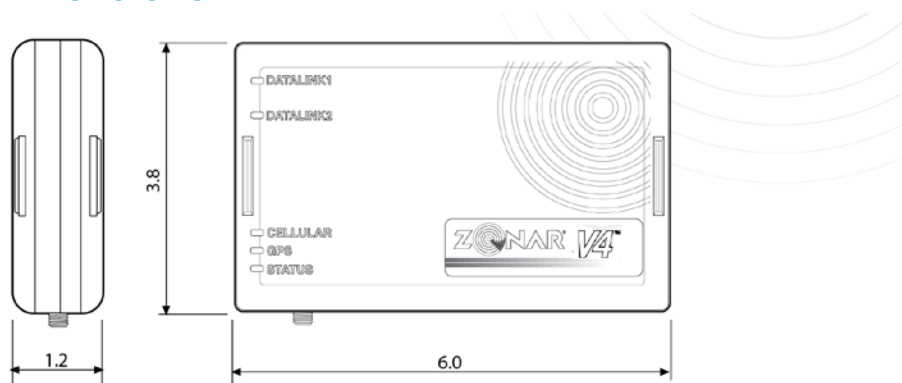

V4™ MOUNT

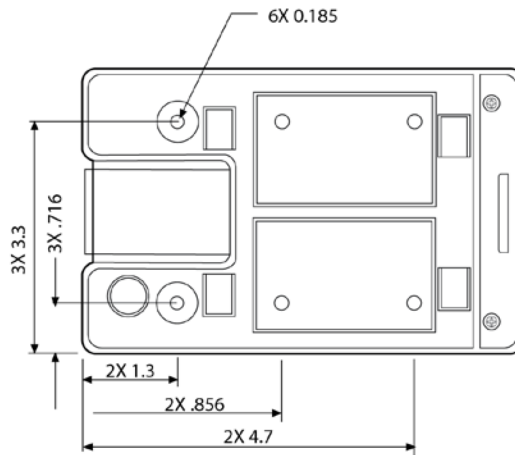
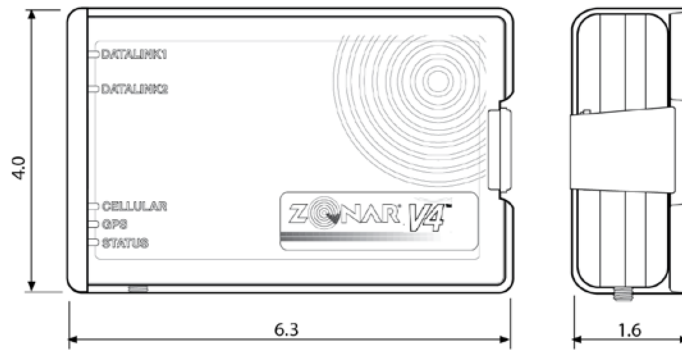

DIMENSIONS IN INCHES

Please note that these are reference dimensions only.

## Typical Installation

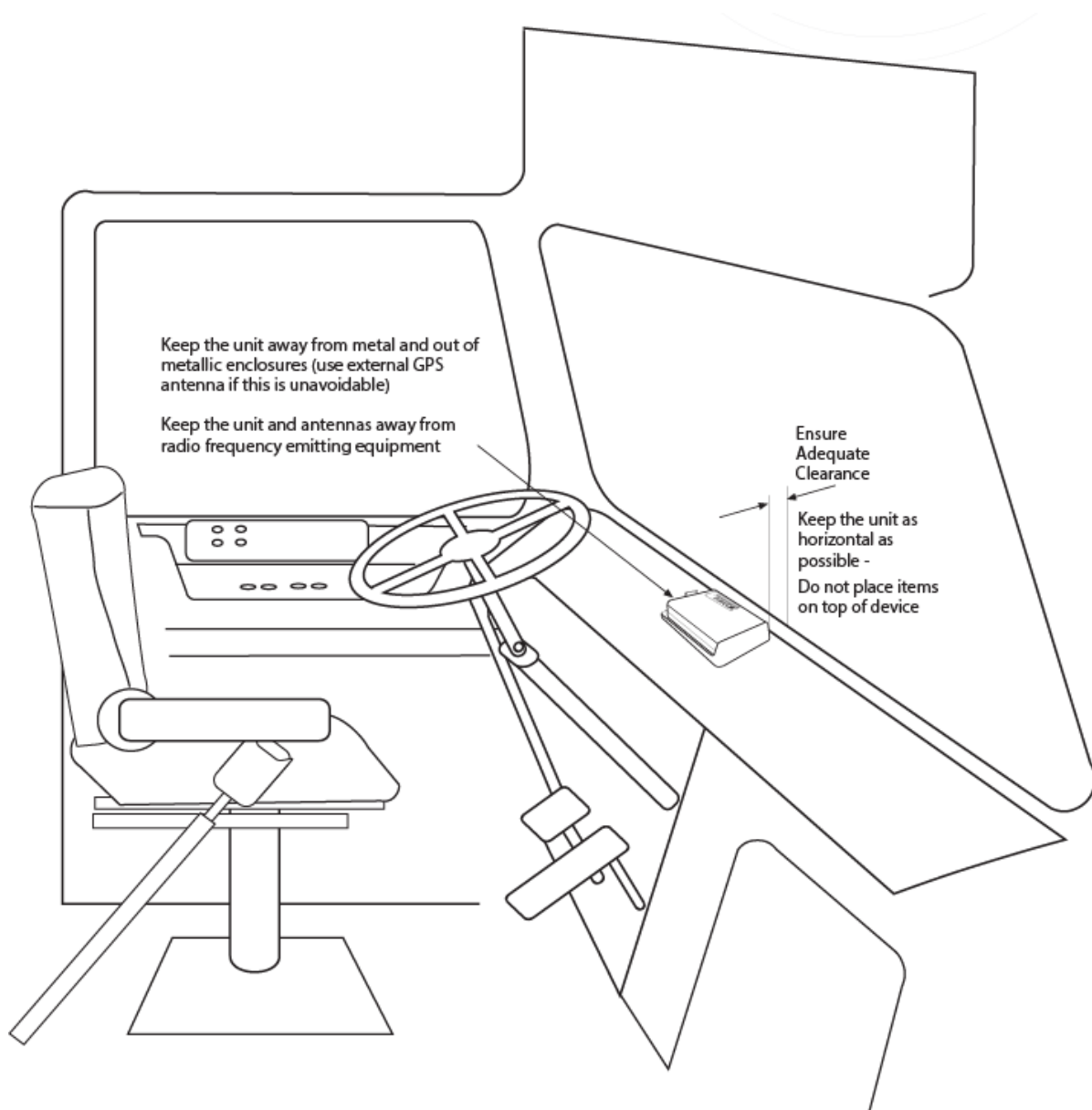

## Installation Example

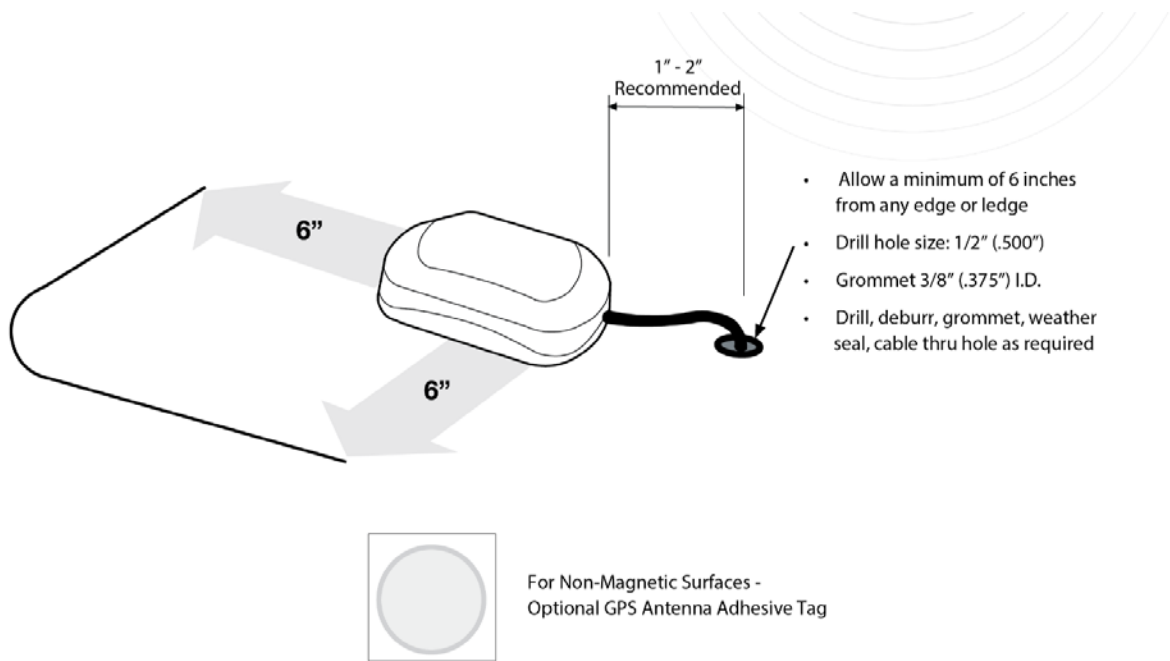

### CORRECT

- Bend radius adequate
- Hole has grommet

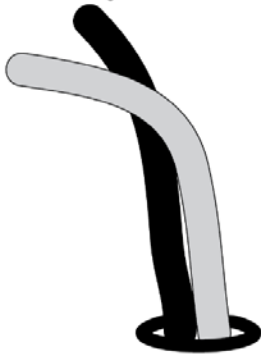

### INCORRECT

- Bend radius too tight
- Hole has sharp edges
- Hole has no grommet

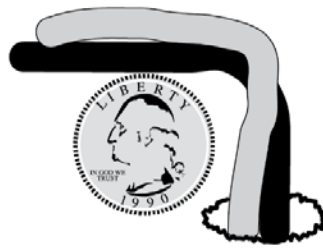

## System Installation

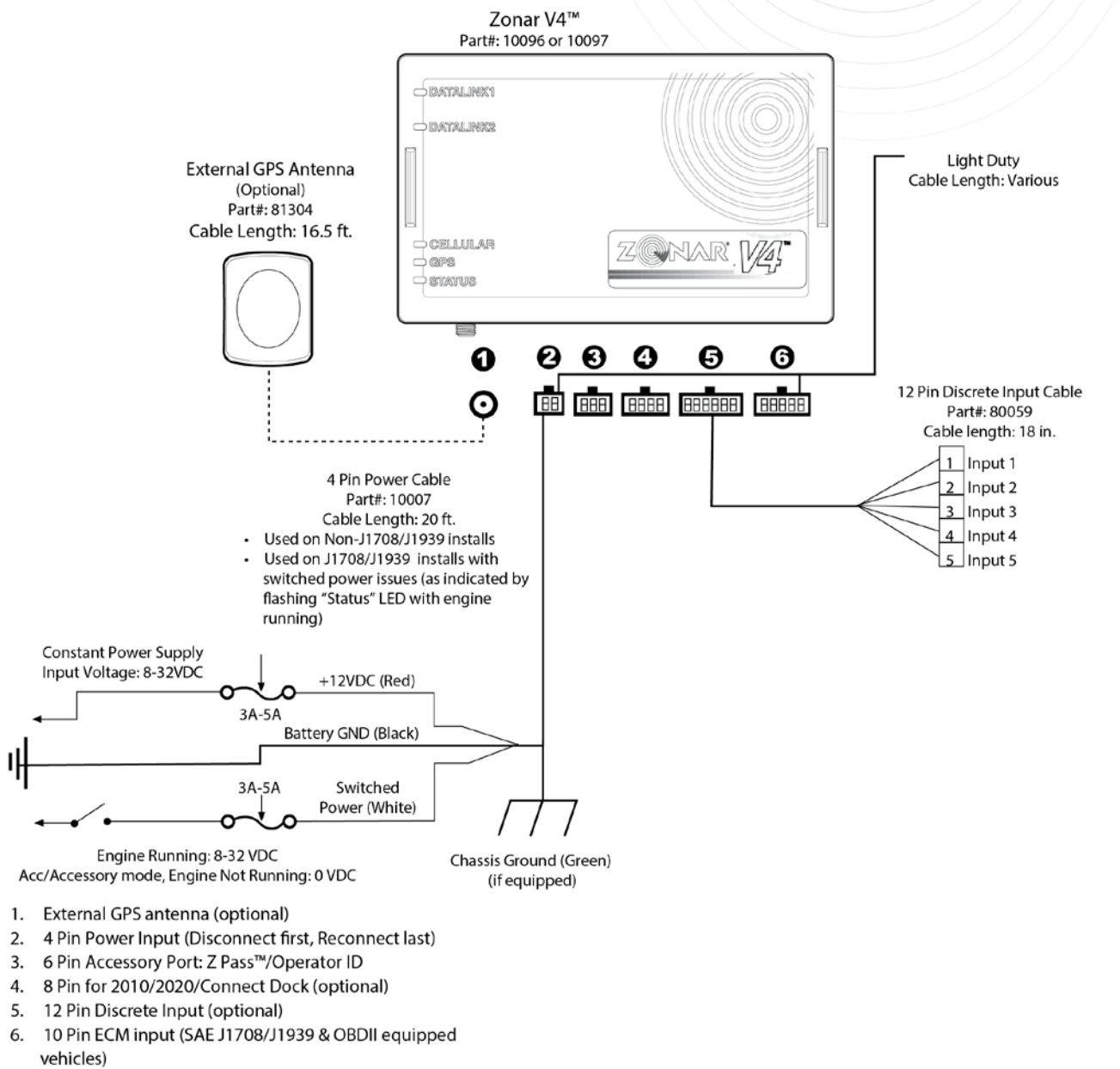

## Zonar Discrete Input System

### Zonar Discrete Input System

The purpose of this schematic is to tap onto an existing switched control circuit



#### WARNING:

Observe all general and specific warnings in regards to electrical installations at the beginning of this guide.

When in doubt consult the specific vehicles manufacturer for electrical installation instructions.

Do not connect to multiplex wiring.

#### Zonar Discrete Input Wiring Details

- 5 Inputs (depending on application, all inputs may not be used)
- 20 AWG wire gauge

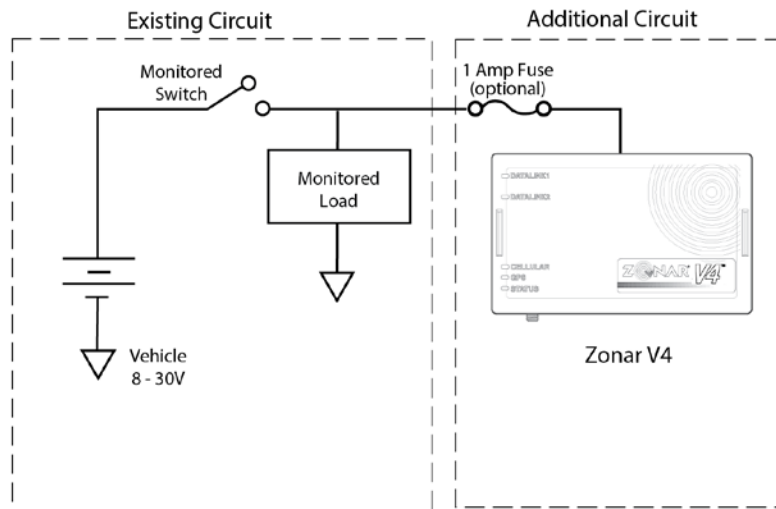

#### Optional Fuse (Not Supplied)

Note: The monitored vehicle circuit should always be electrically protected. In the event this circuit is not properly electrically protected, install 1 Amp fuse as indicated to the left. Electrical fuses should be installed as close as possible to the source of power.

#### Notes:

- 1) Suggested uses -  
 Door: Open/Closed  
 Plow: Up/Down  
 PTO: On/Off  
 Sweeper: On/Off  
 Light: On/Off  
 Arm: In/Out
- 2) Do not connect to pulsing, flashing, or high cycle circuits (e.g., Flashers, Foot Brake, Turn Signals). Doing so may result in higher data rate fees.
- 3) Do not connect to sub-3 second cycling circuits.
- 4) Activity States  
 Low = battery ground  
 High = battery voltage
- 5) Route all cables and wiring away from high voltage and RFI circuits. These may induce false signals.
- 6) Contact Zonar if other I/O configurations are required, such as swapping load and switch or using non-standard voltage thresholds.

Note: Monitored Switch could be a physical switch or the load side of a relay. A relay may be required if the desired control signal is not of an appropriate voltage level. Monitored Load could be a lamp or the control side of a relay. Load is not required (for example: driver pushbutton for input trigger only or door ajar sensor).





## Warranty

### Limited Warranty

LIMITED WARRANTY: Zonar warrants that the Hardware provided under this agreement is free from all material defects in workmanship under normal use and service. Zonar's warranty period for its Hardware is as follows:

- V4 Product Line - 3 Years
- All Other Hardware - 1 Year

The above warranty periods run from the date of shipment. Provided that the Hardware is used and handled as intended, Zonar will replace any failed or functionally impaired Hardware with equivalent Hardware in terms of performance and functionality.

This warranty does not apply to any Hardware that has been misused, altered, willfully abused or that has been damaged due to improper installation by the customer. Hardware installations must follow Zonar's equipment specific installation guidelines. If product returned is determined to be damaged due to any of the aforementioned circumstances, the Customer will be charged the price of a refurbished unit plus shipping and handling.

CUSTOMER'S SOLE AND EXCLUSIVE REMEDY AND ZONAR'S ENTIRE OBLIGATION UNDER THESE LIMITED WARRANTIES for defective equipment is the repair and replacement of the equipment free of charge by Zonar. Zonar shall not be liable to Customer or any third party for any general, special, punitive, incidental, indirect or consequential damages, or any lost profits or business, arising out of Zonar's Subscription Agreement.

## Notices

It is the Owner's sole responsibility to install and use the Zonar products in a manner that will not cause accidents, personal injury or property damage. For the purposes of this notice, "Owner", "you" and "your" means the party (including any person authorized by that party to use and/or install the Product) that has either: (a) purchased the Product; or (b) leased the Product from Zonar Systems, Inc or its related companies. The Owner of this product is solely responsible for observing safe driving practices. The choice, location, and installation of all components of the Product is critical. If installation is not correct, the Product may not perform at its designed potential or specifications. If in doubt, consult your vehicle's manufacturer.



### **Warning: (Part 15.21)**

Changes or modifications not expressly approved by Zonar Systems could void the user's authority to operate the equipment.



### **Caution: RF Exposure (OET Bulletin 65)**

To comply with FCC RF exposure requirements for mobile transmitting devices, the antenna(s) used for this transmitter must be installed to provide a separation distance of at least 25 cm (10 inches) from all persons and must not be co-located or operating in conjunction with any other antenna or transmitter. Users and installers must be provided with antenna installation instructions and transmitter operating conditions for satisfying RF exposure compliance.

Use only supplied and approved antennas. Use of unauthorized antennas or modifications could impair signal quality, void your warranty and/or result in violation of FCC regulations.



### **FCC Compliance Statement (Part 15.19), IC Compliance Statement (RSS-210)**

This device complies with Part 15 of the FCC Rules and with RSS-210 of Industry Canada (IC). Operation is subject to the following two conditions:

1. This device may not cause harmful interference, and

2. This device must accept any interference received, including interference that may cause undesired operation.

Cet appareil est conforme aux normes CNR exemptes de licence d'Industrie Canada. Le fonctionnement est soumis aux deux conditions suivantes:

1. cet appareil ne doit pas provoquer d'interférences et
2. cet appareil doit accepter toute interférence, y compris celles susceptibles de provoquer un fonctionnement non souhaité de l'appareil.

## Legal Information

This manual is subject covered by copyright, and all rights are reserved, noting that current Zonar customers may reproduce this manual for their internal business use only, and only during the term of their contract with Zonar. With respect to references in this manual to US laws and regulations, such information is available in the public domain, and Zonar's assertion of copyright is limited to the compilation and arrangement of such information along with other materials in this publication. Zonar uses commercially reasonable efforts to provide accurate information with respect to such laws and regulations, but the user of this publication is advised that such laws and regulations are subject to change and evolving interpretations. As such, Zonar does not warrant that the information herein is error free. Zonar specifically disclaims any liability for any errors, omissions, ambiguity or misprinting contained here, and Zonar expressly reserves the right to update and modify this manual as it deems appropriate. This manual is not intended to provide legal advice, but rather is intended to provide commercially reasonable information about Zonar's products and the regulations relating to such products, as the regulations and products exist at the time of this publication. Users are advised to seek their own legal counsel if legal advice or expert assistance is required.

© 2018 Zonar Systems • 2010; EVIR; FieldView; Ground Traffic Control; GTC; V3; V4; Z PASS; Z PASS+; ZFuel; ZLOGS; Zonar; Zonar Coach; Zonar Connect; Zonar Count; Zonar Docs; Zonar Forms; Zonar Logs; Zonar Systems; Zonar Verify; Zone Tags; and ZTRAK are trademarks of Zonar Systems. RAM and Wi-Fi are third party trademarks of National Products Inc. and Wi-Fi Alliance respectively. All Rights Reserved.

Zonar products and services are protected by one or more of the following US patents: 6,502,030; 6,671,646; 6,804,626; 7,048,185; 7,117,121; 7,362,229; 7,557,696; 7,564,375; 7,680,595; 7,769,499; 7,808,369; 7,944,345; 8,106,757; 8,400,296; 8,736,419; 8,810,385; 8,914,184; 8,918,229; 8,972,097; 8,972,179; 9,092,968; 9,170,913; 9,229,906; 9,230,437; 9,280,435; 9,292,978; 9,358,986; 9,384,111; 9,412,282; 9,424,696; 9,489,280; 9,527,515; 9,563,869; 9,607,464; 9,747,254; 9,747,794; 9,787,950; 9,805,538; 9,815,681; 9,828,233; 9,856,129; 9,858,462; and 9,881,432. Zonar products and services are also protected under Canadian patents 2,458,050 and 2,478,303; as well as European patent EP 1573427.