

***Test Report No.8412305148***

***For Medic4All (Israel) Ltd.***

***Equipment Under Test:***

***WristClinic***

***Model: AIO-67 (915 MHz)***

***From The Standards Institution  
Of Israel  
Industry Division  
Telematics Laboratory  
EMC Section***



***Certificate No. 1487-01***

**Test Report No.:** 8412305148

**Page 1 of 24 Pages**

**Title:** Test on WristClinic

**Model:** AIO-67 (915 MHz)

<b>Order placed by:</b>	Medic4All (Israel) Ltd.
<b>Address:</b>	10 Hamefalsim Str., P.O. Box 4222, Petach-Tikva 49000, Israel
<b>Sample for test selected by:</b>	The customer
<b>The date of test:</b>	14, 20/04 10, 15/05/2004

**Description of Equipment Under Test (EUT):**

**WristClinic**  
**Model:** AIO-67 (915 MHz)  
**Manufactured by:** Medic4All (Israel) Ltd.

**Reference Documents:**

- ❖ CFR 47 FCC: Rules and Regulations; Part 15. "Radio frequency devices";  
Subpart B. "Unintentional Radiators".  
 Section 15.109. "Radiated emission limits".  
Subpart C: "Intentional radiators" (2002),  
 Section 15.205. "Restricted bands of operations",  
 Section 15.209. "Radiated emission limits, general requirements".  
 "Radiated Emission Limits, Additional Provisions";  
 Section 15.249. "Operation within the bands 902 - 928 MHz,  
 2400 - 2483.5 MHz, 5725 - 5875 MHz, and 24.0 - 24.25 GHz".

**Test Results:** The EUT meets the following requirements of CFR 47 FCC Part 15:  
 Subpart B Section 15.109. Radiated emission Class B.  
 Subpart C Section 15.209. Radiated Emission,  
 Section 15.429 (a),  
 Section 15.205.

This Test Report contains 24 pages  
and may be used only in full.

This Test Report applies only to the specimen tested and may not  
be applied to other specimens of the same product.

## **Table of Contents**

<b>1. EUT Description and operation</b>	<b>3</b>
1.1. General description:	3
1.2. EUT's sub-assemblies list:	9
1.3. EUT connector list:	9
1.4. Potential emission sources:	10
1.5. EUT setup and operation:	10
<b>2. Measurements, examinations and derived results</b>	<b>10</b>
2.1. Location of the Test Site:	10
2.2. Test condition:	10
2.3. Initial visual check and functional test:	10
2.4. Radiated emission test:	11
2.5. General:	11
2.6. Test of field strength of emission from intentional radiators	13
<b>3. Test summary</b>	<b>18</b>
<b>4. Appendix 1. Test equipment used</b>	<b>19</b>
<b>5. Appendix 2: Antenna Factor and Cable Loss</b>	<b>20</b>
<b>6. Appendix 3. Test configuration illustrations</b>	<b>24</b>

## 1. EUT Description and operation

### 1.1. General description:

\* Note: All information in below clause was supplied by the customer.

**Description of Equipment Under Test (EUT):** WristClinic

**Model:** AIO-67 (915 MHz)

**Manufactured by:** Medic4All (Israel) Ltd.

The AIO-67 is a multi-function medical monitoring device which performs the following measurements: blood pressure, ECG, heart rate, breathing rate, heart rhythm regularity, body temperature and oxygen saturation (internal or external sensor).

The AIO-67 communicates with the MedicGate (VMG02) and with the MiniGate (VMG03) via wireless protocol and also can communicate with a other peripheral devices via RS-232 interface.

Tested model has carrier frequency 915 MHz.

The EUT is Transceiver based on chipset Chipcon CC1020.

The transceiver uses one channel.

Integrated antenna – printed circuit board (PCB).

The EUT was tested together with following devices:

1. with AIO-67 thermometer
2. with External SPO2 monitor.

Output transmission power: -1 dBm (EIRP)

Bandwidth: 50 kHz

Modulation type: FSK.

The EUT's dimensions: : 9 cm x 8 cm x 8 cm.

The EUT's powered from two 1.5V AA batteries.

The current consumption of the AIO-67 is up to 240 mA.

The EUT's block diagram and Tx block diagram are shown in Figures 1 and 2, respectively/.

The AIO-67 external and internal views are presented in Photos ##1-2.

The SPO2 external vies are presented in Photos ##3-4.

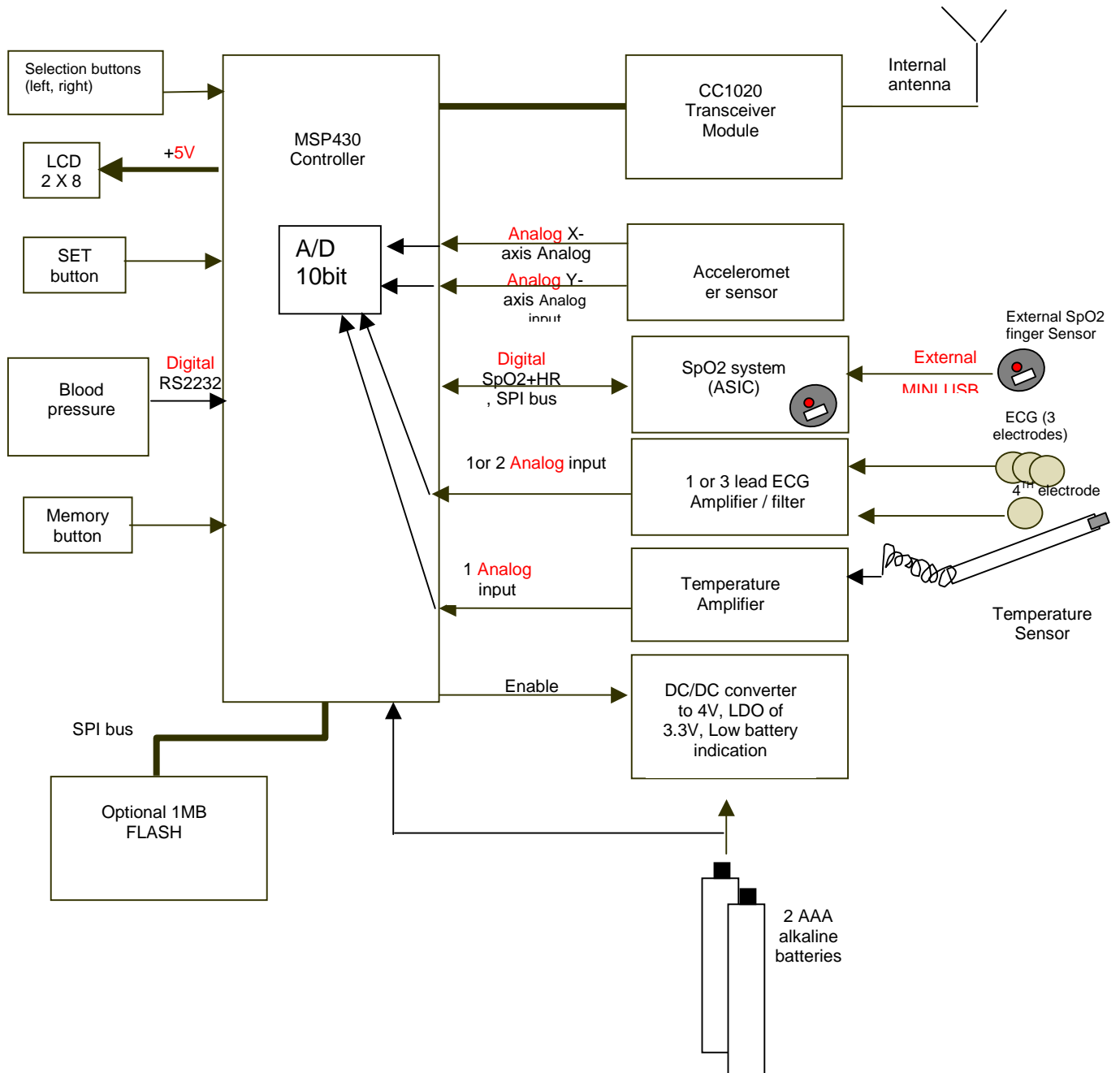

**Figure 1. EUT's block diagram**

### Circuit Description

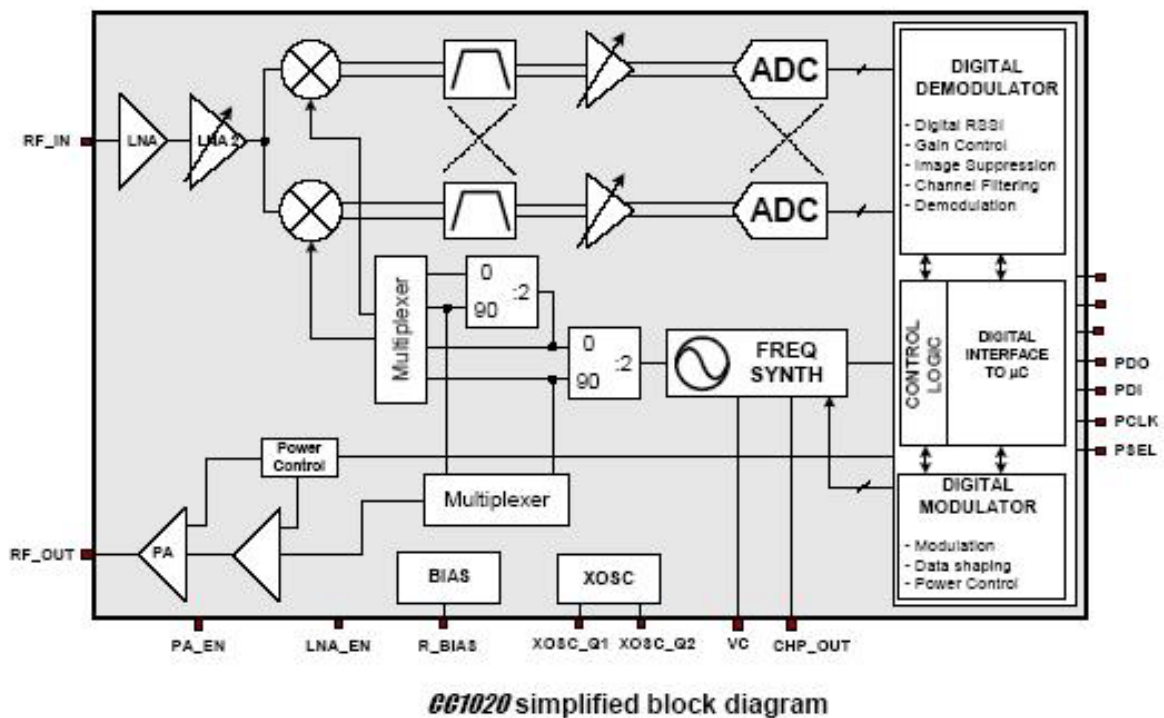

Figure 2. Tx-Rx block diagram



**Photo 1. AIO-67 with thermometer and SPO2 connected**

**Test Report No.:** 8412305148

**Page 7 of 24 Pages**

**Title:** Test on WristClinic

**Model:** AIO-67 (915 MHz)



**Photo 2. EUT's internal views**



**Test Report No.:** 8412305148

**Page 8 of 24 Pages**

**Title:** Test on WristClinic

**Model:** AIO-67 (915 MHz)



**Photo 3. SPO3. Front/ side overall view**



**Photo 4. SPO. Rear view**

\* Information in clauses below is provided by the manufacturer.

**1.2. EUT's sub-assemblies list:**

EUT's sub-assemblies list is detailed in table below.

**Table 1. Sub-assemblies list**

Function	Mfr / Serial No./ Model
Main board	AD4439
Blood pressure board	HEM-637 mfr Omron
AIO-67 thermometer	mfr Medic4All
External SPO2 monitor	AIO-67 / SPO2 mfr Medic4All

**1.3. EUT connector list:**

A list of the EUT's connectors is detailed in Table 2.

**Table 2. Connector list**

No.	Connector's name	Connector's type	Type of Cable	Length (m)	No. of identical connectors
1	Temperature	3.5mm jack	Three wire shielded	1.0	1
2	AUX	2.5mm jack	Two wire shielded	0.50	1
3	Ext SPO2	Mini USB type-B	Four wire shielded	0.30	1

\* Information in clauses below is provided by the manufacturer.

#### **1.4. Potential emission sources:**

The potential emission sources are detailed in Table 3.

**Table 3. Potential emission sources**

Frequency	Location
14.7456 MHz crystal	AD4439 board
32.736 kHz crystal	AD4439 board
915 MHz RF signal	AIO-67 base unit

#### **1.5. EUT setup and operation:**

The AIO-67 thermometer and External SPO2 monitor were connected to the AIO-67. Respective tests were performed in Transmission (Tx) and Receiving (Rx) modes.

## **2. Measurements, examinations and derived results**

#### **2.1. Location of the Test Site:**

Preliminary radiated test and immunity tests were conducted at the EMC laboratory of the Standards Institution of Israel in Tel-Aviv.

All other tests were conducted in an Open Area Test Site located at Kibbutz Native Halamed Hai in Emek HaEla, Israel.

#### **2.2. Test condition:**

Temperature: 22 °C. Humidity: 56 %. Atmospheric pressure: 1010 mbar.

#### **2.3. Initial visual check and functional test:**

Initial visual check and brief built- in- test of the EUT was performed before testing.

- No external damages were found.
- The test on the EUT passed successfully.

## **2.4. Radiated emission test:**

### **2.5. General:**

Per FCC Part 15 Subpart B Section 15.109 / Subpart C Section 15.209.

- \* Initial scans were made using a peak detector but still using the appropriate CISPR 16 (Quasi-Peak) detector IF bandwidth.
- \* A tolerance limit was set 10 dB below the specification limit. Levels above the tolerance limit were retested using the Quasi-Peak detector.
- \* If the result with a Quasi-Peak detector exceeds the specification limit, it is marked with "Fails" in the margin, if it is within the measurement uncertainty, it is marked with a "\*".

#### **2.5.1. Preliminary radiated emission tests:**

Preliminary radiated measurements were performed in a semi-anechoic chamber at a distance of 3 meters. The EUT was setup in its typical configuration and operated in its various modes. For each mode of operation the frequency spectrum was monitored. EUT configuration, cable configuration and mode of operation, which produced the maximum level of emission, were documented. A list of frequencies to be tested was prepared.

#### **2.5.2. Final measurements:**

The final radiated measurements were performed at the Open Area Test Site.

The EUT was operated as described in clause 1.5.

The EUT was installed on a turn- table. Photo of test setup is presented in Appendix 3.

All measurements at the Open Area Test Site were performed at a 10 m measurement distance.

The Biconilog 30 MHz-2 GHz antenna was used.

The EUT's configuration and mode of operation, which produced the maximum level of emissions, were selected.

The measurements were performed at each frequency found previously and at frequencies at which the signal was 10 dB below the limit or less.

All measurements at the Open Area Test Site were performed at a 10 m measurement distance from the EUT.

The levels were maximized by initially rotating turntable through 360°, varying the antenna height between 1 m and 4 m, rerouting EUT cables and changing antenna-to-EUT polarization from vertical to horizontal.

Unless stated otherwise, the measuring equipment settings were:

**Initial scan:**

Detector type	Peak
Mode	Max hold
Bandwidth	120 kHz
Step size	Continuous sweep
Sweep time	>1 seconds/MHz

**Measurements:**

Detector type	Quasi-peak (CISPR)
Bandwidth	120 kHz
Measurement time	20 seconds/MHz
Observation	>15 seconds

**2.5.3. Radiated emission test results:**

All received emissions from the EUT were found at least 20 dB below FCC Part 15 Subpart B Section 15.109 Class B / Subpart C Section 15.209 specified limits.

Preliminary test results are presented in Plot # 1 below

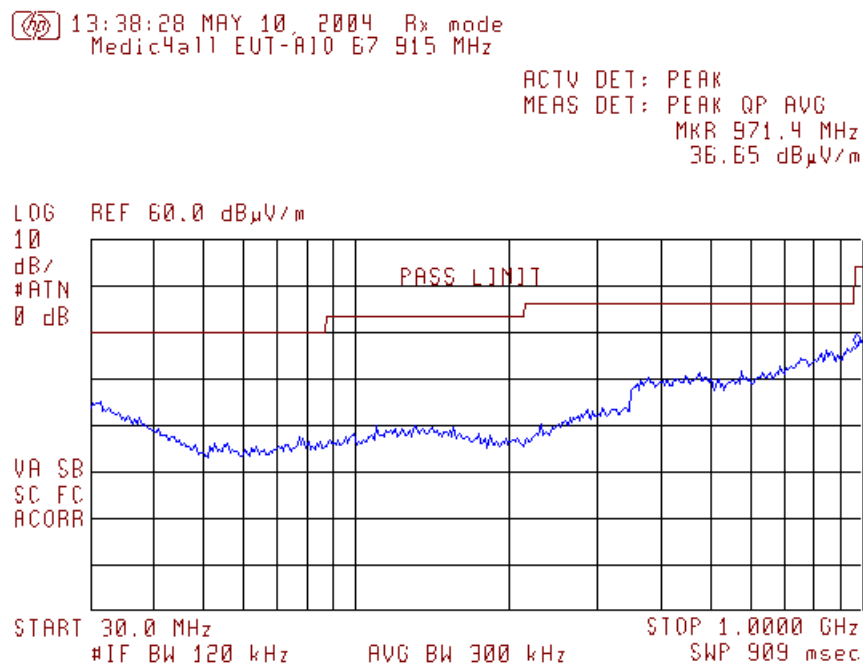

**Plot # 1. Rx mode. Scan of preliminary radiated test**

## 2.6. Test of field strength of emission from intentional radiators

### 2.6.1. General:

Per FCC Part 15 Subpart C Clauses 15.249 (a) and 15.205.

### 2.6.2. Requirements:

The EUT's operation frequency is within the bands 902 – 928 MHz.

The field strength of emissions from intentional radiators operated within these frequency bands shall comply with the following:

Fundamental Frequency	Peak Field Strength of Fundamental (millivolts/ meter)	Calculated Peak Field Strength of Fundamental dB $\mu$ V/m	AVG Field Strength of Harmonics (microvolts/ meter)	Calculated AVG Field Strength of Harmonics dB $\mu$ V/m
902 – 928 MHz	50	94	500	54

Note: Peak field strength of Harmonics not exceed the maximum permitted AVG specified limit above by more than 20 dB.

### 2.6.3. Test procedure:

The test was conducted according to clause 15.249 (a).

The measurements were conducted at the normal conditions.

The Fundamental frequency was recorded (see Plot # 2).

The measurements (spurious emission) were performed in Tx mode in the frequency range from 30 MHz to 6500 MHz (with detector QP – below 1000 MHz and AVG detector – above 1000 MHz).

Test of range of modulation bandwidth (20 dB) was performed for information only (see Plot # 5).

### 2.6.4. Test results:

Recorded Fundamental frequency was 91.96 dB $\mu$ V/m (see Plot # 2).

The result was found below specified limit.

All received spurious emissions were found at least 20 dB below specified limits.

Test results are presented in Plot # 3 – for Tx mode and Plot # 4– for Rx mode.

Frequency MHz	AVG Ampl. dB $\mu$ V/m	AVG limit, dB $\mu$ V/m	Margin, dB	Reference Plot
1829.995	43.6	54.0	10.4	Plot # 3

### 2.6.5. Test summary:

The tested unit meets the standard requirement.

**Test Report No.:** 8412305148

**Page 14 of 24 Pages**

**Title:** Test on WristClinic

**Model:** AIO-67 (915 MHz)

16:46:32 APR 20, 2004  
Medic4all EUT-A10-67 915 MHz

ACTV DET: PEAK  
MEAS DET: PEAK QP AVG  
MKR 915.015 MHz  
91.96 dB $\mu$ V/m

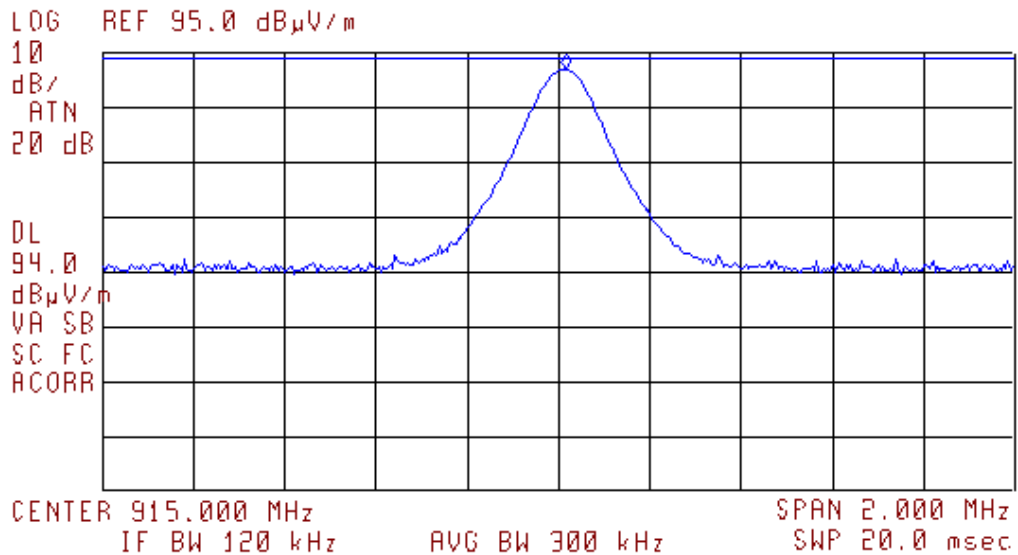

**Plot # 2. Field strength of Fundamental frequency**

13:30:20 MAY 10, 2004  
Medic4all EUT-A10 B7 915 MHz

ACTV DET: PEAK  
MEAS DET: PEAK QP AVG  
MKR 1.829 GHz  
42.76 dB $\mu$ V/m

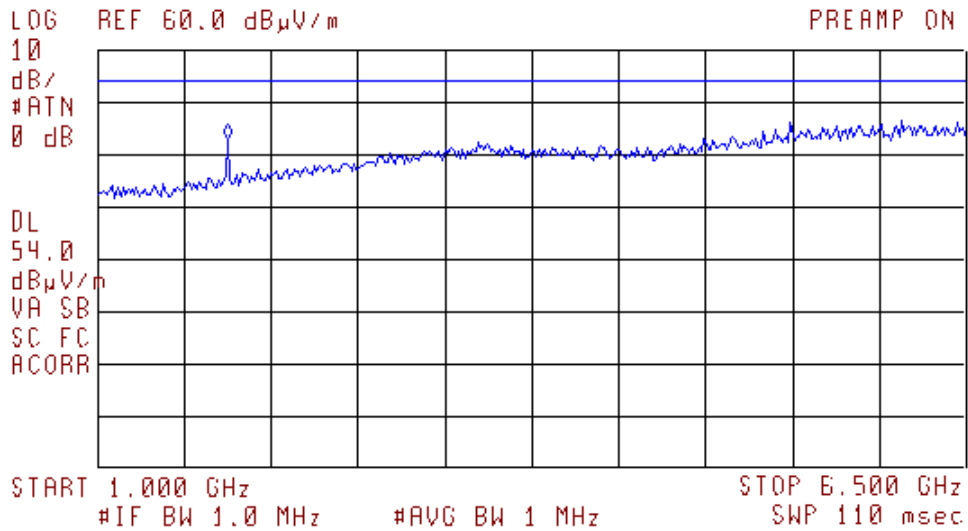

**Plot # 3. Tx mode. Spurious emissions  
Frequency range from 1000 MHz to 6500 MHz**



**Test Report No.: 8412305148**

**Page 16 of 24 Pages**

**Title: Test on WristClinic**

**Model: AIO-67 (915 MHz)**

13:33:48 MAY 10, 2004 Rx mode  
Medic4all EUT-A10 67 915 MHz

ACTV DET: PEAK  
MEAS DET: PEAK QP AVG  
MKR 6.362 GHz  
46.67 dB $\mu$ V/m

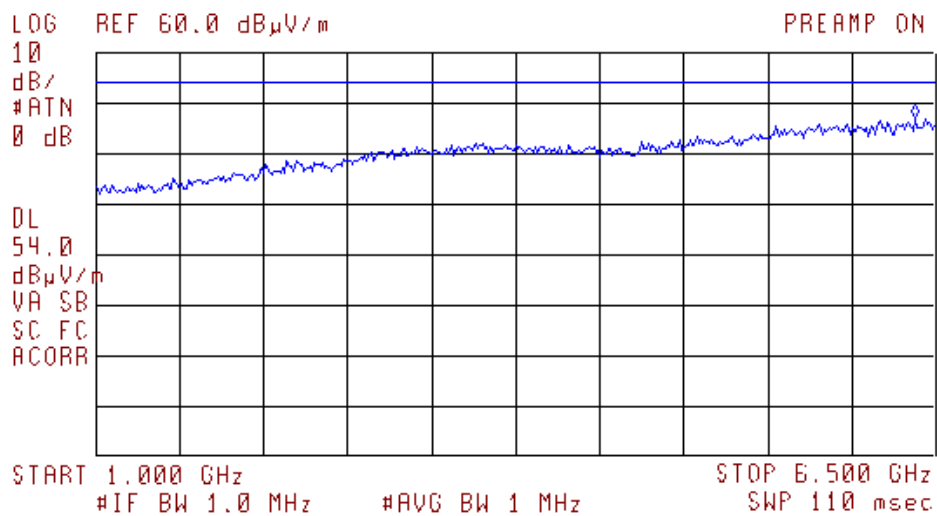

**Plot # 4. Rx mode. Spurious emissions  
Frequency range from 1000 MHz to 6500 MHz**

**Test Report No.: 8412305148**

**Page 17 of 24 Pages**

**Title: Test on WristClinic**

**Model: AIO-67 (915 MHz)**

11:04:58 MAY 23, 2004  
Medic4all EUT-A10 B7 915 MHz

ACTV DET: PEAK  
MEAS DET: PEAK QP AVG  
MKR $\Delta$  -55.5 kHz  
.64 dB

LOG REF 90.0 dB $\mu$ V/m

10  
dB/  
ATN  
10 dB

VA SB  
SC FC  
ACORR

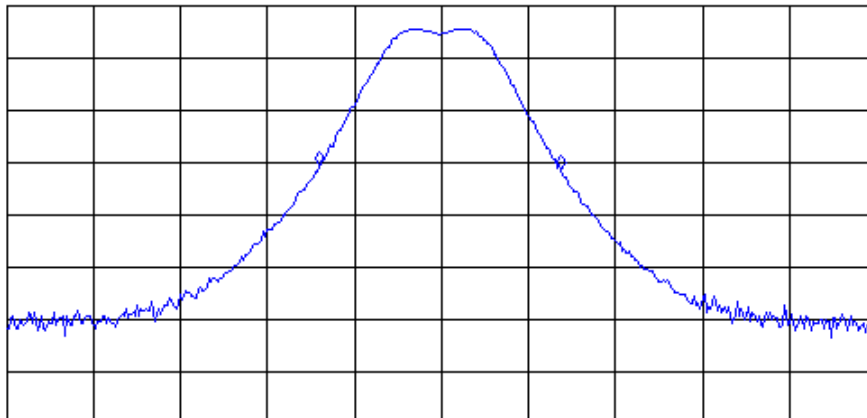

CENTER 915.0000 MHz

SPAN 200.0 kHz

#IF BW 10 kHz

#AVG BW 30 kHz

#SWP 200 msec

**Plot # 5. Range of modulation bandwidth.**

**Test Report No.:** 8412305148

**Page 18 of 24 Pages**

**Title:** Test on WristClinic

**Model:** AIO-67 (915 MHz)

### 3. Test summary

Parameter	FCC Part 15 Reference paragraph	Comply/not comply with the requirements
Radiated emission Frequencies range of 30 -1000 MHz	Subpart B Section 15.109 Class B	Comply
	Subpart C Section 15.209	Comply
Test of field strength of emission from intentional radiators	"Radiated Emission Limits, Additional Provisions"; Section 15.249 (a).	Comply
Test of field strength of emission from intentional radiators, restricted bands	Subpart C Section 15.205	Comply

Telematics Laboratory

22 July 2004





---

Name: Eng. Yuri Rozenberg  
Position: Head of EMC Branch



---

Name: Michael Feldman  
Position: Test Technician



---

Written by: Rotenfeld Mariya  
Position: Technical Writer

#### 4. Appendix 1. Test equipment used

All measurements equipment is on SII calibration schedule with a recalibration interval not exceeding one year.

##### **FCC Part 15 Subpart B Section 15.109 / Subpart C Section 15.209**

Instrument	MFR	Model	Serial No.	Last calibration date	Next calibration date
EMI Receiver	HP	8546A+85460A	SII 4068	11/03	11/04
LISN 9 kHz – 30 MHz	FCC	LISN- 50/250-32-4-16	SII 5023	05/04	05/05
Transient limiter 0.009-200 MHz	HP	11947A	31074A310 5	05/04	05/05
Antenna Biconilog 30 – 2000 MHz	Schaffner- Chase	CBL6112B	S/N 2531	12/03	12/04
Antenna Mast	R&S	HCM	100002	N/A	N/A
Metallic turntable	R&S	HCT12	100001	N/A	N/A
Positioning controller	R&S	HCC	100002	N/A	N/A

##### **FCC Part 15 Subpart C Sections 15.249 and 15.205**

Instrument	MFR	Model	Serial No.	Last calibration date	Next calibration date
EMI Receiver 10 kHz - 26.5 GHz	HP	E7405A	SII 4944	01/04	01/05
Antenna Bilog 30-2000 MHz	Schaffner- Chase	CBL6112B	SII5119	10/03	10/04
Antenna Double Ridge, 1-18 GHz	EMCO	3115	SII4873	12/03	12/04

## 5. Appendix 2: Antenna Factor and Cable Loss

### Cable Loss (10m cable + Mast)

Point	Frequency (MHz)	Cable Loss (dB)	Point	Frequency (MHz)	Cable Loss (dB)
1	30	0.53	21	1000	3.68
2	50	0.75	22	1100	3.82
3	100	1.08	23	1200	4.07
4	150	1.39	24	1300	4.24
5	200	1.61	25	1400	4.43
6	250	1.752	26	1500	4.6
7	300	2.00	27	1600	4.7
8	350	2.15	28	1700	4.85
9	400	2.26	29	1800	4.98
10	450	2.383	30	1900	5.19
11	500	2.52	31	2000	5.34
12	550	2.606	32	2100	5.51
13	600	2.75	33	2200	5.69
14	650	2.856	34	2300	5.89
15	700	3.06	35	2400	6.07
16	750	3.201	36	2500	6.22
17	800	3.27	37	2600	6.28
18	850	3.38	38	2700	6.41
19	900	3.46	39	2800	6.53
20	950	3.55	40	2900	6.84

**Table 4. Antenna Factor**

**For Biconilog Antenna, Model Number: CBL-6112B, S/N: 2531  
10 m Calibration**

Horizontal Polarization				Vertical Polarization			
Frequency (MHz)	Antenna Factor (dB/m)	Frequency (MHz)	Antenna Factor (dB/m)	Frequency (MHz)	Antenna Factor (dB/m)	Frequency (MHz)	Antenna Factor (dB/m)
30	19.7	725	19.7	30	17.6	725	19.8
40	13.8	750	20.1	40	16.1	750	20.0
50	8.5	775	20.1	50	8.2	775	20.0
60	6.3	800	20.1	60	6.0	800	20.1
70	6.4	825	20.3	70	6.2	825	20.3
80	7.2	850	20.5	80	7.7	850	20.6
90	9.1	875	20.7	90	9.2	875	20.8
100	10.8	900	20.7	100	10.6	900	20.9
110	11.7	925	20.9	110	11.4	925	21.0
120	12.0	950	21.0	120	11.7	950	21.2
130	11.8	975	21.4	130	11.8	975	21.3
140	11.3	1000	21.5	140	11.3	1000	21.4
150	10.5	1050	22.0	150	10.4	1050	21.9
160	10.0	1100	22.2	160	9.8	1100	22.2
170	9.6	1150	22.7	170	9.4	1150	22.6
180	9.2	1200	23.2	180	9.4	1200	23.1
190	9.0	1250	23.6	190	9.6	1250	23.5
200	9.3	1300	24.0	200	9.9	1300	23.8
225	9.8	1350	24.1	225	10.5	1350	24.0
250	12.7	1400	24.6	250	12.6	1400	24.3
275	12.9	1450	24.9	275	13.2	1450	24.7
300	13.3	1500	25.1	300	13.4	1500	25.0
325	13.8	1550	25.2	325	13.8	1550	25.2
350	14.6	1600	25.4	350	14.6	1600	25.3
375	15.0	1650	25.9	375	15.1	1650	25.8
400	15.9	1700	26.1	400	16.0	1700	26.0
425	16.6	1750	26.4	425	16.7	1750	26.2
450	16.8	1800	26.4	450	16.7	1800	26.4
475	17.5	1850	26.7	475	17.4	1850	26.7
500	17.7	1900	27.3	500	17.7	1900	27.3
525	18.0	1950	27.6	525	18.0	1950	27.3
550	19.3	2000	27.6	550	19.1	2000	27.7
575	19.4			575	19.1		
600	19.3			600	19.3		
625	19.7			625	19.5		
650	19.6			650	19.5		
675	19.5			675	19.5		
700	19.4			700	19.5		

**Gain and Antenna Factor for Double Ridged Guide Antenna**

Model Number: 3115, S/N 5802, manufactured by EMC Test Systems  
 1.0 meter calibration, Polarization: Horizontal, Calibrated on 30/Dec/03

Frequency (MHz)	Antenna Factor (dB/m)	Gain Numeric	Gain (dBi)
1,000.00	24.30	3.90	5.91
1,500.00	25.50	6.65	8.23
2,000.00	27.77	7.01	8.46
2,500.00	28.83	8.59	9.34
3,000.00	30.68	8.08	9.07
3,500.00	31.84	8.41	9.25
4,000.00	33.14	8.14	9.11
4,500.00	32.61	11.66	10.67
5,000.00	34.17	10.04	10.02
5,500.00	34.63	10.92	10.38
6,000.00	35.15	11.54	10.62
6,500.00	35.14	13.59	11.33
7,000.00	35.86	13.34	11.25
7,500.00	37.21	11.22	10.50
8,000.00	37.64	11.57	10.63
8,500.00	38.18	11.52	10.62
9,000.00	38.17	12.96	11.13
9,500.00	38.37	13.77	11.39
10,000.00	38.73	14.05	11.48
10,500.00	38.79	15.30	11.85
11,000.00	38.98	16.06	12.06
11,500.00	39.77	14.63	11.65
12,000.00	39.58	16.64	12.21
12,500.00	39.51	18.36	12.64
13,000.00	40.87	14.50	11.61
13,500.00	41.46	13.65	11.35
14,000.00	42.04	12.85	11.09
14,500.00	41.42	15.90	12.01
15,000.00	39.78	24.84	13.95
15,500.00	38.55	35.25	15.47
16,000.00	38.90	34.65	15.40
16,500.00	39.84	29.65	14.72
17,000.00	42.09	18.76	12.73
17,500.00	45.12	9.89	9.95
18,000.00	46.90	6.94	8.42

**Gain and Antenna Factor for Double Ridged Guide Antenna**

Model Number: 3115, S/N 5802, manufactured by EMC Test Systems  
 1.0 meter calibration, Polarization: Vertical, Calibrated on 30/Dec/03

Frequency (MHz)	Antenna Factor (dB/m)	Gain Numeric	Gain (dBi)
1,000.00	24.08	4.10	6.13
1,500.00	25.63	6.46	8.10
2,000.00	27.88	6.85	8.35
2,500.00	29.01	8.23	9.15
3,000.00	30.65	8.12	9.10
3,500.00	32.01	8.09	9.08
4,000.00	33.07	8.28	9.18
4,500.00	32.81	11.14	10.47
5,000.00	34.09	10.22	10.10
5,500.00	34.84	10.43	10.18
6,000.00	34.97	12.02	10.80
6,500.00	35.34	12.98	11.13
7,000.00	36.33	11.98	10.78
7,500.00	37.54	10.41	10.17
8,000.00	37.82	11.11	10.46
8,500.00	38.28	11.28	10.52
9,000.00	38.33	12.48	10.96
9,500.00	38.55	13.22	11.21
10,000.00	38.76	13.98	11.45
10,500.00	38.65	15.79	11.98
11,000.00	39.06	15.76	11.97
11,500.00	39.63	15.10	11.79
12,000.00	39.52	16.87	12.27
12,500.00	39.57	18.09	12.57
13,000.00	40.80	14.74	11.69
13,500.00	41.76	12.77	11.06
14,000.00	42.10	12.67	11.03
14,500.00	41.49	15.66	11.95
15,000.00	40.02	23.49	13.71
15,500.00	38.40	36.41	15.61
16,000.00	38.23	40.40	16.06
16,500.00	39.71	30.55	14.85
17,000.00	41.86	19.75	12.96
17,500.00	44.89	10.42	10.18
18,000.00	46.26	8.05	9.06



## 6. Appendix 3. Test configuration illustrations



**Photo 5. Test setup with Thermometer on Open site**