

# HILTI

# PR 35

Bedienungsanleitung

de

Operating instructions

en

Mode d'emploi

fr

CE

1

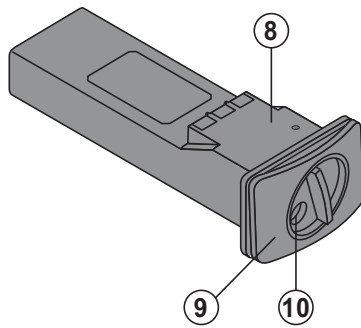
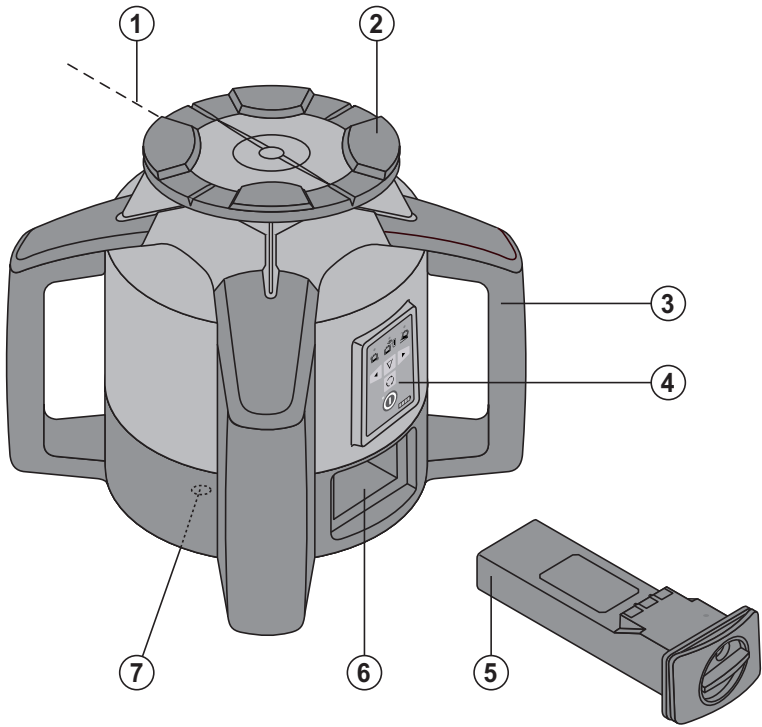

2

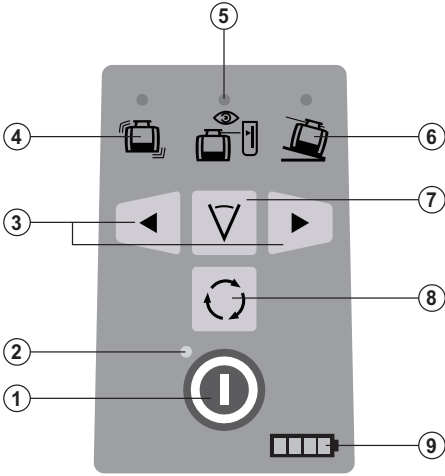

3

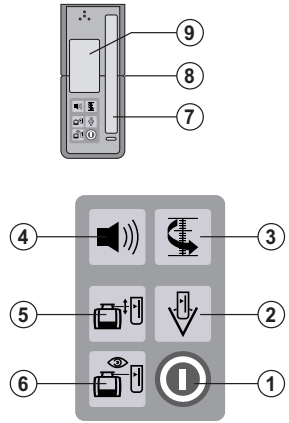

4

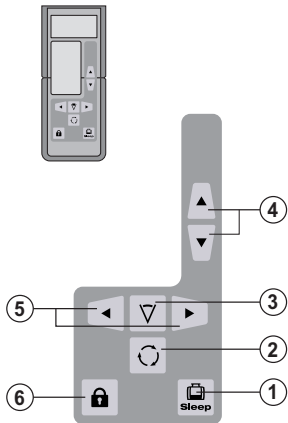

5

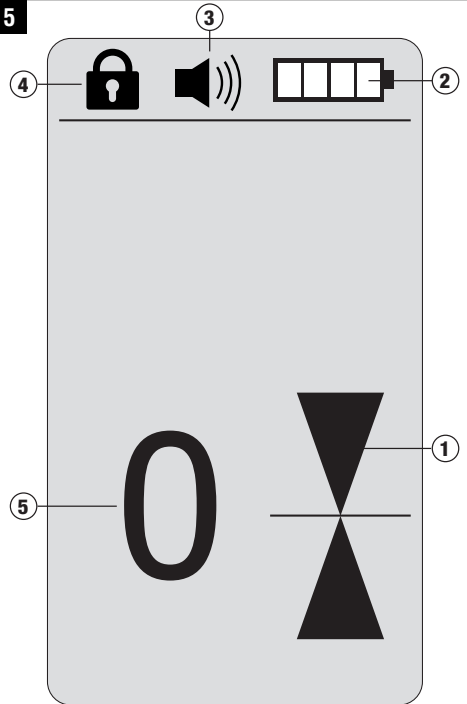

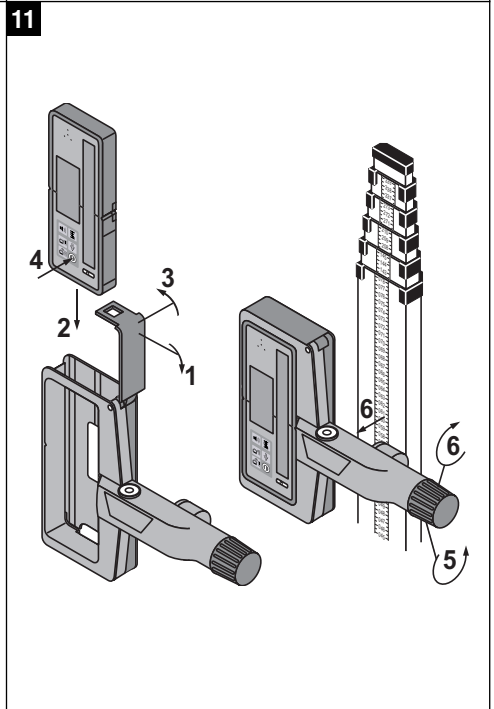
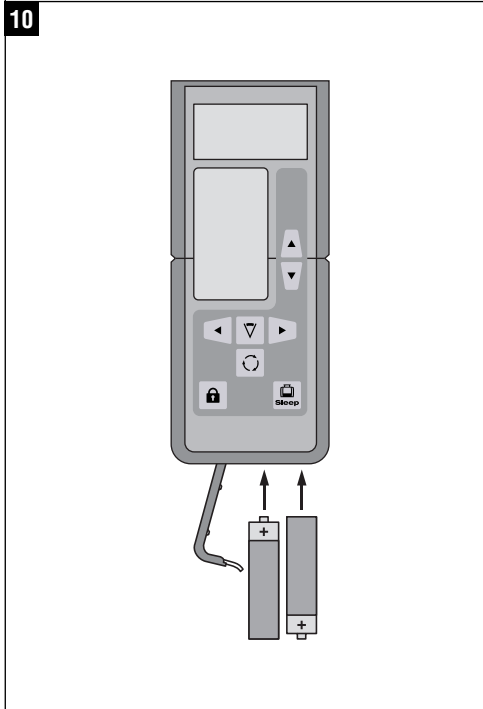
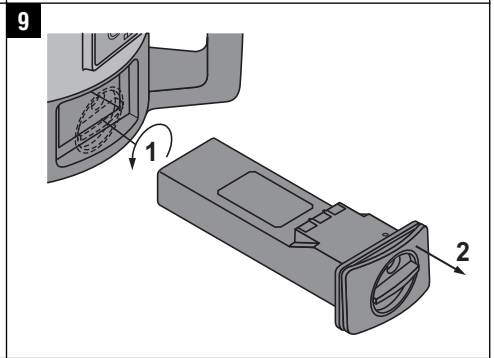
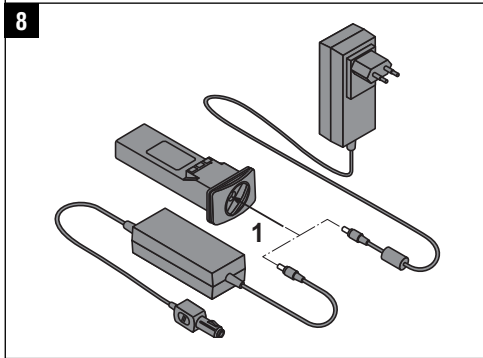
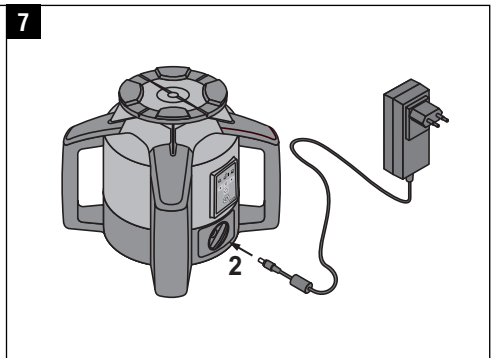
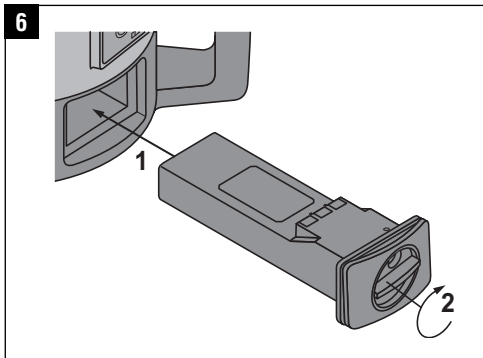

12

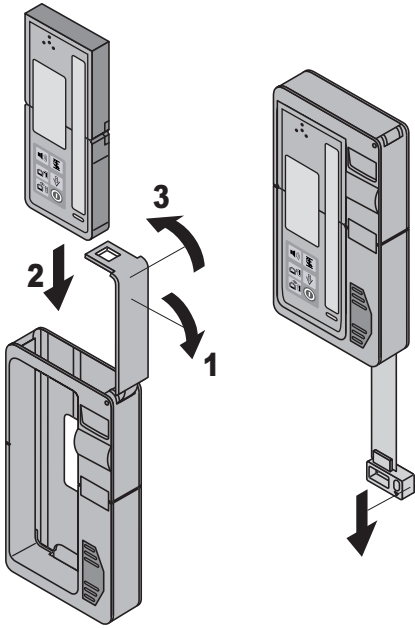

13

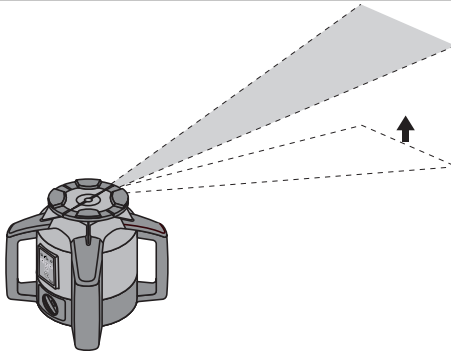

14

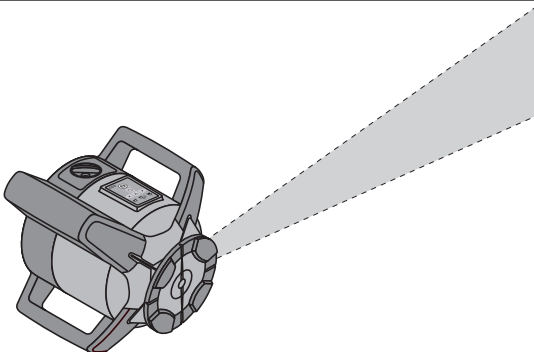

15

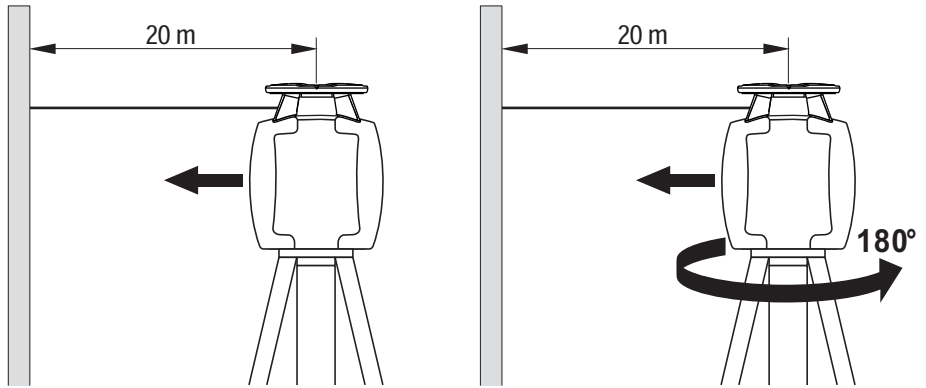

16

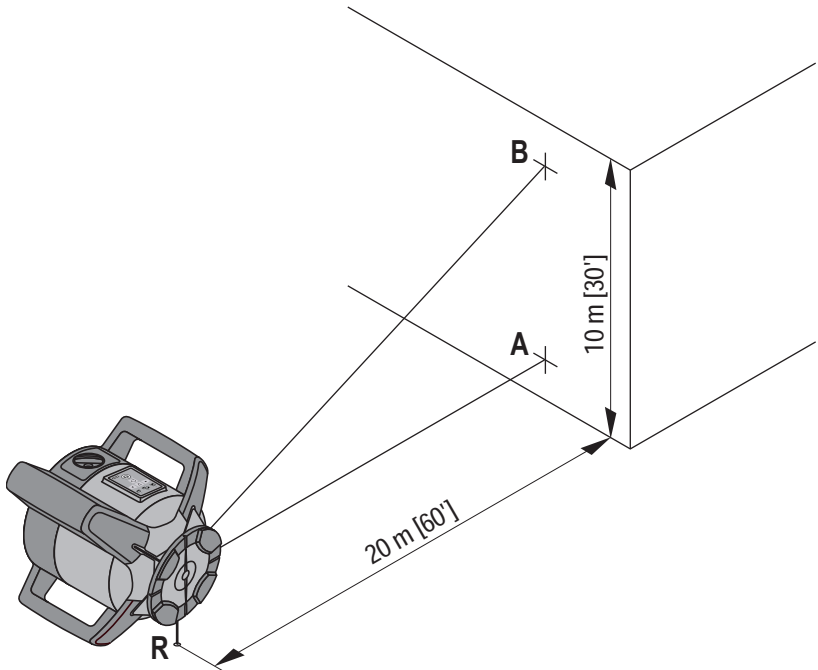

17

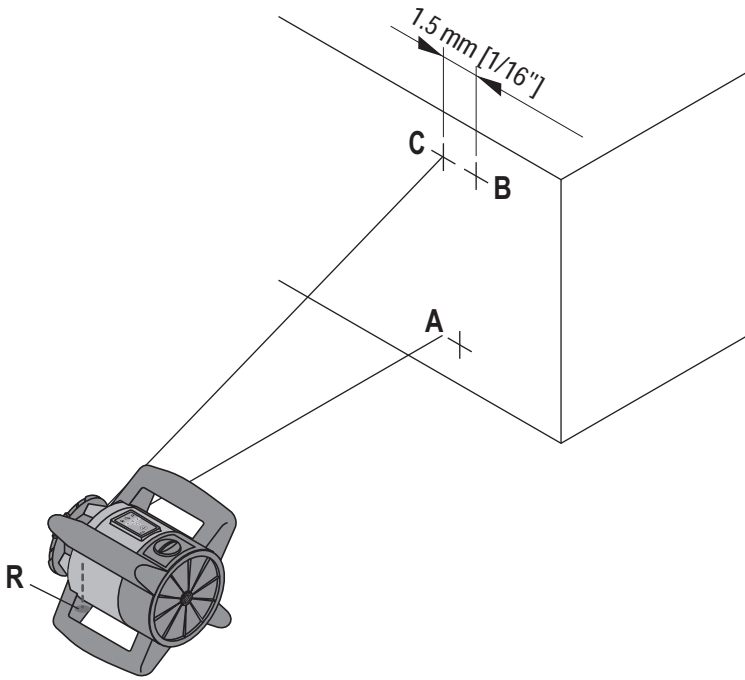

# HILTI

## Hilti Corporation

LI-9494 Schaan

Tel.: +423 / 234 21 11

Fax: +423 / 234 29 65

[www.hilti.com](http://www.hilti.com)





## ORIGINAL OPERATING INSTRUCTIONS

# PR 35 rotating laser

en

***It is essential that the operating instructions are read before the tool is operated for the first time.***

***Always keep these operating instructions together with the tool.***

***Ensure that the operating instructions are with the tool when it is given to other persons.***

Contents	Page
1. General information	2
2. Description	2
3. Accessories	5
4. Technical data	5
5. Safety instructions	7
6. Before use	9
7. Operation	10
8. Care and maintenance	14
9. Troubleshooting	15
10. Disposal	16
11. Manufacturer's warranty - tools	17
12. EC declaration of conformity	17

**1** These numbers refer to the corresponding illustrations. The illustrations can be found on the fold-out cover pages. Keep these pages open while studying the operating instructions.

In these operating instructions, the designation "the tool" or "the rotating laser" always refers to the Hilti PR 35. The designation "remote control / laser receiver" always refers to the Hilti PRA 35.

### Rotating laser **1**

- ① Laser beam (plane of rotation)
- ② Rotating head
- ③ Grip
- ④ Control panel

- ⑤ Battery
- ⑥ Battery compartment
- ⑦ Base plate with 5/8" thread

### Rotating laser control panel **2**

- ① On / off button
- ② Auto-leveling LED
- ③ Direction buttons
- ④ Shock warning deactivation LED
- ⑤ Monitoring mode LED
- ⑥ Slope LED
- ⑦ Line function button
- ⑧ Speed of rotation button
- ⑨ Battery status

### PRA 35 control panel (on the front of the receiver) **3**

- ① On / off button
- ② Special line function
- ③ Units button
- ④ Volume button
- ⑤ Automatic alignment button
- ⑥ Monitoring mode button
- ⑦ Receiving area
- ⑧ Marking notch
- ⑨ Display

### PRA 35 control panel (on the rear of the remote control) **4**

- ① Sleep mode button
- ② Speed of rotation button
- ③ Line function button
- ④ Direction buttons (up/down)
- ⑤ Direction buttons (left/right)
- ⑥ Button lock

### PRA 35 display **5**

- ① Position of the receiver relative to the height of the laser plane
- ② Battery status
- ③ Signal tone volume
- ④ Button lock
- ⑤ Distance of receiver from laser plane

## 1. General information

### 1.1 Safety notices and their meaning

#### DANGER

en

Draws attention to imminent danger that could lead to serious bodily injury or fatality.

#### WARNING

Draws attention to a potentially dangerous situation that could lead to serious personal injury or fatality.

#### CAUTION

Draws attention to a potentially dangerous situation that could lead to slight personal injury or damage to the equipment or other property.

#### NOTE

Draws attention to an instruction or other useful information.

### 1.2 Explanation of the pictograms and other information

#### Symbols



Read the operating instructions before use.



General warning



Return waste material for recycling.



Do not look into the beam.

#### Symbol for Laser Class II / Class 2



Laser class II according to CFR 21, § 1040 (FDA)



Laser class 2 according to EN 60825:2008

### Type identification plate

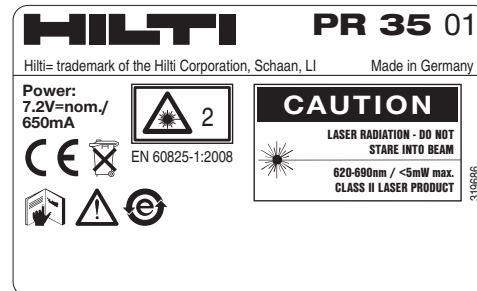

PR 35

#### Location of identification data on the tool

The type designation and serial number can be found on the type identification plate on the tool. Make a note of this data in your operating instructions and always refer to it when making an enquiry to your Hilti representative or service department.

Type: \_\_\_\_\_

Generation: 01 \_\_\_\_\_

Serial no.: \_\_\_\_\_

## 2. Description

### 2.1 Use of the product as directed

The tool is designed to be used to determine, transfer and check levels, verticals, slopes and right angles. Examples of its uses are: transferring datums and height marks, determining right angles for walls, vertical alignment on reference points and setting out slopes.

Use of tools or AC adapters which show visible signs of damage is not permissible. Operation outdoors or in damp conditions in "Charging during operation mode" is not permissible.

To avoid the risk of injury, use only genuine Hilti accessories and insert tools.

Observe the information printed in the operating instructions concerning operation, care and maintenance.

Take the influences of the surrounding area into account. Do not use the appliance where there is a risk of fire or explosion.

Modification of the tool is not permissible.

## **2.2 PR 35 rotating laser**

The Hilti PR 35 is a rotating laser tool with a visible rotating laser beam and a reference beam set at 90° to the main beam. The PR 35 can be used for alignment in the vertical, horizontal and inclined planes.

en

## **2.3 Features**

The tool makes it possible for a single person to level or align in any plane quickly and with great accuracy. The tool features automatic leveling (within 10° (±5°)). The tool levels itself automatically after switching on. The laser beam is emitted only when the specified accuracy has been achieved. LEDs indicate the tool's current operating status. The tool is powered by a rechargeable Li-ion battery which can be charged while the tool is in operation. The PR 35 has a number of useful features: Monitoring mode, auto-alignment, sleep mode and button lock.

## **2.4 PRA 35 combined remote control and laser receiver**

The PRA 35 is a combined remote control unit and laser receiver. It can be used to control the PR 35 rotating laser over great distances. The PRA 35 also serves as a laser receiver and can thus be used to detect and indicate the laser beam at great distances.

## **2.5 Digital distance measurement display**

The PRA 35 shows the distance between the laser plane and the marking notch on the PRA 35 in the digital display. This allows the user to determine the exact position of the receiver relative to the laser plane, with millimeter accuracy, in a single operation.

## **2.6 Speed of rotation / line function**

3 speeds of rotation are available for use (300, 600, 1200 /min). It is possible to switch between the individual functions such as rotation and line functions. This is possible with the PR 35 rotating laser and with the PRA 35.

The line function improves laser beam visibility and limits the laser beam to a certain working area.

## **2.7 Automatic alignment and monitoring**

Using the PR 35 and the PRA 35, a single person can align the laser plane automatically with a certain point with great accuracy. When required, the laser plane can be checked at regular intervals with the aid of the monitoring function and the PRA 35 in order to avoid possible deviations due to temperature fluctuations, wind or similar.

## **2.8 Digital slope display with patented electronic axis alignment**

The digital slope display can indicate a slope of up to 15%. This makes it possible to set out and check slopes without having to make any calculations.

## **2.9 Shock warning**

The tool goes into warning mode if it is knocked off level (due to vibration or impact) while in operation: all LEDs blink and the laser switches off (the laser head no longer rotates).

## 2.10 Automatic cut-out

The laser does not switch on and all LEDs blink if the tool is set up outside its self-leveling range or movement is blocked mechanically.

After switching the tool on, the shock warning only becomes active 1 minute after completion of leveling. If a button is pressed within this time (before 1 minute has elapsed), the 1 minute delay before activation begins again.

en

## 2.11 Items supplied

- 1 PR 35 rotating laser
- 1 PRA 35 remote control / laser receiver
- 1 PRA 80 receiver holder
- 1 PR 35 operating instructions
- 1 Target plate
- 1 Manufacturer's certificate
- 1 PRA 84 Li-ion battery
- 1 PRA 85 AC adapter
- 1 Hilti toolbox

## 2.12 Operating status indicators

Operating status is indicated as follows: auto-leveling LED, battery status LED, shock warning LED and slope LED.

## 2.13 LED indicators

Auto-leveling LED (green)	The green LED blinks.	The tool is in the leveling phase.
	The green LED lights constantly.	The tool has leveled itself / is operating normally.
Shock warning LED (orange)	The orange LED blinks.	After switching on, the shock warning mode is not immediately active (delay of approx. 1 minute).
	The orange LED lights constantly.	Shock warning mode is deactivated.
Monitoring LED (orange)	The LED lights orange.	The tool is in monitoring mode.
Slope LED (orange)	The orange LED blinks.	Alignment in the sloping plane.
	The orange LED lights constantly.	Slope mode is active.
Several LEDs light	2 LEDs blink orange.	The tool is in axis alignment (slope) mode.
All LEDs	All LEDs blink	The tool has been bumped, knocked off level or is exhibiting some other error.

## 2.14 Charge status of the Li-ion battery during operation

LEDs light constantly	LEDs blink	Charge status C
LED 1,2,3,4	-	$C \geq 75\%$
LED 1,2,3	-	$50\% \leq C < 75\%$
LED 1,2	-	$25\% \leq C < 50\%$
LED 1	-	$10\% \leq C < 25\%$
-	LED 1	$C < 10\%$

## 2.15 Charge status of the Li-ion battery during charging while inserted in the tool

LEDs light constantly	LEDs blink	Charge status C
LED 1,2,3,4	-	C = 75 %
LED 1,2,3	LED 4	C ≥ 75%
LED 1,2	LED 3	50 % ≤ C < 75 %
LED 1	LED 2	25 % ≤ C < 50 %
-	LED 1	C < 25 %

en

## 2.16 Charge status of the Li-ion battery during charging while not inserted in the tool

If the red LED lights constantly, the battery is being charged.

If the red LED doesn't light, the battery is fully charged.

## 3. Accessories

PRA 35 remote control / laser receiver	
Laser receiver	PRA 38, PRA 30/31
Target plate	PRA 50/51
Wall mount	PRA 70/71
Slope calculator	PRA 52
Slope adapter	PRA 78
Car charging connector	PRA 86
Height transfer device	PRA 81
AC adapter	PRA 85
Battery	PRA 84
Vertical angle	PRA 770
Batter board receiver holder	PRA 751
Batter board adapter	PRA 750
Facade adapter	PRA 760
Various tripods	PUA 20, PUA 30, PA 921, PA 931/2
Telescopic staffs	PA 960, PUA 50, PUA 55/56

## 4. Technical data

Right of technical changes reserved.

### PR 35

PR 35 receiving range (diameter)	Typical distance with PRA 35: 2...300 m (6...900 ft)
Range of remote control (circle diameter)	Typical distance with PRA 35: 0...100 m (0...300 ft)
Accuracy	0.75 mm per 10 m horizontal distance (77° F, 1/4" in 100 ft) at a temperature of 25°C
Plumb beam	Continuous, perpendicular to the plane of rotation
PR 35 laser class	Class 2, visible, 620-690 nm / Po < 4.85 mW, ≥ 300 /min (EN 60825-1:2008 / IEC 825 - 1:2008); class II (CFR 21 § 1040 (FDA))

en

Speed of rotation	300, 600, >1200 /min
Slope range	15% (8.6°)
Self-leveling range	x=13.6° (+5°, -8.6°); y=10° (±5°)
Power source	7.2V/ 4.5 Ah Li-ion battery
Battery life	Temperature +20°C (+68°F), Li-ion battery: ≥ 30 h
Operating temperature range	-20...+50°C (-4°F to 122°F)
Storage temperature range (dry)	-25...+60°C (-13°F to 140°F)
Protection class	As per IP 56 (in accordance with IEC 529)
Tripod thread	5/8" X 11
Weight (incl. PRA 84)	2.4 kg (5.3 lbs)
Dimensions (L x W x H)	252 mm X 252 mm X 209 mm (10" x 10" x 8")

**PRA 35**

Detection range (area diameter)	2...300 m (6 to 1000 ft)
Signal tone generator	3 volume levels plus mute setting
Liquid crystal display	On both sides
Indicator range, distance from zero	± 50 mm (± 2 in)
Laser plane indication accuracy	± 0.5 mm (± 0.02 in)
Width of receiving area	120 mm (5 in)
Center indication from top edge of casing	75 mm (3 in)
Marking notches	On both sides
Automatic power-off	When no beam is detected: 15 min
Dimensions	160 mm X 67 mm X 24 mm
Weight (including batteries)	0.25 kg (0.6 lbs)
Power source	2 AA batteries
Battery life (alkaline-manganese)	Temperature +20°C (+68°F): 40 h
Operating temperature range	-20...+50°C (-4 °F to 122 °F)
Storage temperature range	-25...+60°C (-13 °F to 140 °F)
Protection class	IP 56 in accordance with IEC 529

**PRA 84 Li-ion battery**

Rated voltage (normal mode)	7.2 V
Maximum voltage (during operation or during charging while in operation)	13 V
Rated current	160 mAh
Charging time	130 min, at 25 C
Operating temperature range	-20...+50°C (-4°F to 122°F)
Storage temperature range (dry)	-25...+60°C (-13°F to 140°F)
Charging temperature range (also for charging during operation)	+0...+40°C (32° to +104°F)
Weight	0.3 kg (0.67 lbs)
Dimensions (L x W x H)	160 mm X 45 mm X 36 mm (6.3" x 1.8" x 1.4")

**PRA 85 AC adapter**

AC supply	115...230 V
AC frequency	47...63 Hz

Rated power	40 W
Rated voltage	12 V
Operating temperature range	+0...+40°C (32°F to +104°F)
Storage temperature range (dry)	-25...+60°C (-13°F to 140°F)
Weight	0.23 kg (0.51 lbs)
Dimensions (L x W x H)	110 mm X 50 mm X 32 mm (4.3" x 2" x 1.3")

en

## 5. Safety instructions

### 5.1 Basic information concerning safety

**In addition to the information relevant to safety given in each of the sections of these operating instructions, the following points must be strictly observed at all times.**

### 5.2 General safety rules

- Do not render safety devices ineffective and do not remove information and warning notices.**
- Keep laser tools out of reach of children.**
- Failure to follow the correct procedures when opening the tool may cause emission of laser radiation in excess of class 2. **Have the tool repaired only at a Hilti Service Center.**
- Take the influences of the surrounding area into account. Do not use the tool where there is a risk of fire or explosion.**
- (Statement in accordance with FCC §15.21): Changes or modifications not expressly approved by the manufacturer can void the user's authority to operate the equipment.

### 5.3 Proper organization of the work area

- Secure the area in which you are working and take care to avoid directing the beam towards other persons or towards yourself when setting up the tool.**
- Avoid unfavorable body positions when working from ladders. Make sure you work from a safe stance and stay in balance at all times.**
- Measurements taken through panes of glass or other objects may be inaccurate.
- Ensure that the tool is set up on a steady, level surface (not subject to vibration).**
- Use the tool only within its specified limits.**
- Check that your PR 35 is responding only to your PRA 35 and not to other PRA 35s that may be in use on the jobsite.

### 5.3.1 Electromagnetic compatibility

Although the tool complies with the strict requirements of the applicable directives, Hilti cannot entirely rule out the possibility of the tool being subject to interference caused by powerful electromagnetic radiation, leading to incorrect operation. Check the accuracy of the tool by taking measurements by other means when working under such conditions or if you are unsure. Likewise, Hilti cannot rule out the possibility of interference with other devices (e.g. aircraft navigation equipment).

### 5.3.2 Laser classification for laser class II appliances

The tool complies with Laser Class 2 in accordance with IEC825-1:2008 / EN60825-1:2008 and Class II in accordance with CFR 21 § 1040 (FDA). This tool may be used without need for further protective measures. The eyelid closure reflex protects the eyes when a person looks into the beam unintentionally for a brief moment. This eyelid closure reflex, however, may be negatively affected by medicines, alcohol or drugs. Nevertheless, as with the sun, one should not look directly into sources of bright light. Do not direct the laser beam toward persons.

### 5.4 General safety rules



- Check the condition of the tool before use. If the tool is found to be damaged, have it repaired at a Hilti service center.**
- The user must check the accuracy of the tool after it has been dropped or subjected to other mechanical stresses.**

en

- c) When the tool is brought into a warm environment from very cold conditions, or vice-versa, allow it to become acclimatized before use.
- d) If mounting on an adapter, check that the tool is screwed on securely.
- e) Keep the laser exit aperture clean to avoid measurement errors.
- f) Although the tool is designed for the tough conditions of jobsite use, as with other optical and electronic instruments (e.g. binoculars, spectacles, cameras) it should be treated with care.
- g) Although the tool is protected to prevent entry of dampness, it should be wiped dry each time before being put away in its transport container.
- h) Check the tool before using it for important measuring work.
- i) Check the accuracy of the measurements several times during use of the tool.
- j) Use the AC adapter only for connecting to the AC supply.
- k) Check to ensure that the tool and AC adapter do not present an obstacle that could lead to a risk of tripping and personal injury.
- l) Ensure that the workplace is well lit.
- m) Avoid body contact with earthed or grounded surfaces, such as pipes, radiators, ranges and refrigerators. There is an increased risk of electric shock if your body is earthed or grounded.
- n) Check the condition of the extension cord and replace it if damage is found. Do not touch the AC adapter if the extension cord or AC adapter are damaged while working. Disconnect the supply cord plug from the power outlet. Damaged supply cords or extension cords present a risk of electric shock.
- o) Do not expose the supply cord to heat, oil or sharp edges.
- p) Never operate the AC adapter when it is dirty or wet. Dust (especially dust from conductive materials) or dampness adhering to the surface

of the AC adapter may, under unfavorable conditions, lead to electric shock. Dirty or dusty tools should thus be checked at a Hilti Service Center at regular intervals, especially if used frequently for working on conductive materials.

- q) Avoid touching the contacts.

#### 5.4.1 Battery tool use and care

- a) Check that the tool is switched off before fitting the battery. Use only the Hilti battery approved for use with this tool.
- b) Do not expose batteries to high temperatures or fire. This presents a risk of explosion.
- c) Do not disassemble, squash or incinerate batteries and do not subject them to temperatures over 75°C. A risk of fire, explosion or injury through contact with caustic substances may otherwise result.
- d) Avoid ingress of moisture. Moisture may cause a short circuit resulting in a risk of burning injury or fire.
- e) Do not use batteries other than those approved for use with the applicable tool or appliance. Use of other batteries or use of the battery for purposes for which it is not intended presents a risk of fire and explosion.
- f) Observe the special instructions applicable to the transport, storage and use of Li-ion batteries.
- g) Avoid short-circuiting the battery. Before inserting the battery in the tool, check that the terminals of the battery and the tool are free from foreign objects. Short-circuiting the battery terminals presents a risk of fire, explosion or contact with caustic substances.
- h) Do not charge or continue to use damaged batteries (e.g. batteries with cracks, broken parts, bent or pushed-in and/or pulled-out contacts).
- i) Use only the specified battery to power the tool and use only the PRA 85 AC adapter or PRA 86 car charging connector for charging. Failure to observe these points may result in damage to the tool.



## 6. Before use

### NOTE

The PR 35 may be powered only by the Hilti PRA 84 battery, which is manufactured in accordance with IEC 60285.

### 6.1 Charging the battery



### DANGER

Use only the Hilti battery, car charging connector and Hilti AC adapter listed under "Accessories".

#### 6.1.1 Charging a new battery for the first time

Charge the battery fully before using it for the first time.

### NOTE

Make sure the system to be charged is standing securely.

#### 6.1.2 Charging a previously used battery

Ensure that the outer surfaces of the battery are clean and dry before inserting it in the tool.

Li-ion batteries are ready for use at any time, even when only partly charged. During charging, progress is indicated by the LEDs on the tool.

### 6.2 Options for charging the battery

### DANGER

The PRA 85 AC adapter is for indoor use only. Avoid ingress of moisture.

#### 6.2.1 Charging the battery in the tool 6 7

### NOTE

When charging, check that the temperature is within the recommended charging temperature range (0 to 40°C/ 32 to 104°F).

1. Insert the battery in the battery compartment.
2. Swing the cover to the side so that the charging cord socket becomes accessible.
3. Connect the charging cord from the AC adapter or car charging connector to the battery.

4. During charging, the charge status is indicated by the battery status LEDs on the tool (the tool must be switched on).

#### 6.2.2 Charging the battery outside the tool 8

### NOTE

When charging, check that the temperature is within the recommended charging temperature range (0 to 40°C/ 32 to 104°F).

1. Remove the battery from the tool and connect it to the AC adapter or car charging connector.
2. The red LED on the battery lights while charging is in progress.

#### 6.2.3 Charging the battery while the tool is in operation 8

### CAUTION

**Avoid ingress of moisture.** Moisture may cause a short circuit resulting in a risk of burning injury or fire.

1. Swing the cover to the side so that the charging cord socket becomes accessible.
2. Connect the charging cord from the AC adapter to the battery.
3. The tool continues to operate while charging is in progress.
4. During charging, the charging status is indicated by the LEDs on the tool.

### 6.3 Battery use and care

Store the battery in a cool, dry place. Never store the battery where it is exposed to direct sunlight or sources of heat, e.g. on heaters / radiators or behind a motor vehicle windscreen. Batteries that have reached the end of their life must be disposed of safely and correctly to avoid environmental pollution.

### 6.4 Fitting the battery 6

### CAUTION

**Before inserting the battery in the tool, check that the terminals of the battery and the tool are free from foreign objects.**

en

1. Push the battery into the tool.
2. Turn the catch in a clockwise direction to the second detent (the “locked” symbol is displayed).

#### 6.5 Removing the battery

en

1. Turn the catch in a counterclockwise direction from the second detent back to the “open” position (the “unlocked” symbol is displayed).
2. Pull the battery out of the tool.

#### 6.6 Switching the tool on

Press the “On / off” button.

##### NOTE

After switching on, the tool begins the automatic leveling process (takes max. 40 seconds). After completion of the leveling process, the laser beam switches on and begins to rotate in the normal direction. When leveling in the horizontal plane the laser head rotates automatically at medium speed and, when working in the vertical plane, a reference point is projected downwards.

#### 6.7 LED indicators

Please refer to section 2 “Description”.

#### 6.8 Inserting batteries in the PRA 35

##### CAUTION

Do not use damaged batteries.

##### DANGER

Do not mix old and new batteries. Do not mix batteries of different makes or types.

##### NOTE

The PRA 35 may be powered only by batteries manufactured in accordance with the applicable international standards.

#### 6.9 Pairing

##### NOTE

In the state supplied, the PR 35 rotating laser and the PRA 35 remote control / laser receiver have not been paired. They cannot operate together until they have been paired.

The PR 35 rotating laser and the PRA 35 must be set to operate as a pair before they can be used together. Pairing the tools means that they are configured to communicate with each other. The PR 35 rotating laser then receives signals only from the PRA 35 with which it has been paired. Pairing makes it possible to work alongside other rotating lasers without risk of settings being altered inadvertently by these tools.

1. Press the “On / off” buttons on the PR 35 rotating laser and on the PRA 35 simultaneously (or on the PRA 90 if this tool is being used) and keep the buttons pressed for at least 3 seconds.

When pairing has been carried out successfully, a signal tone is emitted by the PRA 35 and all LEDs on the PR 35 rotating laser blink.

2. Switch off the tools that have been paired and then switch them on again.

The “Paired” symbol appears in the display (see “Troubleshooting” section).

## 7. Operation



#### 7.1 Switching the tool on

Press the “On / off” button.

##### NOTE

After switching on, the tool begins to level itself automatically.

#### 7.2 Working with the PRA 35

The PRA 35 is a laser receiver (front) and, at the same time, a remote control unit (rear). The remote control makes working with the rotating laser more convenient and is required in order to make use of certain functions.

### 7.2.1 Working with the laser receiver as a hand-held unit

1. Press the "On / off" button.
2. Hold the PRA 35 in the plane of the rotating laser beam.  
The laser beam is indicated by visual and audible signals.

### 7.2.2 Using the PRA 35 in the PRA 80 receiver holder

1. Open the catch on the PRA 80.
2. Place the PRA 35 in the PRA 80 receiver holder.
3. Close the catch on the PRA 80.
4. Switch the laser receiver on by pressing the "On / off" button.
5. Turn the rotating grip to the open position.
6. Fit the PRA 80 receiver holder onto the telescopic staff or leveling staff and secure it by tightening the rotating grip.
7. Hold the PRA 35 with the receiving window in the plane of the rotating laser beam.  
The laser beam is indicated by visual and audible signals.

### 7.2.3 Working with the PRA 81 height transfer device

1. Open the catch on the PRA 81.
2. Insert the PRA 35 laser receiver in the PRA 81 height transfer device.
3. Close the catch on the PRA 81.
4. Switch the PRA 35 on by pressing the "On / off" button.
5. Position the PRA 35 so that the distance display shows "0".
6. Hold the PRA 35 with the receiving window in the plane of the rotating laser beam.
7. Use the measuring tape to measure the desired distance.

### 7.2.4 Menu options

Press the "On / off" button for 2 seconds when switching the PRA 35 on.

The menu then appears in the display.

Use the measuring units button to select metric or imperial measuring units.

Use the volume button to assign the more rapid signal tone to the upper or lower area of the receiving window.

To save the settings, switch the PRA 35 off.

### 7.2.5 Setting the measuring unit

The "units" button can be used to set the desired measuring unit according to the country of use (mm / cm / off) or ( $\frac{1}{16}$ in /  $\frac{1}{4}$ in / off).

### 7.2.6 Setting the volume of the signal tone

The tool is set to "Normal" volume when switched on. The volume can be adjusted by pressing the "Signal tone" button. One of the following settings can be selected: "Low", "Normal", "High" or "Off".

### 7.2.7 Button lock and confirmation of entries

The button lock function of the PRA 35 prevents unintentional entries being made and is indicated at the upper left edge of the display on both sides of the PRA 35. The lock symbol is either open (unlocked) or closed (locked). During operation, the command must be confirmed by pressing the button again in order to rule out incorrect manipulation. This requirement for confirmation is indicated in the display but, for the sake of simplicity, is not mentioned each time in other sections of the operating instructions.

### 7.3 Basic functions of the PR 35

The basic functions are horizontal and vertical alignment plus working with slopes.

#### 7.3.1 Setting the speed of rotation

##### NOTE

The speed of rotation can be adjusted by pressing the "Speed of rotation" button (on the control panel of the rotating laser or on the PRA 35). The speeds of rotation are: 300, 600 and >1200 /min. The receiver works best at 600 /min and should not be used at speeds of >1200 /min.

#### 7.3.2 Selecting the line function

##### NOTE

When the "Line" button is pressed, the rotating laser projects a line which can be lengthened or shortened by further presses of the button.

##### NOTE

With the aid of the PRA 35 laser receiver it is also possible to stop rotation of the laser and to project a line at the position of the PRA 35. To do this, move the PRA 35 laser receiver into the plane of the laser beam and press the "Special line button".

en

### 7.3.3 Moving the laser line

The laser line can be moved to the left or right by pressing the “Direction” buttons (PR 35 or PRA 35). Holding down the button results in continuous movement and increases the speed of movement of the laser line.

## 7.4 Working in the horizontal plane 13

### 7.4.1 Setting up

1. Set up the tool in a suitable position for the application, e.g. on a tripod. The angle of the surface on which it is stood should not exceed  $10^\circ (\pm 5^\circ)$ .
2. Press the “On / off” button.
3. The laser beam switches on and the head begins to rotate at a speed of 300 /min as soon as the tool has leveled itself.

## 7.5 Working in the vertical plane 14

1. When working in the vertical plane, place the tool on its metal feet so that the control panel faces upwards. Alternatively, the rotating laser may also be mounted on a suitable tripod, wall bracket, facade adapter or batter board adapter.
2. Adjust the tool so that its vertical axis is positioned in the required direction.
3. In order to ensure that the tool’s specified accuracy can be maintained, make sure that it is set up on a level surface or mounted sufficiently level on the tripod or other accessory.
4. Press the “On / off” button.  
After the tool has leveled itself automatically, it projects a stationary laser beam vertically downwards. This projected point is the reference point and is used to position the tool.

### 7.5.1 Manual alignment

Manual alignment of the vertical plane is carried out by pressing the “Up” or “Down” buttons on the rear of the PRA 35.

### 7.5.2 Auto-alignment

Hold the PRA 35 at the point to be aligned, with the receiving side facing the PR 35, and then press the “Automatic alignment” button.

The laser plane alignment procedure then begins. A constant signal tone is emitted while this is taking place.

The search can be adjusted by pressing the “Direction” buttons.

As soon as the laser beam strikes the receiving area of the PRA 35, the beam moves to the position of the marking notch (reference plane).

A short signal tone is emitted, indicating the end of the procedure, as soon as the laser beam finds the position of the marking notch.

## 7.6 Working with slopes

### NOTE

For optimum results, check that the PR 35 is correctly aligned. This is best done by selecting 2 points each 5 m to the left and right of the tool but parallel to the tool axis. Mark the height of the horizontal plane and then, after setting the slope, mark the heights. The tool is aligned optimally only when these heights are identical at both points.

### 7.6.1 Setting up

### NOTE

The slope can be set manually, automatically, or by using the PRA 76/78 slope adapter.

1. Set up the tool in a suitable position for the application, e.g. on a tripod.
2. With the aid of the target notch on the head of the PR 35, bring the tool parallel to the inclined plane.
3. Press the “On / off” button for at least 8 seconds until the orange LED lights.
4. The laser beam switches on as soon as the tool has leveled itself. The PRA 35 can then be set to the desired slope.

### 7.6.2 Setting the slope manually

Press the “Up” and “Down” arrow buttons on the PRA 35 remote control. Pressing the arrow buttons for longer causes the values to change more quickly. The LED display on the PRA 35 shows the angle of slope.

If no button is pressed for 3 seconds, the tool will be set to the most recently displayed value.

### 7.6.3 Setting the slope automatically

### NOTE

The slope can be set automatically only when slope mode is active and when a PRA 35 laser receiver is used.

Incline the laser as described at 7.5.2, but in alignment with the inclined plane.

#### 7.6.4 Optional electronic alignment

After setting the slope as described above, alignment of the PR 35 can be optimized by Hilti's patented electronic alignment system.

1. Position the PRA 35 centrally opposite the PR 35 at the end of the inclined plane. It can be held still by hand or fixed in place with the aid of the PRA 80.
2. Switch the PRA 35 on.
3. Activate electronic alignment on the PR 35 by pressing the "Left" arrow button.
4. If the shock warning / slope LEDs blink, the PRA 35 is not receiving the laser beam from the PR 35.
5. If the shock warning / monitoring LEDs blink, realign the PR 35 by moving it counterclockwise.
6. If the slope / monitoring LEDs blink, realign the PR 35 by moving it clockwise.
7. If the monitoring LED blinks, alignment is correct.
8. End electronic alignment mode by pressing the "Right" arrow button.

#### 7.6.5 Setting the slope with the aid of the PRA 76/78 slope adapter

##### NOTE

Check that the slope adapter is fitted correctly between the tripod and the tool (please refer to the operating instructions).

#### 7.7 Monitoring

The monitoring function checks at regular intervals whether the plane that is set (vertical, horizontal or inclined) has been altered inadvertently (e.g. by vibration). If this is the case, the projected plane will be realigned to the zero point (i.e. the marking notch on the PRA 35) (so long as it is still within the receiving area). A PRA 35 is required for use of the monitoring function. An additional laser receiver can be used to detect the laser beam while the laser beam is being monitored.

1. Preparation for activation of the monitoring function is basically the same as the procedure for activation of automatic alignment mode.
2. Position the tool at the desired starting point 1 and switch it on.

3. Position PRA 35 laser receiver at the reference point (point 2) on the axis and secure it there. The PRA 751 can be used to secure it. The tool (point 1) and the PRA 35 (point 2) then form anchor points on the plane. Take care to ensure that the marking notch on the PRA 35 is at exactly the height at which the rotating laser is later to project the laser line or point. The red laser receiving surface on the PRA 35 must face the rotating laser.
4. Take care to ensure there are no obstructions between the rotating laser and the PRA 35 laser receiver which could interfere with communication between the devices. Glass and other translucent materials may also interfere with communication between the devices. Reflections from windows may also cause interference.
5. Switch the PR 35 and the PRA 35 on. The monitoring function can be activated by pressing the "Monitoring mode" button on the PRA 35.
6. The system is then in monitoring mode. The function is indicated in the display on the PRA 35 by two regularly blinking arrows pointing toward the axis in which alignment is to be carried out.
7. The monitoring system checks at regular intervals whether the laser plane has shifted. If it is found to have shifted, the laser plane will be readjusted to the original marking plane as far as possible. If the marking plane is outside the self-levelling range ( $10^\circ (\pm 5^\circ)$ ) or the line of sight between the rotating laser and the laser receiver is blocked for a certain length of time, an error message is displayed.

#### 7.8 Returning to standard mode

In order to return to standard mode, horizontal alignment, 300 /min, the tool must be switched off and restarted.

#### 7.9 Sleep mode

The PR 35 saves power when in sleep mode. The laser is switched off, thereby extending battery life. Activate sleep mode by pressing the "Sleep mode" button on the PRA 35. Deactivate sleep mode by pressing the "Sleep mode" button on the PRA 35 again. After reactivating the PR 35, check the laser settings in order to ensure accuracy.

en

### 7.10 Working with the target plate

The target plate improves laser beam visibility. The target plate should be used in bright conditions or whenever improved laser beam visibility is desired.

Simply bring the target plate into the plane of the projected laser beam. The target plate is made from a material that makes the laser beam more easily visible.

en

## 8. Care and maintenance

### 8.1 Cleaning and drying

1. Blow dust off the lenses.
2. Do not touch the glass with the fingers.
3. Use only a clean, soft cloth for cleaning. If necessary, moisten the cloth slightly with pure alcohol or a little water.  
**NOTE** Abrasive cleaning materials may scratch the glass and impair the accuracy of the laser tool.  
**NOTE** Do not use any other liquids as these may damage the plastic components.
4. Observe the temperature limits when storing your equipment. This is particularly important in winter / summer if the equipment is kept inside a motor vehicle (-30°C to +60°C).

### 8.2 Storage

Remove the tool from its case if it has become wet. The tool, its carrying case and accessories should be cleaned and dried (at maximum 40°C / 104°F). Repack the equipment only once it is completely dry. Check the accuracy of the equipment before it is used after a long period of storage or transportation. Remove the batteries from the tool before storing it for a long period. Leaking batteries may damage the tool. Store the tool in the Hilti toolbox in a dry place.

### 8.3 Transport

Use the Hilti toolbox or packaging of equivalent quality for transporting or shipping your equipment.

#### **CAUTION**

**Always remove the batteries before shipping the tool.**

### 8.4 Hilti Calibration Service

We recommend that the tool is checked by the Hilti Calibration Service at regular intervals in order to verify its reliability in accordance with standards and legal requirements.

Use can be made of the Hilti Calibration Service at any time, but checking at least once a year is recommended.

The Calibration Service provides confirmation that the tool is in conformance, on the day it is tested, with the specifications given in the operating instructions. The tool will be readjusted if deviations from the manufacturer's specification are found. After checking and adjustment, a calibration sticker applied to the tool and a calibration certificate provide written verification that the tool operates in accordance with the manufacturer's specification.

Calibration certificates are always required by companies certified according to ISO 900x.

Your local Hilti Center or representative will be pleased to provide further information.

#### 8.4.1 Checking accuracy

In order to ensure compliance with the technical specifications, the tool should be checked regularly (at least before each major / relevant job).

##### 8.4.1.1 Checking the main and transverse horizontal axes

1. Set up the tripod approx. 20 m from a wall and level the tripod head with a spirit level.
2. Mount the tool on the tripod and use the aiming notch to aim the tool at the wall.
3. Use the receiver to catch the laser beam and mark a point (point 1) on the wall.
4. Pivot the tool clockwise through 90° about its own axis. In doing so, ensure that the height of the tool does not change.
5. Use the laser receiver to catch the laser beam and mark a second point (point 2) on the wall.

- Repeat steps 4 and 5 twice and mark points 3 and 4 on the wall with the aid of the laser receiver.  
When this procedure is carried out carefully, the vertical distance between the two marked points 1 and 3 (main axis) or, respectively, points 2 and 4 (transverse axis) should be less than 3 mm (at 20 m). If the deviation is greater than this, the tool should be returned to a Hilti Service Center for calibration.

#### 8.4.1.2 Checking the vertical axis 16 17





- Place the tool in the vertical position on a flat floor approx. 20 m from a wall.
- Adjust the position of the tool so that the grips are parallel to the wall.

- Switch the tool on and mark the reference point (R) on the floor.
- With the aid of the receiver, mark point (A) at the base of the wall (set the rotating laser to medium speed).
- With the aid of the receiver, mark point (B) at a height of approx. 10 m.
- Pivot the tool through 180° and realign it with the reference point (R) on the floor and with point (A) at the base of the wall.
- With the aid of the receiver, mark point (C) at a height of approx. 10 m.



**NOTE** When the procedure has been carried out carefully, the horizontal distance between the two points (B) and (C) marked at a height of 10 meters should be less than 1.5 mm (at 10 m). If the deviation is greater: Please return the tool to a Hilti Service Center for calibration.

en

## 9. Troubleshooting

Fault	Possible cause	Remedy
The display shows this symbol 	The button lock is active.	Deactivate the button lock.
The display shows this symbol 	The PRA 35 has not been paired with the PR 35.	Pair the tools (see section 6.9)
The display shows this symbol 	Invalid entry; the command is not possible.	Press a valid button.
The display shows this symbol 	The command is valid but the tool doesn't react.	Switch on all tools and make sure they are within wireless communication range.
The display shows this symbol 	No communication between the PR 35 and PRA 35.	Check to ensure that there are no obstacles between the tools and that the maximum wireless communication range is not exceeded. For good wireless communication, the PR 35 should be placed $\geq 10$ cm (4 in) above floor level.

en

Fault	Possible cause	Remedy
The display shows this symbol 	The tool is in sleep mode (the tool will remain in sleep mode for max. 4 hours).	Activate the tool by pressing the "Sleep" button. Activate the tool settings after activating the tool.
The display shows this symbol 	Fault.	Contact Hilti Service.

## 10. Disposal

### WARNING

Improper disposal of the equipment may have serious consequences:

The burning of plastic components generates toxic fumes which may present a health hazard.

Batteries may explode if damaged or exposed to very high temperatures, causing poisoning, burns, acid burns or environmental pollution.

Careless disposal may permit unauthorized and improper use of the equipment. This may result in serious personal injury, injury to third parties and pollution of the environment.



Most of the materials from which Hilti tools or appliances are manufactured can be recycled. The materials must be correctly separated before they can be recycled. In many countries, Hilti has already made arrangements for taking back old tools and appliances for recycling. Ask Hilti customer service or your Hilti representative for further information.



For EC countries only

Disposal of electric tools together with household waste is not permissible.

In observance of European Directive 2002/96/EC on waste electrical and electronic equipment and its implementation in accordance with national law, electric tools that have reached the end of their life must be collected separately and returned to an environmentally compatible recycling facility.



Dispose of the batteries in accordance with national regulations.



## 11. Manufacturer's warranty - tools

Hilti warrants that the tool supplied is free of defects in material and workmanship. This warranty is valid so long as the tool is operated and handled correctly, cleaned and serviced properly and in accordance with the Hilti Operating Instructions, and the technical system is maintained. This means that only original Hilti consumables, components and spare parts may be used in the tool.

This warranty provides the free-of-charge repair or replacement of defective parts only over the entire lifespan of the tool. Parts requiring repair or replacement as a result of normal wear and tear are not covered by this warranty.

**Additional claims are excluded, unless stringent national rules prohibit such exclusion. In particular, Hilti is not obligated for direct, indirect, incidental or consequential damages, losses or expenses in connection with, or by reason of, the use of, or inability to use the tool for any purpose. Implied warranties of merchantability or fitness for a particular purpose are specifically excluded.**

For repair or replacement, send the tool or related parts immediately upon discovery of the defect to the address of the local Hilti marketing organization provided.

This constitutes Hilti's entire obligation with regard to warranty and supersedes all prior or contemporaneous comments and oral or written agreements concerning warranties.

en

## 12. EC declaration of conformity

Designation:	Rotating laser
Type:	PR 35
Year of design:	2010

We declare, on our sole responsibility, that this product complies with the following directives and standards: EN 300 440-2, EN 301 489-3 V1.4.1, EN 60950-1, EN 55014-1, EN 55014-2, EN 61000-3-2, EN 61000-3-3, 2004/108/EC, 2006/42/EC.

### Hilti Corporation



**Dietmar Sartor**  
Head of BA Quality and Process  
Management  
Business Area Electric Tools & Ac-  
cessories  
04 2010



**Tassilo Deinzer**  
Head BU Measuring Systems

BU Measuring Systems

04 2010