

Certification Test Report

FCC ID: SDBZIGMOD10
IC: 2220A-ZIGMOD10

FCC Rule Part: 15.247
IC Radio Standards Specification: RSS-210

ACS Report Number: 10-0020.W06.11.A

Manufacturer: Sensus Metering Systems, Inc.
Model: ZIGMOD10

Test Begin Date: July 15, 2009
Test End Date: January 24, 2010

Report Issue Date: August 26, 2010



FOR THE SCOPE OF ACCREDITATION UNDER LAB Code 200612-0

This report must not be used by the client to claim product certification, approval, or endorsement by NVLAP, NIST, or any agency of the Federal Government.

Reviewed by:

A handwritten signature in black ink, appearing to read 'Kirby Munroe', is written over a horizontal line.

Kirby Munroe
Director, Wireless Certifications
ACS, Inc.

This test report shall not be reproduced except in full. This report may be reproduced in part with prior written consent of ACS, Inc. The results contained in this report are representative of the sample(s) submitted for evaluation.

This report contains 30 pages

TABLE OF CONTENTS

1	GENERAL	3
1.1	PURPOSE.....	3
1.2	PRODUCT DESCRIPTION	3
1.2.1	<i>General</i>	3
1.3	TEST METHODOLOGY AND CONSIDERATIONS	3
2	TEST FACILITIES	4
2.1	LOCATION	4
2.2	LABORATORY ACCREDITATIONS/RECOGNITIONS/CERTIFICATIONS	4
2.3	RADIATED EMISSIONS TEST SITE DESCRIPTION	5
2.3.1	<i>Semi-Anechoic Chamber Test Site</i>	5
2.3.2	<i>Open Area Tests Site (OATS)</i>	6
2.4	CONDUCTED EMISSIONS TEST SITE DESCRIPTION	7
3	APPLICABLE STANDARD REFERENCES	7
4	LIST OF TEST EQUIPMENT	8
5	SUPPORT EQUIPMENT	9
6	EQUIPMENT UNDER TEST SETUP BLOCK DIAGRAM	9
7	SUMMARY OF TESTS	10
7.1	ANTENNA REQUIREMENT – FCC: SECTION 15.203	10
7.2	POWER LINE CONDUCTED EMISSIONS – FCC: SECTION 15.207 IC: RSS-GEN 7.2.2.....	10
7.2.1	<i>Measurement Procedure</i>	10
7.2.2	<i>Measurement Results</i>	10
7.3	RADIATED EMISSIONS – FCC: SECTION 15.109(UNINTENTIONAL RADIATION) IC: RSS-210 2.6..	12
7.3.1	<i>Measurement Procedure</i>	12
7.3.2	<i>Measurement Results</i>	12
	TABLE 7.3-1: RADIATED EMISSIONS TABULATED DATA	12
7.4	6dB / 99% BANDWIDTH – FCC: SECTION 15.247(A)(2) IC: RSS-210 A8.2(A)	13
7.4.1	<i>Measurement Procedure</i>	13
7.4.2	<i>Measurement Results</i>	13
7.5	PEAK OUTPUT POWER REQUIREMENT - FCC SECTION 15.247(B)(3) IC: RSS-210 A8.4(4)	17
7.5.1	<i>Measurement Procedure</i>	17
7.5.2	<i>Measurement Results</i>	17
7.6	BAND-EDGE COMPLIANCE AND SPURIOUS EMISSIONS-FCC 15.247D IC:RSS-210 2.6, A8.5	19
7.6.1	<i>Band-Edge Compliance of RF Conducted Emissions</i>	19
7.6.1.1	<i>Measurement Procedure</i>	19
7.6.1.2	<i>Measurement Results</i>	19
7.6.2	<i>RF Conducted Spurious Emissions</i>	21
7.6.2.1	<i>Measurement Procedure</i>	21
7.6.2.2	<i>Measurement Results</i>	21
7.6.3	<i>Radiated Spurious Emissions (Restricted Bands) - FCC Sec. 15.205 IC: RSS-210 2.6</i>	26
7.6.3.1	<i>Measurement Procedure</i>	26
7.6.3.2	<i>Duty Cycle Correction</i>	26
7.6.3.3	<i>Measurement Results</i>	26
7.6.3.4	<i>Sample Calculation:</i>	27
7.7	PEAK POWER SPECTRAL DENSITY- FCC SECTION 15.247(E) IC: RSS-210 A8.2(B).....	28
7.7.1	<i>Measurement Procedure</i>	28
7.7.2	<i>Measurement Results</i>	28
8	CONCLUSION	30

1 GENERAL

1.1 Purpose

The purpose of this report is to demonstrate compliance with Part 15 Subpart C of the FCC's Code of Federal Regulations and Industry Canada's Radio Standards Specification RSS-210 for a single modular approval.

1.2 Product description

1.2.1 General

The Sensus ZigBee Module ZIGMOD10 is a self contained Modular Transmitter. This module is designed to interface between the Electric Meter and the Home Area Network (HAN) and will reside within the Electric Meter.

Manufacturer Information:
Sensus Metering Systems, Inc.
400 Perimeter Park Drive, Suite K
Morrisville, NC 27560

Test Sample Serial Number(s): Conducted: 00000178; Radiated: 00000167

Test Sample Condition: The test samples were provided in good working order with no visible defects.

1.3 Test Methodology and Considerations

For radiated emissions, including band edge, multiple orientations of the EUT were evaluated. Data representing the worst case orientation is provided in this report. AC power line conducted emissions testing was performed with the module installed in a representative host device.

For the purpose of RF conducted measurements, the module was modified with a temporary 50 ohm antenna port.

The EUT can be collocated with Sensus Metering Systems module model IDTB002 FCC ID: SDBIDTB002, IC: 2220A-IDTB002 when integrated in electric utility meters. Radiated inter-modulation testing was performed with both modules simultaneously transmitting when integrated in utility meters type 1S, 2S, and 12S. All spurious emission levels were below the specified limit.

2 TEST FACILITIES

2.1 Location

The radiated and conducted emissions test sites are located at the following address:

Advanced Compliance Solutions
5015 B.U. Bowman Drive
Buford, GA 30518
Phone: (770) 831-8048
Fax: (770) 831-8598

2.2 Laboratory Accreditations/Recognitions/Certifications

ACS is accredited to ISO/IEC 17025 by the National Institute of Standards and Technology under their National Voluntary Laboratory Accreditation Program (NVLAP), Lab Code 200612-0. Unless otherwise specified, all tests methods described within this report are covered under the ISO/IEC 17025 scope of accreditation.

The Semi-Anechoic Chamber Test Site, Open Area Test Site (OATS) and Conducted Emissions Site have been fully described, submitted to, and accepted by the FCC, Industry Canada and the Japanese Voluntary Control Council for Interference by information technology equipment.

FCC Registration Number: 894540

Industry Canada Lab Code: IC 4175A-1

VCCI Member Number: 1831

- VCCI OATS Registration Number R-1526
- VCCI Conducted Emissions Site Registration Number: C-1608

2.3 Radiated Emissions Test Site Description

2.3.1 Semi-Anechoic Chamber Test Site

The Semi-Anechoic Chamber Test Site consists of a 20' x 30' x 18' shielded enclosure. The chamber is lined with Toyo Ferrite Grid Absorber, model number FFG-1000. The ferrite tile grid is 101 x 101 x 19mm thick and weighs approximately 550 grams. These tiles are mounted on steel panels and installed directly on the inner walls of the chamber.

The turntable is 150cm in diameter and is located 160cm from the back wall of the chamber. The chamber is grounded via 1 - 8' copper ground rod, installed at the center of the back wall, it is bound to the ground plane using 3/4" stainless steel braided cable.

The turntable is all steel, flush mounted table installed in an all steel frame. The table is remotely operated from inside the control room located 25' from the range. The turntable is electrically bonded to the surrounding ground plane via steel fingers installed on the edge of the turn table. The steel fingers make constant contact with the ground plane during operation.

Behind the turntable is a 3' x 6' x 4' deep shielded pit used for support equipment if necessary. The pit is equipped with 1 - 4" PVC chases from the turntable to the pit that allow for cabling to the EUT if necessary. The underside of the turntable can be accessed from the pit so cables can be supplied to the EUT from the pit.

A diagram of the Semi-Anechoic Chamber Test Site is shown in Figure 2.3-1 below:

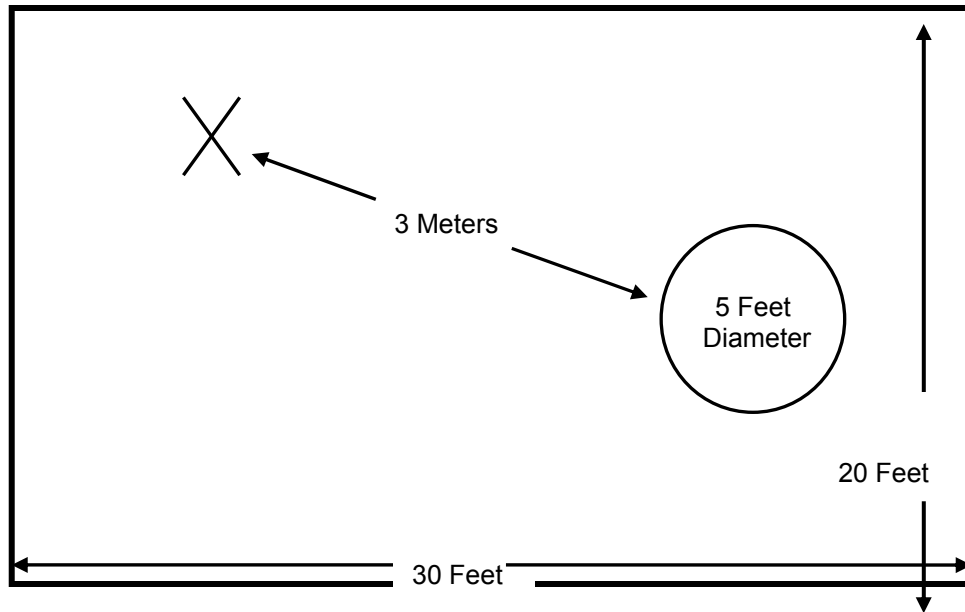

Figure 2.3-1: Semi-Anechoic Chamber Test Site

2.3.2 Open Area Tests Site (OATS)

The open area test site consists of a 40' x 66' concrete pad covered with a perforated electro-plated galvanized sheet metal. The perforations in the sheet metal are 1/8" holes that are staggered every 3/16". The individual sheets are placed to overlap each other by 1/4" and are riveted together to provide a continuous seam. Rivets are spaced every 3" in a 3 x 20 meter perimeter around the antenna mast and EUT area. Rivets in the remaining area are spaced as necessary to properly secure the ground plane and maintain the electrical continuity.

The entire ground plane extends 12' beyond the turntable edge and 16' beyond the antenna mast when set to a 10 meter measurement distance. The ground plane is grounded via 4 - 8' copper ground rods, each installed at a corner of the ground plane and bound to the ground plane using 3/4" stainless steel braided cable.

The turntable is an all aluminum 10' flush mounted table installed in an all aluminum frame. The table is remotely operated from inside the control room located 40' from the range. The turntable is electrically bonded to the surrounding ground plane via steel fingers installed on the edge of the turn table. The steel fingers make constant contact with the ground plane during operation.

Adjacent to the turntable is a 7' x 7' square and 4' deep concrete pit used for support equipment if necessary. The pit is equipped with 5 - 4" PVC chases from the pit to the control room that allow for cabling to the EUT if necessary. The underside of the turntable can be accessed from the pit so cables can be supplied to the EUT from the pit. The pit is covered with 2 sheets of 1/4" diamond style re-enforced steel sheets. The sheets are painted to match the perforated steel ground plane; however the underside edges have been masked off to maintain the electrical continuity of the ground plane. All reflecting objects are located outside of the ellipse defined in ANSI C63.4.

A diagram of the Open Area Test Site is shown in Figure 2.3-2 below:

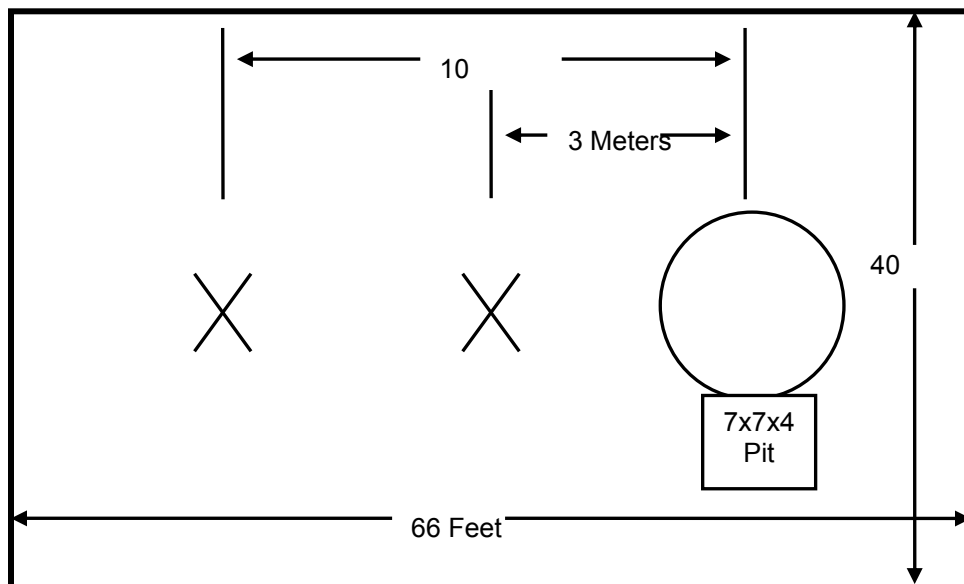

Figure 2.3-2: Open Area Test Site

2.4 Conducted Emissions Test Site Description

The AC mains conducted EMI site is located in the main EMC lab. It consists of an 8' x 8' solid aluminum horizontal ground reference plane (GRP) bonded every 3" to an 8' X 8' vertical ground plane.

The site is of sufficient size to test table top and floor standing equipment in accordance with section 6.1.4 of ANSI C63.4.

A diagram of the room is shown below in figure 4.1.3-1:

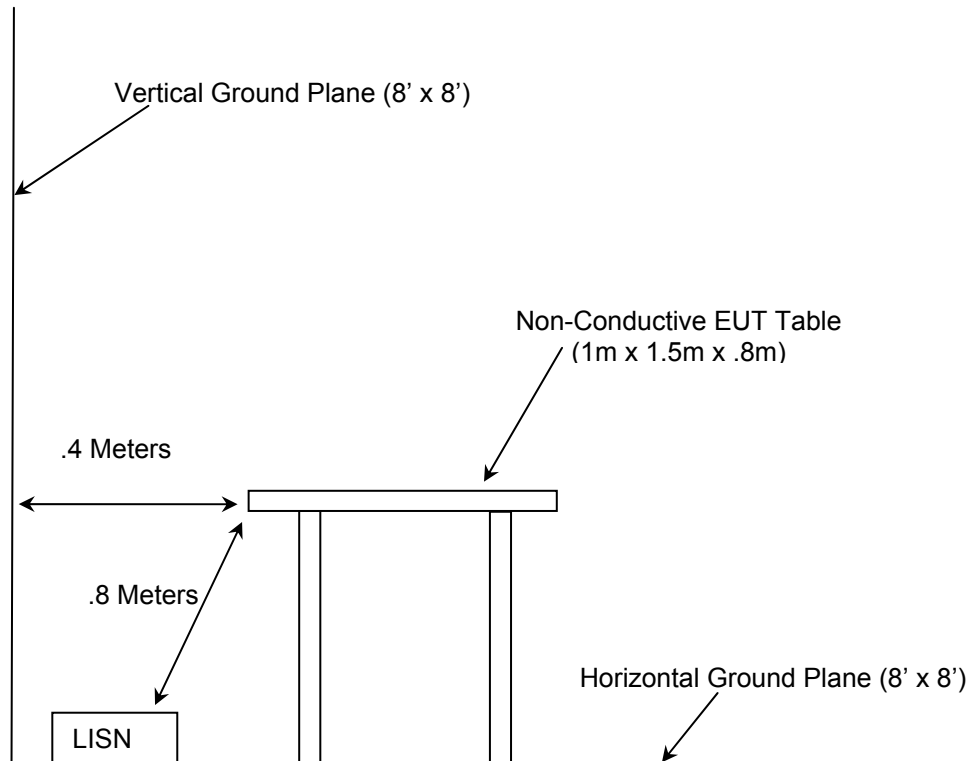

Figure 2.4-1: AC Mains Conducted EMI Site

3 APPLICABLE STANDARD REFERENCES

The following standards were used:

- ❖ ANSI C63.4-2003: Method of Measurements of Radio-Noise Emissions from Low-Voltage Electrical and Electronic Equipment in the 9KHz to 40GHz
- ❖ US Code of Federal Regulations (CFR): Title 47, Part 2, Subpart J: Equipment Authorization Procedures, 2010
- ❖ US Code of Federal Regulations (CFR): Title 47, Part 15, Subpart C: Radio Frequency Devices, Intentional Radiators, 2010
- ❖ FCC KDB Publication No. 558074 - Guidance on Measurements for Digital Transmission Systems (47 CFR 15.247), March 2005
- ❖ Industry Canada Radio Standards Specification: RSS-210 - Low-power License-exempt Radiocommunication Devices (All Frequency Bands): Category I Equipment, Issue 7 June 2007
- ❖ Industry Canada Radio Standards Specification: RSS-GEN – General Requirements and Information for the Certification of Radiocommunication Equipment, Issue2, June 2007.

4 LIST OF TEST EQUIPMENT

The calibration interval of test equipment is annually or the manufacturer's recommendations. Where the calibration interval deviates from the annual cycle based on the instrument manufacturer's recommendations, it shall be stated below.

Table 4-1: Test Equipment

Equipment Calibration Information					
ACS#	Mfg.	Eq. type	Model	S/N	Cal. Due
1	Rohde & Schwarz	Spectrum Analyzers	ESMI - Display	833771/007	09-21-2010
2	Rohde & Schwarz	Spectrum Analyzers	ESMI-Receiver	839587/003	09-21-2010
3	Rohde & Schwarz	Spectrum Analyzers	ESMI - Display	839379/011	02-02-2010
4	Rohde & Schwarz	Spectrum Analyzers	ESMI-Receiver	833827/003	02-02-2010
25	Chase	Antennas	CBL6111	1043	09-02-2010
30	Spectrum Technologies	Antennas	DRH-0118	970102	05-08-2010
73	Agilent	Amplifiers	8447D	2727A05624	07-15-2010
153	EMCO	LISN	3825/2	9411-2268	01-27-2010
167	ACS	Cable Set	Chamber EMI Cable Set	167	02-06-2010 (See Note1)
168	Hewlett Packard	Attenuators	11947A	44829	02-10-2010 (See Note2)
283	Rohde & Schwarz	Spectrum Analyzers	FSP40	1000033	09-21-2010
291	Florida RF Cables	Cables	SMRE-200W-12.0-SMRE	None	11-24-2010 (See Note1)
292	Florida RF Cables	Cables	SMR-290AW-480.0-SMR	None	11-24-2010 (See Note1)
321	Hewlett Packard	Amplifiers	HPC 8447D	1937A02809	10-06-2010
324	ACS	Cables	Belden	8214	07-15-2010
329	A.H.Systems	Antennas	SAS-571	721	08-04-2010
338	Hewlett Packard	Amplifiers	8449B	3008A01111	10-16-2010
339	Aeroflex/Weinschel	Attenuators	AS-18	7142	07-02-2010 (See Note2)
422	Florida RF	Cables	SMS-200AW-72.0-SMR	0805	02-05-2010 (See Note2)
432	Microwave Circuits	Filter	H3G020G4	264066	07-17-2010

Note1: Items characterized on an annual cycle. The date shown indicates the next characterization due date.

Note2: Items verified on an annual cycle. The date shown indicates the next verification due date.

5 SUPPORT EQUIPMENT

Table 5-1: Support Equipment

Item	Equipment Type	Manufacturer	Model Number	Serial Number
1	EUT	Sensus Metering Systems, Inc.	ZIGMOD10	00000167
2	Electric Meter	Sensus Metering Systems, Inc.	CL200 FM2S	00 001 971 (ENG006)
3	Power Supply	OK Industries	PS732	36095

6 EQUIPMENT UNDER TEST SETUP BLOCK DIAGRAM

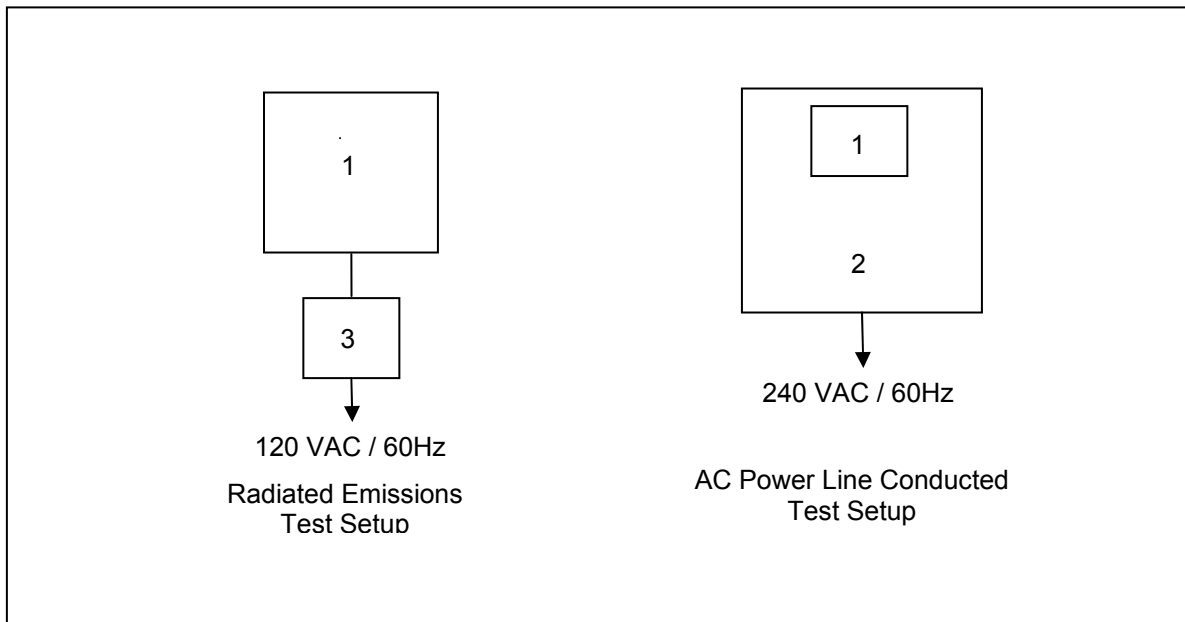

Note: For RF conducted measurements, EUT SN 00000176 was used and connected directly to the RF input of a spectrum analyzer.

7 SUMMARY OF TESTS

Along with the tabular data shown below, plots were taken of all signals deemed important enough to document.

7.1 Antenna Requirement – FCC: Section 15.203

The antenna is an inverted F PCB trace antenna with a measured gain of 0 dBi

7.2 Power Line Conducted Emissions – FCC: Section 15.207 IC: RSS-Gen 7.2.2

7.2.1 Measurement Procedure

ANSI C63.4 sections 6 and 7 were the guiding documents for this evaluation. Conducted emissions were performed from 150kHz to 30MHz with the spectrum analyzer's resolution bandwidth set to 9kHz and the video bandwidth set to 30kHz. The calculation for the conducted emissions is as follows:

Corrected Reading = Analyzer Reading + LISN Loss + Cable Loss

Margin = Applicable Limit - Corrected Reading

7.2.2 Measurement Results

Results of the test are shown below in and Table 7.2.2-1.

Table 7.2.2-1: Line 1 Conducted EMI Results

Frequency (MHz)	Detector	Level (dBuV)	Correction Factor (dB)	Limit (dBuV)	Margin (dB)
0.204000	QP	50.2	9.9	63	13.2
0.408000	QP	46.6	10.1	58	11.1
0.510000	QP	44.1	10.0	56	12.0
0.606000	QP	42.4	10.0	56	13.6
0.714000	QP	44.7	10.1	56	11.3
0.972000	QP	28.6	10.0	56	27.4
1.086000	QP	26.8	10.0	56	29.2
1.362000	QP	24.1	10.0	56	31.9
10.740000	QP	30	9.9	60	30.0
14.322000	QP	25.3	9.8	60	34.7
0.288000	AV	23.7	10.0	51	26.9
0.456000	AV	21.3	10.0	47	25.5
0.528000	AV	21.2	10.0	46	24.8
0.636000	AV	20.7	10.0	46	25.3
0.708000	AV	19.9	10.1	46	26.1
0.960000	AV	13.1	10.0	46	32.9
1.086000	AV	11.7	10.0	46	34.3
1.380000	AV	10.6	10.0	46	35.4
10.650000	AV	7	9.9	50	43.0
14.238000	AV	7	9.8	50	43.0

Table 7.2.2-2: Line 2 Conducted EMI Results

Frequency (MHz)	Detector	Level (dBuV)	Correction Factor (dB)	Limit (dBuV)	Margin (dB)
0.204000	QP	51.3	9.9	63	12.1
0.264000	QP	44.9	10.0	61	16.4
0.312000	QP	47.9	10.0	60	12.0
0.492000	QP	41.3	10.0	56	14.9
0.702000	QP	41.3	10.1	56	14.7
0.708000	QP	44.1	10.1	56	11.9
0.828000	QP	36.3	10.0	56	19.7
0.846000	QP	35.7	10.0	56	20.3
0.966000	QP	29.6	10.0	56	26.5
1.104000	QP	27.4	10.0	56	28.6
0.222000	AV	26.2	9.9	53	26.6
0.294000	AV	23.9	10.0	50	26.5
0.330000	AV	22.8	10.0	50	26.6
0.486000	AV	21.8	10.0	46	24.4
0.756000	AV	19.3	10.1	46	26.7
0.774000	AV	18.9	10.1	46	27.1
0.876000	AV	16	10.0	46	30.0
1.038000	AV	12	10.0	46	34.0
1.050000	AV	12	10.0	46	34.0

7.3 Radiated Emissions – FCC: Section 15.109(Unintentional Radiation) IC: RSS-210 2.6

7.3.1 Measurement Procedure

Radiated emissions tests were performed over the frequency range of 30MHz to 12.5GHz. Measurements of the radiated field strength were made at a distance of 3m from the boundary of the equipment under test (EUT) and the receiving antenna. The antenna height was varied from 1m to 4m so that the maximum radiated emissions level would be detected. Radiated measurements above 30MHz and below 1GHz were made with the Spectrum Analyzer's resolution bandwidth set to 120 KHz using a Quasi-peak detector. Above 1GHz, peak and average measurements are taken with the RBW and VBW were set to 1MHz.

7.3.2 Measurement Results

Results of the test are given in Table 7.3.2-1:

Table 7.3-1: Radiated Emissions Tabulated Data

Frequency (MHz)	Level (dBuV)		Antenna Polarity (H/V)	Correction Factors (dB)	Corrected Level (dBuV/m)		Limit (dBuV/m)		Margin (dB)	
	pk	Qpk/Avg			pk	Qpk/Avg	pk	Qpk/Avg	pk	Qpk/Avg
76.799	-----	39.18	V	-19.38	-----	19.80	-----	40.0	-----	20.20
87.683	-----	36.61	V	-16.64	-----	19.97	-----	40.0	-----	20.03
201.161	-----	33.26	H	-14.42	-----	18.84	-----	43.5	-----	24.66
383.962	-----	33.16	H	-8.36	-----	24.80	-----	46.0	-----	21.20
415.959	-----	30.54	H	-7.44	-----	23.10	-----	46.0	-----	22.90
447.962	-----	36.76	V	-7.30	-----	29.46	-----	46.0	-----	16.54
511.948	-----	31.71	V	-5.48	-----	26.23	-----	46.0	-----	19.77

* Note: All emissions above 511.948 MHz were attenuated below the permissible limit.

7.4 6dB / 99% Bandwidth – FCC: Section 15.247(a)(2) IC: RSS-210 A8.2(a)

7.4.1 Measurement Procedure

The 6dB bandwidth was measured in accordance with the FCC KDB Publication No. 558074 “Guidance on Measurements for Digital Transmission Systems (47 CFR 15.247)”. The RBW of the spectrum analyzer was set to 100 kHz and VBW 300 kHz. Span was set large enough to capture the entire emissions and >> RBW.

The 99% occupied bandwidth was measured with the spectrum analyzer span set to 2 to 3 times the estimated bandwidth of the emission. The RBW was to ≥ 1% of the estimated emission bandwidth. The trace was set to max hold with a peak detector active. The occupied bandwidth measurement function of the analyzer was used for the 99% bandwidth.

7.4.2 Measurement Results

Results are shown below in table 7.4.2-1 and figure 7.4.2-1 to 7.4.2-6:

Table 7.4.2-1: 6dB / 99% Bandwidth

Frequency [MHz]	6dB Bandwidth [MHz]	99% Bandwidth [MHz]
2405	1.63	2.78
2440	1.63	2.75
2480	1.65	2.80

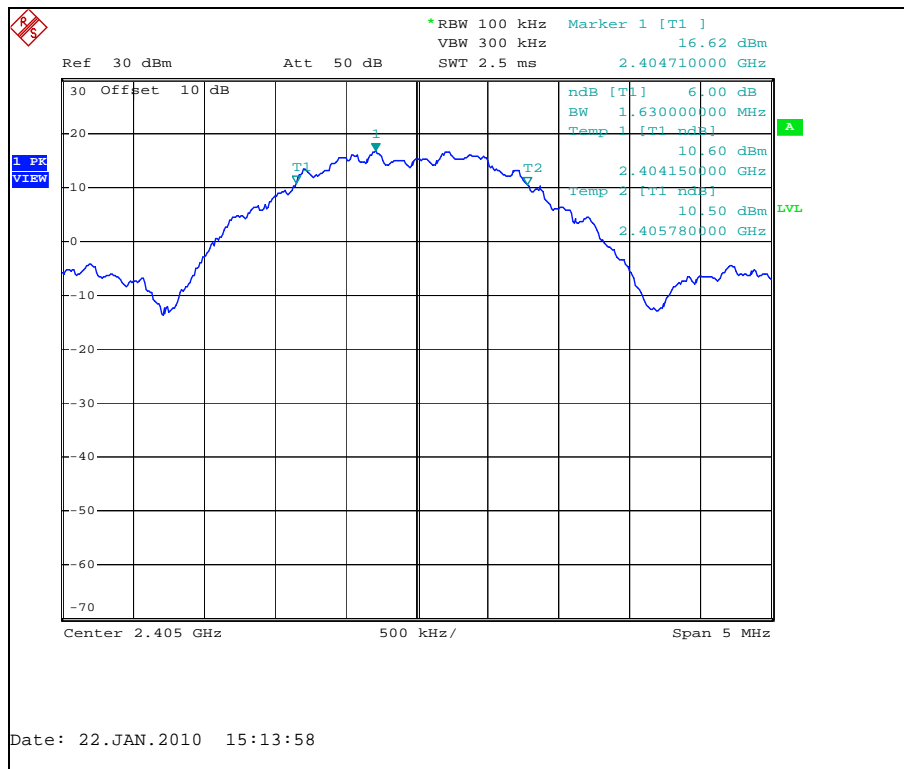

Figure 7.4.2-1: 6dB Bandwidth Plot – Low Channel

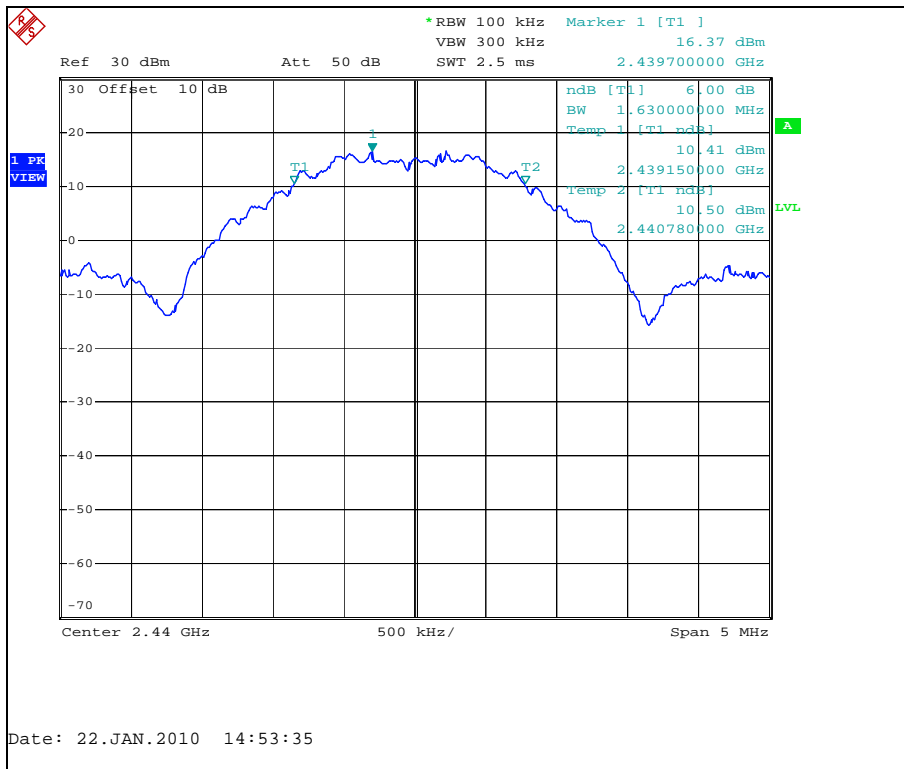

Figure 7.4.2-2: 6dB Bandwidth Plot – Mid Channel

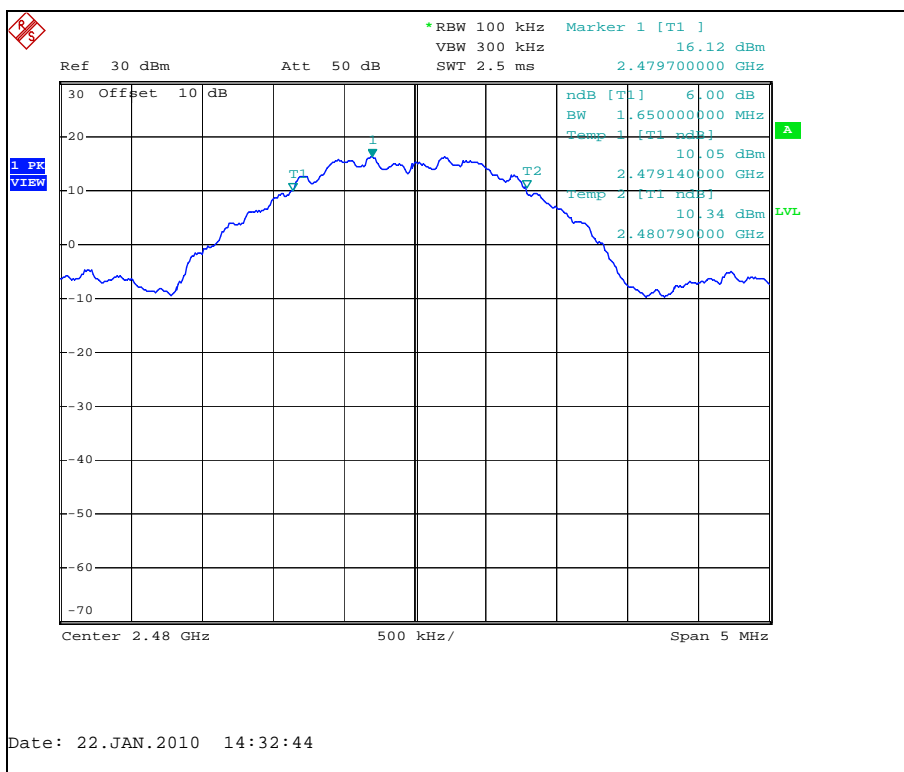

Figure 7.4.2-3: 6dB Bandwidth Plot – High Channel



Figure 7.4.2-4: 99% Bandwidth Plot – Low Channel

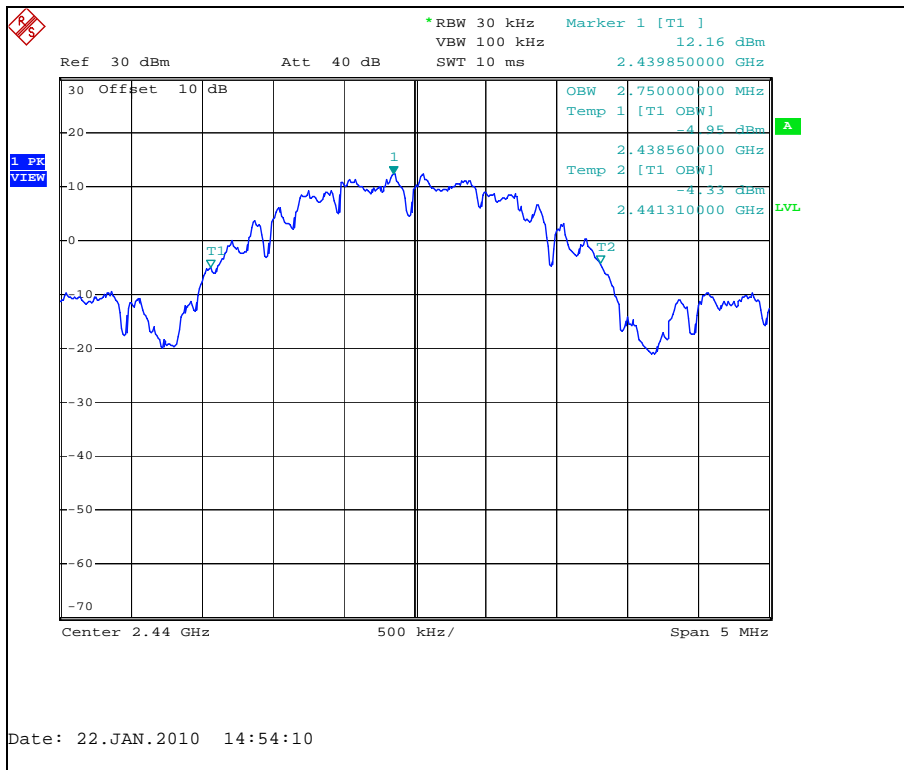

Figure 7.4.2-5: 99% Bandwidth Plot – Mid Channel

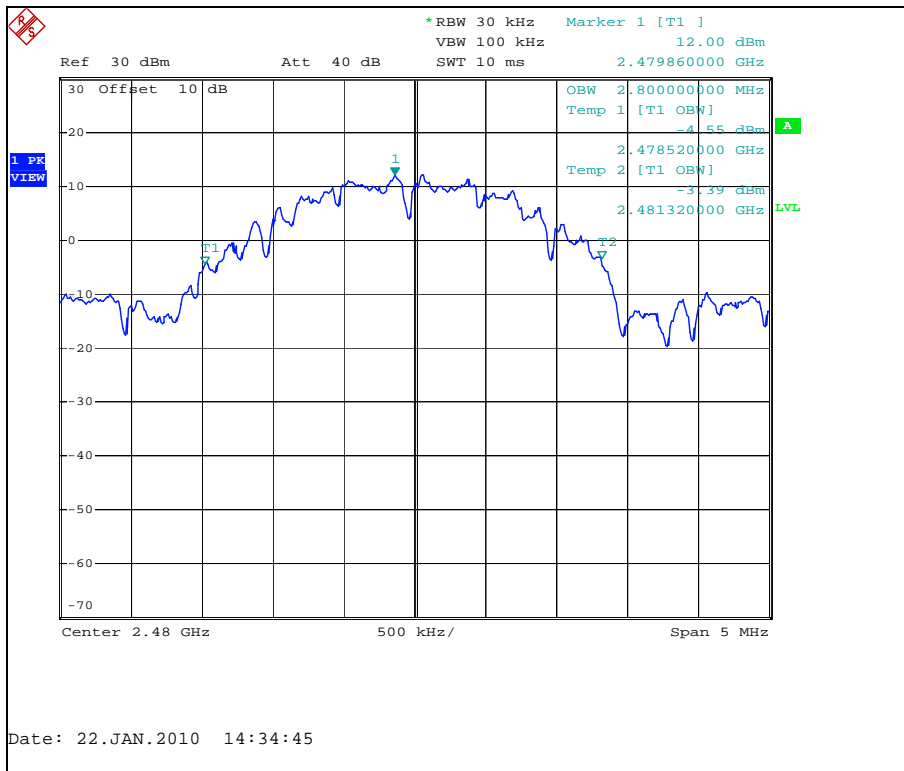

Figure 7.4.2-6: 99% Bandwidth Plot – High Channel

7.5 Peak Output Power Requirement - FCC Section 15.247(b)(3) IC: RSS-210 A8.4(4)

7.5.1 Measurement Procedure

The Peak Output Power was measured in accordance with the FCC KDB Publication No. 558074 "Guidance on Measurements for Digital Transmission Systems (47 CFR 15.247)" Power Option 1. The RF output of the equipment under test was directly connected to the input of the Spectrum Analyzer.

Data was collected with the EUT operating at maximum power per channelization.

7.5.2 Measurement Results

Results are shown below in Table 7.5.2-1 and Figures 7.5.2-1 to 7.5.2-3.

Table 7.5.2-1: Peak Output Power

Frequency (MHz)	Output Power (dBm)
2405	20.76
2440	20.37
2480	20.03

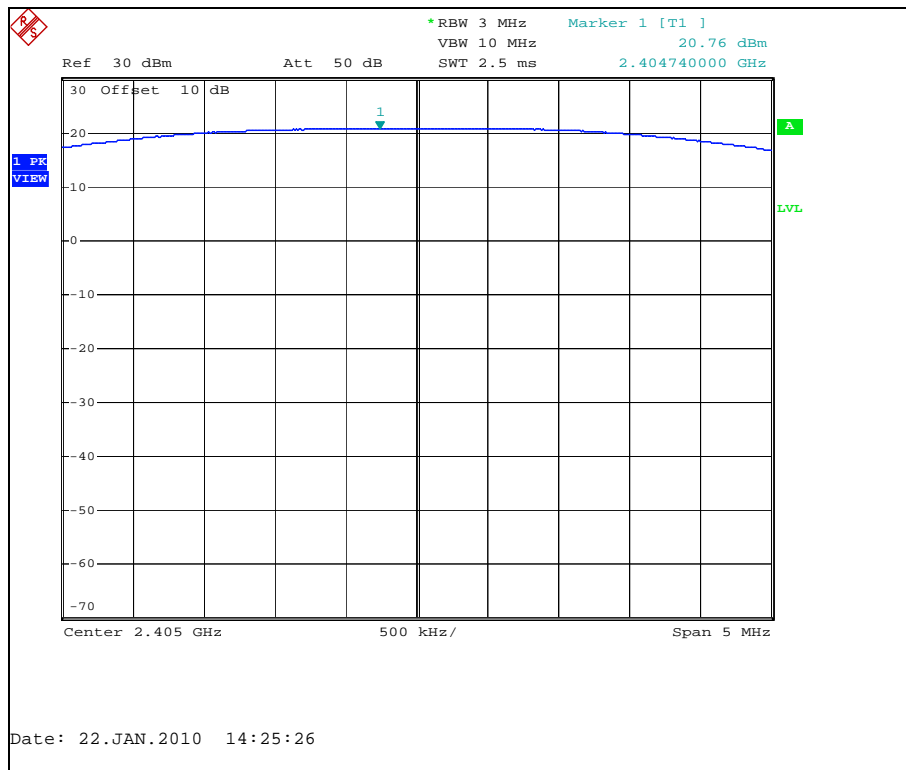

Figure 7.5.2-1: Output power – Low Channel

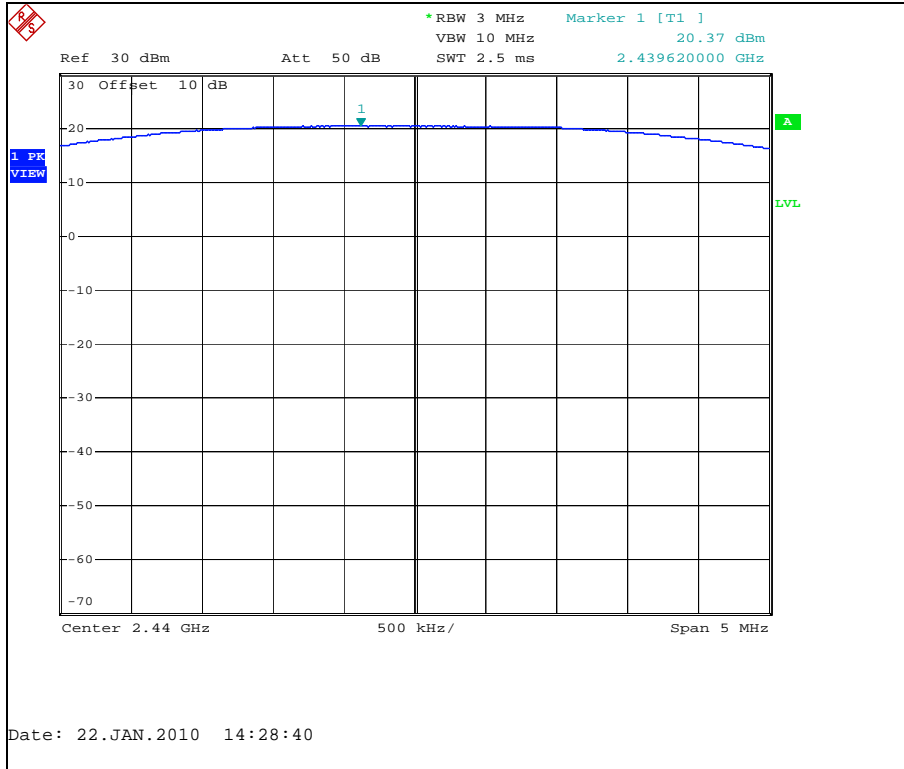

Figure 7.5.2-2: Output power – Mid Channel

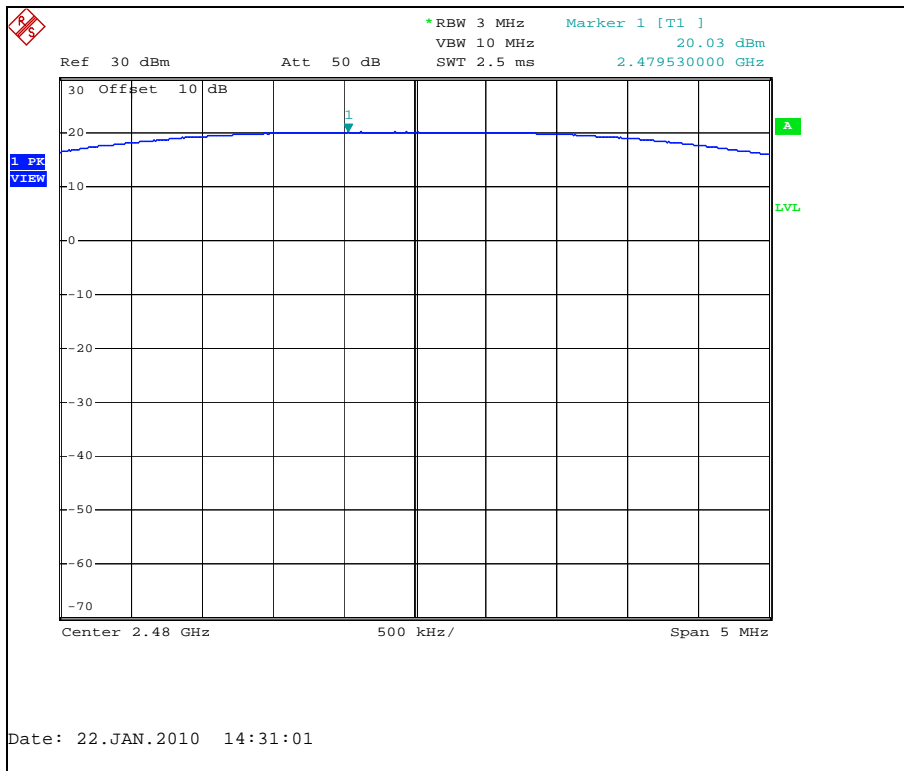

Figure 7.5.2-3: Output power – High Channel

7.6 Band-Edge Compliance and Spurious Emissions-FCC 15.247d IC:RSS-210 2.6, A8.5

7.6.1 Band-Edge Compliance of RF Conducted Emissions

7.6.1.1 Measurement Procedure

The EUT was investigated at the low and high channels of operation to determine band-edge compliance. All antenna types were evaluated. Because the upper band-edge coincides with a restricted band, band-edge compliance for the upper band-edge was determined using the radiated mark-delta method. The radiated field strength of the fundamental emission was first determined and then the mark-delta method was used to determine the field strength of the band-edge emissions.

The lower band-edge compliance was determined using the marker-delta method in which the radio frequency power that is produced by the EUT is at least 20 dB below that in the 100 kHz bandwidth within the band that contains the highest level of desired power.

7.6.1.2 Measurement Results

Band-edge compliance is displayed in Table 7.6.1.2-1 and Figures 7.6.1.2-1 – 7.6.1.2-3.

Table 7.6.1.2-1: Upper Band-edge Marker Delta Method

Frequency (MHz)	Level (dBuV)		Antenna Polarity (H/V)	Correction Factors (dB)	Fundamental Field Strength (dBuV/m)		Delta-Marker (dB)	Band-edge Field Strength (dBuV/m)		Margin to Limit (dBuV/m)	
	pk	avg			pk	avg		pk	avg	74	54
Fundamental Frequency											
2480	117.81	115.28	H	-4.19	113.62	85.07	42.84	70.78	50.40	3.22	3.60
2480	119.49	117.05	V	-4.19	115.30	86.84	42.69	72.61	52.32	1.39	1.68

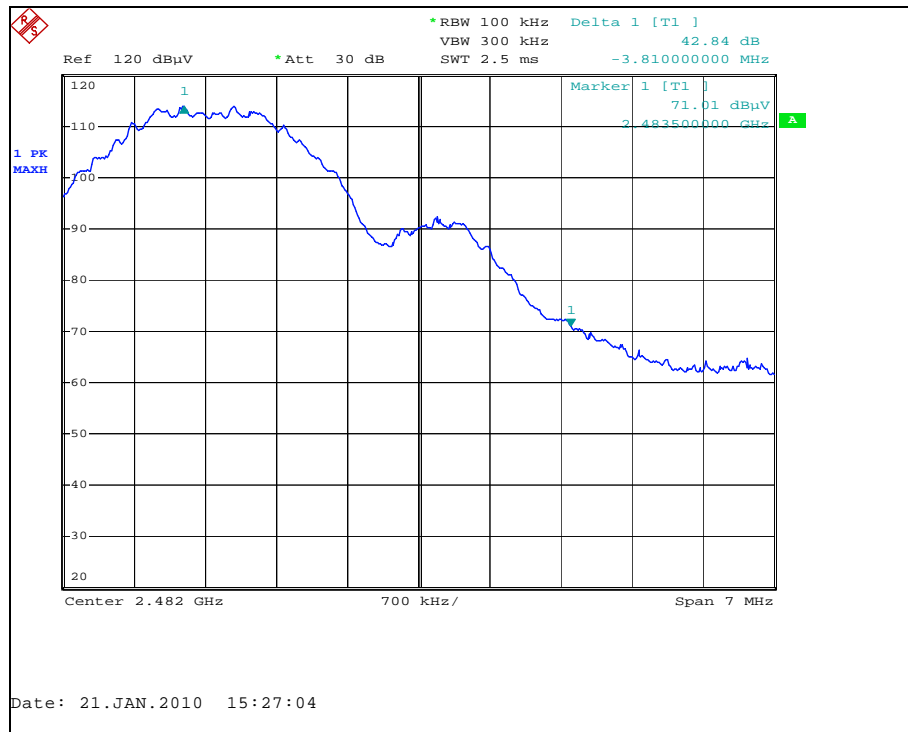

Figure 7.6.1.2-1: Upper Band-edge – Hpol

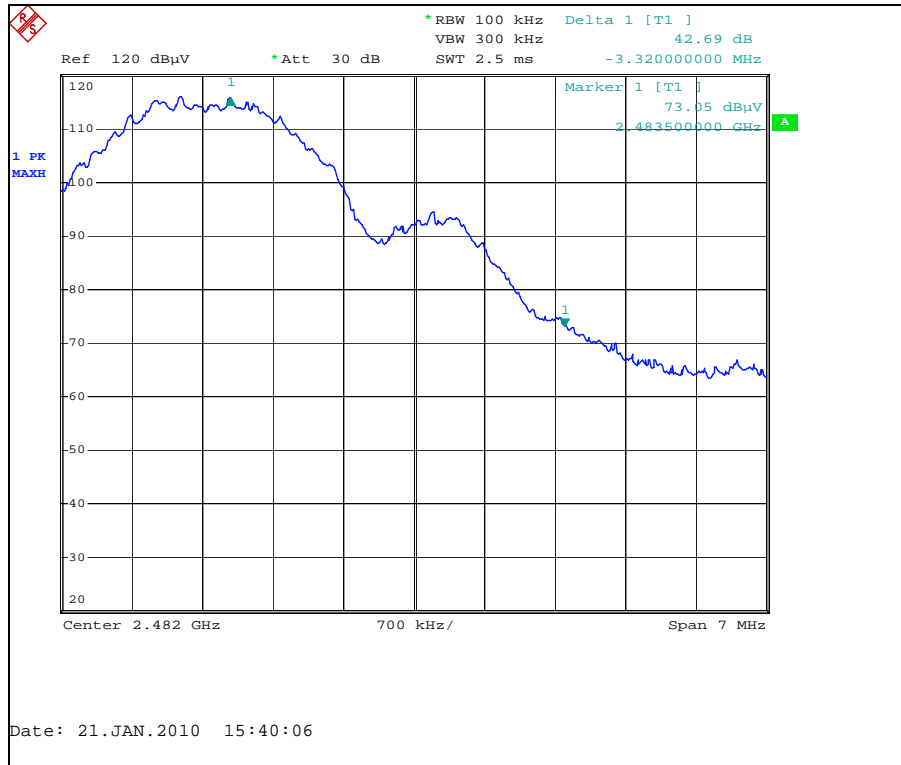

Figure 7.6.1.2-2: Upper Band-edge– Vpol

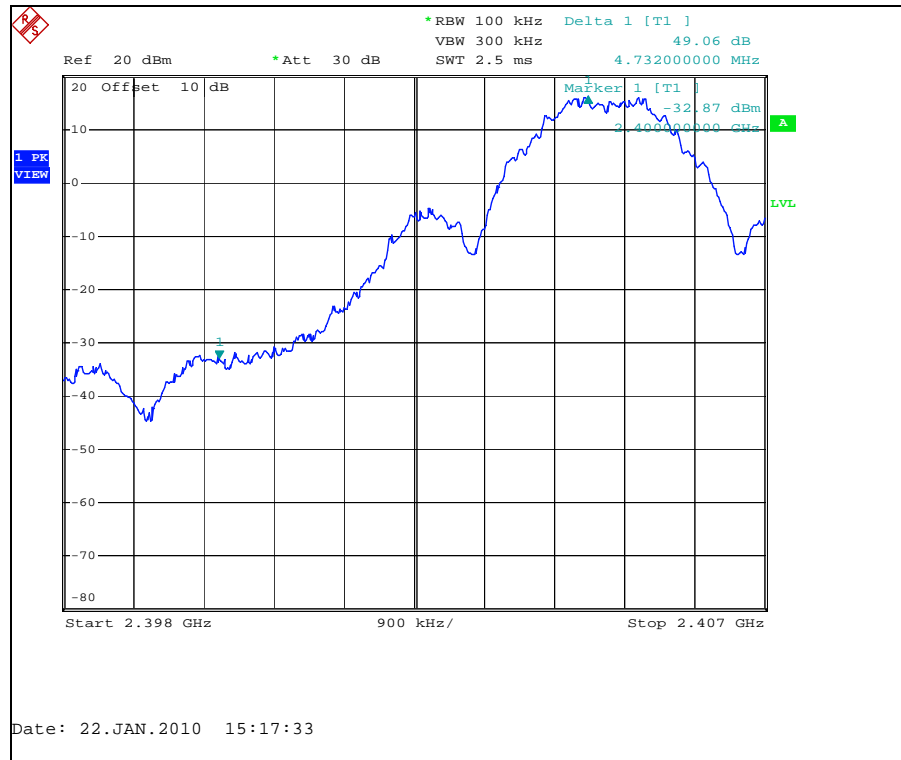

Figure 7.6.1.2-3: Lower Band-edge (Conducted)

7.6.2 RF Conducted Spurious Emissions

7.6.2.1 Measurement Procedure

The RF Conducted Spurious Emissions were measured in accordance with the FCC KDB Publication No. 558074 “Guidance on Measurements for Digital Transmission Systems (47 CFR 15.247)”. The RF output of the equipment under test was directly connected to the input of the Spectrum Analyzer. The EUT was investigated for conducted spurious emissions from 30MHz to 25GHz, 10 times the highest fundamental frequency. For each measurement, the spectrum analyzer’s RBW was set to 100 kHz and the VBW was set to 300 kHz. The peak detector and Max Hold function of the analyzer were utilized.

7.6.2.2 Measurement Results

In a 100 kHz bandwidth, the radio frequency power that was produced by the EUT emissions is at least 20 dB below that in the 100 kHz bandwidth within the band that contains the highest level of desired power. RF Conducted Emissions are displayed in Figures 7.6.2.2-1 through 7.6.2.2-9.

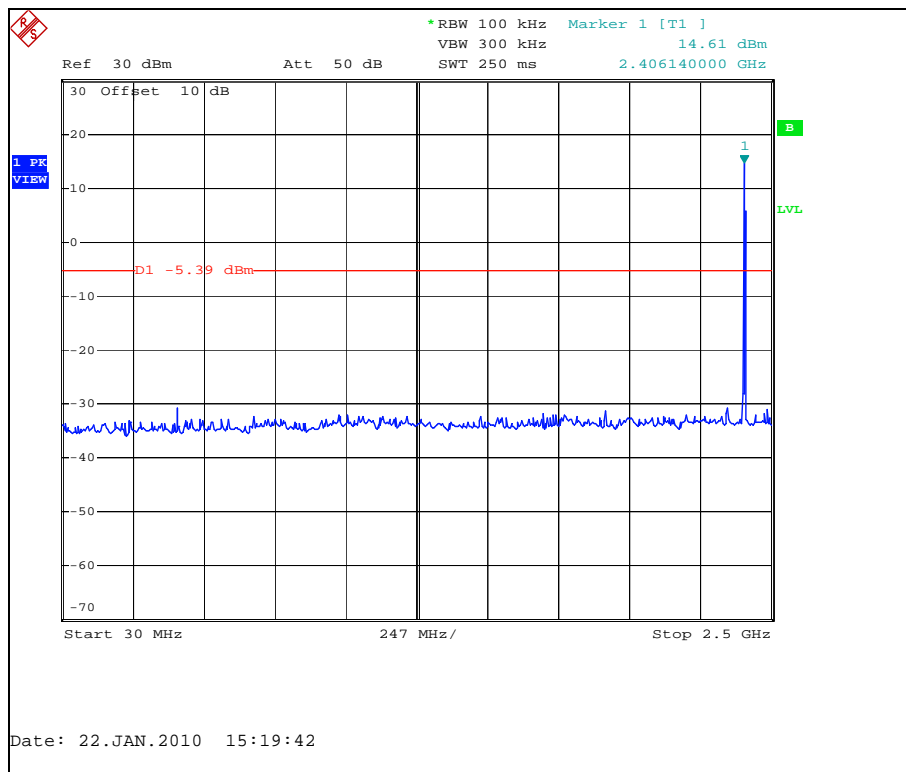

Figure 7.6.2.2-1: 30 MHz – 2.5 GHz – Low Channel

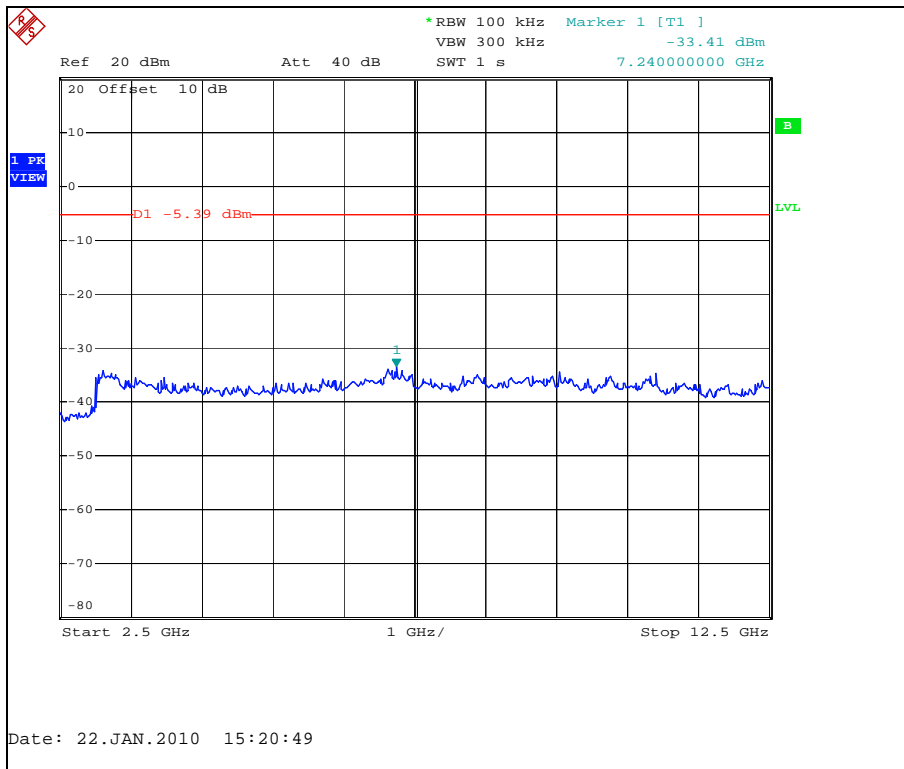

Figure 7.6.2.2-2: 2.5 GHz – 12.5 GHz – Low Channel

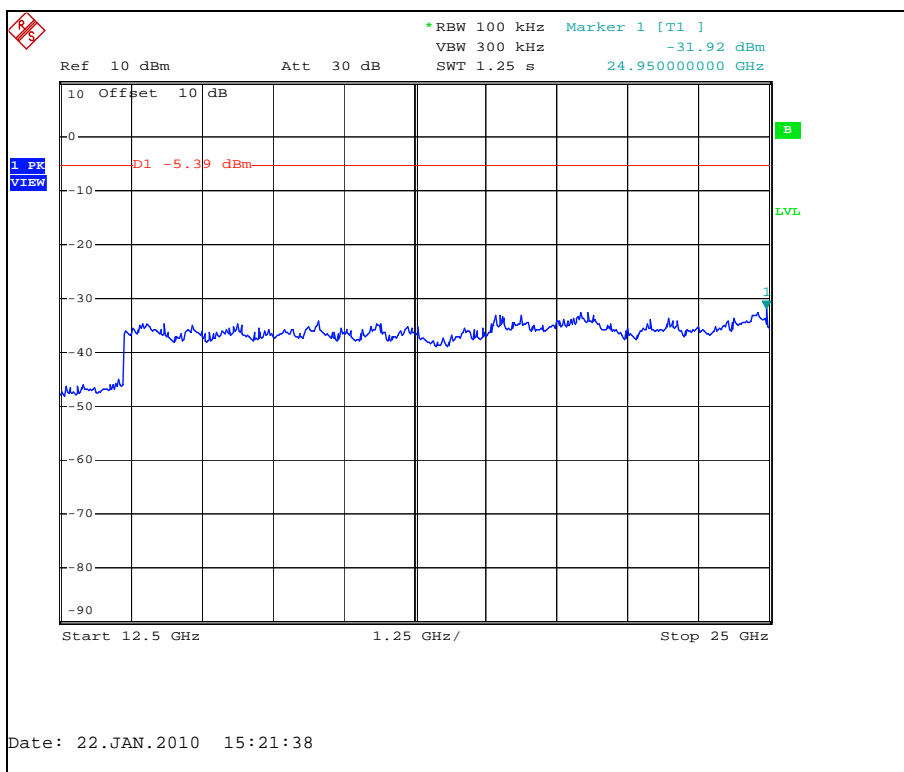

Figure 7.6.2.2-3: 12.5 GHz – 25 GHz – Low Channel

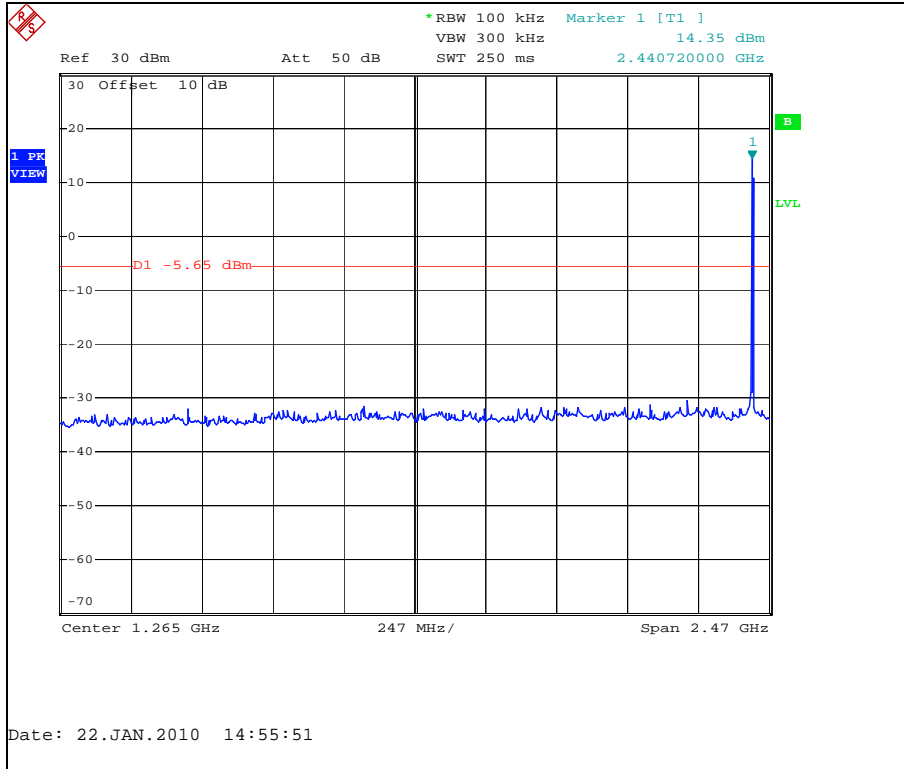

Figure 7.6.2.2-4: 30 MHz – 2.5 GHz –Mid Channel

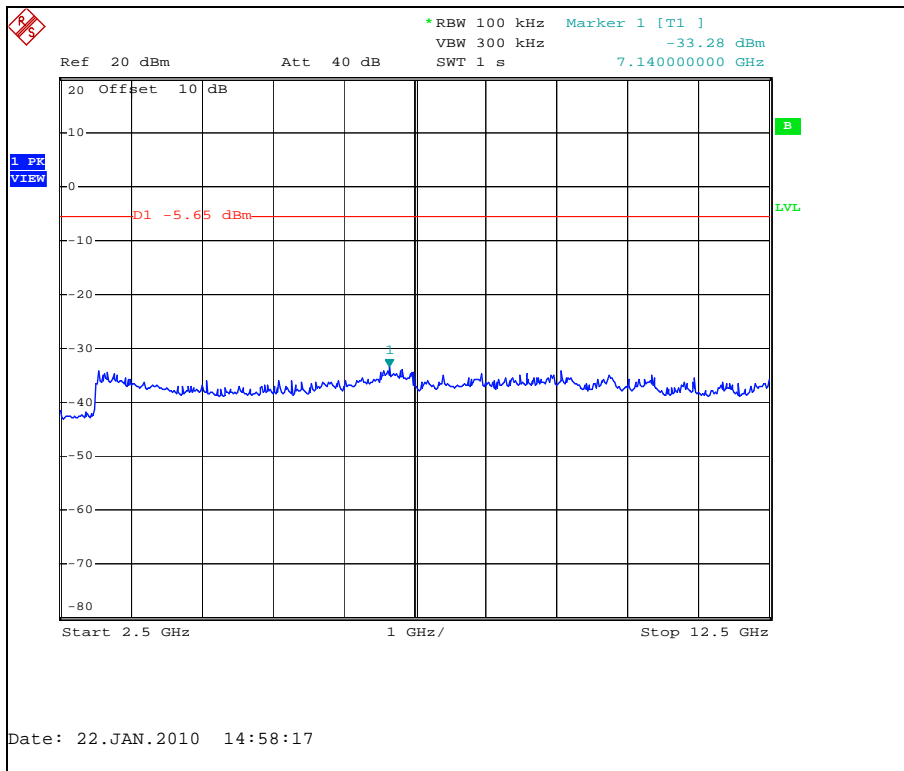

Figure 7.6.2.2-5: 2.5 GHz – 12.5 GHz – Mid Channel

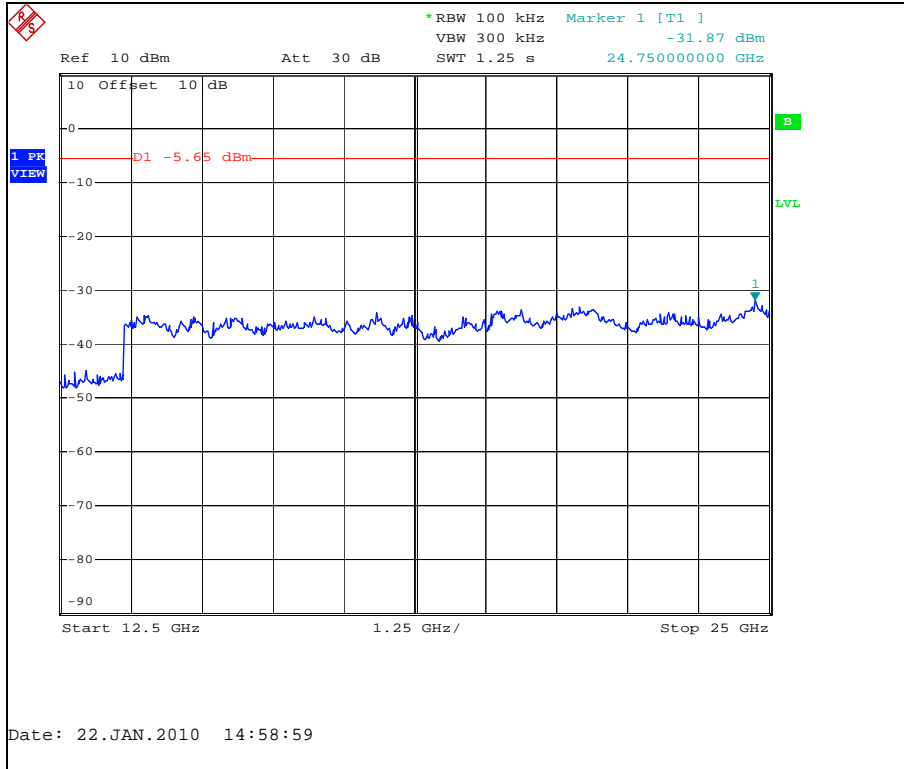

Figure 7.6.2.2-6: 12.5 GHz – 25 GHz – Mid Channel

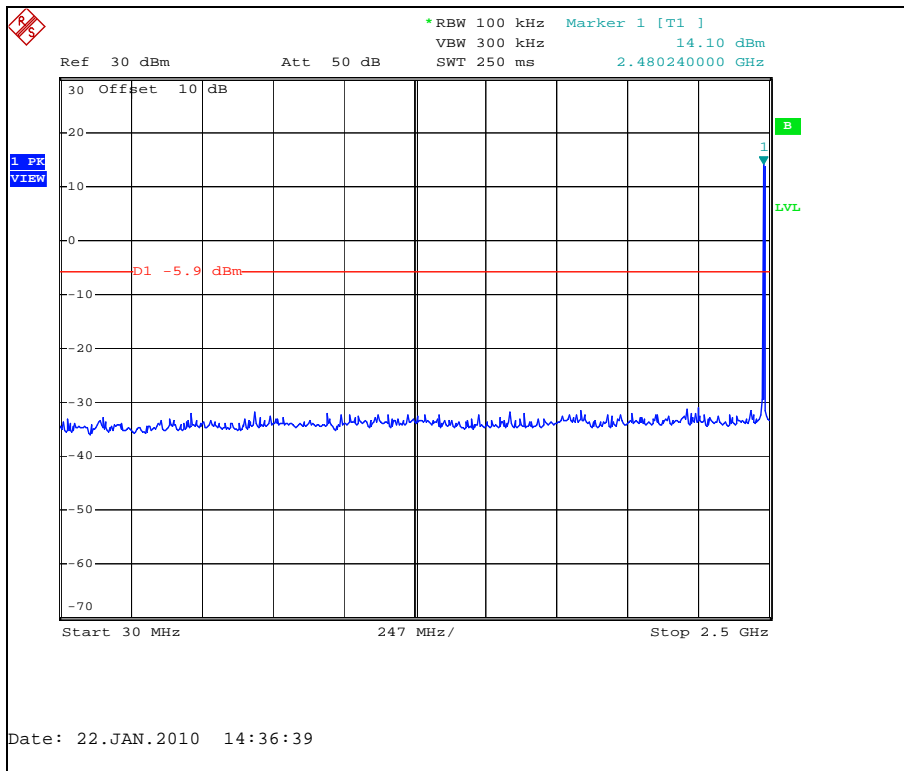

Figure 7.6.2.2-7: 30 MHz – 2.5 GHz – High Channel

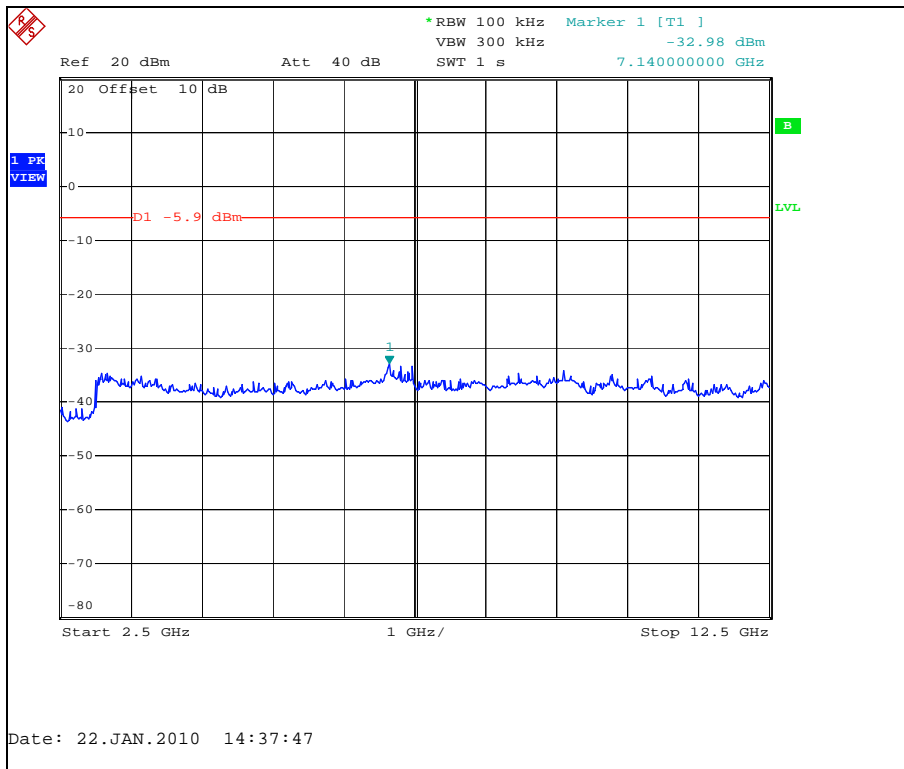

Figure 7.6.2.2-8: 2.5 GHz – 12.5 GHz –High Channel

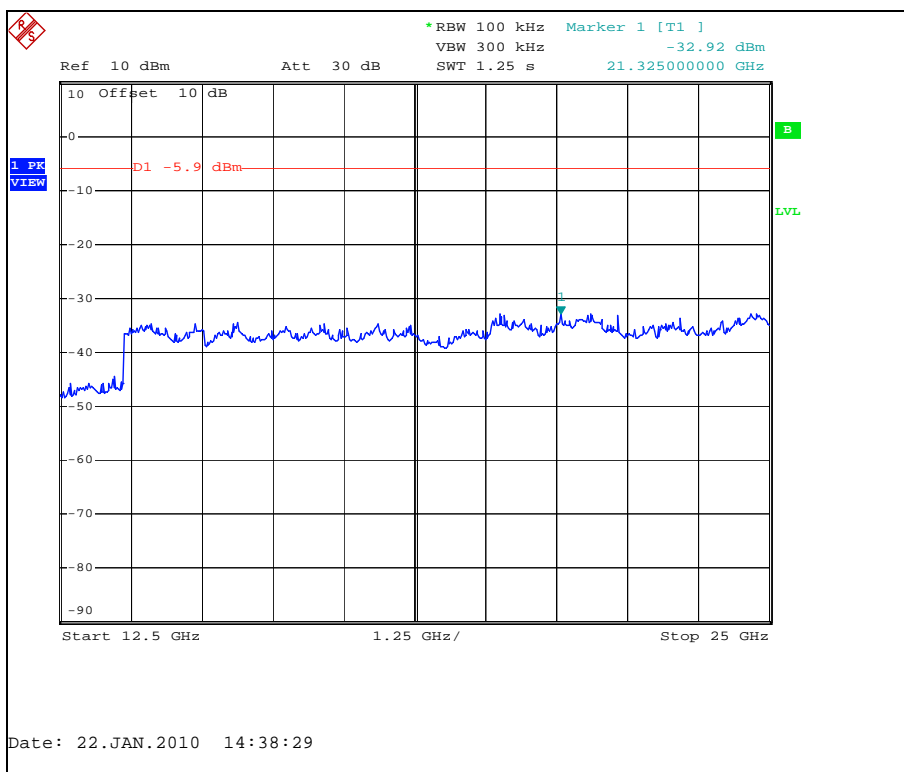

Figure 7.6.2.2-9: 12.5 GHz – 25 GHz –High Channel

7.6.3 Radiated Spurious Emissions (Restricted Bands) - FCC Sec. 15.205 IC: RSS-210 2.6**7.6.3.1 Measurement Procedure**

Radiated emissions tests were made over the frequency range of 30MHz to 25GHz, 10 times the highest fundamental frequency.

The EUT was rotated through 360° and the receive antenna height was varied from 1m to 4m so that the maximum radiated emissions level would be detected. For frequencies below 1000MHz, quasi-peak measurements were made using a resolution bandwidth RBW of 120 kHz and a video bandwidth VBW of 300 kHz. For frequencies above 1000MHz, peak and average measurements were made with RBW and VBW of 1 MHz and 3 MHz respectively. The average emissions were further corrected by applying the duty cycle correction of the EUT for comparison to the average limit.

Each emission found to be in a restricted band as defined by section 15.205 was compared to the radiated emission limits as defined in section 15.209.

The EUT can be collocated with Sensus Metering Systems module model IDTB002 FCC ID: SDBIDTB002, IC: 2220A-IDTB002 when integrated in electric utility meters. Radiated inter-modulation testing was performed with both modules simultaneously transmitting when integrated in utility meters type 1S, 2S, and 12S. All spurious emission levels were below the specified limit and therefore not reported.

7.6.3.2 Duty Cycle Correction

For average radiated measurements, using a 12.8% duty cycle, the measured level was reduced by a factor 17.9dB. The duty cycle correction factor is determined using the formula: $20\log(12.8/100) = 17.9\text{dB}$.

A detailed analysis of the duty cycle timing is provided in the Theory of Operation accompanying this report.

7.6.3.3 Measurement Results

Radiated spurious emissions found in the band of 30MHz to 25GHz are reported in the tables below.

Table 7.6.3.3-1: Radiated Spurious Emissions Tabulated Data – 2405MHz

Frequency (MHz)	Level (dBuV)		Antenna Polarity (H/V)	Correction Factors (dB)	Corrected Level (dBuV/m)		Limit (dBuV/m)		Margin (dB)	
	pk	Qpk/Avg			pk	Qpk/Avg	pk	Qpk/Avg	pk	Qpk/Avg
4810	61.67	55.04	H	3.20	64.87	40.38	74.0	54.0	9.10	13.60
4810	65.73	60.25	V	3.20	68.93	45.59	74.0	54.0	5.10	8.40
12025	54.23	45.19	H	16.39	70.62	43.72	83.5	63.5	12.90	19.80
12025	58.90	51.36	V	16.39	75.29	49.89	83.5	63.5	8.20	13.60

* Note: All emissions above 12025 MHz were attenuated below the permissible limit.

Table 7.6.3.3-2: Radiated Spurious Emissions Tabulated Data – 2440MHz

Frequency (MHz)	Level (dBuV)		Antenna Polarity (H/V)	Correction Factors (dB)	Corrected Level (dBuV/m)		Limit (dBuV/m)		Margin (dB)	
	pk	Qpk/Avg			pk	Qpk/Avg	pk	Qpk/Avg	pk	Qpk/Avg
4880	60.25	54.71	H	3.46	63.71	40.31	74.0	54.0	10.30	13.70
4880	62.30	57.27	V	3.46	65.76	42.87	74.0	54.0	8.20	11.10
7320	52.68	43.97	H	8.31	60.99	34.43	74.0	54.0	13.00	19.60
7320	57.58	50.52	V	8.31	65.89	40.98	74.0	54.0	8.10	13.00
12200	54.69	45.47	H	17.53	72.22	45.14	83.5	63.5	11.30	18.40
12200	59.76	52.50	V	17.53	77.29	52.17	83.5	63.5	6.20	11.30

* Note: All emissions above 12200 MHz were attenuated below the permissible limit.

Table 7.6.3.3-3: Radiated Spurious Emissions Tabulated Data – 2480MHz

Frequency (MHz)	Level (dBuV)		Antenna Polarity (H/V)	Correction Factors (dB)	Corrected Level (dBuV/m)		Limit (dBuV/m)		Margin (dB)	
	pk	Qpk/Avg			pk	Qpk/Avg	pk	Qpk/Avg	pk	Qpk/Avg
4960	59.16	53.98	H	3.75	62.91	39.88	74.0	54.0	11.10	14.10
4960	61.06	56.31	V	3.75	64.81	42.21	74.0	54.0	9.20	11.80
7440	55.68	47.88	H	8.42	64.10	38.45	74.0	54.0	9.90	15.60
7440	60.20	53.60	V	8.42	68.62	44.17	74.0	54.0	5.40	9.80
12400	54.72	46.36	H	18.83	73.55	47.33	83.5	63.5	10.00	16.20
12400	57.48	49.30	V	18.83	76.31	50.27	83.5	63.5	7.20	13.20

* Note: All emissions above 12400 MHz were attenuated below the permissible limit.

7.6.3.4 Sample Calculation:

$$R_C = R_U + CF_T$$

Where:

- CF_T = Total Correction Factor (AF+CA+AG)-DC (Average Measurements Only)
- R_U = Uncorrected Reading
- R_C = Corrected Level
- AF = Antenna Factor
- CA = Cable Attenuation
- AG = Amplifier Gain
- DC = Duty Cycle Correction Factor

Example Calculation: Peak

Corrected Level: 61.67+ 3.20 = 64.87dBuV/m

Margin: 74dBuV/m – 64.87dBuV/m = 9.1dB

Example Calculation: Average

Corrected Level: 55.04 + 3.20 – 17.86 = 40.38dBuV

Margin: 54dBuV – 40.38dBuV = 13.6dB

7.7 Peak Power Spectral Density- FCC Section 15.247(e) IC: RSS-210 A8.2(b)

7.7.1 Measurement Procedure

The power spectral density was measured in accordance with the FCC KDB Publication No. 558074 "Guidance on Measurements for Digital Transmission Systems (47 CFR 15.247)". The emission peaks within the pass band were located and zoomed in on. The spectrum analyzer RBW was set to 3 kHz and VBW 10 kHz. Span was adjusted to 500 kHz and the sweep time was calculated to be 168s (Span/3 kHz).

7.7.2 Measurement Results

Results are shown below in table 7.7.2-1 and figures 7.7.2-1 – 7.7.2-3:

Table 7.7.2-1: Peak Power Spectral Density

Frequency (MHz)	PSD Level (dBm)
2405	5.01
2440	5.04
2480	5.66

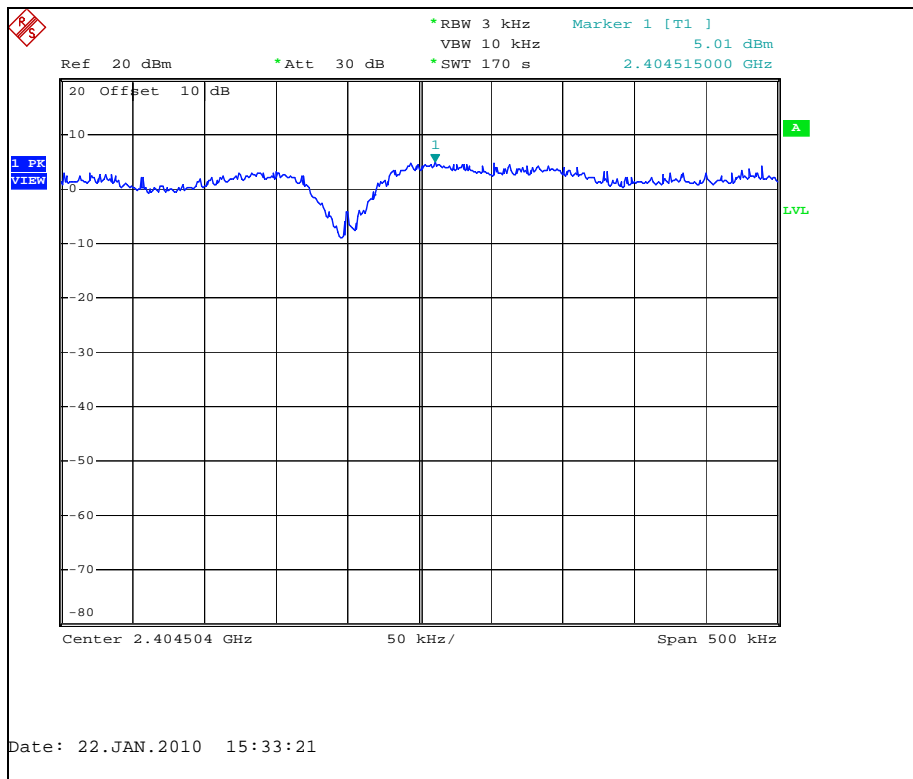

Figure 7.7.2-1: Power Spectral Density Plot – Low Channel

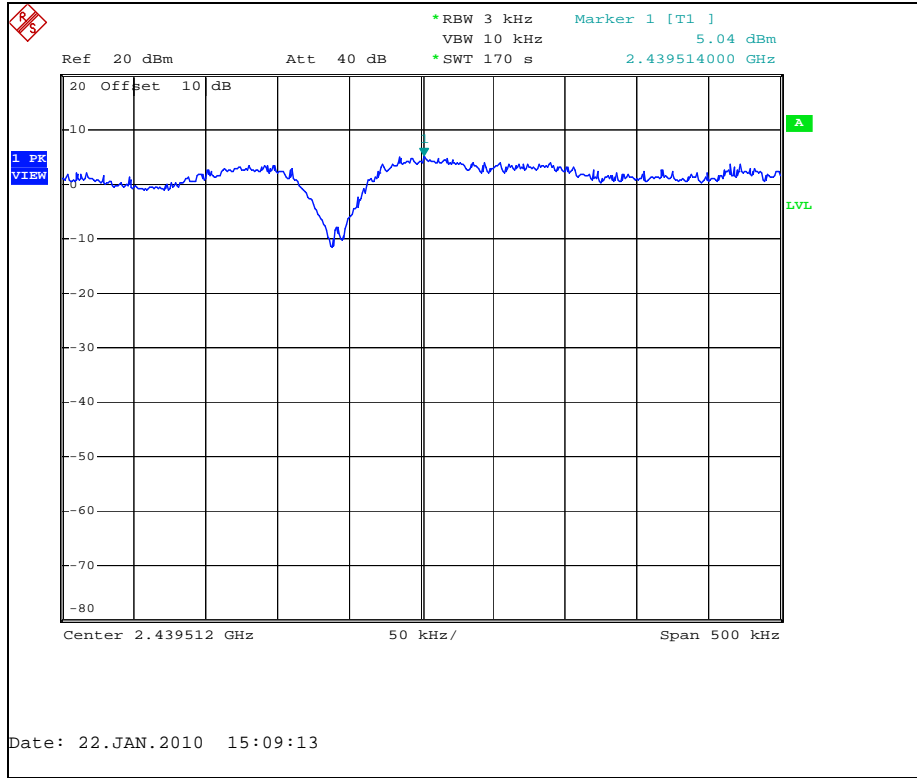

Figure 7.7.2-2: Power Spectral Density Plot – Mid Channel

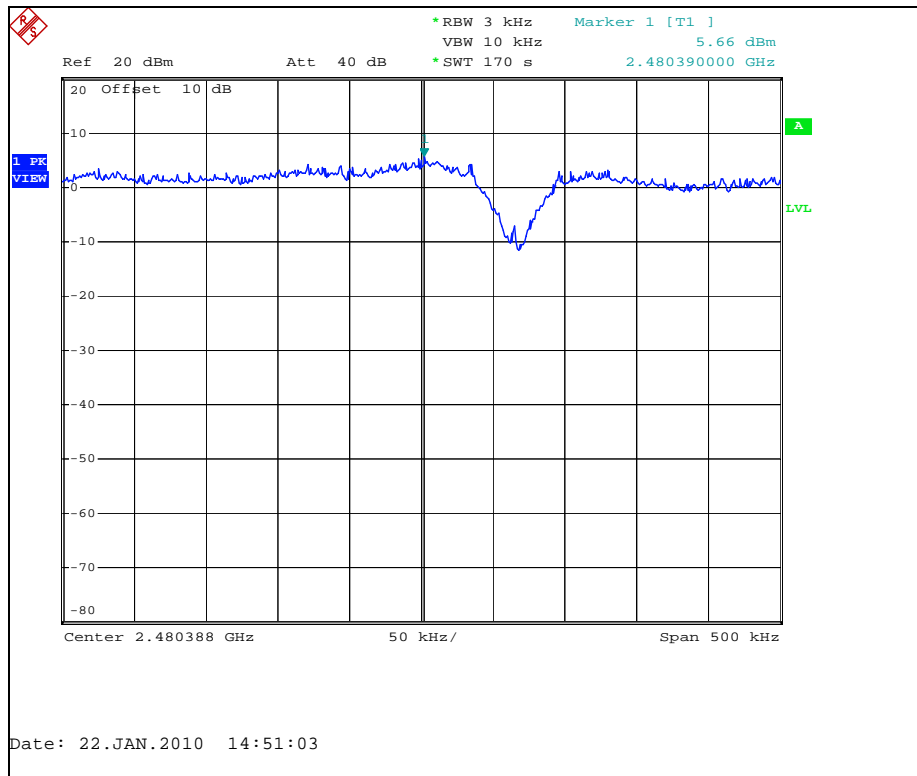

Figure 7.7.2-3: Power Spectral Density Plot – High Channel

8 CONCLUSION

In the opinion of ACS, Inc. the ZIGMOD10, manufactured by Sensus Metering Systems, Inc. meets the requirements of FCC Part 15 subpart C and Industry Canada's Radio Standards Specification RSS-210.

END REPORT