

Certification Test Report

**FCC ID: SDBWFL
IC: 2220A-WFL**

**FCC Rule Part: CFR 47 Part 24 Subpart D, Part 90 Subpart I, Part 101
Subpart C
IC Radio Standards Specification: RSS 119, RSS 134**

ACS Report Number: 09-0282.W06.11.A

Applicant: Sensus Metering Systems
Model: WFL

Test Begin Date: August 19, 2009
Test End Date: September 4, 2009

Report Issue Date: December 3, 2010



FOR THE SCOPE OF ACCREDITATION UNDER LAB Code 200612-0

This report must not be used by the client to claim product certification, approval, or endorsement by NVLAP, NIST, or any agency of the Federal Government.

A handwritten signature in black ink, appearing to read 'Kirby Munroe', is written over a horizontal line.

Reviewed by: _____
Kirby Munroe
Director, Wireless Certifications
ACS, Inc.

This test report shall not be reproduced except in full. This report may be reproduced in part with prior written consent of ACS, Inc. The results contained in this report are representative of the sample(s) submitted for evaluation.
This report contains 56 pages

Table of Contents

1.0 GENERAL	3
1.1 Purpose	3
1.2 Product Description	3
1.3 Test Methodology	3
1.3.1 Test Configurations and Justification	3
1.3.2 In-Band Testing Methodology	3
1.4 Emission Designators	4
2.0 TEST FACILITIES	5
2.1 Location	5
2.2 Laboratory Accreditations/Recognitions/Certifications	5
2.3 Radiated Emissions Test Site Description	6
2.3.1 Semi-Anechoic Chamber Test Site	6
2.3.2 Open Area Tests Site (OATS)	7
2.4 Conducted Emissions Test Site Description	8
3.0 APPLICABLE STANDARD REFERENCES	8
4.0 LIST OF TEST EQUIPMENT	9
5.0 SUPPORT EQUIPMENT	10
6.0 EQUIPMENT UNDER TEST SETUP AND BLOCK DIAGRAM	10
7.0 SUMMARY OF TESTS	11
7.1 RF Power Output	11
7.1.1 Measurement Procedure	11
7.1.2 Measurement Results	11
7.2 Occupied Bandwidth (Emission Limits)	16
7.2.1 Measurement Procedure	16
7.2.2 Measurement Results	16
7.3 Spurious Emissions at Antenna Terminals	36
7.3.1 Measurement Procedure	36
7.3.2 Measurement Results	36
7.4 Field Strength of Spurious Emissions	45
7.4.1 Measurement Procedure	45
7.4.2 Measurement Results – 520x (“T” Board)	45
7.4.3 Measurement Results – 510x (SOH Board)	49
7.5 Frequency Stability	52
7.5.1 Measurement Procedure	52
7.5.2 Measurement Results	53
7.6 Radiated Emissions (Unintentional Radiators/Receiver)	56
7.6.1 Measurement Procedure	56
7.6.2 Measurement Results – 520x (“T” Board)	56
7.6.3 Measurement Results – 510x (SOH Board)	56
8.0 CONCLUSION	56

1.0 GENERAL

1.1 Purpose

The purpose of this report is to demonstrate compliance with Part 2 Subpart J, Part 24 Subpart D, Part 90 Subpart I, and Part 101 Subpart C of the FCC's Code of Federal Regulations; and RSS 119 and 134 of Industry Canada's Radio Standard Specifications.

1.2 Product Description

The WFL is Two Way Endpoint device used in utility metering applications. It is a battery operated transceiver hardware / software architecture which is able to support Walk By, Drive By, and Fixed Base 2-Watt operation.

The WFL model applies to two PCB variants, at the modular level. Where the two boards differ is in the endpoint form factor and end use. This difference requires a unique shape of the PCB for the different endpoint form factors. The 510x or SOH board is square and located above ground on the side of the house. The 520x is the pit version or "T" board. Both PCB variants are electrically identical with respect to the RF design.

Manufacturer Information:
Sensus Metering Systems, Inc.
400 Perimeter Park Drive, Suite K
Morrisville, NC 27560

Test Sample Serial Numbers: ACS#7 (RF conducted), ACS#3, ACS#8 (Radiated)

Test Sample Condition: The test samples were provided in good working order with no visible defects.

1.3 Test Methodology

1.3.1 Test Configurations and Justification

For RF conducted measurements, the EUT was modified with an external RF connector to the PCB. The EUT utilizes non-detachable antennas for normal operation but for RF conducted testing the antennas were disconnected and a 50-Ohm test cable soldered (with the appropriate ground connection) to the PCB.

Both PCB variants (510x SOH Board & 520x "T" Board) are electrically identical with respect to the RF design, therefore only one version was evaluated for RF conducted measurements. Considering the models are electrically identical there are no differences in the measured characteristics between each. Based on the differences in the PCB size and shape, both variants were evaluated for radiated emissions.

The WFL operates using various modulation formats/modes all of which were evaluated and worst case data present where applicable.

1.3.2 In-Band Testing Methodology

For testing in accordance with 47 CFR 2.1046-2.1057, OET/Lab recommends that the following be used to select test frequencies for licensed devices:

Frequency range over which device operates	Number of frequencies	Location in the range of operation
1 MHz or less	1	Middle
1 to 10 MHz	2	1 near top and 1 near bottom
10 to 100 MHz	3	1 near top, 1 near middle and 1 near bottom

The WFL modules are designed to operate in multiple bands under the requirements of CFR 47 Parts 24, 90, and 101. The following is a list of the frequency bands of operation sorted based on the FCC rule parts in which the band is associated.

CFR Title 47 Rule Part	Frequency Band of Operation (MHz)
24D	901.0 - 902.0
24D	930.0 - 931.0
24D	940.0 - 941.0
90	896.01875 - 901.0*
90	935.0 - 940.0
101	928.85 - 929.0
101	932.0 - 932.5
101	941.0 - 941.5
101	959.85 - 960.0

Based on the requirements set forth in accordance 47 CFR 2.1046-2.1057 as stated above, the methodology in selecting the places to test in the available bands of operation is outlined in the following table.

CFR Title 47 Rule Part	Frequency Band of Operation (MHz)	Location in the Range of Operation
90	896.01875 - 901.0*	1 near top and 1 near bottom
24D	901.0 - 902.0	
101	928.85 - 929.0	Middle
24D	930.0 - 931.0	Middle
101	932.0 - 932.5	Middle
90	935.0 - 940.0	1 near top and 1 near bottom
24D	940.0 - 941.0	
101	941.0 - 941.5	
101	959.85 - 960.0	Middle

The data provided in this report is sorted based on the rule part.

*NOTE: The EUT does not comply at the extreme lower channel within the 896 – 901 MHz frequency band therefore the lowest channel for showing compliance was evaluated at 896.01875MHz.

1.4 Emission Designators

The WFL transceiver produces nine distinct modulation formats. The emissions designators for the nine modulation types used by the WFL transceiver are as follows:

EMISSIONS DESIGNATORS:

- Normal Mode: 9K60F2D (7-FSK)
- Double Density Mode: 9K60F2D (13-FSK)
- C&I Mode: 4K80F2D (7-FSK)
- Priority Mode: 4K80F2D (13-FSK)
- Boost Mode: 1K10F2D (7-FSK)
- MPass Mode (5K): 5K90F1D (2-GFSK)
- MPass Mode (10K): 11K80F1D (2-GFSK)
- MPass Mode (12.5K): 14K75F1D (2-GFSK)
- Amplitude Shift Keying (ASK): 10K30F2D

2.0 TEST FACILITIES

2.1 Location

The radiated and conducted emissions test sites are located at the following address:

Advanced Compliance Solutions
5015 B.U. Bowman Drive
Buford, GA 30518
Phone: (770) 831-8048
Fax: (770) 831-8598

2.2 Laboratory Accreditations/Recognitions/Certifications

ACS is accredited to ISO/IEC 17025 by the National Institute of Standards and Technology under their National Voluntary Laboratory Accreditation Program (NVLAP), Lab Code 200612-0. Unless otherwise specified, all tests methods described within this report are covered under the ISO/IEC 17025 scope of accreditation.

The Semi-Anechoic Chamber Test Site, Open Area Test Site (OATS) and Conducted Emissions Site have been fully described, submitted to, and accepted by the FCC, Industry Canada and the Japanese Voluntary Control Council for Interference by information technology equipment.

FCC Registration Number: 894540

Industry Canada Lab Code: IC 4175A-1

VCCI Member Number: 1831

- VCCI OATS Registration Number R-1526
- VCCI Conducted Emissions Site Registration Number: C-1608

2.3 Radiated Emissions Test Site Description

2.3.1 Semi-Anechoic Chamber Test Site

The Semi-Anechoic Chamber Test Site consists of a 20' x 30' x 18' shielded enclosure. The chamber is lined with Toyo Ferrite Grid Absorber, model number FFG-1000. The ferrite tile grid is 101 x 101 x 19mm thick and weighs approximately 550 grams. These tiles are mounted on steel panels and installed directly on the inner walls of the chamber.

The turntable is 150cm in diameter and is located 160cm from the back wall of the chamber. The chamber is grounded via 1 - 8' copper ground rod, installed at the center of the back wall, it is bound to the ground plane using 3/4" stainless steel braided cable.

The turntable is all steel, flush mounted table installed in an all steel frame. The table is remotely operated from inside the control room located 25' from the range. The turntable is electrically bonded to the surrounding ground plane via steel fingers installed on the edge of the turn table. The steel fingers make constant contact with the ground plane during operation.

Behind the turntable is a 3' x 6' x 4' deep shielded pit used for support equipment if necessary. The pit is equipped with 1 - 4" PVC chases from the turntable to the pit that allow for cabling to the EUT if necessary. The underside of the turntable can be accessed from the pit so cables can be supplied to the EUT from the pit.

A diagram of the Semi-Anechoic Chamber Test Site is shown in Figure 2.3-1 below:

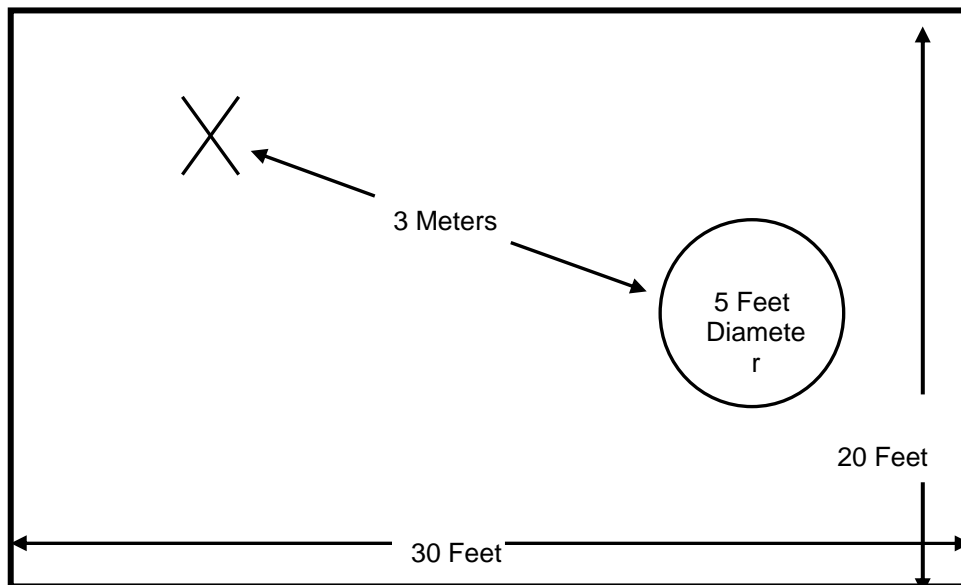

Figure 2.3-1: Semi-Anechoic Chamber Test Site

2.3.2 Open Area Tests Site (OATS)

The open area test site consists of a 40' x 66' concrete pad covered with a perforated electro-plated galvanized sheet metal. The perforations in the sheet metal are 1/8" holes that are staggered every 3/16". The individual sheets are placed to overlap each other by 1/4" and are riveted together to provide a continuous seam. Rivets are spaced every 3" in a 3 x 20 meter perimeter around the antenna mast and EUT area. Rivets in the remaining area are spaced as necessary to properly secure the ground plane and maintain the electrical continuity.

The entire ground plane extends 12' beyond the turntable edge and 16' beyond the antenna mast when set to a 10 meter measurement distance. The ground plane is grounded via 4 - 8' copper ground rods, each installed at a corner of the ground plane and bound to the ground plane using 3/4" stainless steel braided cable.

The turntable is an all aluminum 10' flush mounted table installed in an all aluminum frame. The table is remotely operated from inside the control room located 40' from the range. The turntable is electrically bonded to the surrounding ground plane via steel fingers installed on the edge of the turn table. The steel fingers make constant contact with the ground plane during operation.

Adjacent to the turntable is a 7' x 7' square and 4' deep concrete pit used for support equipment if necessary. The pit is equipped with 5 - 4" PVC chases from the pit to the control room that allow for cabling to the EUT if necessary. The underside of the turntable can be accessed from the pit so cables can be supplied to the EUT from the pit. The pit is covered with 2 sheets of 1/4" diamond style re-enforced steel sheets. The sheets are painted to match the perforated steel ground plane; however the underside edges have been masked off to maintain the electrical continuity of the ground plane. All reflecting objects are located outside of the ellipse defined in ANSI C63.4.

A diagram of the Open Area Test Site is shown in Figure 2.3-2 below:

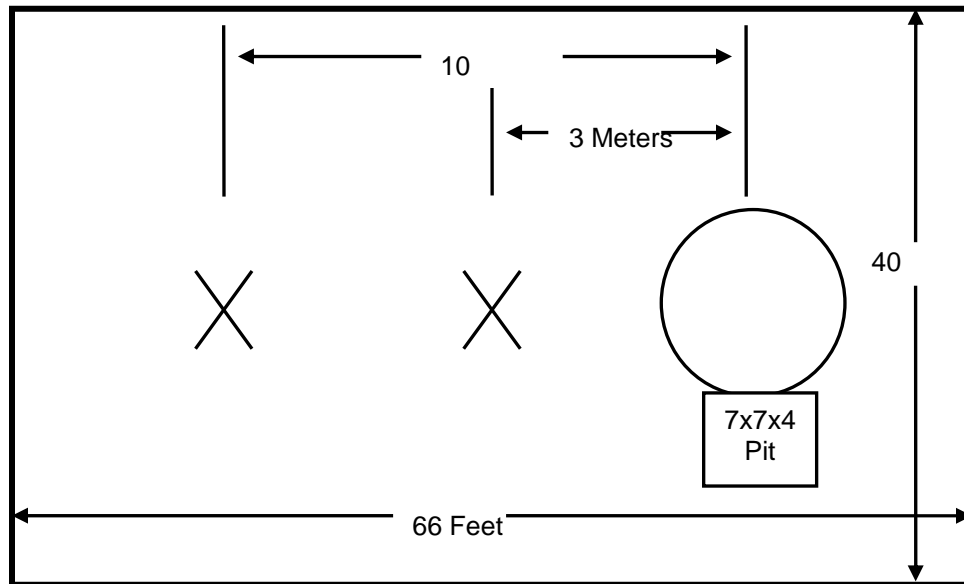

Figure 2.3-2: Open Area Test Site

2.4 Conducted Emissions Test Site Description

The AC mains conducted EMI site is located in the main EMC lab. It consists of an 8' x 8' solid aluminum horizontal group reference plane (GRP) bonded every 3" to an 8' X 8' vertical ground plane.

The site is of sufficient size to test table top and floor standing equipment in accordance with section 6.1.4 of ANSI C63.4.

A diagram of the room is shown below in figure 4.1.3-1:

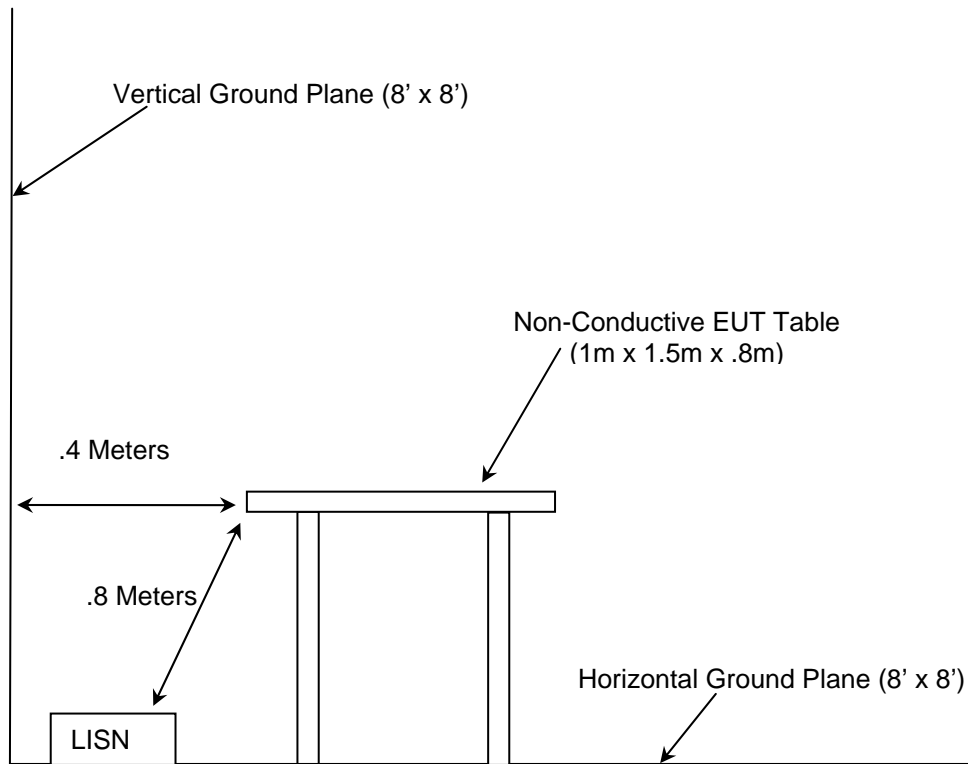

Figure 2.4-1: AC Mains Conducted EMI Site

3.0 APPLICABLE STANDARD REFERENCES

The following standards were used:

- 1 - ANSI C63.4-2003: Method of Measurements of Radio-Noise Emissions from Low-Voltage Electrical and Electronic Equipment in the 9KHz to 40GHz - 2003
- 2 - US Code of Federal Regulations (CFR): Title 47, Part 2, Subpart J: Equipment Authorization Procedures - 2010
- 3 - US Code of Federal Regulations (CFR): Title 47, Part 24, Subpart D: Personal Communication Service - 2010
- 4 - US Code of Federal Regulations (CFR): Title 47, Part 90, Subpart I: Private Land Mobile Radio Services - 2010
- 5 - US Code of Federal Regulations (CFR): Title 47, Part 101, Subpart C: Fixed Microwave Services – 2010
- 6 – TIA-603-C: Land Mobile FM or PM - Communications Equipment - Measurement and Performance Standards – 2004
- 7 - Industry Canada Radio Standards Specification: RSS-119 - Land Mobile and Fixed Radio Transmitters and Receivers Operating in the Frequency Range 27.41-960 MHz - Issue 10, April 2010
- 8 - Industry Canada Radio Standards Specification: RSS-134 - 900 MHz Narrowband Personal Communications Services - Issue 1, Revision 1, March 25, 2000

4.0 LIST OF TEST EQUIPMENT

The calibration interval of test equipment is annually or the manufacturer's recommendations. Where the calibration interval deviates from the annual cycle based on the instrument manufacturer's recommendations, it shall be stated below.

Table 4-1: Test Equipment

Equipment Calibration Information					
ACS#	Mfg.	Eq. type	Model	S/N	Cal. Due
1	Rohde & Schwarz	Spectrum Analyzers	ESMI - Display	833771/007	09-19-2009
2	Rohde & Schwarz	Spectrum Analyzers	ESMI-Receiver	839587/003	09-19-2009
22	Agilent	Amplifiers	8449B	3008A00526	10-22-2009
25	Chase	Antennas	CBL6111	1043	09-02-2010
30	Spectrum Technologies	Antennas	DRH-0118	970102	05-08-2010
140	Thermotron	Environmental Chamber	SM-16C	19639	08-30-2010
167	ACS	Cable Set	Chamber EMI Cable Set	167	02-06-2010 (See Note1)
222	Andrew	Cables	F1-SMSM	473703-A0138A	08-14-2010 (See Note1)
277	EMCO	Antennas	93146 9904	5199	09-18-2010
283	Rohde & Schwarz	Spectrum Analyzers	FSP40	1000033	09-19-2009
291	Florida RF Cables	Cables	SMRE-200W-12.0-SMRE	None	11-24-2009 (See Note1)
292	Florida RF Cables	Cables	SMR-290AW-480.0-SMR	None	11-24-2009 (See Note1)
321	Hewlett Packard	Amplifiers	HPC 8447D	1937A02809	10-08-2009
329	A.H.Systems	Antennas	SAS-571	721	08-04-2010
337	Microwave Circuits	Filters	H1G513G1	282706	07-17-2010 (See Note1)
338	Hewlett Packard	Amplifiers	8449B	3008A01111	10-22-2009
340	Aeroflex/Weinschel	Attenuators	AS-20	7136	10-22-2009 (See Note2)
422	Florida RF	Cables	SMS-200AW-72.0-SMR	805	02-05-2010 (See Note1)
NA	Agilent	Signal Generator	E8257D	MY46521977	02-23-2010

Note1: Items characterized on an annual cycle. The date shown indicates the next characterization due date.

Note2: Items verified on an annual cycle. The date shown indicates the next verification due date.

5.0 SUPPORT EQUIPMENT

Table 5-1: Support Equipment

Diagram #	Manufacturer	Equipment Type	Model Number	Serial Number	FCC ID
1	OK Industries	DC Power Supply	PS73C	36095	NA

6.0 EQUIPMENT UNDER TEST SETUP AND BLOCK DIAGRAM

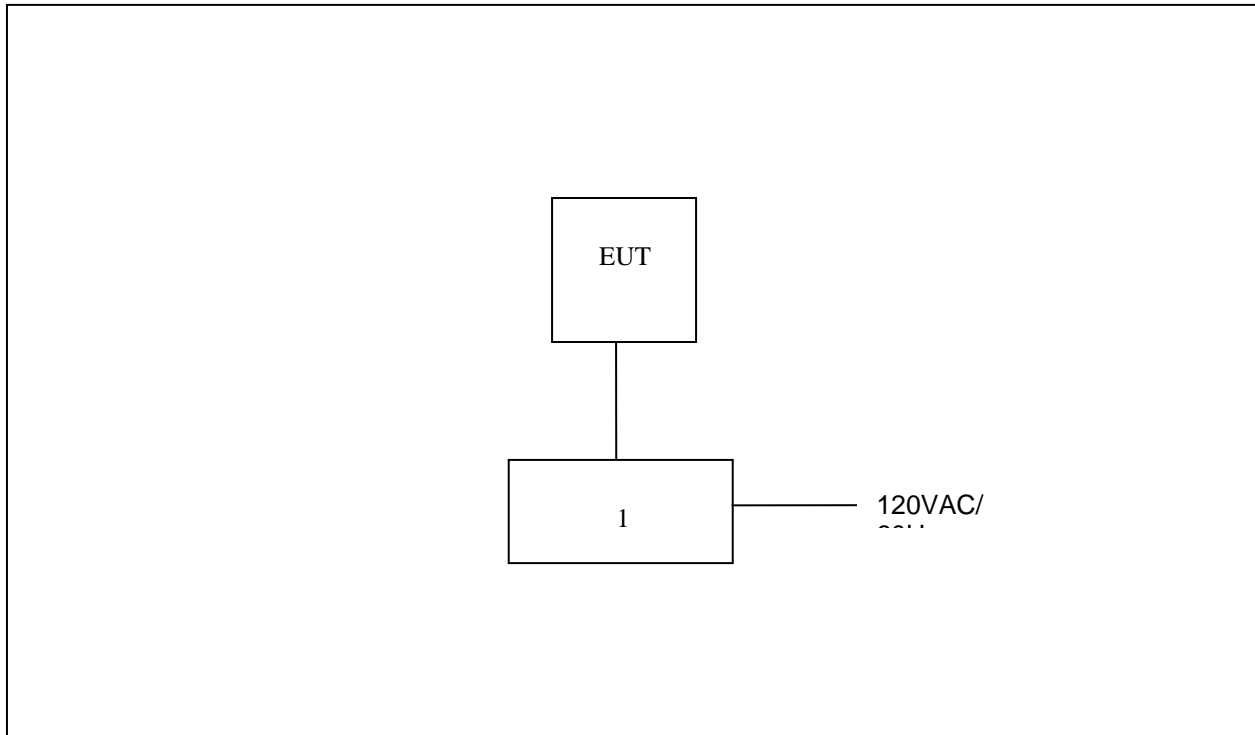

Figure 6-1: EUT Test Setup

* For RF conducted measurements, the transceiver was modified with an external 50-Ohm test cable soldered (with the appropriate ground connection) to the PCB.

7.0 SUMMARY OF TESTS

Along with the tabular data shown below, plots were taken of all signals deemed important enough to document.

7.1 RF Power Output

7.1.1 Measurement Procedure

The RF output of the equipment under test was directly connected to the input of the Spectrum Analyzer through a 10 dB passive attenuator. The resolution and video bandwidths of the spectrum analyzer were set at sufficient levels, >> signal bandwidth, to produce accurate results. The internal correction factors of the spectrum analyzer were employed to correct for any cable or attenuator losses. Results are shown below in Table 7.1.2-1 and Figure 7.1.2-1 through 7.1.2-8.

7.1.2 Measurement Results

Table 7.1.2-1: Peak Output Power

Frequency (MHz)	FCC Rule Part	Output Power (dBm)
901.9875	Part 24	29.23
930.5000	Part 24	30.08
896.0125	Part 90	29.42
935.0125	Part 90	30.17
928.9250	Part 101	30.07
932.2500	Part 101	30.04
941.4875	Part 101	30.10
959.9250	Part 101	30.25

Part 24.132/RSS-134 5.4(a)

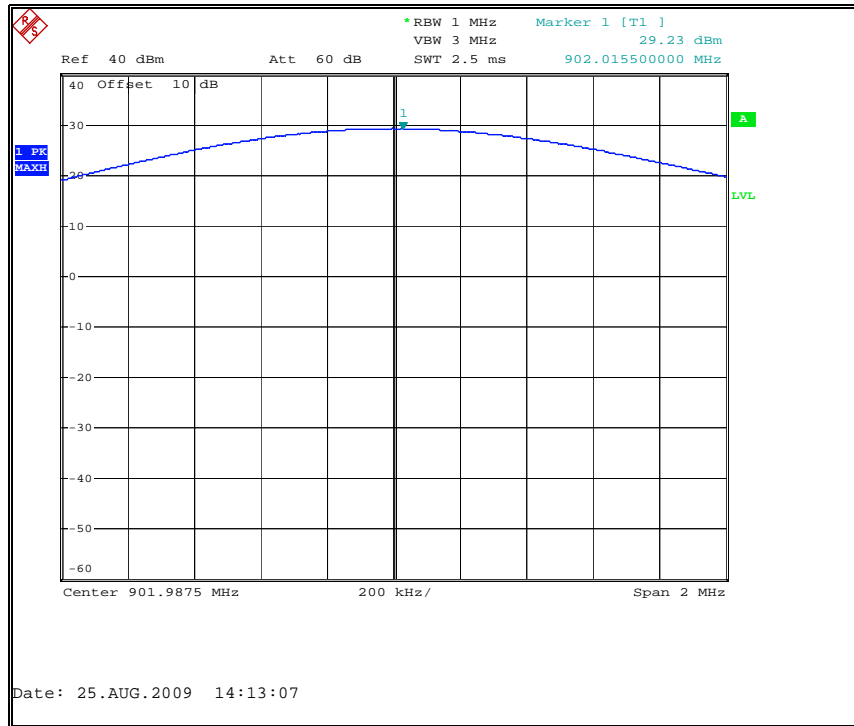

Figure 7.1.2-1: Peak Output Power 901.9875 MHz

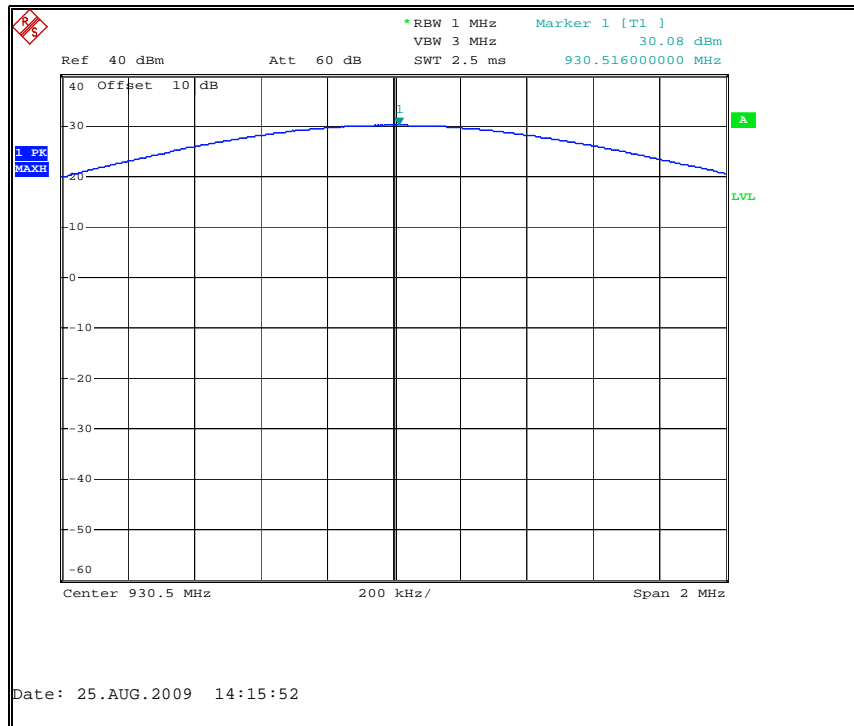

Figure 7.1.2-2: Peak Output Power 930.5 MHz

Part 90.635(d) / RSS-119 5.41

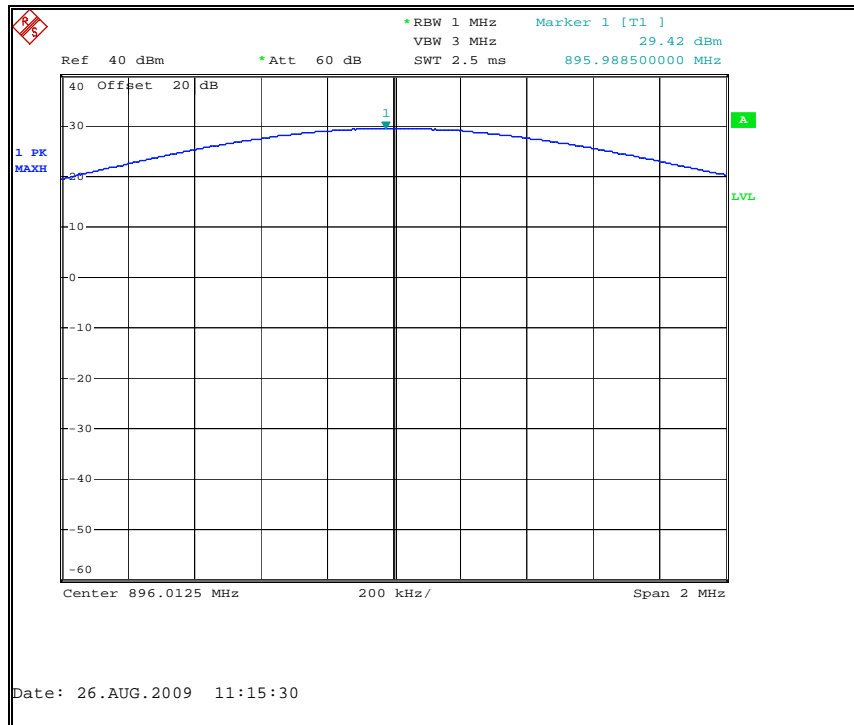

Figure 7.1.2-3: Peak Output Power 896.0125 MHz

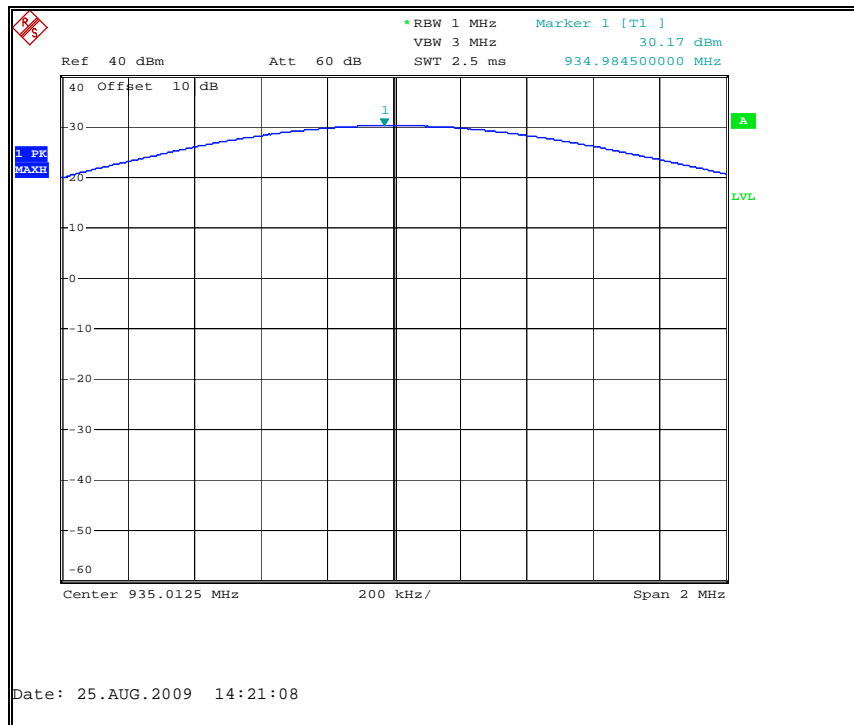

Figure 7.1.2-4: Peak Output Power 935.0125 MHz

Part 101.113(a) / RSS-119 5.41

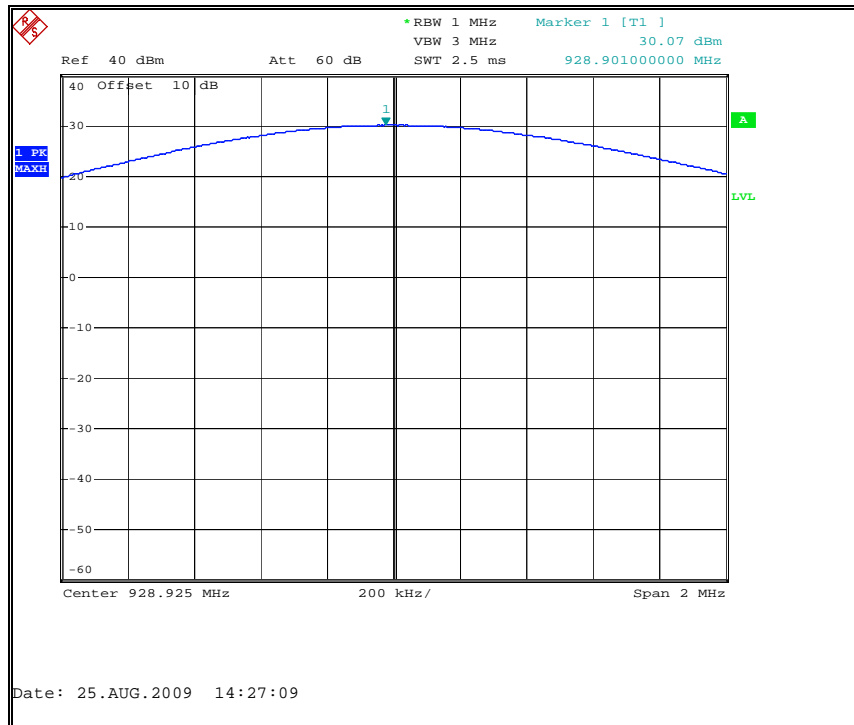

Figure 7.1.2-5: Peak Output Power 928.925 MHz

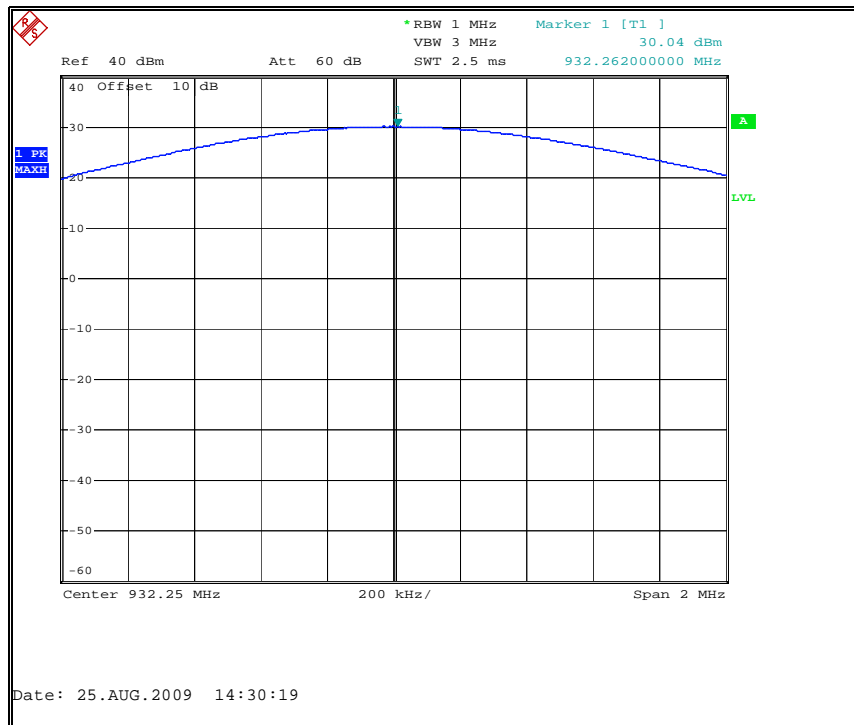

Figure 7.1.2-6: Peak Output Power 932.25 MHz

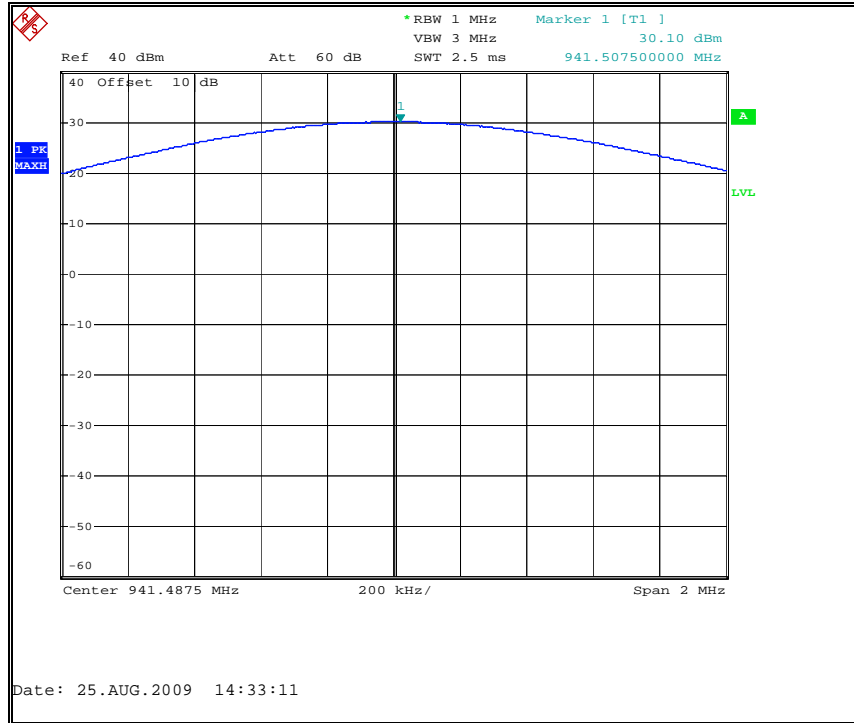

Figure 7.1.2-7: Peak Output Power 941.4875 MHz

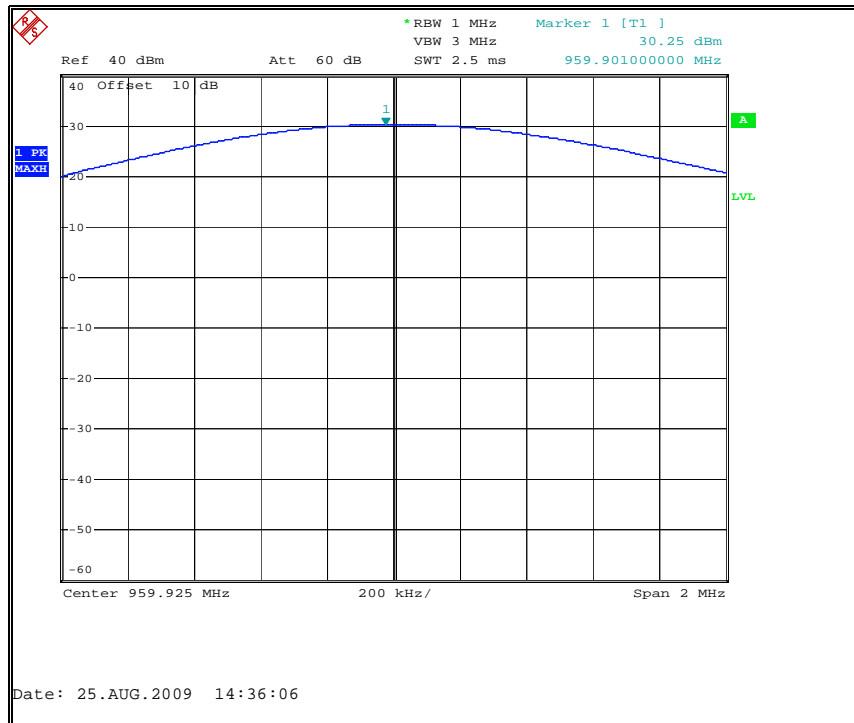

Figure 7.1.2-8: Peak Output Power 959.925 MHz

7.2 Occupied Bandwidth (Emission Limits)

7.2.1 Measurement Procedure

The RF output of the equipment under test was directly connected to the input of the Spectrum Analyzer through a 20 dB passive attenuator. The spectrum analyzer resolution and video bandwidths were set to 300 Hz and 300 Hz respectively. The internal correction factors of the spectrum analyzer were employed to correct for any cable or attenuator losses. Results of the test are shown below for all modes of operation.

7.2.2 Measurement Results

Part 24.133 a(1), a(2), IC RSS-134 6.3(i), (ii)

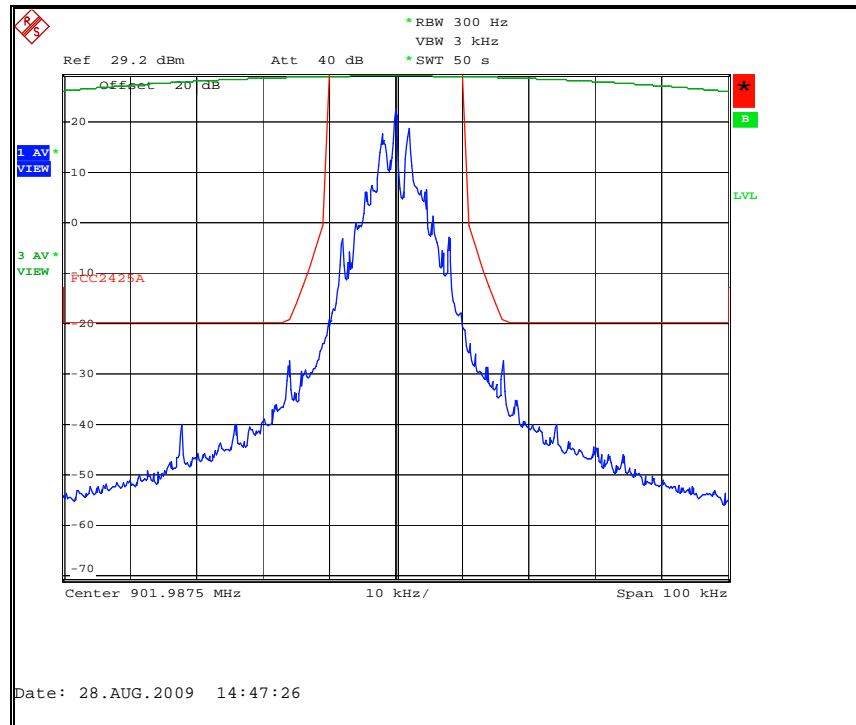

Figure 7.2.2-1: Normal Mode – 901.9875 MHz – 25 kHz Channel

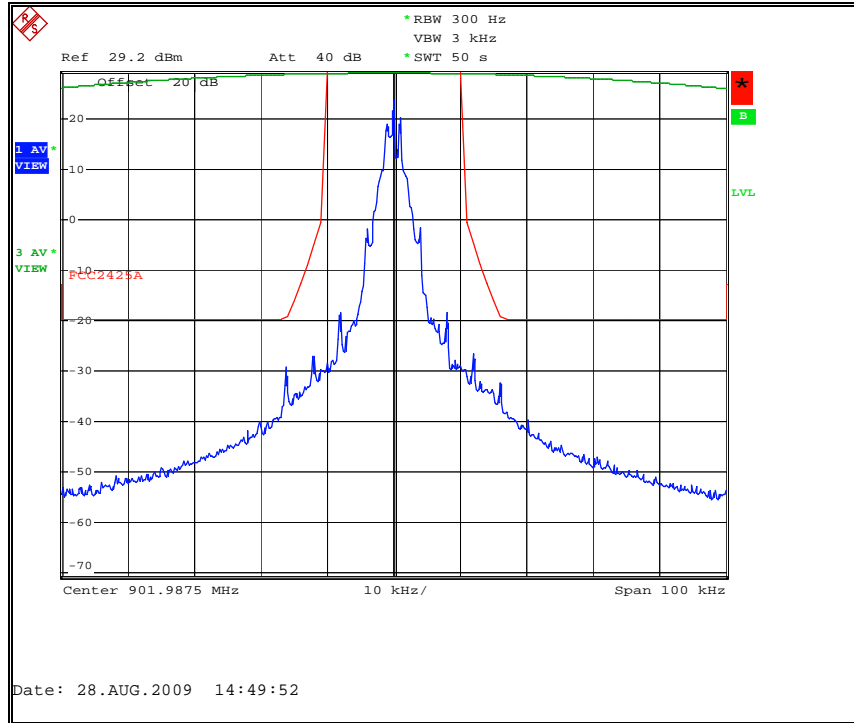

Figure 7.2.2-2: C&I Mode – 901.9875 MHz – 25 kHz Channel

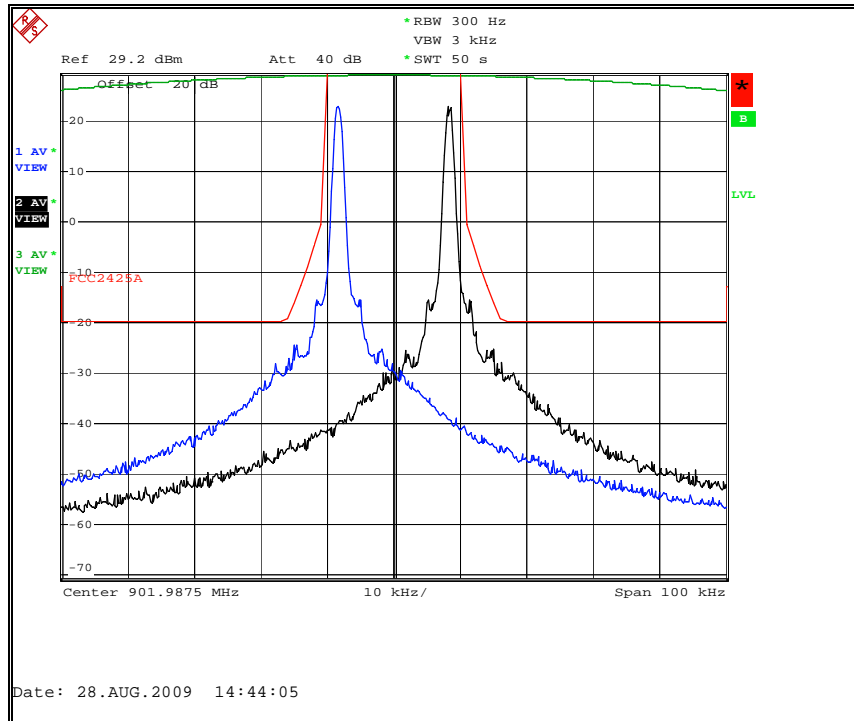

Figure 7.2.2-3: Boost Mode – 901.9875 MHz – 25 kHz Channel
Offset Channel of +/- 14 (+/- 8400 Hz)

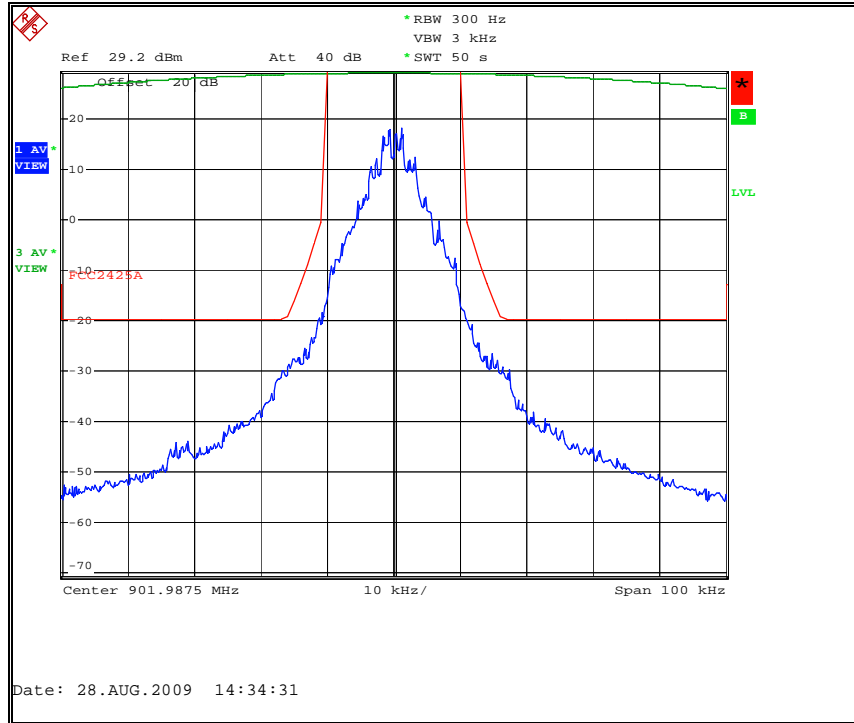

Figure 7.2.2-4: Double Density Mode – 901.9875 MHz – 25 kHz Channel

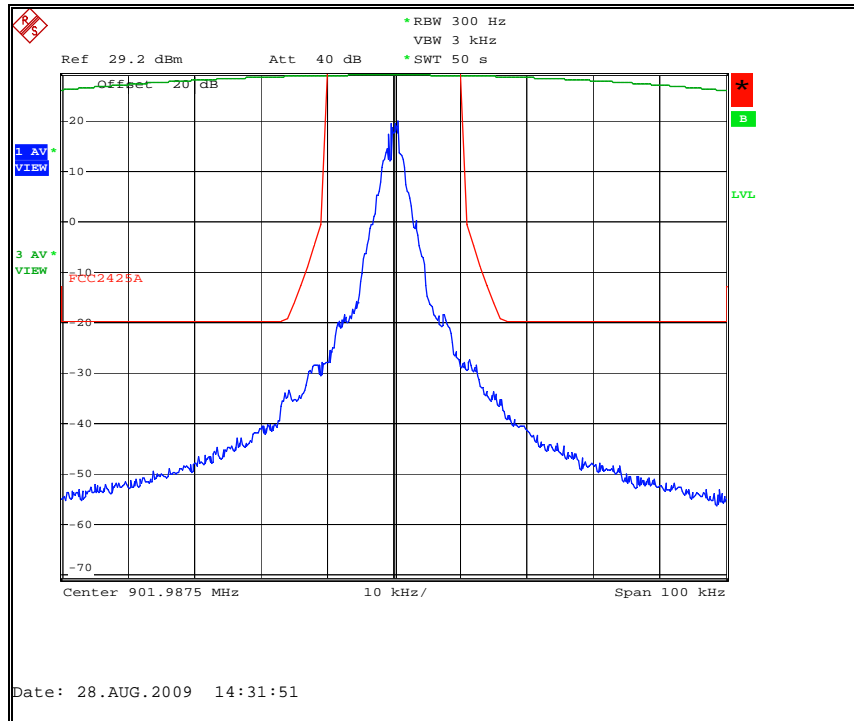

Figure 7.2.2-5: Priority Mode – 901.9875 MHz – 25 kHz Channel

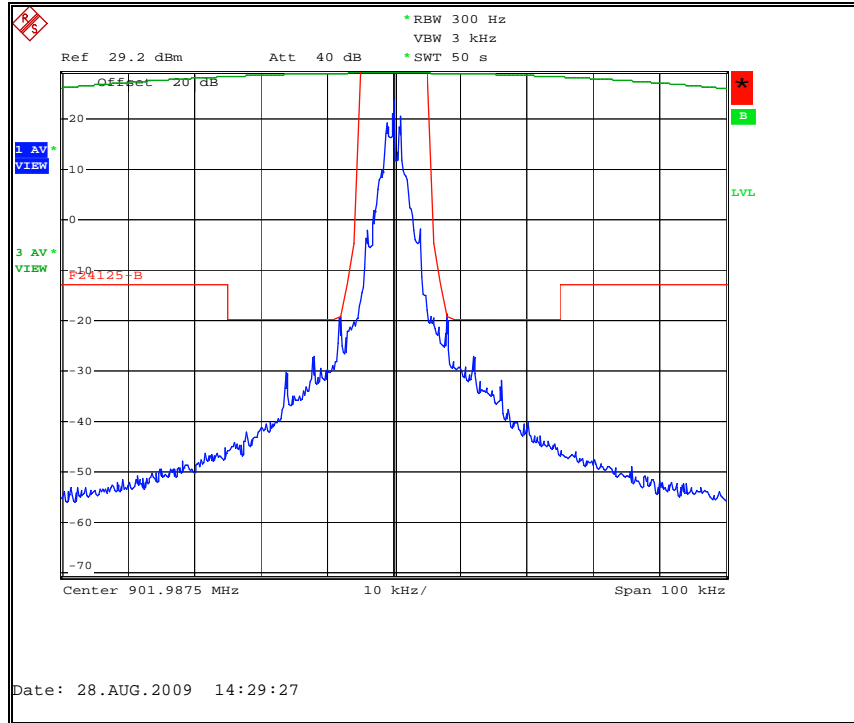

Figure 7.2.2-6: C&I Mode – 901.9875 MHz – 12.5 kHz Channel

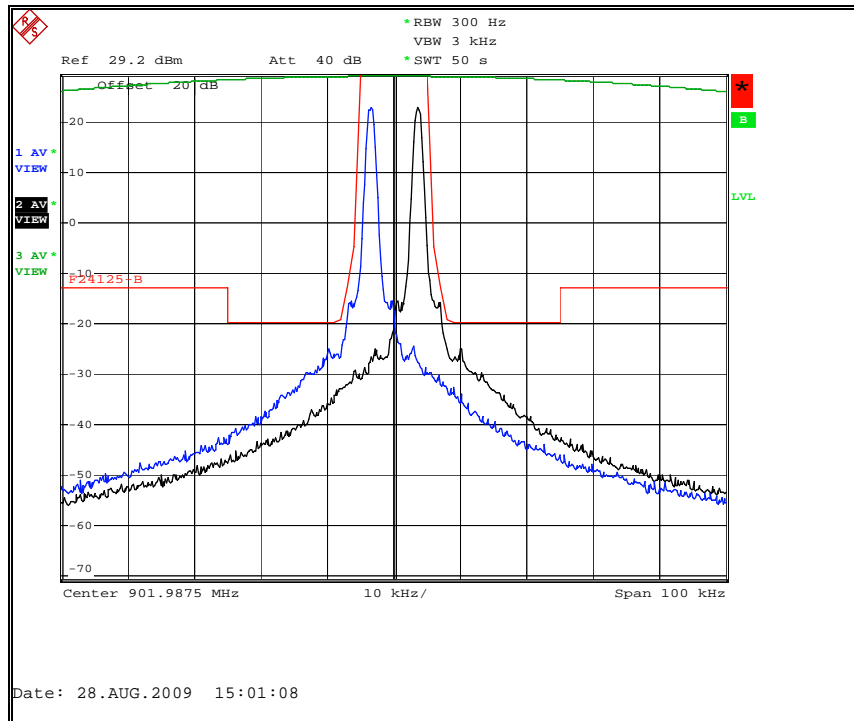

Figure 7.2.2-7: Boost Mode – 901.9875 MHz – 12.5 kHz Channel
Offset Channel of +/- 6 (+/- 3600 Hz)

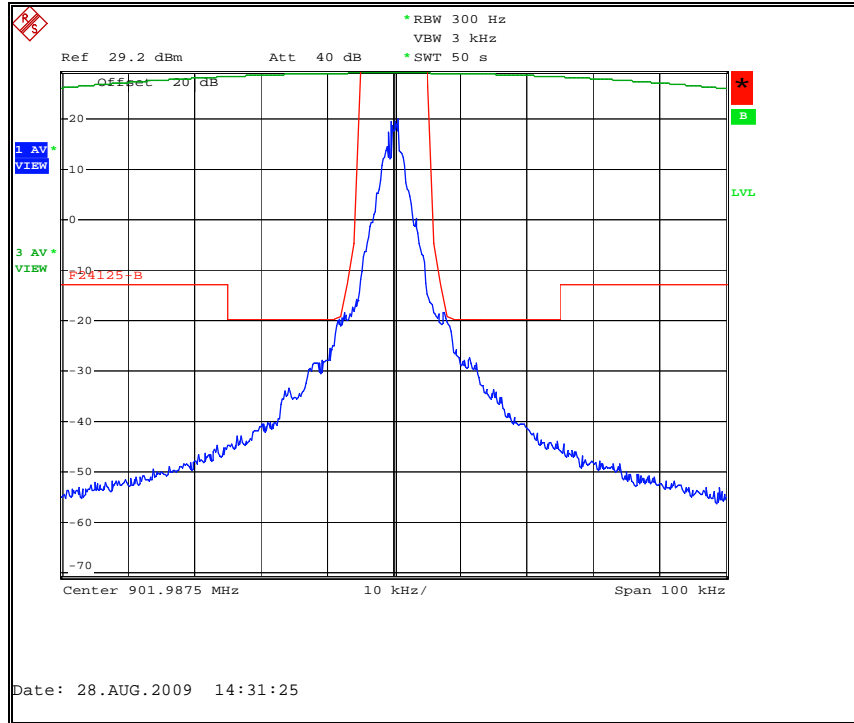

Figure 7.2.2-8: Priority Mode – 901.9875 MHz – 12.5 kHz Channel

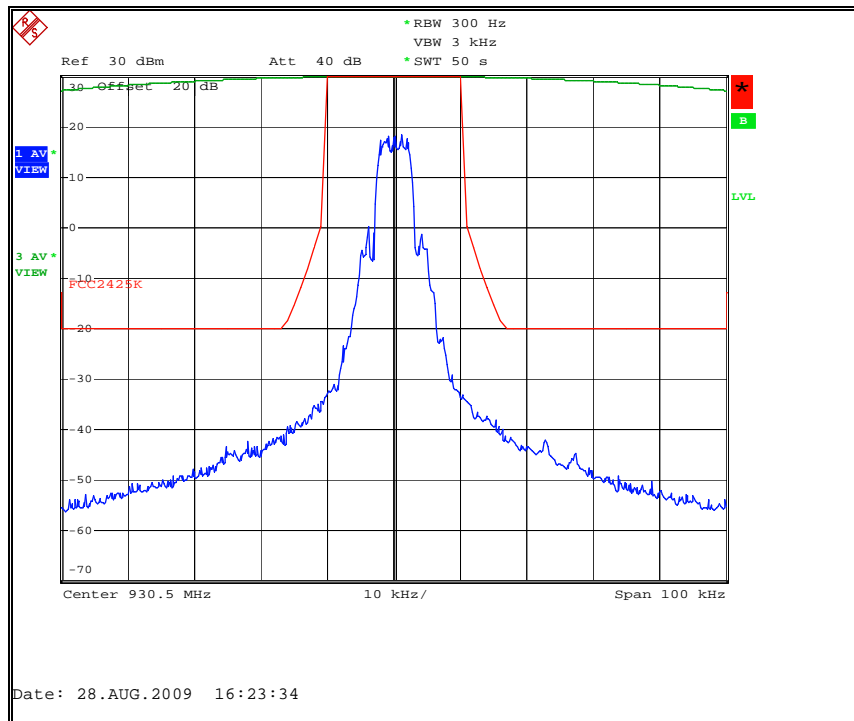

Figure 7.2.2-9: MPass Mode (5k) – 930.5 MHz – 25 kHz Channel

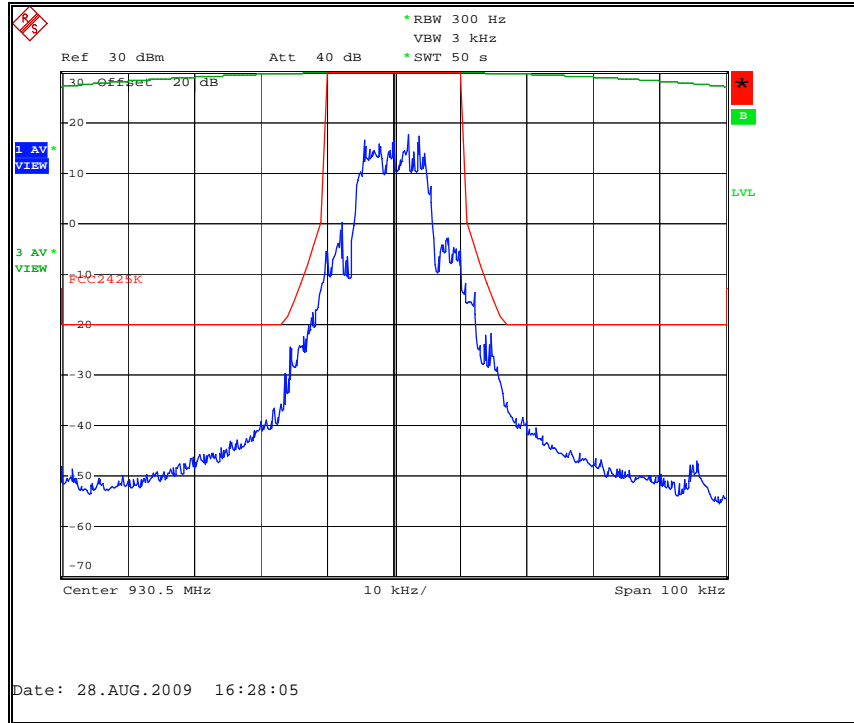

Figure 7.2.2-10: MPass Mode (10k) – 930.5 MHz – 25 kHz Channel

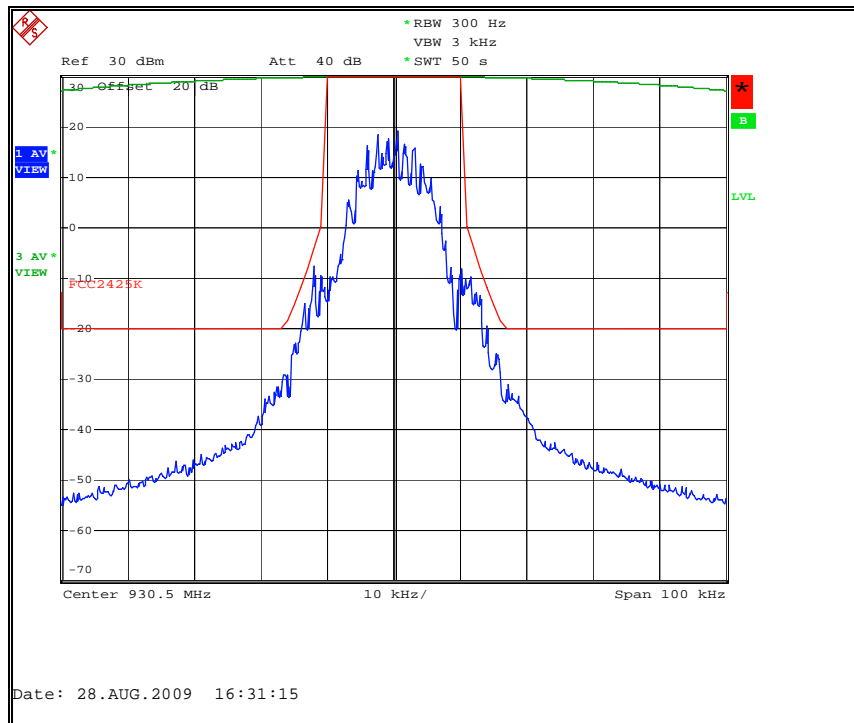

Figure 7.2.2-11: MPass Mode (12.5k) – 930.5 MHz – 25 kHz Channel

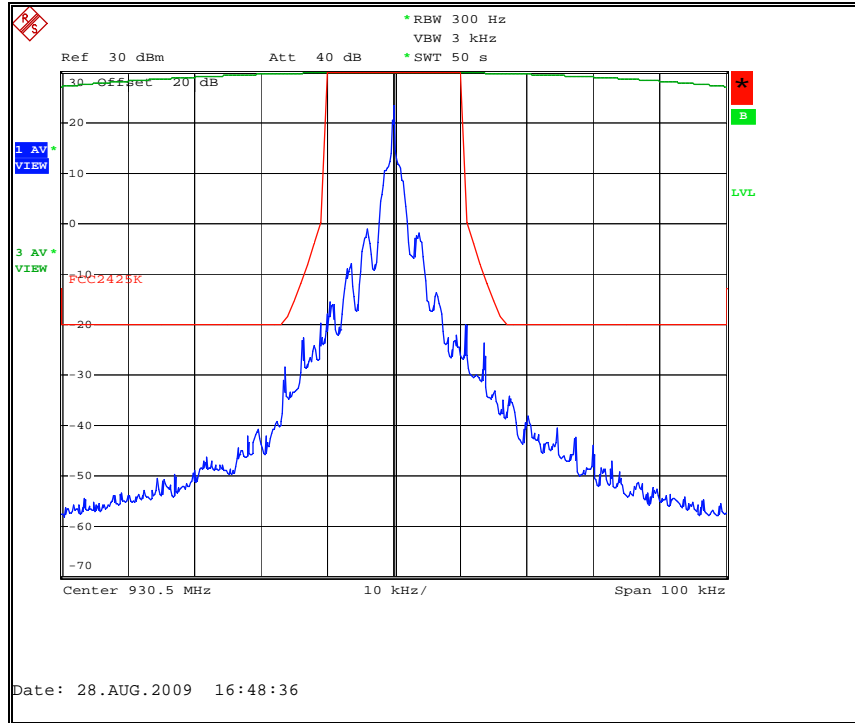

Figure 7.2.2-12: Amplitude Shift Keying Mode (ASK) – 930.5 MHz

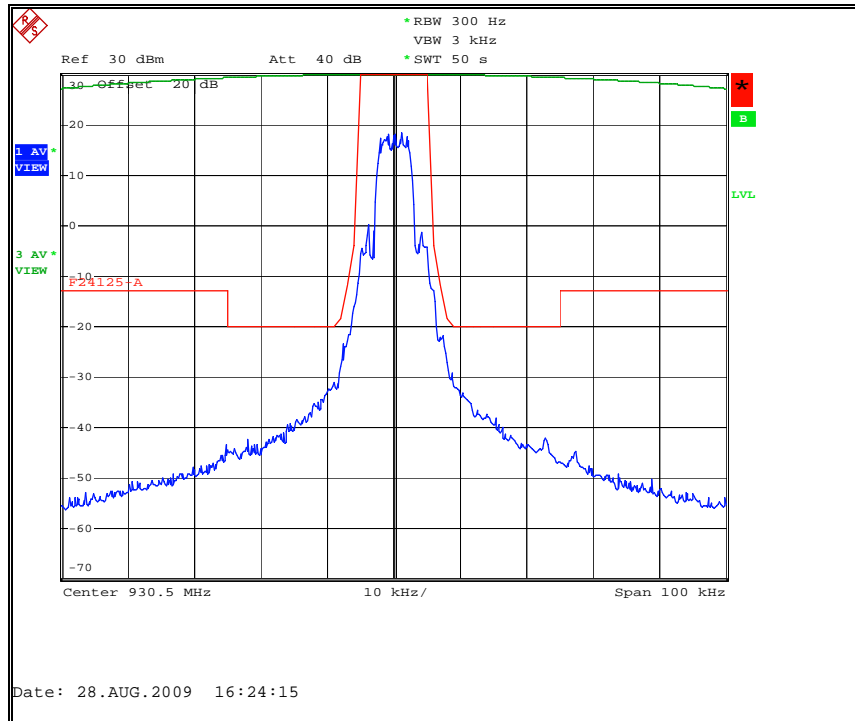

Figure 7.2.2-13: MPass Mode (5K)– 930.5 MHz – 12.5 kHz Channel

Part 90.210 (j), RSS-119 5.8.8

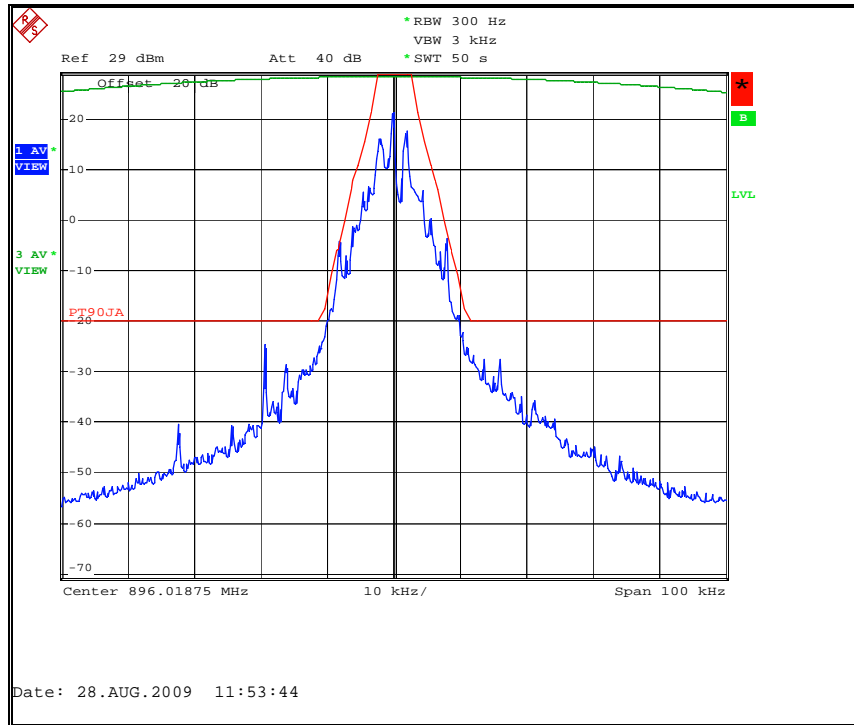

Figure 7.2.2-14: Normal Mode – 896.01875 MHz

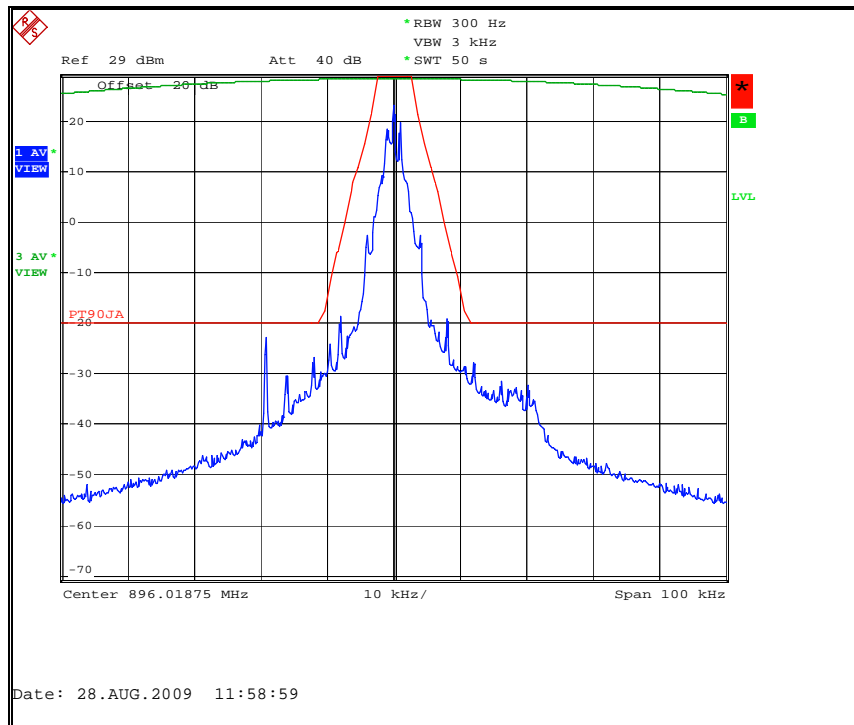

Figure 7.2.2-15: C&I Mode – 896.01875 MHz

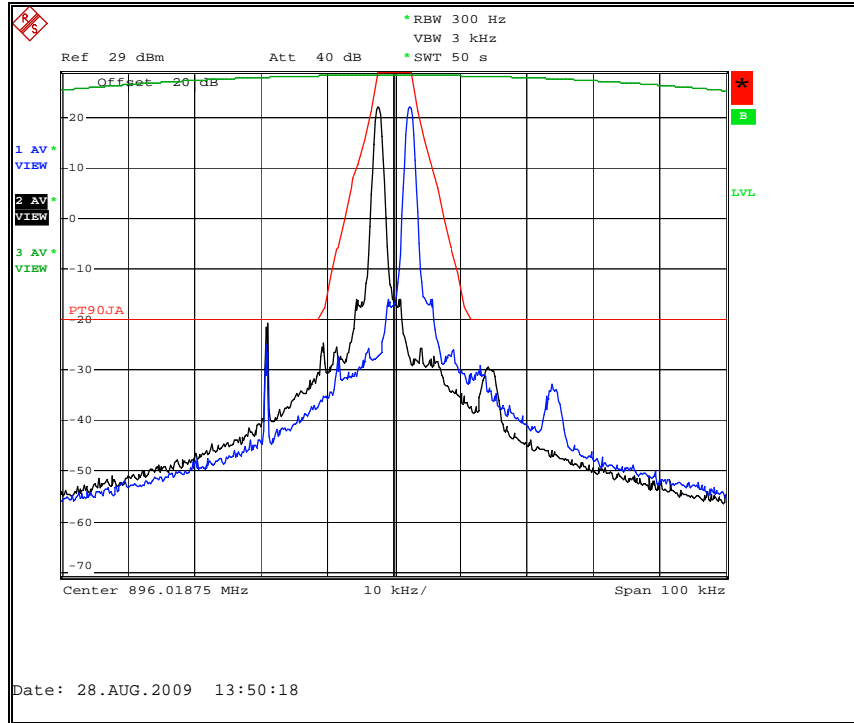

Figure 7.2.2-16: Boost Mode – 896.01875 MHz
Offset Channel of +/- 4 (+/- 2400 Hz)

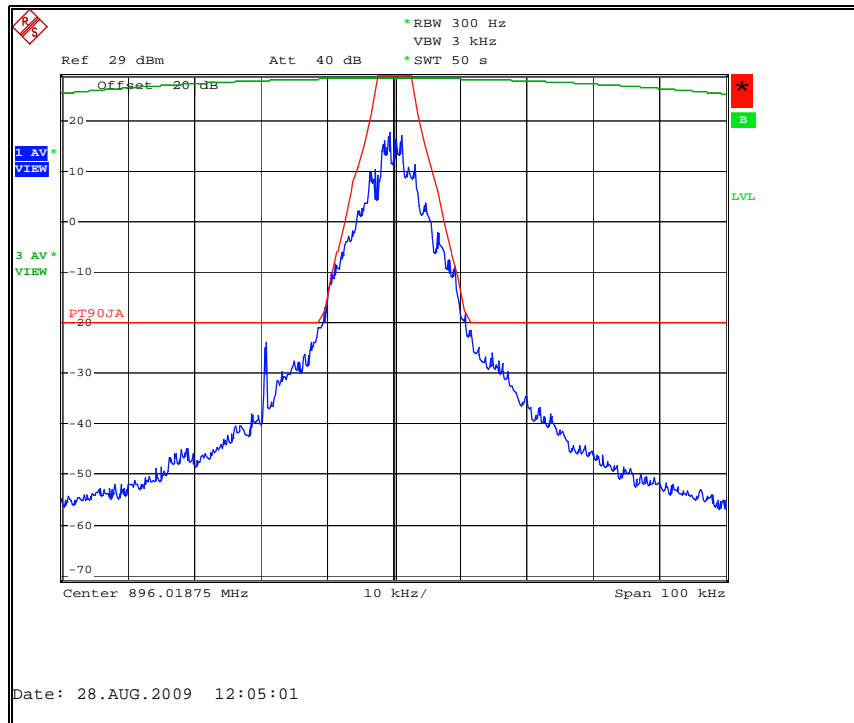

Figure 7.2.2-17: Double Density Mode – 896.01875 MHz

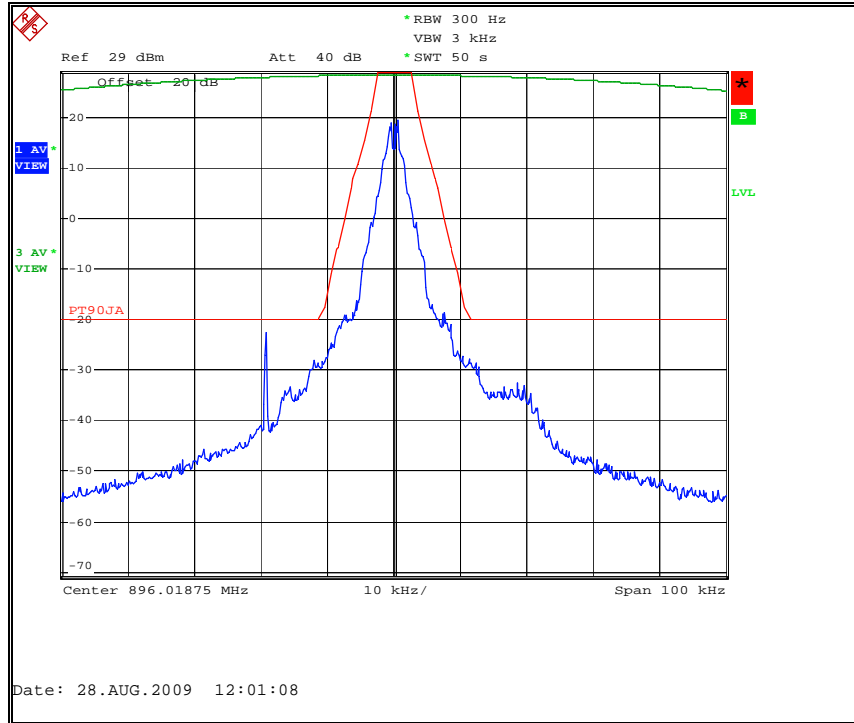

Figure 7.2.2-18: Priority Mode – 896.01875 MHz

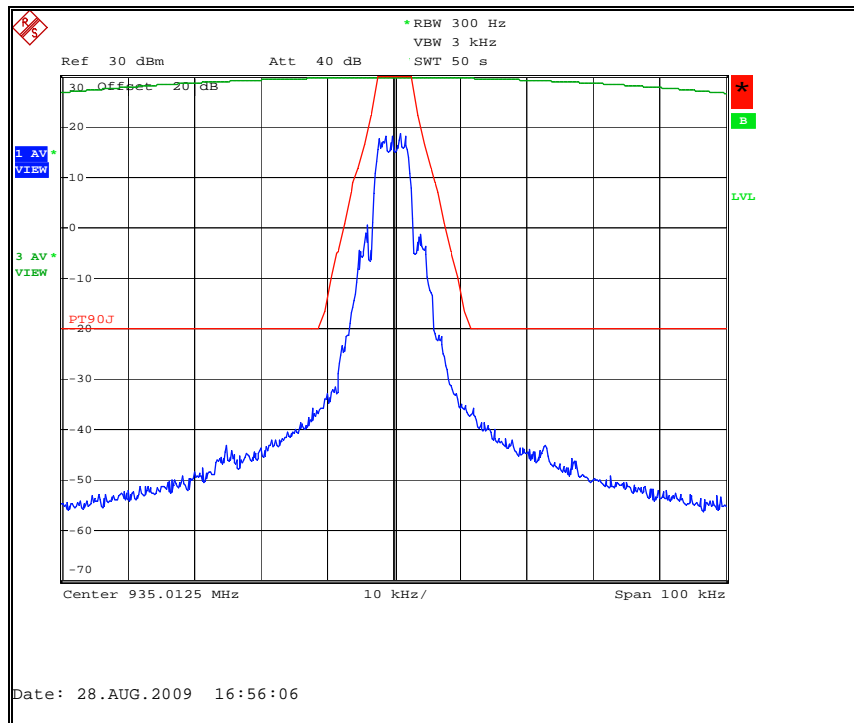

Figure 7.2.2-19: MPass Mode (5k) – 935.0125 MHz

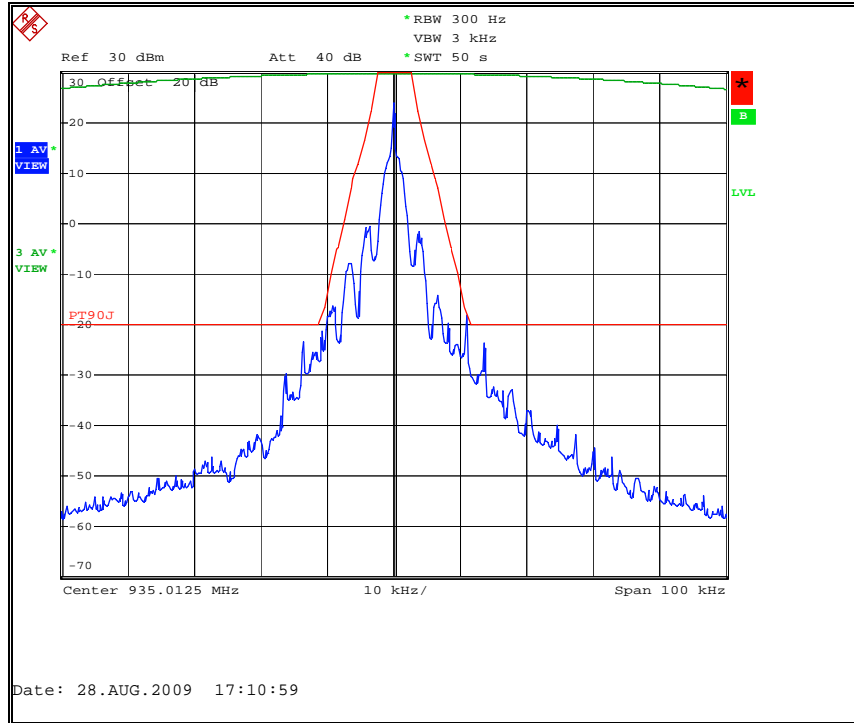

Figure 7.2.2-20: Amplitude Shift Keying Mode (ASK)– 935.0125 MHz

Part 101.111 a(6), RSS-119 5.8.6*

* FCC Part 101.111a(6) provides worst case

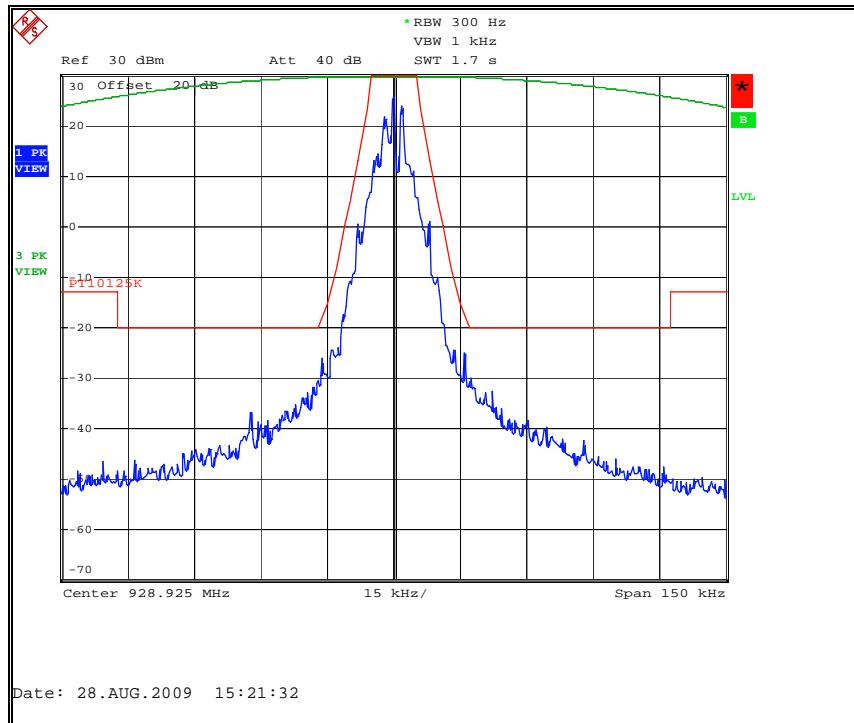

Figure 7.2.2-21: Normal Mode – 928.925 MHz

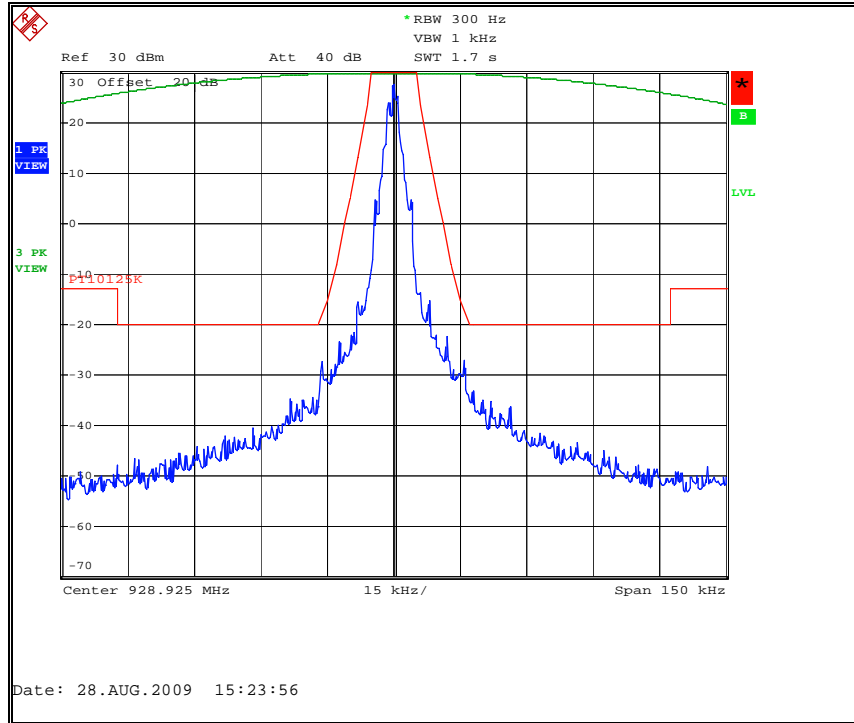

Figure 7.2.2-22: C&I Mode – 928.925 MHz

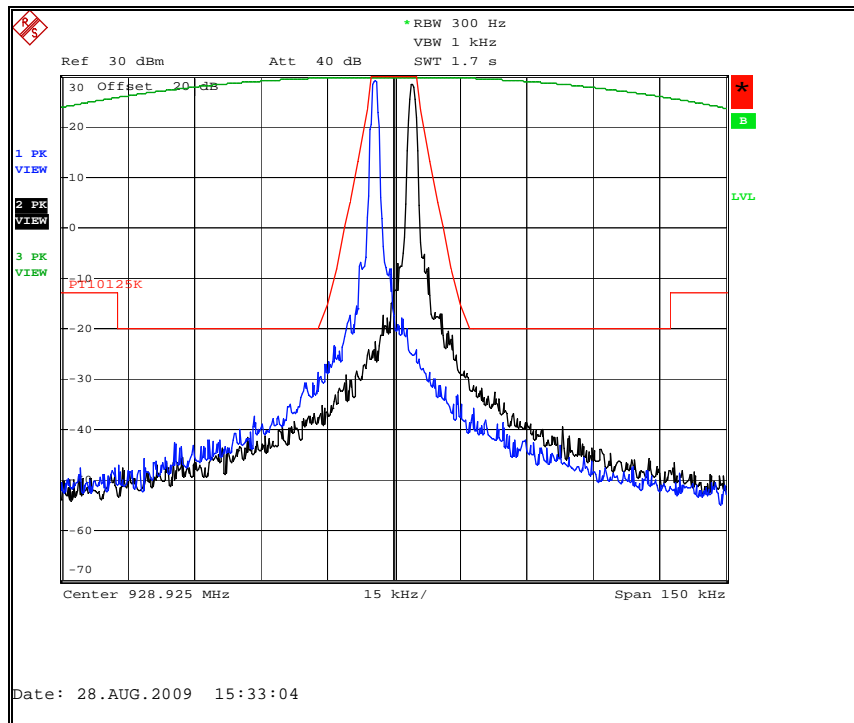

Figure 7.2.2-23: Boost Mode – 928.925 MHz
Offset Channel of +/- 7 (+/- 4200 Hz)

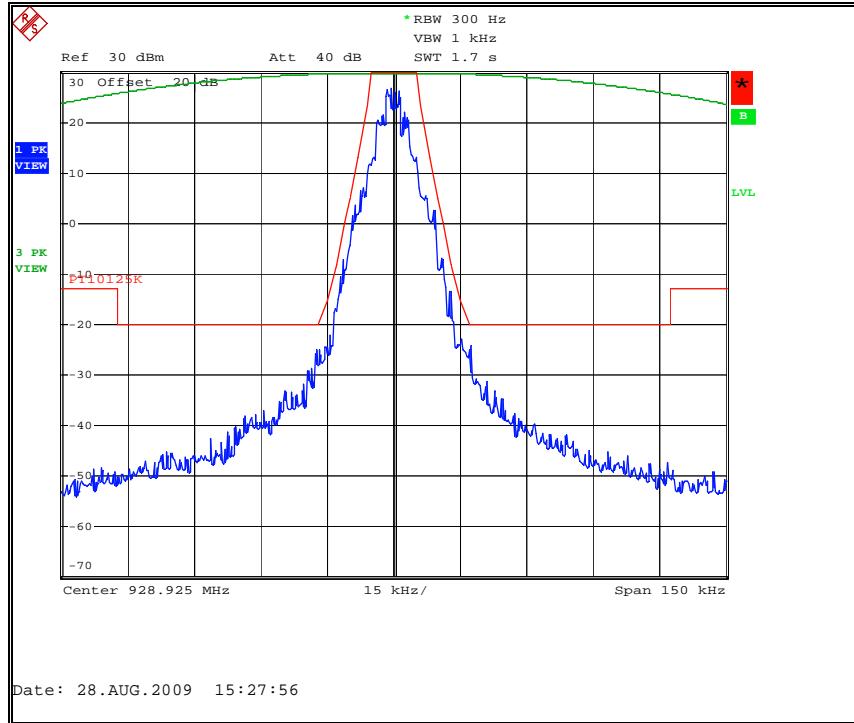

Figure 7.2.2-24: Double Density Mode – 928.925 MHz

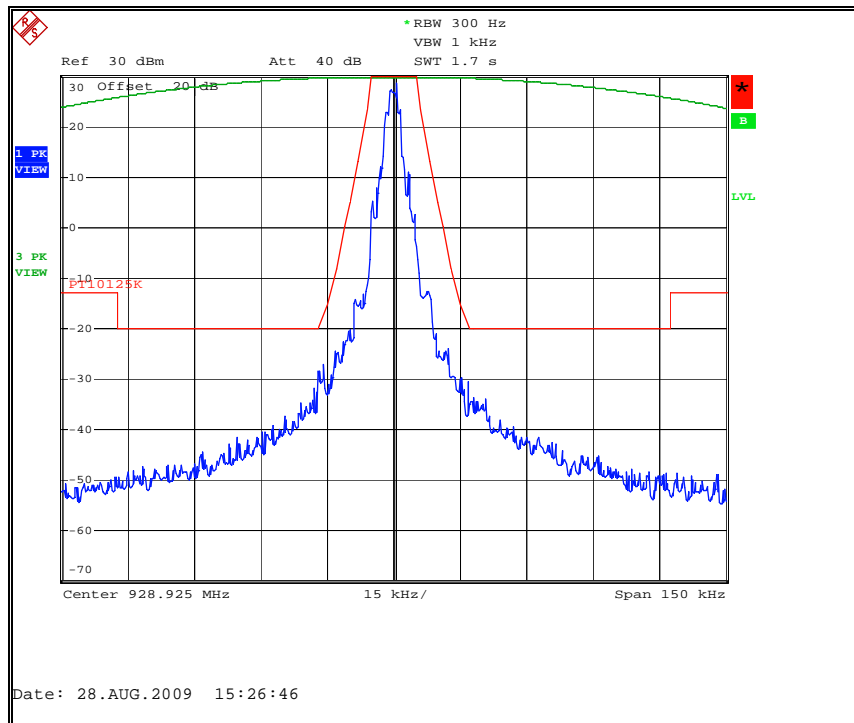

Figure 7.2.2-25: Priority Mode – 928.925 MHz

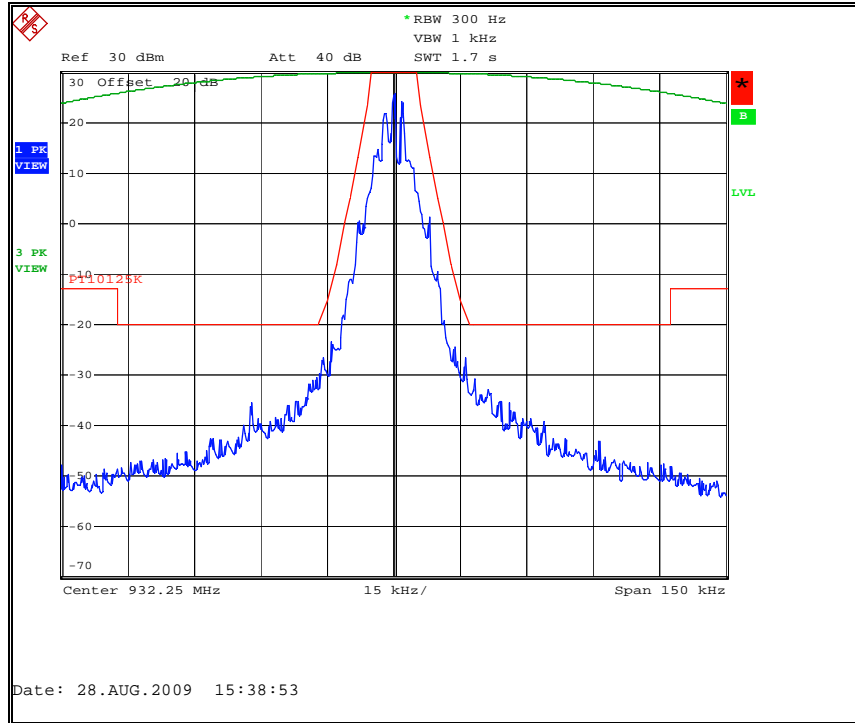

Figure 7.2.2-26: Normal Mode – 932.25 MHz

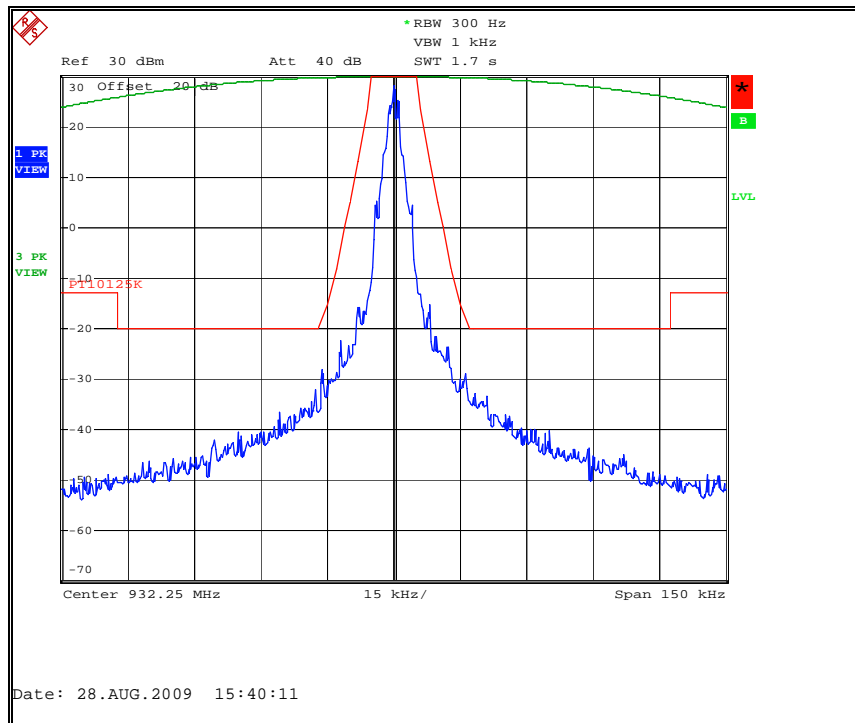

Figure 7.2.2-27: C&I Mode – 932.25 MHz

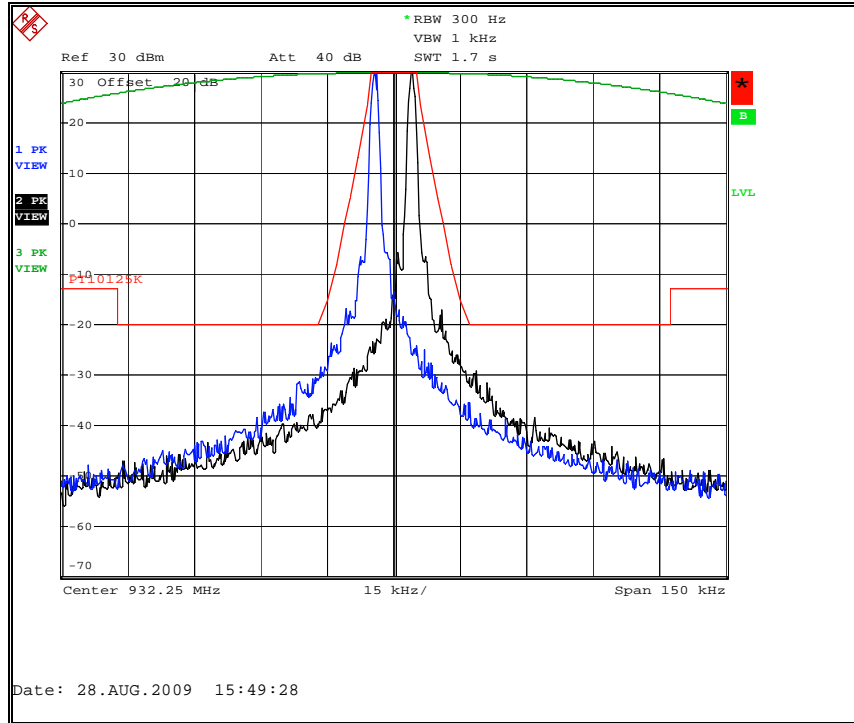

Figure 7.2.2-28: Boost Mode – 932.25 MHz
Offset Channel of +/- 7 (+/- 4200 Hz)

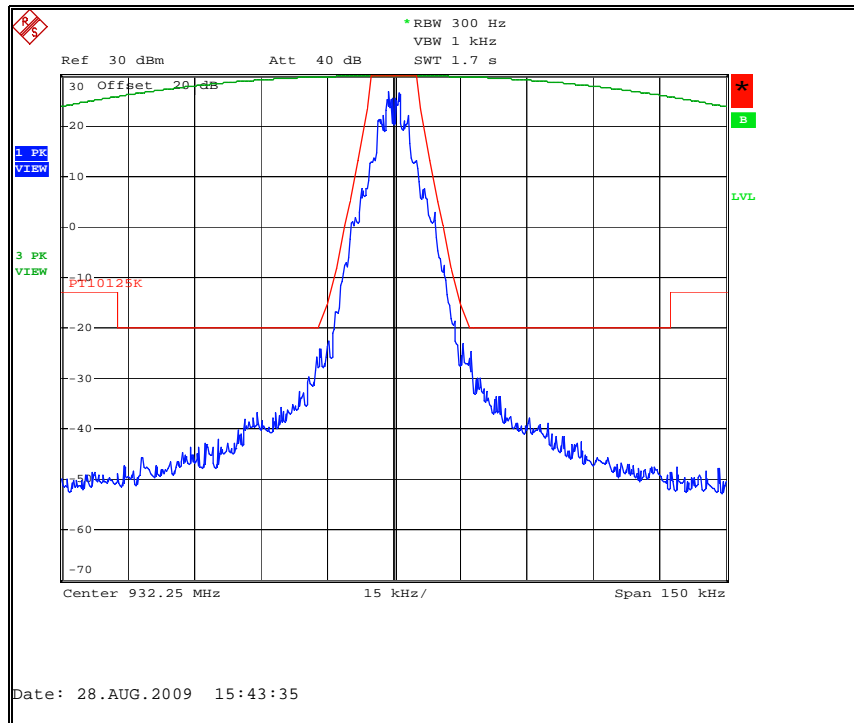

Figure 7.2.2-29: Double Density Mode – 932.25 MHz

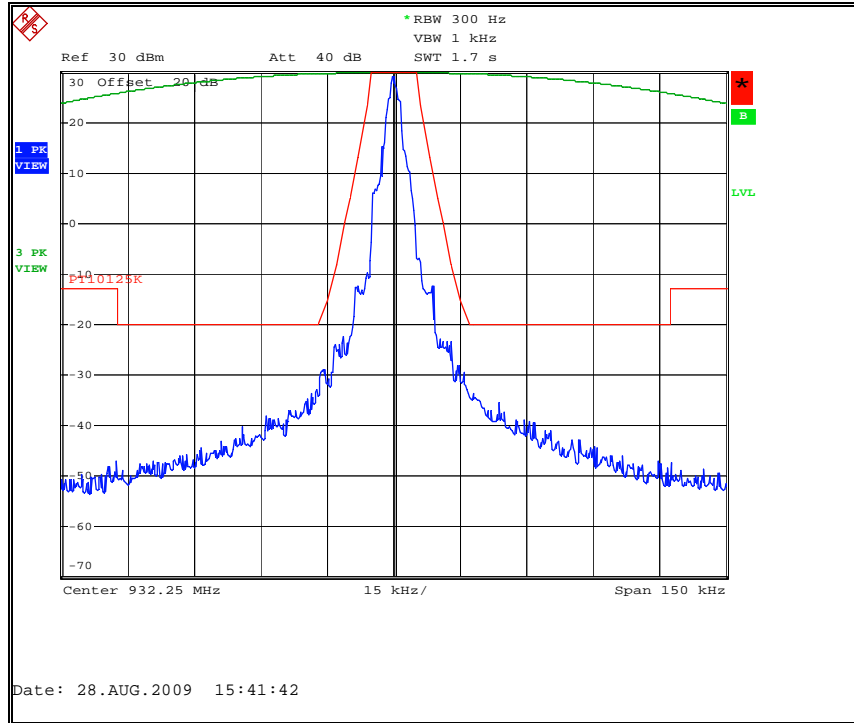

Figure 7.2.2-30: Priority Mode – 932.25 MHz

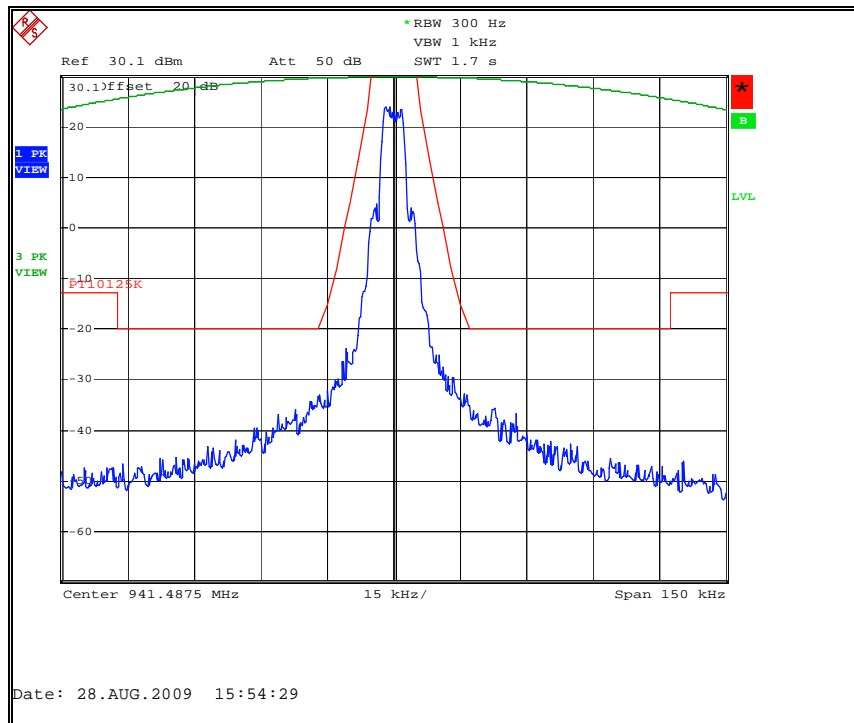

Figure 7.2.2-31: MPass Mode (5k) – 941.4875 MHz

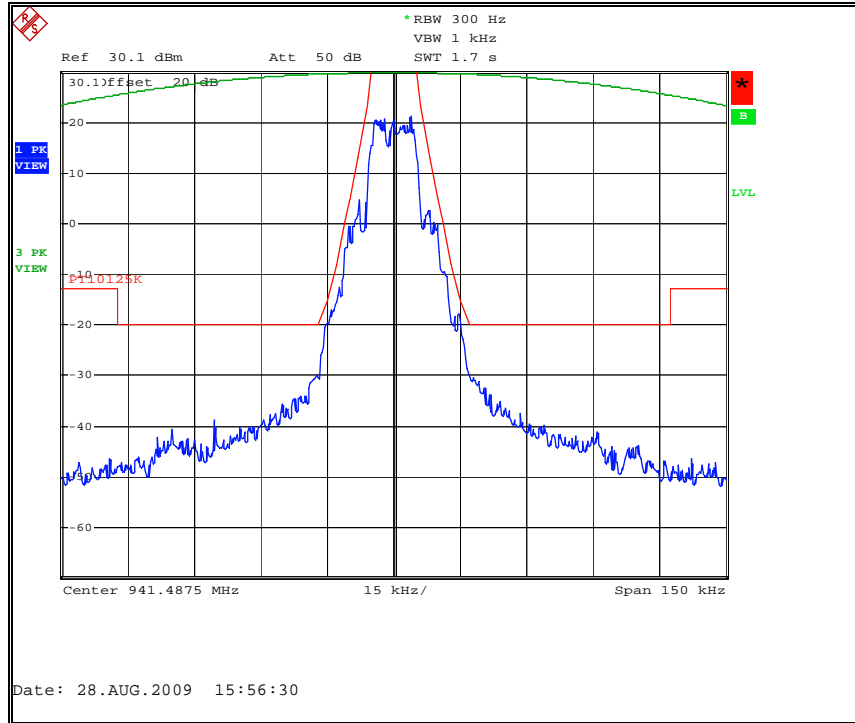

Figure 7.2.2-32: MPass Mode (10k) – 941.4875 MHz

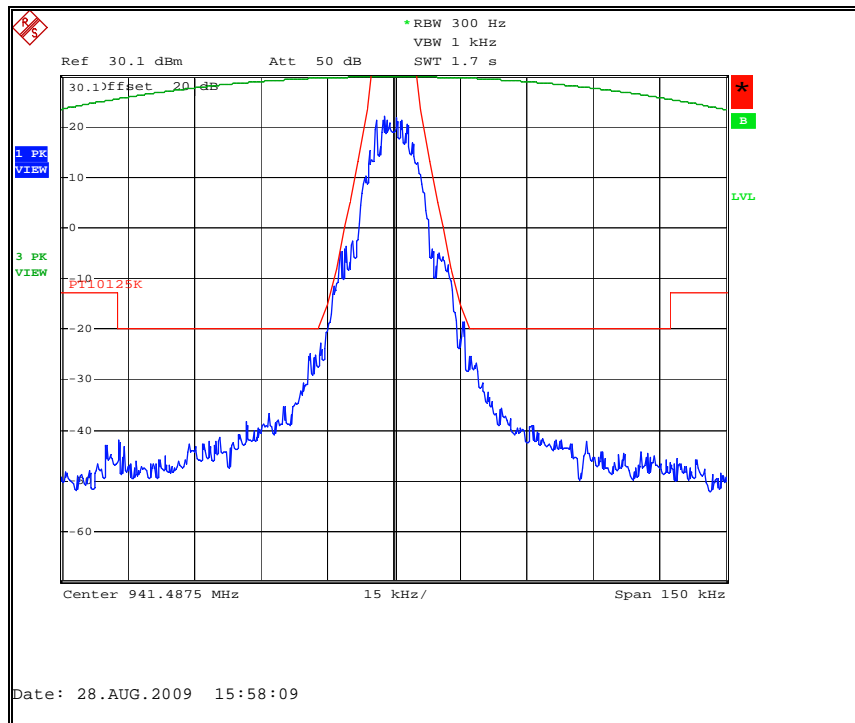

Figure 7.2.2-33: MPass Mode (12.5k) – 941.4875 MHz

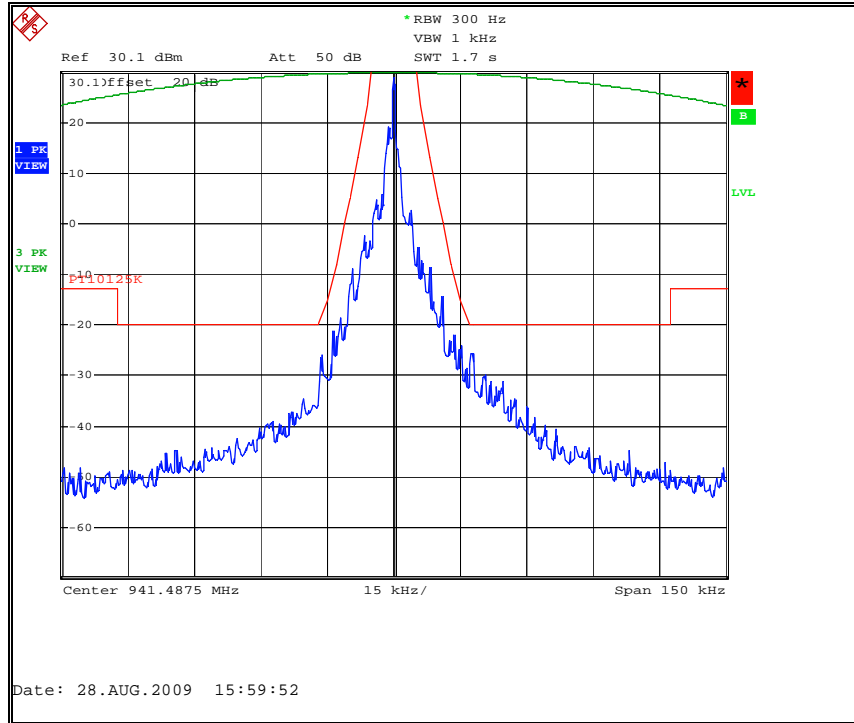

Figure 7.2.2-34: Amplitude Shift Keying Mode (ASK)– 941.4875 MHz

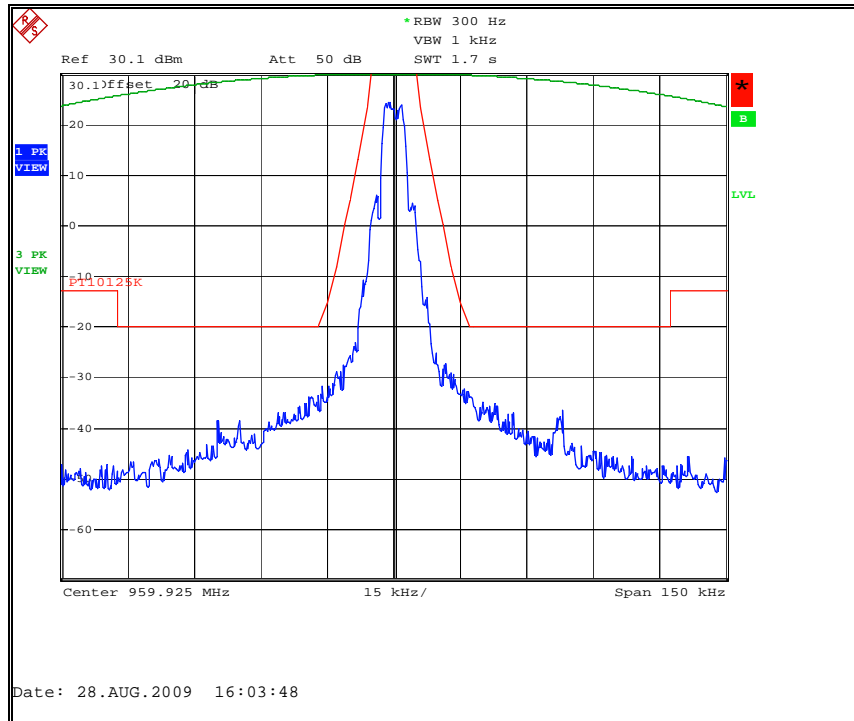

Figure 7.2.2-35: MPass Mode (5k) – 959.925 MHz

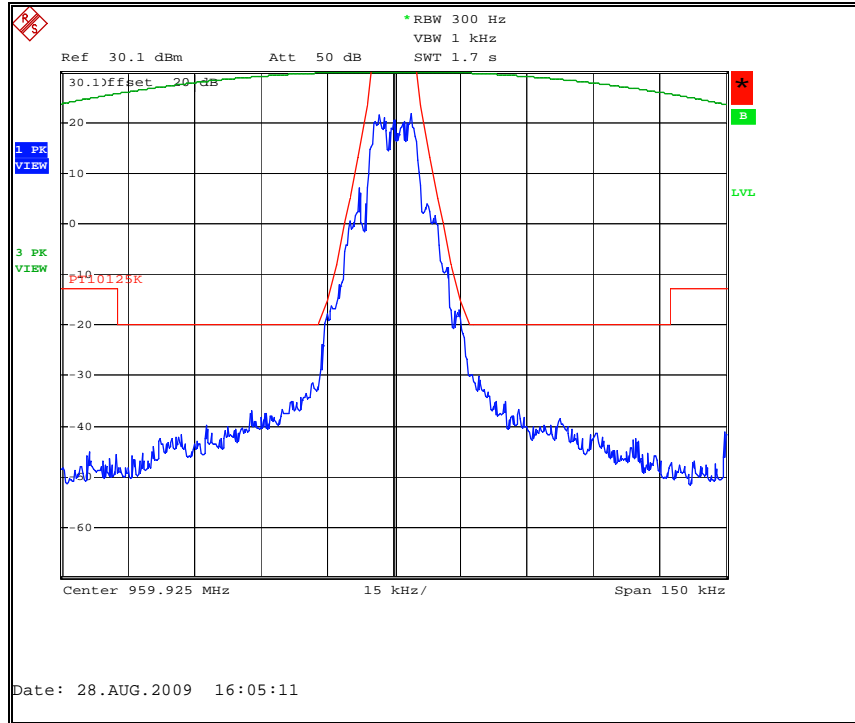

Figure 7.2.2-36: MPass Mode (10k) – 959.925 MHz

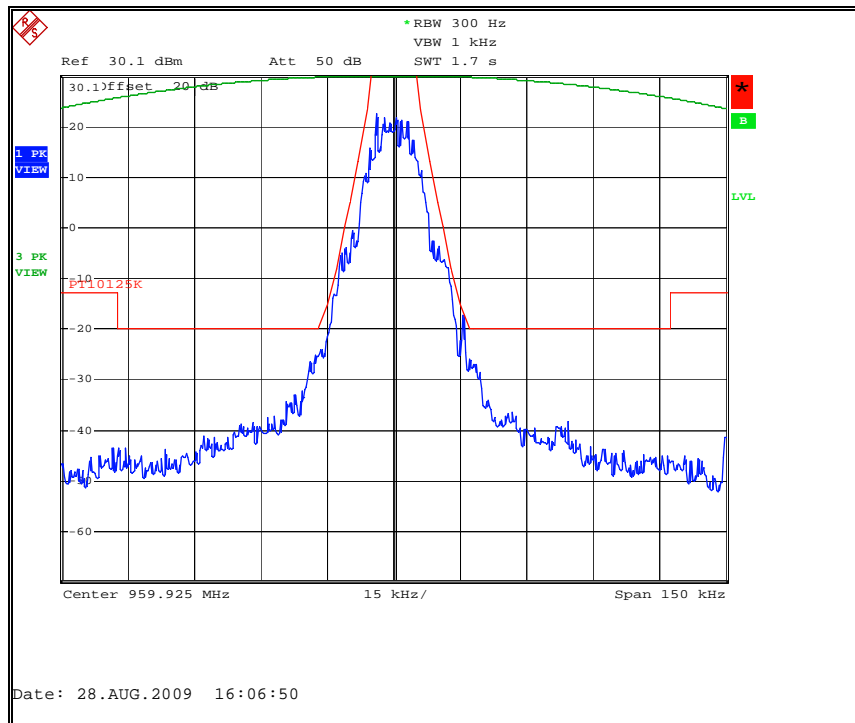

Figure 7.2.2-37: MPass Mode (12.5k) – 959.925 MHz

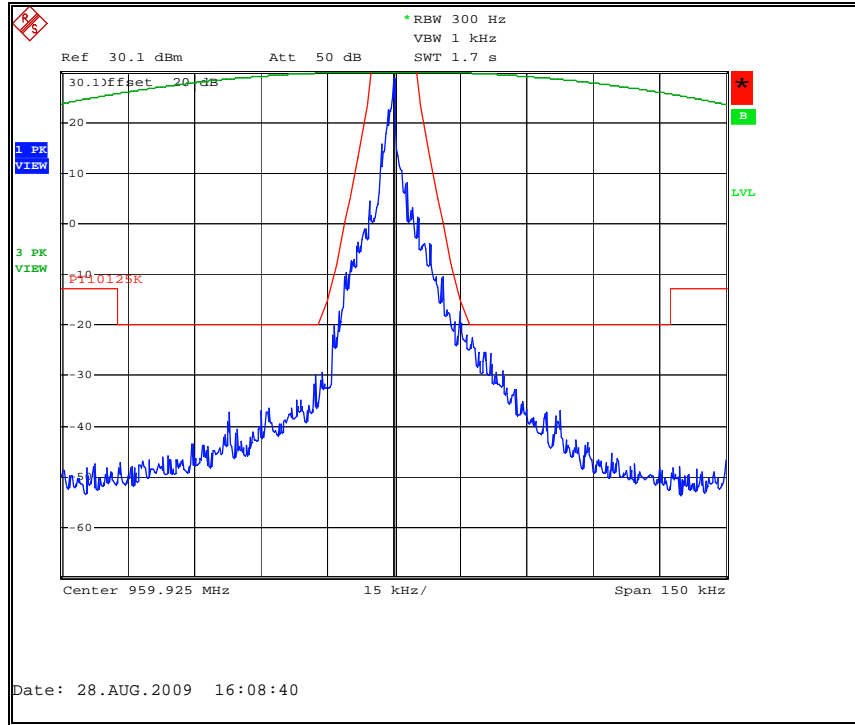

Figure 7.2.2-38: Amplitude Shift Keying Mode (ASK)– 959.925 MHz

7.3 Spurious Emissions at Antenna Terminals

7.3.1 Measurement Procedure

The RF output of the equipment under test was directly connected to the input of the Spectrum Analyzer through a 20 dB passive attenuator for measurements below 1000 MHz. A high pass filter was used for measurements above 1000 MHz. The spectrum analyzer resolution bandwidth was set to 30 kHz below 1000 MHz and 1 MHz above 1000 MHz. The internal correction factors of the spectrum analyzer were employed to correct for any cable or attenuator losses. The spectrum was investigated in accordance to CFR 47 Part 2.1057.

The equipment under test was evaluated to multiple FCC rule parts with the most stringent limit applied to all measurements.

The EUT was evaluated for all modulation modes with the worst case presented in section 7.3.2 below.

7.3.2 Measurement Results

Part 24.133 a(1), a(2), IC RSS-134 6.3(i), (ii)

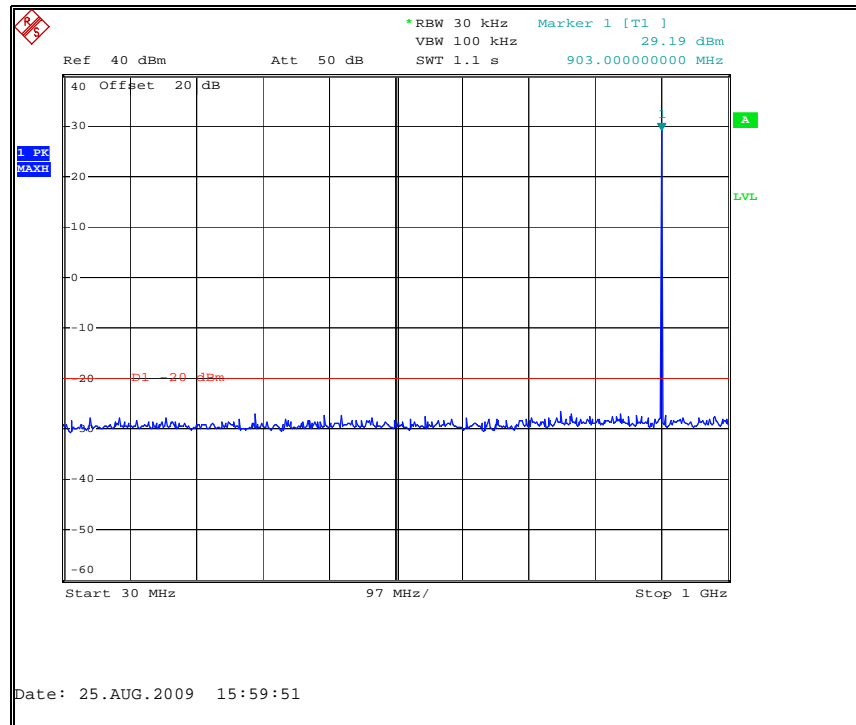

Figure 7.3.2-1: 901.9875 MHz – 30MHz to 1GHz

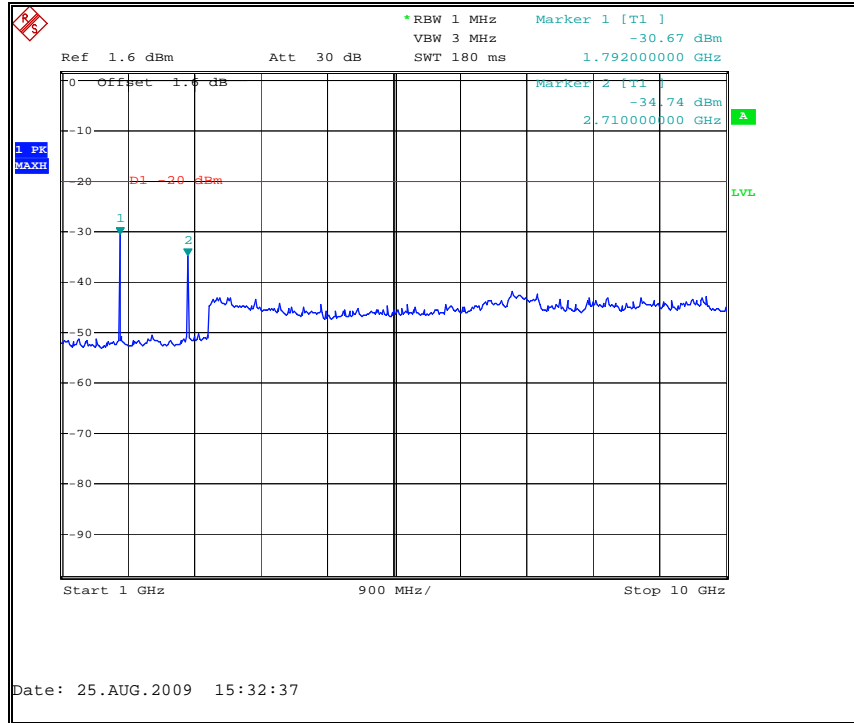

Figure 7.3.2-2: 901.9875 MHz – 1GHz to 10GHz

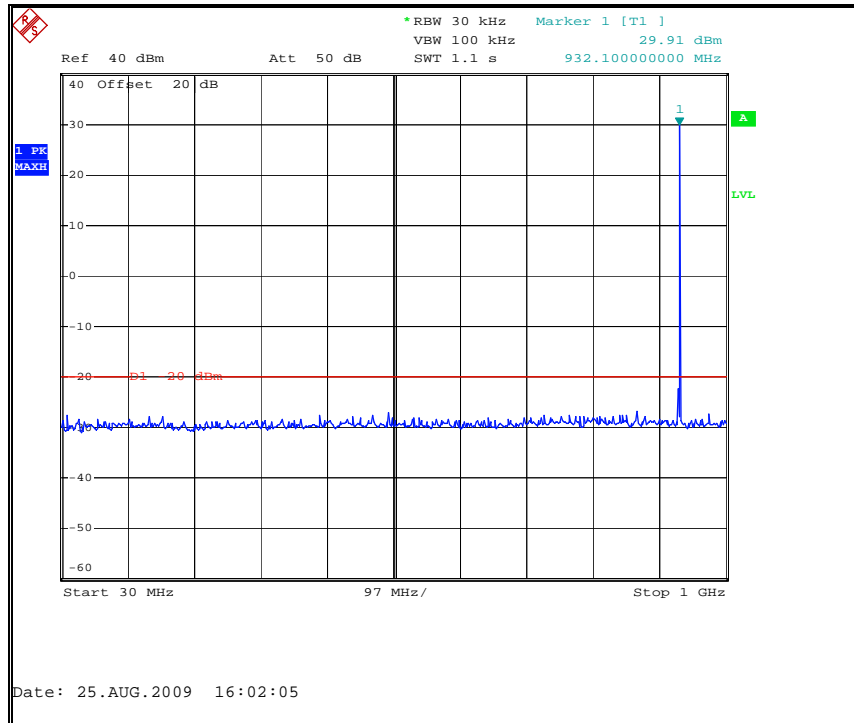

Figure 7.3.2-3: 930.5 MHz – 30MHz to 1GHz

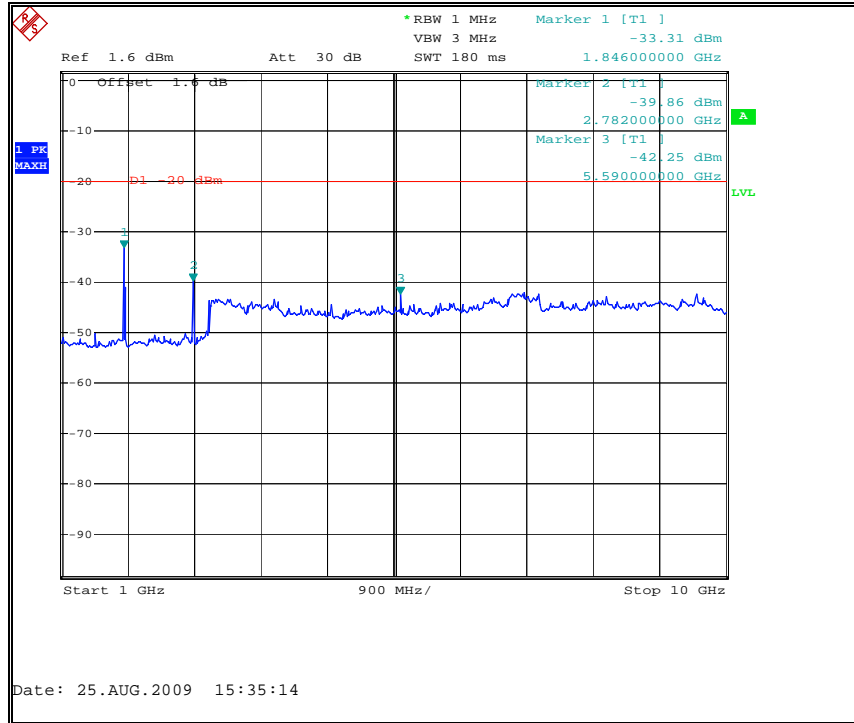

Figure 7.3.2-4: 930.5 MHz – 1GHz to 10GHz

Part 90.210 (j), RSS-119 5.8.8

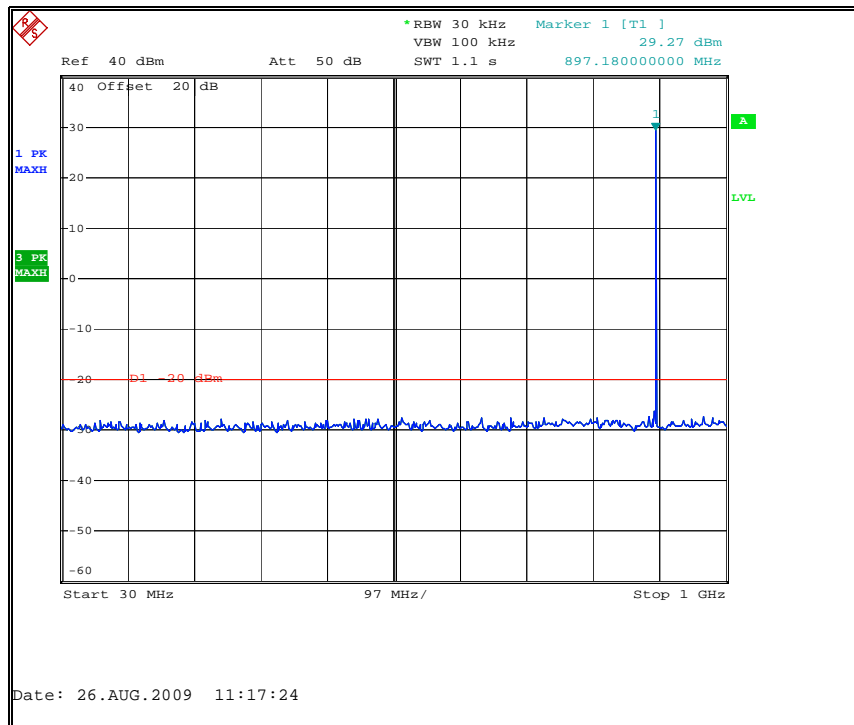

Figure 7.3.2-5: 896.0125 MHz – 30MHz to 1GHz

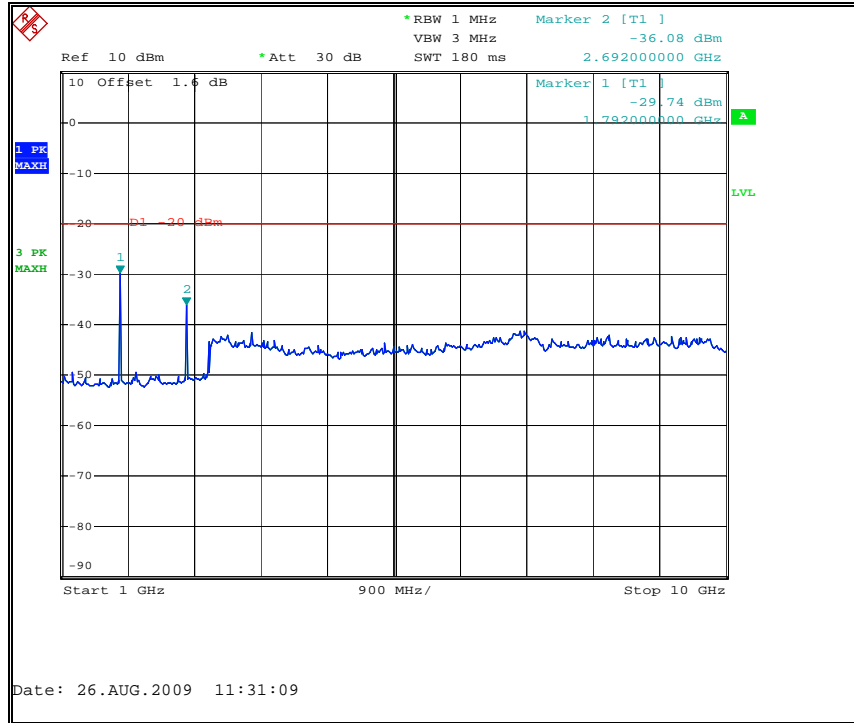

Figure 7.3.2-6: 896.0125 MHz – 1GHz to 10GHz

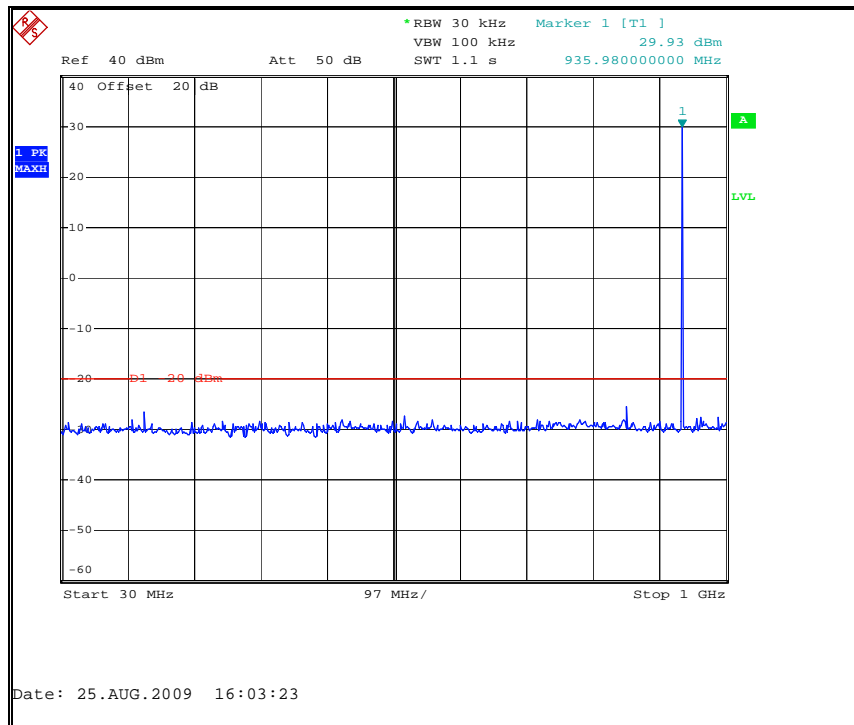

Figure 7.3.2-7: 935.0125 MHz – 30MHz to 1GHz

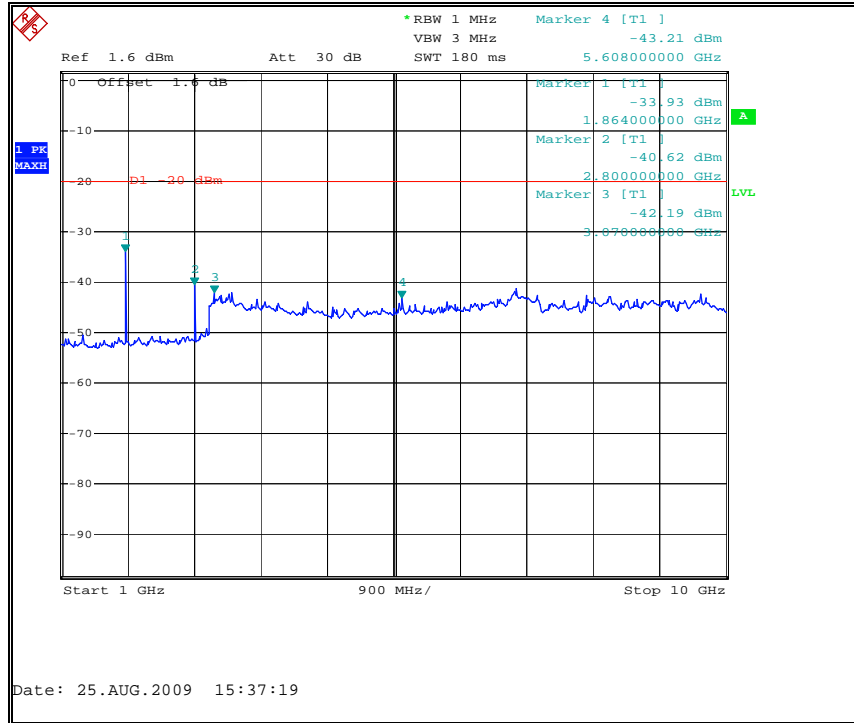

Figure 7.3.2-8: 935.0125 MHz – 1GHz to 10GHz

Part 101.111 a(6), RSS-119 5.8.6

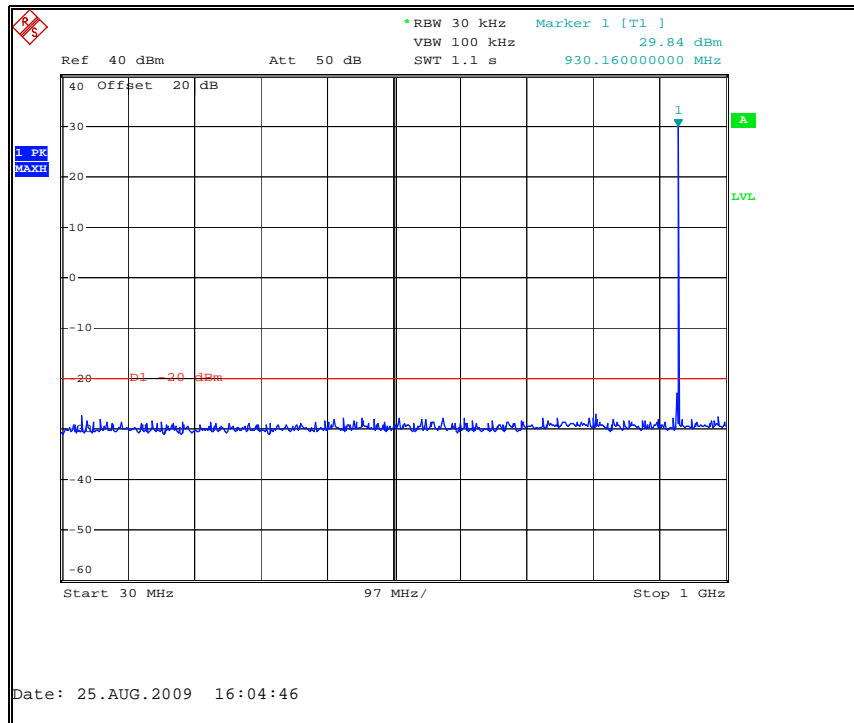

Figure 7.3.2-9: 928.925 MHz – 30MHz to 1GHz

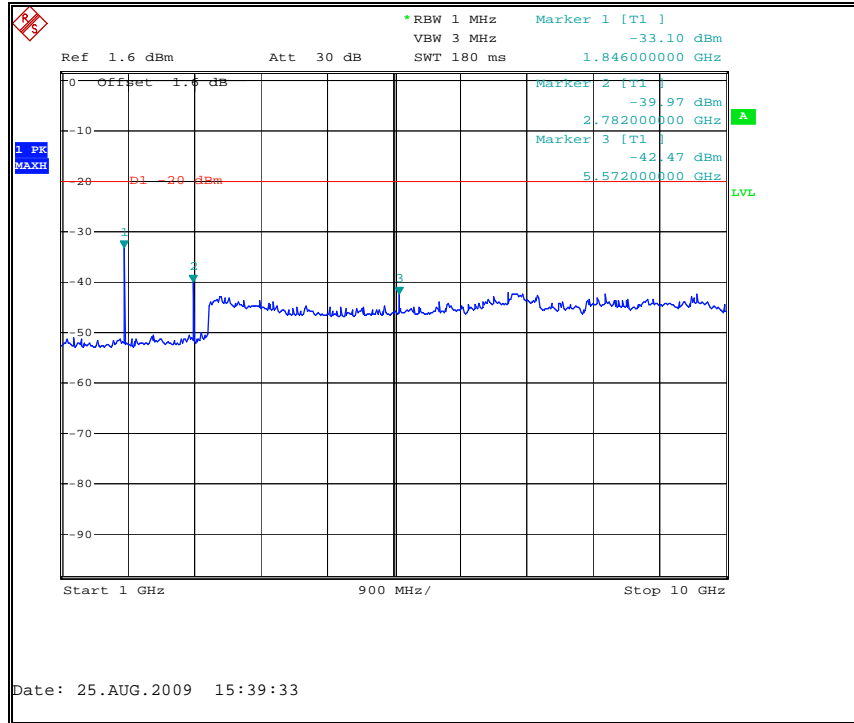

Figure 7.3.2-10: 928.925 MHz – 1GHz to 10GHz

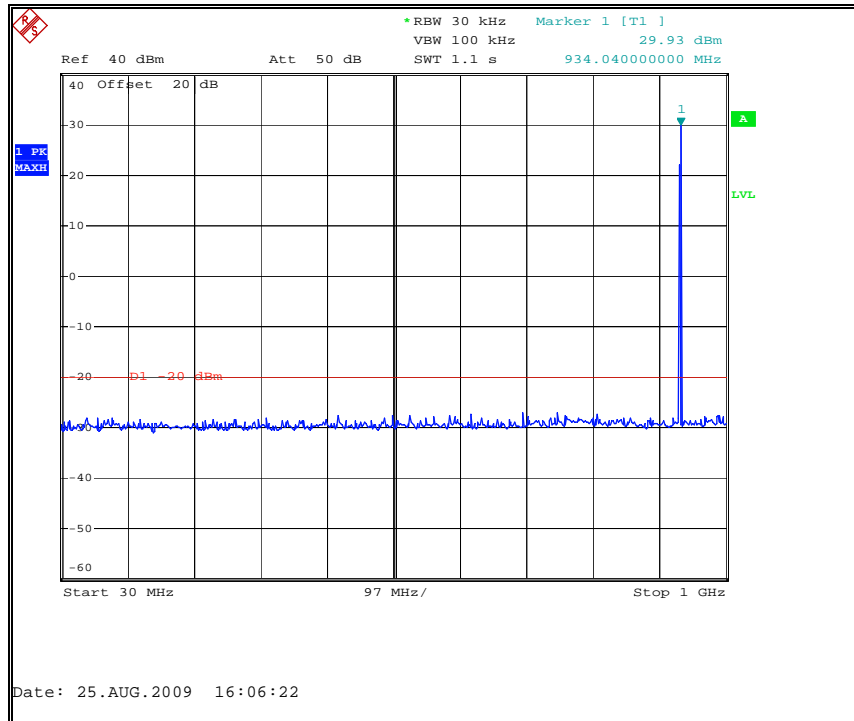

Figure 7.3.2-11: 932.25 MHz – 30MHz to 1GHz

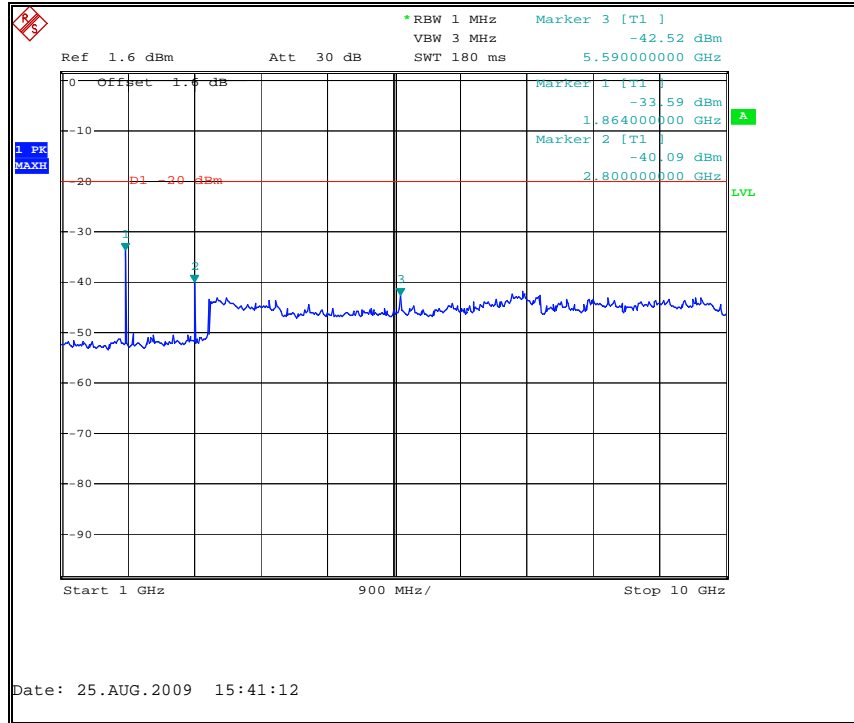

Figure 7.3.2-12: 932.25 MHz – 1GHz to 10GHz

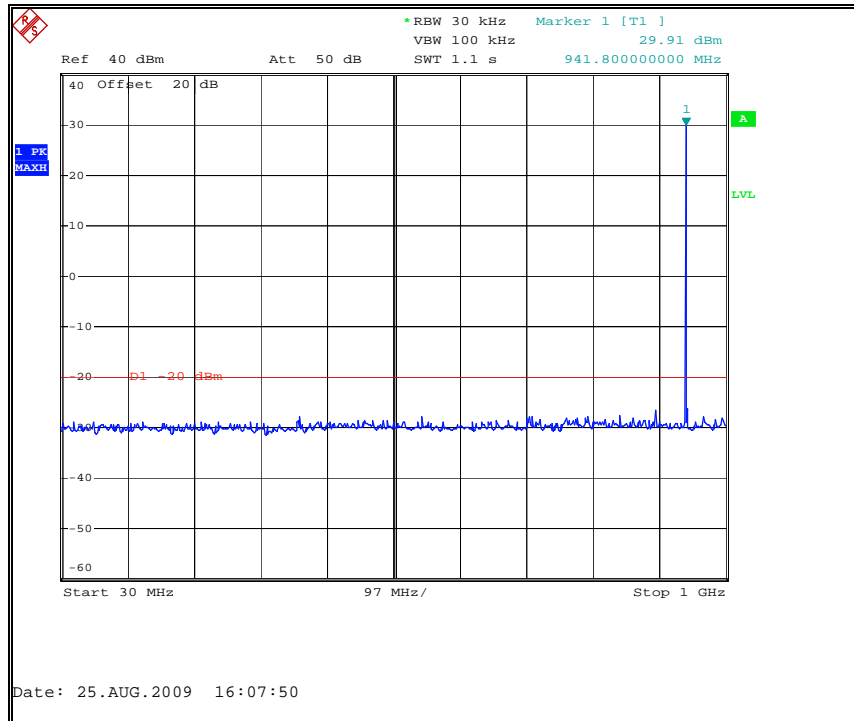

Figure 7.3.2-13: 941.4875 MHz – 30MHz to 1GHz

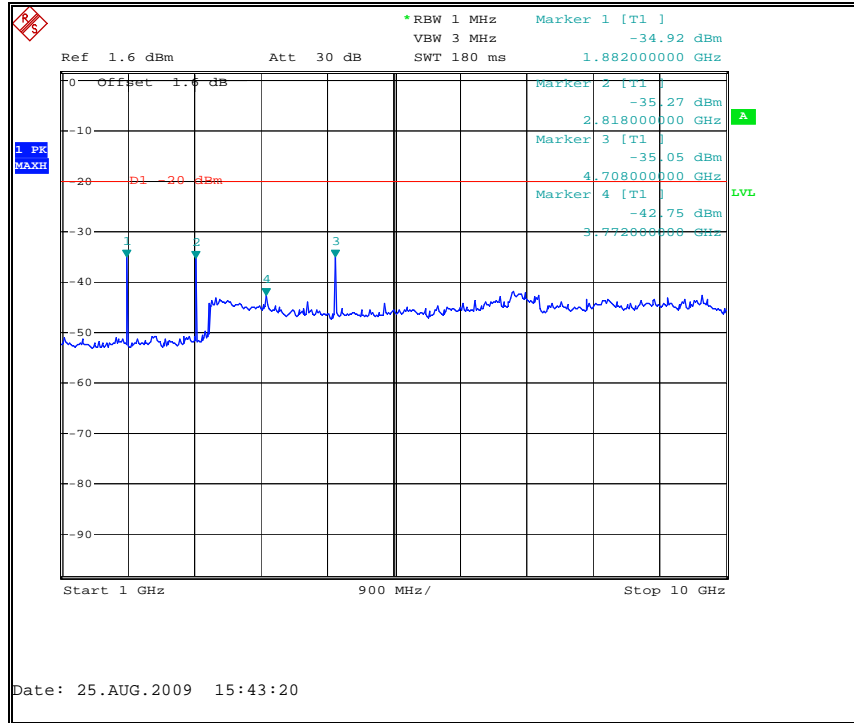

Figure 7.3.2-14: 941.4875 MHz – 1GHz to 10GHz

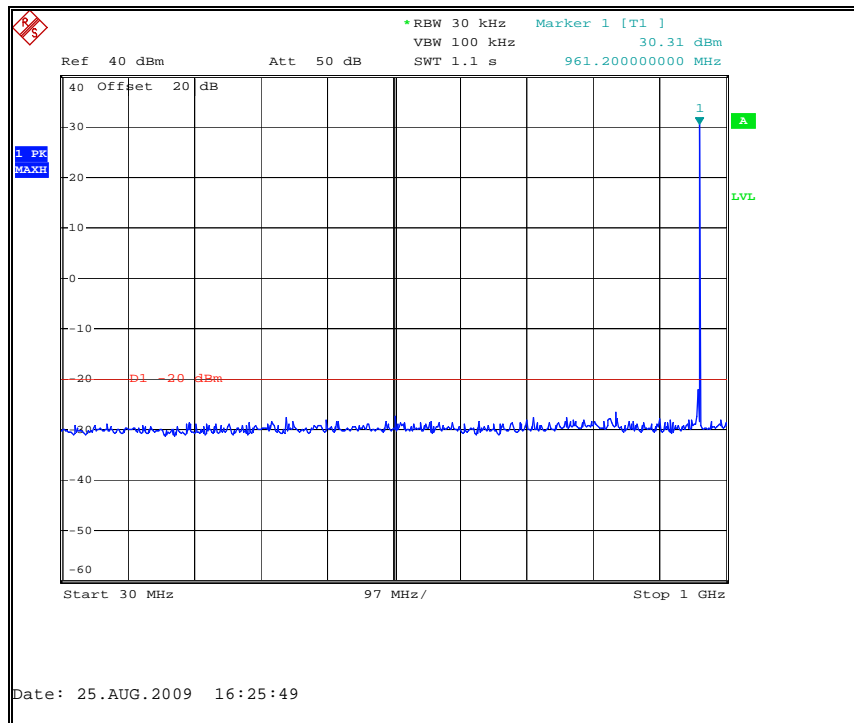

Figure 7.3.2-15: 959.925 MHz – 30MHz to 1GHz

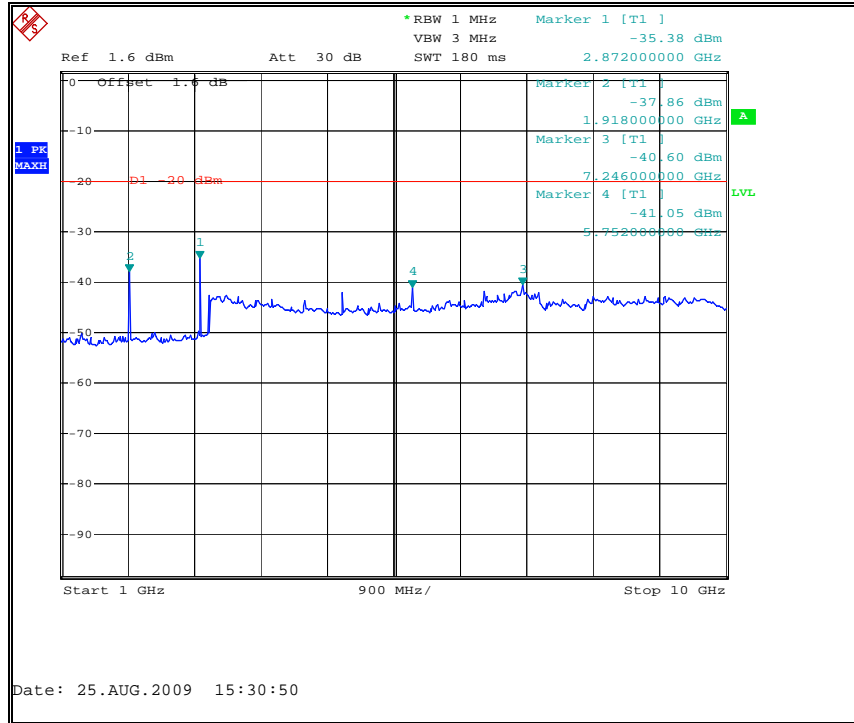

Figure 7.3.2-16: 959.925 MHz – 1GHz to 10GHz

7.4 Field Strength of Spurious Emissions

7.4.1 Measurement Procedure

The equipment under test is placed in the Semi-Anechoic Chamber (described in section 2.3.1) on a wooden table at the turntable center. For each spurious emission, the antenna mast is raised and lowered from one (1) to four (4) meters and the turntable is rotated 360° and the maximum reading on the spectrum analyzer is recorded. This was repeated for both horizontal and vertical polarizations of the receive antenna.

The equipment under test is then replaced with a substitution antenna fed by a signal generator. The signal generator's frequency is set to that of the spurious emission recorded from the equipment under test. The antenna mast is raised and lowered from one (1) to four (4) meters to obtain a maximum reading on the spectrum analyzer. The output of the signal generator is then adjusted until the reading on the spectrum analyzer matches that obtained from the equipment under test. The signal generator level is recorded. The power in dBm of each spurious emission is calculated by correcting the signal generator level for the cable loss and gain of the substitution antenna referenced to a dipole. The spectrum was investigated in accordance to CFR 47 Part 2.1057.

Data was collected at frequencies according to Section 1.3.2. Results of the test are shown below. The magnitude of all spurious emissions not reported were attenuated below the noise floor of the measurement system and therefore not specified in this report.

The equipment under test was evaluated to multiple FCC rule parts with the most stringent limit applied to all measurements.

The EUT was evaluated for all modulation modes with the worst case presented in section 7.4.2 below.

7.4.2 Measurement Results – 520x (“T” Board)

Part 24.133 a(1), a(2), IC RSS-134 6.3(i), (ii)

Table 7.4.2-1: Field Strength of Spurious Emissions – 901.9875 MHz

Frequency (MHz)	Spectrum Analyzer Level (dBm)	Generator Level (dBm)	Antenna Polarity (H/V)	Correction Factors (dB)	Corrected Level (dBm)	Limit (dBm)	Margin (dB)
1803.975	-39.87	-45.10	H	4.83	-40.27	-20.00	20.27
1803.975	-41.24	-46.3	V	4.83	-41.47	-20.00	21.47
2705.9625	-46.35	-47.9	H	5.32	-42.58	-20.00	22.58
2705.9625	-42.18	-41.7	V	5.32	-36.38	-20.00	16.38
3607.95	-52.49	-58.1	H	6.37	-51.73	-20.00	31.73
3607.95	-53.99	-57.4	V	6.37	-51.03	-20.00	31.03
4509.9375	-53.38	-55.9	H	6.96	-48.94	-20.00	28.94
4509.9375	-50.49	-51	V	6.96	-44.04	-20.00	24.04
5411.925	-53.4	-50.8	H	6.46	-44.34	-20.00	24.34
5411.925	-55.92	-52.8	V	6.46	-46.34	-20.00	26.34

NOTE: All frequencies not listed were below the noise floor of the spectrum analyzer.

Table 7.4.2-2: Field Strength of Spurious Emissions – 930.5 MHz

Frequency (MHz)	Spectrum Analyzer Level (dBm)	Generator Level (dBm)	Antenna Polarity (H/V)	Correction Factors (dB)	Corrected Level (dBm)	Limit (dBm)	Margin (dB)
1803.975	-34.85	-39.30	H	4.69	-34.61	-20.00	14.61
1803.975	-34.54	-39.6	V	4.69	-34.91	-20.00	14.91
2705.9625	-43.94	-45.5	H	5.44	-40.06	-20.00	20.06
2705.9625	-42.49	-42.6	V	5.44	-37.16	-20.00	17.16
3607.95	-50.69	-52.9	H	6.27	-46.63	-20.00	26.63
3607.95	-52.21	-53.8	V	6.27	-47.53	-20.00	27.53
4509.9375	-50.87	-49.9	H	6.66	-43.24	-20.00	23.24
4509.9375	-53.08	-55	V	6.66	-48.34	-20.00	28.34
5411.925	-50.54	-47.1	H	6.58	-40.52	-20.00	20.52
5411.925	-50.51	-47.1	V	6.58	-40.52	-20.00	20.52
6313.9125	-55.08	-49.9	H	6.22	-43.68	-20.00	23.68
6313.9125	-52.27	-46.2	V	6.22	-39.98	-20.00	19.98

NOTE: All frequencies not listed were below the noise floor if the spectrum analyzer.

Part 90.210 (j), RSS-119 5.8.8**Table 7.4.2-3: Field Strength of Spurious Emissions – 896.0125MHz**

Frequency (MHz)	Spectrum Analyzer Level (dBm)	Generator Level (dBm)	Antenna Polarity (H/V)	Correction Factors (dB)	Corrected Level (dBm)	Limit (dBm)	Margin (dB)
1792.025	-38.68	-42.00	H	4.86	-37.14	-20.00	17.14
1792.025	-36.04	-37.8	V	4.86	-32.94	-20.00	12.94
2688.0375	-49.68	-53	H	5.30	-47.70	-20.00	27.70
2688.0375	-44.53	-43.9	V	5.30	-38.60	-20.00	18.60
3584.05	-54.93	-59.1	H	6.39	-52.71	-20.00	32.71
3584.05	-55.46	-59.1	V	6.39	-52.71	-20.00	32.71
4480.0625	-54.39	-54	H	6.94	-47.06	-20.00	27.06
4480.0625	-55.03	-56.3	V	6.94	-49.36	-20.00	29.36
5376.075	-55.94	-53.2	H	6.41	-46.79	-20.00	26.79
5376.075	-56.91	-54.2	V	6.41	-47.79	-20.00	27.79
6272.0875	-55.71	-52.3	V	6.40	-45.90	-20.00	25.90
7168.1	-56.25	-50.8	V	5.91	-44.89	-20.00	24.89

NOTE: All frequencies not listed were below the noise floor if the spectrum analyzer.

Table 7.4.2-4: Field Strength of Spurious Emissions – 935.0125MHz

Frequency (MHz)	Spectrum Analyzer Level (dBm)	Generator Level (dBm)	Antenna Polarity (H/V)	Correction Factors (dB)	Corrected Level (dBm)	Limit (dBm)	Margin (dB)
1803.975	-35.10	-39.80	H	4.67	-35.13	-20.00	15.13
1803.975	-33.14	-38.1	V	4.67	-33.43	-20.00	13.43
2705.9625	-42.46	-43.8	H	5.46	-38.34	-20.00	18.34
2705.9625	-41.04	-41	V	5.46	-35.54	-20.00	15.54
3607.95	-50.23	-51.8	H	6.26	-45.54	-20.00	25.54
3607.95	-51.17	-50.5	V	6.26	-44.24	-20.00	24.24
4509.9375	-50.49	-51.7	H	6.61	-45.09	-20.00	25.09
4509.9375	-52.82	-50.7	V	6.61	-44.09	-20.00	24.09
5411.925	-50.59	-46.4	H	6.58	-39.82	-20.00	19.82
5411.925	-52.57	-50.3	V	6.58	-43.72	-20.00	23.72
6313.9125	-54.53	-48.8	H	6.19	-42.61	-20.00	22.61
6313.9125	-50.51	-43	V	6.19	-36.81	-20.00	16.81
7215.9	-54.25	-48.9	H	6.17	-42.73	-20.00	22.73
7215.9	-53.71	-46.7	V	6.17	-40.53	-20.00	20.53

NOTE: All frequencies not listed were below the noise floor if the spectrum analyzer.

Part 101.111 a(6), RSS-119 5.8.6

Table 7.4.2-5: Field Strength of Spurious Emissions – 928.925MHz

Frequency (MHz)	Spectrum Analyzer Level (dBm)	Generator Level (dBm)	Antenna Polarity (H/V)	Correction Factors (dB)	Corrected Level (dBm)	Limit (dBm)	Margin (dB)
1803.975	-37.38	-43.00	H	4.70	-38.30	-20.00	18.30
1803.975	-32.03	-36.9	V	4.70	-32.20	-20.00	12.20
2705.9625	-43.28	-45.3	H	5.43	-39.87	-20.00	19.87
2705.9625	-41.73	-42.5	V	5.43	-37.07	-20.00	17.07
3607.95	-50.28	-53.2	H	6.28	-46.92	-20.00	26.92
3607.95	-51.88	-55.6	V	6.28	-49.32	-20.00	29.32
4509.9375	-51.58	-51.9	H	6.67	-45.23	-20.00	25.23
4509.9375	-51.17	-50.1	V	6.67	-43.43	-20.00	23.43
5411.925	-51.12	-47.5	H	6.58	-40.92	-20.00	20.92
5411.925	-53.03	-49.9	V	6.58	-43.32	-20.00	23.32
6313.9125	-54.58	-49.2	H	6.23	-42.97	-20.00	22.97
6313.9125	-52.49	-44.3	V	6.23	-38.07	-20.00	18.07

NOTE: All frequencies not listed were below the noise floor if the spectrum analyzer.

Table 7.4.2-6: Field Strength of Spurious Emissions – 932.25MHz

Frequency (MHz)	Spectrum Analyzer Level (dBm)	Generator Level (dBm)	Antenna Polarity (H/V)	Correction Factors (dB)	Corrected Level (dBm)	Limit (dBm)	Margin (dB)
1803.975	-34.16	-38.90	H	4.68	-34.22	-20.00	14.22
1803.975	-32.56	-38.6	V	4.68	-33.92	-20.00	13.92
2705.9625	-43.27	-44.9	H	5.45	-39.45	-20.00	19.45
2705.9625	-42.89	-43.9	V	5.45	-38.45	-20.00	18.45
3607.95	-52.35	-56	H	6.27	-49.73	-20.00	29.73
3607.95	-51.76	-53.9	V	6.27	-47.63	-20.00	27.63
4509.9375	-52.14	-51.7	H	6.64	-45.06	-20.00	25.06
4509.9375	-53.34	-53.8	V	6.64	-47.16	-20.00	27.16
5411.925	-52.91	-50.4	H	6.58	-43.82	-20.00	23.82
5411.925	-53.26	-50.9	V	6.58	-44.32	-20.00	24.32
6313.9125	-53.69	-48	H	6.21	-41.79	-20.00	21.79
6313.9125	-51.49	-44.3	V	6.21	-38.09	-20.00	18.09

NOTE: All frequencies not listed were below the noise floor if the spectrum analyzer.

Table 7.4.2-7: Field Strength of Spurious Emissions – 941.4875MHz

Frequency (MHz)	Spectrum Analyzer Level (dBm)	Generator Level (dBm)	Antenna Polarity (H/V)	Correction Factors (dB)	Corrected Level (dBm)	Limit (dBm)	Margin (dB)
1882.975	-36.93	-42.30	H	4.64	-37.66	-20.00	17.66
1882.975	-36.35	-41.1	V	4.64	-36.46	-20.00	16.46
2824.4625	-41.17	-42.6	H	5.48	-37.12	-20.00	17.12
2824.4625	-40.72	-41.7	V	5.48	-36.22	-20.00	16.22
3765.95	-47.52	-47.7	H	6.24	-41.46	-20.00	21.46
3765.95	-49.22	-50.3	V	6.24	-44.06	-20.00	24.06
4707.4375	-45.21	-42.9	H	6.54	-36.36	-20.00	16.36
4707.4375	-45.87	-44.3	V	6.54	-37.76	-20.00	17.76
5648.925	-50.34	-46.1	H	6.59	-39.51	-20.00	19.51
5648.925	-49.6	-45.2	V	6.59	-38.61	-20.00	18.61
6590.4125	-53.59	-47.5	H	6.15	-41.35	-20.00	21.35
6590.4125	-50.94	-45.1	V	6.15	-38.95	-20.00	18.95
8473.3875	-53.15	-47.3	H	6.52	-40.78	-20.00	20.78
8473.3875	-50.31	-41.8	V	6.52	-35.28	-20.00	15.28

NOTE: All frequencies not listed were below the noise floor if the spectrum analyzer.

Table 7.4.2-8: Field Strength of Spurious Emissions – 959.925MHz

Frequency (MHz)	Spectrum Analyzer Level (dBm)	Generator Level (dBm)	Antenna Polarity (H/V)	Correction Factors (dB)	Corrected Level (dBm)	Limit (dBm)	Margin (dB)
1803.975	-39.42	-44.90	H	4.55	-40.35	-20.00	20.35
1803.975	-36.65	-40.6	V	4.55	-36.05	-20.00	16.05
2705.9625	-44.11	-46.1	H	5.56	-40.54	-20.00	20.54
2705.9625	-47.85	-50.5	V	5.56	-44.94	-20.00	24.94
3607.95	-46.17	-45.6	H	6.18	-39.42	-20.00	19.42
3607.95	-47.57	-46.8	V	6.18	-40.62	-20.00	20.62
4509.9375	-43.2	-39.3	H	6.35	-32.95	-20.00	12.95
4509.9375	-43.66	-40.7	V	6.35	-34.35	-20.00	14.35
5411.925	-51.66	-47.7	H	6.59	-41.11	-20.00	21.11
5411.925	-52.85	-48.8	V	6.59	-42.21	-20.00	22.21
6313.9125	-51.38	-43.5	H	6.03	-37.47	-20.00	17.47
6313.9125	-52.67	-44.5	V	6.03	-38.47	-20.00	18.47
7215.9	-51.94	-45.5	H	6.22	-39.28	-20.00	19.28
7215.9	-50.41	-43.7	V	6.22	-37.48	-20.00	17.48
8117.8875	-52.37	-46.1	H	6.58	-39.52	-20.00	19.52

NOTE: All frequencies not listed were below the noise floor if the spectrum analyzer.

7.4.3 Measurement Results – 510x (SOH Board)

Part 24.133 a(1), a(2), IC RSS-134 6.3(i), (ii)

Table 7.4.3-1: Field Strength of Spurious Emissions – 901.9875 MHz

Frequency (MHz)	Spectrum Analyzer Level (dBm)	Generator Level (dBm)	Antenna Polarity (H/V)	Correction Factors (dB)	Corrected Level (dBm)	Limit (dBm)	Margin (dB)
1803.975	-36.60	-41.40	H	4.83	-36.57	-20.00	16.57
1803.975	-37.38	-42.6	V	4.83	-37.77	-20.00	17.77
2705.9625	-48.32	-51.1	H	5.32	-45.78	-20.00	25.78
2705.9625	-51.99	-54.2	V	5.32	-48.88	-20.00	28.88
5411.925	-49.73	-44.8	H	6.46	-38.34	-20.00	18.34
5411.925	-52.34	-47.2	V	6.46	-40.74	-20.00	20.74

NOTE: All frequencies not listed were below the noise floor if the spectrum analyzer.

Table 7.4.3-2: Field Strength of Spurious Emissions – 930.5 MHz

Frequency (MHz)	Spectrum Analyzer Level (dBm)	Generator Level (dBm)	Antenna Polarity (H/V)	Correction Factors (dB)	Corrected Level (dBm)	Limit (dBm)	Margin (dB)
1861	-38.48	-43.30	H	4.69	-38.61	-20.00	18.61
1861	-38.37	-43.3	V	4.69	-38.61	-20.00	18.61
2791.5	-47.92	-49.8	H	5.44	-44.36	-20.00	24.36
2791.5	-52.34	-55.3	V	5.44	-49.86	-20.00	29.86
5583	-47.26	-43.4	H	6.58	-36.82	-20.00	16.82
5583	-51.58	-47.8	V	6.58	-41.22	-20.00	21.22
8374.5	-53.26	-46.6	V	6.47	-40.13	-20.00	20.13

NOTE: All frequencies not listed were below the noise floor if the spectrum analyzer.

Part 90.210 (j), RSS-119 5.8.8**Table 7.4.3-3: Field Strength of Spurious Emissions – 896.0125MHz**

Frequency (MHz)	Spectrum Analyzer Level (dBm)	Generator Level (dBm)	Antenna Polarity (H/V)	Correction Factors (dB)	Corrected Level (dBm)	Limit (dBm)	Margin (dB)
1792.025	-39.14	-42.60	H	4.86	-37.74	-20.00	17.74
1792.025	-33.73	-34.4	V	4.86	-29.54	-20.00	9.54
2688.0375	-50.16	-54.7	H	5.30	-49.40	-20.00	29.40
2688.0375	-51.37	-53.4	V	5.30	-48.10	-20.00	28.10
4480.0625	-54.22	-55.6	H	6.94	-48.66	-20.00	28.66
4480.0625	-54.6	-54.1	V	6.94	-47.16	-20.00	27.16
5376.075	-49.85	-43.8	H	6.41	-37.39	-20.00	17.39
5376.075	-53.1	-48.9	V	6.41	-42.49	-20.00	22.49
6272.0875	-54.98	-51.8	H	6.40	-45.40	-20.00	25.40
8064.1125	-55.51	-50.1	H	6.33	-43.77	-20.00	23.77
8960.125	-54.85	-47.5	H	6.70	-40.80	-20.00	20.80
8960.125	-55.84	-51.3	V	6.70	-44.60	-20.00	24.60

NOTE: All frequencies not listed were below the noise floor if the spectrum analyzer.

Table 7.4.3-4: Field Strength of Spurious Emissions – 935.0125MHz

Frequency (MHz)	Spectrum Analyzer Level (dBm)	Generator Level (dBm)	Antenna Polarity (H/V)	Correction Factors (dB)	Corrected Level (dBm)	Limit (dBm)	Margin (dB)
1870.025	-38.32	-43.40	H	4.67	-38.73	-20.00	18.73
1870.025	-40.97	-46.6	V	4.67	-41.93	-20.00	21.93
2805.0375	-45.46	-47.8	H	5.46	-42.34	-20.00	22.34
2805.0375	-50.01	-53.5	V	5.46	-48.04	-20.00	28.04
5610.075	-49.8	-45	H	6.58	-38.42	-20.00	18.42
5610.075	-51.45	-49.2	V	6.58	-42.62	-20.00	22.62
8415.1125	-53	-48.5	H	6.49	-42.01	-20.00	22.01
8415.1125	-51.71	-44.3	V	6.49	-37.81	-20.00	17.81

NOTE: All frequencies not listed were below the noise floor if the spectrum analyzer.

Part 101.111 a(6), RSS-119 5.8.6**Table 7.4.3-5: Field Strength of Spurious Emissions – 928.925MHz**

Frequency (MHz)	Spectrum Analyzer Level (dBm)	Generator Level (dBm)	Antenna Polarity (H/V)	Correction Factors (dB)	Corrected Level (dBm)	Limit (dBm)	Margin (dB)
1857.85	-36.85	-42.30	H	4.70	-37.60	-20.00	17.60
1857.85	-39.06	-44.4	V	4.70	-39.70	-20.00	19.70
2786.775	-47.64	-51.1	H	5.43	-45.67	-20.00	25.67
2786.775	-52.37	-55.6	V	5.43	-50.17	-20.00	30.17
5573.55	-47.67	-42.2	H	6.58	-35.62	-20.00	15.62
5573.55	-52.75	-49.7	V	6.58	-43.12	-20.00	23.12
8360.325	-53.23	-46.7	V	6.47	-40.23	-20.00	20.23

NOTE: All frequencies not listed were below the noise floor if the spectrum analyzer.

Table 7.4.3-6: Field Strength of Spurious Emissions – 932.25MHz

Frequency (MHz)	Spectrum Analyzer Level (dBm)	Generator Level (dBm)	Antenna Polarity (H/V)	Correction Factors (dB)	Corrected Level (dBm)	Limit (dBm)	Margin (dB)
1864.5	-38.15	-43.30	H	4.68	-38.62	-20.00	18.62
1864.5	-37.97	-43.1	V	4.68	-38.42	-20.00	18.42
2796.75	-46.68	-48.9	H	5.45	-43.45	-20.00	23.45
2796.75	-50.51	-53.4	V	5.45	-47.95	-20.00	27.95
5593.5	-51.27	-47.8	H	6.58	-41.22	-20.00	21.22
5593.5	-50.72	-47.1	V	6.58	-40.52	-20.00	20.52
8390.25	-51.91	-44.9	V	6.48	-38.42	-20.00	18.42

NOTE: All frequencies not listed were below the noise floor if the spectrum analyzer.

Table 7.4.3-7: Field Strength of Spurious Emissions – 941.4875MHz

Frequency (MHz)	Spectrum Analyzer Level (dBm)	Generator Level (dBm)	Antenna Polarity (H/V)	Correction Factors (dB)	Corrected Level (dBm)	Limit (dBm)	Margin (dB)
1882.975	-38.73	-44.20	H	4.64	-39.56	-20.00	19.56
1882.975	-39.75	-44.3	V	4.64	-39.66	-20.00	19.66
2824.4625	-38.12	-39.5	H	5.48	-34.02	-20.00	14.02
2824.4625	-42.92	-44.3	V	5.48	-38.82	-20.00	18.82
3765.95	-51.5	-53.9	H	6.24	-47.66	-20.00	27.66
3765.95	-52.16	-54.7	V	6.24	-48.46	-20.00	28.46
4707.4375	-44.44	-42.2	H	6.54	-35.66	-20.00	15.66
4707.4375	-50.82	-50	V	6.54	-43.46	-20.00	23.46
5648.925	-48.56	-43.8	H	6.59	-37.21	-20.00	17.21
5648.925	-51.02	-47.9	V	6.59	-41.31	-20.00	21.31
8473.3875	-53.31	-48.1	H	6.52	-41.58	-20.00	21.58
8473.3875	-52.29	-45.8	V	6.52	-39.28	-20.00	19.28

NOTE: All frequencies not listed were below the noise floor if the spectrum analyzer.

Table 7.4.3-8: Field Strength of Spurious Emissions – 959.925MHz

Frequency (MHz)	Spectrum Analyzer Level (dBm)	Generator Level (dBm)	Antenna Polarity (H/V)	Correction Factors (dB)	Corrected Level (dBm)	Limit (dBm)	Margin (dB)
1919.85	-38.50	-50.40	H	4.55	-45.85	-20.00	25.85
1919.85	-39.85	-44	V	4.55	-39.45	-20.00	19.45
2879.775	-38.78	-40	H	5.56	-34.44	-20.00	14.44
2879.775	-42.52	-43.1	V	5.56	-37.54	-20.00	17.54
3839.7	-43.48	-41.6	H	6.18	-35.42	-20.00	15.42
3839.7	-46.86	-46.4	V	6.18	-40.22	-20.00	20.22
4799.625	-37.84	-33.9	H	6.35	-27.55	-20.00	7.55
4799.625	-45.69	-43.1	V	6.35	-36.75	-20.00	16.75
5759.55	-44.85	-38.9	H	6.59	-32.31	-20.00	12.31
5759.55	-48.66	-43.5	V	6.59	-36.91	-20.00	16.91
8639.325	-51.96	-45.4	H	6.58	-38.82	-20.00	18.82
8639.325	-52.98	-46.7	V	6.58	-40.12	-20.00	20.12

NOTE: All frequencies not listed were below the noise floor if the spectrum analyzer.

7.5 Frequency Stability

7.5.1 Measurement Procedure

The equipment under test is placed inside an environmental chamber. The RF output is directly coupled to the input of the measurement equipment and a power supply is attached to the primary supply voltage.

Frequency measurements were made at the extremes of the of temperature range -30°C to $+50^{\circ}\text{C}$ and at intervals of 10°C at normal supply voltage. A period of time sufficient to stabilize all components of the equipment was allowed at each frequency measurement. At a temperature 20°C the supply voltage was varied to the battery endpoint voltage. The maximum variation of frequency was recorded.

Data was collected at a frequency within each Rule Part with the most stringent limit from all rule parts applied. Results of the test are shown below in Figures 7.5.2-1 through 7.5.2-3.

7.5.2 Measurement Results

PART 24.135, IC RSS-134 (7)

Frequency Stability				
		Frequency (MHz):	930.5	
		Deviation Limit (PPM):	1.0ppm	
Temperature	Frequency	Frequency Error	Voltage	Voltage
C	MHz	(PPM)	(%)	(VAC)
-30 C	930.499557	-0.476	100%	3.65
-20 C	930.499788	-0.228	100%	3.65
-10 C	930.499745	-0.274	100%	3.65
0 C	930.499709	-0.313	100%	3.65
10 C	930.499799	-0.216	100%	3.65
20 C	930.499954	-0.049	100%	3.65
30 C	930.499883	-0.126	100%	3.65
40 C	930.499647	-0.379	100%	3.65
50 C	930.499619	-0.409	100%	3.65
20 C	930.499970	-0.032	Endpoint	3.400

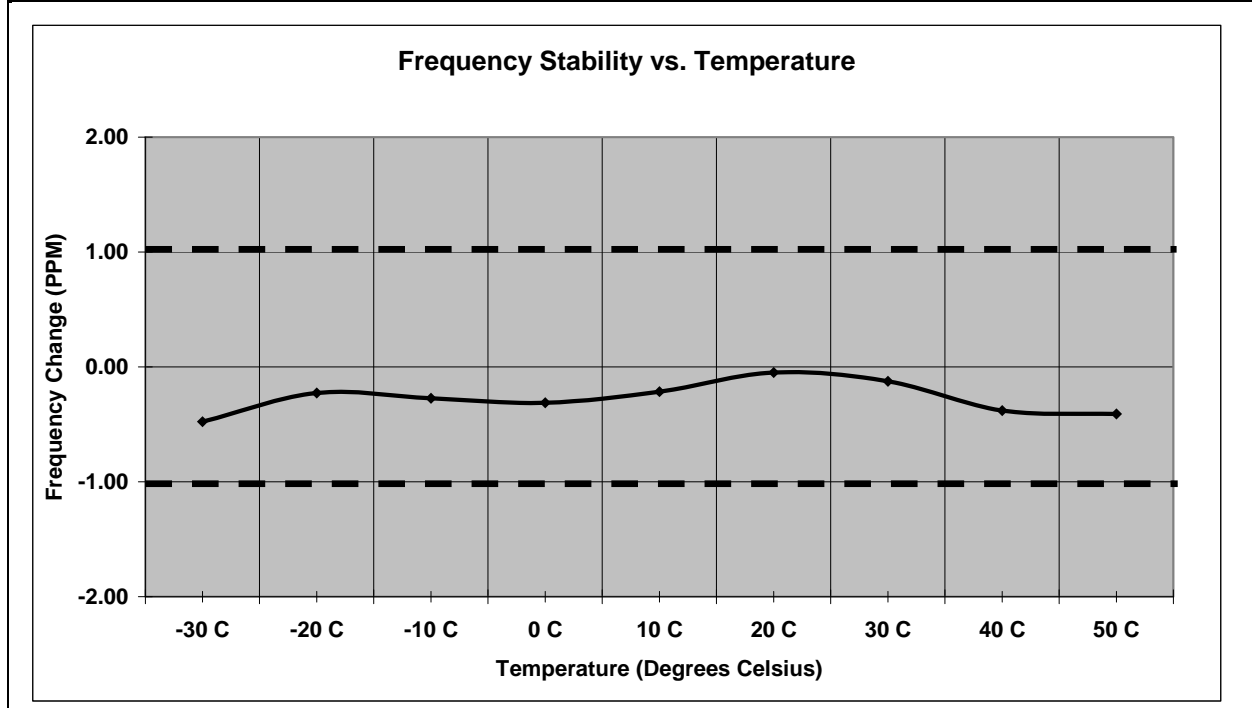

Figure 7.5.2-1: Frequency Stability – 930.5MHz

PART 90.213, RSS-119 5.3

Frequency Stability				
		Frequency (MHz):	896.01875	
		Deviation Limit (PPM):	1.0ppm	
Temperature	Frequency	Frequency Error	Voltage	Voltage
C	MHz	(PPM)	(%)	(VAC)
-30 C	896.018313	-0.488	100%	3.65
-20 C	896.018510	-0.268	100%	3.65
-10 C	896.018528	-0.248	100%	3.65
0 C	896.018464	-0.319	100%	3.65
10 C	896.018538	-0.237	100%	3.65
20 C	896.018728	-0.025	100%	3.65
30 C	896.018652	-0.109	100%	3.65
40 C	896.018422	-0.366	100%	3.65
50 C	896.018362	-0.433	100%	3.65
20 C	896.018720	-0.033	Endpoint	3.400

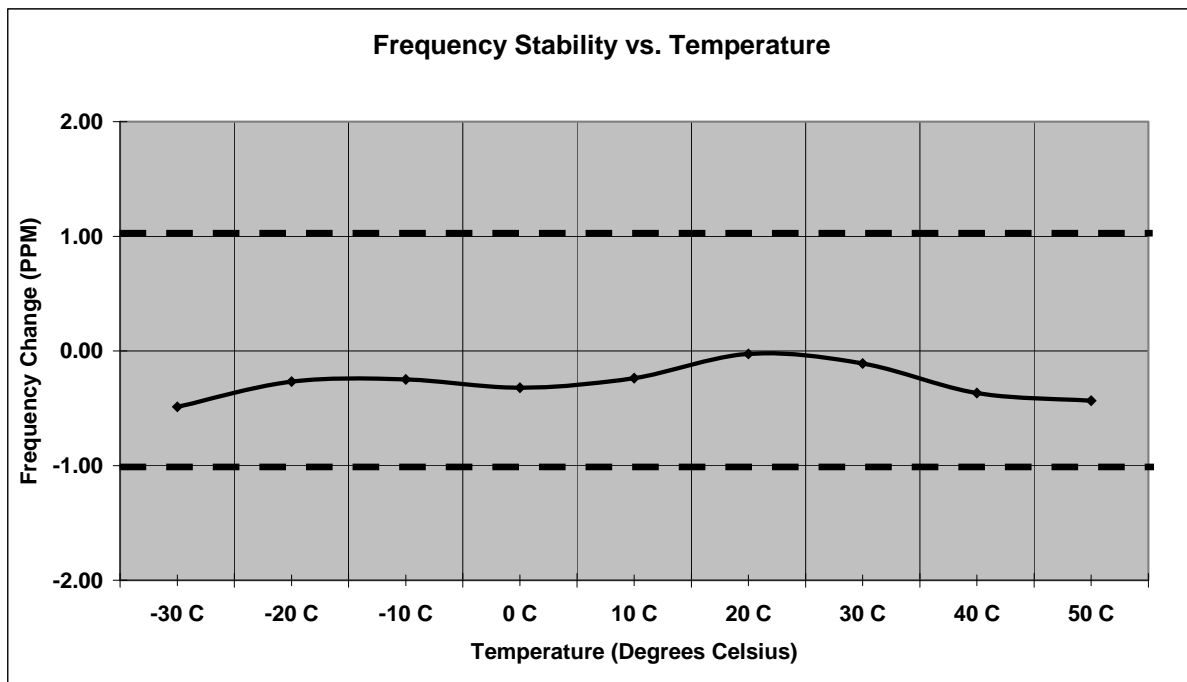

Figure 7.5.2-2: Frequency Stability – 896.01875MHz

PART 101.107, RSS-119 5.3

Frequency Stability				
		Frequency (MHz):	959.925	
		Deviation Limit (PPM):	1.0ppm	
Temperature	Frequency	Frequency Error	Voltage	Voltage
C	MHz	(PPM)	(%)	(VAC)
-30 C	959.924565	-0.453	100%	3.65
-20 C	959.924805	-0.203	100%	3.65
-10 C	959.924733	-0.278	100%	3.65
0 C	959.924703	-0.309	100%	3.65
10 C	959.924853	-0.153	100%	3.65
20 C	959.924976	-0.025	100%	3.65
30 C	959.924854	-0.152	100%	3.65
40 C	959.924630	-0.385	100%	3.65
50 C	959.924636	-0.379	100%	3.65
20 C	959.924971	-0.030	Endpoint	3.400

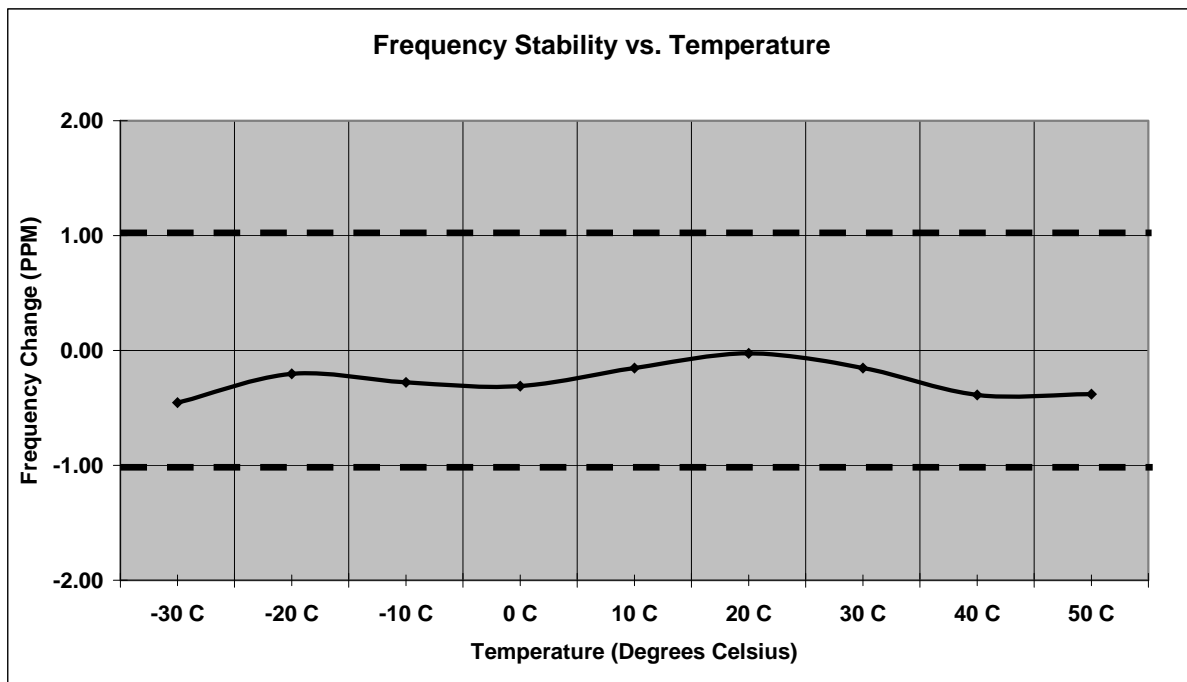

Figure 7.5.2-3: Frequency Stability – 959.9250MHz

7.6 Radiated Emissions (Unintentional Radiators/Receiver)

7.6.1 Measurement Procedure

Radiated emissions tests were performed over the frequency range of 30MHz to 5GHz. Measurements of the radiated field strength were made at a distance of 3m from the boundary of the equipment under test (EUT) and the receiving antenna. The antenna height was varied from 1m to 4m so that the maximum radiated emissions level would be detected. Radiated measurements above 30MHz and below 1GHz were made with the Spectrum Analyzer’s resolution bandwidth set to 120 KHz using a Quasi-peak detector. Above 1GHz, peak and average measurements are taken with the RBW and VBW were set to 1MHz and 3MHz respectively. This was repeated for both horizontal and vertical polarizations of the receive antenna.

The field strength of each radiated emission is calculated by correcting the EMI receiver level for cable loss, amplifier gain, and antenna correction factors.

$$\text{Field Strength (dBuV/m)} = \text{EMI Receiver Level (dBuV)} + \text{Cable Loss (dB)} - \text{Amplifier Gain (dB)} + \text{Antenna Correction Factor (1/m)}$$

Results of the test are shown below in Table 7.6.2-1 and Table 7.6.3-1.

7.6.2 Measurement Results – 520x (“T” Board)

Part 15.109, IC RSS-Gen (6)

Table 7.6.2-1: Radiated Emissions Tabulated Data

Frequency (MHz)	Level (dBuV)		Antenna Polarity (H/V)	Correction Factors (dB)	Corrected Level (dBuV/m)		Limit (dBuV/m)		Margin (dB)	
	pk	Qpk/Avg			pk	Qpk/Avg	pk	Qpk/Avg	pk	Qpk/Avg
30.47	-----	25.18	V	-8.57	-----	16.61	-----	40.0	-----	23.39
315	-----	28.31	V	-11.10	-----	17.21	-----	46.0	-----	28.79
343.63	-----	31.99	V	-9.59	-----	22.40	-----	46.0	-----	23.60
827.58	-----	34.50	V	0.70	-----	35.20	-----	46.0	-----	10.80
828.88	-----	32.09	V	0.70	-----	32.79	-----	46.0	-----	13.21
902.07	-----	30.44	V	0.72	-----	31.16	-----	46.0	-----	14.84

Note: Measurements taken above 903 MHz were below the noise floor of the measurement equipment.

7.6.3 Measurement Results – 510x (SOH Board)

Part 15.109, IC RSS-Gen (6)

Table 7.6.3-1: Radiated Emissions Tabulated Data

Frequency (MHz)	Level (dBuV)		Antenna Polarity (H/V)	Correction Factors (dB)	Corrected Level (dBuV/m)		Limit (dBuV/m)		Margin (dB)	
	pk	Qpk/Avg			pk	Qpk/Avg	pk	Qpk/Avg	pk	Qpk/Avg
31.06	-----	18.76	V	-8.91	-----	9.85	-----	40.0	-----	30.15
200.46	-----	22.07	V	-14.02	-----	8.05	-----	43.5	-----	35.45
314.98	-----	27.83	V	-11.10	-----	16.73	-----	46.0	-----	29.27
343.63	-----	31.74	V	-9.59	-----	22.15	-----	46.0	-----	23.85
827.36	-----	32.02	V	0.70	-----	32.72	-----	46.0	-----	13.28
915.01	-----	30.67	V	1.10	-----	31.77	-----	46.0	-----	14.23

Note: Measurements taken above 916 MHz were below the noise floor of the measurement equipment.

8.0 CONCLUSION

In the opinion of ACS, Inc. model WFL, including both variants, meets all the requirements of FCC Part 24, 90, and 101 as well as IC RSS-119 and RSS-134 as applicable.

End Report