

Certification Test Report

FCC ID: SDBVGBM4601

FCC Rule Part: CFR 47 Part 101 Subpart C

ACS Report Number: 12-2008.W06.1A

**Applicant: Sensus Metering Systems, Inc.
Model: M4601**

Test Begin Date: January 17, 2012

Test End Date: January 26, 2012

Report Issue Date: March 2, 2012



For The Scope of Accreditation Under Certificate Number AT-1533

For The Scope of Accreditation Under Lab Code 200612-0

This report must not be used by the client to claim product certification, approval, or endorsement by ACLASS, NVLAP, ANSI, or any agency of the Federal Government.

Project Manager:



**Thierry Jean-Charles
EMC Engineer
Advanced Compliance Solutions, Inc.**

Reviewed by:



**Kirby Munroe
Director, Wireless Certifications
Advanced Compliance Solutions, Inc.**

This test report shall not be reproduced except in full. This report may be reproduced in part with prior written consent of ACS, Inc. The results contained in this report are representative of the sample(s) submitted for evaluation.

This report contains 18 pages

Table of Content

1.0 GENERAL -----	3
1.1 PURPOSE -----	3
1.2 PRODUCT DESCRIPTION -----	3
1.3 TEST METHODOLOGY -----	3
1.4 EMISSION DESIGNATORS -----	5
2.0 TEST FACILITIES -----	6
2.1 LOCATION -----	6
2.2 LABORATORY ACCREDITATIONS/RECOGNITIONS/CERTIFICATIONS -----	6
2.3 RADIATED & CONDUCTED EMISSIONS TEST SITE DESCRIPTION -----	7
3.0 APPLICABLE STANDARD REFERENCES -----	9
4.0 LIST OF TEST EQUIPMENT -----	10
6.0 EQUIPMENT UNDER TEST SETUP AND BLOCK DIAGRAM -----	11
7.0 SUMMARY OF TESTS -----	12
7.1 RF POWER OUTPUT -----	12
7.2 OCCUPIED BANDWIDTH (EMISSION LIMITS) -----	13
7.3 SPURIOUS EMISSIONS AT ANTENNA TERMINALS -----	14
7.4 FIELD STRENGTH OF SPURIOUS EMISSIONS -----	15
7.5 FREQUENCY STABILITY -----	16
8.0 CONCLUSION -----	18

1.0 GENERAL

1.1 Purpose

The purpose of this report is to demonstrate compliance with Part 2 Subpart J and Part 101 Subpart C of the FCC's Code of Federal Regulations.

1.2 Product Description

The Sensus FlexNet Vehicle Gateway Basestation (VGB) is a portable radio-based device used for the acquisition of data from utility meters and other field-based diagnostic instruments. The VGB sends an alert signal to the meter SmartPoint or ancillary device. Upon receipt of the alert, the SmartPoint responds by transmitting its most recent reading. Once received, the SmartPoint returns to a low-power listening mode. The operator has the option of directing the VGB to signal all endpoints within range (blind reading mode), or to select endpoints (geographic reading mode).

The VGB is compact and portable, allowing it to be used in any vehicle providing 12-volt DC power. One of the prime features of the VGB model M4601 is that it provides the ability to read both Sensus RadioRead and FlexNet drive-by technologies. By combining both technologies, this solution allows the utility to maintain and utilize their existing RadioRead technology and reading equipment as they transition to FlexNet. Dual reading capability allows the utility to transition to the latest FlexNet technology and positions themselves to migrate to a fixed base platform in the future.

Manufacturer Information:
Sensus Metering Systems, Inc.
639 Davis Drive
Morrisville, NC 27560

Test Sample Serial Numbers: ACS#1

Test Sample Condition: The unit was in good operating conditions with no physical damages.

1.3 Test Methodology

1.3.1 Configurations and Justification

The M4601 was tested for radiated emissions and RF conducted measurements. The power level was set to about 34 dBm through the NA2WVGBTestutility software which was set to Power Level 1.

The radiated emissions evaluations were performed up to the 10th harmonic with the EUT terminated with a 50-ohm load. The VGB powers from a car battery and is not meant to be connected both directly or indirectly to the AC mains. Therefore, it is exempted from power line conducted emissions evaluation.

In order to meet the unintentional emissions requirements, the following modifications were implemented on the EUT.

Table 1.3.1: Equipment under Test Modifications

Modification	Description	Location
Ferrite	FAIR-RITE Model 0431164281 (single pass)	VGB Power In cables inside Chassis, 1 cm from connector
Ferrite	FAIR-RITE Model 0431164281 (single pass)	VGB to VXU power cables inside chassis, 1 cm from connector
Ferrite	FAIR-RITE Model 0431164951 (Single Pass)	USB Cable to Computer, 4 cm from the USB B connector
Gasket Material	Chomerics 4850-10-0610-0400	N-type connector of the Duplexer

The M4601 is available with two versions of demodulator cards, CPC1 and CPC2, for incoming RF signals, both of which were evaluated for unintentional emissions. The evaluations for unintentional emissions are documented separately in a verification test report.

1.3.2 In-Band Testing Methodology

The EUT is designed to operate in multiple bands under the requirements of CFR 47 Parts 101. The following is a list of the frequency bands of operation sorted based on the FCC rule parts in which the band is associated.

CFR Title 47 Rule Part	Frequency Band of Operation (MHz)
101	959.85 - 960

Based on the requirements set forth in accordance 47 CFR 2.1046-2.1057 as stated above, the methodology in selecting the places to test in the available bands of operation is outlined in the following table.

CFR Title 47 Rule Part	Frequency Band of Operation (MHz)	Location in the Range of Operation	Approx. Test Freq.
101	959.85 - 960	Middle	959.925

1.4 Emission Designators

The M4601 transmitter produces two distinct modulation formats. The emissions designators for the modulation types used by the M4601 transmitter are as follows:

EMISSIONS DESIGNATORS:
 MPass 5k (FSK): 5K90F1D
 MPass 10k (FSK): 11K8F1D

2.0 TEST FACILITIES

2.1 Location

The radiated and conducted emissions test sites are located at the following address:

Site 1

Advanced Compliance Solutions, Inc.
3998 FAU Blvd, Suite 310
Boca Raton, Florida 33431
Phone: (561) 961-5585
Fax: (561) 961-5587
www.acstestlab.com

Site 2

Advanced Compliance Solutions, Inc.
5015 B.U. Bowman Drive
Buford GA 30518
Phone: (770) 831-8048
Fax: (770) 831-8598
www.acstestlab.com

2.2 Laboratory Accreditations/Recognitions/Certifications

Site 1

ACS, Boca Raton, Florida, is accredited to ISO/IEC 17025 by ANSI-ASQ National Accreditation Board under their ACLASS program and has been issued certificate number AT-1533 in recognition of this accreditation.

Site 2

ACS, Buford, GA is accredited to ISO/IEC 17025 by the National Institute of Standards and Technology under their National Voluntary Laboratory Accreditation Program (NVLAP).

Unless otherwise specified, all test methods described within this report are covered under the respective test site ISO/IEC 17025 scope of accreditation.

2.3 Radiated & Conducted Emissions Test Site Description

2.3.1 Semi-Anechoic Chamber Test Site

The EMC radiated test facility consists of an RF-shielded enclosure. The interior dimensions of the indoor semi-anechoic chamber are approximately 48 feet (14.6 m) long by 36 feet (10.8 m) wide by 24 feet (7.3 m) high and consist of rigid, 1/8 inch (0.32 cm) steel-clad, wood core modular panels with steel framing. In the shielded enclosure, the faces of the panels are galvanized and the chamber is self-supporting. 8-foot RF absorbing cones are installed on 4 walls and the ceiling. The steel-clad ground plane is covered with vinyl floor.

The turntable is driven by pneumatic motor, which is capable of supporting a 2000 lb. load. The turntable is flushed with the chamber floor which it is connected to, around its circumference, with metallic loaded springs. An EMCO Model 1051 Multi-device Controller controls the turntable position.

A pneumatic motor is used to control antenna polarizations and height relative to the ground. The height information is displayed on the control unit EMCO Model 1050.

The control room is an RF shielded enclosure attached to the semi-anechoic chamber with two bulkhead panels for connecting RF, and control cables. The dimension of the room is 7.3 m x 4.9 m x 3 m high and the entrance doors of both control and conducted rooms are 3 feet (0.91 m) by 7 feet (2.13 m).

A diagram of the Semi-Anechoic Chamber Test Site is shown in Figure 2.3.1-1 below:

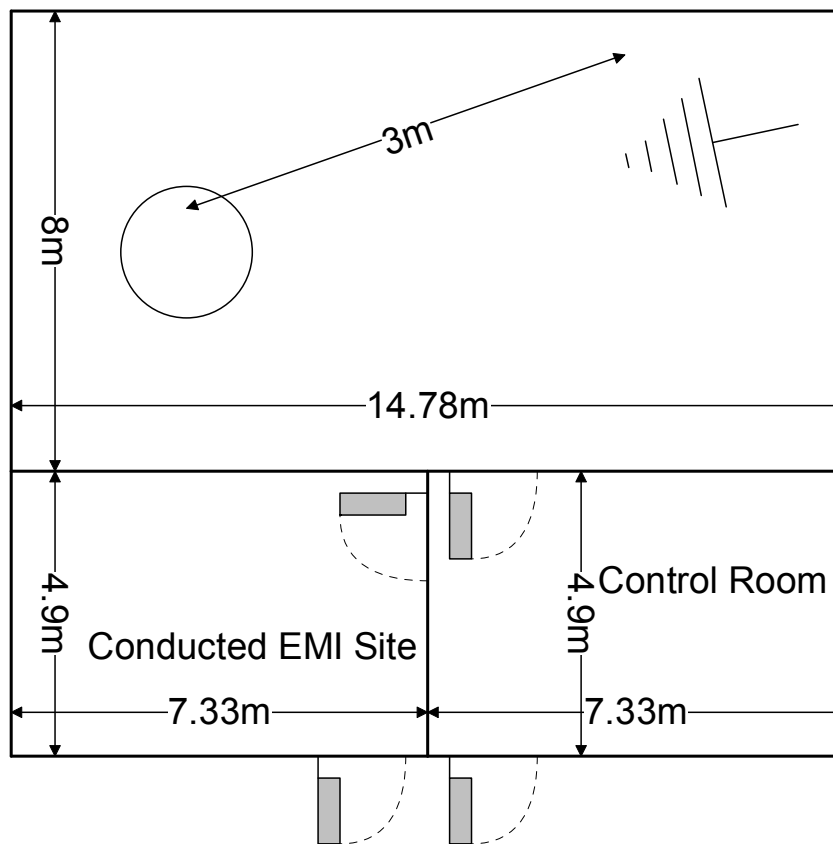

Figure 2.3.1-1: Semi-Anechoic Chamber Test Site

2.3.2 Conducted Emissions Test Site Description

The dimensions of the shielded conducted room are 7.3 x 4.9 x 3 m³. As per ANSI C63.4 2003 requirements, the data were taken using two LISNs; a Solar Model 8028-50 50 Ω/50 μH and an EMCO Model 3825, which are installed as shown in Photograph 3. For 220 V, 50 Hz, a Polarad LISN (S/N 879341/048) is used in conjunction with a 1 kVA, 50 Hz/220 V EDGAR variable frequency generator, Model 1001B, to filter conducted noise from the generator.

A diagram of the room is shown below in figure 2.3.2-1:

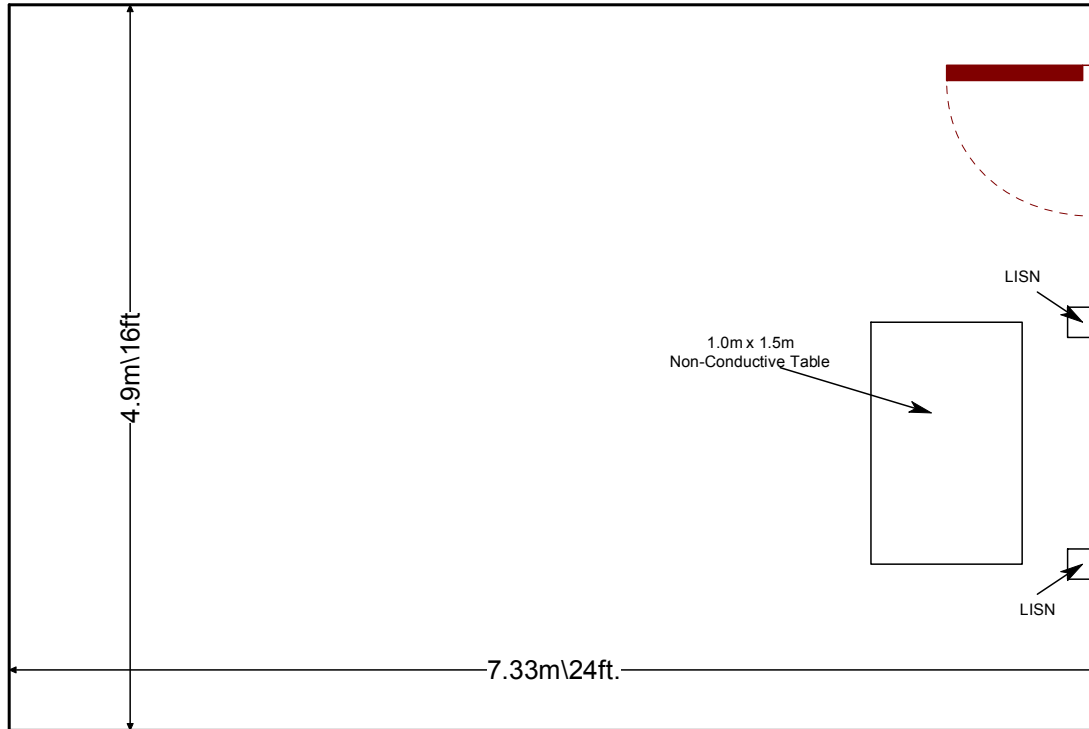

Figure 2.3.2-1: AC Mains Conducted EMI Site

3.0 APPLICABLE STANDARD REFERENCES

The following standards were used:

- 1 - ANSI C63.4-2003: Method of Measurements of Radio-Noise Emissions from Low-Voltage Electrical and Electronic Equipment in the 9 kHz to 40GHz - 2003
- 2 - US Code of Federal Regulations (CFR): Title 47, Part 2, Subpart J: Equipment Authorization Procedures - 2012
- 3 - US Code of Federal Regulations (CFR): Title 47, Part 101, Subpart C: Fixed Microwave Services - 2012
- 4 – TIA-603-C: Land Mobile FM or PM - Communications Equipment - Measurement and Performance Standards – 2004

4.0 LIST OF TEST EQUIPMENT

The calibration interval of test equipment is annually or the manufacturer's recommendations. Where the calibration interval deviates from the annual cycle based on the instrument manufacturer's recommendations, it shall be stated below.

Table 4-1: Test Equipment

AssetID	Manufacturer	Model #	Equipment Type	Serial #	Last Calibration Date	Calibration Due Date
140	Thermotron	SM-16C	Environmental Chamber	19639	9/20/2011	8/30/2012
283	Rohde & Schwarz	FSP40	Spectrum Analyzers	1000033	8/26/2011	8/26/2012
523	Agilent	E7405	Spectrum Analyzers	MY45103293	1/5/2011	1/5/2013
1161	Electro Metrics	RGA-180	Antennas	2121	4/11/2011	4/11/2013
1265	Weinschel	48-10-33	Attenuators	BX7204	12/30/2011	12/30/2012
2002	EMCO	3108	Antennas	2147	11/30/2011	11/30/2013
2004	EMCO	3146	Antennas	1385	11/30/2011	11/30/2013
2006	EMCO	3115	Antennas	2573	3/2/2011	3/2/2013
2011	Hewlett-Packard	HP 8447D	Amplifiers	2443A03952	1/2/2012	1/2/2013
2037	ACS Boca	Chamber EMI Cable Set	Cable Set	2037	1/2/2012	1/2/2013
2075	Hewlett Packard	8495B	Attenuators	2626A11012	1/2/2012	1/2/2013
2078	ACS Boca	Substitution Cable Set	Cable Set	2078	1/12/2012	1/12/2013
2082	Teledyne Storm Products	90-010-048	Cables	2082	6/6/2011	6/6/2012
2091	Agilent Technologies, Inc.	8573A	Spectrum Analyzers	2407A03233	12/12/2011	12/12/2013
RE586	Agilent Technologies, Inc.	83017A	Amplifiers	3123A00168	9/23/2011	9/23/2012

NCR=No Calibration Required

5.0 SUPPORT EQUIPMENT

Table 5-1: Support Equipment

Diagram #	Manufacturer	Equipment Type	Model Number	Serial Number
1	Narda	40 Watt Termination	376BNF	9401
2	BK Precision	DC Power Supply	1692	S940035931
3	Dell	Laptop	Latitude D820	11165723425
4	Dell	Charger	HA65NS0-00	CN-0DF261-47890-720-N253
5	FAIR-RITE	Ferrite Clamp	0431164951	N/A

6.0 EQUIPMENT UNDER TEST SETUP AND BLOCK DIAGRAM

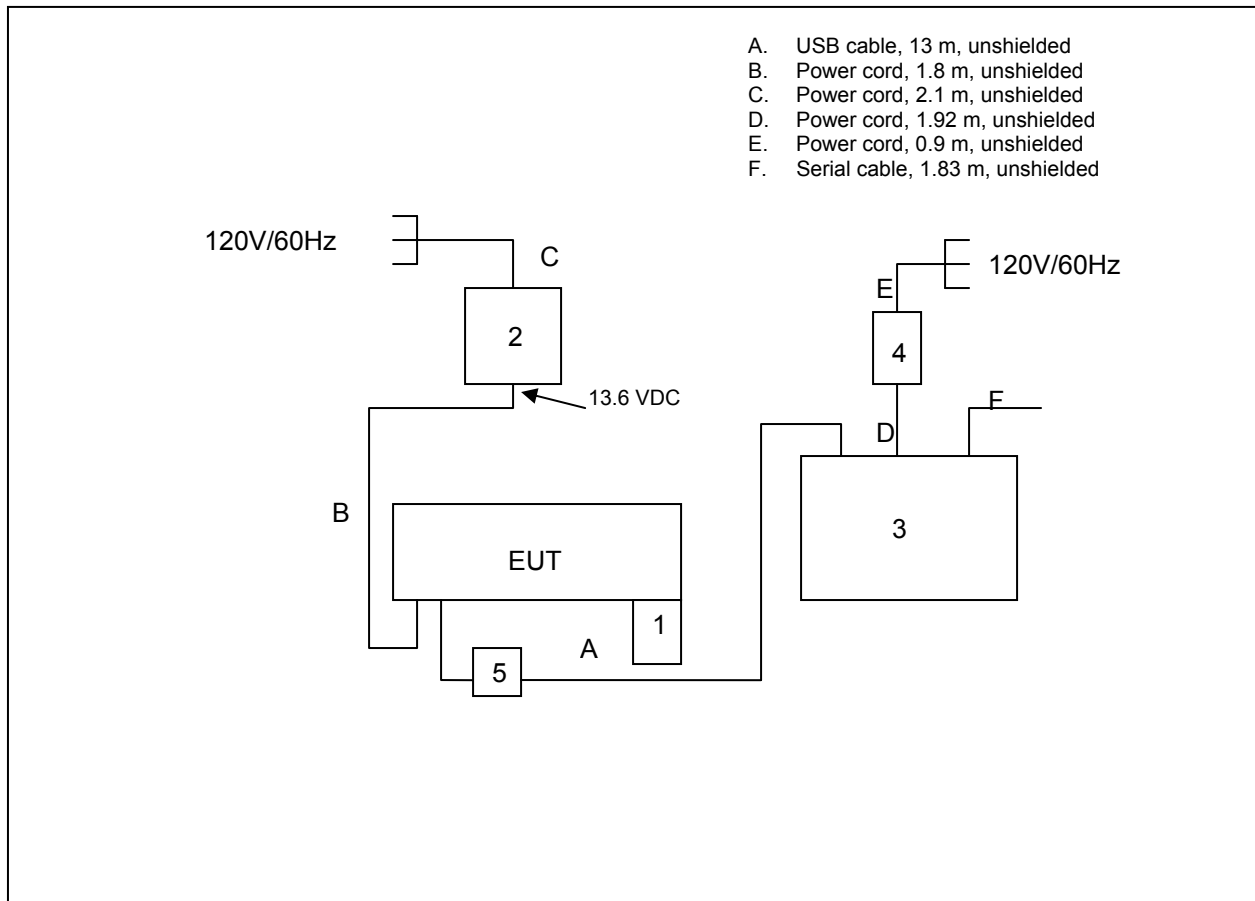

Figure 6-1: EUT Test Setup

7.0 SUMMARY OF TESTS

Along with the tabular data shown below, plots were taken of all signals deemed important enough to document.

Table 7-1: Test Results Summary

Test Parameter	Test Site	Test Summary
RF Power Output	1	Pass
Occupied Bandwidth (Emissions Limits)	1	Pass
Spurious Emissions at Antenna Terminals	1	Pass
Field Strength of Spurious Emissions	1	Pass
Frequency Stability	2	Pass

7.1 RF Power Output

7.1.1 Measurement Procedure

The RF output of the equipment under test was directly connected to the input of the Spectrum Analyzer through a 50 dB passive attenuator. The resolution and video bandwidths of the spectrum analyzer were set at sufficient levels, >> signal bandwidth, to produce accurate results. The internal correction factors of the spectrum analyzer were employed to correct for any cable or attenuator losses. Results are shown below in Table 7.1.2-1 and Figure 7.1.2-1.

7.1.2 Measurement Results

Part 101.113(a)

Table 7.1.2-1: Peak Output Power

Frequency (MHz)	FCC Rule Part	Output Power (dBm)
959.925	101	34.01

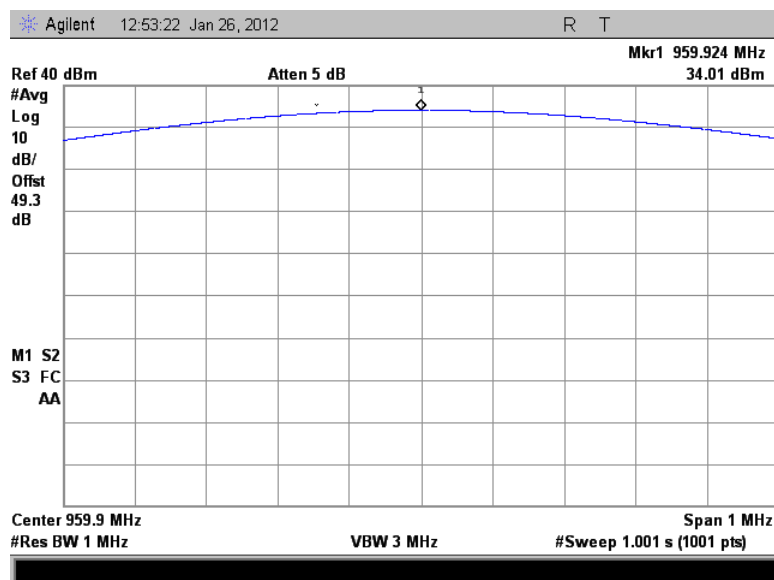

Figure 7.1.2-1: Peak Output Power 959.925 MHz

7.2 Occupied Bandwidth (Emission Limits)

7.2.1 Measurement Procedure

The RF output of the equipment under test was directly connected to the input of the Spectrum Analyzer through a 40 dB passive attenuator. The spectrum analyzer resolution and video bandwidths were set to 300 Hz and 3000 Hz respectively. The internal correction factors of the spectrum analyzer were employed to correct for any cable or attenuator losses. Results of the test are shown below for all modes of operation. Results are shown below in Figures 7.2.2-1 through 7.2.2-2.

7.2.2 Measurement Results

FCC Part 101.11a(6)

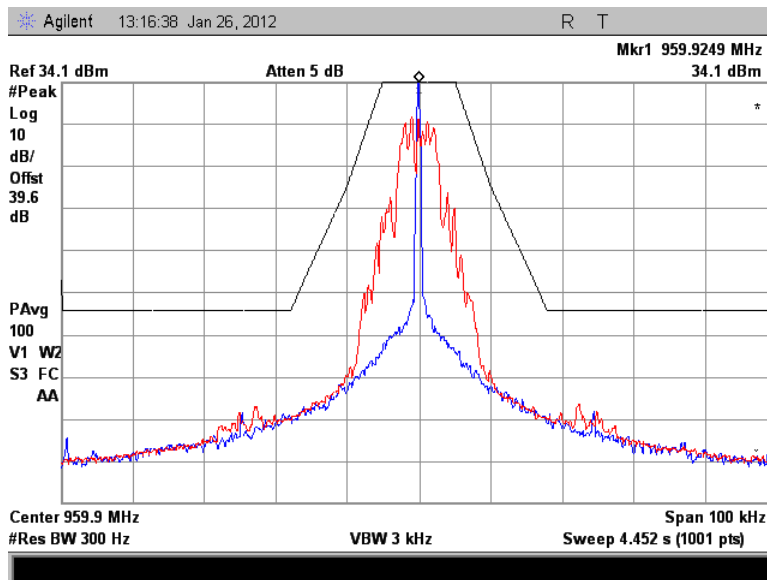

Figure 7.2.2-1: 959.925 MHz – MPass 5k Mode

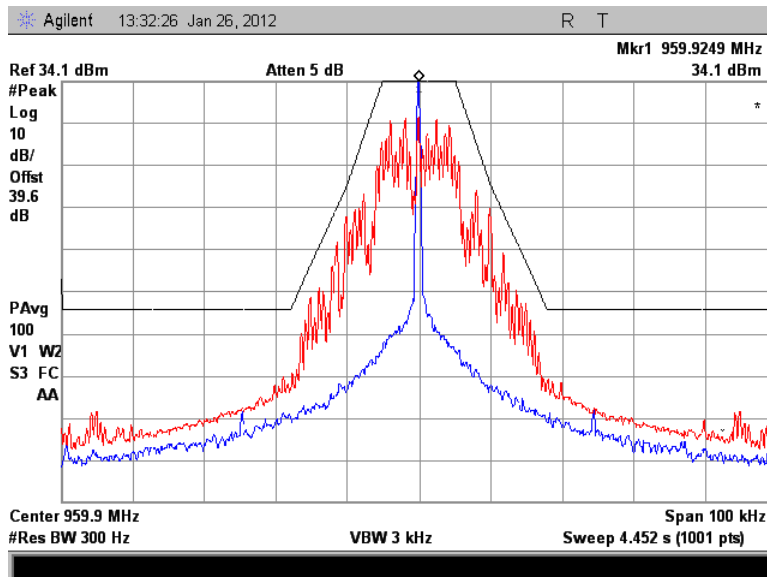

Figure 7.2.2-2: 959.925 MHz – MPass 10k Mode

7.3 Spurious Emissions at Antenna Terminals

7.3.1 Measurement Procedure

The RF output of the equipment under test was directly connected to the input of the Spectrum Analyzer through a 40 dB passive attenuator. The spectrum analyzer resolution bandwidth was set to 100 kHz below 1000 MHz and 1 MHz above 1000 MHz. The internal correction factors of the spectrum analyzer were employed to correct for any cable, attenuator or filter losses. The spectrum was investigated in accordance to CFR 47 Part 2.1057. Results are shown below in Figures 7.3.2-1 through 7.3.2-2.

7.3.2 Measurement Results

Part 101.111 a(6)

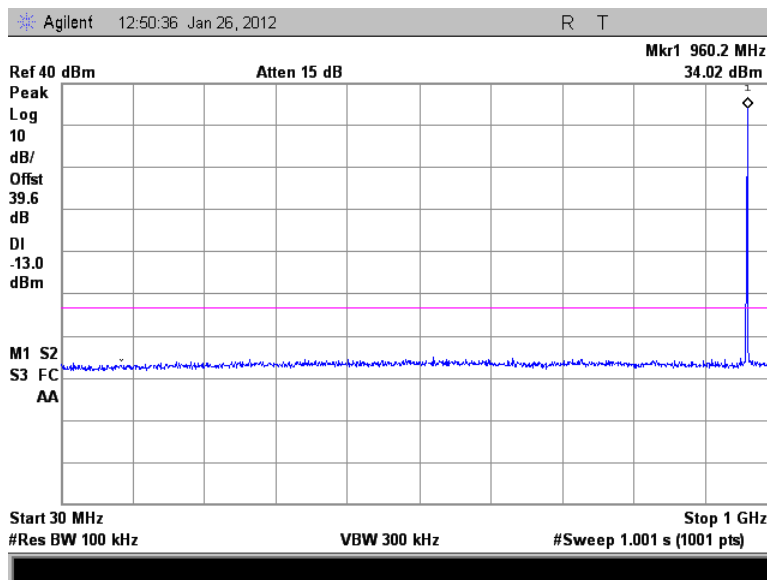

Figure 7.3.2-1: 959.925 MHz – 30MHz to 1GHz

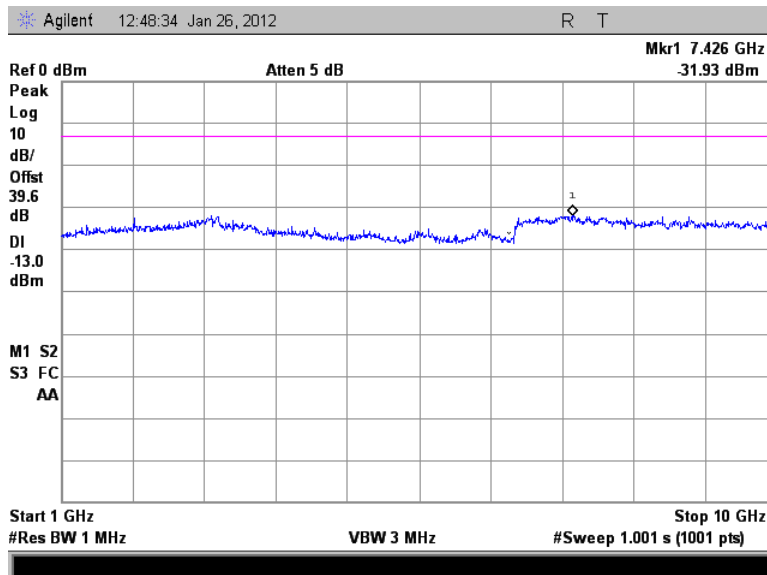

Figure 7.3.2-2: 959.925 MHz – 1GHz to 10GHz

7.4 Field Strength of Spurious Emissions

7.4.1 Measurement Procedure

The equipment under test is placed in the Semi-Anechoic Chamber (described in section 2.3.1) on a wooden table at the turntable center. For each spurious emission, the antenna mast is raised and lowered from one (1) to four (4) meters and the turntable is rotated 360° and the maximum reading on the spectrum analyzer is recorded. This was repeated for both horizontal and vertical polarizations of the receive antenna.

The equipment under test is then replaced with a substitution antenna fed by a signal generator. The signal generator's frequency is set to that of the spurious emission recorded from the equipment under test. The antenna mast is raised and lowered from one (1) to four (4) meters to obtain a maximum reading on the spectrum analyzer. The output of the signal generator is then adjusted until the reading on the spectrum analyzer matches that obtained from the equipment under test. The signal generator level is recorded. The power in dBm of each spurious emission is calculated by correcting the signal generator level for the cable loss and gain of the substitution antenna referenced to a dipole. The spectrum was investigated in accordance to CFR 47 Part 2.1057.

The magnitude of all spurious emissions not reported were attenuated below the noise floor of the measurement system and therefore not specified in this report. Results are shown below in Table 7.4.2-1.

7.4.2 Measurement Results

Part 101.111 a(6)

Table 7.4.2-1: Field Strength of Spurious Emissions – 959.925 MHz

Frequency (MHz)	Spectrum Analyzer Level (dBm)	Antenna Polarity (H/V)	Spurious ERP (dBm)	Limit (dBm)	Margin (dB)
1919.85	-47.80	H	-43.55	-13.00	30.55
2879.775	-24.85	H	-19.80	-13.00	6.80
3839.7	-34.85	H	-24.24	-13.00	11.24
4799.625	-43.00	H	-28.46	-13.00	15.46
5759.55	-44.60	H	-27.28	-13.00	14.28
6719.475	-50.55	H	-29.61	-13.00	16.61
7679.4	-41.70	H	-18.72	-13.00	5.72
1919.85	-47.15	V	-42.95	-13.00	29.95
2879.775	-23.65	V	-17.20	-13.00	4.20
3839.7	-44.00	V	-33.34	-13.00	20.34
4799.625	-44.70	V	-31.01	-13.00	18.01
5759.55	-50.90	V	-35.93	-13.00	22.93
6719.475	-53.45	V	-36.86	-13.00	23.86
7679.4	-45.80	V	-24.77	-13.00	11.77

NOTE: All frequencies not listed were below the noise floor of the spectrum analyzer.

7.5 Frequency Stability

7.5.1 Measurement Procedure

The equipment under test is placed inside an environmental chamber. The RF output is directly coupled to the input of the measurement equipment and a power supply is attached to the primary supply voltage.

Frequency measurements were made at the extremes of the of temperature range -30°C to $+50^{\circ}\text{C}$ and at intervals of 10°C at normal supply voltage. A period of time sufficient to stabilize all components of the equipment was allowed at each frequency measurement. At a temperature 20°C the supply voltage was varied from 85% to 115% from the normal. The maximum variation of frequency was recorded.

Results of the test are shown below in Figure 7.5.2-1.

7.5.2 Measurement Results

Part 101.107

Frequency Stability

Frequency (MHz): 959.925
 Deviation Limit (PPM): 1ppm

Temperature C	Frequency MHz	Frequency Error (PPM)	Voltage (%)	Voltage (VDC)
-30 C	959.925031	0.032	100%	13.60
-20 C	959.924941	-0.061	100%	13.60
-10 C	959.924921	-0.082	100%	13.60
0 C	959.924728	-0.283	100%	13.60
10 C	959.924711	-0.301	100%	13.60
20 C	959.925012	0.013	100%	13.60
30 C	959.925008	0.008	100%	13.60
40 C	959.924845	-0.161	100%	13.60
50 C	959.924861	-0.145	100%	13.60
20 C	959.925013	0.014	85%	11.56
20 C	959.925001	0.001	115%	15.64

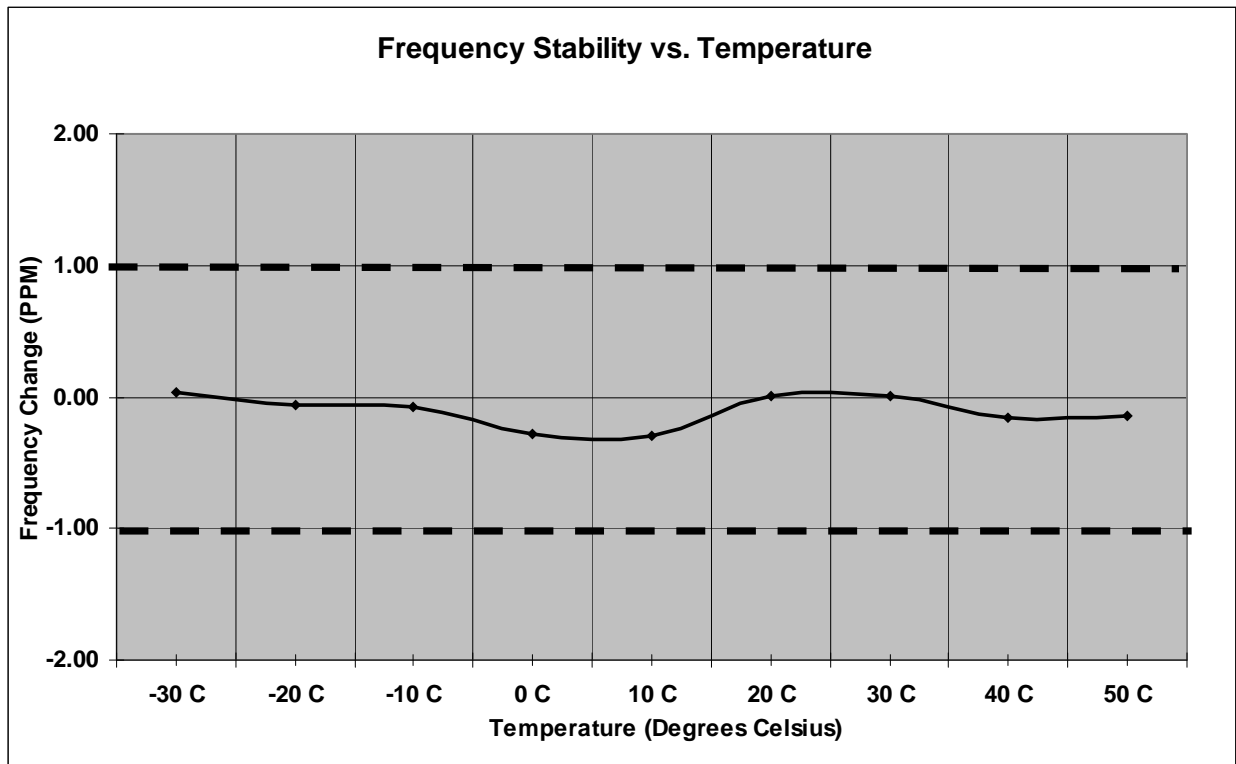

Figure 7.5.2-1: Frequency Stability – 959.925 MHz

8.0 CONCLUSION

In the opinion of ACS, Inc. the model M4601, manufactured by Sensus Metering Systems, Inc., meets all the requirements of FCC Part 101 were applicable.

End Report