

## **Certification Test Report**

**FCC ID: SDBM400BV03**

**FCC Rule Part: CFR 47 Part 101 Subpart C**

**ACS Report Number: 13-2044.W03.1A**

**Applicant: Sensus Metering Systems, Inc.  
Model: M400B-03**

**Test Begin Date: April 5, 2013**

**Test End Date: April 19, 2013**

**Report Issue Date: May 7, 2013**



For The Scope of Accreditation Under Certificate Number AT-1533



For The Scope of Accreditation Under Lab Code 200612-0

This report must not be used by the client to claim product certification, approval, or endorsement by ACCLASS, NVLAP, ANSI, or any agency of the Federal Government.

**Project Manager:**



**Thierry Jean-Charles  
EMC Engineer  
Advanced Compliance Solutions, Inc.**

**Reviewed by:**



**Kirby Munroe  
Director, Wireless Certifications  
Advanced Compliance Solutions, Inc.**

This test report shall not be reproduced except in full. This report may be reproduced in part with prior written consent of ACS, Inc. The results contained in this report are representative of the sample(s) submitted for evaluation.

**This report contains 24 pages**

# Table of Content

---

<b>1.0 GENERAL</b> .....	<b>3</b>
<b>1.1 PURPOSE</b> .....	<b>3</b>
<b>1.2 PRODUCT DESCRIPTION</b> .....	<b>3</b>
<b>1.3 TEST METHODOLOGY</b> .....	<b>3</b>
<b>1.4 EMISSION DESIGNATORS</b> .....	<b>4</b>
<b>2.0 TEST FACILITIES</b> .....	<b>5</b>
<b>2.1 LOCATION</b> .....	<b>5</b>
<b>2.2 LABORATORY ACCREDITATIONS/RECOGNITIONS/CERTIFICATIONS</b> .....	<b>5</b>
<b>2.3 RADIATED &amp; CONDUCTED EMISSIONS TEST SITE DESCRIPTION</b> .....	<b>6</b>
<b>3.0 APPLICABLE STANDARD REFERENCES</b> .....	<b>8</b>
<b>4.0 LIST OF TEST EQUIPMENT</b> .....	<b>9</b>
<b>5.0 SUPPORT EQUIPMENT</b> .....	<b>10</b>
<b>6.0 EQUIPMENT UNDER TEST SETUP AND BLOCK DIAGRAM</b> .....	<b>10</b>
<b>7.0 SUMMARY OF TESTS</b> .....	<b>11</b>
<b>7.1 RF POWER OUTPUT</b> .....	<b>11</b>
<b>7.2 OCCUPIED BANDWIDTH (EMISSION LIMITS)</b> .....	<b>13</b>
<b>7.3 SPURIOUS EMISSIONS AT ANTENNA TERMINALS</b> .....	<b>18</b>
<b>7.4 FIELD STRENGTH OF SPURIOUS EMISSIONS</b> .....	<b>20</b>
<b>7.5 FREQUENCY STABILITY</b> .....	<b>22</b>
<b>8.0 CONCLUSION</b> .....	<b>24</b>

## **1.0 GENERAL**

### **1.1 Purpose**

The purpose of this report is to demonstrate compliance with the specific test requirements of Part 2 Subpart J, Part 101 Subpart C of the FCC's Code of Federal Regulations.

### **1.2 Product Description**

The Sensus FlexNet M400B-03 consists of the M400XCVR-00 transceiver, PA module and a high isolation duplexer in a cabinet configuration. The output power of the M400B-03 ranges from 1W to 8W.

Manufacturer Information:  
Sensus Metering Systems, Inc.  
639 Davis Drive  
Morrisville, NC 27560

Test Sample Serial Numbers: C56 (Cabinet), 180503130500008 (M400XCVR-00), SMS5396335800005 (PA), 0000104 (Duplexer).

Test Sample Hardware Revisions:  
RF: R3.1, BOMr03 3/8/13  
Digital: R3.1, BOMr03 1/15/13

Test Sample Software Revisions:  
RF: 2.B  
TIP: 2.A  
DSP: 1.8  
FPGA: 5.9

Test Sample Condition: The unit was in good operating conditions with no physical damages.

### **1.3 Test Methodology**

#### **1.3.1 Configurations and Justification**

The EUT was tested for radiated emissions and RF conducted measurements at the antenna port. The evaluation was performed for both low and high power modes of operation. The EUT provides multiple data rates, where applicable data is provided for the configuration corresponding to the worst case.

The radiated emissions measurements were performed up to the 10th harmonic with a 50 ohm termination at the RF output. The unit was evaluated in the orientation of typical installation.

The RF conducted measurements were collected at the RF output via suitable attenuation.

The EUT was also evaluated for unintentional emissions. The results are provided in a separately in a verification test report.

**1.3.2 In-Band Testing Methodology**

The following is a list of the frequency bands of operation sorted based on the FCC rule parts in which the band is associated.

CFR Title 47 Rule Part	Frequency Band of Operation (MHz)
101	959.85-960.0

**1.4 Emission Designators**

The M400B-03 transmitter produces four distinct modulation formats. The emissions designators for the modulation types used by the M400B-03 transmitter are as follows:

EMISSIONS DESIGNATORS:

- mPass mode (5 kbps): 5K90F1D
- mPass mode (10 kbps): 11K8F1D
- m4Pass mode (10 kbps): 8K75F1D
- m4Pass mode (20 kbps): 17K5F1D

## 2.0 TEST FACILITIES

### 2.1 Location

The radiated and conducted emissions test sites are located at the following address:

#### Site 1

Advanced Compliance Solutions, Inc.  
3998 FAU Blvd, Suite 310  
Boca Raton, Florida 33431  
Phone: (561) 961-5585  
Fax: (561) 961-5587  
[www.acstestlab.com](http://www.acstestlab.com)

#### Site 2

Advanced Compliance Solutions, Inc.  
5015 B.U. Bowman Drive  
Buford GA 30518  
Phone: (770) 831-8048  
Fax: (770) 831-8598  
[www.acstestlab.com](http://www.acstestlab.com)

FCC Test Firm Registration #: 587595  
Industry Canada Lab Code: 4175C

### 2.2 Laboratory Accreditations/Recognitions/Certifications

#### Site 1

ACS, Boca Raton, Florida, is accredited to ISO/IEC 17025 by ANSI-ASQ National Accreditation Board under their ACLASS program and has been issued certificate number AT-1533 in recognition of this accreditation.

#### Site 2

ACS, Buford, GA is accredited to ISO/IEC 17025 by the National Institute of Standards and Technology under their National Voluntary Laboratory Accreditation Program (NVLAP).

Unless otherwise specified, all test methods described within this report are covered under the respective test site ISO/IEC 17025 scope of accreditation.

**2.3 Radiated & Conducted Emissions Test Site Description**

**2.3.1 Semi-Anechoic Chamber Test Site**

The EMC radiated test facility consists of an RF-shielded enclosure. The interior dimensions of the indoor semi-anechoic chamber are approximately 48 feet (14.6 m) long by 36 feet (10.8 m) wide by 24 feet (7.3 m) high and consist of rigid, 1/8 inch (0.32 cm) steel-clad, wood core modular panels with steel framing. In the shielded enclosure, the faces of the panels are galvanized and the chamber is self-supporting. 8-foot RF absorbing cones are installed on 4 walls and the ceiling. The steel-clad ground plane is covered with vinyl floor.

The turntable is driven by pneumatic motor, which is capable of supporting a 2000 lb. load. The turntable is flushed with the chamber floor which it is connected to, around its circumference, with metallic loaded springs. An EMCO Model 1051 Multi-device Controller controls the turntable position.

A pneumatic motor is used to control antenna polarizations and height relative to the ground. The height information is displayed on the control unit EMCO Model 1050.

The control room is an RF shielded enclosure attached to the semi-anechoic chamber with two bulkhead panels for connecting RF, and control cables. The dimension of the room is 7.3 m x 4.9 m x 3 m high and the entrance doors of both control and conducted rooms are 3 feet (0.91 m) by 7 feet (2.13 m).

A diagram of the Semi-Anechoic Chamber Test Site is shown in Figure 2.3.1-1 below:

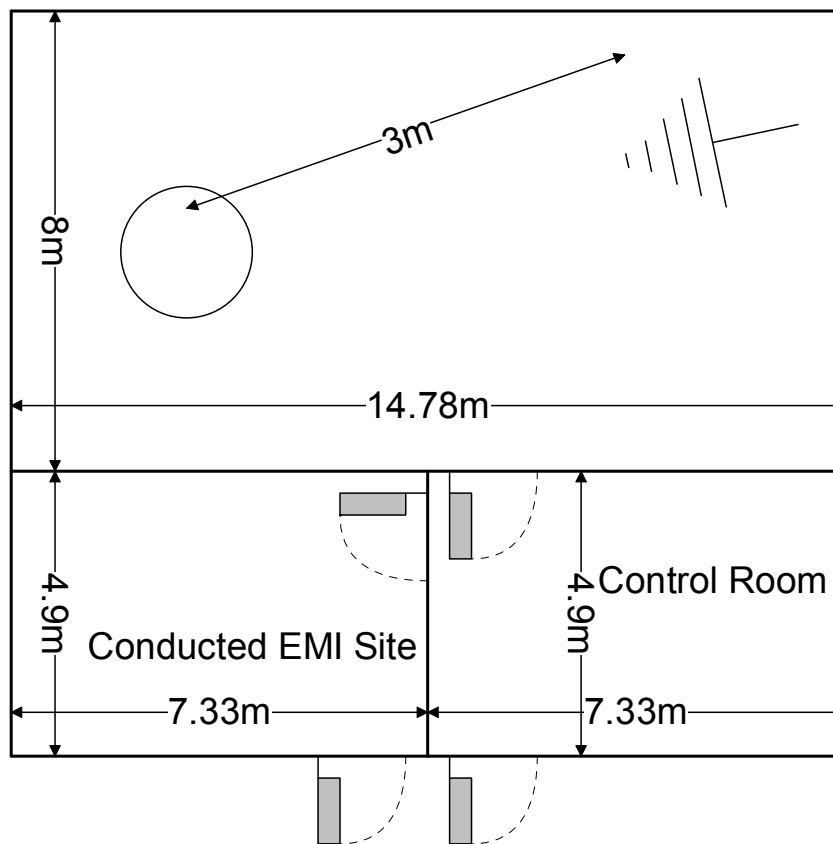

**Figure 2.3.1-1: Semi-Anechoic Chamber Test Site**

### 2.3.2 Conducted Emissions Test Site Description

The dimensions of the shielded conducted room are 7.3 x 4.9 x 3 m<sup>3</sup>. As per ANSI C63.4 2003 requirements, the data were taken using two LISNs; a Solar Model 8028-50 50 Ω/50 μH and an EMCO Model 3825, which are installed as shown in Photograph 3. For 220 V, 50 Hz, a Polarad LISN (S/N 879341/048) is used in conjunction with a 1 kVA, 50 Hz/220 V EDGAR variable frequency generator, Model 1001B, to filter conducted noise from the generator.

A diagram of the room is shown below in figure 2.3.2-1:

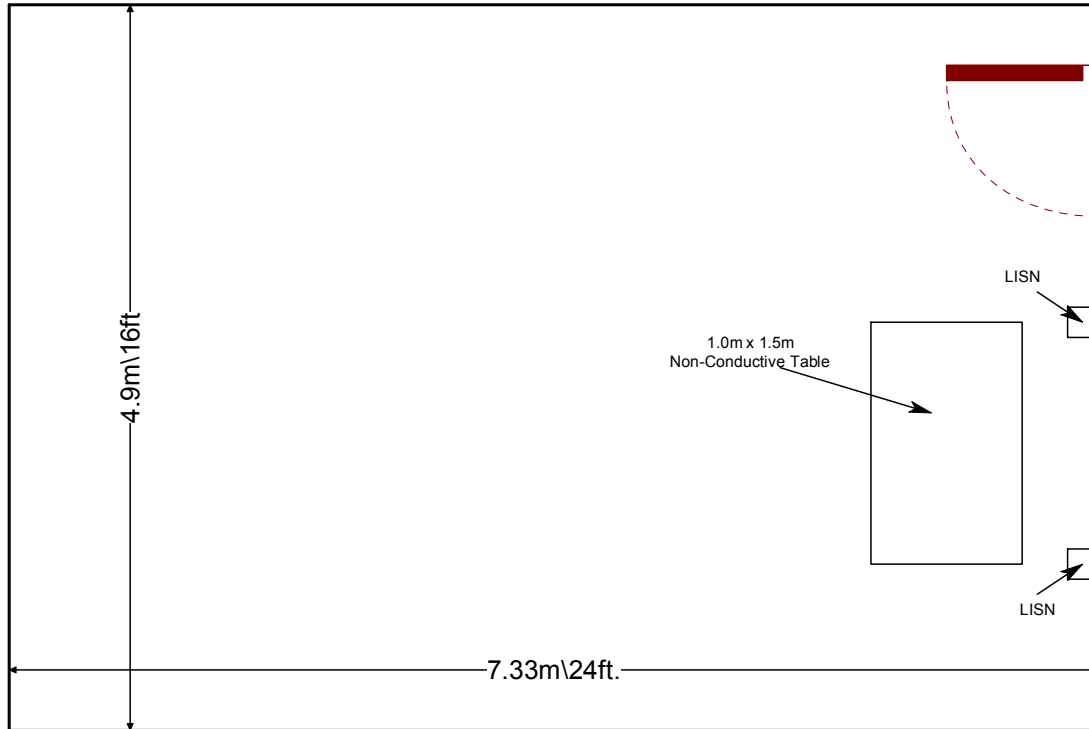

Figure 2.3.2-1: AC Mains Conducted EMI Site

### **3.0 APPLICABLE STANDARD REFERENCES**

The following standards were used:

- 1 - ANSI C63.4-2003: Method of Measurements of Radio-Noise Emissions from Low-Voltage Electrical and Electronic Equipment in the 9 kHz to 40GHz - 2003
- 2 - US Code of Federal Regulations (CFR): Title 47, Part 2, Subpart J: Equipment Authorization Procedures - 2013
- 3 - US Code of Federal Regulations (CFR): Title 47, Part 101, Subpart C: Fixed Microwave Services - 2013
- 4 – TIA-603-D: Land Mobile FM or PM - Communications Equipment - Measurement and Performance Standards – 2010



#### 4.0 LIST OF TEST EQUIPMENT

The calibration interval of test equipment is annually or the manufacturer's recommendations. Where the calibration interval deviates from the annual cycle based on the instrument manufacturer's recommendations, it shall be stated below.

**Table 4-1: Test Equipment**

AssetID	Manufacturer	Model #	Equipment Type	Serial #	Last Calibration Date	Calibration Due Date
140	Thermotron	SM-16C	Environmental Chamber	19639	8/2/2012	8/2/2013
283	Rohde & Schwarz	FSP40	Spectrum Analyzers	1000033	8/1/2012	8/1/2013
308	General Radio USA	PLZ150W	Transformer	N/A	NCR	NCR
339	Aeroflex/Weinschel	AS-18	Attenuators	7142	6/4/2012	6/4/2013
371	Fluke	Fluke 115	Meters	93872717	8/1/2012	8/1/2014
523	Agilent	E7405	Spectrum Analyzers	MY45103293	1/8/2013	1/8/2015
524	Chase	CBL6111	Antennas	1138	1/7/2013	1/7/2015
562	United Microwave Products, Inc.	AA-190-00.48.0	Cables	562	7/31/2012	7/31/2013
1161	Electro Metrics	RGA-180	Antennas	2121	4/11/2011	7/11/2013
2007	EMCO	3115	Antennas	2419	1/18/2012	1/18/2014
2011	Hewlett-Packard	HP 8447D	Amplifiers	2443A03952	12/31/2012	12/31/2013
2037	ACS Boca	Chamber EMI Cable Set	Cable Set	2037	1/1/2013	1/1/2014
2071	Trilithic, Inc.	4HC1400-1-KK	Filter	9643263	12/31/2012	12/31/2013
2075	Hewlett Packard	8495B	Attenuators	2626A11012	12/31/2012	12/31/2013
2078	ACS Boca	Substitution Cable Set	Cable Set	2078	1/1/2013	1/1/2014
2082	Teledyne Storm Products	90-010-048	Cables	2082	5/31/2012	5/31/2013
2089	Agilent Technologies, Inc.	83017A	Amplifiers	3123A00214	12/20/2012	12/20/2013
2091	Agilent Technologies, Inc.	8573A	Spectrum Analyzers	2407A03233	12/12/2011	12/12/2013
RE563	Hewlett Packard	8673D	Signal Generators	3034A01078	3/21/2013	3/21/2015
RE587	Fairview Microwave Inc.	SA3N511-15	Attenuators	RE587	4/18/2012	4/18/2013
RE587	Fairview Microwave Inc.	SA3N511-15	Attenuators	RE587	4/3/2013	4/3/2014

**NCR=No Calibration Required**

5.0 SUPPORT EQUIPMENT

Table 5-1: EUT and Support Equipment

Item #	Type Device	Manufacturer	Model/Part #	Serial #
1	EUT	Sensus metering Systems	M400B-03	C56
2	50 Ohm Termination	Narda	376BNF	9401

Note: A 50 Ohm load was used for the radiated spurious emissions evaluation.

Table 5-2: Cable Description

Cable #	Cable Type	Length	Shield	Termination
A	Power Cord	0.6 m	No	EUT to Extension Cord
B	Extension Power Cord	1.65m	No	EUT Power Cord to AC Mains

6.0 EQUIPMENT UNDER TEST SETUP AND BLOCK DIAGRAM

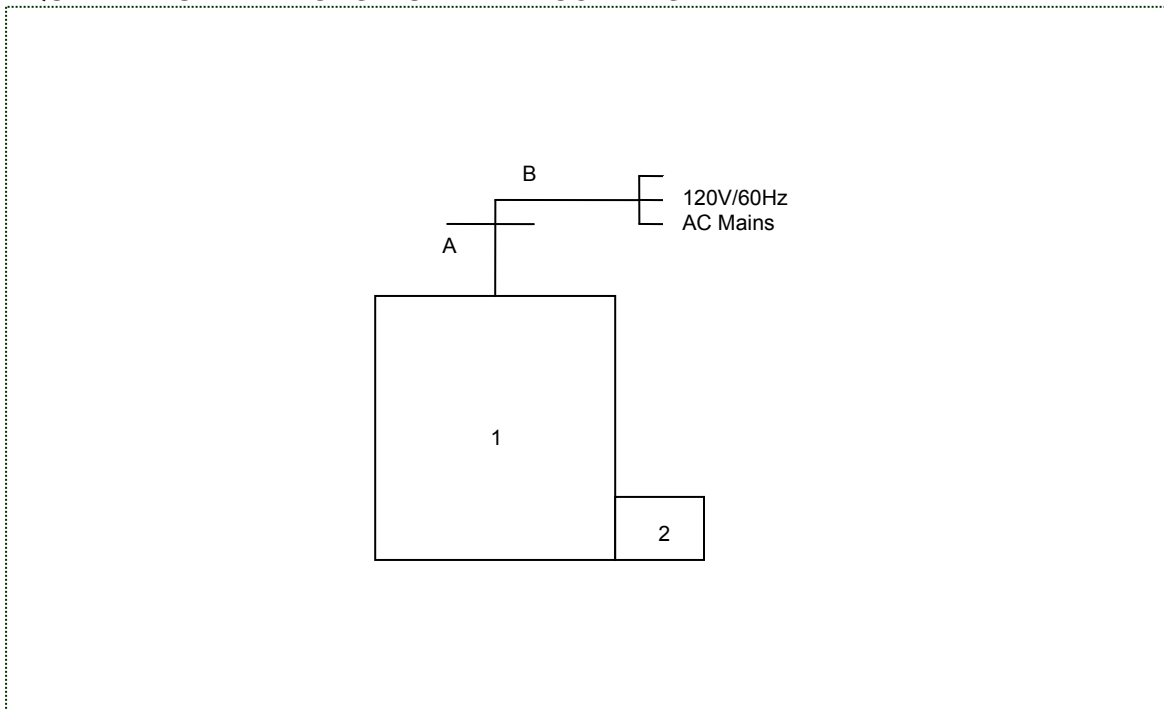

Figure 6-1: EUT Test Setup

**7.0 SUMMARY OF TESTS**

Along with the tabular data shown below, plots were taken of all signals deemed important enough to document.

**Table 7-1: Test Results Summary**

Test Parameter	Test Site	Test Summary
RF Power Output	1	Pass
Occupied Bandwidth (Emissions Limits)	1	Pass
Spurious Emissions at Antenna Terminals	1	Pass
Field Strength of Spurious Emissions	1	Pass
Frequency Stability	2	Pass

**7.1 RF Power Output**

**7.1.1 Measurement Procedure**

The RF output of the equipment under test was directly connected to the input of the Spectrum Analyzer through 35 dB of passive attenuation. The resolution and video bandwidths of the spectrum analyzer were set at sufficient levels, >> signal bandwidth, to produce accurate results. The internal correction factors of the spectrum analyzer were employed to correct for any cable or attenuator losses. Results are shown below.

**7.1.2 Measurement Results**

**Table 7.1.2-1: Peak Output Power – Low Power**

Frequency (MHz)	FCC Rule Part	Output Power (Low Power) (dBm)	Output Power (High Power) (dBm)
959.925	101	29.77	38.64

**Part 101.113(a)**

**Low Power**

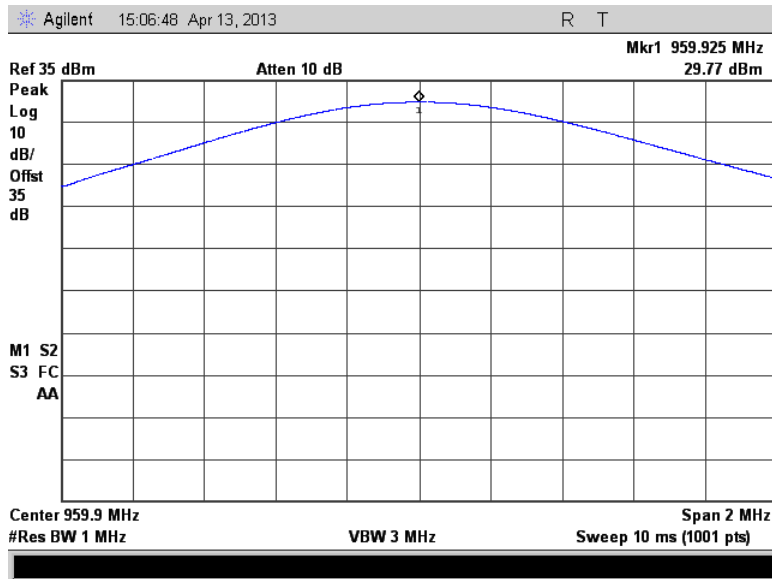

**Figure 7.1.2-1: Peak Output Power – 959.925 MHz**

**High Power**

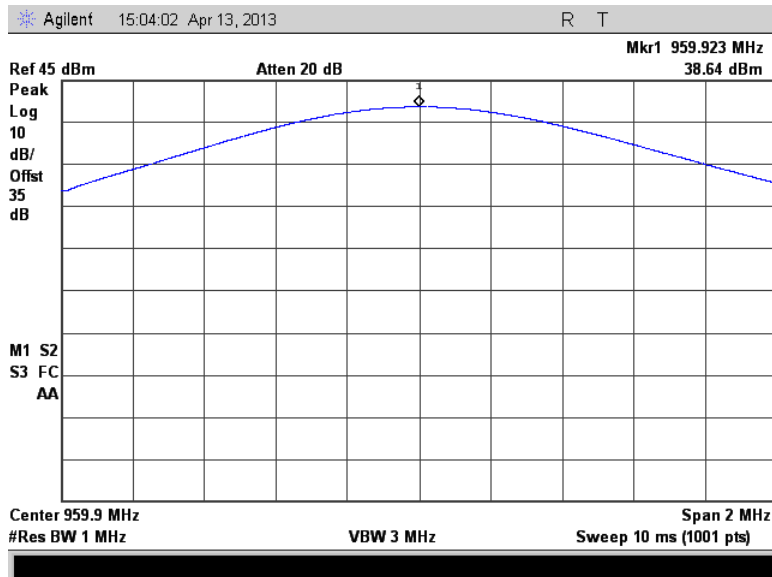

**Figure 7.1.2-2: Peak Output Power – 959.925 MHz**

7.2 Occupied Bandwidth (Emission Limits)

7.2.1 Measurement Procedure

The RF output of the equipment under test was directly connected to the input of the Spectrum Analyzer through 35 dB of passive attenuation. The spectrum analyzer resolution and video bandwidths were set to 300 Hz and 3000 Hz respectively. The internal correction factors of the spectrum analyzer were employed to correct for any cable or attenuator losses. Results of the test are shown below for all modes of operation.

7.2.2 Measurement Results

Part 101.111 a(6)

Low Power

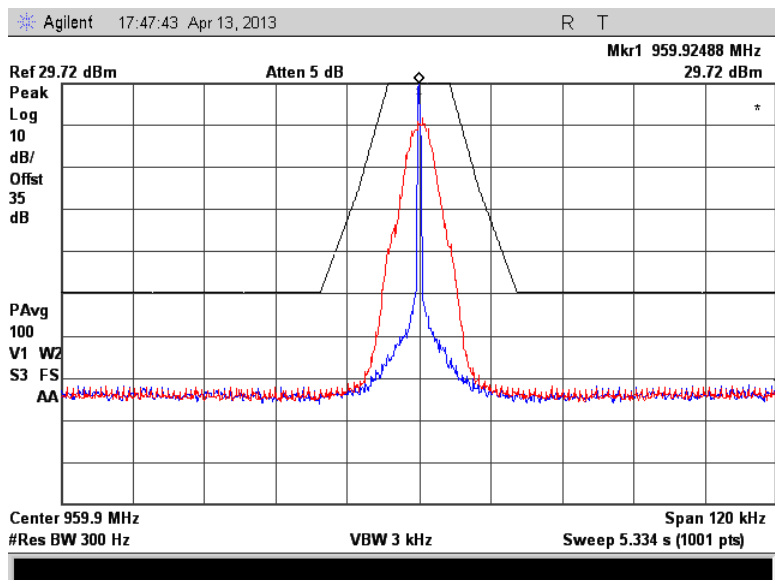

Figure 7.2.2-1: 959.925 MHz – m4Pass 10k

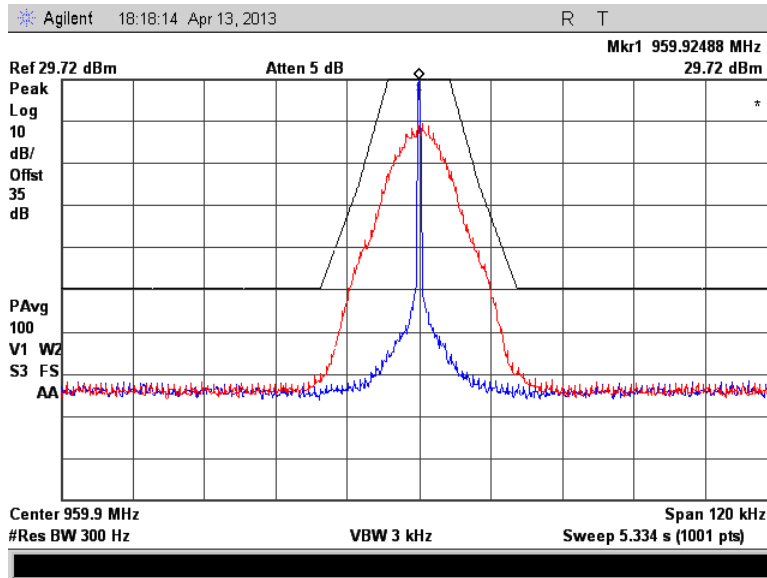

Figure 7.2.2-2: 959.925 MHz – m4Pass 20k

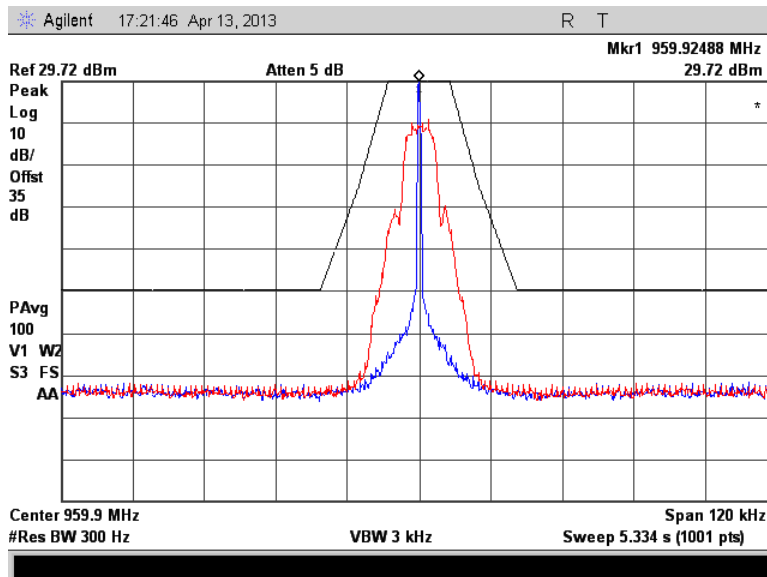

Figure 7.2.2-3: 959.925 MHz – mPass 5k

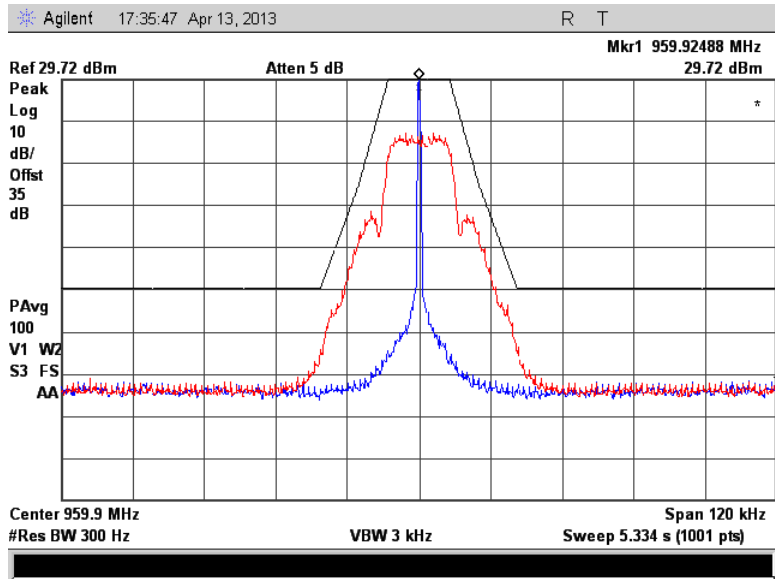

Figure 7.2.2-4: 959.925 MHz – mPass 10k

High Power

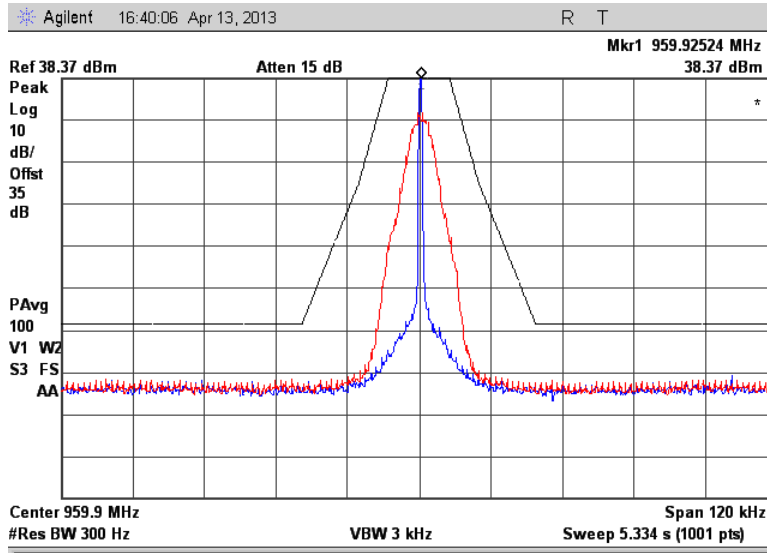

Figure 7.2.2-5: 959.925 MHz – m4Pass 10k

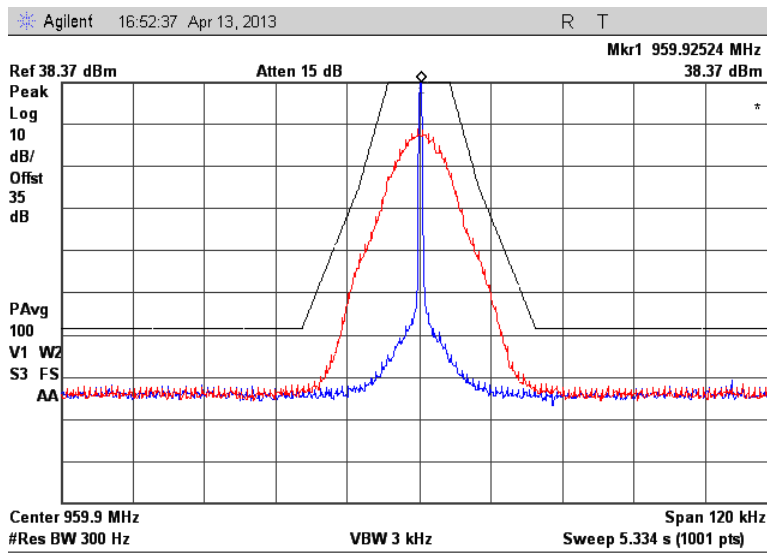

Figure 7.2.2-6: 959.925 MHz – m4Pass 20k



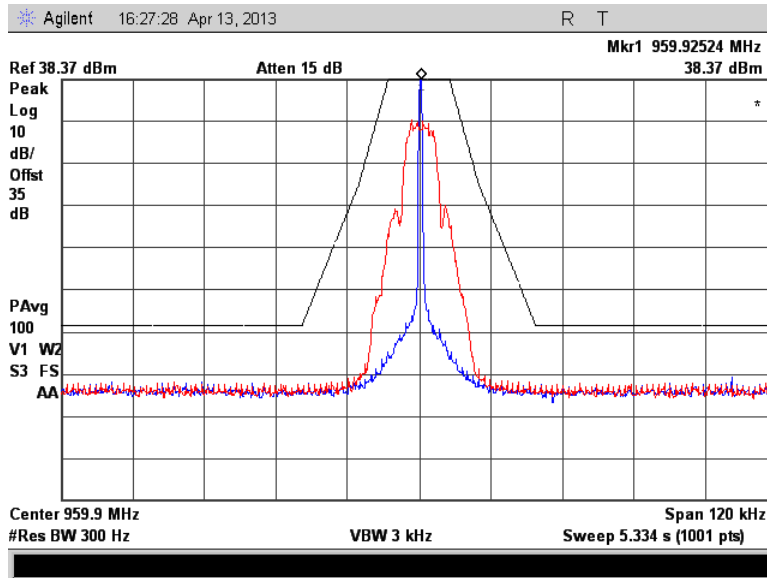

Figure 7.2.2-7: 959.925 MHz – mPass 5k

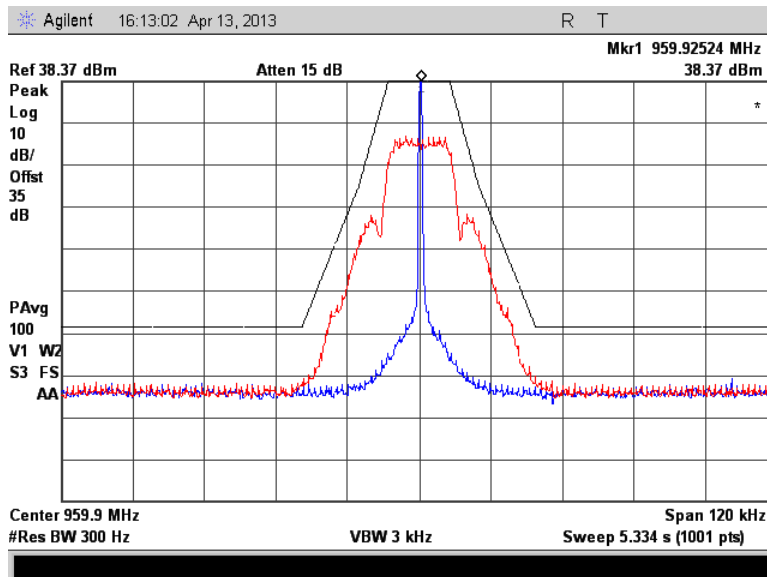

Figure 7.2.2-8: 959.925 MHz – mPass 10k

### 7.3 Spurious Emissions at Antenna Terminals

#### 7.3.1 Measurement Procedure

The RF output of the equipment under test was directly connected to the input of the Spectrum Analyzer through 35 dB of passive attenuation. The spectrum analyzer resolution bandwidth was set to 100 kHz below 1000 MHz and 1 MHz above 1000 MHz. The internal correction factors of the spectrum analyzer were employed to correct for any cable, attenuator or filter losses. The spectrum was investigated in accordance to CFR 47 Part 2.1057. Results are shown below.

#### 7.3.2 Measurement Results

##### Part 101.111 a(6)

##### Low Power

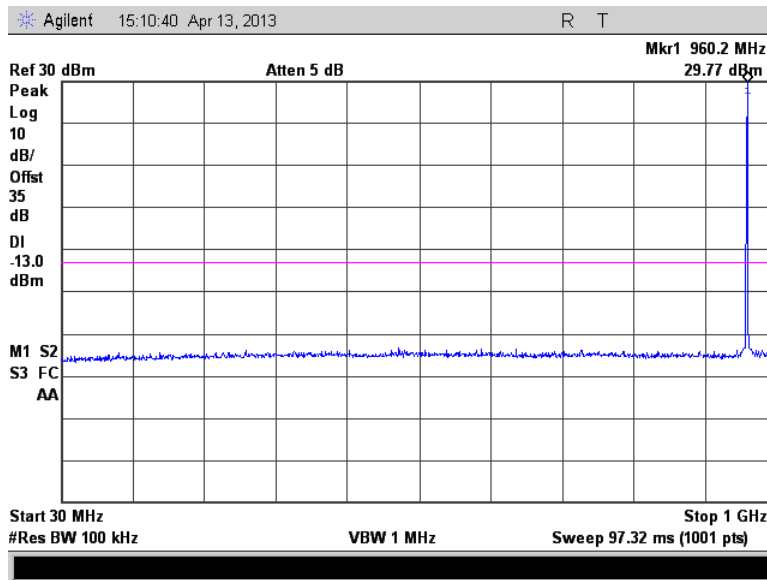

Figure 7.3.2-1: 959.925 MHz – 30MHz to 1GHz

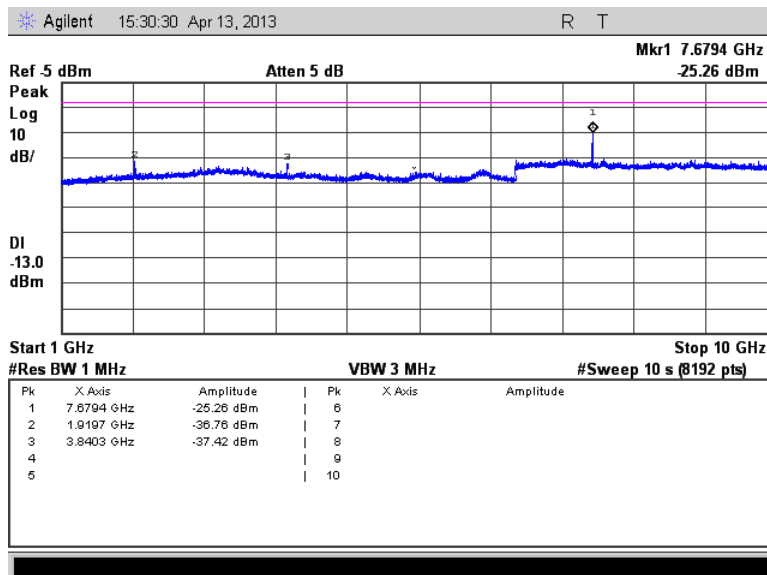
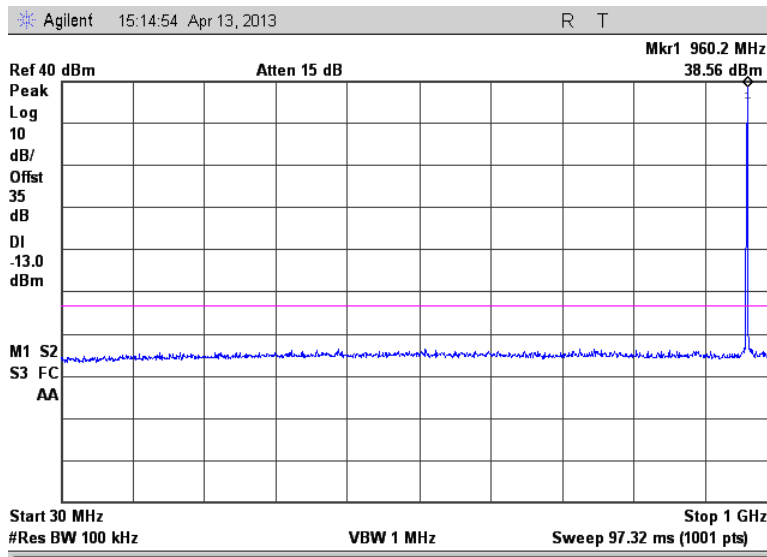
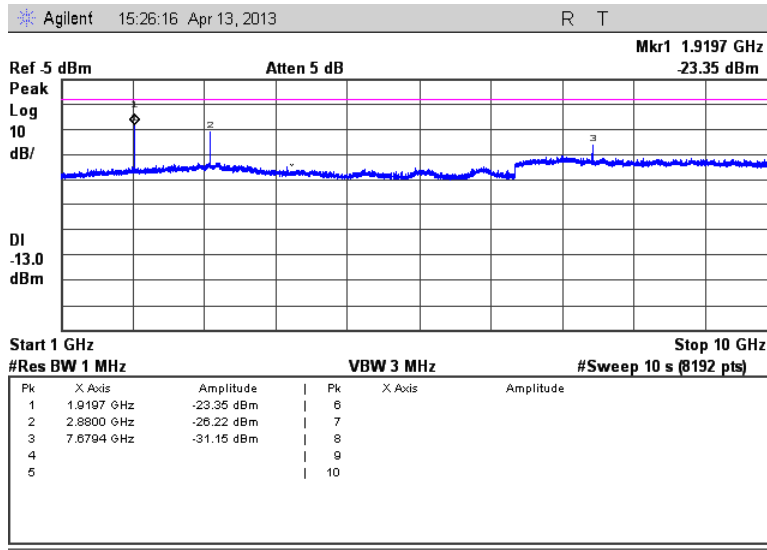

Figure 7.3.2-2: 959.925 MHz – 1GHz to 10GHz

**High Power**



**Figure 7.3.2-3: 959.925 MHz – 30MHz to 1GHz**



**Figure 7.3.2-4: 959.925 MHz – 1GHz to 10GHz**

**7.4 Field Strength of Spurious Emissions**

**7.4.1 Measurement Procedure**

The equipment under test is placed in the Semi-Anechoic Chamber (described in section 2.3.1) on a wooden table at the turntable center. For each spurious emission, the antenna mast is raised and lowered from one (1) to four (4) meters and the turntable is rotated 360° and the maximum reading on the spectrum analyzer is recorded. This was repeated for both horizontal and vertical polarizations of the receive antenna.

The equipment under test is then replaced with a substitution antenna fed by a signal generator. The signal generator’s frequency is set to that of the spurious emission recorded from the equipment under test. The antenna mast is raised and lowered from one (1) to four (4) meters to obtain a maximum reading on the spectrum analyzer. The output of the signal generator is then adjusted until the reading on the spectrum analyzer matches that obtained from the equipment under test. The signal generator level is recorded. The power in dBm of each spurious emission is calculated by correcting the signal generator level for the cable loss and gain of the substitution antenna referenced to a dipole. The spectrum was investigated in accordance to CFR 47 Part 2.1057.

The magnitude of all spurious emissions not reported were attenuated below the noise floor of the measurement system and therefore not specified in this report. Results are shown below.

**7.4.2 Measurement Results**

**Part 101.111 a(6)**

**Low Power**

**Table 7.4.2-1: Field Strength of Spurious Emissions – 959.925 MHz**

Frequency (MHz)	Spectrum Analyzer Level (dBm)	Antenna Polarity (H/V)	Spurious ERP (dBm)	Limit (dBm)	Margin (dB)
1919.85	-44.95	H	-41.95	-13.00	28.95
2879.775	-44.10	H	-37.16	-13.00	24.16
3839.7	-53.05	H	-43.00	-13.00	30.00
4799.625	-60.45	H	-53.84	-13.00	40.84
5759.55	-61.10	H	-56.14	-13.00	43.14
6719.475	-58.35	H	-48.64	-13.00	35.64
7679.4	-57.25	H	-41.03	-13.00	28.03
1919.85	-47.55	V	-44.95	-13.00	31.95
2879.775	-46.50	V	-38.61	-13.00	25.61
3839.7	-56.85	V	-48.00	-13.00	35.00
4799.625	-59.90	V	-55.84	-13.00	42.84
7679.4	-58.00	V	-45.28	-13.00	32.28

NOTE: All frequencies not listed were below the noise floor of the spectrum analyzer.

**High Power**

**Table 7.4.2-2: Field Strength of Spurious Emissions – 959.925 MHz**

Frequency (MHz)	Spectrum Analyzer Level (dBm)	Antenna Polarity (H/V)	Spurious ERP (dBm)	Limit (dBm)	Margin (dB)
1919.85	-53.25	H	-52.80	-13.00	39.80
2879.775	-43.05	H	-36.01	-13.00	23.01
3839.7	-58.60	H	-52.20	-13.00	39.20
4799.625	-60.35	H	-53.74	-13.00	40.74
6719.475	-57.70	H	-45.59	-13.00	32.59
1919.85	-54.30	V	-54.35	-13.00	41.35
2879.775	-43.90	V	-36.21	-13.00	23.21
3839.7	-59.55	V	-55.65	-13.00	42.65
4799.625	-60.55	V	-56.04	-13.00	43.04

NOTE: All frequencies not listed were below the noise floor of the spectrum analyzer.

## **7.5 Frequency Stability**

### **7.5.1 Measurement Procedure**

The equipment under test is placed inside an environmental chamber. The RF output is directly coupled to the input of the measurement equipment and a power supply is attached to the primary supply voltage.

Frequency measurements were made at the extremes of the of temperature range  $-30^{\circ}\text{C}$  to  $+50^{\circ}\text{C}$  and at intervals of  $10^{\circ}\text{C}$  at normal supply voltage. A period of time sufficient to stabilize all components of the equipment was allowed at each frequency measurement. At a temperature  $20^{\circ}\text{C}$  the measurements were performed at 85% and 115% of the EUT nominal voltage. The maximum variation of frequency was recorded.

Since the EUT falls under multiple rule parts, the most stringent ppm limit from the different rule parts was applied for the measurements. The results of the tests are shown below.

7.5.2 Measurement Results

Part 101.107

## Frequency Stability

Frequency (MHz): 959.925

Deviation Limit (PPM): 1.5 ppm

Temperature C	Frequency MHz	Frequency Error (PPM)	Voltage (%)	Voltage (VAC)
-30 C	959.925005	0.005	100%	120.00
-20 C	959.925252	0.263	100%	120.00
-10 C	959.925225	0.234	100%	120.00
0 C	959.925086	0.090	100%	120.00
10 C	959.925178	0.185	100%	120.00
20 C	959.925094	0.098	100%	120.00
30 C	959.925209	0.218	100%	120.00
40 C	959.925211	0.220	100%	120.00
50 C	959.924956	-0.046	100%	120.00
20 C	959.925120	0.125	85%	102.00
20 C	959.925128	0.133	115%	138.00

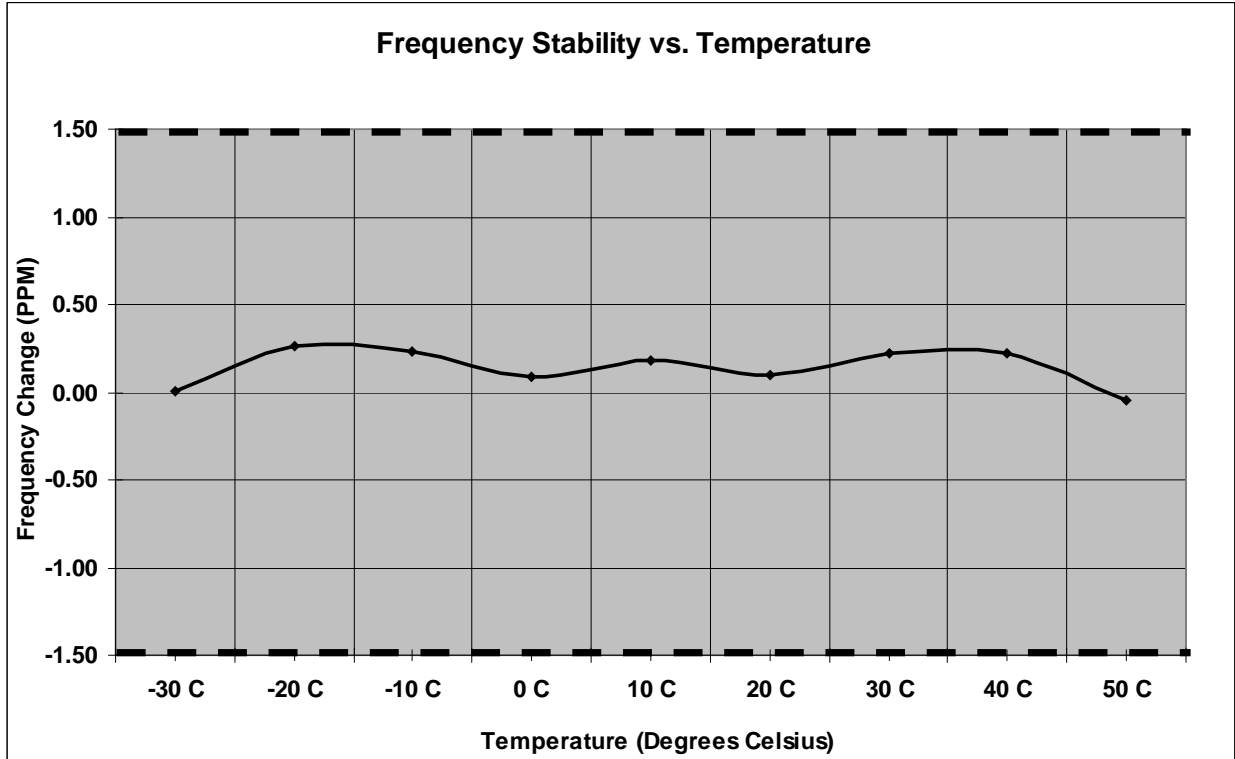

Figure 7.5.2-1: Frequency Stability – 959.925 MHz

**8.0 CONCLUSION**

In the opinion of ACS, Inc. the model M400B-03, manufactured by Sensus Metering Systems, Inc., meets all the requirements of FCC Part 101 where applicable.

End Report